

लाइव वर्किंग — पारेषण और वितरण  
लाइन कंडक्टर्स और पृथ्वी के तार की  
स्थापना के लिए दिशानिर्देश — स्ट्रिंगिंग  
उपकरण और सहायक सामान

(पहला पुनरीक्षण)

**Live Working — Guidelines for  
the Installation of Transmission  
and Distribution Line Conductors  
and Earth Wires — Stringing  
Equipment and Accessory Items**

( First Revision )

ICS 13.260; 29.240.20; 29.260.01

© BIS 2023

© IEC 2017



भारतीय मानक ब्यूरो

BUREAU OF INDIAN STANDARDS

मानक भवन, 9 बहादुर शाह ज़फर मार्ग, नई दिल्ली - 110002

MANAK BHAVAN, 9 BAHADUR SHAH ZAFAR MARG

NEW DELHI - 110002

[www.bis.gov.in](http://www.bis.gov.in) [www.standardsbis.in](http://www.standardsbis.in)

## NATIONAL FOREWORD

This Indian Standard (First Revision) which is identical with IEC TR 61328 : 2017 'Live working — Guidelines for the installation of transmission and distribution line conductors and earth wires — Stringing equipment and accessory items' issued by the International Electrotechnical Commission (IEC) was adopted by the Bureau of Indian Standards on the recommendation of the Tools And Equipment for Live Working Sectional Committee and approval of the Electrotechnical Division Council.

This standard was originally published in 2019. The first revision of this standard has been undertaken to align it with the latest version of IEC TR 61328 to make pace with the latest developments that have taken place at International level.

The text of the IEC standard has been approved as suitable for publication as an Indian Standard without deviations. Certain conventions are, however, not identical to those used in Indian Standards. Attention is particularly drawn to the following:

- a) Wherever the words 'International Standard' appear referring to this standard, they should be read as 'Indian Standard'; and
- b) Comma (,) has been used as a decimal marker, while in Indian Standards the current practice is to use a point (.) as the decimal marker.

In this adopted standard, reference appears to certain International Standards for which Indian Standards also exist. The corresponding Indian Standards, which are to be substituted in their respective places, are listed below along with their degree of equivalence for the editions indicated:

<i>International Standard</i>	<i>Corresponding Indian Standard</i>	<i>Degree of Equivalence</i>
IEC 60743 Live working — Terminology for tools, devices and equipment	IS 15416 : 2017/IEC 60743 : 2013 Live working — Terminology for tools, devices and equipment ( <i>first revision</i> )	Identical

The Committee has reviewed the provisions of the following International Standards referred to in this adopted standard and has decided that they are acceptable for use in conjunction with this standard:

<i>International Standard</i>	<i>Title</i>
IEC 60050-466	International electrotechnical vocabulary — Chapter 466: Overhead lines
IEC 60050-651	International electrotechnical vocabulary — Part 651: Live working

Only the English language text has been retained while adopting it in this Indian Standard, and as such, the page numbers given here are not the same as in the IEC Publication.

For the purpose of deciding whether a particular requirement of this standard is complied with the final value, observed or calculated expressing the result of a test or analysis shall be rounded off in accordance with IS 2 : 2022 'Rules for rounding of numerical values (*second revision*)'. The number of significant places retained in the rounded off value should be the same as that of the specified value in this standard.

## CONTENTS

INTRODUCTION.....	v
1 Scope.....	1
2 Normative references .....	1
3 Terms and definitions .....	1
4 Understanding the hazard – Basic theory .....	11
4.1 General.....	11
4.2 Electric field induction from nearby circuits .....	11
4.2.1 Overview .....	11
4.2.2 Induced voltage .....	12
4.2.3 Induced current.....	13
4.2.4 Electrostatic charging .....	14
4.3 Magnetic field induction from nearby circuits.....	14
4.3.1 Induced current.....	14
4.3.2 Induced voltage .....	15
4.4 Re-energization .....	16
4.5 Mechanical risk.....	16
5 Conductor stringing methods and equipment .....	17
5.1 General.....	17
5.2 Slack stringing method.....	17
5.3 Tension stringing method.....	19
5.4 Stringing equipment.....	28
5.4.1 General.....	28
5.4.2 Tensioners.....	28
5.4.3 Pullers .....	31
5.4.4 Reel winders.....	35
5.4.5 Reel stands .....	36
5.4.6 Pilot rope puller .....	37
5.4.7 Pilot rope, pulling rope.....	37
5.4.8 Woven wire grip.....	38
5.4.9 Stringing blocks .....	38
5.4.10 Stringing rollers .....	41
5.4.11 Stringing block earth.....	42
5.4.12 Running earth.....	43
5.4.13 Hold-down block .....	43
5.4.14 Conductor car .....	43
5.5 Communications .....	47
6 Special earthing requirements .....	47
6.1 General.....	47
6.2 Work site earthing systems .....	48
6.2.1 Overview .....	48
6.2.2 Use of earth rods .....	49
6.2.3 Equipment earths.....	50
6.2.4 Earths for conductor, earth wire, metallic and synthetic rope.....	50
6.2.5 Earths for earth mat, conductors or earth wires.....	50
6.2.6 Earths for mid-span joining of conductors or earth wires .....	50

6.2.7	Earths for clipping in the conductors or earth wires .....	51
6.2.8	Earths for installation of jumper loops for the conductor .....	51
6.2.9	Stringing block earths .....	51
6.2.10	Earth mat .....	51
6.3	General procedures and use of earthing systems .....	56
6.3.1	Overview .....	56
6.3.2	General procedures .....	56
6.3.3	Installation of the pilot or pulling rope .....	57
6.3.4	Stringing of conductors .....	58
6.3.5	Splicing of conductors .....	59
6.3.6	Sagging of conductors .....	60
6.3.7	Clipping-in conductors .....	61
6.3.8	Dead-ending and installation of jumper loops .....	61
6.3.9	Spacing .....	62
6.3.10	Special work on conductors .....	62
6.3.11	Fuelling .....	63
7	Testing of earthing devices .....	63
7.1	General .....	63
7.2	Number of type tests .....	64
7.3	Type test set-up .....	64
7.4	Type test acceptance criterion .....	64
	Bibliography .....	67
	Figure 1 – Electric field induction from nearby circuits – Induced voltage .....	12
	Figure 2 – Electric field induction from nearby circuits – Induced current .....	13
	Figure 3 – Magnetic field induction from nearby circuits – Induced current .....	15
	Figure 4 – Magnetic field induction from nearby circuits – Induced voltage .....	16
	Figure 5 – Slack stringing method .....	19
	Figure 6 – <i>Tension stringing</i> method .....	27
	Figure 7 – Bullwheel tensioners .....	31
	Figure 8 – Bullwheel pullers .....	35
	Figure 9 – Stringing blocks .....	41
	Figure 10 – Stringing rollers .....	42
	Figure 11 – Conductor cars .....	44
	Figure 12 – Earthing systems .....	56
	Figure 13 – Typical test set-up for stringing block earth .....	65
	Figure 14 – Typical test set-up for running earth .....	66

## INTRODUCTION

With the increased difficulty of de-energizing existing overhead lines, installing *conductors* or *earth wire* in *circuits* nearby, or crossing these existing *circuits*, creates hazards requiring special considerations particularly with regard to earthing and bonding. It is also important to provide protections against induced static charge due to atmospheric conditions, lightning strikes, or accidental energization.

These potential electrical hazards demand that certain requirements be observed when choosing equipment and work methods for the protection of personnel or equipment.



*Indian Standard*

LIVE WORKING — GUIDELINES FOR THE INSTALLATION  
OF TRANSMISSION AND DISTRIBUTION LINE  
CONDUCTORS AND EARTH WIRES — STRINGING  
EQUIPMENT AND ACCESSORY ITEMS

( *First Revision* )

## 1 Scope

This document, which is a Technical Report, provides recommendations for the selection and testing where necessary of *conductor stringing* equipment and accessory items used for the installation of bare and insulated overhead distribution *conductors*, bare overhead transmission *conductors* and overhead *earth wires*.

Procedures are recommended for proper earthing in order to protect equipment, components and personnel from currents which can result from accidental contact with nearby *energized conductors* or from the induced or *fault currents* which can result in some circumstances.

The items of equipment under consideration in this document are used for transmission and distribution systems.

## 2 Normative references

The following documents are referred to in the text in such a way that some or all of their content constitutes requirements of this document. For dated references, only the edition cited applies. For undated references, the latest edition of the referenced document (including any amendments) applies.

IEC 60050-466, *International Electrotechnical Vocabulary – Chapter 466: Overhead lines* (available at [www.electropedia.org](http://www.electropedia.org))

IEC 60050-651, *International Electrotechnical Vocabulary – Part 651: Live working* (available at [www.electropedia.org](http://www.electropedia.org))

IEC 60743, *Live working – Terminology for tools, devices and equipment*

## 3 Terms and definitions

NOTE Terminology for equipment and procedures associated with the installation of overhead *conductors* and *earth wires* varies widely throughout the utility industry.

For the purposes of this document, the terms and definitions given in IEC 60050-466, IEC 60050-651, IEC 60743 and the following apply.

ISO and IEC maintain terminological databases for use in standardization at the following addresses:

- IEC Electropedia: available at <http://www.electropedia.org/>
- ISO Online browsing platform: available at <http://www.iso.org/obp>

### 3.1

#### **anchor**

anchor log  
deadman  
sledge  
snub

device that serves as a reliable support to hold an object firmly in place

### 3.2

#### **basket**

bucket

device designed to be attached to the boom tip of a line truck, crane or aerial lift to support workmen in an elevated working position

### 3.3

#### **birdcaging**

opening up of the outer layers of a *conductor* to form a bulge in the *conductor*

### 3.4

#### **block**

tackle  
pulley

device designed with one or more sheaves, a synthetic plastic or metal shell, and an attachment hook or shackle

### 3.5

#### **bond**

equipotential connection  
connection

electrical connection used to bring all personnel and objects in the work area to the same potential

### 3.6

#### **bullwheel**

wheel or wheels incorporated as an integral part of a *puller* or *tensioner* with multiple offset grooves allowing the continuous winding of a *conductor* or a rope to generate pulling or braking tension, through friction

### 3.7

#### **circuit**

<of an overhead line> *conductor* or system of *conductors* through which an electric current is intended to flow

Note 1 to entry: In transmission and distribution lines, a *circuit* usually consists of three phases for AC lines, and two poles for DC lines.

[SOURCE: IEC 60050-466:1990, 466-01-07]

### 3.8

#### **clearance**

minimum separation between two *conductors* operating at different voltages, between *conductors* and supports or other objects, or between *conductors* and the earth

### 3.9

#### **clipping-in**

clamping-in  
clipping

transferring of sagged *conductors* from the *stringing blocks* to their permanent suspension positions and the installing of the permanent suspension clamps



### 3.10

#### **compression joint**

conductor splice

sleeve

splice

tubular compression (or implosive) sleeves designed and fabricated from aluminium, copper or steel compressed to join or terminate *conductors* or overhead earth wires

### 3.11

#### **conductor**

cable

wire

bare or insulated wire or combination of wires, suitable for carrying an electric current

### 3.12

#### **conductor bundle**

set of individual *conductors* connected in parallel and disposed in a uniform geometrical configuration, that constitutes one phase or pole of a line

[SOURCE: IEC 60050-466:1990, 466-10-20]

### 3.13

#### **conductor car**

cable buggy

cable car

conductor trolley

line car

spacer buggy

spacing bicycle

spacer cart

device designed to carry workmen riding on sagged single or bundle *conductors*, enabling them to inspect the *conductors* for damage or install spacers, dampers or other attachments

### 3.14

#### **conductor cover**

line hose

line guard

flexible or rigid protective cover used to shroud the *conductor* providing electrical protection

### 3.15

#### **conductor clamp**

chicago grip

conductor grip

come-along

come-along clamp

preformed, bolted or wedge-type device designed to permit the pulling or temporary holding of the *conductor* or of the rope without *splicing* on fittings, eyes, etc.

### 3.16

#### **connector link**

pulling rope connector

link

peanut

fixed joint

rigid link designed to connect *pulling ropes* and usually designed to pass through the grooves of *bullwheels* on the *puller* when under load

### 3.17

#### **cradle blocks system**

system of cradle *stringing blocks*, spacer rope, *pulling rope*, a brake unit, and a radio controlled motorized tug, which use the existing *conductor* as support when installing the new *conductor*, to create a supporting protection in case of critical crossings

### 3.18

#### **crossing structure**

guard structure

H-frame

rider pole structure

scaffolding

temporary structure

*structure* built of poles, tubes, or other specialized equipment, sometimes using rope nets, used whenever *conductors* are strung over roads, power lines, communications *circuits*, highways or railroads to prevent the *conductor* from contacting any of these facilities in the event of equipment failure, broken *pulling ropes*, loss of tension, etc.

### 3.19

#### **dead**

de-energized

at an electric potential equal to or not significantly different from that of the earth at the work site

[SOURCE: IEC 60050-651:2014, 651-21-09]

### 3.20

#### **dead-ending**

procedure which results in the termination of *conductors* at an *anchor structure*

### 3.21

#### **(local) earth**

(local) ground (US)

part of the Earth which is in electric contact with an *earth* electrode and the electric potential of which is not necessarily equal to zero

[SOURCE: IEC 60050-195:1998, 195-01-03]

### 3.22

#### **earthing cable**

flexible *conductor* usually of stranded copper with a transparent cable protective sheath, and attached at both ends to clamps, designed to connect *conductors* or equipment to *earth* or to an *earth mat*

### 3.23

#### **earth clamp**

clamp forming part of an *earthing and short-circuiting* device connecting an *earthing cable*, or a *connecting cluster* to an earthing conductor, or an earth electrode or a reference potential

[SOURCE: IEC 60050-651:2014, 651-25-03]

### 3.24

#### **earth mat**

counterpoise

earth grid

system of interconnected bare *conductors* arranged in a pattern over a specified area on, or buried below, the surface of the Earth

**3.25**

**earth rod**

earth electrode

rod driven into the Earth to serve as an earthing terminal

EXAMPLE Copper-clad steel rod, solid copper rod, or galvanized steel rod.

**3.26**

**earth wire**

shield wire

skywire

static wire

*conductor* connected to *earth* at some or all supports, which is suspended usually but not necessarily above the line *conductors* to provide a degree of protection against lightning strikes

[SOURCE: IEC 60050-466:1990, 466-10-25]

**3.27**

**earthing stick**

earthing pole

insulating component equipped with a permanent or detachable *end fitting* for installing clamps, *short-circuiting bars* or *conductive extension components* onto *electrical installation*

[SOURCE: IEC 60050-651:2014, 651-25-05]

**3.28**

**earthing system**

system consisting of all interconnected earthing connections in a specific area, such as a *pull section*

**3.29**

**electromagnetic induction**

electromagnetic coupling

phenomenon that produces both an induced voltage and current either through electric or *magnetic field induction*

**3.30**

**electric field induction**

capacitive coupling

process of generating voltages and/or currents in a conductive object or electrical *circuit* by means of time-varying electric fields

**3.31**

**energized**

alive

current-carrying

hot

live

at a potential significantly different from that of the *earth* at the work site and which presents an electrical hazard

Note 1 to entry: A part is *energized* when it is electrically connected to a source of electric energy. It can also be *energized* when it is electrically charged under the influence of an electric or magnetic field.

[SOURCE: IEC 60050-651:2014, 651-21-08]

**3.32**

**equipotential**

set of points all of which have the same potential

**3.33**

**factor of safety**

ratio of *ultimate strength* or *yield strength* to the maximum allowable applied force or load

**3.34**

**fault**

physical condition that causes a device, a component, or an element to fail to perform in a required manner

**3.35**

**fault current**

earth fault current

current flowing at a given point of a network resulting from a *fault* at another point of this network

**3.36**

**hold-down block**

block designed to prevent uplift and to maintain the *pilot rope* or *conductor(s)* inside the sheaves of the *stringing block* installed on the tower

**3.37**

**isolated**

<device or *circuit*> disconnected completely from other devices or *circuits*, and thus separated physically, electrically and mechanically from all sources of electrical energy

Note 1 to entry: Such separation may not eliminate all effects of *electromagnetic induction*.

**3.38**

**joint protector**

joint stiffener

sleeve protector

splice protector

cover joint

split sleeve which fits over a *compression joint* or splice, and is used to protect the *compression joint* from bending or damage if the joint passes through *stringing blocks*

**3.39**

**jumper**

dead end loop

*conductor* that connects the *conductors* on opposite sides of a dead-end *structure*

**3.40**

**magnetic field induction**

inductive coupling

process of generating voltages and/or currents in an electrical *circuit* by means of time-varying magnetic fields

**3.41**

**pilot rope**

lead line/rope

leader

P-line/rope

straw line/rope

pre-pilot rope

lightweight rope, either wire rope or synthetic fibre rope, used to pull heavier *pulling ropes* which in turn are used to pull the *conductor*

**3.42**

**pilot rope puller**

device designed to payout and rewind *pilot ropes* during *stringing* operations

**3.43**

**portable earth interrupter tool**

portable switching device designed to break high circulating currents, and which prevents an unmanageable large arc from occurring in the removal of the last *earth* in an *earthing system*

**3.44**

**pull section**

pull setting

stringing section

section of line where the *conductor* is being pulled into place by the *puller* and *tensioner*

**3.45**

**pull site**

puller set-up

location in a *pull section* where the *puller*, *reel winder* and anchors (snubs) are located

**3.46**

**puller**

drum

hoist

tugger

equipment designed to pull *pulling ropes* during *stringing* operations

[SOURCE: IEC 60743:2013, 14.1.3, modified — Admitted terms have been changed, "conductor(s)" has been deleted from the definition, and Notes to entry have been deleted.]

**3.47**

**puller-tensioner**

equipment designed to pull *pulling ropes* or *conductor(s)* or to hold mechanical tension against a *pulling rope* or *conductor(s)* during *stringing* operations

[SOURCE: IEC 60743:2013, 14.1.5, modified — Notes to entry have been deleted.]

**3.48**

**pulling rope**

bull line/rope

hard line/rope

sock line/rope

anti-twisting braided rope

high strength rope, normally steel wire rope or less frequently synthetic fibre rope, used to pull the *conductor*, with formation and construction that ensure non-twisting capability under pull operation

**3.49**

**pulling vehicle**

pulling tractor

towing vehicle

piece of mobile ground or air borne equipment capable of pulling *pilot ropes*, *pulling ropes* or *conductors*

**3.50**

**reel stand**

reel elevator

reel trailer

reel truck

drum stand

drum elevator

device designed to support one or more reels and having the possibility of being skid, trailer or truck mounted

**3.51**

**reel winder**

takeup reel winder

takeup stand

takeup winder

machine designed to work in conjunction with a *bullwheel puller* or *puller-tensioner*, and to serve as a recovery unit for the *pulling rope*

**3.52**

**running board**

headboard

pulling device designed to permit *stringing* several *conductors* simultaneously with a single *pulling rope*

[SOURCE: IEC 60743:2013, 14.2.3, modified — Notes to entry have been deleted.]

**3.53**

**running earth**

earthing roller

moving earth

rolling earth

travelling earth

portable device designed to connect a moving *conductor* or a pulling/*pilot rope* to an electrical *earth*

[SOURCE: IEC 60743:2013, 14.2.1, modified — In the definition, "used" has been replaced by "designed", and Note 1 to entry has been deleted.]

**3.54**

**sagging**

process of pulling *conductors* up to their final tension or sag

**3.55**

**slack stringing**

method of *stringing conductor(s)* slack without the use of a tensioner, with some minimal braking applied to the *conductor* reel

**3.56**

**spacing**

spacing

process of installing the spacers between the bundle *subconductors* in each phase

**3.57**

**splicing**

jointing

process of joining the ends of *conductor* lengths to form a continuous mechanical and electrical connection

**3.58**

**stringing**

process of pulling *pilot ropes*, *pulling ropes* and *conductors* over *stringing blocks* supported on *structures* of overhead lines

**3.59**

**stringing block**

block

conductor running block

dolly

running out block

sheave

stringing sheave

stringing traveller

traveller

pulley

sheave, or sheaves, complete with a frame used separately or in groups and suspended from *structures* to permit the *stringing of conductors*

[SOURCE: IEC 60743:2013, 14.2.2, modified — Note 1 to entry has been deleted.]

**3.60**

**stringing block earth**

conductor running block earth

sheave earth

traveller earth

portable device attached to a *stringing* block and designed to connect a moving conductor or pulling/*pilot rope* to an electrical *earth*

**3.61**

**structure**

pole

tower

tower or pole which supports the *conductors* on insulators, usually steel lattice or tubular type for transmission line and wood, metal, synthetic, or concrete for distribution line

**3.62**

**subconductor**

each *conductor* in a *conductor bundle* arranged in a vertical, horizontal, square, round, or other suitable configuration

**3.63**

**swivel**

bullet, swivel joint

device joining one *pulling rope* to a *conductor* or *conductors* to a *running board* relieving torsional forces on conductors

### 3.64

#### **tension site**

conductor payout station

payout site

reel set-up

tensioner set-up

location on a *pull section* where the tensioner, *reel stands*, conductor reels and *anchors* (snubs) are located

### 3.65

#### **tension stringing**

process of using *pullers* and tensioners to give the *conductor* sufficient tension and positive control during the *stringing* operation to keep it clear of the ground surface and other obstacles which could cause damage to the surface of the *conductor*

### 3.66

#### **tensioner**

bullwheel tensioner

brake

retarder

equipment designed to hold mechanical tension against a *pulling rope* or *conductor(s)* during the *stringing* operation

[SOURCE: IEC 60743:2013, 14.1.2, modified — Note 1 to entry has been deleted.]

### 3.67

#### **tractor**

cat

crawler

sag tractor

tracked unit employed to pull *pulling/pilot ropes*, *sag conductors*, at clear pull and *tension sites* and provide a temporary *anchor*

### 3.68

#### **ultimate strength**

breaking strength

strength of a member or of part of an assembly at which failure of that member or part of the assembly occurs, with the result that it can no longer support a load or perform its intended function

### 3.69

#### **working load limit**

allowable load

maximum load

safe working load

limit of load that can be imposed safely on a member or assembly usually calculated by dividing the ultimate or breaking strength by the accepted *factor of safety*

### 3.70

#### **woven wire grip**

kellem

mesh sock

sock

stocking

wire mesh grip

device designed to allow the temporary joining or pulling of *conductors* without the need of special eyes, links or grips



### 3.71

#### yield strength

strength of a member or of part of an assembly at which permanent deformation of that member or part of the assembly occurs, with the result that it can no longer perform its intended function

## 4 Understanding the hazard – Basic theory

### 4.1 General

The protection of personnel from injury during the process of installing *conductors* on transmission and distribution lines is most important, both for electrical and mechanical risk.

For electrical risk, the personnel at the work site installing these new *conductors* shall be protected against induced voltages and currents caused by *energized* adjacent lines. The personnel shall also be protected from the hazards which can result from accidental line energization. Personnel protection can be achieved by properly applying adequate protective *earthing systems* at the work area, by the use of correct work methods and specialized training, and by the use of equipment which incorporates devices to protect against these types of hazards.

Electrical charges or voltage may appear on a *conductor* being installed, or on the other equipment and components such as the ropes involved in the *conductor stringing* process, due to one or more of the following factors:

- a) *electromagnetic induction* (i.e. capacitive and/or inductive coupling) from adjacent *energized* lines, or when crossing over *energized* lines;
- b) accidental contact of the *conductor* or ropes being installed, with an existing adjacent *energized* line; this is the most likely cause of electrical hazard when working on distribution lines in crowded urban areas where existing *circuits* cannot be shut down;
- c) electrostatic charging (i.e. conductive coupling) of the *conductors* or ropes by atmospheric conditions or by an adjacent high voltage direct current (HVDC) transmission line;
- d) switching error in which the *conductor* being installed is accidentally *energized*;
- e) lightning strikes in the vicinity, or a lightning strike to the *conductor* being installed or other equipment and components such as the ropes involved in the *stringing* process.

The hazards caused by lightning strikes, accidental contact with a live line and switching errors are generally understood. However, the hazards caused by induced voltages and currents are probably less understood and are therefore explained in some detail here. It is important to note that the basic difference between the hazard caused by induction, and the other sources given above is that the induction is continuous as long as the source line is *energized*, rather than instantaneous or transient in the case of lightning or a *fault current*.

For mechanical risk, the personnel shall be protected against unexpected breaking of the pulling line elements, movement of the equipment under load, handling of material, lifting of material and tools on the tower, working activity at height.

NOTE In the following examples, induction is shown as occurring on a *conductor*; however, the same result and hazard will occur for other components used in the *conductor stringing* process, such as conducting (metallic) pulling or *pilot ropes*, or *earth wires*.

### 4.2 Electric field induction from nearby circuits

#### 4.2.1 Overview

There are two common types of induction problems caused by nearby *energized* AC lines: electric field and magnetic field. Each has both voltage and current implications.

If the nearby line is an *energized* DC transmission line, the induced voltage is the result of ion drift, and can result in even higher voltages than if the nearby line were an AC line. Magnetic induction would only be related to the ripple effect, and is therefore much less than would be the case if the nearby line were an AC line.

#### 4.2.2 Induced voltage

The electric field around an *energized conductor* produces a voltage on an *isolated and unearthened* conducting object nearby (see Figure 1).

The voltage produced depends on the source voltage magnitude and the geometry of the system but not on the length of the parallel between the *energized* line and the new *conductor* being installed.

If the *circuit* is unearthened, the induced voltage may be as much as 30 % of the *energized* line voltage. This induced voltage can be calculated, but it is generally not necessary to do so. If the new *conductor* being installed is earthed at any point, the charge is reduced to a much lower steady state value, depending on the resistance to *earth* of the *earth* path.

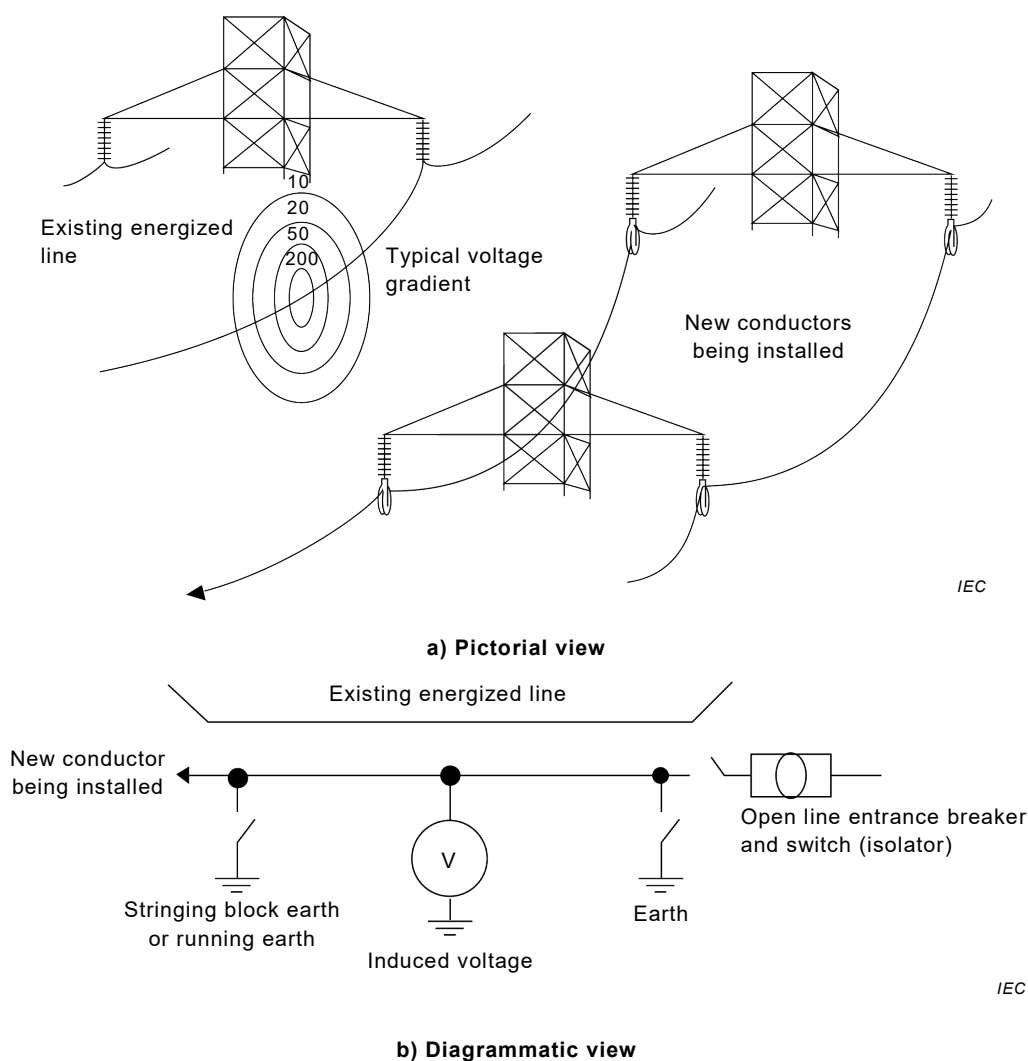

NOTE These figures are simplified. The three phases of the existing *energized* line are involved in the induction.

**Figure 1 – Electric field induction from nearby circuits – Induced voltage**

### 4.2.3 Induced current

With an AC system, the *energized* lines and the earthed *conductor* being installed act like the plates of a condenser or capacitor, and a charging current flows across the air gap between them (see Figure 2).

The two following aspects should be considered.

- A current flows through the temporary *earth* from the *conductor* to *earth*. It is proportional to the length of the parallel between the *energized conductor* and the new *conductor* being installed. This current may amount to several amperes.
- If the temporary *earth* becomes defective, is dislodged, or removed, the capacitive voltage is immediately re-established. Thus, if a worker is in fairly solid contact with the system and the only *earth* is dislodged, the worker can be exposed to a dangerous voltage and current. If the worker attempts to contact the *conductor* or connected parts, he will receive a dangerous discharge current, followed by a steady-state current. Thus, the worker shall avoid coming in close proximity to the *conductor* or connected parts since the induced voltage may be high enough to cause arc-over. Also, it should be noted that the steady-state capacitive current occurring after the contact may reach a dangerous level.

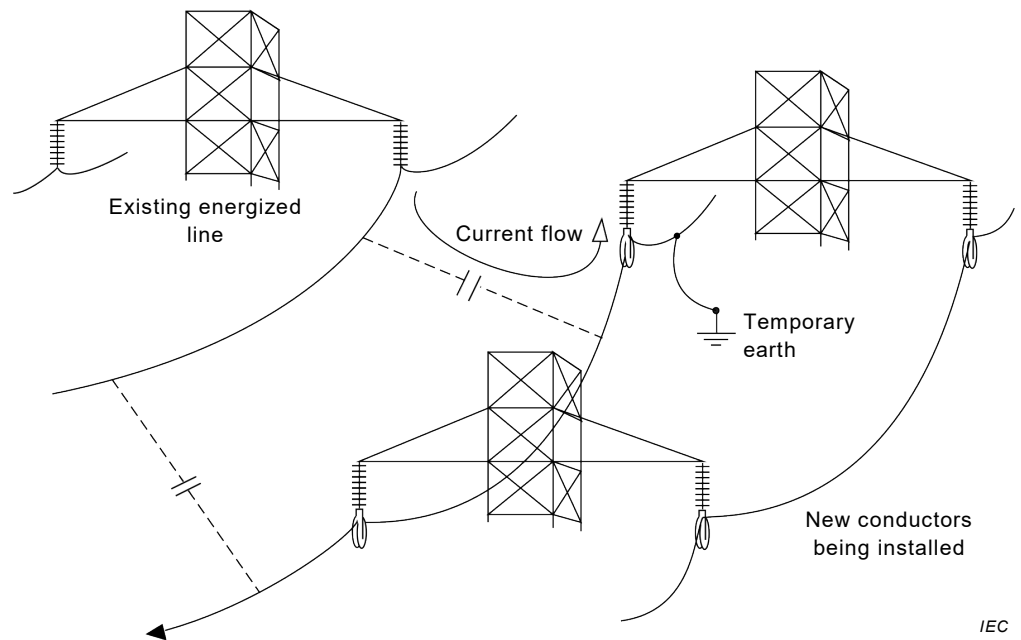

a) Pictorial view

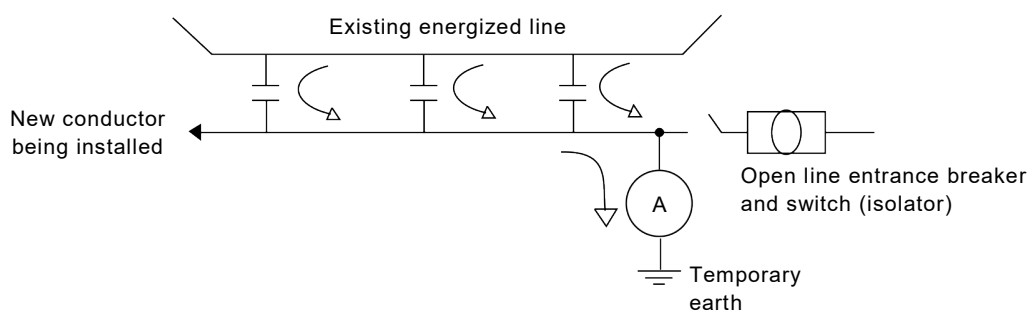

b) Diagrammatic view

NOTE These figures are simplified. The three phases of the existing *energized* line are involved in the induction.

**Figure 2 – Electric field induction from nearby circuits – Induced current**

#### 4.2.4 Electrostatic charging

It should be noted that a potential hazard exists where a line to be worked on is still insulated but has been *isolated*, as it may have a voltage due to electrostatic charging resulting from atmospheric conditions, or trapped charges from switching. Therefore, before starting any work operation on the distribution line, it shall be earthed at least at one point to discharge the electrostatic charge.

### 4.3 Magnetic field induction from nearby circuits

#### 4.3.1 Induced current

In addition to the electric field caused by the voltage of the adjacent *energized* line, another effect is caused by the current flowing in the *energized* line.

The *energized*, current-carrying *conductor* and the nearby *conductor* being installed may be looked upon as the primary and secondary windings of an air-core transformer.

If the new *conductor* is earthed at two places, it acts like the secondary of an air-core transformer, short-circuited through the *earth*. A circulating current will flow along the new *conductor*, through one *earth* connection, back through the *earth* and up the other *earth* to complete the loop (see Figure 3a).

This electromagnetic current is proportional to the current in the *energized* line and is dependent on the geometry and impedance of the system.

If a series of *earths* is applied, a series of loops is formed, each carrying current (see Figure 3b).

It would appear that the currents would cancel in the intermediate *earths*.

If there is a great difference in impedance of the *earths* in adjacent loops, for example a lake in the *earth* return of one, and rock in the other, the intermediate *earth* can carry almost the full circulating current.

If there are transpositions in the *energized circuit*, the phase angle of the induced current will be different along the line and can also create large circulating currents in the *earthing system*.

When work is being done in the vicinity of a heavily loaded *energized* line, or a *fault* occurs on the adjacent *energized* line, the current induced in the new *conductor* being installed can be very large and can affect the choice of earthing assemblies.

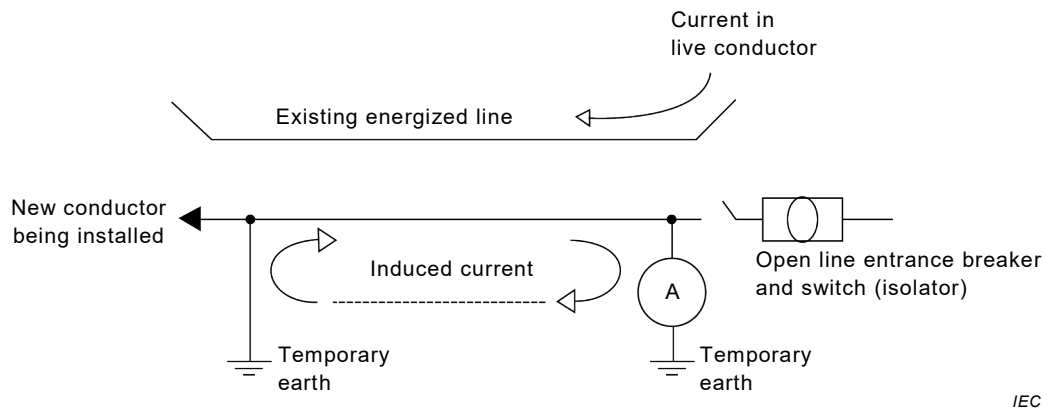

a) Two earths on new conductor allow circulating current to flow

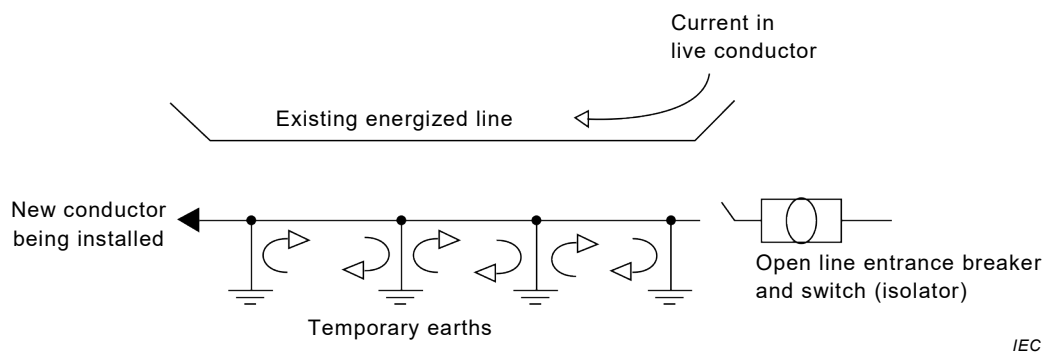

b) Circulating currents with multiple earths

NOTE These figures are simplified. The three phases of the existing *energized* line are involved in the induction.

**Figure 3 – Magnetic field induction from nearby circuits – Induced current**

#### 4.3.2 Induced voltage

Continuing the analogy of an air-core transformer, if the new *conductor* being installed becomes earthed at one point only, for example by the removal of the last but one temporary *earth*, an open *circuit* secondary voltage to *earth* appears on the line. This voltage is essentially zero at the location of the remaining *earth*, and increases in proportion to the length of the parallel (Figure 4a).

At the moment of removing the last but one *earth*, the circulating electromagnetic current is broken and a voltage appears across the gap. This voltage can become dangerously high, in the case of a long parallel between the *energized* line and the new *conductor* being installed. It may have to be limited by a technique of sequential earthing, in which the new *conductor* is subdivided by intermediate *earths*. The sections are then short enough to limit the open *circuit* voltage because the *earths* are sequentially removed (Figure 4b).

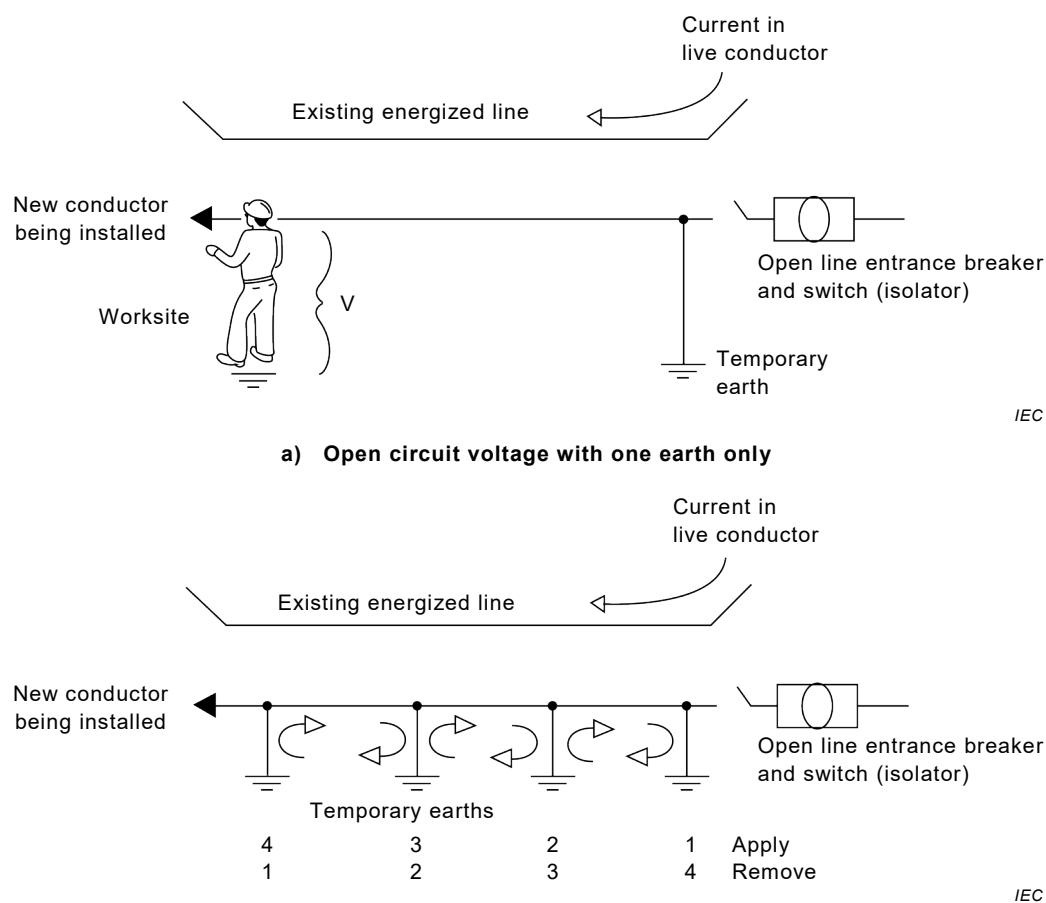

In area of high induction, removal of the last *earth* should be done with a *portable earth interrupter tool*.

**Figure 4 – Magnetic field induction from nearby circuits – Induced voltage**

#### 4.4 Re-energization

Accidental contact with an *energized conductor*, or a switching error, may occur. Therefore, appropriate *earthing systems*, such as *equipotential earth systems*, shall be applied on each site, as it is not sufficient to rely on remote earths applied when the line was regionally *isolated* and earthed.

#### 4.5 Mechanical risk

To avoid any unexpected breaking of the pulling line elements, it has to be considered that the maximum pull applied usually is different from the one applied at the tensioner or at the puller, depending on the design of the line and the orography of the line path. In particular, in case of mountainous area, the maximum value of the pull force applied could be much greater, as well as the balance between clipped conductor and conductor on blocks that are totally different, and this requires care in the equipment selections. Moreover, tension values should be close to the sagging tension values when crossing existing lines where limited clearance must be respected.

To avoid unexpected movement of the equipment under load, the requirement provided by the equipment manufacturer has to be carefully applied. It is evident that the weight of the equipment is normally not enough to grant the stability under load, but it looks like this elementary requirement is sometimes not really considered in the risk assessment.

Operation involving handling of material, lifting of material and tools on the tower or working activity at height are normally detailed in the safety procedure and instruction for all open job-site activities; it is important to know them and to follow in detail the safety instruction to avoid any danger situation.

## 5 Conductor stringing methods and equipment

### 5.1 General

The *stringing* methods used to install the *conductor* (including *earth wire*) currently employed in the electric power industry are many and varied. Outlined below are the basic methods currently in use, but they are invariably modified to accommodate equipment readily available. The methods also depend somewhat on the type and size of the line to be built, and the ground over which the line is to be built.

Installation of transmission *conductor* is made by *stringing* one phase (one or more *subconductors* in bundle) at a time, by using a multi-conductor *tensioner* and a *running board*. The *running board* is smoothly shaped to pass through the *stringing block* and usually has a flexible pendulum tail suspended from the rear to prevent the *conductor bundle* from twisting during the pulling process. The *conductors* and *pulling rope* are normally connected to the *running board* with *swivels* to prevent twisting loads being transferred to the *running board*. The rope formation and construction shall grant non-twisting capability under pull operation. *Swivels* are not designed to pass through the *bullwheels* of a *puller* or a *tensioner* under any significant load.

*Stringing blocks* are sometimes bundled with a centre sheave for the *pulling rope* and two or more *conductor* sheaves, and used to string more than one *conductor* simultaneously. For mechanical protection of *conductors*, sheaves are often lined with non-conductive or semiconductive polychloroprene, polyurethane or other elastomer, or polyamide. Where conductivity of the *stringing block* is required, the lining should be made of aluminium.

Installation of distribution *conductors* can be made one *conductor* (phase) at a time; however, it is possible to install all three phases plus neutral at one time with a multi-conductor *tensioner* and a *running board*. Insulated *conductors* may be in the form of three or four *conductors* with a messenger wire twisted together as a bundle. This bundle is usually installed on the *structures* in the same manner as one *conductor*.

Temporary *anchors* are often used at pull and *tension sites*. The term *anchor* is normally associated with cone, plate, screw or concrete *anchors*, but the terms snub, deadman and *anchor log* are usually associated with pole stubs or logs set or buried in the ground, to serve as temporary *anchors*. A sledge with blocks of concrete sitting on top of the ground and of sufficient weight to hold the load has also served as a temporary *anchor*.

There are some mechanical and electrical characteristics which are important in the choice of *stringing* equipment. They are detailed in Clause 5.

### 5.2 Slack stringing method

The *slack stringing* method is illustrated in Figures 5a and 5b.

The *slack stringing* method is not recommended for installation of transmission line *conductors*, because surface damage to or contamination of the *conductor* using this installation process can be quite high, causing corona losses and excessive radio, TV and communication interference.

The method shall be used for installation of distribution line *conductors* where applicable; anyway, this method is not recommended in areas where high induction is possible.

There are two commonly used methods for *slack stringing*.

a) Stationary reel method

This method is when the *conductor* reels are located at one end of the *pull section*. The *conductor* is dragged along the ground of the right of way by means of a towing vehicle (see Figure 5a).

b) Rolling reel method

Another variation of the *slack stringing* method is when the reels are towed along the right of way on a trailer behind a towing vehicle, and the *conductor* is deposited on the ground (see Figure 5b).

The *conductor* reels are held in *reel stands* either placed on the ground or mounted on a trailer. These stands are designed to support the reel on a shaft, permitting it to turn as the *conductor* is pulled out. Usually a braking device is provided to prevent overrunning of the reel when the pulling is stopped.

When the *conductor* is towed past each supporting *structure* or tower, the towing vehicle is stopped and the *conductor* placed in *stringing blocks* attached to the *structure* before proceeding to the next *structure*.

This method is chiefly applicable to the construction of rural distribution lines, where the line right of way is easily accessible to a towing vehicle. The method is not practical to use in congested urban locations where hazards exist from traffic or where there is danger of contact with *energized circuits*. Nor is it practical in mountainous regions where the towing vehicle cannot proceed along the right-of-way.

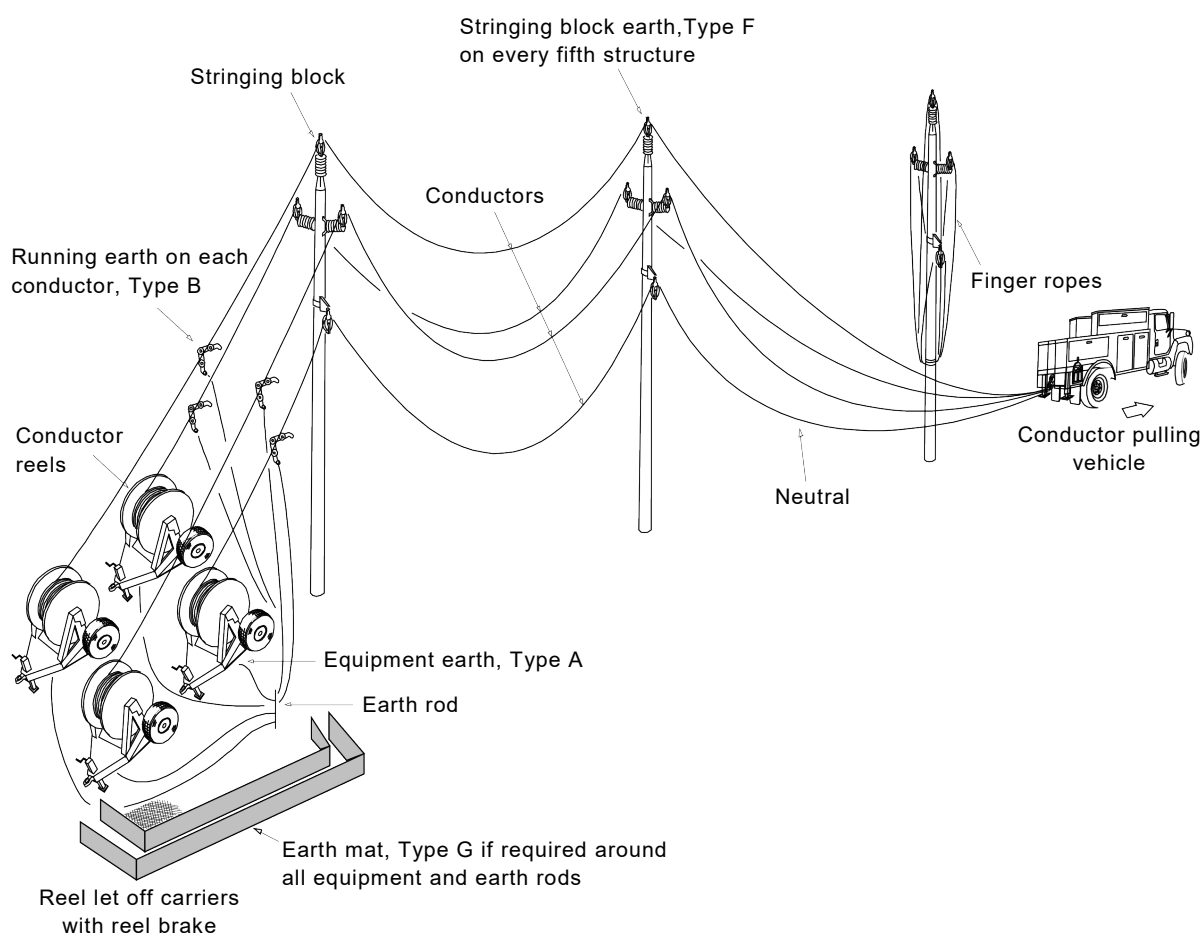

IEC

a) Installing conductor – Stationary reel



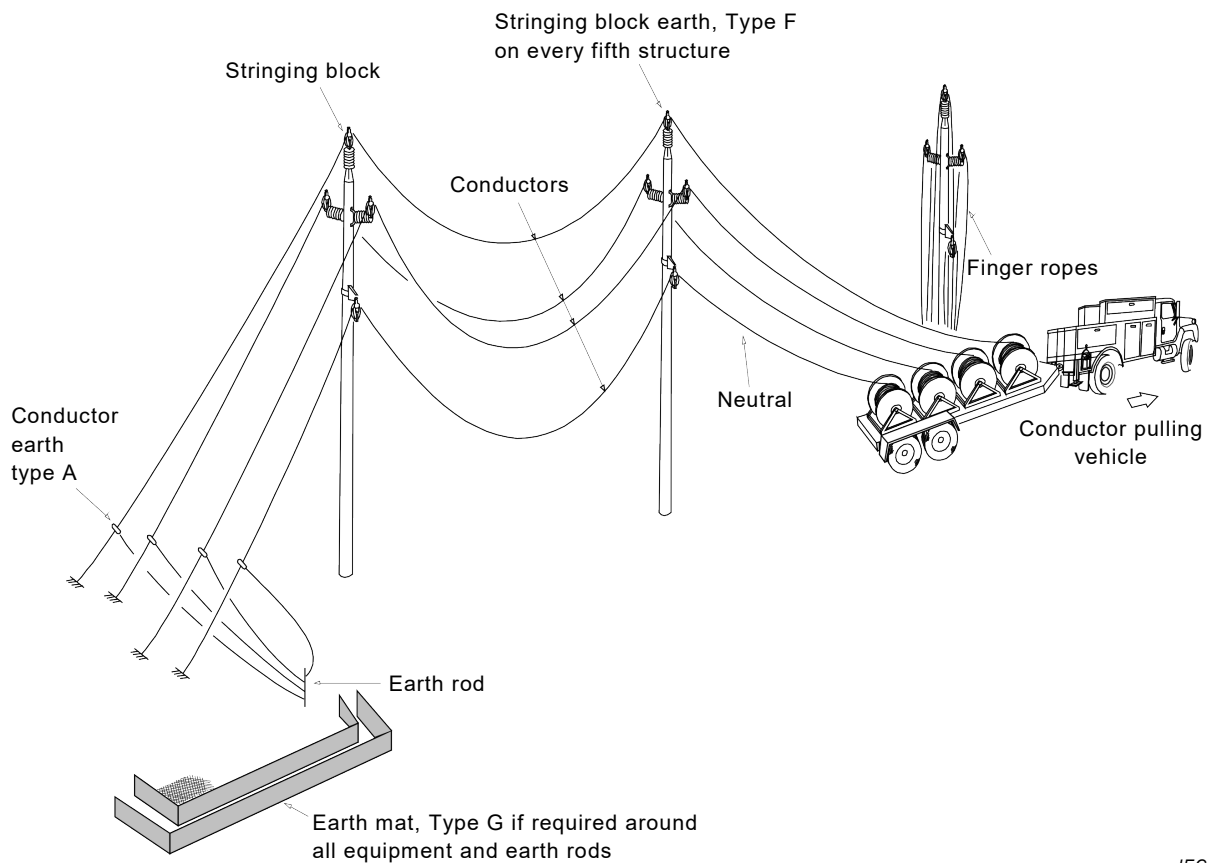

IEC

b) Installing conductor – Rolling reel

Figure 5 – Slack stringing method

### 5.3 Tension stringing method

The *tension stringing* method is applicable for both transmission and distribution lines, and shall be considered the state of the art of the *conductor* installation methods.

This method is illustrated in Figures 6a to 6d for distribution lines and Figures 6e to 6m for transmission lines.

Using this method, the *conductor* is kept under tension during the *stringing* process to keep the *conductor* from contacting the Earth surface or other obstacles between towers since this will cause *conductor* surface damage. The tension in the *conductor* also allows it to pass over *energized circuits*, railway or major road crossings, etc. without contacting them.

For multiconductor per phase lines, the *tension stringing* method requires the installation of a light synthetic or metallic *pilot rope* into the *stringing blocks*. This is normally done using the *slack stringing* stationary reel method by either a towing vehicle or a helicopter or a drone. The *pilot rope* is used to pull in a heavier *pulling rope*, and the *pulling rope* is then used to pull in the *conductors*.

For single *conductor* per phase installations, the *pulling rope* may be installed directly with a towing vehicle or by helicopter eliminating the use of a *pilot rope* completely.

All the *subconductors* of each bundle are strung at the same time and with the same tension applied, to avoid difference sag behaviour once installed.

The first and most common method for *tension stringing conductors* is to use one or more *tensioners*, depending on the number of *subconductors* in a bundle, and one *puller*. This methodology can be named as “1 by  $n$ ”, where 1 means one *pulling rope* and  $n$  means the number of *subconductors* of the bundle (see Figure 6i).

In case of a large number of *subconductors* in a bundle, another possible *stringing* methodology is to provide a *pulling rope* for each *conductor*, by using one or more *tensioners* and one or more *pullers*. This methodology can be named as “ $n$  by  $n$ ”, where the first  $n$  means the number of *pulling ropes* and the second  $n$  means number of *subconductors* in the bundle (see Figure 6j).

Where a transmission line is to be reconducted, often the old *conductor* is used as a *pulling rope* to pull in the new *conductor*, and the *puller* machine becomes a *puller-tensioner* machine. This methodology is equivalent to the previous “ $n$  by  $n$ ” method, where the first  $n$  means the number of old *subconductors* used as a *pulling rope* and the second  $n$  means the number of *subconductors* in the bundle (see Figure 6k).

An alternative method for reconducting operations, when the mechanical strength of the old *conductor* is not well predictable, is to use a *pulling rope* as a tensioning element while recovering the old *conductor*, in order to keep them suspended from the ground and to minimize the tension value in the old *conductor*. Then the installed rope can be used as a pilot or *pulling rope* for the new *conductor* installation. This methodology can be named as “ $n$  by 1” method, where  $n$  means the number of old *subconductors* to be recovered and 1 means one tensioning rope to be used to keep tension in the old *conductor bundle*.

Since the mechanical strength of the old *conductor*, and particularly the *compression joints*, may be very questionable, this procedure may require extra caution. Passing old joints around the *bullwheels* of the *puller-tensioner*, where they are bent and then straightened as the joints pass from groove to groove on the *bullwheels*, can cause sudden failure of the joints and the *conductor* may drop, causing damage to the *conductor* or the line *structures*, and therefore is not recommended. A common procedure is to cut out the *compression joint* when it arrives in front of the *puller-tensioner*, and to fit a *woven wire grip* on both ends of the severed *conductor*. This grip is passed through the *bullwheels*, and can be removed before the *conductor* is wound on the *reel winder*.

The same procedure is applied in case of *earth wire* replacement, when several sections of *earth wire* are included in a stringing section: the compression joints or the tension clamps of single sections should be removed and both ends of the *earth wire* should be connected with a woven wire grip.

Recent development of *stringing* technology has also allowed to adopt a combination of the two previous methods in *stringing* new power lines, in particular in case of a large number of bundle conductors (from 6 up to 8 or 10), so we can have a “ $2 \times (1 \times n)$ ” method, where two traditional *stringing* methods “ $1 \times n$ ” can be coupled to reach the total number of *subconductors* of the bundle (see Figure 6n).

Due to the increase of the number of *subconductors* in a bundle, in the previous methodologies the use of a large number of *stringing* machines is requested.

All the machines working combined at the same station (example two or more *tensioners* at the *tensioner* station, two or more *pullers* or *puller-tensioners* at the *puller* station) will be provided with suitable electronic connection to allow them to be operated by a single operator controlling all the working parameters, to avoid any unbalancing effect on each *subconductor* of the bundle.

In case of double (or multiple) *circuit* power lines, it is becoming popular to operate with one of the *circuits energized* and the other *circuit* being strung or reconducted (see Figure 6m). The nearby *energized circuit* will generate severe induced current effect on the line being

strung and therefore the equipment shall be installed and used by assuring the *equipotential* condition of the entire working area.

In case of wind, take care of the displacement of *conductors* and the possibility of reducing the clearance between the moving *conductors* and the live *conductors* to prevent any arcing.

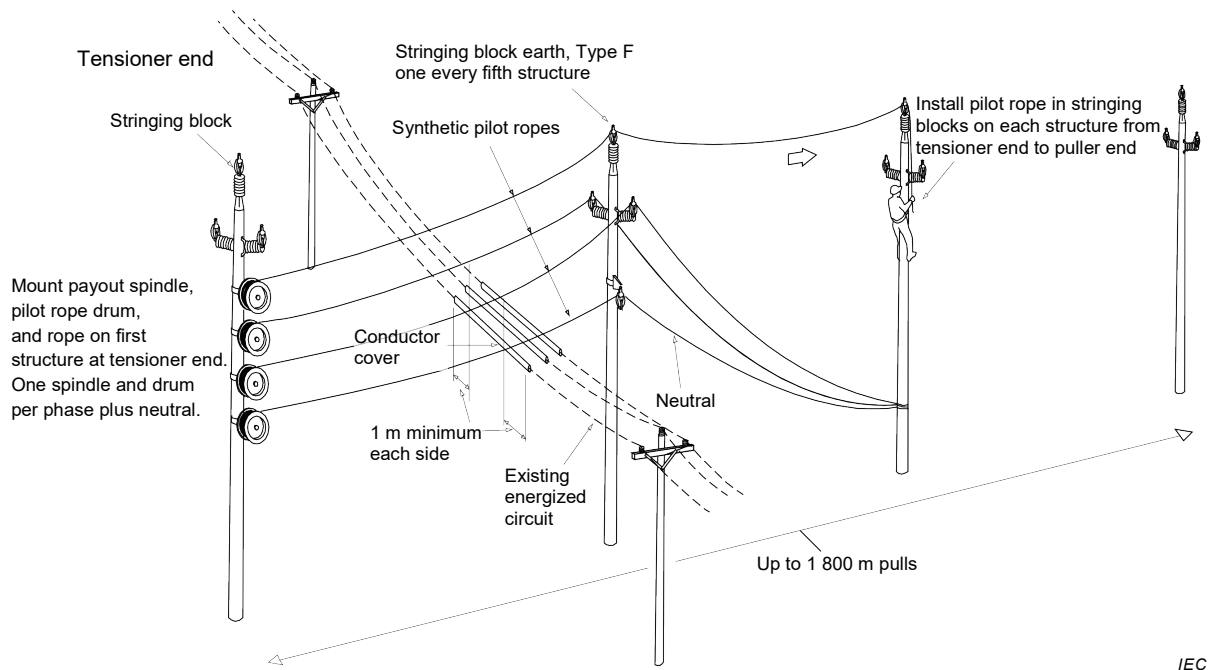

a) Distribution – Installing pilot rope on structure

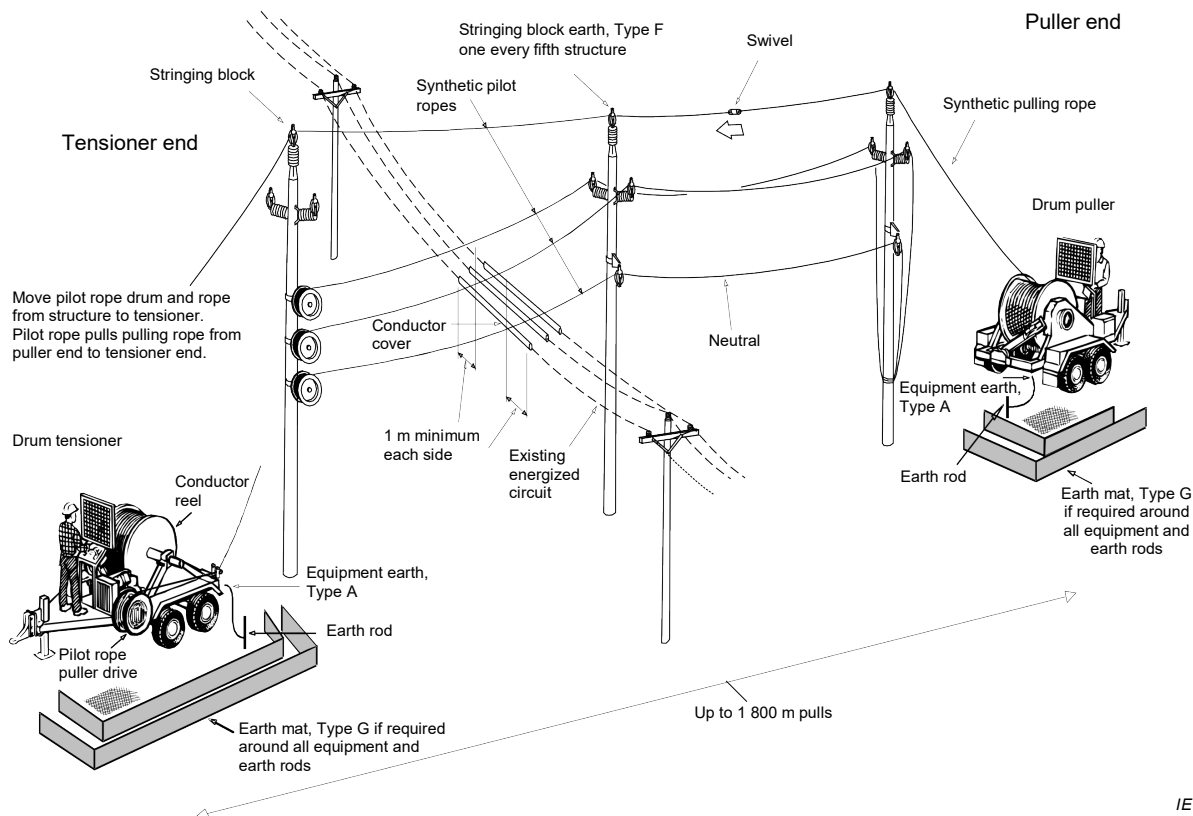

The *puller* and *tensioner* shall be located at a minimum distance from the first and last *structures* of three times the height of the *stringing block* above the machines.

**b) Distribution – Installing the pulling rope**

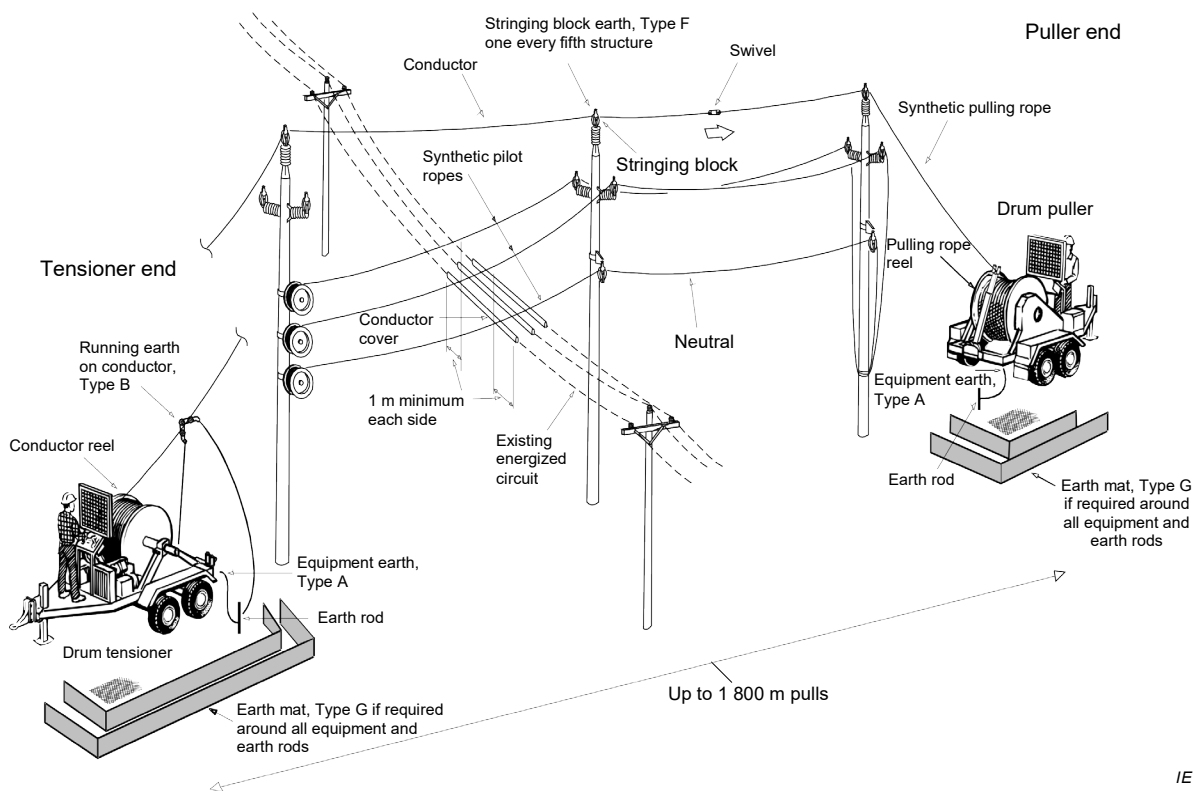

The *puller* and *tensioner* shall be located at a minimum distance from the first and last *structures* of three times the height of the *stringing block* above the machines.

**c) Distribution – Installing conductor**

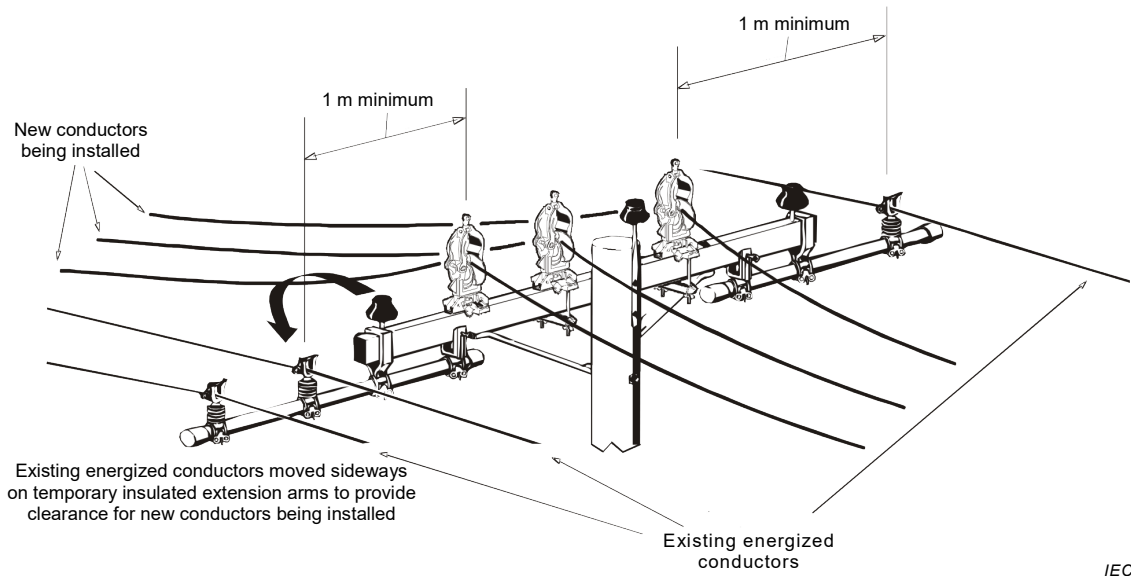

**d) Distribution – Reconductoring project with existing circuit energized**

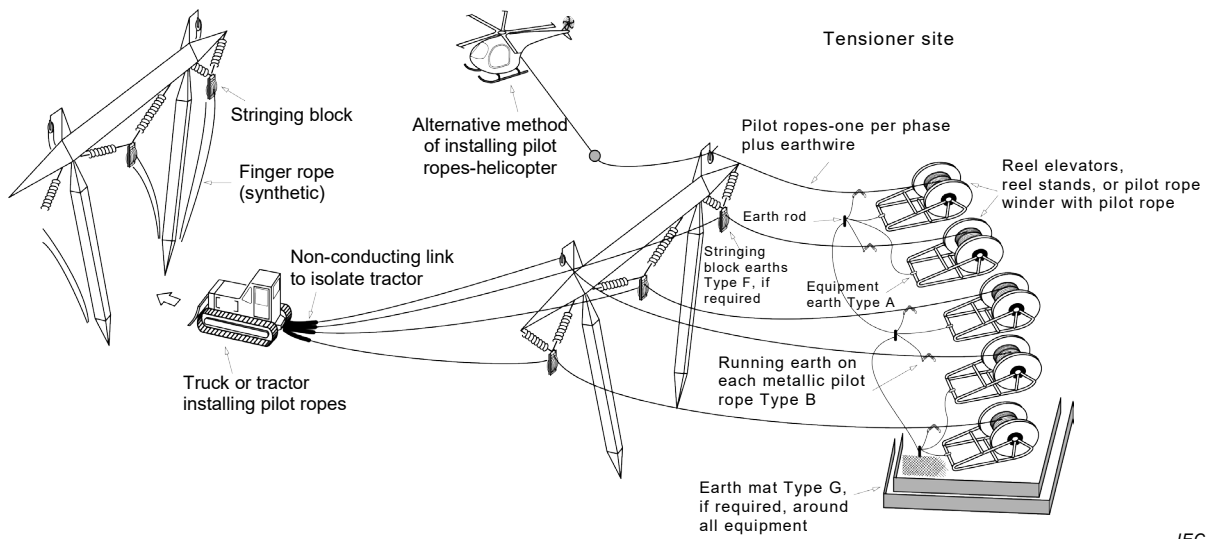

**e) Transmission – Installing the pilot ropes**

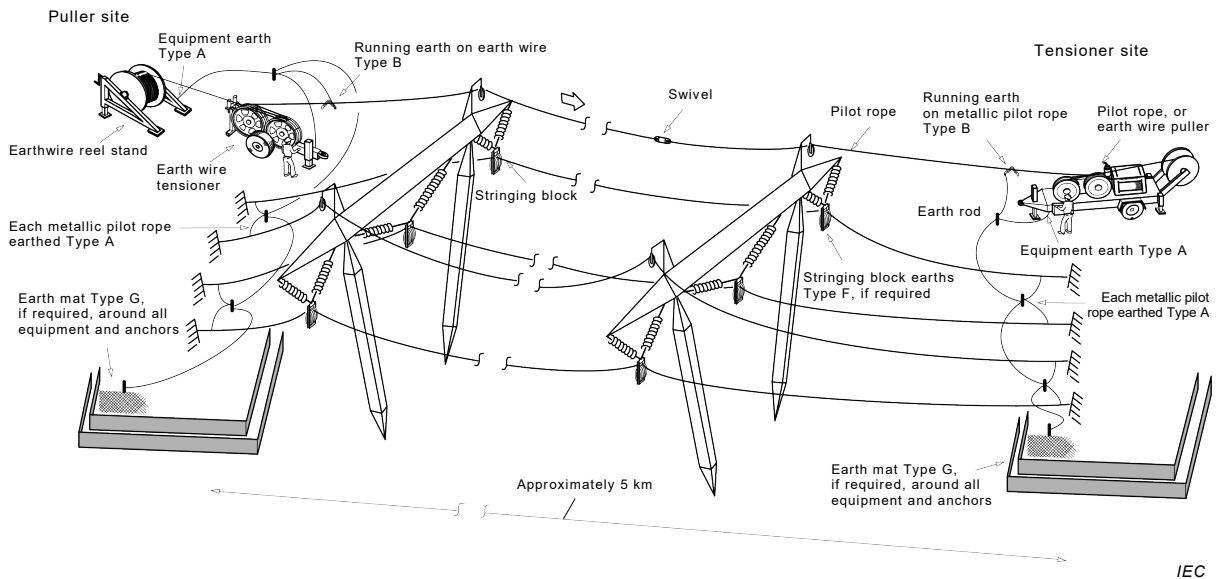

f) Transmission – Installing the earth wire

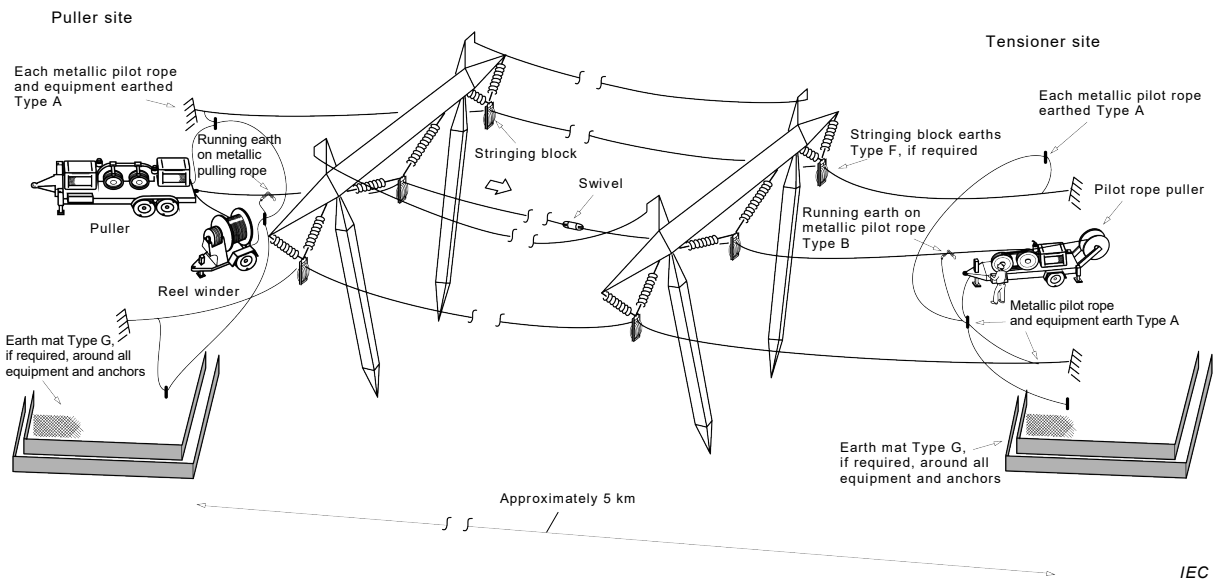

g) Transmission – Installing pulling rope in first phase

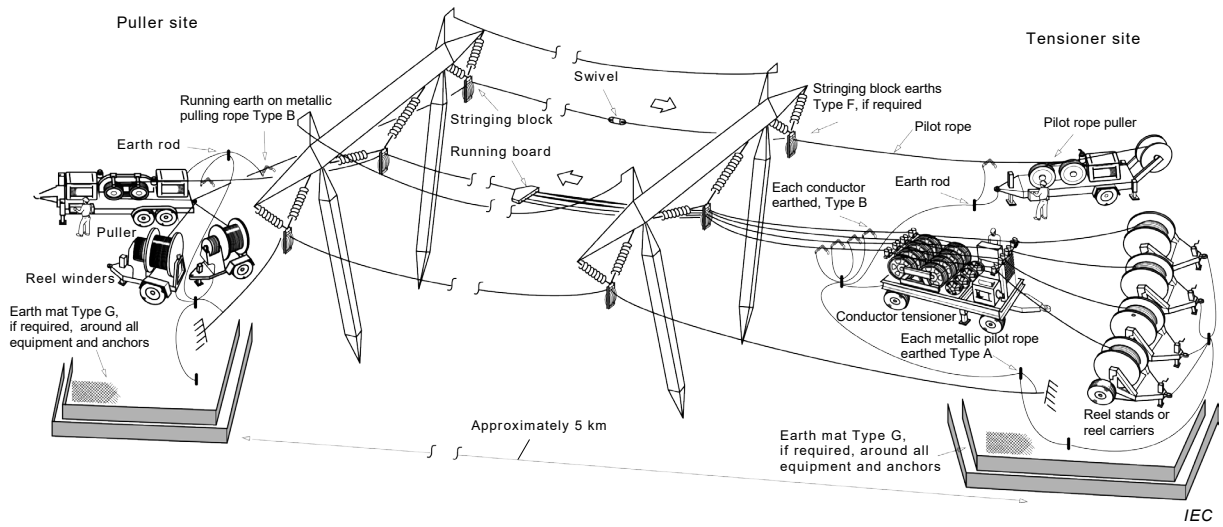

**h) Transmission – Installing conductor in first phase**

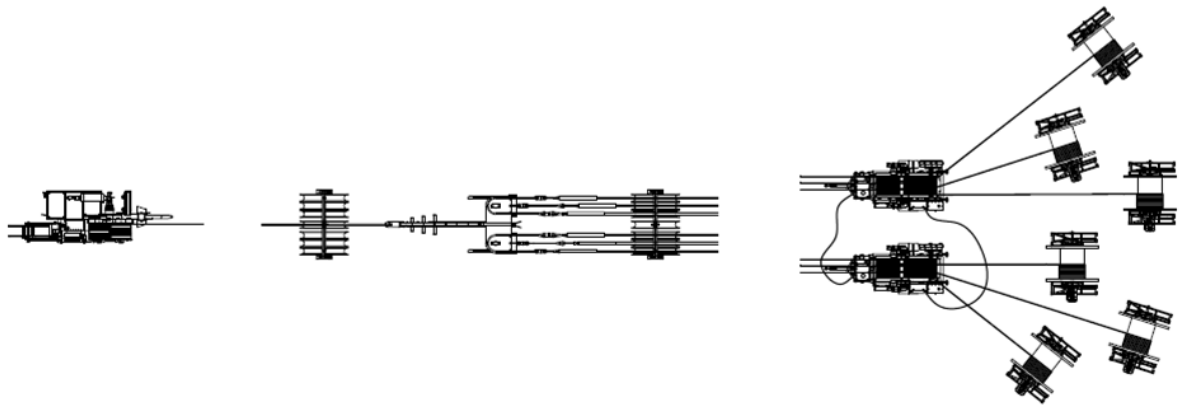
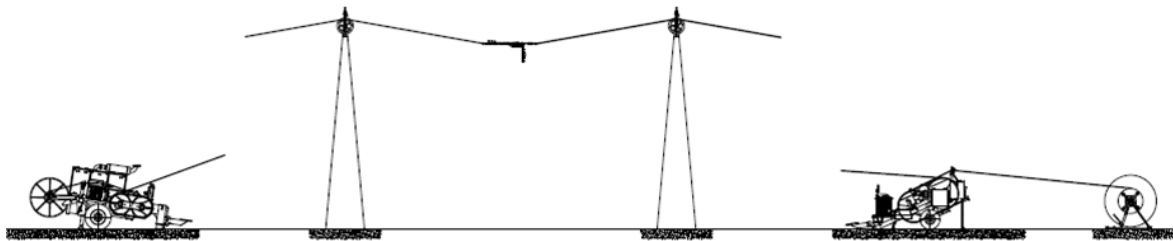

**i) Transmission – 1 × n stringing method**

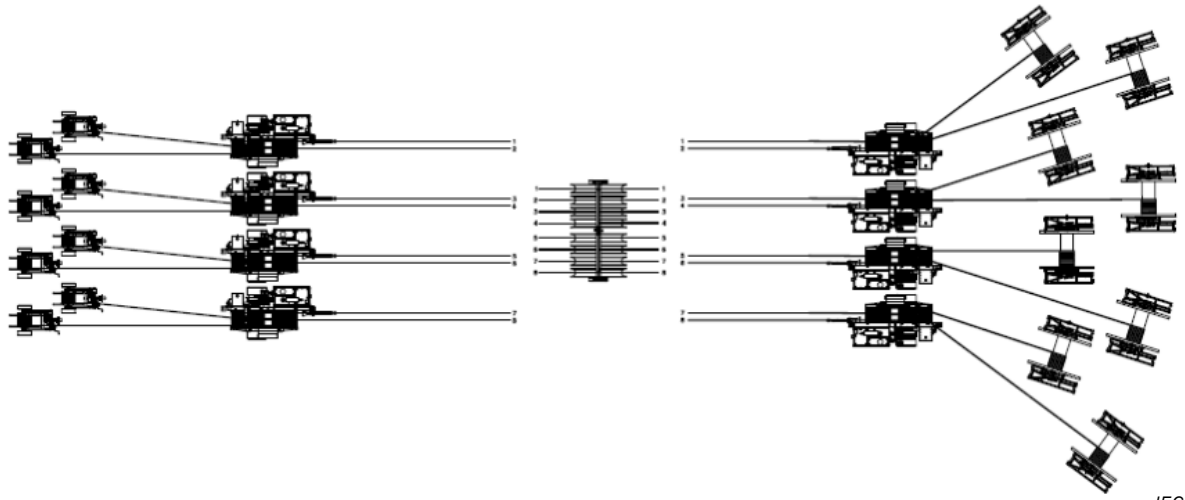
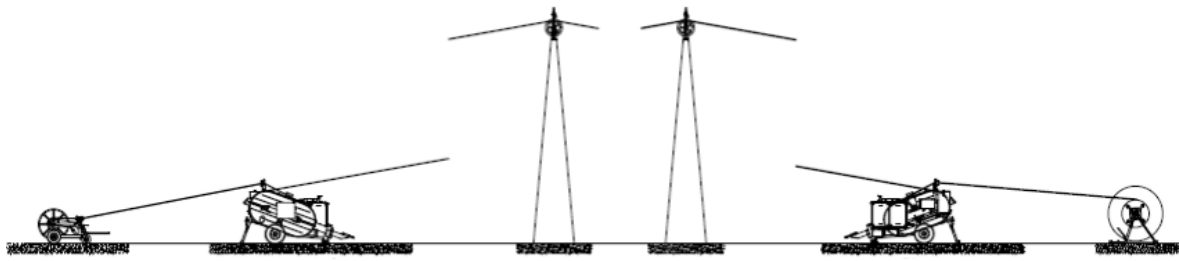

IEC

j) Transmission –  $n \times n$  stringing method

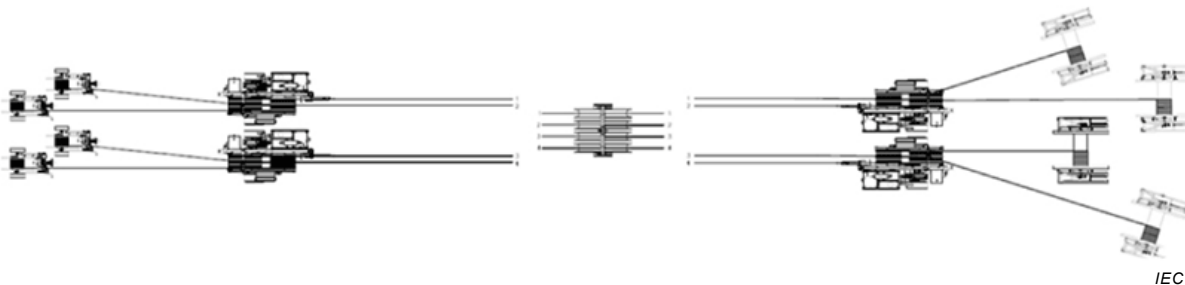
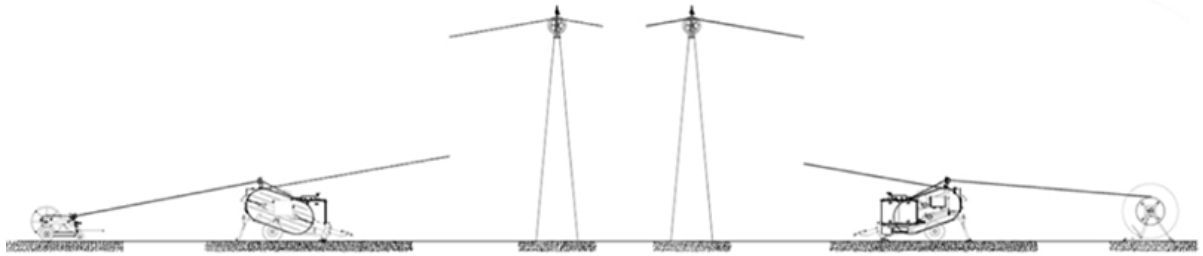

IEC

k) Transmission –  $n \times n$  reconductoring stringing method



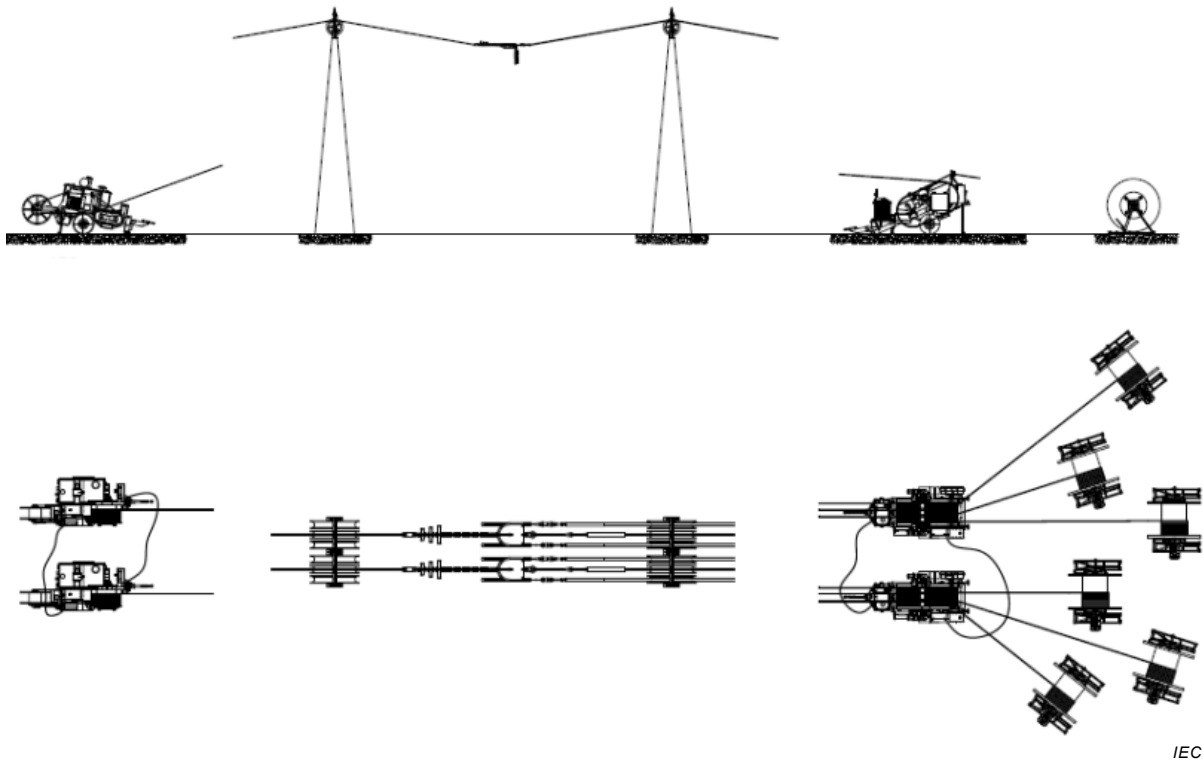

l) Transmission –  $2 \times (1 \times n)$  stringing method



m) Transmission – Reconductoring operation on double circuit power line with one circuit live

**Figure 6 – Tension stringing method**

## 5.4 Stringing equipment

### 5.4.1 General

Subclause 5.4 deals with the equipment used in the *tension stringing* method of installing *conductors*, and gives some general criteria for choosing these machines, including safety measures for protection of personnel from electrical hazards. The same basic criteria will also apply to this equipment used with the *slack stringing* method.

### 5.4.2 Tensioners

#### 5.4.2.1 Overview

For distribution *conductors*, where the tension used to string *conductors* is usually less than 5 kN, a drum type *tensioner* or *reel stand* is normally used. The *conductor* reel itself is inserted in the machine and the reel is retarded or braked to the *stringing* tension.

For distribution *conductors*, where the tension needed to string the *conductor* is more than 5 kN, and for transmission *conductors*, *tensioners* are usually *bullwheel* type.

There are two types of *bullwheel tensioners*:

- a) multigroove *tensioners* with two *bullwheels* having four or more grooves per *subconductor* on the *bullwheel* (see Figure 7a and 7b) — The number of grooves for each *subconductor* shall be sufficient to prevent the outer layer of wires of multilayer *conductors* from slipping over underlying layers. This is achieved by gradually increasing the tension on the *conductor* on the grooves of the *bullwheels* by using low friction materials instead of soft material, and it is extremely important for trapezoidal wire (TW) typology of *conductors* and new generation of high temperature low sag (HTLS) *conductors*. A minimum number of four grooves is required for aluminium conductor steel reinforced or traditional *conductors*, while for TW or HTLS *conductors* a minimum of six grooves is required. In case of some ACSR conductors and for TW and HTLS conductors, to avoid birdcaging, a higher number of grooves is recommended, in order to transfer the stress of the outer surface of the conductor to the core of the conductor. The total number of grooves to be used for each sub-conductor is also related to the maximum tension required.
- b) V-groove *tensioners* with one *bullwheel* having a single V-groove — Machines have been made with two or more *bullwheels* each having a single V-groove. Use of V-groove *tensioners* is not recommended for multilayer *conductors*, due to the fact that *birdcaging* of the *conductor* has a greater possibility of occurring because the stress on the *conductor* due to the tensioning process is transferred to the *conductor* over a shorter length than is the case with multigroove *bullwheels*

#### 5.4.2.2 General criteria

General and desirable characteristics that apply to *bullwheel tensioners* are the following.

- a) It is important that the *conductor* be installed smoothly without jerking or bouncing, to avoid any sudden overload on machines and equipment and grant a safe and quality *stringing*. Therefore fully hydraulic braked *tensioners* are recommended. The braking system should provide for a constant tension in the *conductor* at all *stringing* speeds and should hold this tension even when the pull is stopped. Mechanical braking of the *tensioner bullwheels* is not recommended because it gives a less smooth control of the tension than does full hydraulic braking.
- b) For multiconductor per phase (bundle) installations, all *subconductors* need to be installed at the same time and the same tension should be applied. The tensioning system needs to incorporate the ability to do this: a preferred procedure is to use machines with independent control of *bullwheels*, due to the better control of each tension line with respect to machines with single control of *bullwheels*. The *subconductors* in a bundle being installed together should preferably all be taken from the same manufacturer's production run or lot.

### 5.4.2.3 Choosing the correct capacity of the tensioner

*Tensioners* are usually rated by the maximum tension that can be accomplished for each *conductor* or *subconductor* in the case of a multiconductor *tensioner*.

The *tensioner* chosen for each project should have the capacity to tension the *conductor* with sufficient *clearance* from the ground between towers or other obstacles to be crossed. It is recommended to choose a *tensioner* with at least 15 % to 20 % overcapacity with respect to the expected maximum tension line estimated, to grant the ability to properly manage unexpected situations in which an extra tension may be required (see also 6.3.2.2).

### 5.4.2.4 Other criteria for the selection of tensioners

The following specific criteria should be considered in the correct choice of a tensioner to be used for a particular project.

- a) The *bullwheel* grooves are lined with a material which will prevent damage to the surface of the conductor and allow the conductor to set itself on the bottom of the groove, to avoid torsional stress that can generate birdcage damage. Material like polyamide or thermally and chemically treated steel are recommended, because they minimize the side friction effect, and are used in case of TW conductors or HTLS conductors.
- b) The minimum *bullwheel* diameter at bottom of groove is 35 times the conductor diameter.
- c) The minimum *bullwheel* groove diameter is 1,1 times the conductor diameter, to allow the mesh sock joint installed on the conductor's head to pass through the groove in the proper way.
- d) In case of *bullwheel* with soft lining material, such as adiprene or neoprene or similar, they should preferably provide for reeving and stringing the normal right-hand outer lay conductor. This means that, standing behind the tensioner looking toward the tower in the direction of stringing, the conductor should enter the tensioner *bullwheels* on the left, be wound on the *bullwheel* pair from left to right, and exit to the tower on the right. This will tend to tighten the outer layer of normal right-hand lay conductor as the conductor passes through the *bullwheels*.
- e) Mechanical connection between the two *bullwheels* of the same pair is suggested (gears are preferred – see Figure 7c), to avoid different speed of the two *bullwheels* of the same pair and consequent overstress of the conductor.
- f) It is recommended that the conductor be guided into the correct groove of the *bullwheel* linings from the conductor reel with fairlead sheaves or rollers placed below and on each side of the conductor. For TW or HTLS conductors, rollers should be designed in a way to minimize the conductor angle between reel-stand and tensioner side (see Figure 7d).
- g) Fairlead guiding rollers provided in front of the tensioner are not recommended because they act on the conductor under tension, and therefore should have at least the same diameter required for the stringing blocks (see 5.4.9.2)
- h) There shall be a holding brake incorporated in the drive train for each *bullwheel* pair, which is usually a hydraulic off spring applied type so as to hold the conductor at stringing tension in case of a drive train or hydraulic component failure. The operator shall also be able to apply and release the holding brake from the control console. In certain applications, such as per conductor stringing by helicopter to pull the conductor, a proper logic of safe operation of the holding brake shall be provided, to avoid a critical situation involving closure of the brake while tensioning.
- i) The tensioner control console should have a tension indicating gauge or gauges showing the tension in each conductor or *subconductor*.
- j) The tensioner control console should be located so that the operator has good visibility of the conductor reel and the stringing process. Remote operated controls can be used to allow a better vision of the working area, but the operator needs to remain at the same voltage potential as the tensioner machine, in case of an accidental electrical contact or where induction is occurring. Therefore a proper installation grid with equipotential area and proper earth connection has to be provided around the machine.

- k) The tensioner frame should incorporate adequately sized anchor lugs for attachment of ground anchors to hold the machine in place on the job site. Since tensioners are typically trailer mounted, and will move easily on wet or unstable ground, holding anchors are strictly required.
- l) The tensioner frame shall incorporate an earthing lug or bar, free of paint or other coating or surface contamination which would prevent a good electrical connection, specifically when attaching an earth clamp, and needs to be connected to the equipotential grid around the machine.
- m) If the tensioner has an operator's cab, engine or other component with rubber mounts to isolate noise or vibration, then an earthing strap shall be installed from the isolated component to the frame.
- n) The operator's ability to clearly hear work instructions while the tensioner is operating is important. A suitable communication system with ability to communicate clearly with the puller operator and other persons participating in the stringing process shall be provided.
- o) In case of larger *bullwheel* diameter machines and/or larger operating tension value, the dimension of the tensioner machines should become larger and heavy. Therefore, a modular design is recommended to allow the machine to be separated in single parts (see Figure 7e), especially where transportation and assembling of the units is made by helicopter.



IEC

a) Multigroove tensioners with one pair of bullwheels



IEC

b) Multigroove tensioners with multiple pairs of bullwheels

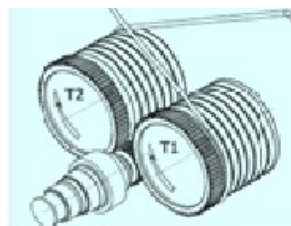

IEC

c) Mechanical connection between the two bullwheels of the same pair



d) Minimizing angle fairled



e) "Modular" tensioner

Figure 7 – Bullwheel tensioners

### 5.4.3 Pullers

#### 5.4.3.1 Overview

Four basic types of *conductor pullers* exist:

- a) *drum pullers*, with either single drum, or one for each rope to be pulled (see Figure 8a);
- b) *bullwheel pullers* with separate *reel winder* (see Figure 8b);
- c) *bullwheel pullers* with integral *reel winder* (see Figure 8c);
- d) *puller-tensioners* (see Figure 8d).

The first three types are designed to primarily act as *pullers* only for the *pulling rope* or *pulling rope*.

*Puller-tensioners* can be either of the drum type, which are normally used just for work on distribution lines with limited distance to be covered, or of the *bullwheel* type for work on both distribution and transmission lines, in particular for reconductoring operation.

*Puller-tensioners* can act as *pullers* for a *pulling rope* and, acting at the other end of the *pull section*, the same machine can be used to tension out the *conductor* as a *tensioner*. When acting on a reconductoring job, the *puller-tensioner* can also recover the old *conductor* that is used as a pulling element to string the new *conductor*.

Usually the diameter of the *bullwheels* for a *puller-tensioner* is larger than that of a *puller* only, and the *bullwheels* for a *puller-tensioner* will have the grooves lined with a material which will prevent damage to the surface of the *conductor*, since this machine may also be used for the tensioning of the *conductor* (see 5.4.2.4 a).

#### 5.4.3.2 General criteria

General and desirable characteristics that apply to *pullers* are the following.

- a) It is important that the *conductor* be pulled smoothly without jerking or bouncing. Therefore, *puller* speed changes should be smooth.
- b) The *puller* shall have sufficient pulling power to start the *conductor* moving at full *stringing* tension after a stop.

#### 5.4.3.3 Choosing the correct capacity of puller

Drum *pullers* are usually rated by output torque. This output torque rating should be converted to maximum linepull at the diameter of the *pulling rope* on the drum when the drum is fully wound with the rope.

*Bullwheel pullers* are usually rated according to the maximum linepull that can be accomplished at a lower *stringing* speed, normally rated at approximately 2,5 km/h, while the maximum operating speed is normally rated at approximately 5 km/h.

The *puller* size chosen for any particular project shall take into account the *stringing* tension per *conductor* and the number of *conductors* per phase to be pulled at one time, which determine the total *stringing* tension value, and the length and the path of the *pull section*, which determine how much the total tension value has to be incremented to be able to pull the line. It is recommended to choose a *puller* with at least 20 % to 25 % overcapacity with respect to the expected pulling line, to grant the ability to properly manage unexpected overload on the line that may arise for any reason (see also 6.3.2.2).

#### 5.4.3.4 Other criteria for the selection of pullers

Other criteria for the selection of *pullers* are as follows.

- a) The *puller bullwheels* should have hardened steel grooves for maximum wear characteristics if the *puller* is to be used with steel *pulling rope*. *Connector links* which have bigger size than the *pulling rope*, when passing through the *bullwheel* grooves will induce a much higher tension in the *pulling rope*: the groove geometry and the material treatment should support and minimize the overload effect.
- b) For the *puller-tensioner*, *bullwheel* material like thermally and chemically treated steel is the best solution, because they minimize the side friction effect when *stringing conductor* and grant wear resistance characteristic when *stringing* steel rope. An alternative solution is polyamide, as per the *tensioner bullwheels*.
- c) The diameter of the *puller bullwheels* is not as important as that of the *tensioner*. However, it is not recommended to use a *puller* with *bullwheel* diameter less than 25 times the rope diameter for a steel *pulling rope* or 20 times the rope diameter for synthetic ropes; smaller diameters will reduce the working life of the *pulling rope*. With some types of steel *pulling ropes*, a larger ratio of rope to *bullwheel* diameter may be desirable, and the manufacturer of the rope should be consulted.

A *puller-tensioner* to be used in reconductoring operation to pull out the old *conductor*, which is used as a *pulling rope* to pull in the new *conductor*, should have a *bullwheel* diameter of at least 35 times the *conductor* diameter, as per the *tensioner* design, or higher, considering that the old *conductor* condition and behaviour is not really predictable. Smaller diameters will increment the stress on the old *conductor* being pulled and could create issue in case of undisclosed defects.

- d) It is required that the *bullwheel* drive system be provided with mechanical connection between the two *bullwheels* of the same pair (gears are preferred – see Figure 7c), to avoid different speeds of the two *bullwheels* of the same pair and consequent overstress of the rope or *conductor*.
- e) A holding brake is incorporated in the *puller* drive train. This can be a hydraulic off spring applied type so as to hold the *pulling rope* at *stringing* tension in case of a drive train failure, or during a normal stop sequence. The operator shall also be able to apply and release the holding brake from the control console.
- f) The *puller* control console should preferably have a linepull indicating gauge including an overload device, which can be preset by the operator to a maximum pulling value. *Pullers*



fitted with an overload device shall automatically stop when this level of linepull is reached. This will prevent the *puller* from continuing to pull up to dangerous levels if the *conductor*, rope or *running board* become snagged and held somewhere along the *pull section*. A double overload system is recommended and the second one can be achieved by hydraulic or electronic control of the unit.

- g) The controls for the *reel winder* should be incorporated in the control console of the *puller* for *bullwheel* type *pullers*. This will give the *puller* operator full control of the *pulling rope* winding operation.
- h) The *pulling rope* should be guided into the correct groove of the *bullwheel* from the *reel winder* with fairlead sheaves or rollers placed below and on each side of the *pulling rope*. Similar fairlead rollers should be used to guide the *pulling rope* between the *bullwheels* and the *structure* if the working angle does not allow the rope to self-guide into the proper groove of the *bullwheels*.

For drum type *pullers*, a level winder is recommended to ensure that the *pulling rope* is guided from the *structure* to the *pulling rope* drum, and evenly wound across the width of the drum. This makes for smooth pulling and eliminates tangles with the rope on the drum.

- i) The *puller* control console should have a tension indicating gauge or gauges showing the tension in the *pulling rope*.
- j) The *puller* control console should be located so that the operator has good visibility of the *reel winder* and the *stringing* process.
- k) Remote operated controls can be used to allow a better vision of the working area, but the operator needs to remain at the same voltage potential as the *puller* machine, in case of an accidental electrical contact or where induction is occurring. Therefore a proper installation grid with *equipotential* area and proper *earth* connection has to be provided around the machine.
- l) The *puller* frame incorporates adequately sized *anchor* lugs for attachment of *earth anchors* to hold the machine in place on the job site. Since *pullers* are typically trailer mounted, and will move easily on wet or unstable earth, holding *anchors* are required.
- m) The *puller* frame incorporates an earthing lug or bar, free of paint or other coating or surface contamination which would prevent a good electrical connection, specifically when attaching an *earth clamp*.
- n) If the *puller* has an operator's cab, engine or other component with rubber mounts to isolate noise or vibration, then an earthing strap shall be installed from the *isolated* component to the frame.
- o) The operator's ability to clearly hear work instructions while the *puller* is operating is important. A suitable communication system with ability to communicate clearly with the *tensioner* operator and other persons participating in the *stringing* process shall be provided.
- p) In case of larger *bullwheel* diameter machines and/or larger operating tension value, the dimension of the *tensioner* machines should become larger to avoid easy transportation and movement. Therefore, a modular design is recommended to allow the machine to be separated in single parts.
- q) The same concept applies to machines that need to be used in areas that cannot be reached with traditional road transportation methods. The units have to be transported by helicopter, detached in separate elements respecting the working load of the helicopter being used, and provided with proper devices to be reassembled by using the same helicopter as a working crane (see Figure 8e).



IEC

a) Drum puller, two single drums (IEC 60743)



IEC

b) Bullwheel puller (puller-tensioner) with separate reel winder

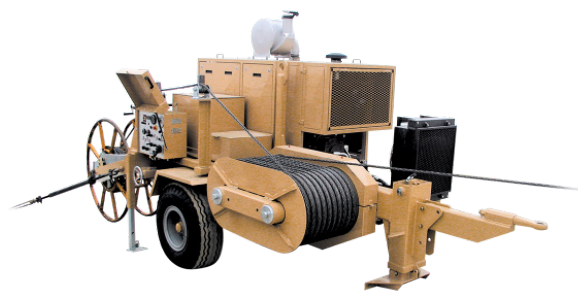

IEC

c) Bullwheel puller with integral reel winder (IEC 60743)





IEC

d) Puller-tensioner



IEC

e) "Detachable" puller

Figure 8 – Bullwheel pullers

#### 5.4.4 Reel winders

##### 5.4.4.1 Overview

*Reel winders* are used to wind up a *pulling rope* behind *bullwheel pullers*. They are not required for drum *pullers*.

*Reel winders* are usually incorporated on the same frame as the *bullwheel pullers*, but sometimes, for larger *pullers*, the *reel winder* is a completely separate machine to reduce the overall weight of each component.

They can have their own power source for driving the rope drum, or more frequently they may be powered from a hydraulic drive on the *puller* by means of hydraulic hose connections.

In any case, they are always driven so that they tend to wind up the *pulling rope* faster than the *puller* is able to feed the rope to the *reel winder*. This ensures that the *pulling rope* always remains taut between the *puller* and the *reel winder* so that the rope does not loosen on the *puller bullwheels*.

#### 5.4.4.2 Criteria for choosing reel winders

The criteria for choosing *reel winders* are as follows.

- a) *Reel winders* have a levelwind system to help to wind the *pulling rope* evenly across the rope drum and prevent uneven build-up that could cause snarling of the rope on the drum.
- b) The *reel winder* should be able to accommodate the size and weight of the *pulling rope* drum to be used on the project. Normally the rope lengths to be used on the project are multiple, and therefore the reel is changed when full of rope and replaced with a new one empty; in this case the *pulling rope* is provided with proper connector to detach or connect between the single section lengths. Larger reels will reduce or eliminate the need to change reel every section or rope, but will increase the overall weight of the *reel winder*.
- c) The *reel winder* circuit is normally arranged to allow the *stringing* process when the *pulling rope* is being installed from the *puller* end to the *tensioner* end of the *pull section*, to prevent the rope drum from continuing to turn when the rope pulling operation has stopped. In some case the take-up drive can be disconnected, and this requires an overspin mechanical brake on the transmission.
- d) There shall be a holding brake or reverse motion brake incorporated in the *reel winder* drive train so as to hold the *pulling rope* at normal tension between the *reel winder* and the *puller bullwheels* in case of a drive train failure, or during a normal stop sequence.
- e) If the *reel winder* is not an integral part of the *puller*, the *reel winder* frame should incorporate adequately sized *anchor* lugs for attachment of *anchors* to hold the machine in place on the job site. Since separate *reel winders* are typically trailer mounted, and will move easily on wet or unstable earth, holding *anchors* are strictly required.
- f) If the *reel winder* is not an integral part of the *puller*, the *reel winder* frame shall incorporate an earthing lug or bar, free of paint or other coating or surface contamination which would prevent a good electrical connection, specifically when attaching an *earth clamp*.

#### 5.4.5 Reel stands

##### 5.4.5.1 General

*Reel stands* are used to hold the *conductor* reels. They are usually positioned behind the *tensioner*, and used to wind off the *conductor* from the reel as it is fed to the *tensioner*. They can be self-loading, and therefore called reel-elevators, but usually the reels are loaded into the *reel stands* by crane, or other lifting means.

One *reel stand* is required for each *subconductor* of the phase.

For distribution lines *reel stands* or reel carriers are used to hold the *conductor* reels. They can be used to directly tension the distribution *conductor* when such *conductors* are very small (less than 13 mm) and there is no possibility of contact between the new *conductor* being installed and existing *energized conductors*.

*Reel stands* are rarely incorporated on the same frame as the *tensioner*, but usually only for single *conductor tensioners*.

The *reel stand* will require a brake to hold a tension in the *conductor* between the *reel stand* and the *tensioner*. This brake should be of sufficient size to hold this tension at normal *stringing* speeds until the reel has been emptied of *conductor*. Hydraulic braking systems are preferred in order to reduce jerking or bouncing at the *conductor*, and normally the drive system is fed directly by the *tensioner* machine.

#### 5.4.5.2 Criteria for choosing reel stands

Criteria for choosing *reel stands* are as follows.

- a) The *reel stand* shall be able to accommodate the size and weight of the *conductor reel* to be used on the project.
- b) The *reel stand* frame should incorporate adequately sized *anchor* lugs for attachment of earth *anchors* to hold the machine in place on the job site. *Anchor* lugs and *anchors* are especially required if the *reel stands* are trailer mounted, since wheeled trailers will move easily on wet or unstable earth.
- c) The *reel stand* frame shall incorporate an earthing lug or bar, free of paint or other coating or surface contamination which would prevent a good electrical connection, specifically when attaching an *earth clamp*.

#### 5.4.6 Pilot rope puller

*Pilot rope pullers* will have essentially the same characteristics as those of a *conductor puller* (see 5.4.3). They are used on the larger transmission line construction projects to pull the *pulling rope* from the *puller* end to the *tensioner* end of the *pull section*.

*Pilot rope pullers* used to construct distribution lines are usually the removable drum type, and sometimes they are powered from the *tensioner* or *puller-tensioner*.

*Pilot rope pullers* are rarely used to pull in the *earth wire*, while they cannot be used to pull in the optical ground wire (OPGW), which needs a dedicated *tensioner*.

#### 5.4.7 Pilot rope, pulling rope

A *pulling rope* for transmission line work is usually a high strength steel wire rope specially constructed for this purpose. High strength synthetic ropes have been used for this purpose, but usually only for pulling single *conductor* per phase.

A *pilot rope* can be either a steel wire rope or a high strength synthetic rope.

*Pilot ropes* and *pulling ropes* for distribution line work are usually high strength synthetic ropes, specially constructed for this purpose. Each *pilot rope* should be a different colour for each phase plus neutral (if used), so that the *pilot rope* is always put in the same phase *stringing block* during installation.

One of the most important characteristics of a pilot or *pulling rope* is its non-twisting capability, especially since the rope is stretched over long distances when used. The rope should not impart twist or spin to the *conductor* or the *running board*.

Steel ropes are normally made by several independent strands braided between them to reach the non-twisting capacity; the number of individual strands is 8 or 12, in some large ropes even up to 18 strands. The material is normally high-resistance steel grade with the capacity to withstand fatigue effect related to the use on the multiple *bullwheel* grooves.

The rope manufacturing process needs to implement the capacity to grant the equal distribution of the stress in all the individual strands, to avoid dangerous overload and bad behaviour of the rope under load.

The rope (particularly for steel ropes) should have a smooth outer surface to minimize vibration and wear as the rope passes around *bullwheels* and over *stringing blocks*.

Steel *pulling rope* is normally pre-greased when manufactured; the *puller* machines need to grant the proper gripping effect by providing a sufficient number of grooves and proper control of the *reel winder*. Steel *pulling rope* dry or with no grease can grant a better gripping on the

*bullwheels* of the *puller*, but it will generate a serious decrease of the working life of the rope due to fatigue damage.

Where synthetic ropes are used as pulling or *pilot ropes*, they should not be considered as insulating. They may initially present a high resistance electrical path, but experience has shown that over time and with use the surface of the synthetic rope becomes sufficiently contaminated to be conductive, particularly in wet conditions.

The use of synthetic ropes is becoming popular, but it requires particular care in handling and operating the rope on the job site, because the rope can be easily damaged, and therefore can create a situation of danger in case of unexpected breaking.

Synthetic ropes used as pulling or *pilot ropes* should be chosen to have a stretch or elongation equivalent to that of the steel ropes, therefore not exceeding 3 % at the rope breaking strength; common practice is to calculate the elongation from a load applied equal to 4 % of the supposed breaking load, to allow the self-adjusting effect of the structure of the rope. Excessive stretch means the rope stores considerable elastic energy which can be dangerous in case of rope breakage, can damage the *bullwheel structure* due to the release of the elastic energy involved and requires heavy storage reels to resist the crushing forces resulting from this elastic energy.

The recommended *factor of safety* for pulling and *pilot ropes* is as follows.

- Steel ropes: the rope breaking strength shall be not less than three times the expected maximum working load.
- Synthetic ropes: the rope breaking strength shall not be less than five times the expected maximum working load. Some high strength synthetic ropes have been used successfully at a breaking strength of four times the expected maximum working load, but the manufacturer should specifically approve the maximum working load on these ropes.

NOTE In some jurisdictions, safety codes may require a working load to breaking strength ratio higher than the above values.

Normally the *pulling ropes* are provided with spliced eyes at each side of the section, to allow the connection of multiple sections by using the proper links (*fixed joints*) or to allow the connection of the proper *swivel* joint in front of the head section connected to the single *conductor* or to the headboard. The breaking strength to be considered is intended with presence of the spliced eyes, and the rope manufacturer shall declare this data in the technical specification.

#### 5.4.8 Woven wire grip

It is important to select the *woven wire grip* according to the type of the *conductor*.

The working load of the *woven wire grip* shall be calculated to fulfil the breakdown of the outer layer of the *conductor*; in case of doubt, preliminary tests are recommended.

Using long *woven wire grip*, the value of the breakdown should be extended to whole *conductor* capacity and be bigger.

#### 5.4.9 Stringing blocks

##### 5.4.9.1 Overview

*Stringing blocks* are hung on each tower, usually at the end of each phase insulator string and at the *earth wire* position. They are used to position and pass the *conductor* as it is being strung.

On heavy angle towers, the *stringing block* may be hung directly from the towerbridge or crossarm. In this case, if the *stringing block* has a lined *conductor* sheave, it is

recommended that the *stringing block* be isolated from the tower *structure* with an insulating link, or use a *stringing block earth*.

To allow the *conductor* to be always sat on the bottom of the groove of the wheels, in the correct position for *stringing* operation, the *stringing blocks* need to be suspended in a way that they can self-adjust the working position. On heavy angle towers, the *stringing blocks* should be tied up to the tower *structure* such that they hang at the normal swing angle which they will assume when they come under load from the *pulling rope*, or the *conductor*. During *stringing* operation this position can change while passing from *pulling rope* to *conductors*, so the tied-up position should be further adjusted.

*Stringing blocks* for distribution *conductor* usually have an unlined sheave with a smooth groove surface to protect against damage to the *conductor*. *Blocks* with an elastomer lining are also used.

*Stringing blocks* for transmission are normally made by casting wheel with *conductor* sheave linings. Single casting *blocks* are preferred to composed casting *blocks*, due to a better stability and mechanical behaviour under load.

*Conductor* sheave linings are used to protect the surface of the *conductor* from scratches or other damage as the *conductor* moves through the *stringing block*. Linings may be of rubber, polychloroprene, polyurethane or other elastomer, polyamide or aluminium, normally applied on the bottom of the groove (see Figure 9a, 9b and 9c). Polyamide or aluminium lining provides better treatment on the outer layer of the *conductor* due to the reduced friction, which allows the *conductor* to easily self-adjust on the bottom of the groove, where the *conductor* is supposed to work in any *stringing* configuration.

Polyurethane, polyamide or aluminium lining need to be used where both the *pulling rope* and the *conductor* will pass through the same sheave, such as on single *conductor stringing blocks* or for the *pulling rope* sheave on odd number *subconductors* per phase *stringing blocks* (e.g. three *subconductors* per phase). Rarely, for transmission lines with more than one *conductor* per phase, *stringing blocks* consist of a pulling rope sheave which may be unlined, and lined *conductor* sheaves – one for each *subconductor*.

The sheave lining material should not be considered as conductive even if it contains a conductive element. Experience has shown that so-called conductive linings become essentially non-conductive after a period of use. An exception is represented by aluminium lining or unlined sheaves, which can be considered fully conductive.

It is recommended that the *stringing block* sheaves be provided with high quality roller or ball bearings to minimize the rolling and frictional resistance of the block during *stringing*. The bearings should be either of the sealed type, greased by the manufacturer, or regreaseable by means of a grease fitting.

The load rating specified by the manufacturer for the *stringing block* shall not be exceeded. Special care shall be taken with the *stringing blocks* used on angle towers to ensure they are not overloaded in the *sagging* operation; these *blocks* are usually chosen with a larger load rating and a larger sheave diameter. In some cases more than one *stringing block* is used in a tandem block application on heavy load towers, to better distribute the load on each wheel (see Figure 9d).

To allow installation of *pilot rope* by helicopter, *stringing blocks* can be designed with open frame design and proper finger guides, to automatically position the rope on the central wheel and to ensure the correct positioning of the rope during *stringing* operations (see Figure 9e).

#### **5.4.9.2 Criteria for choosing stringing blocks**

Criteria for choosing *stringing blocks* are as follows.

- a) For best results during the *stringing* and sagging operations, the minimum diameter at the bottom of each *conductor* sheave groove (sometimes called root diameter) should be:

$$D_s = 20 D_c$$

where  $D_s$  and  $D_c$  are in millimetres and  $D_c$  is the diameter of the *conductor* to be installed.

On *stringing blocks* located on the angle *structures* with more than 30° breakover angle and on the *structures* in front of the *puller* and *tensioner*, due to the loads imposed, larger diameter *blocks* or tandem solution shall be used.

NOTE 1 *Conductor* manufacturers may require a different ratio for specific *conductors*, such as TW or HTLS.

NOTE 2 The above ratio may be different as required by some countries, codes.

- b) The minimum depth of the sheave groove should be:

$$D_g = 1,25 D_c$$

- c) The minimum groove radius at the bottom of the groove should be:

$$\frac{1,1 D_c}{2}$$

The groove profile and the groove radius should be wide enough to allow passage of *conductor swivels* and *woven wire grips* without these riding high in the groove and imparting a shock load to the sheave. It is important also to consider the shape of the sheave groove if it is desired to make *conductor* mid-span joints in front of the *tensioner* and pass these through the *stringing blocks* by using *cover joint protector*. The *joint protector* usually has split rubber collars or cones at each end to protect the *conductor* from damage where it exits at the end of the sleeve. In this case a wide sheave groove should be considered. For safety reasons, it is not possible to let the mid-span joint pass through *blocks* without *cover joint protector*.

- d) The sides of the groove should allow the passage of *swivels*, *conductor compression joints*, *conductor woven wire grips*, mid-span joint with cover joint, etc. without creating jerking or bumping effect. Side grooves normally flare 3° to 5° from the vertical when sheave linings are applied on the bottom of the groove, and the grooves are designed to allow mid-span joint to pass through the *blocks* by using *cover joint protector*.
- e) The *stringing block* frame should allow for opening of the top or side for easy removal of the *conductors* during the *clipping-in* operation.
- f) The throat of the *stringing block*, or the area where the *conductor* passes through, should be designed to allow for the smooth passage of a *running board* in the case of bundle *blocks*, or *conductor* mid-span joints, *swivels*, *pulling rope eyes*, etc. All these items cannot make any contact with the block frame.

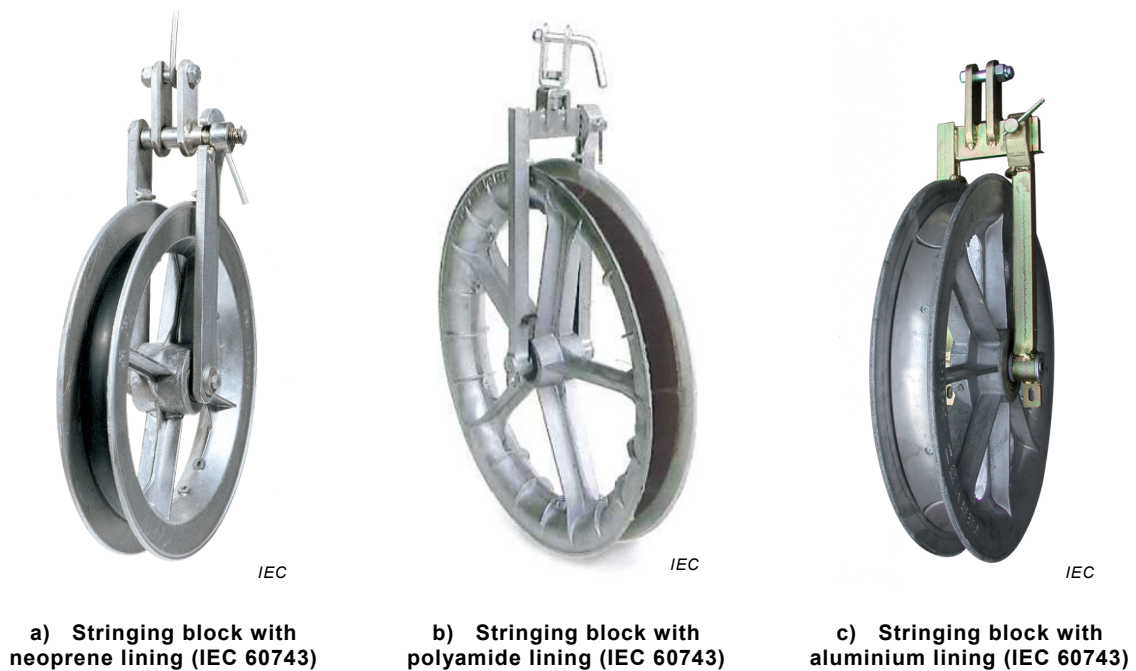

Figure 9 – Stringing blocks

#### 5.4.10 Stringing rollers

*Stringing* rollers are a possible alternative to the traditional *stringing blocks*, in particular when large radius is required.

They are made by a series of rollers, placed on an equivalent radius equal to the expected diameter of a *stringing block*, arranged with self-orientation possibility, to reach the required configuration when *stringing* (see Figure 10a and 10b).

Material of rollers and lining should be as per the traditional *stringing blocks*. Anyway particular care is needed due to the highest rotation speed of the rollers and the involved wear of the linings; hard linings such as polyamide or metallic are recommended.

The groove profile and the groove radius should be wide enough to allow passage of *conductor swivels* and *woven wire grips* without these riding high in the groove and imparting



a shock load to the rollers. It is important also to consider the shape of the sheave groove if it is desired to make *conductor* mid-span joints in front of the *tensioner* and pass these through the *stringing* rollers by using cover *joint protector*. In this case a wide sheave groove should be considered.

The *stringing* rollers frame should allow for opening of the top or side for easy removal of the *conductors* during the *clipping-in* operation.

The throat of the *stringing* rollers, or the area where the *conductor* passes through, should be designed to allow for the smooth passage of a *running board* in the case of bundle rollers, or *conductor* mid-span joints, *swivels*, *pulling rope eyes*, etc. All these items cannot make any contact with the rollers frame.



IEC

a) Stringing rollers for single conductor



IEC

b) Stringing rollers for bundle conductor

**Figure 10 – Stringing rollers**

#### 5.4.11 Stringing block earth

*Stringing block earths* are attached to the *stringing block*, and are placed on moving *conductors* or *pulling/pilot ropes* and used to provide an electrical path to earth. They are primarily used to provide safety for personnel during construction or reconstruction operations. This device is placed on the *stringing block* at a strategic location where an electrical earth is required.

Some important characteristics of a *stringing block earth* are the following.

- a) It shall be capable of withstanding a current of 20 000 A symmetrical for 20 cycles.
- b) It shall have an earthing bar, free of paint or other coating or surface contamination which would prevent a good electrical connection, specifically when attaching an *earthing cable* with *earth clamp* (see Figure 12f in 6.2).



- c) *Compression joints*, woven wire mesh joints with *swivels*, or rope joints shall pass through or over the *stringing block earth* easily. The *stringing block earth* shall be held tightly on the rope or *conductor*.
- d) The sheaves are normally of aluminium for the part of the earth contacting the *conductor*, and of hardened steel for the part of the earth contacting the steel pulling/*pilot rope*.

*Blocks* arranged with aluminium casting groove or aluminium lining sector are considered integrally conductive, so they should not need an external earth system, depending on the earthing level required (see also 6.2.9).

#### 5.4.12 Running earth

Running earths are placed on moving *conductors* or pulling/*pilot ropes* and used to provide an electrical path to earth. They are normally used at the pull and *tension sites*.

Some important characteristics of a running earth include the following.

- a) It shall be capable of withstanding a current of 20 000 A symmetrical for 20 cycles.
- b) It shall have an earthing bar, free of paint or other coating or surface contamination which would prevent a good electrical connection, specifically when attaching an *earthing cable* with an *earth clamp* (see Figure 12b in 6.2).
- c) It shall be of such a design that *conductor* compression joints, woven wire mesh joints with *swivels*, or rope joints will pass through the running earth without having to be removed from the *conductor* or rope. The running earth shall be held tightly on the rope or *conductor*.
- d) The sheaves are normally of aluminium for running earths used on *conductors*, and of hardened steel for running earths used on steel pulling/*pilot rope*.
- e) The running earth shall have an attachment point for an *anchor* rope which will hold the earth stationary while the *conductor* or rope moves through it. The earthing cable shall never be used as an *anchor*.

#### 5.4.13 Hold-down block

As the *pilot rope* is much lighter than the *conductor(s)*, during the *stringing* an uplift could occur at some towers. The *hold-down block* is used to maintain the *pilot rope* inside the sheaves of the *stringing block* of the tower.

The *hold-down block* has an attachment hook or shackle to hold it down and generally a device allowing to take it off during the *stringing* without necessity to climb up the tower.

#### 5.4.14 Conductor car

##### 5.4.14.1 Overview

A *conductor car* is a special cage or device designed to carry one or more workmen and ride on a single or bundle *conductor* to inspect these *conductors* or, more normally, to install spacers, spacer dampers, or other attachments, where required.

*Conductor cars* are used also as a live line tool for maintenance of *conductors*.

*Conductor cars* are constructed in three basic types.

- a) Non-powered *conductor cars* consist of a cage hanging from wheel supports on the *conductor*, with no engine means of propulsion. The *conductor car* is either pulled along the *conductor* by the car operator, or towed from the ground by means of a synthetic rope attached to the *conductor car*. This kind of *conductor car* can be made with two axles (see Figure 11a), available just for the spacer installation operations, or with four axles (see Figure 11b), available also for inspection on existing power lines; this car has the

ability to move past spacers by having always at least three axles in contact with the *conductor bundle*, allowing the operator to remain in the car.

- b) Manual powered *conductor cars* can be constructed in a form similar to a bicycle (see Figure 11c). The *conductor car* is suspended below the *conductors* from wheel supports. These wheels get their propulsive force from a mechanical transmission and pedal type drive. The operator faces rearward so he can install spacers from his pedalling position.
- c) Powered *conductor cars* consist of a cage hanging from wheel supports on the *conductor*, with an engine as means of propulsion. Normally, powered *conductor cars* are designed with a four-axle configuration (see Figure 11d) to be able to move around the *conductor* support clamp on the end of the insulator or past spacers, having always at least three axles in contact with the *conductor bundle*, allowing the operator to remain in the car.



IEC

a) Non-powered two-axle type conductor car



IEC

b) Non-powered four-axle type conductor car



IEC

c) Bicycle-type conductor car

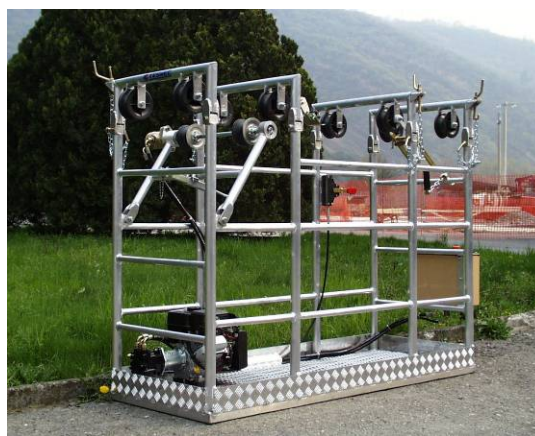

IEC

d) Powered four-axle type conductor car

Figure 11 – Conductor cars

#### 5.4.14.2 General criteria

The wheels on a *conductor car* serve three purposes:

- 1) they provide support on the *conductor* for the operator and cage hanging below;
- 2) some of the wheels will provide tractive power or propulsion for powered *conductor cars*;

- 3) along with idler wheels they will provide the correct *spacing* of bundle *conductors* so that the spacer can be installed easily.

The wheels, or the wheels and their supports, are usually designed to swing away from the *conductor* to assist in placing the car on the *conductor* initially, or to allow the car to be passed around insulator supports.

For powered *conductor cars*, drive wheels should be lined with an elastomer which will provide the necessary friction to drive the car and also protect the surface of the *conductor* from damage. The wheel lining should not be considered as an earthing path, since elastomer will usually have a high resistance to the passage of electricity.

Non-powered *conductor cars* and those specifically to be used for live working will usually have unlined support wheels.

The groove of the wheels should be such that the *conductor* will tend to track in the centre of the wheel, with adequate *clearance* at the sides to prevent pinching of the *conductor* in the groove, and to allow it to pass easily over *conductor compression joints*.

A powered *conductor car* should be designed to climb slopes of up to 30° with adequate additional safety against slipping backward under all conditions, wet *conductor* included.

Powered *conductor cars* usually have a gasoline engine for motive power. Therefore, extreme care shall be taken in the handling of fuel for the engine. Diesel engines have been used, but only rarely because of their weight disadvantage.

It is recommended that power from the engine be transmitted to the drive wheels or other mechanisms by means of a hydraulic system. This eliminates open chains, gears, or belts in the drive train.

The control lever for powered *conductor cars* should be of the “fail safe” type, returning to the neutral/stop position if released.

The engine should be located in such a way that the operator cannot easily contact hot engine parts or rotating parts, but still have reasonable access to a pull start rope and the fuel tank.

The control console of a powered *conductor car* shall have a large, visible panic button which will shut off the engine.

Hydraulic and engine controls (throttle) should be located in an easily accessible position for the operator. *Conductor cars* are usually designed to work on one configuration (number of *conductors* per phase) and *conductor spacing* only. The use of the *conductor car* on any other configuration than that for which it has been designed is not recommended without prior authorization from the manufacturer. Some car designs have the ability to adjust to different *conductor spacings* and numbers of *conductors* per phase.

Electrical drives are becoming popular, but it is recommended that the battery life be sufficient for a realistic working interval. A safe release system is provided to move the car in case of loss of power in midspan.

The weight of the *conductor car* is very important, particularly if the *conductor car* is to be used for live working. When the car is loaded with operator and material to be used for the work, the car should not pull the *conductor* so low that inadequate *clearance* to *energized* lines or guard *structures* (rider poles) crossing under the *conductor* being worked on will result. The same holds true for crossing over roads, rail lines, etc.

In addition, particularly if the *conductor car* has to be manually lifted around insulator supports, lightness will be desirable. So it is important that the *conductor car* be light, yet strong, and have good carrying capacity.

The design of the *conductor car* should take into account the weight of the operator, or operators, tools, and materials to be carried. Also, if a tow rope is to be used, the design should take into account the downward component of the tow rope forces.

A load capacity plate with “not to exceed” rating shall be attached to the *conductor car* frame in a conspicuous location.

All *conductor cars* should have a manually operated holding brake, which will clamp directly on the *conductor*, and two locking devices independent from each other. The brake can also work as a locking device.

For accurate positioning in the span of spacers or spacer/dampers, a resettable distance counter with drive wheel contacting the *conductor* is recommended.

*Conductor cars* should have lifting attachments at suitable points on the frame to allow ropes or slings to be attached when the car is to be lifted and placed on the *conductor*.

The *conductor car* should have at least one safety rope with each end connected to the car frame at adequate *anchor* points, and long enough to be looped over the *conductor(s)*. The rope will keep the car suspended should it come off the *conductor(s)*. Larger powered *conductor cars* should have two safety ropes, one at each end of the car.

Each safety rope should be strong enough to hold the weight of the operator, the tools and the car, with a *working load limit* of one tenth of the rope breaking strength.

The safety rope should have safety snap hooks at least on one end for easy removal from an *anchor* point.

The operator of the *conductor car* should loop his fall protection line over the *conductor(s)* while riding in the car. Bicycle type *conductor cars* should also have a safety belt system attached to the frame which will hold the operator in position on the seat.

The cage on non-bicycle-type *conductor cars* is usually constructed of an aluminium frame with a heavy duty wire mesh floor, and a wire mesh or solid aluminium sheet kick board all around the base at least 12 cm high to prevent loss of tools, etc.

It is recommended that powered *conductor cars* have a small multi-purpose fire extinguisher and an approved first aid kit located in an easily accessible position.

*Conductor cars* with lined wheels should also have an induction bonding wheel which will be an all aluminium wheel contacting one of the *conductors* and with a low electrical resistance path to the car frame.

It is recommended that *conductor car* operators be equipped with a radio-communication system, particularly for work on long span crossings over water, in mountainous areas, etc. where the operator may at times be out of sight of ground personnel.

It is recommended that the car have a clean and dry rope made of an insulating material, of such length as to reach the ground so that equipment can be lifted to the car and to allow the operator to rappel to ground level from the car in case of emergency. Such rope should be attached to the car with an insulating link. The rope will have a *working load limit* of one tenth of the rope's breaking strength to accommodate the lifted loads anticipated.

NOTE General criteria for *conductor car* are provided in EN 50374.

#### 5.4.14.3 Conductor cars for live working

*Conductor cars* used as a maintenance tool for live working deserve special mention. These *conductor cars* will generally conform to the above requirements except in the following areas.

- a) All parts of the car shall be manufactured from a conductive or non-conductive material.
- b) Light weight is extremely important for *conductor cars* used in this application to ensure the conductor is not pulled down to inadequate *clearance* from another live conductor or other objects that could cause a flashover.

These cars are usually unpowered, and with unlined wheels.

Special caution shall be taken to ensure that the tow rope or chain is truly insulating. This tow rope should be kept in a clean and dry condition at all times.

### 5.5 Communications

The ability of the equipment operators, supervisory personnel and observers at critical points in the *pull section* (such as at *energized* line crossings) to communicate clearly and quickly with one another is extremely important when using the *tension stringing* method of installing *conductors*.

These personnel shall each have a radio system with a channel that is free from outside interference and is located at their operating position. Included in this communication channel should be the *puller* operator, the *tensioner* operator, the supervisor(s) and, if applicable, the person following the *running board* as it moves from tower to tower, and persons at intermediate check points.

Failure of any radio in the system shall be cause for immediate stoppage of the pulling operation.

The radio or telecommunication system used by the *puller* operator and the *tensioner* operator shall be a portable set with earphones and microphone, but with no conductive wire connection to the machine, which could become a dangerous electrical path to the operator in case of electrical contact during *stringing* and if the operator were to leave the bonded area with his radio still attached to his person.

## 6 Special earthing requirements

### 6.1 General

Clause 6 provides recommended temporary *earthing systems* for each of the work procedures used in the installation of *conductors*.

Most of the earthing protection described below applies to bare distribution and transmission *conductors*. However, it is important to realize that a covered overhead distribution *conductor* is subject to many of the same hazards during installation.

It is generally recognized that the insulation on these *conductors* should not be relied on for protection of equipment and personnel if a direct contact with an *energized conductor* occurs. Also, during the *stringing* process, the core of a covered *conductor* is exposed at the pulling end where a metallic *woven wire grip* is often used.

Where special techniques are required for insulated overhead distribution *conductors*, they will be mentioned herein.

The degree of earthing protection required for a given *conductor* installation project depends upon the exposure to electrical hazards which exists within the particular work area on the project.

In 6.3, the requirements are defined as "Minimum" and "Maximum": When new *conductors* are installed in an area remote from other *energized* lines or parallel adjacent lines, and with no thunderstorm activity present, the minimum earthing requirements, at least, shall be used. These minimum requirements include bonding and earthing of all equipment involved at pull and *tension sites*. In addition, running earths should be installed on all metallic pulling or *pilot ropes*, and on the *conductor* or *earth wire* in front of the pulling and tensioning equipment. When minimum earthing requirements are used, it should be noted that protection of workers from step and touch potential does not exist.

In contrast to the above, for a project located in a congested area involving exposure to numerous *energized* parallel lines or the crossing of existing *energized* lines, and/or where there is a high probability of thunderstorm activity and adverse weather conditions, maximum earthing requirements shall be used.

Such maximum earthing requirements include bonding and earthing of equipment, the use of running earths, *earth mats* at work sites, and *stringing block earths*. These earths and mats shall be sized and designed for a *fault current* where direct contact with an *energized* line is possible.

Sizing of the individual *earth clamps*, *earthing cable*, or *earth rods* are not detailed here.

Figures 12a to 12h show the recommended earthing procedures for the *conductor stringing* sequence of the work, where the electrical hazards due to any of the possibilities described in Clause 4 are severe and require maximum earthing requirements.

In addition to making sure switches on the new line under construction are open, earthing and other protective measures shall be employed to ensure reasonable and adequate protection to all personnel. The best safety precaution is to consider all equipment as if it could become *energized* at any time. The degree of protection provided for a specific project shall be a decision made by the project supervisor, subject only to the applicable regulations in force for that situation, and based on a clear understanding of the potential hazards. However, this document gives recommendations on *earthing systems* that have been developed over a number of years, and have proved effective.

When working in populated areas where onlookers could inadvertently wander into work site areas, additional measures for isolating the work site, such as safety observers and warning signs, are required. Work sites shall be surrounded with fence and warning signs prominently posted to alert onlookers to the danger.

## 6.2 Work site earthing systems

### 6.2.1 Overview

For transmission *conductor* activities earthing is required at the work site for *conductors*, overhead *earth wires*, *pulling ropes* and *pilot ropes*. Hereinafter for brevity, the word *conductor* will also include procedures that apply equally to overhead *earth wires*, metallic pulling and *pilot ropes*, unless specifically stated otherwise.

Subclauses 6.2.2 to 6.2.10 give specific *earthing system* recommendations for the equipment and other components used in the *conductor stringing* process.

For distribution *conductor* activities, where a system neutral *conductor* which is already earthed is available on an adjacent *circuit*, it is preferable to interconnect the *earth mat*, the *conductors* and the equipment earths to this existing system neutral, since the neutral provides a known low resistance path to earth. Normally, an *earth mat* is bonded to *earth rods*

driven around and within its perimeter to increase its earthing capabilities and provide convenient connection points for earthing devices. The primary purpose of the mat is to provide safety for workmen by limiting potential differences within its perimeter to safe levels in case of high currents which may flow if the *circuit* or *conductor* being worked became *energized* for any reason. Metallic surface mats and gratings are sometimes utilized for this same purpose. When used, these mats are employed at pull, tension and midspan splice sites.

## 6.2.2 Use of earth rods

### 6.2.2.1 General

Where *earth rods* are used, the resistance of the *earth rods* shall be electrically tested (meggered) to ensure the resistance of the *earth rod* is less than 25  $\Omega$ .

NOTE It is important to check that the protection on any *energized* line which could contact the *conductor* being installed is designed to clear the *fault current* if the impedance of the *earth rod* is as high as 25  $\Omega$ .

If an *earth rod* resistance of less than 25  $\Omega$  cannot be obtained, an *earth mat* (see Figure 12h) at the work site shall be used if the work site is at ground level, or an *equipotential earthing system* used in elevated work sites.

In addition, if there is the possibility of an electrical contact during the work process, then any *energized* line which has the possibility of contact with the line being worked on shall have its reclosing device locked out.

In order to ensure that the different *earth rods* at each work site have the same potential, they shall be bonded together with full sized *earth clamps* and *earthing cables*.

When installing *earth rods*, caution should be taken to avoid all underground utilities such as existing *energized* underground electric lines, gas, sewer, and water pipes, communications cables, etc. A check of underground utility services in the area may be needed before *earth rods* are installed.

### 6.2.2.2 Use of earthing sticks

All *earth clamps* used shall be designed so they can be applied and removed with an insulated *earthing stick*. The *earthing stick* is made of fibreglass, reinforced plastic or similar, with a particular, highly resistant connection and is of sufficient length to allow safe gripping and installation of *earth clamps*.

### 6.2.2.3 Cleaning of connections

Since the value of the *earthing system* depends on a low resistance path, a good electrical contact shall be ensured between the *earth clamp* and the surface to which it is to be applied.

### 6.2.2.4 Installation/removal of earth clamps

*Earth clamps* and cables shall first be connected to the *earth rod* or earthing source, and then to the object to be earthed. When removing earths, the *earth clamp* shall first be removed from the earthed object and then from the earthing source or *earth rod*. The object being earthed shall not be damaged from using the *earth clamp*.

When applying the *earth clamp* with an *earthing stick*, the clamp shall be held in position near the *conductor*, then snapped on quickly and firmly, and tightened. If an arc is drawn, the clamp shall not be withdrawn, but kept on the *conductor*, thus earthing the *conductor*.

In cases of **maximum** hazard from induction, *earth clamps* shall be installed and removed sequentially as detailed in 4.3.2.

### 6.2.3 Equipment earths

All equipment used in the process of *stringing conductors* should have at least one earth attachment point, usually at some convenient point on the frame. It is recommended that a special earthing bar be welded to the frame of all *conductor stringing* equipment during manufacture for attachment of the *earth clamp*.

A typical *earth clamp*, cable and *earth rod* for earthing of equipment at the pull and *tension sites*, or other work locations, are shown in Figure 12a. This *earth clamp* should also be bonded via an *earthing cable* to the *earth mat* and running earths where used.

### 6.2.4 Earths for conductor, earth wire, metallic and synthetic rope

It is recommended that a running earth be used on each *conductor* being installed. This running earth is placed on the *conductor* immediately in front of the *tensioner* at the *tension site*, and on the metallic *pulling rope* in front of the *puller* at the *pull site*. The running earth should also be bonded to the *earth mat* and equipment earths.

A typical running earth, cable and *earth rod* arrangement is shown in Figure 12b.

Where a synthetic rope is used as a *pulling rope* or as a *pilot rope*, the use of running earths or *stringing block earths* is not recommended where it is known there will be induction from adjacent *energized* lines. Over time it has been found that synthetic ropes have become high resistance *conductors*. Also, the surface of the rope may become wet from rain during use.

If running earths or *stringing block earths* are used on synthetic ropes, they will be the focal point for draining to earth of the electric field induced current. Experience has shown that, if the synthetic rope is stretched from the *pull site* to the *tension site* and is allowed to sit for a period of time, localized heating of the surface of the rope will occur at all contact points with an earth. In severe cases, this will cause localized burning of the rope, and may result in a rupture of the rope while under tension.

Also, if a synthetic rope is used to pull a metallic rope or a *conductor* which is earthed with a running earth, an insulating link should be used to connect the two. Otherwise, localized heating and burning of the synthetic rope eye due to induction will occur.

### 6.2.5 Earths for earth mat, conductors or earth wires

A typical *earth clamp*, cable and *earth rod* for earthing of the *earth mat*, or *conductors* or *earth wires* at the *puller* and *tension sites* are shown in Figure 12a. This *earth clamp* should also be bonded via the *earthing cable* to the equipment and running earths.

### 6.2.6 Earths for mid-span joining of conductors or earth wires

A typical *earth clamp*, cable and *earth rod* system for earthing of the *conductors*, when making mid-span *compression joints*, is shown in Figure 12c.

In this process, the *conductor* is pulled to the earth in mid-span with a non-conductive rope. The temporary mesh socks used to join the *conductors* are removed, and a permanent *compression joint* between the *conductor* ends is made.

The earths are always placed on each *conductor* with an *earthing stick*, before any workman makes contact with any *conductor*. If this is not done, the workman could find himself placed in a series connection with the *conductor* ends and be subject to dangerous levels of voltage and current from induction.



### 6.2.7 Earths for clipping in the conductors or earth wires

A typical *earth clamp*, cable and tower connection system for earthing of the *conductors*, when removing the *conductor* from the *stringing blocks* and placing it in the insulator clamps, is shown in Figure 12d.

### 6.2.8 Earths for installation of jumper loops for the conductor

A typical *earth clamp*, cable and tower connection system for earthing of the *conductor*, when making *jumper* loops in the *conductor* at dead-end *structures*, is shown in Figure 12e.

### 6.2.9 Stringing block earths

A typical *earth clamp*, cable and tower connection system for earthing of the *conductors* or *pulling rope*, via a *stringing block earth*, is shown in Figure 12f.

*Stringing block earths* are sometimes used on *stringing blocks* with a sheave lining, at intermediate towers, to drain to earth the effect of excessive induction from adjacent *energized circuits*.

If the *stringing block* has unlined metallic sheaves, with a good earthing path through the sheave to the block frame, then it is usual practice to earth the frame only and not use a *stringing block earth*.

When induction effects are severe, as per *stringing* phase with a parallel *energized circuit*, it is recommended that the earthing devices are made taking in consideration the over-heating effect involved with the current draining; a reasonable value applied on the field requires to limit the overheating to 50 °C in one hour with 150 A per single *conductor* drained through the earthing device. In this typical *stringing* configuration, on the towers installed at the beginning and at the end of each section, special *stringing blocks* are normally applied, rated and designed to drain the induced current with the previous parameter involved. A typical configuration provides whole aluminium sheaves or sheave with aluminium linings and a current drain system made by electrical brushes and a bronze collector disc; this is to allow a path for the current bypassing the sheave's bearing (see Figure 12g)

Usually, the *stringing block* is suspended from the insulator string, however, on heavy angle towers, the *stringing block* may be hung directly from the tower bridge. If the *stringing block* has a lined *conductor* sheave, it is recommended that the *stringing block* be isolated from the tower *structure* with an insulating link, or use a *stringing block earth*.

### 6.2.10 Earth mat

A typical *earth mat* system with double barrier is shown in Figure 12h. Other *earth mat* designs with a different mesh size and construction are acceptable provided they meet the following criteria.

The *earth mat* is a system of interconnected bare *conductors*, and a metallic mesh with *earth rods*. The *earth mat* is placed on the ground under the equipment at pull, tension and *compression joint* sites.

The purpose of the *earth mat* is to provide *equipotential* protection for personnel, and the mat itself shall never be installed in such a way that it could carry *fault current*.

Four *earth rods* shall be used, i.e. one at each corner of the *earth mat*.

The mat should be of sufficient size that all *conductor stringing* equipment can be situated entirely on the mat, and is contained within the inner barrier, and allow the required work to be accomplished.

The matting material and *earthing cables* shall be of sufficient size and durability to withstand both the physical requirements of the movement, and the support of the equipment.

Mat *conductors* and *earth rods* shall be interconnected. All equipment, *structures*, *anchors*, *pulling ropes*, *pilot ropes*, *conductor* and *earth wires* within the mat area shall be bonded to it. The equipment shall be connected by type A earths to the *earth rods* directly, and not via the *earth mat* mesh.

There shall be a double barrier, as shown in Figure 12h, around the *earth mat*, with restricted access to the inner *earth mat* area over an insulating mat. The double barrier prevents contact between a person or object inside the mat area and someone outside the mat area.

*Earth mats* shall be used at pull and *tension sites* and at any point in the *pull section* where ground-level work is being carried out. They are to be used when there is any possibility of contact with an existing *energized conductor*, switching error, or if induction is present.

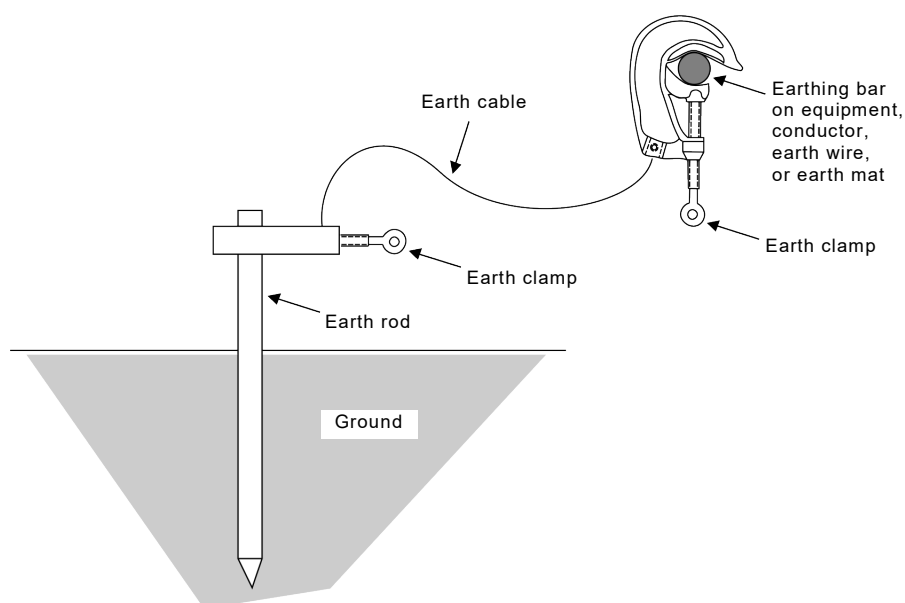

IEC

a) Equipment or conductor earth system – Type A

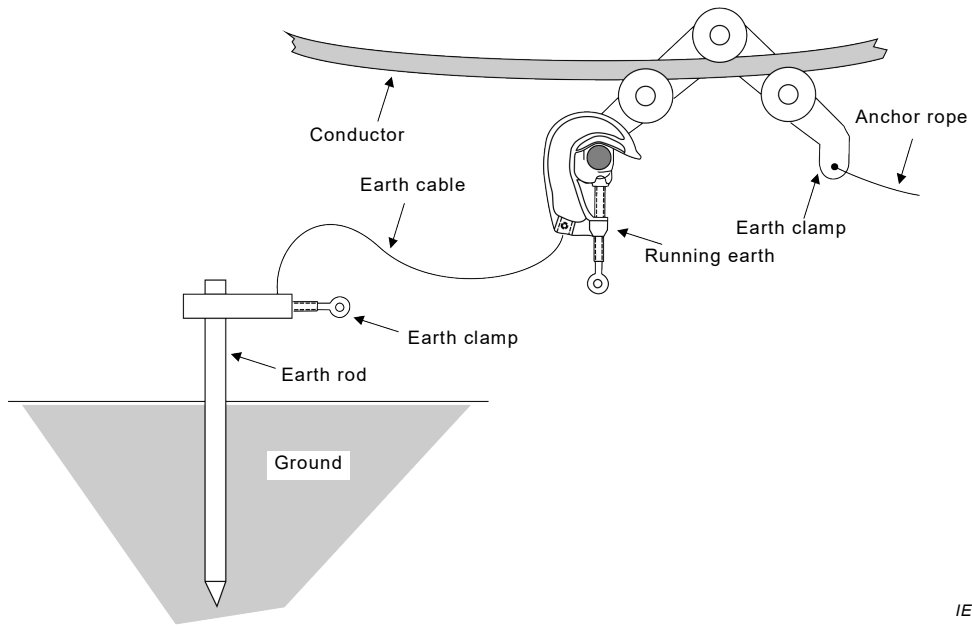

IEC

**b) Running earth system – Type B**

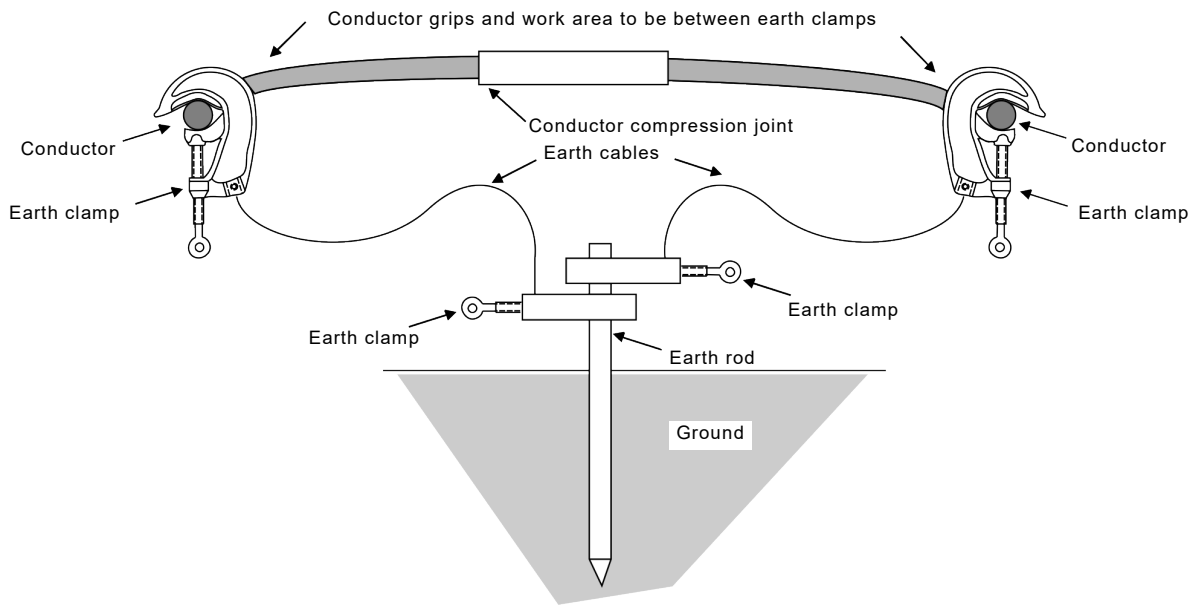

IEC

**c) Earthing system for conductor compression joints – Type C**

NOTE Other earth clamping systems that ensure good electrical contact are acceptable

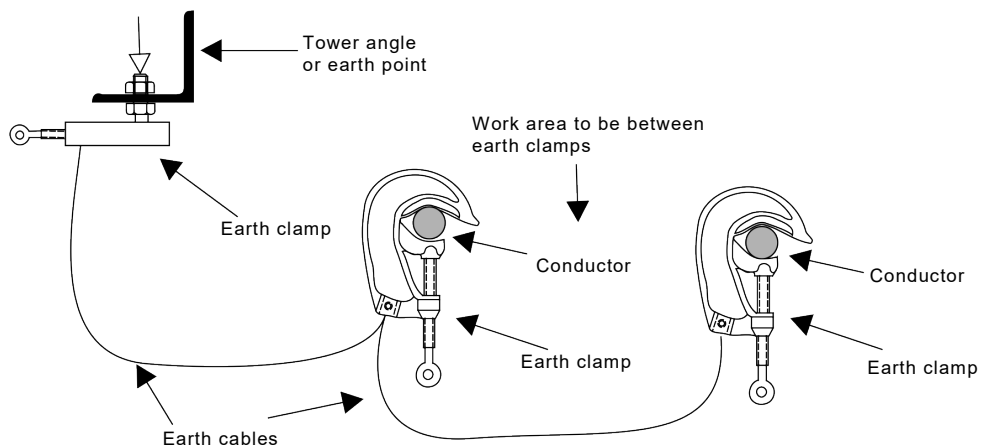

IEC

**d) Earthing system for clipping in conductors – Type D (two conductors per phase shown)**

NOTE Other earth clamping systems that ensure good electrical contact are acceptable

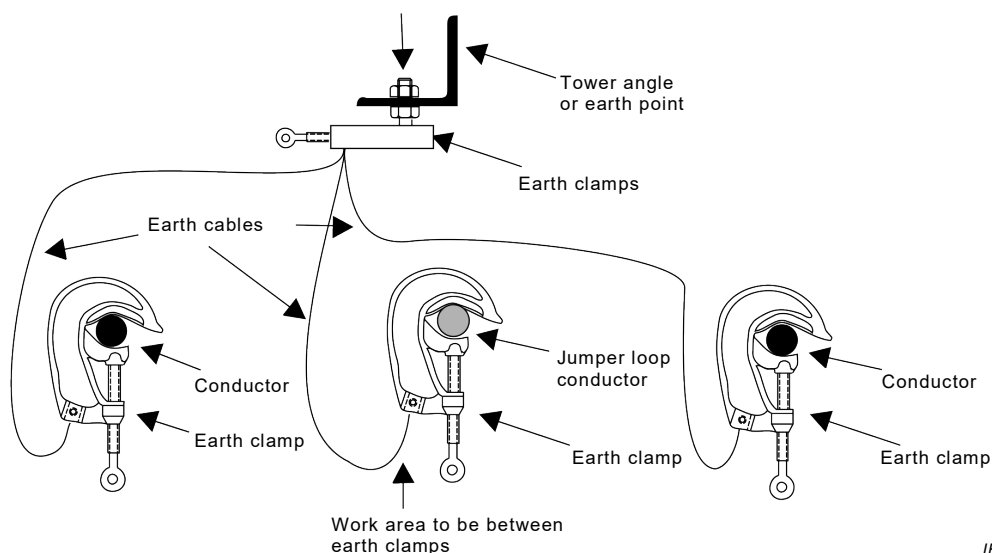

IEC

**e) Earthing system for conductor jumper loops – Type E**

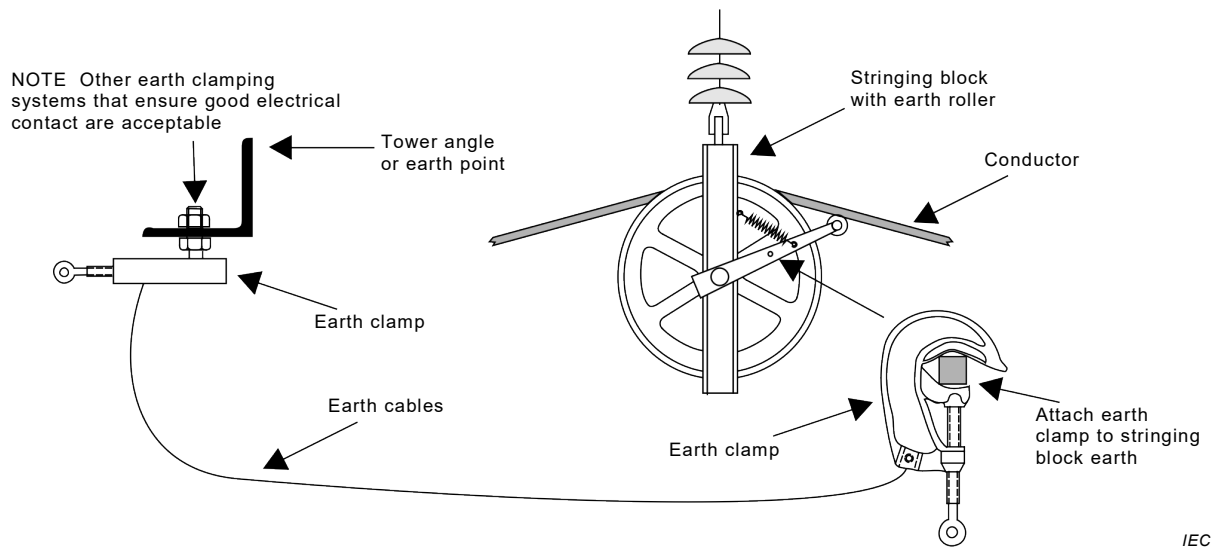

IEC

f) Earthing system for stringing block earths – Type F



IEC

g) Equipotential blocks with integrated current draining system through electrical brushes and bronze collector disc

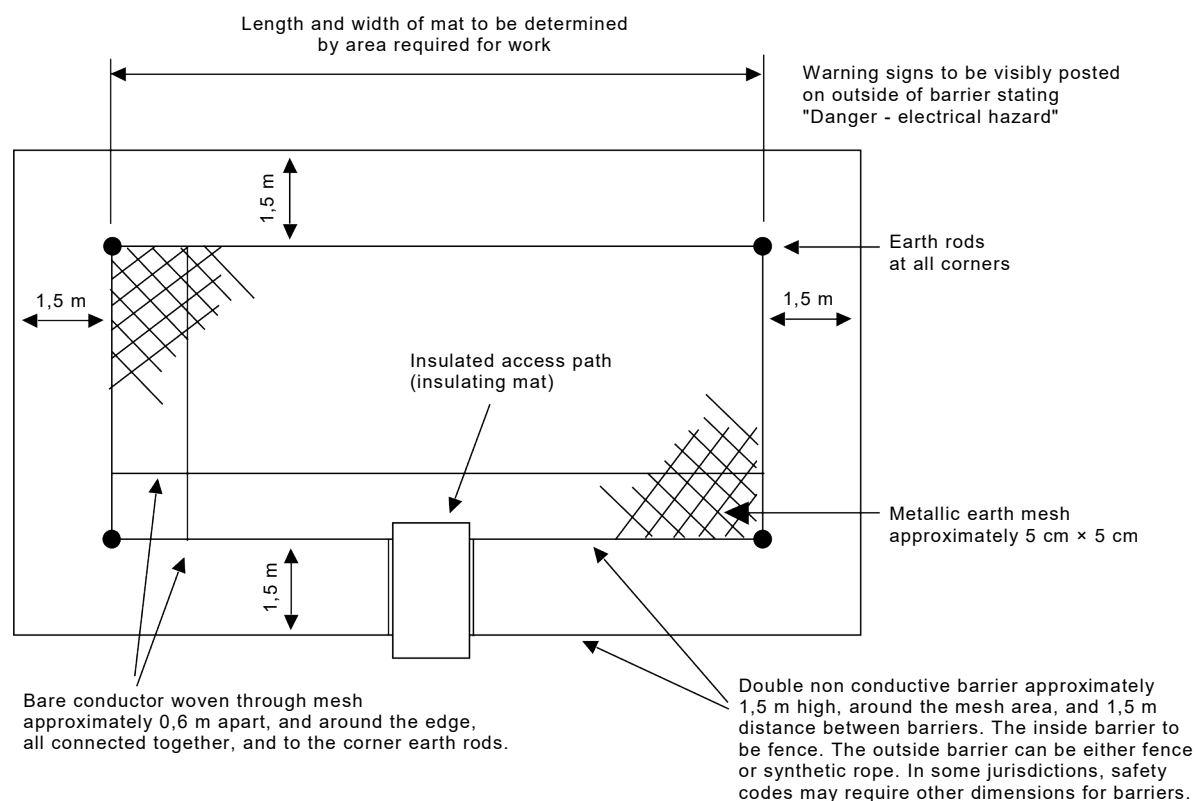

IEC

The work area shall be within the inner barrier, which shall contain all equipment, *anchors* and earths.

#### h) Typical earth mat

Figure 12 – Earthing systems

### 6.3 General procedures and use of earthing systems

#### 6.3.1 Overview

Subclause 6.3 details which *earthing system* should be used for each of the separate work sites of the *conductor stringing* process, and how it should be applied. For an overall review of earthing procedures, see Figures 5a, 5b, 6b, 6c, 6e, 6f, 6g and 6h.

NOTE Where a change in *earthing system* is required when one step of the *conductor stringing* process is completed and another begins, the new earth system specified is installed before the original earth system is removed. In this way, the *conductor*, ropes or equipment are always earthed and never left in an unearthed condition.

#### 6.3.2 General procedures

##### 6.3.2.1 General

Before work begins, there are some general procedures, detailed below, which are to be followed for all operations in order to protect personnel and equipment from electrical hazards, particularly when maximum earthing procedures are required.

##### 6.3.2.2 Choosing the correct equipment

It is important to choose equipment with sufficient capacity to perform the work to be done (see 5.4.2.3 and 5.4.3.3). This should ensure a margin of safety beyond the actual requirements of the work.

### 6.3.2.3 Pre-work check of equipment

When installing new *conductors* near existing energized *circuits* where electrical contact may occur, it is especially important that the equipment used such as *pullers*, *tensioners* and *pilot rope pullers* be thoroughly checked beforehand by competent trained persons to ensure they are functioning properly. In particular, braking systems should be checked to ensure correct operation and maximum load holding capability.

Pulling and *pilot ropes* should be examined for possible damage that may severely reduce their strength. It is recommended that a sample of synthetic ropes used as pulling or *pilot ropes* be tested for *ultimate strength* at least once each year. Weak or damaged ropes should be replaced.

Running earths, *earthing cables*, *earth clamps*, and *stringing block earths* should be checked to ensure they are operating correctly and have no broken or damaged parts that would negatively affect the desired low resistance earth path.

### 6.3.2.4 Pre-work conference

It is especially important where the possibility of the *conductors* being installed can become *energized* through induction, or when working near existing *energized conductors*, that all members of the work crew understand the hazards involved. They should have the work procedures and their duties clearly explained immediately before work begins. They should be aware of the necessity of using the earthing and bonding systems described herein, and they should know how to install them properly.

If the scope of the job changes, or if job personnel changes, work procedures and duties shall be explained once again to all personnel affected.

Before work begins, the project supervisor should travel the work site from *puller* site to *tensioner* site. This is done to ensure that all potential contact points with existing energized equipment or *conductors* are adequately protected from contact with the *conductor* being installed by *clearance*, by insulating covers or rider poles and nets.

### 6.3.2.5 Trained operators

The specialized equipment used in the *stringing of conductors* requires that operators be given special training beforehand in its safe and proper use. This is particularly important when they will be working on projects where maximum earthing procedures are required, due to the possibility of the *conductors* or equipment becoming *energized*.

## 6.3.3 Installation of the pilot or pulling rope

When installing the pilot or *pulling rope* in the *stringing blocks* on each tower from the *tension site* to the *pull site*, the following is required.

### Minimum

- An open switch (isolator) at all ends of the line being worked on. Secure against re-connection, and verify that the installation is *isolated*.
- All *conductor stringing* equipment at pull and *tension sites* shall be earthed with a type A earth system (see Figure 12a).
- All metallic ropes shall have a type B earth system (see Figure 12b) located in front of the rope reel. For synthetic pulling or *pilot ropes*, running earths should not be used (see 6.2.4).
- When the rope has been installed from the *tension site* to the *pull site*, the lead end of the rope shall be earthed using a type A earth system (see Figure 12a), until the rope is to be

attached to the *conductor*, at which time type B earths are to be installed at both the pull and *tension site* on both ends of the rope.

### Maximum

In addition to the above, add the following.

- The automatic recloser disabled on all *energized* lines being crossed or on *energized* lines in parallel where physical contact may occur as a result of an accident.
- *Crossing structures* (rider poles) over all *energized* lines being crossed (or *cradle blocks system* if applicable).
- All metallic ropes should have a non-conductive link, which can be a non-conductive rope, to attach them to the towing vehicle.
- All *stringing* equipment, plus temporary *anchors* for equipment, rope or *conductors*, shall be located in a type G *earth mat* area (see Figure 12h).
- The first *structure* in front of the *puller* and *tensioner*, as well as every third tower, shall have a type F *stringing block earth* system (see Figure 12f). In severe cases of induction, such as reconductoring a *circuit* on one side of a *structure* with a live high voltage *circuit* on the other side of the *structure*, it is recommended to have *stringing block earths* at every *structure* unless other methods of compensating for the induction are used. If the *stringing blocks* have unlined sheaves, they can be earthed through their frames. However, it should be noted that earthing through the frame may provide a slightly higher resistance path to earth compared to earthing directly on the *conductor* (see 6.2.9). Where synthetic pulling or pilot ropes are used, *stringing block earths* shall not be used (see 6.2.4).

For distribution lines, the following also apply.

- An insulating *conductor cover* shall be installed on all *energized conductors* being crossed for a minimum horizontal distance of 1,0 m on each side of the position where the new *conductors* are to be installed. The relative separation between the new and existing *conductors* and the effect of side wind should be taken into account when deciding on the length of insulating *conductor cover* to be used. *Crossing structures* (rider poles) with guard nets over all *energized conductors* being crossed are an acceptable alternative.
- Where an existing *energized circuit* is below or above the new *conductors* being installed, and on the same pole, each *energized conductor* should be temporarily offset, with earthing poles a minimum horizontal distance of 1,0 m from the position where the new *conductor* is to be installed. This operation is to be carried out before the installation of *pilot rope*, *pulling rope* or the new *conductors*.

#### 6.3.4 Stringing of conductors

When the *conductor* is being pulled into place from the *tension site* to the *pull site*, the following is required.

### Minimum

- An open switch (isolator) at all ends of the line being worked on. Secure against re-connection, and verify that the installation is *isolated*.
- All *conductor stringing* equipment, plus temporary *anchors* for equipment, rope or *conductors*, at pull and *tension sites* shall be earthed with a type A earth system (see Figure 12a).
- While *stringing*, all ropes shall have a type B earth system (see Figure 12b) located in front of the *puller*.
- While *stringing*, all *conductors* shall have a type B earth system (see Figure 12b) located in front of the *tensioner*.



- When *stringing* is completed, and the *conductors* tied down waiting for *sagging*, all *conductors* shall have a type A earth system (see Figure 12a).
- The *conductors* shall be pulled high enough before anchoring that they clear the ground level at all points, so accidental contact is prevented at any place along the line.

### Maximum

In addition to the above, add the following.

- The automatic recloser disabled on all *energized* lines being crossed or on *energized* lines in parallel where physical contact may occur as a result of an accident.
- *Crossing structures* (rider poles) over all *energized* lines being crossed (or *cradle blocks system* if applicable).
- All *conductor stringing* equipment shall be located in a type G *earth mat* area (see Figure 12h).
- The first *structure* in front of the *puller* and *tensioner*, as well as every third tower, shall have a type F *stringing block earth* system (see Figure 12f). In severe cases of induction, such as reconductoring a *circuit* on one side of a *structure* with a live high voltage *circuit* on the other side of the *structure*, it is recommended to have *stringing block earths* at every *structure* unless other methods of compensating for the induction are used. If the *stringing blocks* have unlined sheaves, they can be earthed through their frames. However, it should be noted that earthing through the frame may provide a slightly higher resistance path to earth compared to earthing directly on the *conductor* (see 6.2.9). Where synthetic pulling or *pilot ropes* are used, *stringing block earths* shall not be used (see 6.2.4).

For distribution lines, the following also apply.

- An insulating *conductor cover* shall be installed on all *energized conductors* being crossed for a minimum horizontal distance of 1,0 m on each side of the position where the new *conductors* are to be installed. The relative separation between the new and existing *conductors* and the effect of side wind should be taken into account when deciding on the length of insulating *conductor cover* to be used. *Crossing structures* (rider poles) with guard nets over all *energized conductors* being crossed are an acceptable alternative.
- Where an existing *energized circuit* is below or above the new *conductors* being installed, and on the same pole, each *energized conductor* should be temporarily offset, with earthing poles a minimum horizontal distance of 1,0 m from the position where the new *conductor* is to be installed. This operation is to be carried out before the installation of *pilot rope*, *pulling rope* or the new *conductors*.

### 6.3.5 Splicing of conductors

When the *conductor compression joint* or splice is made at the pull or *tension sites*, or in mid-span locations, the following is required.

#### Minimum

- An open switch (isolator) at all ends of the line being worked on. Secure against re-connection, and verify that the installation is *isolated*.
- All *conductors* shall be earthed before *splicing* with a type C earth system (see Figure 12c).

If the *compression joint* is to be made in mid-span, the *conductor* is pulled down to the ground level and let up after the joint is made with a non-conductive synthetic rope or, if a metallic rope is used, the winching equipment is earthed using a type A earth system (see Figure 12a).

- When the *conductor* reaches ground level, it shall be earthed on each side of the work site before *splicing* with a type C earth system (see Figure 12c).

## Maximum

In addition to the above, add the following.

- The automatic recloser disabled on all *energized* lines being crossed or on *energized* lines in parallel where physical contact may occur as a result of an accident.
- *Crossing structures* (rider poles) over all *energized* lines being crossed.
- All *splicing* in front of the *tensioner* or in mid-span shall be done within a type G *earth mat* area (see Figure 12h). All temporary *anchors* for *conductors* shall be located in the *earth mat* area.
- The *conductor* shall be earthed on each side of a mid-span *splicing* area using a type C earth system (see Figure 12c). The *earth rod* shall be connected to the *earth mat*.
- The first *structure* in front of the *puller* and *tensioner*, as well as every third tower shall have a type F *stringing block earth* system (see Figure 12f). In severe cases of induction, such as reconductoring a *circuit* on one side of a *structure* with a live high voltage *circuit* on the other side of the *structure*, it is recommended to have *stringing block earths* at every *structure* unless other methods of compensating for the induction are used. If the *stringing blocks* have unlined sheaves, they can be earthed through their frames. However, it should be noted that earthing through the frame may provide a slightly higher resistance path to earth compared to earthing directly on the *conductor* (see 6.2.9). Where synthetic pulling or *pilot ropes* are used, *stringing block earths* shall not be used (see 6.2.4).

### 6.3.6 Sagging of conductors

When the *conductor* is to be pulled up to the final sag, the following is required.

## Minimum

- An open switch (isolator) at all ends of the line being worked on. Secure against re-connection, and verify that the installation is *isolated*.
- During *sagging*, all *conductors* shall have a type B earth system (see Figure 12b), located in front of the *sagging* machine.

## Maximum

In addition to the above, add the following.

- The automatic recloser disabled on all *energized* lines being crossed or on *energized* lines in parallel where physical contact may occur as a result of an accident.
- *Crossing structures* (rider poles) over all *energized* lines being crossed.
- The sag machine shall be earthed with a type A earth system (see Figure 12a).
- All temporary *anchors* for *conductors* shall be located in an *earth mat* area (see Figure 12h).
- The first *structure* in front of the *puller* and *tensioner*, as well as every third tower shall have a type F *stringing block earth* system (see Figure 12f). In severe cases of induction, such as reconductoring a *circuit* on one side of a *structure* with a live high voltage *circuit* on the other side of the *structure*, it is recommended to have *stringing block earths* at every *structure* unless other methods of compensating for the induction are used. If the *stringing blocks* have unlined sheaves, they can be earthed through their frames. However, it should be noted that earthing through the frame may provide a slightly higher resistance path to earth compared to earthing directly on the *conductor* (see 6.2.9). Where synthetic pulling or *pilot ropes* are used, *stringing block earths* shall not be used (see 6.2.4).

### 6.3.7 Clipping-in conductors

When the *conductor* is transferred from the *stringing blocks* to the *conductor clamp* at the end of the insulator string after *sagging* is complete, the following is required.

#### Minimum

- An open switch (isolator) at all ends of the line being worked on. Secure against re-connection, and verify that the installation is *isolated*.
- At the tower where the *clipping-in* takes place, all *conductors* in the phase shall be earthed before *clipping-in* to a tower angle or earth point with a type D earth system (see Figure 12d).

#### Maximum

In addition to the above, add the following.

- The automatic recloser disabled on all *energized* lines being crossed or on *energized* lines in parallel where physical contact may occur as a result of an accident.
- *Crossing structures* (rider poles) over all *energized* lines being crossed.
- All temporary *anchors* for *conductors* shall be located in an *earth mat* area (see Figure 12h).
- The first *structure* in front of the *puller* and *tensioner*, as well as every third tower shall have a type F *stringing block earth* system (see Figure 12f). In severe cases of induction – such as reconductoring a *circuit* on one side of a *structure* with a live high voltage *circuit* on the other side of the *structure*, it is recommended to have *stringing block earths* at every *structure* unless other methods of compensating for the induction are used. If the *stringing blocks* have unlined sheaves, they can be earthed through their frames. However, it should be noted that earthing through the frame may provide a slightly higher resistance path to earth compared to earthing directly on the *conductor*. Where synthetic pulling or *pilot ropes* are used, *stringing block earths* should not be used (see 6.2.4).

### 6.3.8 Dead-ending and installation of jumper loops

When, after *sagging* has been completed, the *conductor* is terminated (*dead-ending*) and anchored to the horizontal insulator string at an *anchor structure*, or when the *anchor structure jumper* loops are installed, or when connecting the *conductor* to a transformer or underground cables or similar work, the following is required.

#### Minimum

- An open switch (isolator) at all ends of the line being worked on. Secure against re-connection, and verify that the installation is *isolated*.
- When *tractors* and rigging are used to pull the horizontal string and *conductor* up to the *anchor structure* arm for pinning, the *tractor* shall be earthed using a type A earth system (see Figure 12a).
- When the *conductor* is attached to the *anchor structure*, and/or the *jumper* loops are ready to be installed, all *conductors* in the phase on each side of the *anchor structure* shall be earthed to a tower angle or earth point with a type E earth system (see Figure 12e). The *earth clamps* shall be placed on the *conductor* outside the work area.

#### Maximum

In addition to the above, add the following.

- The automatic recloser disabled on all *energized* lines being crossed or on *energized* lines in parallel where physical contact may occur as a result of an accident.
- *Crossing structures* (rider poles) over all *energized* lines being crossed.

In addition to the above, when the *jumper* loops are being installed from the bucket of a crane, add the following.

- The crane frame shall be earthed with a type A earth system (see Figure 12a). The crane frame shall also be earthed to the tower leg with a type A earth system when working on a steel tower.
- The *jumper* loops and *conductor* shall be earthed with a type E earth system (see Figure 12e) and the free end of the *jumper* loop *conductor* also bonded to the crane boom or jib.
- A metallic grid shall be used on the bottom of a non-conductive man bucket, and shall be bonded to the *conductor* and *jumper* loop. For metallic man buckets, the bucket shall be bonded to the *conductor* and *jumper* loop.
- The crane operator shall stay in the crane at all times when it is connected to the *conductor* in any way. No one at ground level shall be allowed to touch the crane when it is connected to the *conductor*.

### 6.3.9 Spacing

For the installation of spacers, spacers/dampers, aircraft or bird warning devices, repair sleeves or other work in the span from a *conductor car*, the following is required.

#### Minimum

- An open switch (isolator) at all ends of the line being worked on. Secure against re-connection, and verify that the installation is *isolated*.
- For the section of line being spaced, all *conductors* in the phase shall be earthed to a tower angle or an earth point at the beginning and end of the section with a type D earth system (see Figure 12d).
- When entering a *conductor car*, the operator should make sure the car is at the same potential as the operator before contact. This can be done by allowing the car to first contact the *conductor* to which the operator is bonded, or by attaching to the car first with a bonding wand.
- When the *conductor car* operator wishes to exit from the car at a tower and climb down the tower, he shall first earth the car to the tower *structure* using a type A earth system (see Figure 12a).

#### Maximum

In addition to the above, add the following.

- The automatic recloser disabled on all *energized* lines being crossed or on *energized* lines in parallel where physical contact may occur as a result of an accident.
- *Crossing structures* (rider poles) over all *energized* lines being crossed.
- The *conductor car* shall either have unlined metallic wheels riding on the *conductor*, or a bonding wheel riding on the *conductor* at all times.
- If the *conductor car* is to be lifted around the insulator string support clamp at each tower by the operator, the *conductor car* shall be bonded to the conductor before lifting from the conductor, and the *bond* clamp removed only after the *conductor car* has been placed on the *conductor* again, and the bonding wheel put in contact with the *conductor*.

### 6.3.10 Special work on conductors

During installation of *conductors* or during *de-energized* maintenance procedures, it is often necessary to do a repair sleeve, install aircraft or bird warning devices in a particular span. This work is usually done from a *conductor car* but, under some difficult circumstances, it is done from a work *basket* or platform hung from a helicopter. The following is required.

### Minimum

- An open switch (isolator) at all ends of the line being worked on. Secure against re-connection, and verify that the installation is *isolated*.
- For the section of line being worked on, all *conductors* in the phase shall be earthed to a tower angle or earth point at the beginning and end of the working section with a type D earth system (see Figure 12d).
- When entering a *conductor car*, the operator should make sure the car is at the same potential as the operator before contact. This can be done by allowing the car to first contact the *conductor* to which the operator is bonded, or by attaching to the car first with a bonding wand.
- When the *conductor car* operator wishes to exit from the car at a tower, and climb down the tower, he shall first earth the car to the tower *structure* using a type A earth system (see Figure 12a).

### Maximum

In addition to the above, add the following.

- The automatic recloser disabled on all *energized* lines being crossed or on *energized* lines in parallel where physical contact may occur as a result of an accident.
- *Crossing structures* (rider poles) over all *energized* lines being crossed.
- The *conductor car* shall either have unlined metallic wheels riding on the *conductor*, or a bonding wheel riding on the *conductor* at all times.
- If the *conductor car* is to be lifted around the insulator string support clamp at each tower by the operator, the *conductor car* shall be bonded to the conductor before lifting from the conductor, and the *bond* clamp removed only after the *conductor car* has been placed on the *conductor* again, and the bonding wheel put in contact with the *conductor*.

#### 6.3.11 Fuelling

When fuelling equipment from fuel trucks at pull and *tension sites*, the following is required.

### Minimum

- An open switch (isolator) at all ends of the line being worked on. Secure against re-connection, and verify that the installation is *isolated*.
- Before the fuel nozzle is inserted in the equipment fuel tank, the fuel truck or container shall first be bonded with a type A earth system (see Figure 12a) to the *earth rod* to which the equipment being refuelled is bonded.

### Maximum

In addition to the above add the following.

- All equipment within a type G *earth mat* system (see Figure 12h).

## 7 Testing of earthing devices

### 7.1 General

Clause 7 details the recommended electrical type tests required for *stringing block* earths and running earths. Type tests for *earth clamps*, *earthing cable*, etc. are detailed in IEC 61230.

## 7.2 Number of type tests

Each new design of *stringing block earth* or running earth shall undergo the type tests detailed in Clause 7. At least two successful tests on these earths, effected in sequence, shall be accomplished to consider their design is satisfactory.

Once the equipment has passed the type test, it is not considered necessary to test additional production units, unless the design is altered in a substantial way that would affect the earthing capabilities.

## 7.3 Type test set-up

The *stringing block earth* and the running earth shall be tested in essentially the same test set-up, as detailed in Figures 13 and 14.

## 7.4 Type test acceptance criterion

The type test acceptance criterion for *stringing block earths* and running earths is that they shall withstand a test current of 20 000 A symmetrical for 20 cycles.

In this test, the word “withstand” is interpreted to mean that the earth shall continue to pass current for the time period specified without interruption. Physical damage to the earth at this level of amperage is to be expected, but the earth parts shall survive long enough to hold its current path.

The *stringing block earths* and running earths accepted by this criterion will be suitable for the following:

- a) *fault currents* caused by accidental contact of the *conductor* being installed with existing live distribution lines. This may occur when the new *circuit* crosses over the existing distribution line;
- b) lightning strikes;
- c) induced voltages and currents.

**WARNING:** There may be cases where accidental contact could occur with an existing live high voltage transmission line. Special care shall be taken to choose *stringing block earths* and running earths which will carry the potential *fault current*, if such earths are required for this type of contact. The acceptance criterion described above may not be sufficient for these special cases.

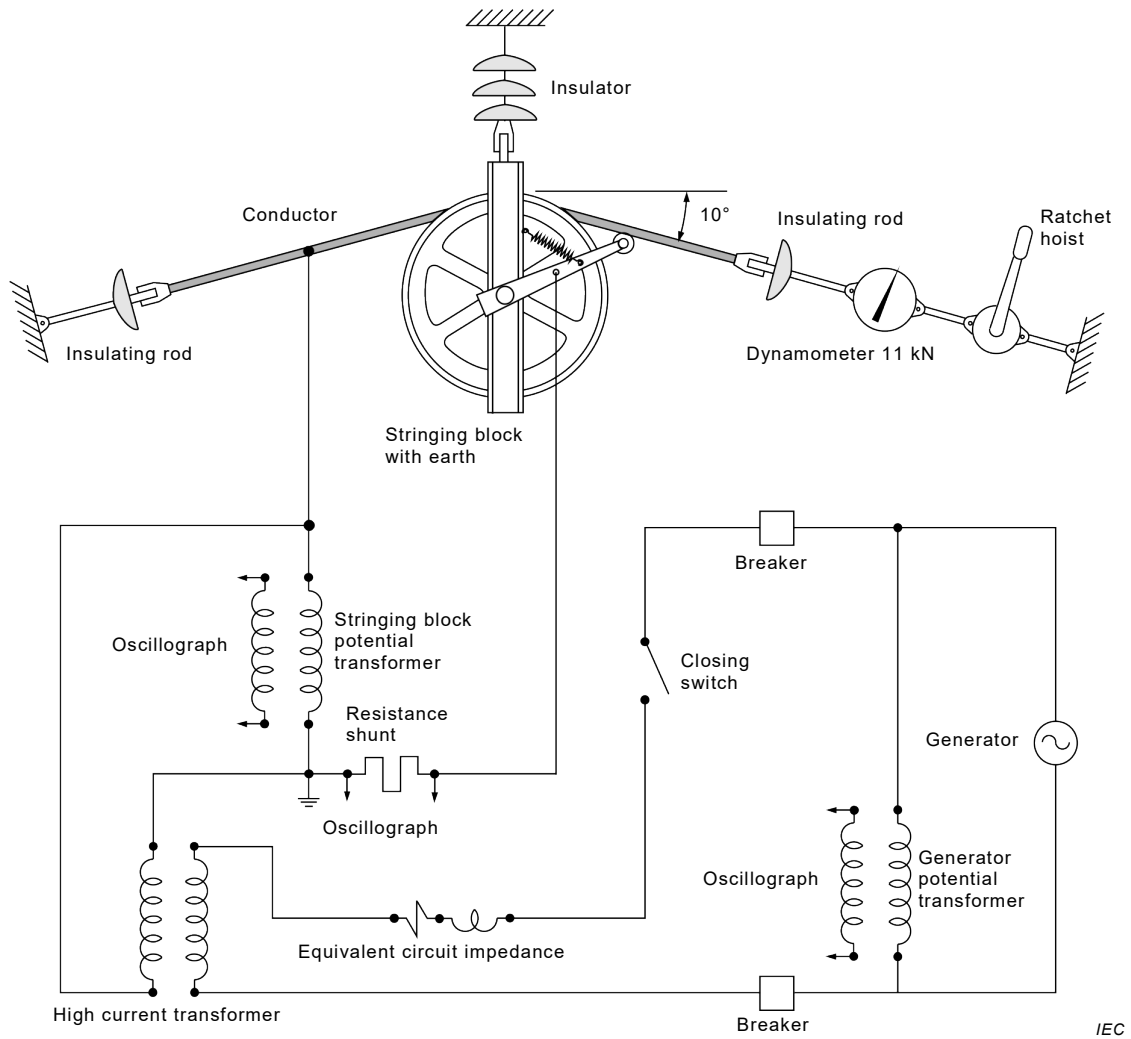

Figure 13 – Typical test set-up for stringing block earth

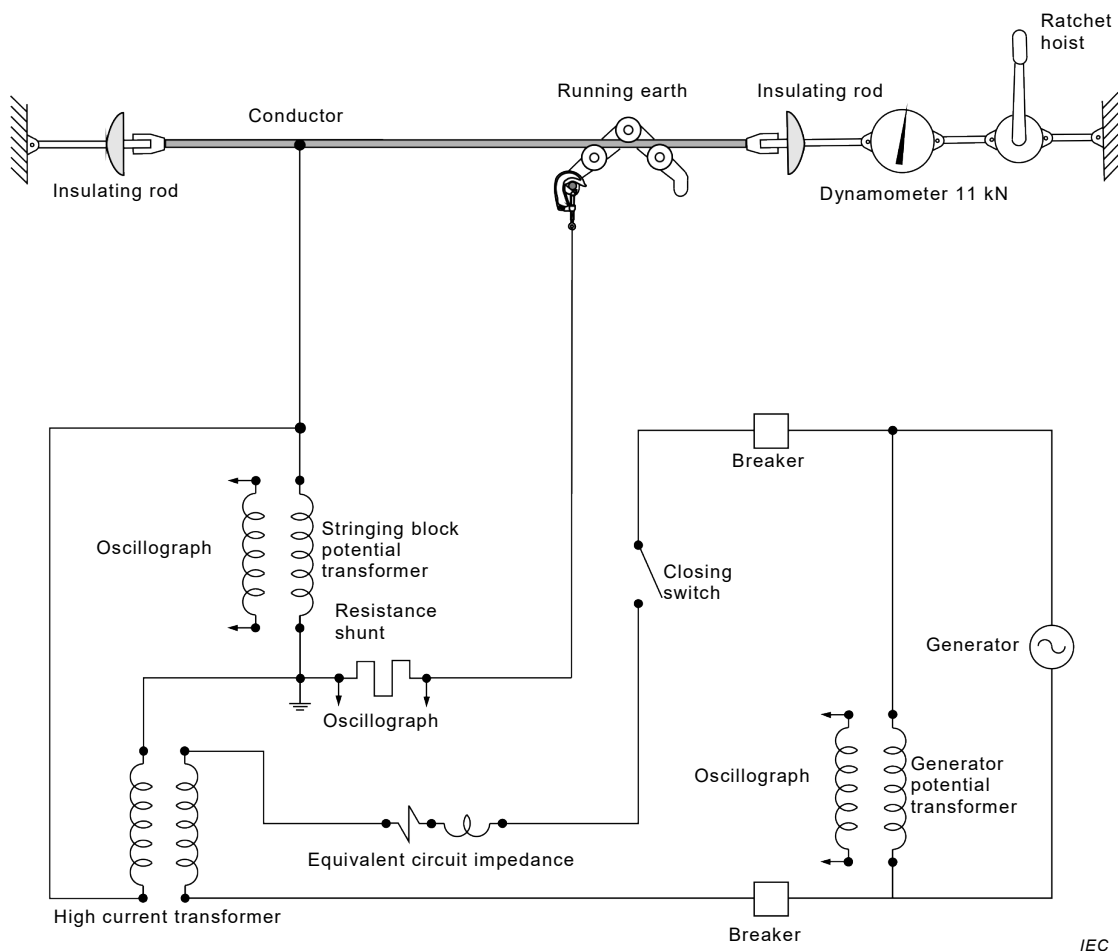

Figure 14 – Typical test set-up for running earth



## Bibliography

IEC 61230, *Live working – Portable equipment for earthing or earthing and short-circuiting*

EN 50374, *Conductor cars*

---





## Bureau of Indian Standards

BIS is a statutory institution established under the *Bureau of Indian Standards Act, 2016* to promote harmonious development of the activities of standardization, marking and quality certification of goods and attending to connected matters in the country.

### Copyright

BIS has the copyright of all its publications. No part of these publications may be reproduced in any form without the prior permission in writing of BIS. This does not preclude the free use, in the course of implementing the standard, of necessary details, such as symbols and sizes, type or grade designations. Enquiries relating to copyright be addressed to the Head (Publication & Sales), BIS.

### Review of Indian Standards

Amendments are issued to standards as the need arises on the basis of comments. Standards are also reviewed periodically; a standard along with amendments is reaffirmed when such review indicates that no changes are needed; if the review indicates that changes are needed, it is taken up for revision. Users of Indian Standards should ascertain that they are in possession of the latest amendments or edition by referring to the website-[www.bis.gov.in](http://www.bis.gov.in) or [www.standardsbis.in](http://www.standardsbis.in).

This Indian Standard has been developed from Doc No.: ETD 36 (18658).

### Amendments Issued Since Publication

Amend No.	Date of Issue	Text Affected

## BUREAU OF INDIAN STANDARDS

### Headquarters:

Manak Bhavan, 9 Bahadur Shah Zafar Marg, New Delhi 110002

Telephones: 2323 0131, 2323 3375, 2323 9402

Website: [www.bis.gov.in](http://www.bis.gov.in)

### Regional Offices:

	Telephones
Central : 601/A, Konnectus Tower -1, 6 <sup>th</sup> Floor, DMRC Building, Bhavbhuti Marg, New Delhi 110002	{ 2323 7617
Eastern : 8 <sup>th</sup> Floor, Plot No 7/7 & 7/8, CP Block, Sector V, Salt Lake, Kolkata, West Bengal 700091	{ 2367 0012 2320 9474
Northern : Plot No. 4-A, Sector 27-B, Madhya Marg, Chandigarh 160019	{ 265 9930
Southern : C.I.T. Campus, IV Cross Road, Taramani, Chennai 600113	{ 2254 1442 2254 1216
Western : Plot No. E-9, Road No.-8, MIDC, Andheri (East), Mumbai 400093	{ 2821 8093

**Branches :** AHMEDABAD. BENGALURU. BHOPAL. BHUBANESHWAR. CHANDIGARH. CHENNAI. COIMBATORE. DEHRADUN. DELHI. FARIDABAD. GHAZIABAD. GUWAHATI. HIMACHAL PRADESH. HUBLI. HYDERABAD. JAIPUR. JAMMU & KASHMIR. JAMSHEDPUR. KOCHI. KOLKATA. LUCKNOW. MADURAI. MUMBAI. NAGPUR. NOIDA. PANIPAT. PATNA. PUNE. RAIPUR. RAJKOT. SURAT. VISAKHAPATNAM.