औद्योगिक प्रयोजनों के लिए प्लग, फिक्स्ड
या पोर्टेबल सॉकेट आउटलेट और उपकरण
इनलेट

भाग 2 पिन और संपर्क नलिका साधित्रों की आयाम
विनियम अपेक्षाएँ
(दूसरा पुनरीक्षण)

**Plugs Fixed or Portable Socket-Outlets
and Appliance Inlets For Industrial
Purposes
Part 2 Dimensional Compatibility
Requirements for Pin and Contact-Tube
Accessories
(Second Revision)**

29.120.30

© BIS 2023

© IEC 2021



भारतीय मानक ब्यूरो

BUREAU OF INDIAN STANDARDS

मानक भवन, 9 बहादुर शाह ज़फर मार्ग, नई दिल्ली - 110002

MANAK BHAVAN, 9 BAHADUR SHAH ZAFAR MARG

NEW DELHI - 110002

www.bis.gov.in www.standardsbis.in

NATIONAL FOREWORD

This Indian Standard (Part 2) (Second Revision) which is identical with IEC 60309-2 : 2021 'Plugs, fixed or portable socket-outlets and appliance inlets for industrial purposes — Part 2: Dimensional compatibility requirements for pin and contact-tube accessories' issued by the International Electrotechnical Commission (IEC) was adopted by the Bureau of Indian Standards on the recommendation of the Electrical Wiring Accessories Sectional Committee and approval of the Electrotechnical Division Council.

This standard was originally published in 1996 and subsequently revised in year 2002 to bring it in line with latest IEC. The second revision of this standard has been undertaken to align it with the latest version of IEC 60309-2 to make a pace with the latest developments that have taken place at international level.

The text of IEC standard has been approved as suitable for publication as an Indian Standard without deviations. Certain terminologies and conventions are, however, not identical to those used in Indian Standards. Attention is particularly drawn to the following:

- a) Wherever the words 'International Standard' appear referring to this standard, they should be read as 'Indian Standard'; and
- b) Comma (,) has been used as a decimal marker, while in Indian Standards the current practice is to use a point (.) as the decimal marker.

In this standard, reference appears to International Standards for which Indian Standards also exists. The corresponding Indian Standards, which are to be substituted, are listed below along with their degree of equivalence for the editions indicated:

<i>International Standard</i>	<i>Corresponding Indian Standard</i>	<i>Degree of Equivalence</i>
IEC 60309-1 : 2021 Plugs, fixed or portable socket-outlets and appliance inlets for industrial purposes — Part 1: General requirements	IS/IEC 60309-1 : 2021 Plugs, fixed or portable socket-outlets and appliance inlets for industrial purposes Part 1: General requirements	Identical

The Committee has reviewed the provisions of the following international standards referred in this adopted standard and decided that they are acceptable for use in conjunction with this standard:

<i>International Standard</i>	<i>Title</i>
IEC 60364-4-41	Low-voltage electrical installations — Part 4-41: Protection for safety — Protection against electric shock

Only the English language text has been retained while adopting it in this Indian Standard, and as such, the page numbers given here are not the same as in the IEC Publication.

For the purpose of deciding whether a particular requirement of this standard is complied with the final value, observed or calculated expressing the result of a test or analysis shall be rounded off in accordance with IS 2 : 2022 'Rules for rounding of numerical values (*second revision*)'. The number of significant places retained in the rounded off value should be the same as that of the specified value in this standard.

CONTENTS

1	Scope	1
2	Normative references	1
3	Terms and definitions	2
4	General	2
5	Standard ratings	2
6	Classification of accessories.....	3
7	Marking	4
8	Dimensions.....	6
	8.2.1 General	17
	8.2.2 Checking plugs and appliance inlets	18
	8.2.3 Checking socket-outlets.....	21
9	Protection against electric shock	27
10	Provision for earthing	27
11	Terminals and terminations.....	27
12	Interlocks.....	29
13	Resistance to ageing of rubber and thermoplastic material	29
14	Construction	29
15	Construction of fixed socket-outlets	32
16	Construction of plugs and portable socket-outlets	32
17	Construction of appliance inlets	33
18	Degrees of protection	33
19	Insulation resistance and dielectric strength	33
20	Breaking capacity	34
21	Normal operation	34
22	Temperature rise	34
23	Flexible cables and their connection	34
24	Mechanical strength	34
25	Screws, current-carrying parts and connections.....	34
26	Creepage distances, clearances and distances through sealing compound.....	35
27	Resistance to heat, to fire and to tracking.....	35
28	Corrosion and resistance to rusting	35
29	Conditional short-circuit current withstand test.....	35
30	Electromagnetic compatibility	35
	Bibliography.....	69
	Figure 201 – 16/20 A, 32/30 A, 63/60 A and 125/100 A socket-outlets having rated operating voltages exceeding 50 V – "go" gauges for checking dimensions d_1 , d_2 , l_1	12
	Figure 202 – 16/20 A, 32/30 A, 63/60 A and 125/100 A socket-outlets having rated operating voltages exceeding 50 V – "no-go" gauges for checking dimensions d_1 , d_2	13

Figure 203 – 16/20 A, 32/30 A, 63/60 A and 125/100 A plugs and appliance inlets having rated operating voltages exceeding 50 V – "go" gauges for checking dimensions d_2 , d_4 , l_1	14
Figure 204 – 16/20 A, 32/30 A, 63/60 A and 125/100 A plugs and appliance inlets having rated operating voltages exceeding 50 V – "NO-GO" gauges for checking dimensions d_2 , d_4	15
Figure 205 – 16/20 A and 32/30 A socket-outlets having rated operating voltages not exceeding 50 V – Gauges for checking compatibility	16
Figure 206 – 16/20 A and 32/30 A plugs and appliance inlets having rated operating voltages not exceeding 50 V – Gauges for checking compatibility	17
Figure 207 – "NO-GO" gauges for checking 16/20 A, 32/30 A, 63/60 A and 125/100 A plugs and appliance inlets having rated operating voltages exceeding 50 V	19
Figure 208 – 16/20 A and 32/30 A plugs and appliance inlets having rated operating voltages not exceeding 50 V – Gauges for checking rigidity of enclosures of thermoplastic material under humid and warm conditions.....	19
Figure 209 – Device for testing non-solid pins.....	21
Figure 210 – Arrangement for test using "NO-GO" gauge for checking 16/20 A, 32/30 A, 63/60 A and 125/100 A socket-outlets having rated operating voltages exceeding 50 V	23
Figure 211 – Gauges for checking socket-outlets of 16/20 A, 32/30 A, 63/60 A and 125/100 A having rated operating voltages exceeding 50 V	24
Figure 212 – 16/20 A and 32/30 A socket-outlets having rated operating voltages not exceeding 50 V – Gauges for checking rigidity of enclosures of thermoplastic material under humid and warm conditions.....	25
Figure 213 – Gauge for checking phase holes	26
Figure 214 – Test of phase hole.....	26
Figure 215 – Socket-outlets with enclosures of resilient or thermoplastic material –Gauge for checking impossibility of single-pole insertion of a 10/16 A 250 V two-pole plug 33.....	27
Figure 216 – Example of apparatus for checking the withdrawal force.....	30
Table 201 – Rated currents.....	3
Table 202 – Examples of marking for series I.....	4
Table 203 – Examples of marking for series II.....	4
Table 204 – Accessories with rated operating voltages exceeding 50 V	7
Table 205 – Accessories with rated operating voltages not exceeding 50 V	8
Table 206 – Retaining devices	8
Table 207 – Forces applied to "GO"/"NO-GO" gauges.....	9
Table 208 – General purpose accessories with rated operating voltage not exceeding 50 V16	10
Table 209 – Special application accessories with rated operating voltage not exceeding 50 V	10
Table 210 – Positions of earthing contact	10
Table 211 – Test forces	18
Table 212 – Maximum displacement of the gauges	22
Table 3 – Size of connectable conductors.....	28
Table 213 – Pulling force on terminals	28
Table 214 – Diameter of pins of the test plug	29

Table 215 – Maximum withdrawal forces.....	30
Table 216 – Withdrawal forces.....	31

*Indian Standard***PLUGS FIXED OR PORTABLE SOCKET-OUTLETS
AND APPLIANCE INLETS FOR INDUSTRIAL PURPOSES
PART 2 DIMENSIONAL COMPATIBILITY REQUIREMENTS FOR PIN
AND CONTACT-TUBE ACCESSORIES***(Second Revision)***1 Scope**

This document applies to plugs, fixed or portable socket-outlets, and appliance inlets, hereinafter referred to as accessories, with a rated operating voltage not exceeding 1 000 V DC or 1 000 V AC with a frequency not exceeding 500 Hz and a rated current not exceeding 125 A, primarily intended for industrial use, either indoors or outdoors.

These accessories are intended to be installed by instructed persons or skilled persons only.

NOTE 1 All references for accessories with a rated current of more than 125 A in IEC 60309-1 are not applicable to this document.

This document applies to accessories with pins and contact-tubes of standardized configurations.

This document applies to accessories, for use when the ambient temperature is normally within the range $-25\text{ }^{\circ}\text{C}$ to $40\text{ }^{\circ}\text{C}$.

The use of these accessories on building sites and for agricultural, commercial and domestic applications is not precluded.

This document applies to accessories with screwless-type terminals or insulation piercing terminals, with a rated current up to and including 32 A for series I and 30 A for series II.

Socket-outlets or appliance inlets incorporated in or fixed to electrical equipment are within the scope of this document. This document also applies to accessories intended to be used in extra-low voltage installations.

NOTE 2 This document does not apply to accessories primarily intended for domestic and similar general purposes.

In locations where special conditions prevail, for example on board ship or where explosions are liable to occur, additional requirements can be necessary.

2 Normative references

Clause 2 of IEC 60309-1:2021 applies except as follows:

Additional normative references:

IEC 60309-1:2021, *Plugs, fixed or portable socket-outlets and appliance inlets for industrial purposes – Part 1: General requirements*

IEC 60364-4-41, *Low-voltage electrical installations – Part 4-41: Protection for safety – Protection against electric shock*

3 Terms and definitions

Clause 3 of IEC 60309-1:2021 applies except as follows:

Additional terms and definitions:

3.201

phase inverter

plug or appliance inlet with operating means to interchange the position of two phase-pins without disconnecting them from the conductors

3.202

solid pin

pin made from a single homogeneous material, without holes, slots, slits or similar outside the terminal area

4 General

Clause 4 of IEC 60309-1:2020 applies except as follows:

4.1 *Replace the fifth paragraph by the following:*

In this document:

2P + E covers both 2P + E and 1P + N + E and

3P + E covers both 3P + E and 2P + N + E

unless specifically excluded (see Table 208).

Additional subclause:

4.201 If gauges are used, they shall be of hardened steel, all corners shall be slightly rounded-off with a maximum radius of 0,1 mm and, if not otherwise specified, the surface finish for all measurement surfaces shall be $\sqrt{\text{Ra}}$ minimum.

5 Standard ratings

Clause 5 of IEC 60309-1:2021 applies except as follows:

5.1 Replace the existing text with the following:

Preferred rated operating voltage range or rated operating voltage
20 V to 25 V
40 V to 50 V
100 V to 130 V
200 V to 250 V
277 V
380 V to 415 V
440 V to 460 V
480 V to 500 V
600 V to 690 V
750 V
1 000 V

5.2 Replace the existing text and Table 1 with the following:

Standard rated currents are given in Table 201.

Table 201 – Rated currents

Series I	Series II
A	A
16	20
32	30
63	60
125	100

Additional subclause:

5.201 The standard IP ratings according to IEC 60529 are:

- IP44,
- IP67,
- IP66/IP67,
- IP67/IP69,
- IP66/IP67/IP69.

6 Classification of accessories

Clause 6 of IEC 60309-1:2021 applies except as follows:

6.2 Not applicable.

7 Marking

Clause 7 of IEC 60309-1:2021 applies except as follows:

7.1 *Replace the sentence before the compliance statement at the end of the subclause by the following paragraphs:*

The symbol indicating the position of the earthing contact or of the minor key or keyway shall be placed before or above the value for the rated operating voltage and separated from it by a line.

These markings shall be placed after the marking for rated current, separated from it by a dash if an oblique line separates the symbol indicating the position of the earthing contact or of the minor key or keyway from the value for the rated operating voltage.

If a symbol for nature of supply is used, it shall be placed after or below the marking for rated operating voltage.

For three-phase accessories it is not necessary to mark the voltage phase to neutral, if any.

The marking for rated current(s), position of the earthing contact or the minor key, keyway, rated operating voltage(s) and nature of supply accordingly may be as follows.

Table 202 – Examples of marking for series I

16 A – 9 h/400 V~	16 – 9 h/400~	$16 - \frac{9h}{400\sim}$
16 A – 9 h/380-415 V~	16 – 9 h/380-415~	$16 - \frac{9h}{380-415\sim}$
32 A – 6 h/230/400 V~	32 – 6 h/230/400~	$32 - \frac{6h}{230 / 400 \sim}$
$32 A - \frac{6h/220/380 V \sim}{240 / 415 V \sim}$	$32 - \frac{6h/220/380 \sim}{240 / 415 V \sim}$	$32 \frac{6h}{200/346 \sim} / 240 / 415 \sim$

Table 203 – Examples of marking for series II

20 A – 7 h/480 V AC	20 A – 7 h/480~	$20 A - \frac{7h}{480\sim}$
30 A – 7 h/480 V	3 Phase, or 30 A – 7 h/480, 3Φ	$30 A - \frac{7h}{480 V, 3\Phi}$
60 A – 7 h/277/480 V, 3 Phase Y	60 A – 7 h/277/480, 3ΦY	$60 A - \frac{7h}{277 / 480 V, 3\Phi Y}$

It is allowed to put the symbols for AC (~) [IEC 60417-5032 (2002-10)] and DC (===) [IEC 60417-5031 (2002-10)] or (—) [IEC 60417-5006 (2002-10)] after the values.

The drawings of standard sheets 2-I, 2-II, 2-III and 2-IV show accessories with the symbol 6 h, and those of standard sheets 2-VIII and 2-IX show accessories with the symbol 12 h.

For accessories having rated operating voltages exceeding 50 V, the symbol indicating the position of the earthing contact shall be a numeral followed by the letter h.

The numeral is derived from the position of the earth contact tube, when compared with the face of a clock, the socket-outlet being viewed from the front with the keyway at the sixth hour.

For accessories having rated operating voltages not exceeding 50 V, the symbol indicating the position of the minor key shall be a numeral followed by the letter h.

The numeral is derived from the position of the minor key, when compared with the face of a clock, the socket-outlet being viewed from the front with the major key at the sixth hour.

For plugs and appliance inlets, the symbol indicating the position of the earthing contact or the minor keyway shall be the same as that for the corresponding socket-outlet.

Contact tubes of socket-outlets shall be positioned in the clockwise order when viewed from the front as shown in the standard sheets (see also 7.5).

Pins of plugs and appliance inlets shall be positioned in the opposite order viewed from the front.

7.4 *Replace the existing text with the following:*

For plugs and portable socket-outlets, the marking specified in 7.1 shall be easily discernible when the accessory is wired ready for use.















The marking for insulation voltage shall be on the main part; it shall not be visible when the accessory is mounted and wired as in normal use.

NOTE The term "ready for use" does not imply that the plug or portable socket-outlet is engaged with its complementary accessory.

Compliance is checked by inspection.

7.5 *Replace the existing text with the following:*

For rewirable accessories, the contacts shall be indicated by the following symbols:

- for accessories with three contacts (phase + neutral + earth, or, phase + phase + earth):
L / +, unmarked,  (preferred) [IEC 60417-5019 (2006-08)] or  [IEC 60417-5017 (2006-08)]
except for Series II clock position 4 h and 5 h which are marked:
N, unmarked,  or 
- for accessories with four contacts (three-phase + earth):
L1, L2, L3,  or , or alternatively 1, 2, 3,  or 
except for Series II clock position 12 h (phase + centre tap + phase + earth) which is marked:
L1, N, L2,  or 
- for accessories with five contacts (three-phase + neutral + earth):
L1, L2, L3, N,  or , or alternatively 1, 2, 3, N,  or 
- for accessories having a rated operating voltage not exceeding 50 V, 8 h clock position for portable electric incubator: +12, +24.

IS/IEC 60309-2 : 2021

These symbols shall be placed close to the relevant terminals; they shall not be placed on screws, removable washers or other removable parts.

For phase inverters, these symbols shall conform in one position with the requirements of 7.1. In the other position of the inverting means, the phase marking need not conform.

Additional marking to indicate neutral terminal and/or earthing terminal may be used as follows:

- letter W and/or white colour for neutral;
- letter G and/or green colour for earthing.

No marking is required for terminals for pilot conductors. If they are marked, it is recommended to use the marking P or PILOT.

The values used with the letters may be written as an index. It is recommended that where practicable the symbol \oplus be used.

Compliance is checked by inspection.

7.7 *Add the following footnote reference to Table 2:*

- c) The 2P + N + E, 12 h, Series II accessories shall use the indicating colour orange.

8 Dimensions

Clause 8 of IEC 60309-1:2021 applies except as follows:

8.1 *Replace the existing text with the following:*

Accessories shall comply with the relevant standard sheets as specified below. For accessories having rated operating voltages exceeding 50 V, Table 204 applies.

Table 204 – Accessories with rated operating voltages exceeding 50 V

Accessory	Degree of protection	Standard sheet
16/20 A and 32/30 A	IP44	2-I 2-I continuation 1 2-II 2-II continuation 1
	IP67 IP67/IP69 IP66/IP67 IP66/IP67/IP69	2-I 2-I continuation 2 2-II 2-II continuation 2
63/60 A, without pilot contact	IP44	2-III 2-III continuation 1 2-IV 2-IV continuation 1
63/60 A and 125/100 A, without pilot contact	IP67 IP67/IP69 IP66/IP67 IP66/IP67/IP69	2-III 2-III continuation 2 2-IV 2-IV continuation 2
63/60 A, with pilot contact	IP44	2-IIIa 2-III continuation 1 2-IVa 2-IV continuation 1
63/60 A and 125/100 A, with pilot contact	IP67 IP67/IP69 IP66/IP67 IP66/IP67/IP69	2-IIIa 2-III continuation 2 2-IVa 2-IV continuation 2
Mechanical interlock for 16 A to 125 A accessories	IP44 IP67 IP67/IP69 IP66/IP67 IP66/IP67/IP69	2-V

For accessories having rated operating voltages not exceeding 50 V, Table 205 applies.

Table 205 – Accessories with rated operating voltages not exceeding 50 V

Accessory	Degree of protection	Standard sheet
16/20 A and 32/30 A	IP44	2-VIII 2-VIIIa 2-VIII continuation 1 2-IX 2-IXa 2-IX continuation 1
	IP67 IP67/IP69 IP66/IP67 IP66/IP67/IP69	2-VIII 2-VIIIa 2-VIII continuation 2 2-IX 2-IXa 2-IX continuation 2

For retaining devices, Table 206 applies.

Table 206 – Retaining devices

Rated current of the accessory A	Classification according to degree of protection against moisture	Socket-outlets			Plugs and appliance inlets		
		Retaining means	Standard sheet		Retaining means	Standard sheet	
			Rated operating voltage exceeding 50 V	Rated operating voltage not exceeding 50 V		Rated operating voltage exceeding 50 V	Rated operating voltage not exceeding 50 V
16/20 and 32/30	IP44	Lid	2-I (continuation 1)	2-VIII (continuation 1)	Lug or cavity	2-II (continuation 1)	2-IX (continuation 1)
	IP67 IP67/IP69 IP66/IP67 IP66/IP67/IP69	Two-ramp system	2-I (continuation 2)	2-VIII (continuation 2)	Lug or cavity and bayonet ring	2-II (continuation 2)	2-IX (continuation 2)
63/60	IP44	Lid and two-ramp system	2-III (continuation 1)	–	Lug or cavity	2-IV (continuation 1)	–
	IP67 IP67/IP69 IP66/IP67 IP66/IP67/IP69	Two-ramp system	2-III (continuation 2)	–	Bayonet ring	2-IV (continuation 2)	–
125/100	IP67 IP67/IP69 IP66/IP67 IP66/IP67/IP69 ^{a)}	Two-ramp system	2-III (continuation 2)	–	Bayonet ring	2-IV (continuation 2)	–

^{a)} When 125/100 A fixed socket-outlets are mounted on or integrated with enclosures, the whole unit can also be IP44.

Deviations from the dimensions specified in the standard sheets may be made, but only if they provide a technical advantage and do not adversely affect the purpose and safety of the accessories complying with the standard sheets, especially with regard to compatibility and non-compatibility.

Compliance is checked by means of gauges or by measurement for those dimensions not covered by gauges:

- *for accessories having rated operating voltages exceeding 50 V, in accordance with:*
 - *Figure 201 and Figure 202 for socket-outlets;*
 - *Figure 203 and Figure 204 for plugs and appliance inlets;*
- *for accessories having rated operating voltages not exceeding 50 V, in accordance with:*
 - *Figure 205 and Figure 206 for 16/20 A and 32/30 A accessories.*

The gauges shall be moved axially to the centre line of the accessory with a force as shown in the Table 207, applied for 1 min.

Table 207 – Forces applied to "GO"/"NO-GO" gauges

Rated operating voltage V	Rated current A		Force (max.) for "GO" gauge N	Force (max.) for "NO-GO" gauge $N_{(-1)}^0$
	Series I	Series II		
Not exceeding 50	16	20	150	30
	32	30	150	30
Exceeding 50	16	20	60	20
	32	30	90	30
	63	60	165	55
	125	100	240	80

Before the test, the test specimen of insulating material shall be stored at a temperature of (20 ± 5) °C and a relative humidity between 45 % and 75 % for four weeks.

For accessories having rated operating voltages not exceeding 50 V, the position of the minor key or keyway shall be as shown in Table 206 or Table 207.

For accessories having rated operating voltages exceeding 50 V, the position of the earthing contact shall be as shown in Table 208.

Compliance is checked by inspection.

Table 208 – General purpose accessories with rated operating voltage not exceeding 50 V

Rated operating voltage V	Frequency Hz	Minor key or keyway position ^{a)}
20 to 25	50 and 60	No minor key or keyway
40 to 50	50 and 60	12
20 to 25 and 40 to 50	100 up to and including 200	4
	300	2
	400	3
	Over 400 up to and including 500	11
	Direct current	10

^{a)} The minor key or keyway position is indicated by the relevant number (see 7.1).

Table 209 – Special application accessories with rated operating voltage not exceeding 50 V

Rated operating voltage	Rated current	Numbers of poles	Other characteristics and application	Minor key or keyway position ^{a)}
25 V	32 A	3	Portable electric incubators – use at 12 V DC or 24 V DC on ambulances or helicopters	8

^{a)} The minor key or keyway is indicated by the relevant number.

Positions 1 and 9 are reserved for future standardisation. For constructional reasons, positions 5, 6 and 7 cannot be used.

Table 210 – Positions of earthing contact

Number of contacts	Type	Frequency Hz	Rated operating voltage V	Accessories' earthing-contact position ^{a)}	
				16/20 A 32/30 A	63/60 A 125/100 A
3 contacts	1P+N+E Series II	50 and 60	100 to 130	4	4
		60	277	5	5
	2P+E Series I and II	50 and 60	100 to 130	4	4
			200 to 250	6	6
		50 and 60	380 to 415	9	9
			480 to 500	7	7
			Supply from an isolating transformer	12	12
		100 up to and including 300	Over 50	10	10
		Over 300 up to and including 500	Over 50	2	2
	DC	Over 50 up to and including 250 ^{d)}	3	3	
		Over 250	8	8	

Number of contacts	Type	Frequency Hz	Rated operating voltage V	Accessories' earthing-contact position ^{a)}	
				16/20 A 32/30 A	63/60 A 125/100 A
4 contacts	2P+N+E Series II	50 and 60	125/250 single-phase	12	12
	Series I	50 and 60	Supply from an isolating transformer	12	12
	3P+E Series I and II	50 and 60	100 to 130	4	4
			200 to 250	9	9
			380 to 415	6	6
		60	440 to 460 ^{b)}	11	11
		50 and 60	480 to 500	7	7
			600 to 690	5	5
		50 60	380 440 ^{c)}	3	3
		50 and 60	1 000	8	8
100 up to and including 300	Over 50	10	10		
Over 300 up to and including 500	Over 50	2	2		
5 contacts	3P+N+E Series I and II	50 and 60	57/100 to 75/130	4	4
			120/208 to 144/250	9	9
			200/346 to 240/415	6	6
			277/480 to 288/500	7	7
			347/600 to 400/690	5	5
		60	250/440 to 265/460 ^{b)}	11	11
		50 60	220/380 250/440 ^{c)}	3	3
5 contacts (continued)	3P+N+E Series I and II (continued)	50 and 60	1 000	8	8
		50 and 60	Supply from an isolating transformer	12	12
		100 up to and including 300	Over 50	10	10
		Over 300 up to and including 500	Over 50	2	2
All types		All rated operating voltages and/or frequencies not covered by other configurations. This clock position can additionally be used in special applications where a distinction to standardized positions is needed	1	1	

NOTE The positions shown by a dash (–) are not standardized.

^{a)} The earthing-contact position is indicated by the relevant numeral (see 7.1).

^{b)} Mainly for marine installations.

^{c)} Only for refrigerated containers (standardized ISO).

^{d)} This configuration is required to have an earthing contact because it covers voltages above the upper limits of ELV (DC) according to IEC 60364-4-41.

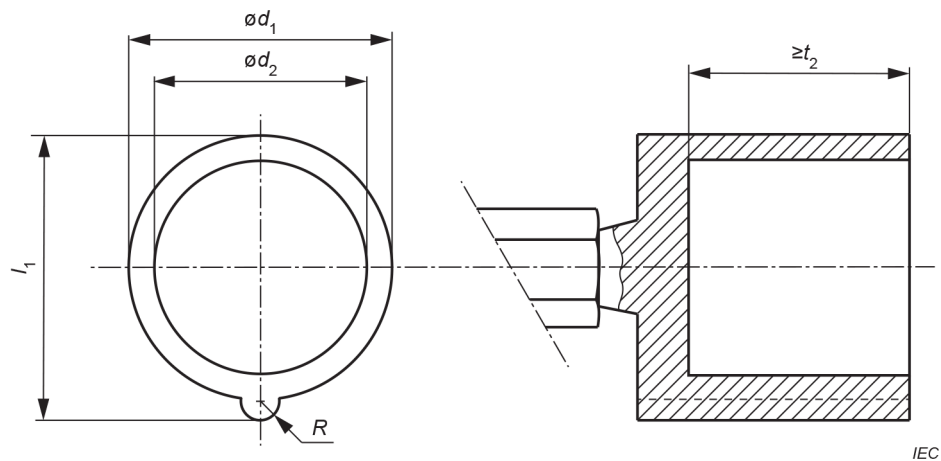

The eccentricity between the centres of d_1 and d_2 shall not exceed 0,05 mm.

Type	d_1 0 -0,05	d_2 +0,05 0	l_1 0 -0,05	R 0 -0,025	t_2 Min.
16/20 A – 2P + E	44,3	36,0	47,5	3,3	38
16/20 A – 3P + E	50,4	40,8	54,0	3,3	38
16/20 A – 3P + N + E	57,3	46,4	61,3	3,3	38
32/30 A – 2P + E, 3P + E	58,6	47,0	64,6	3,3	48
32/30 A – 3P + N + E	64,7	52,9	71,2	3,3	48
63/60 A	71,0	60,0	77,5	4,8	69
125/100 A	83,0	71,0	89,5	4,8	76

Dimensions in millimetres

(See 4.201)

It shall be possible to insert the appropriate gauge into the socket-outlet.

Figure 201 – 16/20 A, 32/30 A, 63/60 A and 125/100 A socket-outlets having rated operating voltages exceeding 50 V – "go" gauges for checking dimensions d_1 , d_2 , l_1

Dimensions in millimetres

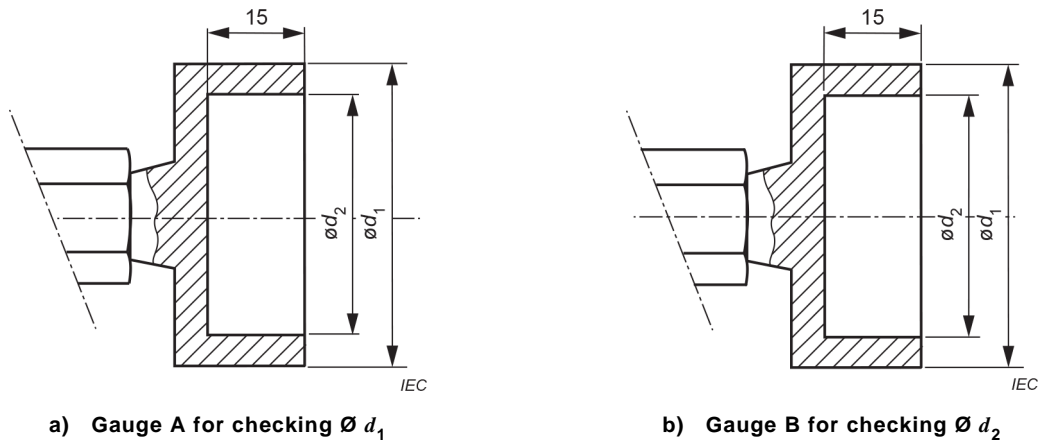

Type	Gauge A		Gauge B	
	d_1 +0,05 0	d_2 +0,5 0	d_1 0 -0,5	d_2 0 -0,05
16/20 A – 2P + E	44,73	37,0	43,3	34,47
16/20 A – 3P + E	50,93	41,8	49,4	39,27
16/20 A – 3P + N + E	57,93	47,4	56,3	44,87
32/30 A – 2P + E, 3P + E	59,23	48,0	57,6	45,47
32/30 A – 3P + N + E	65,33	53,9	63,7	51,37
63/60 A	71,83	61,0	70,0	58,47
125/100 A	83,83	72,0	82,0	69,47

Dimensions in millimetres

(See 4.201)

It shall not be possible to insert gauges A and B into the socket-outlet.

Figure 202 – 16/20 A, 32/30 A, 63/60 A and 125/100 A socket-outlets having rated operating voltages exceeding 50 V – "no-go" gauges for checking dimensions d_1, d_2

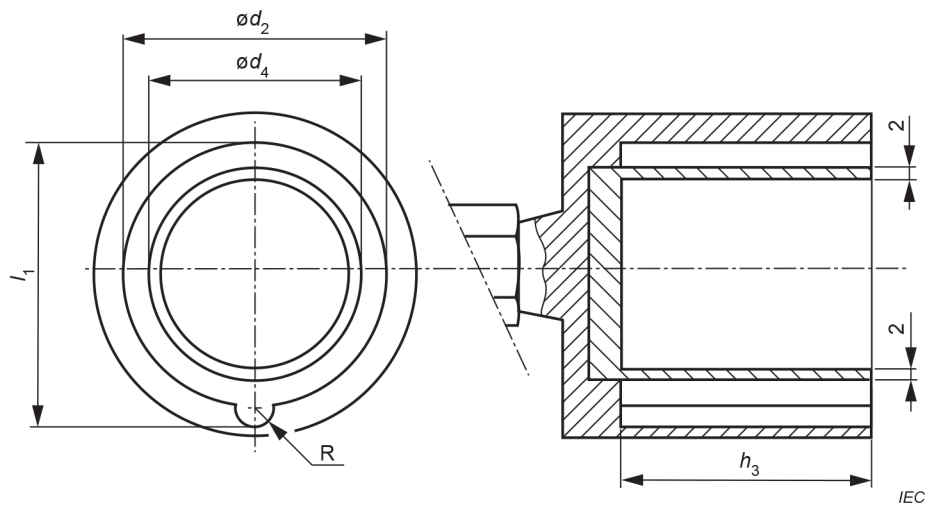

The eccentricity between the centres of d_2 and d_4 shall not exceed 0,05 mm.

Type	Gauge					R +0,25 0
	d_2	d_4 +0,05 0	h_3	l_1 +0,05 0		
				a)	b)	
16/20 A – 2P + E	43,5	37,9	37,05	46,5	47,0	3,2
16/20 A – 3P + E	49,5	42,8	37,05	52,9	53,6	3,2
16/20 A – 3P + N + E	56,1	48,8	37,05	60,1	61,0	3,2
32/30 A – 2P + E, 3P + E	57,3	49,7	46,05	63,2	63,2	3,2
32/30 A – 3P + N + E	63,4	55,6	46,05	69,9	69,9	3,2
63/60 A	69,5	61,5	67,05	75,5		4,2
125/100 A	81,5	72,5	75,55	87,5		4,2
a) For accessories with metal enclosures.						
b) For accessories with enclosures of insulating material.						

Dimensions in millimetres

(See 4.201)

It shall be possible to insert the appropriate gauge into the plug or appliance inlet.

Figure 203 – 16/20 A, 32/30 A, 63/60 A and 125/100 A plugs and appliance inlets having rated operating voltages exceeding 50 V – "go" gauges for checking dimensions d_2 , d_4 , l_1

Dimensions in millimetres

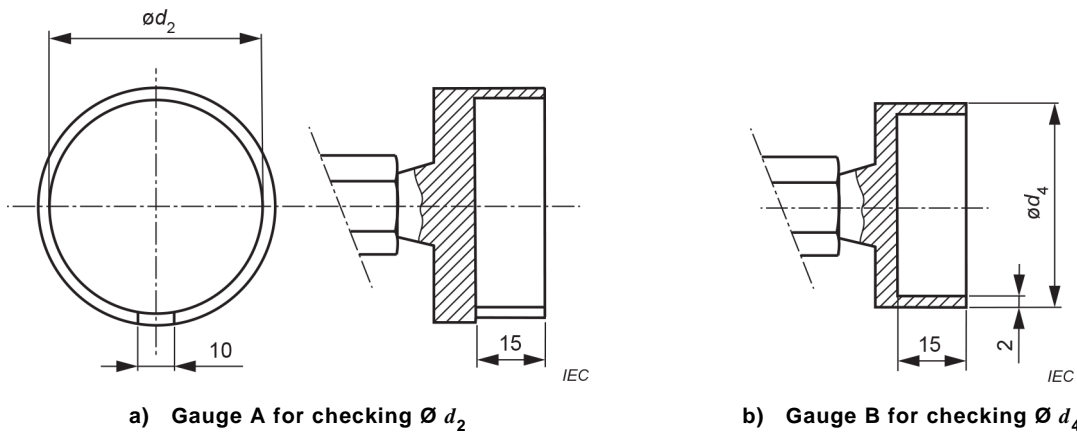

Type	Gauge A	Gauge B	
	d_2	d_4	
	0 -0,05	+0,05 0	
		Accessories with metal enclosures	Accessories with enclosures of insulating material
16/20 A – 2P + E	42,87	39,83	39,43
16/20 A – 3P + E	48,87	44,73	44,33
16/20 A – 3P + N + E	55,47	50,73	50,33
32/30 A – 2P + E, 3P + E	56,47	51,63	51,33
32/30 A – 3P + N + E	62,57	57,53	57,23
63/60 A	68,67	63,53	
125/100 A	80,67	75,03	

Dimensions in millimetres

(See 4.201)

It shall not be possible to insert gauges A and B into the plug or appliance inlet.

Figure 204 – 16/20 A, 32/30 A, 63/60 A and 125/100 A plugs and appliance inlets having rated operating voltages exceeding 50 V – "NO-GO" gauges for checking dimensions d_2 , d_4

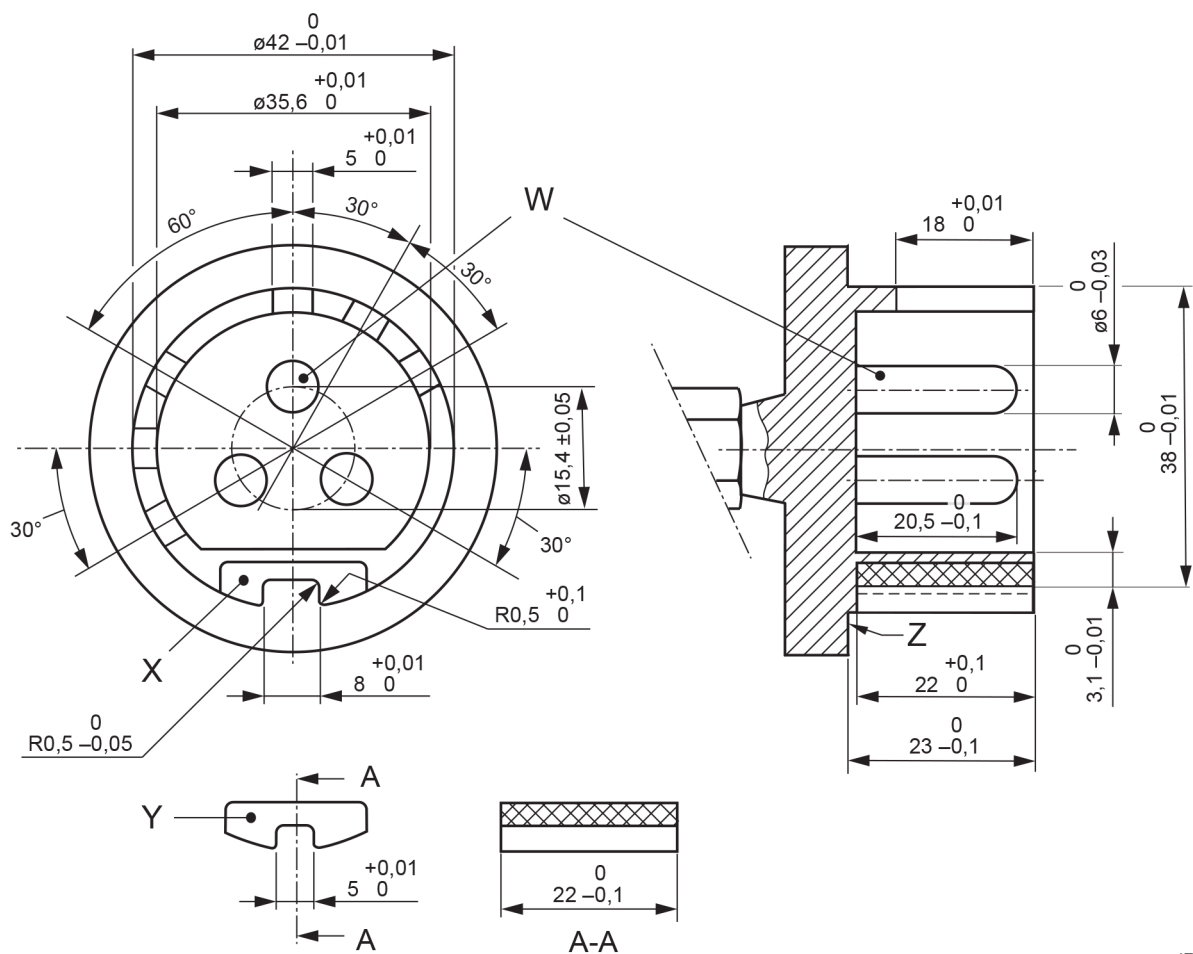

IEC

Key

- W Removable pin for three-pole gauge
- X Insert for gauge 16/20 A
- Y Insert for gauge 32/30 A
- Z Stop surface

It shall be possible to insert the appropriate gauge into the socket-outlet so that the stop surface of the gauge comes into contact with the front surface of the shroud of the socket-outlet.

Figure 205 – 16/20 A and 32/30 A socket-outlets having rated operating voltages not exceeding 50 V – Gauges for checking compatibility

Dimensions in millimetres

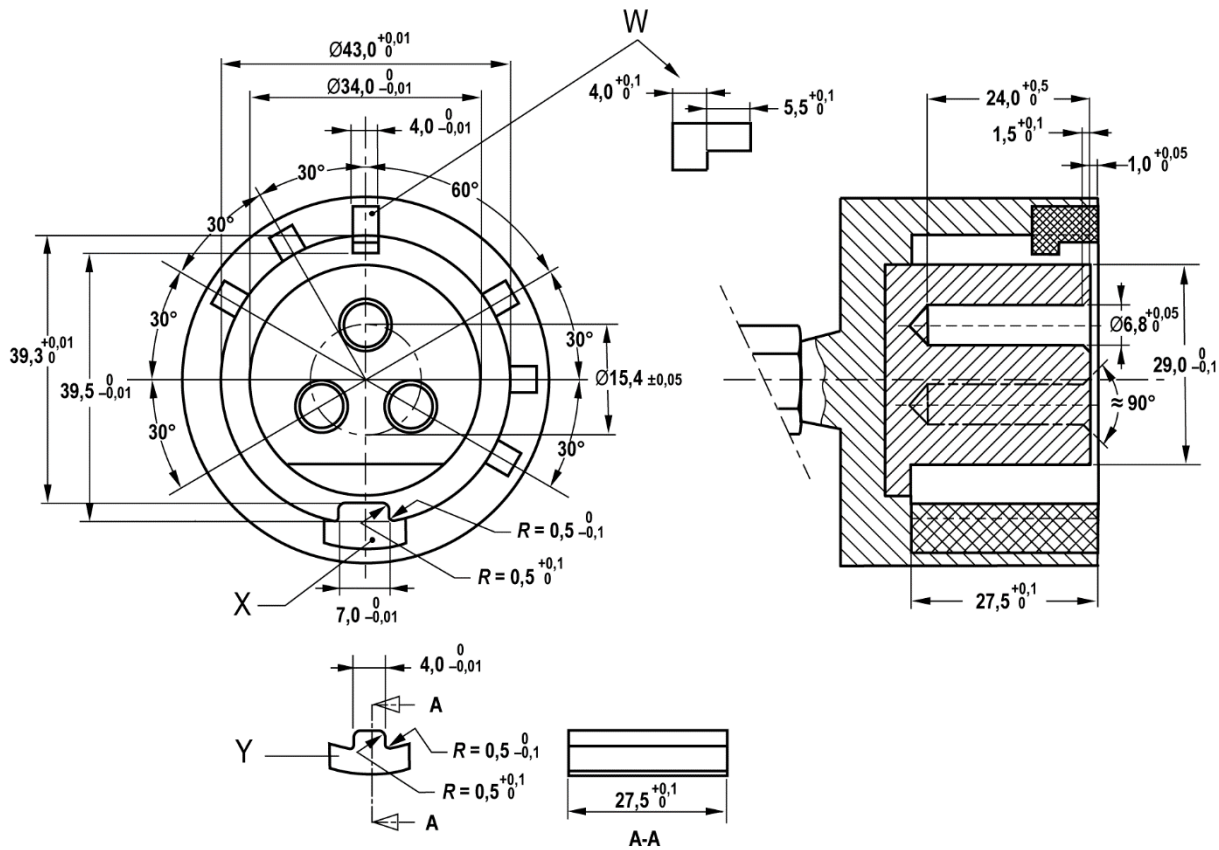
**Key**

W Insert to be used for the various positions of the minor key

X Insert for gauge 16/20 A

Y Insert for gauge 32/30 A

It shall be possible to insert the appropriate gauge, without undue force, into the plug or appliance inlet so that the front surface of the gauge comes into contact with the stop surface of the plug or appliance inlet.

**Figure 206 – 16/20 A and 32/30 A plugs and appliance inlets
having rated operating voltages not exceeding 50 V –
Gauges for checking compatibility**

8.2 Replace the existing text with the following:

8.2.1 General

For accessories having rated operating voltages exceeding 50 V, it shall not be possible to engage:

- plugs with fixed or portable socket-outlets having different ratings or having different contact combinations;
- portable socket-outlets with appliance inlets or plugs having different ratings or having different contact combinations.

In addition, for all accessories the design shall be such that improper connections shall not be possible between:

- the earth and/or pilot plug-contact and a live socket-contact, or a live plug-contact and the earth and/or pilot socket-contact;
- the phase plug-contacts and the neutral socket-contact, if any;

- the neutral plug-contact and a phase socket-contact.

Compliance is checked by inspection, with the following exception:

For the two last dashed list items above, compliance is not required between the three contact accessories of Series I and Series II, 4 h, since these have reciprocal contact positions.

NOTE These conflicting versions have both been in use for many years and resolution of this problem has been found to be impractical.

It shall not be possible to engage plugs with socket-outlets having different earthing-contact positions or minor key positions.

Compliance is checked by inspection and tests using the methods indicated in 8.2.2 for plugs and inlets and 8.2.3 for socket outlets. These tests are made after storage of test specimens of insulating material at a temperature of (20 ± 5) °C and with relative humidity between 45 % and 75 % for four weeks.

For accessories having thermoplastic housing, this test is made at a temperature of (35 ± 2) °C, both the accessories and the gauges being at this temperature.

8.2.2 Checking plugs and appliance inlets

8.2.2.1 General

For plugs and appliance inlets with rated operating voltage exceeding 50 V, gauges according to Figure 207 are used.

For plugs and appliance inlets with rated operating voltage not exceeding 50 V, gauges according to Figure 208 are used.

8.2.2.2 First test (key)

The socket-gauge shown in Figure 207 is placed before the plug in such a way that during the test the key shall hit the lower part of the shroud of the gauge approximately in the middle.

The force F is slowly increased in such a way that the total force given in Table 209 is exerted after 15 s. After that the full force is applied for 1 min.

Table 211 – Test forces

Rated current Series I/II	A	16/20	32/30	63/60	125/100
Force F	N	175	210	385	560

When the force is applied, the gauge is not permitted to move more than 4 mm in relation to the shroud of the plug or appliance inlet.

After the test, the plug and appliance inlet shall not be damaged in such a way that impairs further use of the accessory.

These forces are equal to 1,4 times the corresponding withdrawal forces.

Dimensions in millimetres

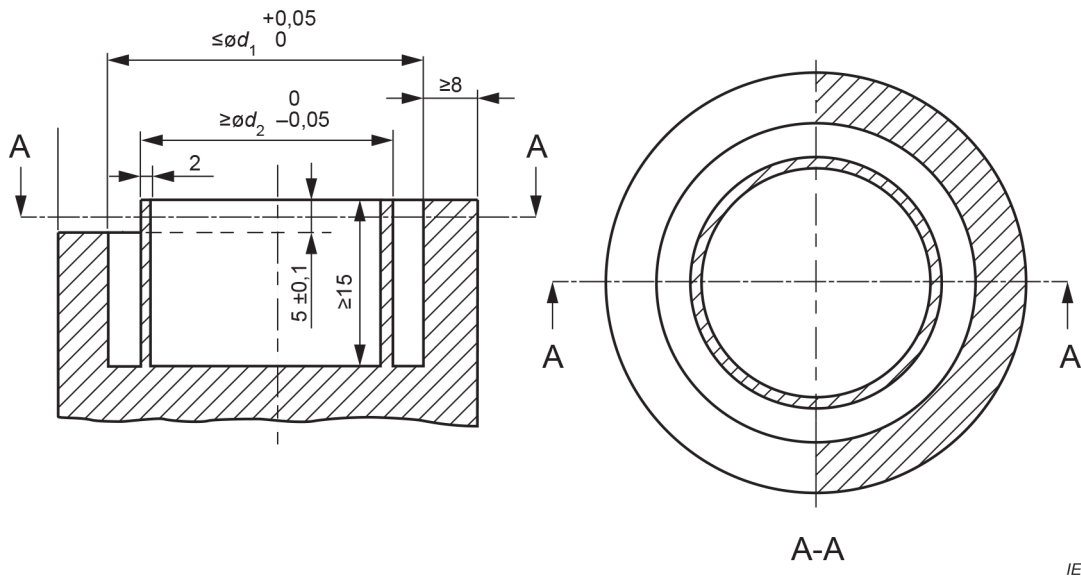

IEC

The dimensions d_1 and d_2 are those of the corresponding socket-outlets.

Figure 207 – "NO-GO" gauges for checking 16/20 A, 32/30 A, 63/60 A and 125/100 A plugs and appliance inlets having rated operating voltages exceeding 50 V

Dimensions in millimetres

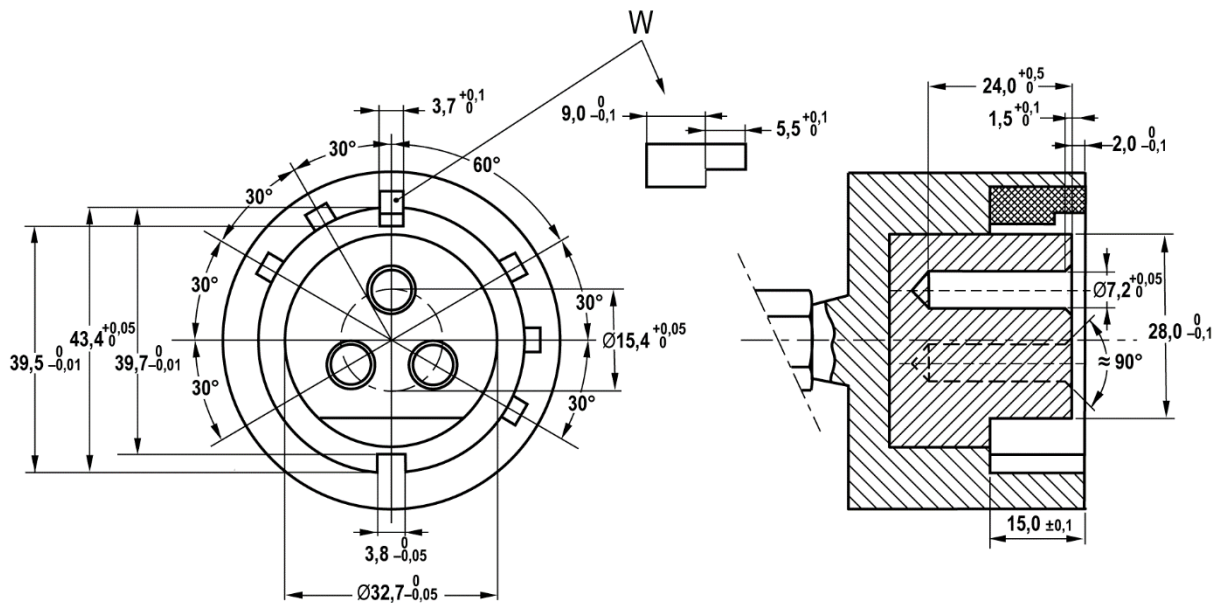

Key

W Insert to be used for the various positions of the minor key

In any position of the insert, it shall not be possible to pass the gauge in the correct position over the shroud of the plug or appliance inlet.

Figure 208 – 16/20 A and 32/30 A plugs and appliance inlets having rated operating voltages not exceeding 50 V – Gauges for checking rigidity of enclosures of thermoplastic material under humid and warm conditions

8.2.2.3 Second test (earth pin and pins that are not solid)

The force F shall be applied to:

- *the earth pin; and*
- *pins that are not solid,*

in the same manner and for the same duration as in the first test (key).

After this test, the plug and appliance inlet shall comply with the relevant standard sheet.

8.2.2.4 Third test (pins that are not solid):

A force of 100 N is exerted on the pin, which is supported over its entire length as shown in Figure 209, for 1 min in a direction perpendicular to the axis of the pin, by the means of a steel rod having a diameter of 4,8 mm, the axis of which is also perpendicular to the axis of the pin.

The test is performed three times, once at $\frac{1}{4}$ and $\frac{1}{2}$ and $\frac{3}{4}$ of the length the pin, the relevant pins being as follows:

- h_2 and h_3 of standard sheet 2-II;
- h_2 of standard sheet 2-IV;
- h_2 and h_5 of standard sheet 2-IVa;
- dimension of the pin 20,5 (0, -1) mm of standard sheets 2-IX and 2-IXa.

The test is repeated by rotating the pin every 45° over its axis.

During the application of the force, the reduction of the dimension of the pin at the point where the force is applied shall not exceed 0,15 mm.

After removal of the rod, the dimensions of the pin shall not have changed by more than 0,06 mm in any direction.

For this test the pin may be removed from the contact carrier.

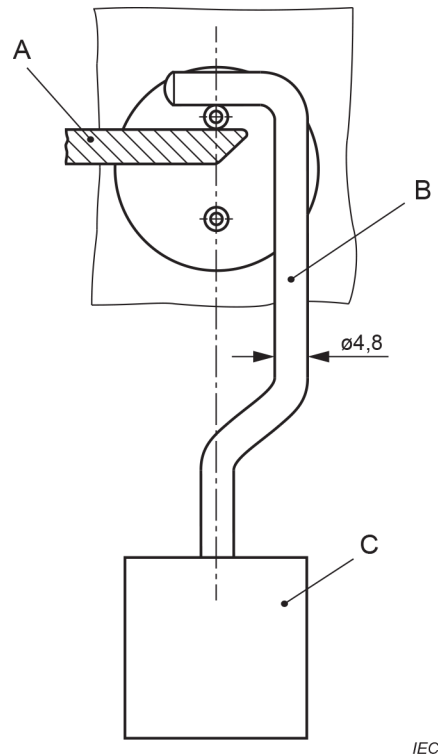

IEC

Key

- A Support
- B Steel rod
- C Weight

It shall be possible to insert the appropriate gauge, without undue force, into the plug or appliance inlet so that the front surface of the gauge comes into contact with the stop surface of the plug or appliance inlet.

Figure 209 – Device for testing non-solid pins

8.2.3 Checking socket-outlets

8.2.3.1 General

For socket-outlets having rated operating voltages exceeding 50 V, gauges according to Figure 210 are used.

For socket-outlets having rated operating voltages not exceeding 50 V, gauges according to Figure 212 are used.

8.2.3.2 First test (shroud)

The first test is carried out in all different clock positions, except for the one corresponding to the position of the socket-outlet to be used.

The test specimen shall be fixed and supported in such a way that the rigidity of the socket-outlet is not influenced.

Arrangement for the test shall be according to Figure 211.

The gauge shown in Figure 211 shall hit two opposite points of the accessory at the same time. The axis of the gauge and of the accessory shall be approximately parallel and the chamfer shall be equally divided in both sides.

The force F is slowly increased in such a way that the total force given in Table 209 is exerted after 15 s. After that the full force is applied for 1 min.

When the force is applied, the gauge is not permitted to move more than 4 mm in relation to the shroud of the socket-outlet.

After the test, the socket-outlet shall not be damaged to the extent of impairing the further use of the accessory.

8.2.3.3 Second test (phase holes)

For the second test, the gauge shown in Figure 213 is inserted in each phase hole.

The gauge shall not enter the phase hole to an extent greater than the distance shown in Table 210 measured from the front of the internal part (see Figure 214).

The same forces and duration and the same method of application are used as for the first test (shroud).

Table 212 – Maximum displacement of the gauges

Rated current Series I/II	A	16/20	32/30	63/60	125/100
Distance X	mm	11	12,5	15	20

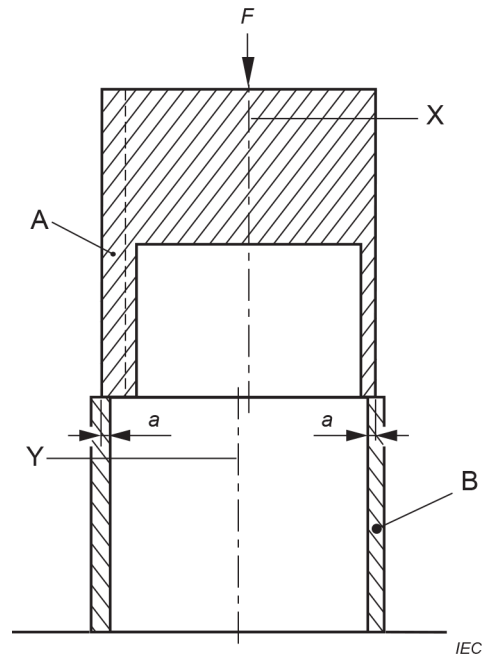

(See 4.201)

Key

- A Gauge for checking socket-outlet
- B Socket-outlet
- X Gauge centre line
- Y Centre line of socket-outlet

Figure 210 – Arrangement for test using "NO-GO" gauge for checking 16/20 A, 32/30 A, 63/60 A and 125/100 A socket-outlets having rated operating voltages exceeding 50 V

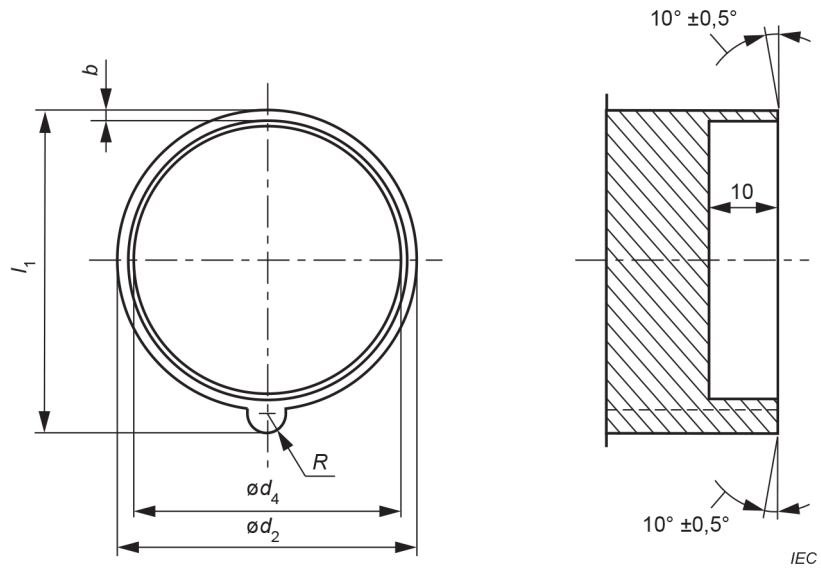

(See 4.201)

The eccentricity between the centres of d_2 and d_4 shall not exceed 0,05 mm.

Type	Gauge				
	d_2	d_4	l_1	b	R
	0 -0,05	+0,1 0	0 -0,05	±0,1	0 -0,1
16/20 A – 2P + E	42,9	39,4	46,1	1,4	2,8
16/20 A – 3P + E	48,9	44,3	52,4	1,5	2,8
16/20 A – 3P + N + E	55,5	50,3	59,5	1,6	2,8
32/30 A – 2P + E, 3P + E	56,5	51,3	62,6	2,5	2,8
32/30 A – 3P + N + E	62,6	57,2	69,2	2,7	2,8
63/60 A	68,7	63,5	74,9	2,45	3,8
125/100 A	80,7	75,0	86,9	2,45	3,8

Dimensions in millimetres

Figure 211 – Gauges for checking socket-outlets of 16/20 A, 32/30 A, 63/60 A and 125/100 A having rated operating voltages exceeding 50 V

Dimensions in millimetres

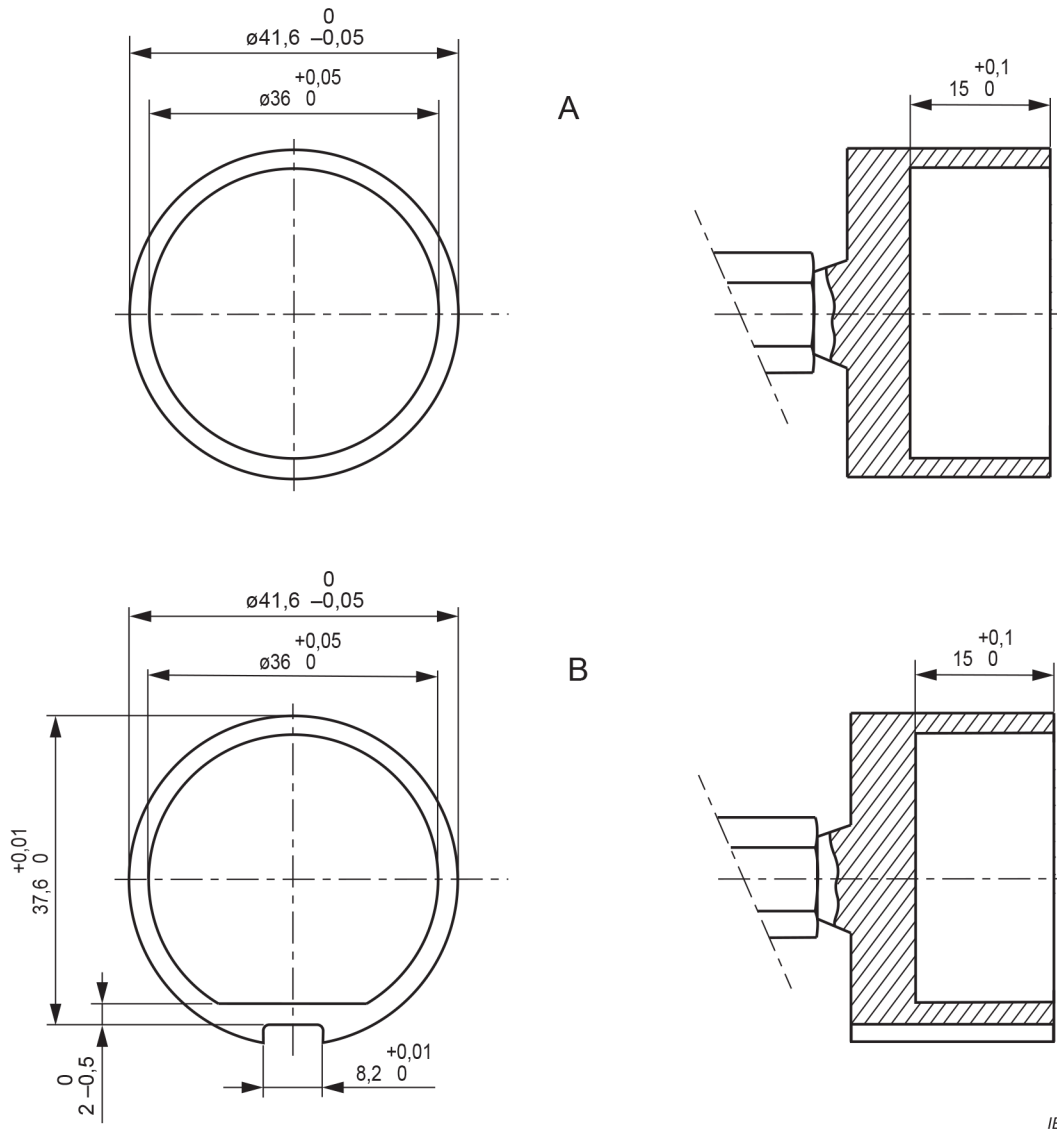

IEC

Key

A Gauge A

B Gauge B

It shall not be possible to insert gauge A into the socket-outlet.

It shall not be possible to insert gauge B in the correct position into the shroud of the socket-outlet.

Figure 212 – 16/20 A and 32/30 A socket-outlets having rated operating voltages not exceeding 50 V – Gauges for checking rigidity of enclosures of thermoplastic material under humid and warm conditions

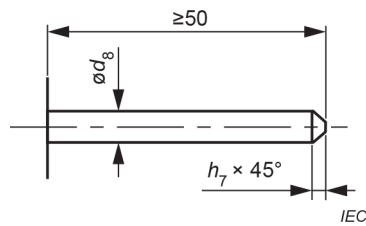

Type		Gauge	
		d_8	h_7
		0 -0,03	+0,1 0
16/20 A	2P + E	6,91	2,2
	3P + E	6,91	2,2
	3P + N + E	6,91	2,2
32/30 A	2P + E, 3P + E	7,91	2,5
	3P + N + E	7,91	2,5
63/60 A	All	9,89	3
125/100 A	All	11,89	4

Dimensions in millimetres

Figure 213 – Gauge for checking phase holes

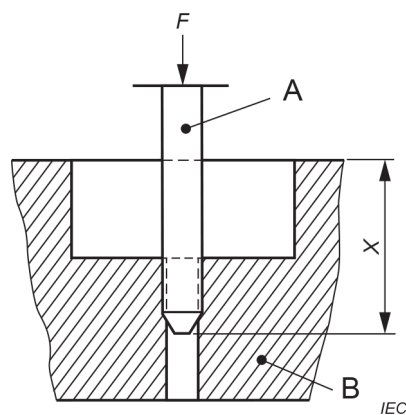

Key

- A Pin gauge
- B Main part in socket-outlet

Figure 214 – Test of phase hole

8.3 Replace the existing compliance statement with the following:

Compliance is checked by manual test and, for accessories with enclosures of resilient or thermoplastic material, by means of the gauge shown in Figure 215.

The gauge is applied with a force of 200 N for 1 min. For accessories with enclosures of thermoplastic material the gauge is applied at a temperature of $(35 \pm 2)^\circ\text{C}$, both the accessories and the gauge being at this temperature.

For accessories of rigid material, such as metal, thermosetting resins, ceramic material and the like, conformity to the relevant standard sheets ensures compliance with this requirement.

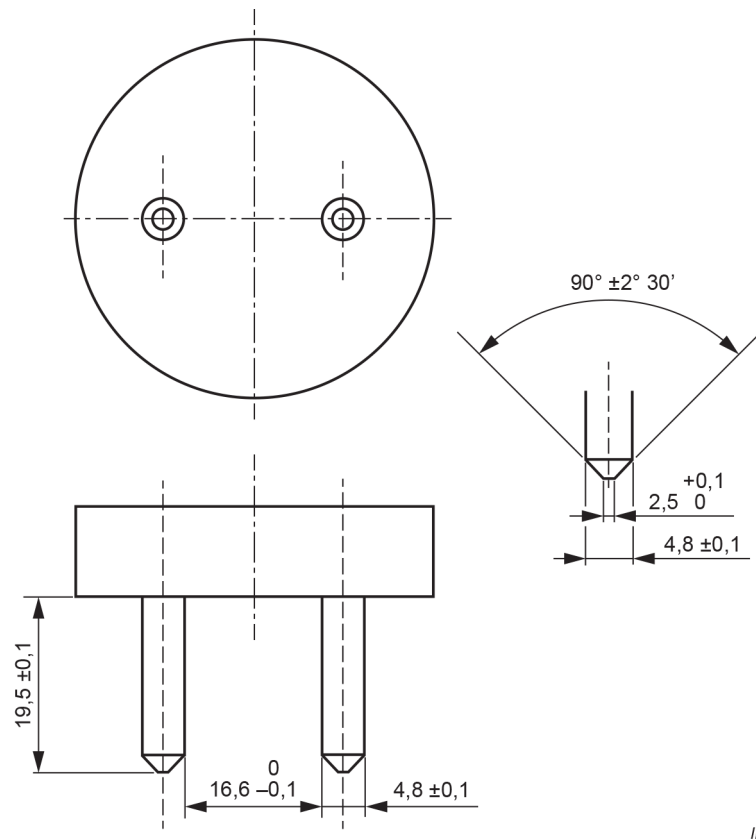

It shall not be possible to touch a phase contact tube of the socket-outlet with one pin of the gauge.

Figure 215 – Socket-outlets with enclosures of resilient or thermoplastic material – Gauge for checking impossibility of single-pole insertion of a 10/16 A 250 V two-pole plug

9 Protection against electric shock

Clause 9 of IEC 60309-1:2021 applies except as follows:

9.1 Add at the end of the subclause:

Conformity with the relevant standard sheets ensures compliance with the requirement as far as inaccessibility of contacts during insertion of a plug or portable socket-outlet into the complementary accessories is concerned.

9.2 Add at the end of the subclause:

Conformity with the relevant standard sheets ensures compliance with these requirements.

10 Provision for earthing

Clause 10 of IEC 60309-1:2021 applies.

11 Terminals and terminations

Clause 11 of IEC 60309-1:2021 applies except as follows:

Replace Table 3 of IEC 60309-1:2021 with the following new Table 3:

Table 3 – Size of connectable conductors

Rating of the accessory		Internal connection ^{a)}					External earthing connection if any	
Rated operating voltage V	Current A		Flexible cables for plugs and portable socket-outlets ^{b)}		Solid or stranded cables for fixed socket-outlets ^{b) d)}			
			Solid or stranded cables for appliance inlets ^{b)}					
	Series I	Series II	Series I mm ²	Series II AWG/MCM ^{c)}	Series I mm ²	Series II AWG/MCM ^{c)}	Series I mm ²	Series II AWG/MCM ^{c)}
Not exceeding 50	16	20	4 to 10	12 to 8	4 to 10	12 to 8		
	32	30	4 to 10	12 to 8	4 to 10	12 to 8		
Exceeding 50	16	20	1 to 2,5	16 to 12	1,5 to 4	16 to 12	6	10
	32	30	2,5 to 6	14 to 10	2,5 to 10	14 to 8	10	8
	63	60	6 to 16	10 to 6	6 to 25	10 to 4	25	4
	125	100	16 to 50	6 to 2	25 to 70	4 to 0	25	4

^{a)} Terminals for pilot conductors, if any, shall allow the connection of conductors having the same nominal cross-sectional areas as the terminals of 16 A accessories having rated operating voltages exceeding 50 V.

^{b)} Classification of conductors: according to IEC 60228:1978, Clause 2, solid (Class 1); stranded (Class 2); flexible (Class 5).

^{c)} The nominal cross-sectional areas of conductors are given in square millimetres (mm²). AWG/MCM values are considered as equivalent to mm² for the purpose of this document.

AWG: American Wire Gauge is a system of identifying wires in which the diameters are in geometric progression between size 36 and size 0000.

MCM: Mille Circular Mills denotes circle surface unit area. 1 MCM = 0,506 7 mm².

^{d)} For socket-outlets declared for flexible conductors only, these values apply.

The terminals are then fitted with conductors of the smallest and largest cross-sectional areas specified in Table 3, rigid (solid or stranded) for fixed socket-outlets and appliance inlets, and flexible for plugs and portable socket-outlets; the terminal screws are tightened, the maximum torque applied being equal to two-thirds of the torque specified in Table 19. Each conductor is subjected to a pull force N of the value, in newton, shown in Table 213; the pull is applied without jerks, for 1 min, in the direction of the axis of the conductor space.

Table 213 – Pulling force on terminals

Terminal size	2	3	4	5	6	7	8	9	10
Pulling force N	50	50	60	80	90	100	120	150	200

During the test, the conductor shall not move noticeably in the terminal.

NOTE For terminals with sizes from 8 to 10, the value of the pulling force N is provisional.

12 Interlocks

Clause 12 of IEC 60309-1:2021 applies.

13 Resistance to ageing of rubber and thermoplastic material

Clause 13 of IEC 60309-1:2021 applies.

14 Construction

Clause 14 of IEC 60309-1:2021 applies except as follows:

14.2.2 *Replace the existing text with the following:*

The pressure exerted by the contact tubes on the pins of a plug shall not be so great as to prevent easy insertion and withdrawal of the plug.

Compliance is checked by determining the force necessary to withdraw the test plug from the sample, this being mounted so that the axes of the contact tubes are vertical with the contact opening downwards, as shown in Figure 216.

A test plug provided with pins having the dimensions shown in Table 212 is inserted into the sample.

Table 214 – Diameter of pins of the test plug

Nominal pin diameter mm	Diameter of pins of the test plug mm $\begin{matrix} +0,01 \\ 0 \end{matrix}$
5	5,00
6	6,00
7	7,00
8	8,00
10	10,00
12	12,00

The principal weight, together with the supplementary weight (the latter being such that it exerts a force equal to one-tenth of the force exerted by the principal weight) and the test plug, exert a force equal to the maximum withdrawal force shown in Table 213.

The principal weight is hung without jolting on the test plug, and the supplementary weight is allowed to fall from a height of 50 mm onto the principal weight.

The plug shall not remain in the sample.

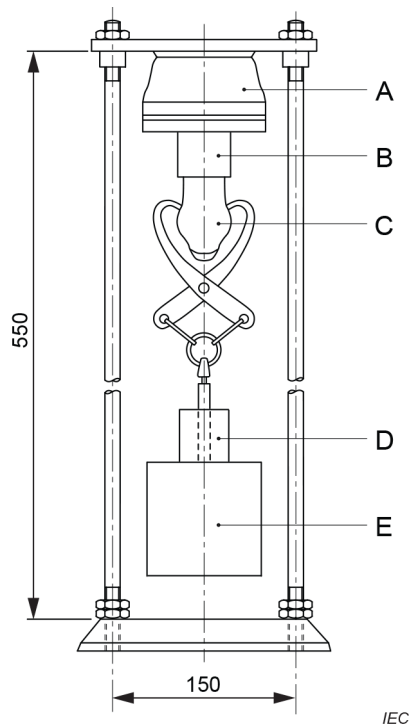

Key

- A Support
- B Sample
- C Test plug
- D Supplementary sliding weight
- E Principal weight

Figure 216 – Example of apparatus for checking the withdrawal force

Table 215 – Maximum withdrawal forces

Rated current A		Maximum withdrawal force
Series I	Series II	N
16	20	150
32	30	150
63	60	275
125	100	400

NOTE Details of the test plugs are under consideration.

14.2.4 *Replace the existing text with the following:*

Contact tubes shall be self-adjusting and so designed as to ensure adequate contact continuity before and after a number of operations corresponding to their operational life.

Contact tubes other than the earth-contact shall be floating.

Earth contact tubes need not be floating, provided that they have the necessary resilience in all directions.

Compliance is checked by inspection and by the following test:

The sample is mounted so that the axes of the contact tubes are vertical with the contact openings downwards.

A gauge of hardened steel, with a finish of 0,002 mm and free from grease, having the dimensions shown in Table 214, is inserted into each contact tube, also free from grease, and the force necessary to withdraw the gauge is measured.

The sum of the force and the weight of the gauge shall exceed the minimum total force shown in Table 214.

Table 216 – Withdrawal forces

Nominal pin diameter	Gauge	
	Diameter of gauge	Minimum total force
mm	+0 mm -0,01	N
5	4,80	2,5
6	5,80	5
7	6,80	5
8	7,80	10
10	9,80	15
12	11,80	20

Additional subclauses:

14.201 Phase inverter

It shall not be possible to operate the phase inverting means unintentionally or to operate the phase inverting means when the phase inverter is inserted in the complementary accessory.

The phase inverting means shall incorporate a latching means to retain it in its defined position.

Compliance is checked by inspection and manual test.

The operation of the phase inverting means shall not damage the cable or wiring.

Compliance is checked by inspection and by the test of Clause 21.

14.202 Solid pin

Solid pins shall be made of a single homogenous material without any intentional hole, slot, slit or the like.

This requirement is applicable for the pin parts described by:

- h_2 and h_3 of standard sheet 2-II;
- h_2 of standard sheet 2-IV;
- h_2 and h_5 of standard sheet 2-IVa;
- dimension of the pin 20,5 (0, -1) of standard sheets 2-IX and 2-IXa.

Compliance is checked by inspection.

15 Construction of fixed socket-outlets

Clause 15 of IEC 60309-1:2021 applies except as follows:

15.5 *Replace the fourth paragraph with the following:*

Fixed socket-outlets with a degree of protection up to and including IP44 and designed for only one mounting position, shall have provision for opening a drain hole at least 5 mm in diameter, or 20 mm² in area with a width of at least 3 mm, which is effective when the fixed socket-outlet is in the mounting position.

Additional subclause:

15.201 When 125/100 A fixed socket-outlets are mounted on or integrated with enclosures, the whole unit can be IP44.

16 Construction of plugs and portable socket-outlets

Clause 16 of IEC 60309-1:2021 applies except as follows:

16.1 *Replace the third paragraph with the following:*

Accessories shall be so designed that they can only be reassembled so as to ensure the correct angular relationship between key(s), keyway(s), the earthing pin and the earthing-contact tube, as originally assembled.

Add the following at the end of the subclause:

The tests to be carried out are those described in 15.1 and 15.2.

Additional subclause:

16.201 Plugs rated up to 32 A may incorporate a phase inverting means. These plugs shall comply with the general requirements for plugs and with Clause 21 for phase inverters. They shall be delivered with an instruction sheet with the following information:

Use class 5 or class 6 flexible conductors only, in accordance with IEC 60228 and make sure that the conductors can move to permit operation of the phase inverting means.
--

An integral switching device shall not be used as a phase inverting means.

The phase inverting means shall be preconditioned when wired with class 5 cables according to Clause 23 by carrying out 1 000 position changing operations.

17 Construction of appliance inlets

Clause 17 of IEC 60309-1:2021 applies except as follows:

Additional subclause:

17.201 Appliance inlets rated up to 32 A may incorporate a phase inverting means. These inlets shall comply with the general requirements for inlets and Clause 21 for phase inverters. They shall be delivered with an instructions sheet with the following information:

Use class 5 or class 6 flexible conductors only, in accordance with IEC 60228 and make sure that the conductors can move to permit operation of the phase inverting means.

For appliance inlets, switches can be used as phase inverting means. Switches shall comply with IEC 60947-3 in a utilisation category of at least AC-22A.

The phase inverting means shall be preconditioned when wired with class 5 conductors according to Clause 23, by carrying out 1 000 position changing operations.

18 Degrees of protection

Clause 18 of IEC 60309-1:2021 applies.

19 Insulation resistance and dielectric strength

Clause 19 of IEC 60309-1:2021 applies except as follows:

19.1 *Add the following after the third paragraph:*

For phase inverters, the testing is carried out with the phase inverting means in each of the end positions.

19.6 *Replace the existing text with the following:*

Immediately after the test of 19.5 it shall not be possible to engage accessories with enclosures of thermoplastic material with gauges having an earthing-contact position or a minor key or keyway position different from that of the sample.

For socket-outlets having rated operating voltages exceeding 50 V, the gauges shown in Figure 211 are used. For plugs and appliance inlets having rated operating voltages exceeding 50 V, the gauges shown in Figure 207 are used.

For 16/20 A and 32/30 A socket-outlets having rated operating voltages not exceeding 50 V, the gauges shown in Figure 212 are used. For plugs and appliance inlets having rated operating voltages not exceeding 50 V, the gauges shown in Figure 208 are used.

The gauges are applied with a force of 200 N applied for 1 min.

20 Breaking capacity

Clause 20 of IEC 60309-1:2021 applies except as follows:

Add the following after the first paragraph:

For the test on socket-outlets, plugs with solid pins shall be used.

Plugs and appliance inlets with solid pins complying with this document are not to be tested.

21 Normal operation

Clause 21 of IEC 60309-1:2021 applies except as follows:

Add the following after second paragraph:

For tests on socket-outlets, plugs with solid pins shall be used.

Plugs and appliance inlets with solid pins complying with this document shall not be tested.

Phase inverters are to be tested without load. The phase inverter shall be tested in each position for half of the number of cycles.

The wires of the cable shall not be twisted or damaged or show harmful alterations of cable insulation or broken strands in wires. The inverting means shall remain functional.

Compliance is checked by inspection.

22 Temperature rise

Clause 22 of IEC 60309-1:2021 applies except as follows:

Add the following after the second paragraph:

Phase inverters are to be tested in each of the end positions.

23 Flexible cables and their connection

Clause 23 of IEC 60309-1:2021 applies except as follows:

23.1 *Add the following after the third paragraph:*

Cable anchorages shall be of insulating material or be provided with an insulating lining fixed to the metal parts.

24 Mechanical strength

Clause 24 of IEC 60309-1:2021 applies.

25 Screws, current-carrying parts and connections

Clause 25 of IEC 60309-1:2021 applies.

26 Creepage distances, clearances and distances through sealing compound

Clause 26 of IEC 60309-1:2021 applies.

27 Resistance to heat, to fire and to tracking

Clause 27 of IEC 60309-1:2021 applies.

28 Corrosion and resistance to rusting

Clause 28 of IEC 60309-1:2021 applies.

29 Conditional short-circuit current withstand test

Replace the existing text with the following:

Accessories according to this document are considered to have a minimum prospective short-circuit current withstand of 10 kA. If a higher value is requested, Clause 29 of IEC 60309-1:2021 applies.

30 Electromagnetic compatibility

Clause 30 of IEC 60309-1:2021 applies.

STANDARD SHEET 2-I

16/20 A AND 32/30 A SOCKET-OUTLETS HAVING RATED OPERATING VOLTAGES EXCEEDING 50 V

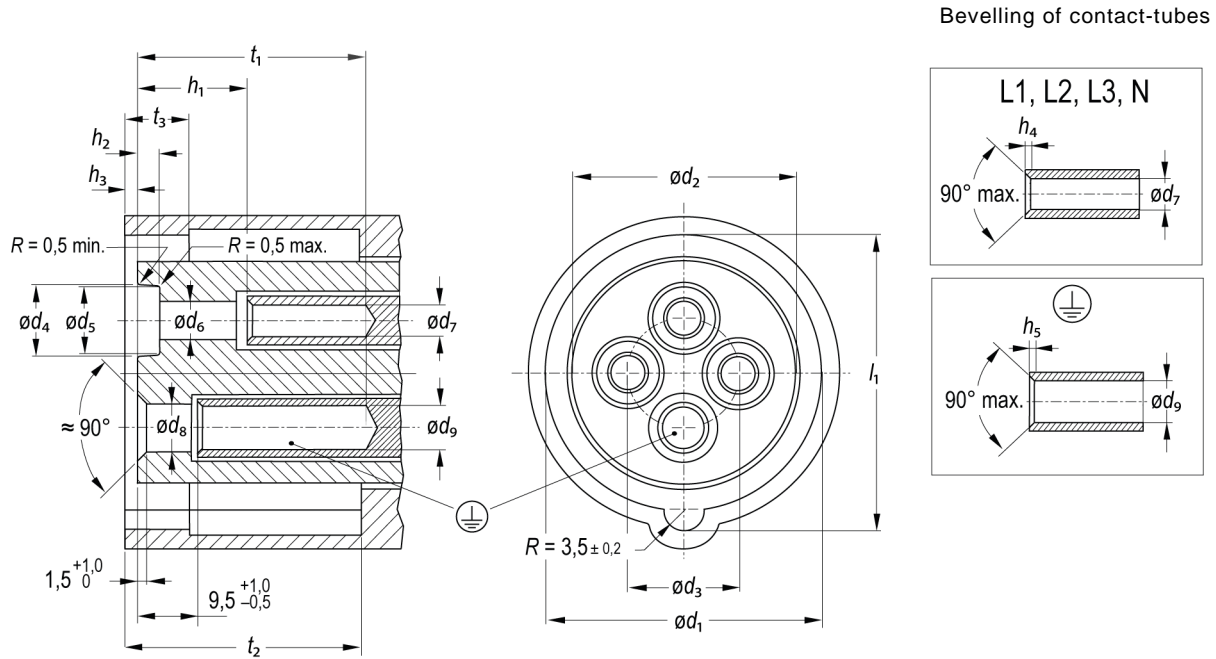

Holes or recesses in the front face, if any, other than those for contact tubes, shall not have a depth of more than 10 mm.

Exception: see footnote ^{b)} in the following table of dimensions in millimetres for standard sheet 2-I.

Socket-outlets for mechanical interlocking shall be so designed that any excessive angular movement of a fully inserted plug which would render the mechanical interlocking ineffective is prevented.

ARRANGEMENT OF CONTACT TUBES

Front view of contact tubes of socket-outlet

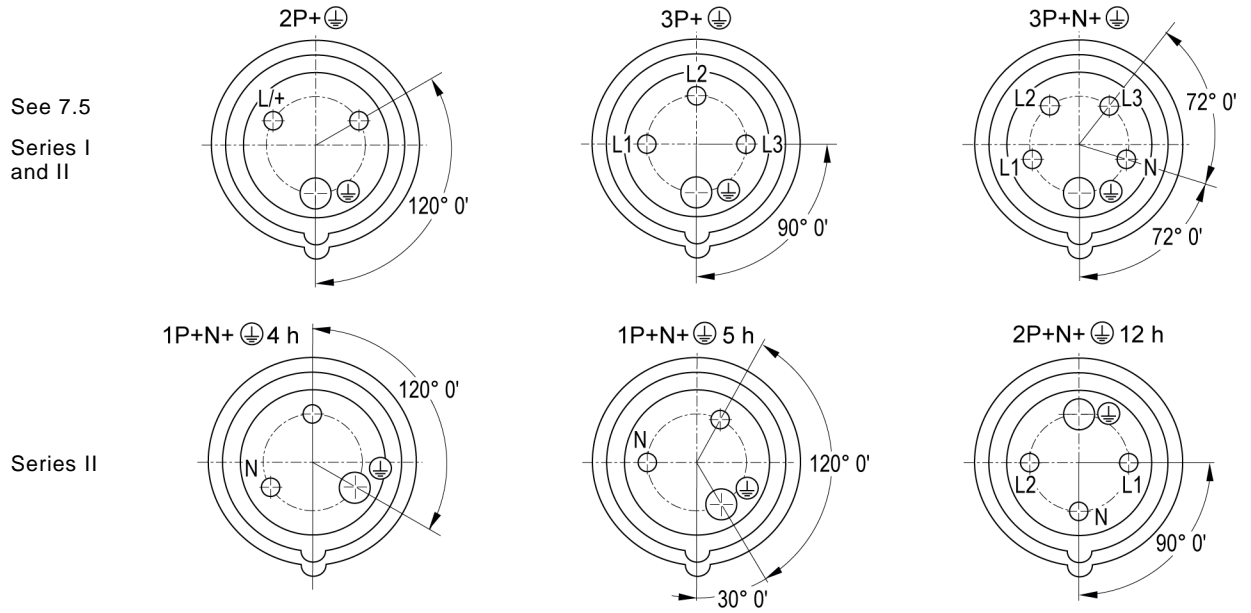

Dimensions in millimetres for standard sheet 2-1

Rated current A	Type	a) d_1	b) d_2	d_3	d_4	d_5	d_6	c) d_7	d_8	c) d_9	d) h_1	h_2	h_3	e) h_4		e) h_5		t_1	t_2	t_3	
		Tol.	0 -1,5	$\pm 0,5$	+1,0 0	Min	+0,6 0	c) d_7	+0,6 0	0 -1	Max.	Min.	Max.	Min.	Max.	Min.	Min.	Min.			
16/20	2P+E	44,3	36,0	17,5	11,6	11,0	6,0	5	8,0	7	19,5	3,8	2	0,8	0,3	1,2	0,4	47,5	37	38	10
	3P+E	50,4	40,8	21,5	11,6	11,0	6,0	5	8,0	7	19,5	3,8	2	0,8	0,3	1,2	0,4	54,0	37	38	10
	3P+N+E	57,3	46,4	26,5	11,6	11,0	6,0	5	8,0	7	19,5	3,8	2	0,8	0,3	1,2	0,4	61,3	37	38	10
32/30	2P+E	58,6	47,0	25,0	13,6	13,0	7,0	6	9,1	8	21,5	5,3	3	1,0	0,3	1,5	0,5	64,6	45	48	15
	3P+E	58,6	47,0	25,0	13,6	13,0	7,0	6	9,1	8	21,5	5,3	3	1,0	0,3	1,5	0,5	64,6	45	48	15
	3P+N+E	64,7	52,9	30,3	13,6	13,0	7,0	6	9,1	8	21,5	5,3	3	1,0	0,3	1,5	0,5	71,2	45	48	15

a) The dimensions d_1 and l_1 shall be within the prescribed limits over the distance t_3 . Beyond this distance, they may be larger but not smaller.

b) The dimension d_2 shall not exceed the prescribed limit at any point over the whole depth, and shall be within the prescribed limits over a minimum depth of 3 mm, with the exception of a maximum of:

- three cut-outs for the accessories 2P + E
- four cut-outs for the accessories 3P + E and
- five cut-outs for the accessories 3P + N + E

spaced along the circumference with not more than one between adjacent holes for the contact tubes and each having a width not exceeding 10 mm, including any radii. Holes deeper than 10 mm in the area of cut-outs are allowed.

c) The dimensions d_7 and d_9 refer to the pins; the contact tubes need not be circular.

d) For type 3P + N + E and series II, 2P + N + E, 12 h accessories, the value for the dimension h_1 is 16,0 for the neutral contact.

e) The bevelling of the contact tubes may be well rounded off towards the internal cylindrical surface within a distance of 1½ times the value h_4 max. or h_5 max.

STANDARD SHEET 2-I
(continuation 1)

RETAINING MEANS FOR SOCKET-OUTLETS

Lid or lever shown in engaged position

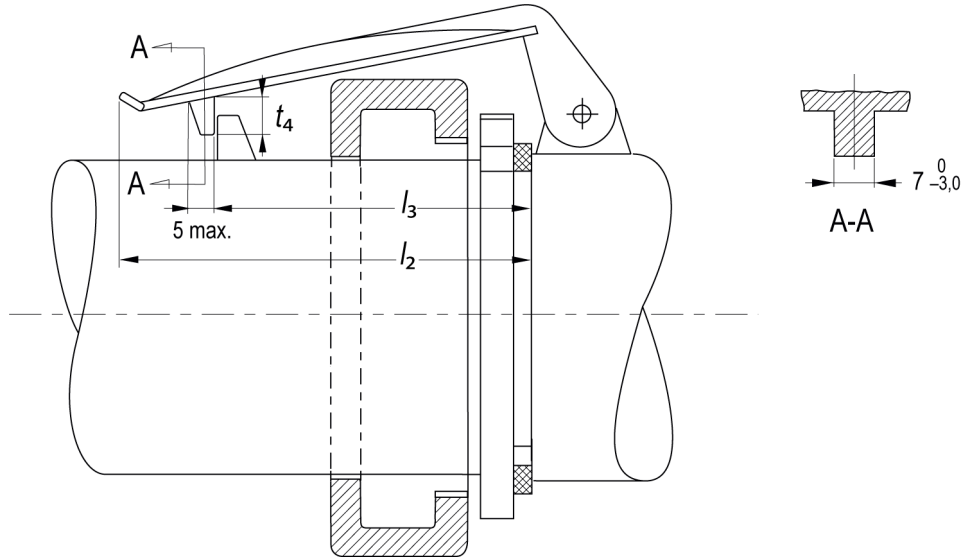

Rated current A	Type	l_2 max.	l_3	t_4 min.
16/20	2P + E	70	41,5 $\begin{smallmatrix} +1,5 \\ 0 \end{smallmatrix}$	5
	3P + E	75	47,5 $\begin{smallmatrix} +1,5 \\ 0 \end{smallmatrix}$	5
	3P + N + E	85	53,5 $\begin{smallmatrix} +1,5 \\ 0 \end{smallmatrix}$	6
32/30	2P + E	85	54,5 $\begin{smallmatrix} +1,5 \\ 0 \end{smallmatrix}$	6
	3P + E	85	54,5 $\begin{smallmatrix} +1,5 \\ 0 \end{smallmatrix}$	6
	3P + N + E	100	60,5 $\begin{smallmatrix} +2,0 \\ 0 \end{smallmatrix}$	7

Dimensions in millimetres

The dimension t_4 of the retaining device is taken from the engagement plane (see following figure).

The dimension referred to as "5 max." is taken on the engagement plane (see following figure).

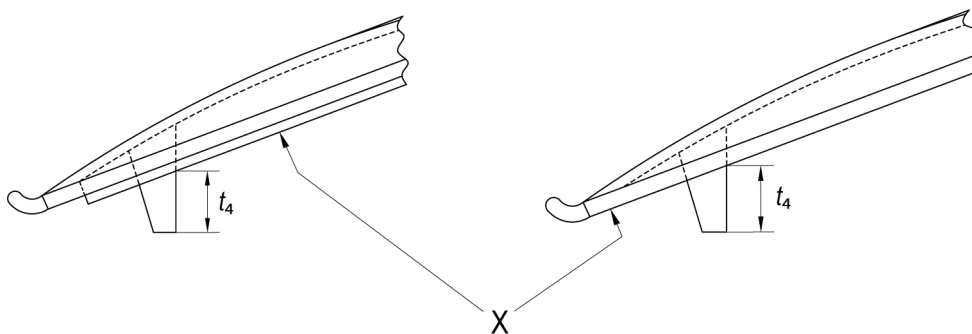

Key

X Engagement plane

For IP44 accessories, the retaining means shall be in the form of a lid such that IP66/IP67, IP67, IP67/IP69 and IP66/IP67/IP69 plugs or appliance inlets complying with standard sheet 2-II, and provided with a bayonet ring having maximum dimensions, can be correctly introduced and retained.

STANDARD SHEET 2-I
(continuation 2)

RETAINING MEANS FOR SOCKET-OUTLETS

Example of cap with chain

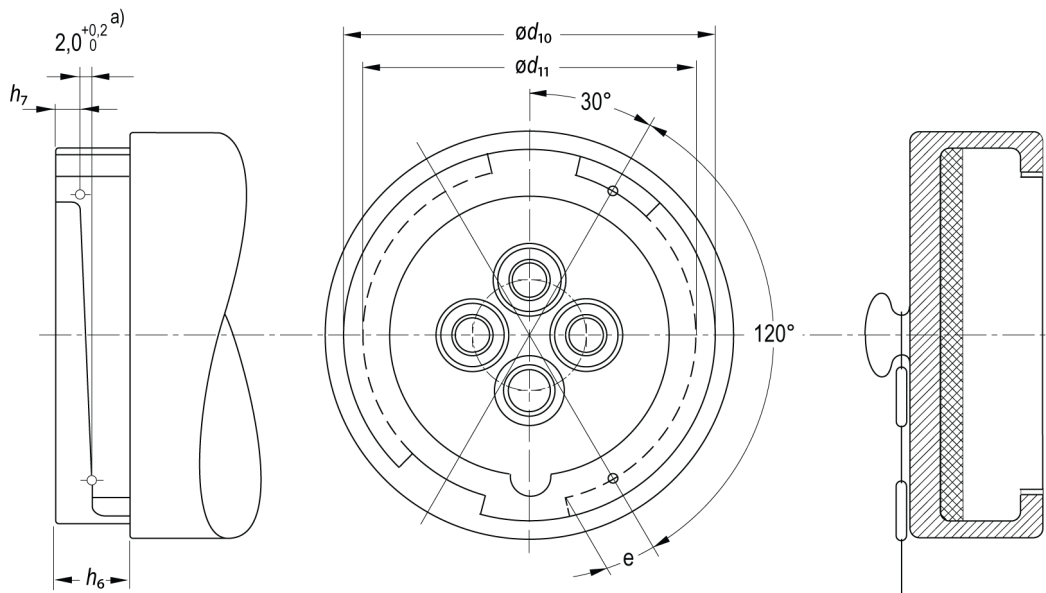

Rated current	Type	d_{10} 0 -0,5	d_{11} 0 -0,5	e min.	h_6 min.	h_7 0 -0,2
16/20	2P+E	60	53	8	12	4,2
	3P+E	68	60	10	12	4,2
	3P+N+E	76	68	12	12	4,2
32/30	2P+E	82	72	12	14	6,2
	3P+E	82	72	12	14	6,2
	3P+N+E	89	79	15	14	6,2

Dimensions in millimetres

a) The inclination of the ramps shall be such that this dimension refers to angle of 120° shown.

The retaining means shall be in the form of bayonet ramps such that IP66/IP67, IP67, IP67/IP69 and IP66/IP67/IP69 plugs or appliance inlets complying with standard sheet 2-II, and provided with a bayonet ring having maximum dimensions, can be correctly introduced at an angle of $(30 \pm 3)^\circ$ and rotated up to a maximum of 120°.

The sketches are not intended to govern design except as regards the dimensions shown.

STANDARD SHEET 2-II

16/20 A AND 32/30 A PLUGS AND APPLIANCE INLETS
HAVING RATED OPERATING VOLTAGES EXCEEDING 50 V

End of pins

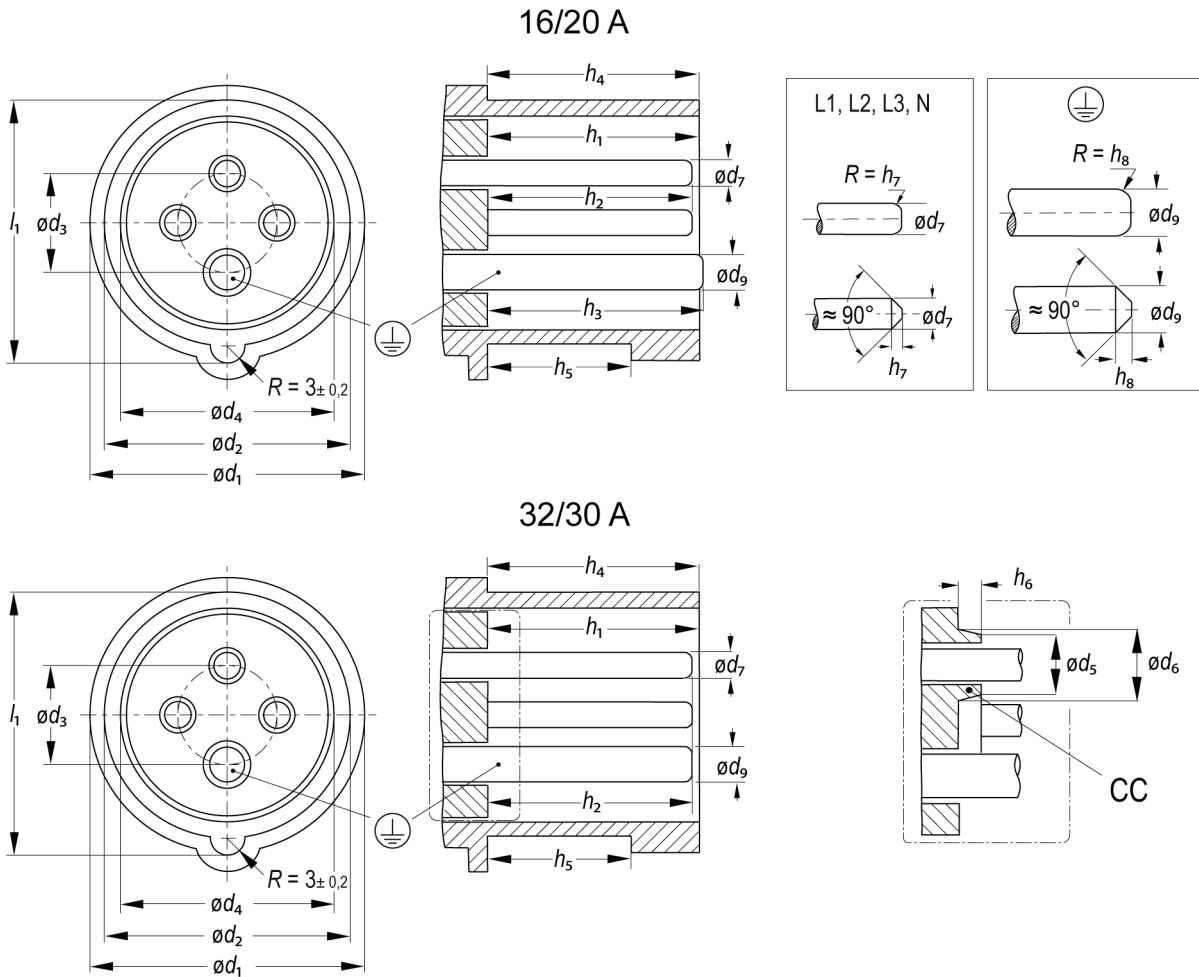

Key

CC Collar

ARRANGEMENT OF PINS

Front view of pins of plugs or appliance inlet

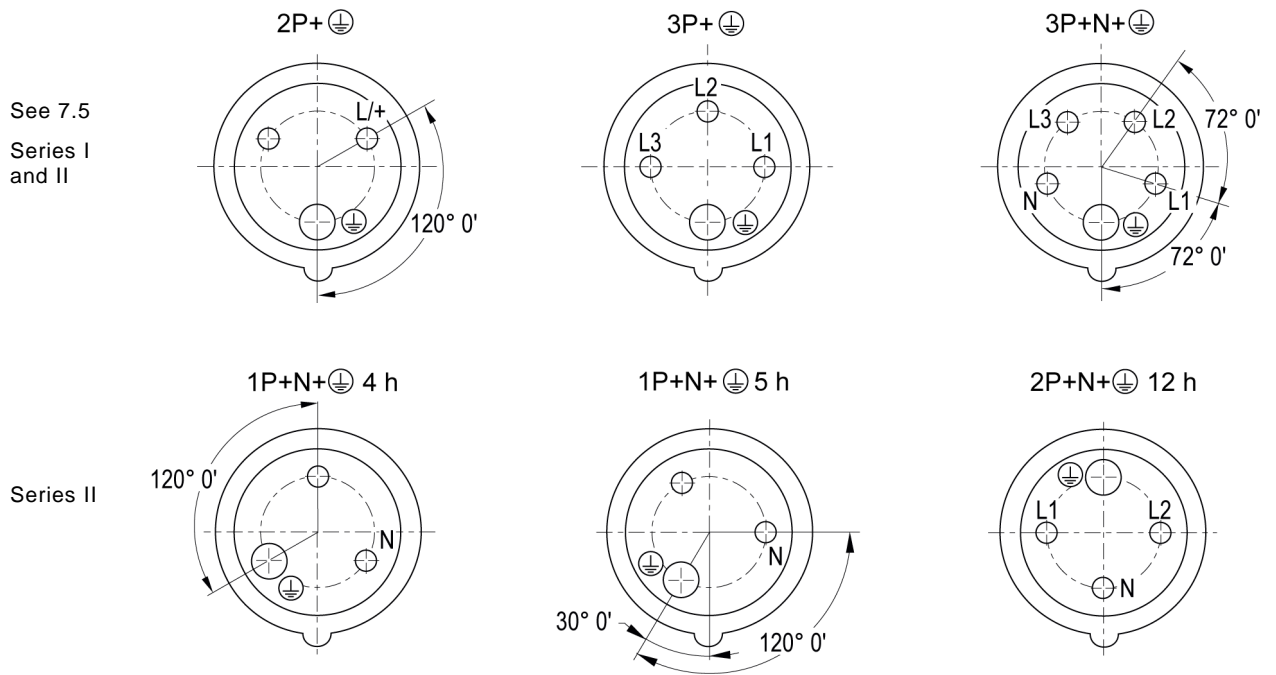

Dimensions for standard sheet 2-II

Rated current	Type	d_1	d_2	d_3	d_4		d_5	d_6	d_7	d_9	h_1	h_2	h_3	h_4	h_5	h_6	h_7		h_8		l_1		
		min		$\pm 0,5$	d)	e)	max.	max.	0 -0,075	0 -0,09	0 -1	0 -1	0 -1	0 -1	0 -1	0 -1	max.	min.	max.	min.	d)	e)	
A	2P + E	47,5	43,5 -0,6	17,5	37,9 0	+1,9 0	+1,5 0	11	10	5	7	36	38	37	24,0	27,5	3,5	1,7	0,8	1,5	0,75	46,5	47,0 -0,4
	3P + E	53,5	49,5 -0,6	21,5	42,8 0	+1,9 0	+1,5 0	11	10	5	7	36	38	37	24,0	27,5	3,5	1,7	0,8	1,5	0,75	52,9	53,6 -0,5
	3P + N + E	60,5	56,1 -0,6	26,5	48,8 0	+1,9 0	+1,5 0	11	10	5	7	36	38	37	24,0	27,5	3,5	1,7	0,8	1,5	0,75	60,1	61,0 -0,6
32/30	2P + E	61,5	57,3 -0,8	25,0	49,7 0	+1,9 0	+1,6 0	13	12	6	8	45	-	46	32,0	35,5	5,0	2,0	1,0	2,5	1,2	63,2	63,2 -0,6
	3P + E	61,5	57,3 -0,8	25,0	49,7 0	+1,9 0	+1,6 0	13	12	6	8	45	-	46	32,0	35,5	5,0	2,0	1,0	2,5	1,2	63,2	63,2 -0,6
	3P + N + E	67,5	63,4 -0,8	30,3	55,6 0	+1,9 0	+1,6 0	13	12	6	8	45	-	46	32,0	35,5	5,0	2,0	1,0	2,5	1,2	69,9	69,9 -0,7

Dimensions in millimetres

- a) Collars, as shown in the detail, required for accessories having rated operating voltages exceeding 500 V, optional for other accessories.
- b) For IP44 accessories.
- c) For IP66/IP67, IP67, IP67/IP69 and IP66/IP67/IP69 accessories.
- d) For accessories with metal enclosures.
- e) For accessories with enclosures of insulating material.
- f) The end of the pins may be well rounded off towards the external cylindrical surface within a distance of $1\frac{1}{2}$ times the value h_7 max. or h_8 max.
- g) Dimension d_7 shall be within the tolerances for the whole h_2 .
- h) Dimension d_9 shall be within the tolerances for the whole h_3 .

STANDARD SHEET 2-II
(continuation 1)

RETAINING MEANS FOR PLUGS AND APPLIANCE INLETS

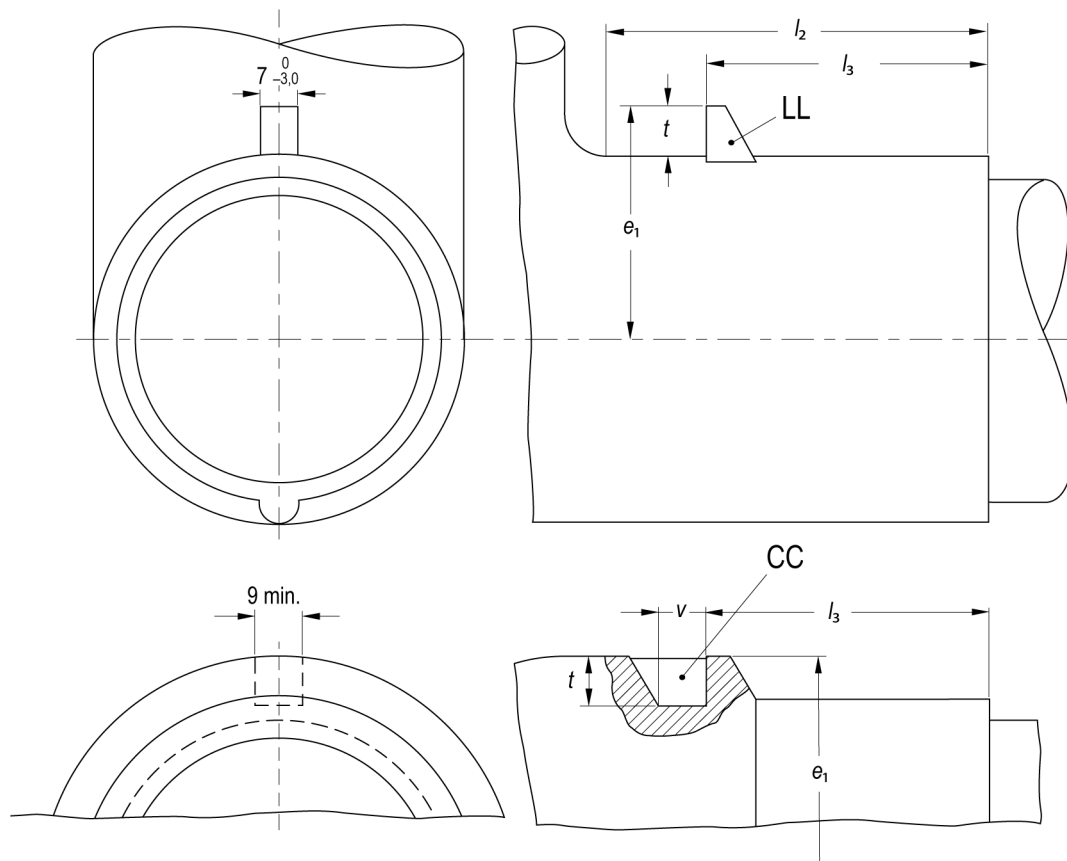

Key

CC Cavity

LL Lug

Rated current		e_1	a) l_2	l_3	t	v
A		$\begin{matrix} 0 \\ -2 \end{matrix}$	min.		min.	min.
16/20	2P + E	31	75	41 $\begin{matrix} 0 \\ -1,0 \end{matrix}$	4	8
	3P + E	35	80	47 $\begin{matrix} 0 \\ -1,0 \end{matrix}$	5	8
	3P + N + E	39	90	53 $\begin{matrix} 0 \\ -1,0 \end{matrix}$	7	8
32/30	2P + E	41	90	54 $\begin{matrix} 0 \\ -1,0 \end{matrix}$	7	8
	3P + E	41	90	54 $\begin{matrix} 0 \\ -1,0 \end{matrix}$	7	8
	3P + N + E	46	105	60 $\begin{matrix} 0 \\ -1,5 \end{matrix}$	8	9

Dimensions in millimetres

a) Minimum clearance required for movement of hinged lid.

The retaining means shall be in the form of a lug or a cavity, at position 12 h.

STANDARD SHEET 2-II
(continuation 2)

RETAINING MEANS FOR PLUGS AND APPLIANCE INLETS

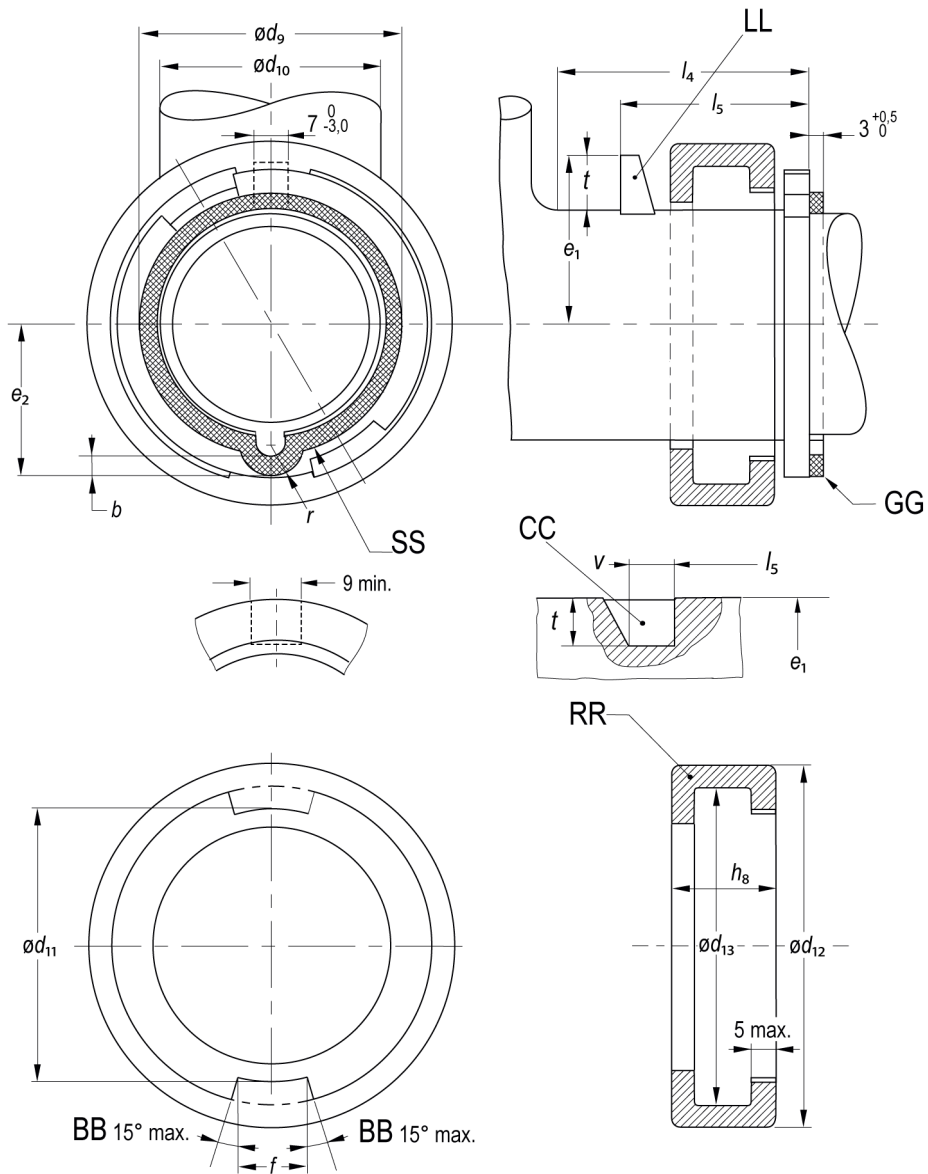

Key

- BB Bevel
- CC Cavity
- GG Gasket
- LL Lug
- RR Bayonet ring
- SS Sealing surface

Dimensions in millimetres for standard sheet 2-II

(continuation 2)

Rated current A	Type	Nose and cavity						Sealing surface					Bayonet ring				
		e_1	a) l_4	l_5	t	v	b	d_9	d_{10}	e_2	r	d_{11}	d_{12}	d_{13}	f	h_8	
		$\begin{matrix} 0 \\ -2 \end{matrix}$	min.		min.	min.	min.	min.	max.	min.	min.	$\begin{matrix} +0,5 \\ 0 \end{matrix}$	max.	min.	$\begin{matrix} 0 \\ -0,5 \end{matrix}$	max.	
16/20	2P + E	31	75	$\begin{matrix} 38 \\ -1,0 \end{matrix}$	4	8	3,0	50,8	44,8	28,6	6,7	53,5	73	60,5	12	22	
	3P + E	35	80	$\begin{matrix} 44 \\ -1,0 \end{matrix}$	5	8	3,5	57,9	50,9	32,6	7,2	60,5	81	68,5	16	24	
	3P + N + E	39	90	$\begin{matrix} 50 \\ -1,0 \end{matrix}$	7	8	4,0	65,8	57,8	36,9	7,7	68,5	89	76,5	19	26	
32/30	2P + E	41	90	$\begin{matrix} 51 \\ -1,0 \end{matrix}$	7	8	4,6	69,5	59,1	40,1	8,2	72,5	95	82,5	19	30	
	3P + E	41	90	$\begin{matrix} 51 \\ -1,0 \end{matrix}$	7	8	4,6	69,5	59,1	40,1	8,2	72,5	95	82,5	19	30	
	3P + N + E	46	105	$\begin{matrix} 57 \\ -1,5 \end{matrix}$	8	9	5,3	76,6	65,2	43,4	9,0	79,5	102	89,5	22	32	

a) Minimum clearance required for movement of hinged lid.

The retaining means shall be in the form of a bayonet ring and a lug or a cavity, at position 12 h.

The sketches are not intended to govern design except as regards the dimensions shown.

STANDARD SHEET 2-III

63/60 A AND 125/100 A SOCKET-OUTLETS HAVING RATED OPERATING VOLTAGES EXCEEDING 50 V

WITHOUT PILOT CONTACT

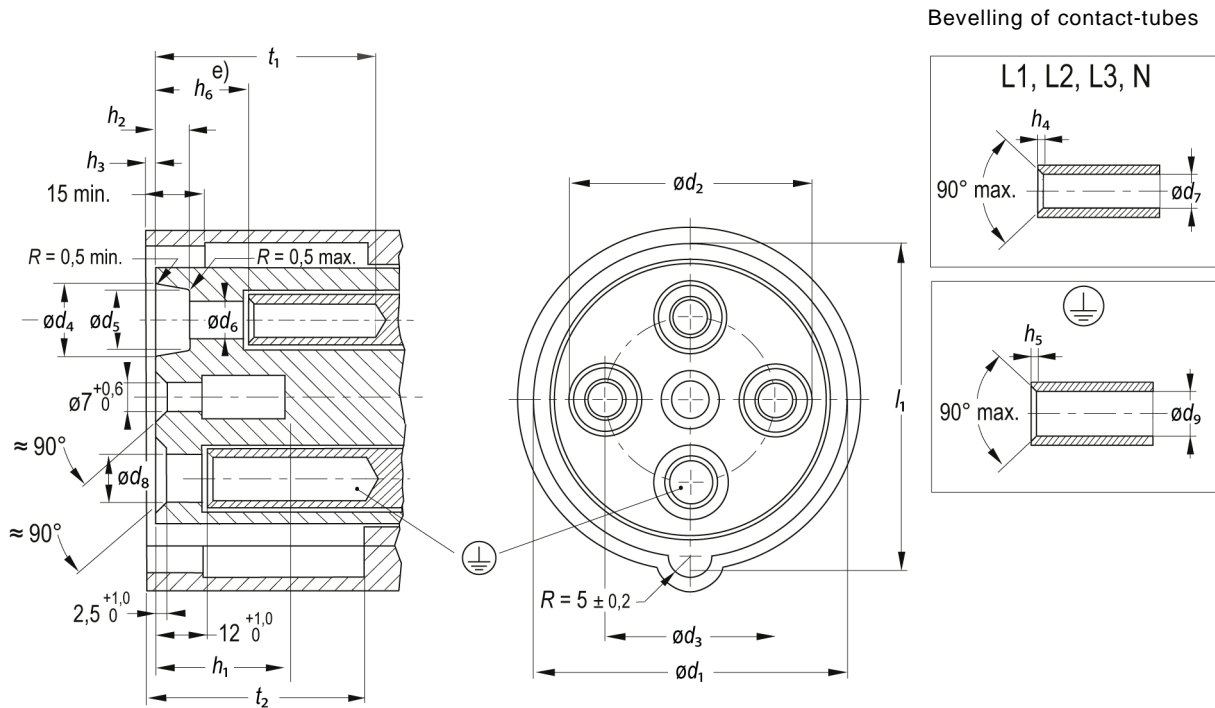

A hole in the front face is mandatory to accept the pilot pins of plugs or appliance inlets.

Holes or recesses in the front face, if any, other than those for contact holes shall have a depth of not more than 10 mm except for pilot pin holes. Exception: see footnote b) in the table below titled Dimensions for STANDARD SHEETS 2-III and 2-IIIa.

Socket-outlets for mechanical interlocking shall be so designed that any angular movement of a fully inserted plug which would render the mechanical interlocking ineffective is prevented.

ARRANGEMENT OF CONTACT TUBES

Front view of contact tubes of socket-outlet

See 7.5
Series I and
series II

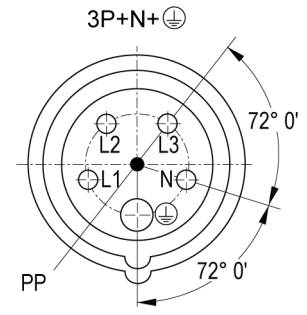
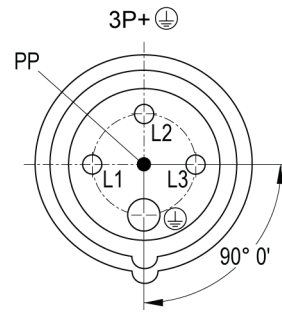
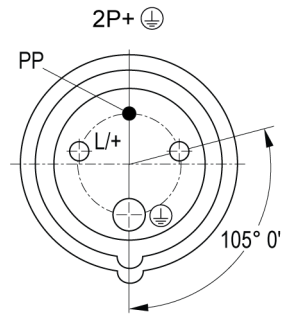

Series II

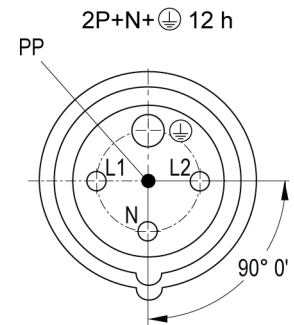
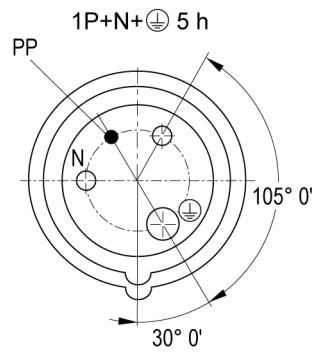
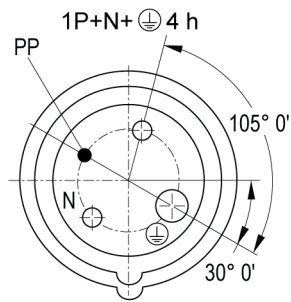

Key

PP Hole to accept pilot pin

STANDARD SHEET 2-IIIa

63/60 A AND 125/100 A SOCKET-OUTLETS HAVING RATED OPERATING VOLTAGES EXCEEDING 50 V

WITH PILOT CONTACT

Bevelling of contact tubes

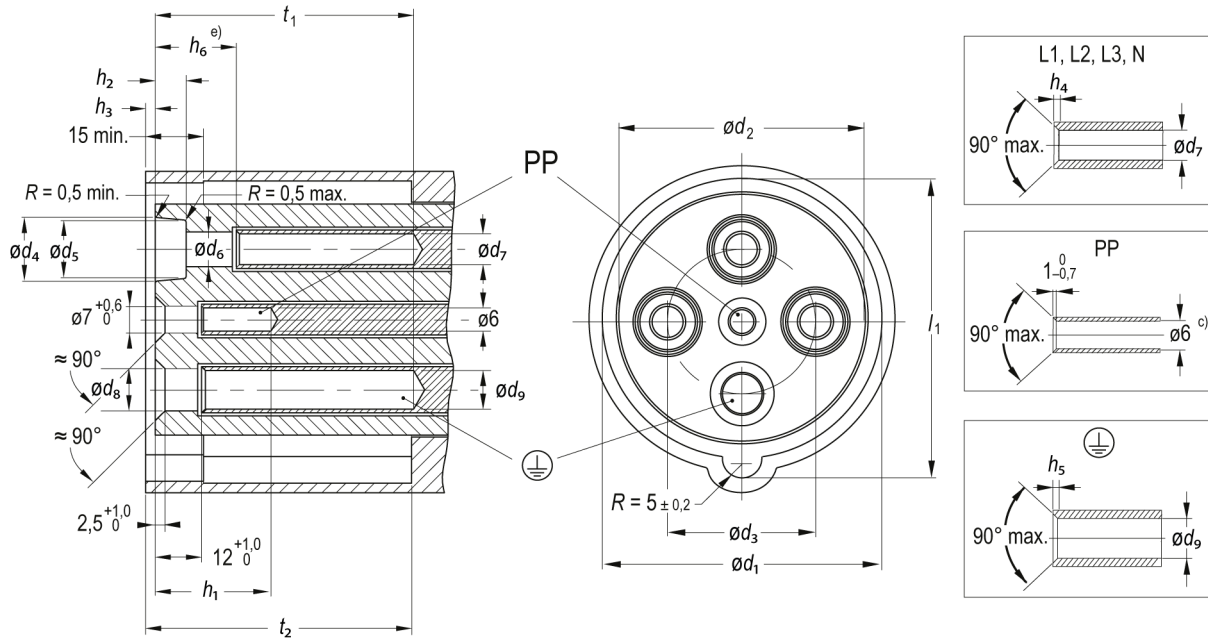

Key

PP Pilot

Holes or recesses in the front face, if any, other than those for contact tubes, shall have a depth of not more than 10 mm. Exception: see footnote b) in the table below titled Dimensions for STANDARD SHEETS 2-III and 2-IIIa.

Socket-outlets for mechanical interlocking shall be so designed that any excessive movement of a fully inserted plug which would render the mechanical interlocking ineffective is prevented.

ARRANGEMENT OF CONTACT TUBES

Front view of contact tubes of socket-outlet

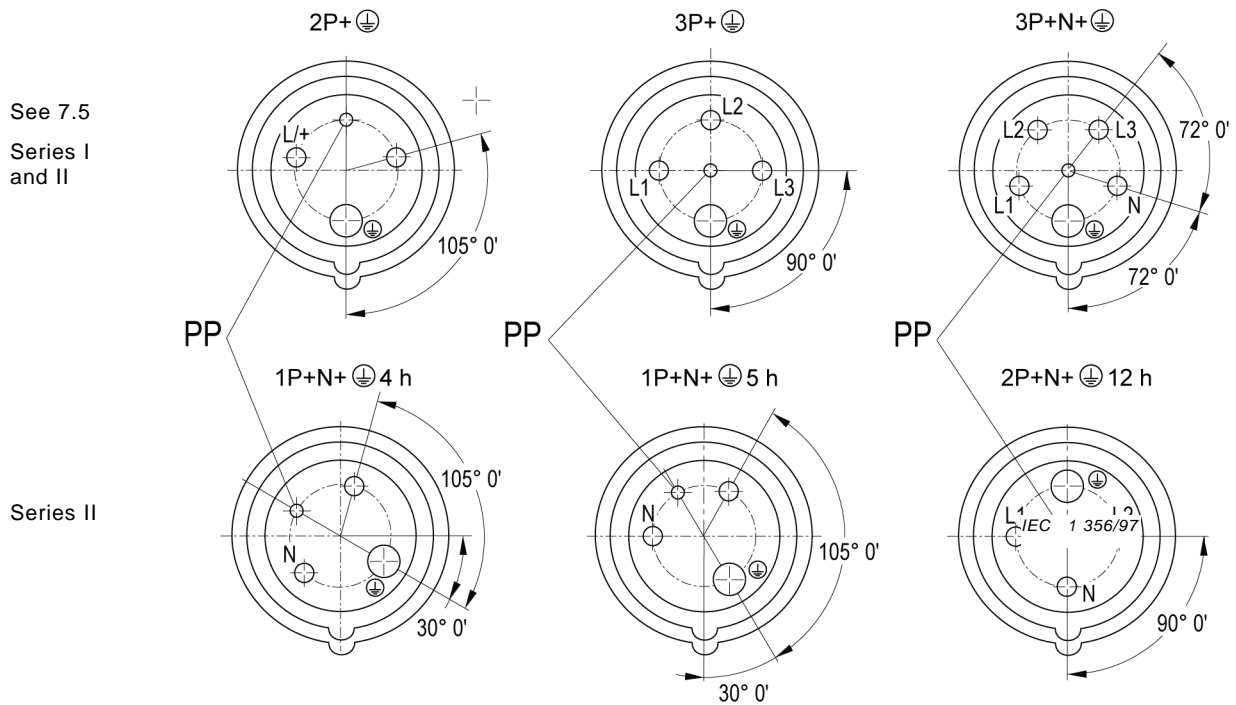

See 7.5
Series I
and II

Series II

Key

PP Pilot

Dimensions for STANDARD SHEETS 2-III and 2-IIIa

All types	Rated current A	a)		b)				c)			d)			d)		a)		
		d_1	d_2	d_3	d_4	d_5	d_6	d_7	d_8	d_9	h_1	h_2	h_3	h_4	h_5	l_1	t_1	t_2
2P + E	63/60	+0,8 0	0 -1,5	±0,5	+1,0 0	min.	+0,6 0		+0,6 0	min.	+3,0 0	0 -1	max. min.	max. min.	2,0 0,6	77,5 0	67 min.	69 min.
3P + E	125/100	83,0	71,0	42,5	21,0	19,0	11,0	10	14,0	12	32,0	10,0	4	2,0 0,6	2,5 0,8	89,5	71	76
3P + N + E																		

Dimensions in millimetres

- a) The dimensions d_1 and l_1 shall be within the prescribed limits over a distance of 15 mm. Beyond this distance, they may be larger but not smaller.
- b) The dimension d_2 shall not exceed the prescribed limit at any point over the whole depth, and shall be within the prescribed limits over a minimum depth of 6 mm with the exception of a maximum of:
 - three cut-outs for accessories 2P + E,
 - four cut-outs for accessories 3P + E, and
 - five cut-outs for accessories 3P + N + E,
 spaced along the circumference, with not more than one between adjacent holes for the contact tubes, and each having a width not exceeding 15 mm including any radii. Holes deeper than 10 mm in the area of cut-outs are allowed.
- c) The dimensions d_7 and d_9 refer to the pins; the contact tubes need not be circular.
- d) The bevelling of the contact tubes may be rounded off towards the internal cylindrical surface within a distance of 1½ times the values h_4 max. or h_5 max.
- e) h_6 shall be in accordance with the table below.

Value of h_6 for standard sheets 2-III and 2-IIIa

Type	$h_6 \begin{smallmatrix} +1 \\ 0 \end{smallmatrix}$ mm ^{a)}	
	63/60 A	125/100 A
Electrically interlocked assemblies	21	21
Mechanically interlocked assemblies	21 or 40	21 or 40
	21 or 40	40
Without interlock		
<i>Dimensions in millimetres</i>		
^{a)} For 3P + N + E and series II, 2P + N + E 12 h, accessories, the depth of the neutral contact shall be less than that for the phase contacts but greater than that for the earth contact.		

STANDARD SHEET 2-III
(continuation 1)

RETAINING MEANS FOR 63/60 A SOCKET-OUTLETS

ALL TYPES

Lid shown in engaged position

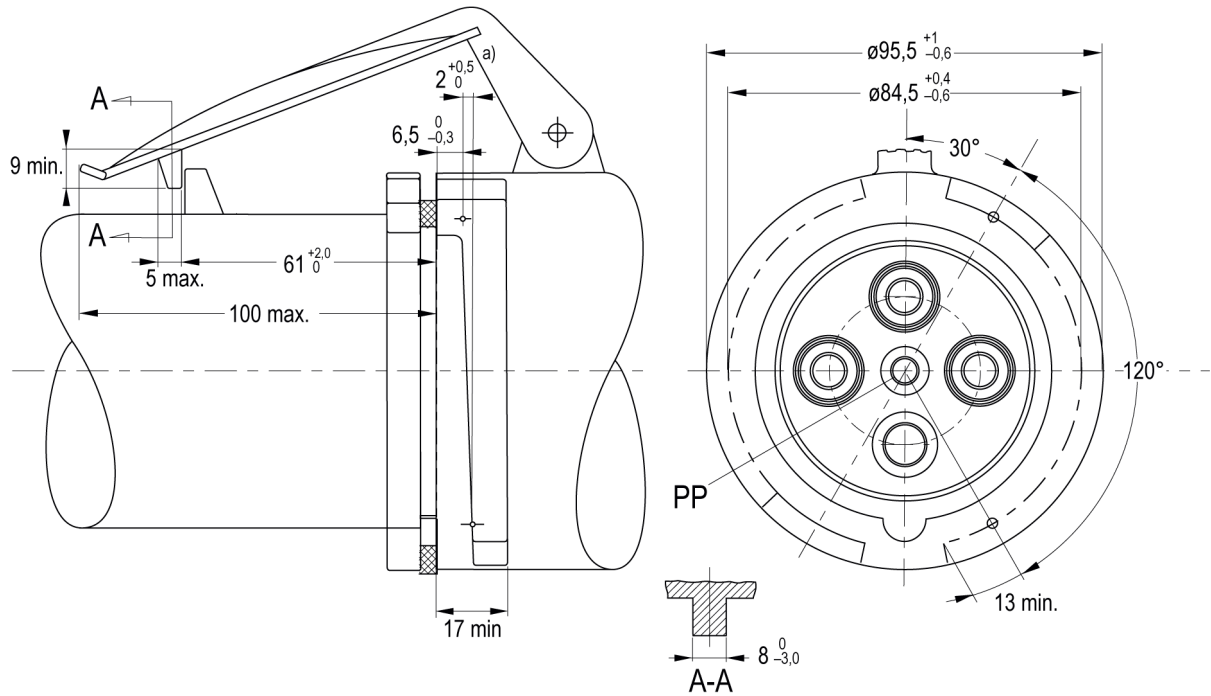

Dimensions in millimetres

The inclination of the ramps shall be such that this dimension refers to the angle of 120° shown.

Key

PP Pilot

The dimension t_4 of the retaining device is taken from the engagement plane (see following figure).

The dimension referred to as "5 max." is taken on the engagement plane (see following figure).

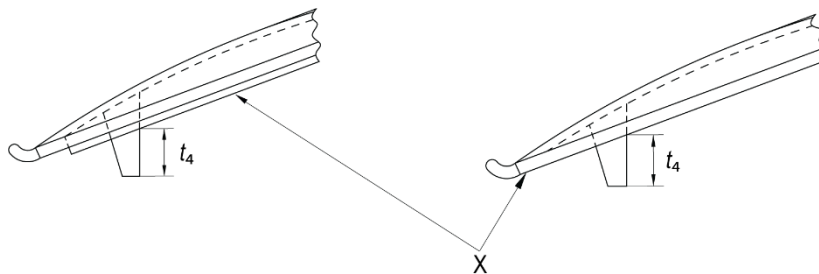

Key

X Engagement plane

The retaining means shall be in the form of bayonet ramps and a lid such that IP66/IP67, IP67, IP67/IP69 and IP66/IP67/IP69 plugs or appliance inlets complying with standard sheets 2-IV and 2-IVa, and provided with a bayonet ring having maximum dimensions, can be correctly introduced at an angle of $(30 \pm 3)^\circ$ and rotated up to a maximum of 120°.

STANDARD SHEET 2-III
(continuation 2)

RETAINING MEANS FOR 63/60 A AND 125/100 A SOCKET-OUTLETS

ALL TYPES

Example of cap with chain

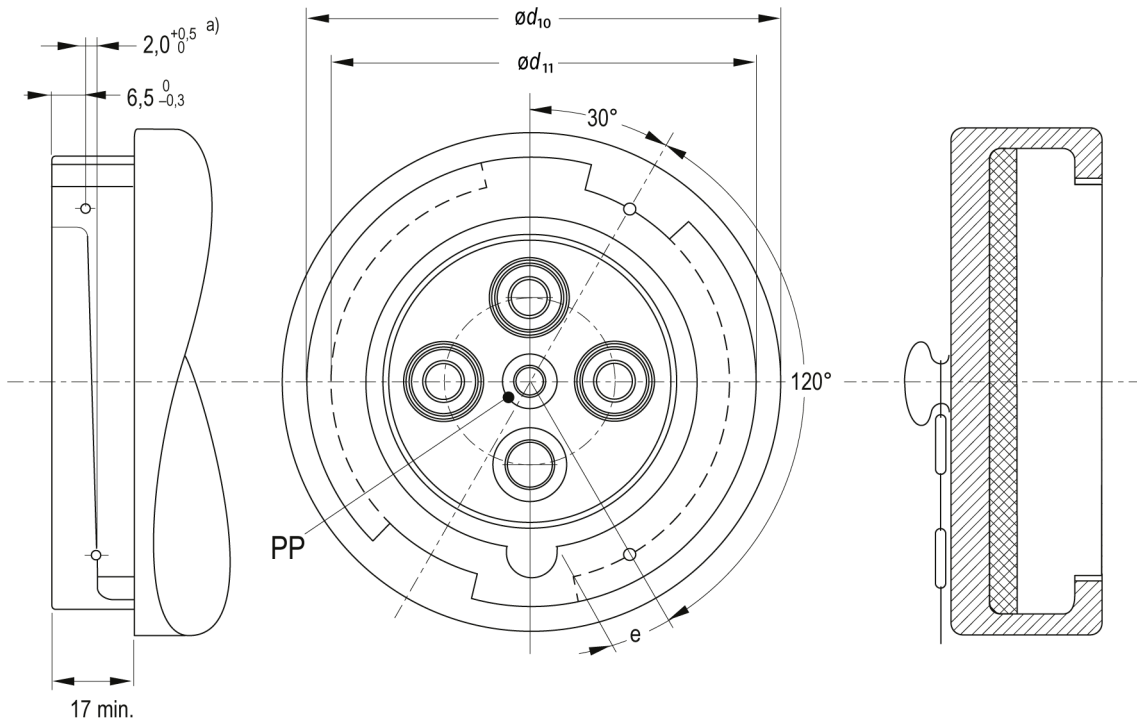

Key

PP Pilot

Type	Rated current A	d_{10} +1 -0,6	d_{11} +0,4 -0,6	e min.
2P + E	63/60	95,5	84,5	13
3P + E	125/100	108,5	97,5	16
3P + N + E				

Dimensions in millimetres

a) The inclination of the ramps shall be such that this dimension refers to the angle of 120° shown.

The retaining means shall be in the form of bayonet ramps such that IP66/IP67, IP67, IP67/IP69 and IP66/IP67/IP69 plugs or appliance inlets complying with standard sheets 2-IV and 2-IVa, and provided with a bayonet ring having maximum dimensions, can be correctly introduced at an angle of $(30 \pm 3)^\circ$ and rotated up to a maximum of 120°.

The sketches are not intended to govern design except as regards the dimensions shown.

STANDARD SHEET 2-IV

63/60 A AND 125/100 A PLUGS AND APPLIANCE INLETS
HAVING RATED OPERATING VOLTAGES EXCEEDING 50 V

WITHOUT PILOT PIN

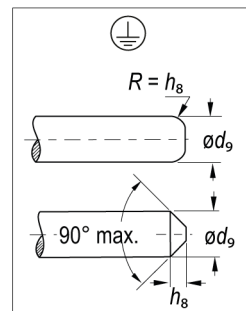
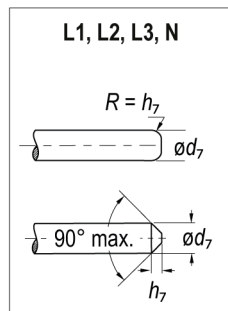
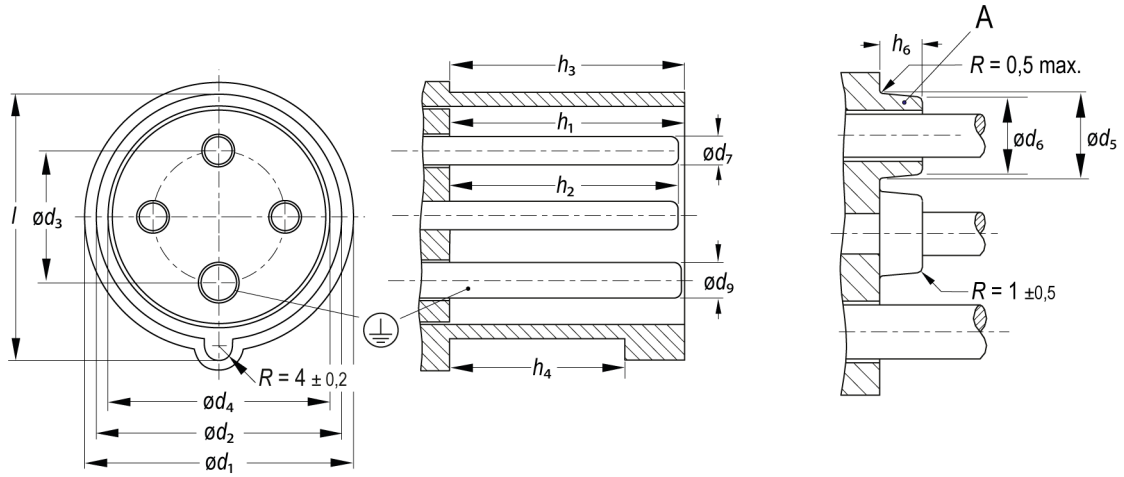

ARRANGEMENT OF PINS

Front view of pins of plug or appliance inlet

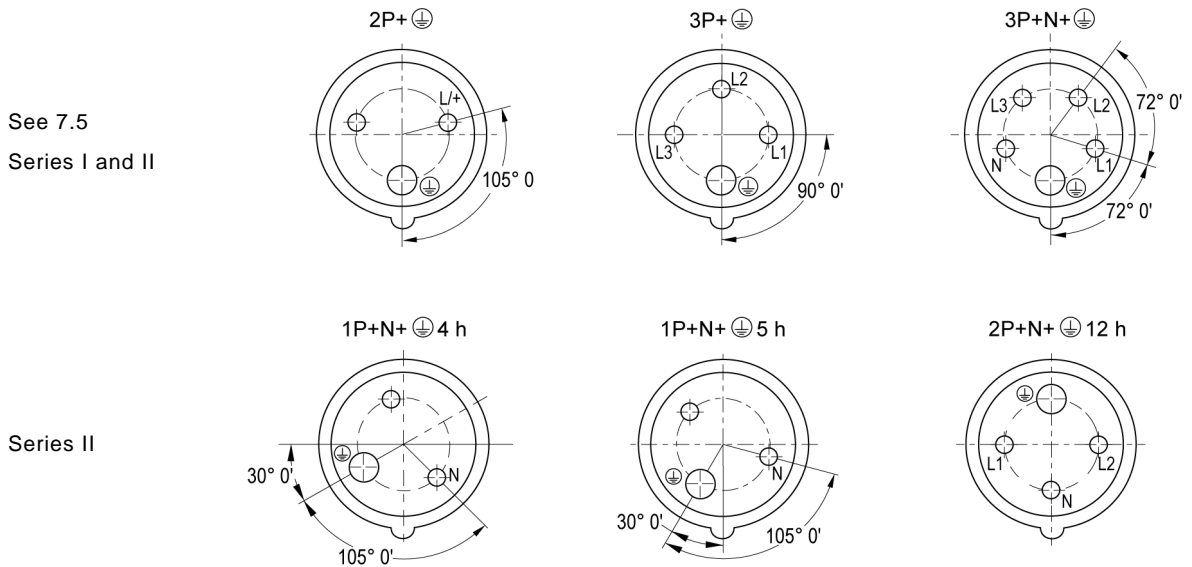

STANDARD SHEET 2-IVa

63/60 A AND 125/100 A PLUG AND APPLIANCE INLETS
HAVING RATED OPERATING VOLTAGES EXCEEDING 50 V

WITH PILOT PIN

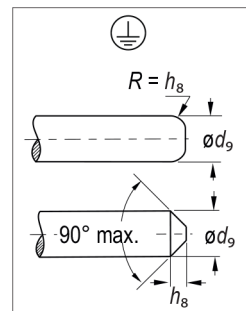
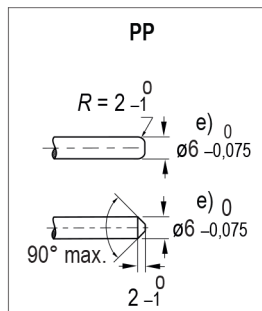
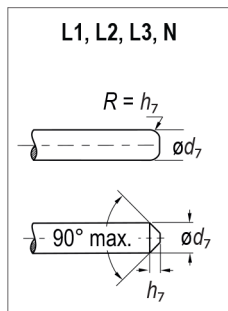
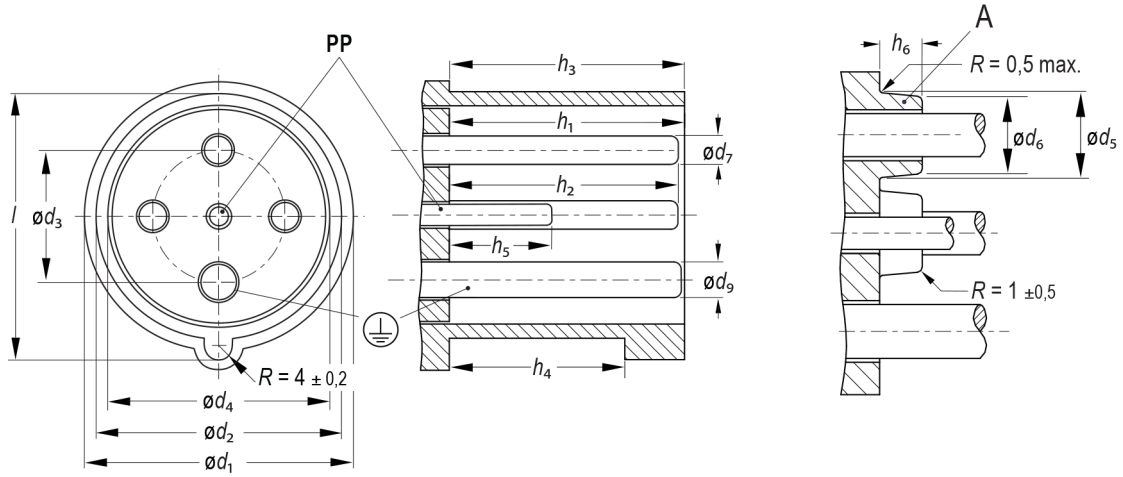

IEC

Key

- A Collar
- PP Pilot

ARRANGEMENT OF PINS

Front view of pins of plug or appliance inlet

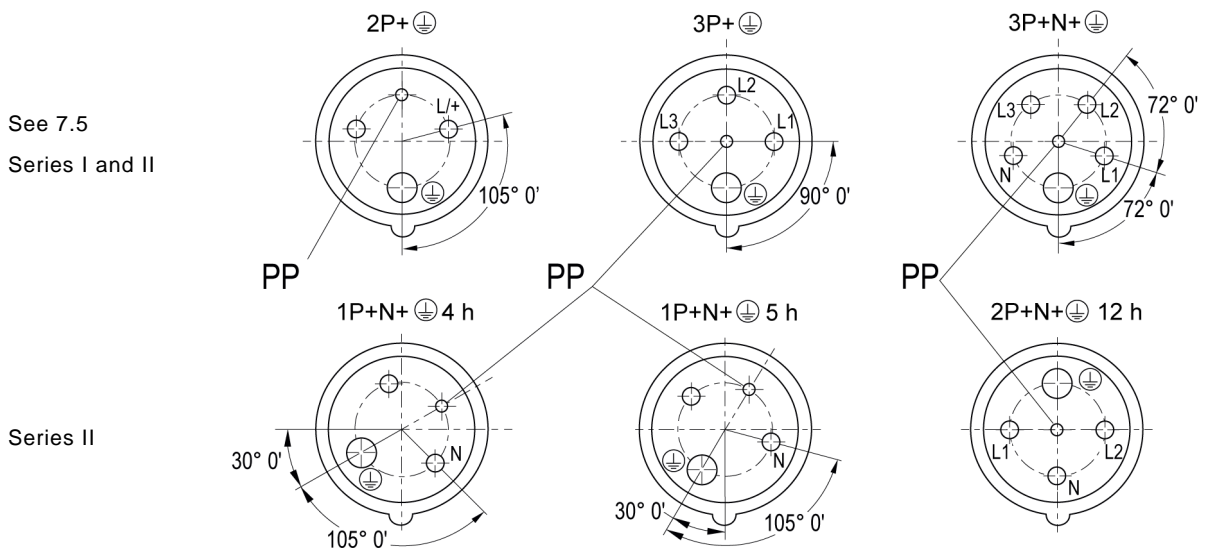

See 7.5
Series I and II

Series II

Dimensions for standard sheets 2-IV and 2-IVa

Type	Rated current A	d_1	d_2	d_3	d_4	a)	a)	c)	d)	h_1	h_2	h_3	h_4	h_5	a)	b)		b)		l
		min.	0 -0,8	$\pm 0,5$		max.	max.	0 -0,09	0 -0,11	0 -1,0	0 -1,0	0 -1,0	+2 0	0 -1,0	max.	h_7		h_8		0 -0,6
															max.	min.	max.	min.		
2P + E	63/60	75,5	69,5	36,5	61,5 +2 0	15,8	14,3	8	10	67,0	66,0	67,0	50	29,0	8	2,5	1,2	3,0	1,5	75,5
3P + E	125/100	87,5	81,5	42,5	72,5 +2,5 0	20,2	18,2	10	12	74,5	69,5	75,5	58	31,5	10	3,0	1,5	4,0	2,0	87,5
3P + N + E																				

Dimensions in millimetres

- a) Collars, as shown in the detail, required for accessories having rated operating voltages exceeding 500 V, optional for other accessories.
- b) The end of the pins may be rounded off towards the external cylindrical surface within a distance of 1½ times the value h_7 max. or h_8 max.
- c) Dimension d_7 shall be within the tolerances for the whole h_2 .
- d) Dimension d_9 shall be within the tolerances for the whole h_3 .
- e) This dimension shall be within the tolerances for the whole h_5 .

STANDARD SHEET 2-IV
(continuation 1)

RETAINING MEANS FOR 63/60 A PLUGS AND APPLIANCE INLETS

ALL TYPES

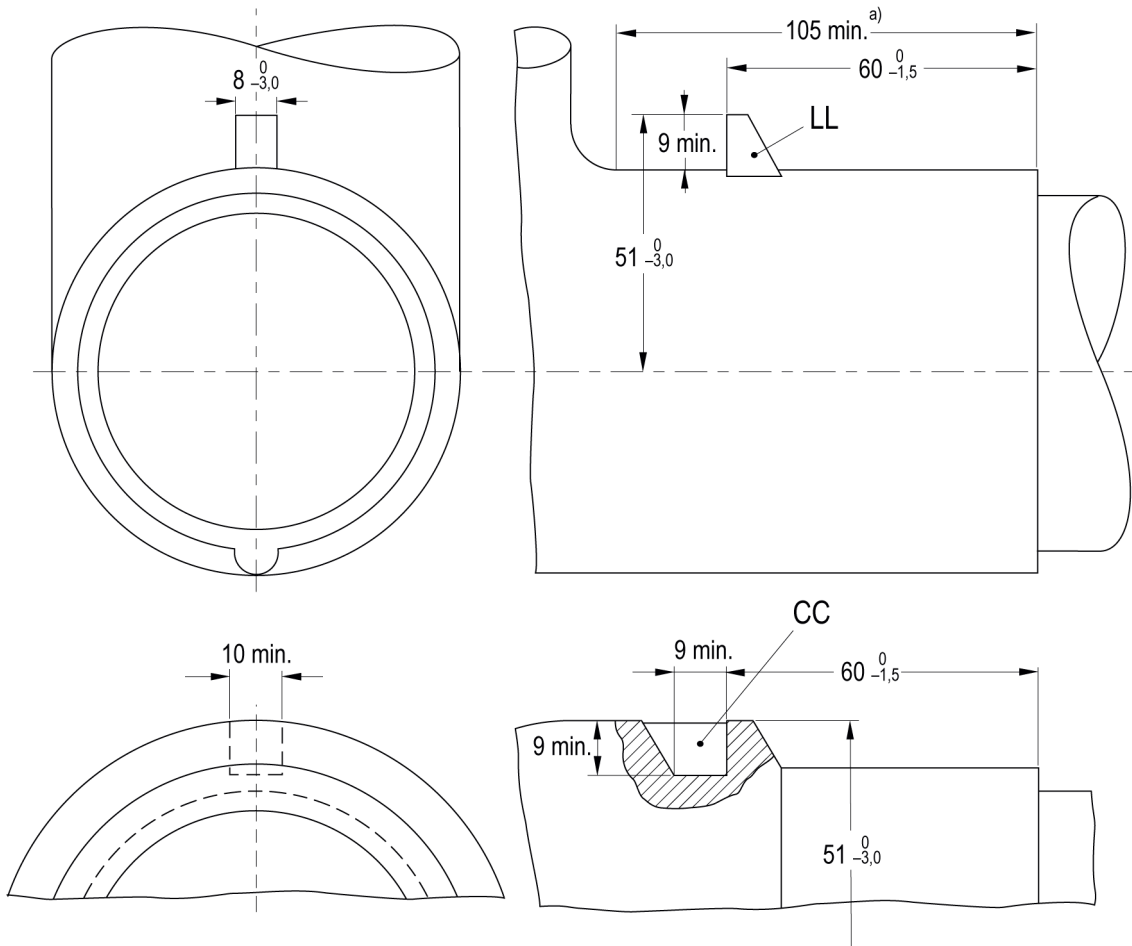

Key

CC Cavity

LL Lug

Dimensions in millimetres

^{a)} Minimum clearance required for movement of hinged lid.

The retaining means shall be in the form of a lug or a cavity, at position 12 h.

STANDARD SHEET 2-IV
(continuation 2)

RETAINING MEANS FOR 63/60 A AND 125/100 A PLUGS AND APPLIANCE INLETS

ALL TYPES

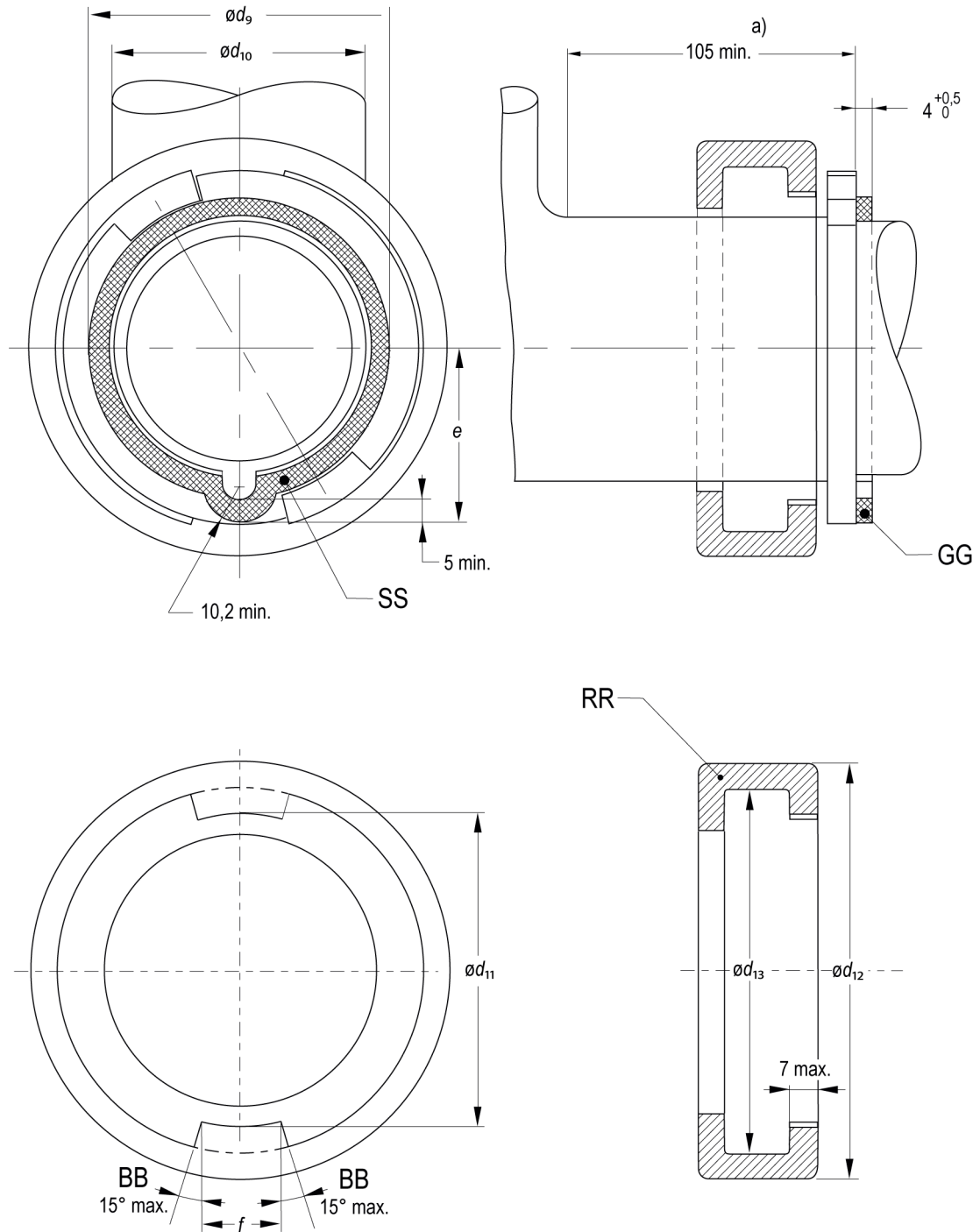

Key

- BB Bevel
- GG Gasket
- RR Bayonet ring
- SS Sealing surface

Dimensions for standard sheet 2-IV (continuation 2)

Type	Rated current A	Sealing surface			Bayonet ring				
		d_9 min.	d_{10} max.	e min.	d_{11} +0,6 -0,4	d_{12} max.	d_{13} min.	f 0 -0,5	h_9 max.
2P + E	63/60	81,5	71,5	46,8	86,0	114	98	22	32
3P + E 3P + N + E	125/100	93,5	83,5	53,3	99,0	131	111	27	35

Dimensions in millimetres

a) Minimum clearance required for movement of hinged lid; applicable only to 63/60 A accessories.

The retaining means shall be in the form of a bayonet ring.

The sketches are not intended to govern design except as regards the dimensions shown.

STANDARDS SHEET 2-V

MECHANICAL INTERLOCK FOR 16/20 A, 32/30 A, 63/60 A AND 125/100 A ACCESSORIES HAVING RATED OPERATING VOLTAGES EXCEEDING 50 V

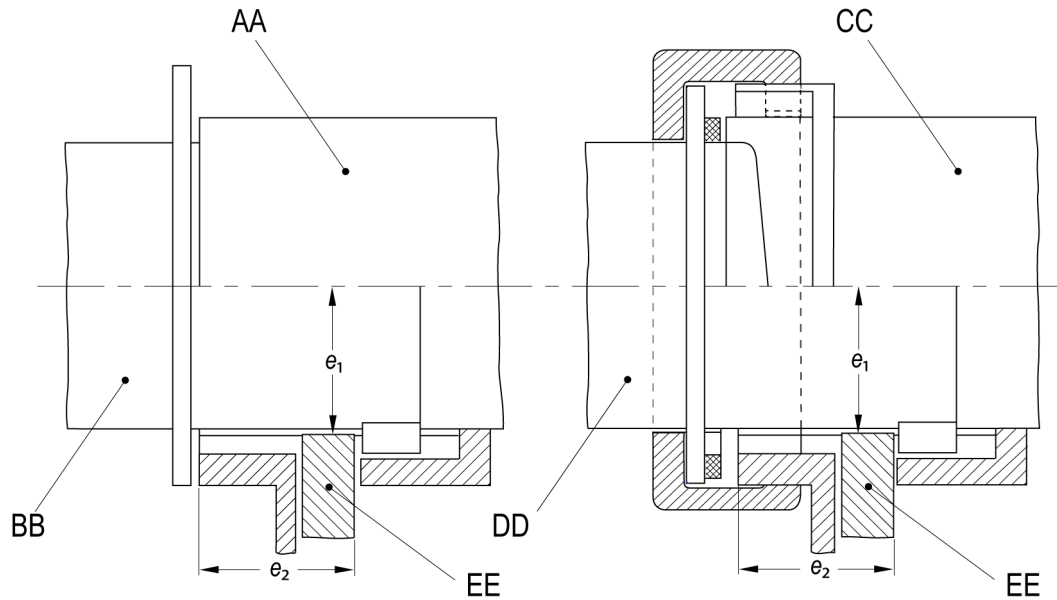

Key

- AA IP44 socket-outlet
- BB IP44 plug or appliance inlet
- CC IP66/IP67, IP67, IP67/IP69 and IP66/IP67/IP69 socket-outlet
- DD IP66/IP67, IP67, IP67/IP69 and IP66/IP67/IP69 plug or appliance inlet
- EE Interlocking member

Dimensions for standard sheet 2-V

Rated current A	Type	e_1		e_2	
			Tol.		Tol.
16/20	2P + E	22,0	+0,5 0	23,5	0 -0,3
	3P + E	25,0	+0,5 0	23,5	0 -0,3
	3P + N + E	28,3	+0,5 0	23,5	0 -0,3
32/30	2P + E	29,0	+0,7 0	31,5	0 -0,5
	3P + E	29,0	+0,7 0	31,5	0 -0,5
	3P + N + E	32,1	+0,7 0	31,5	0 -0,5
63/60	All types	35	+1 0	45	0 -1
125/100	All types	41	+1 0	53	0 -1

Dimensions in millimetres

The sketches are not intended to govern design except as regards the dimensions shown.

STANDARD SHEET 2-VIII

16/20 A AND 32/30 A SOCKET-OUTLETS
HAVING RATED OPERATING VOLTAGES NOT EXCEEDING 50 V

Bevelling of contact-tubes

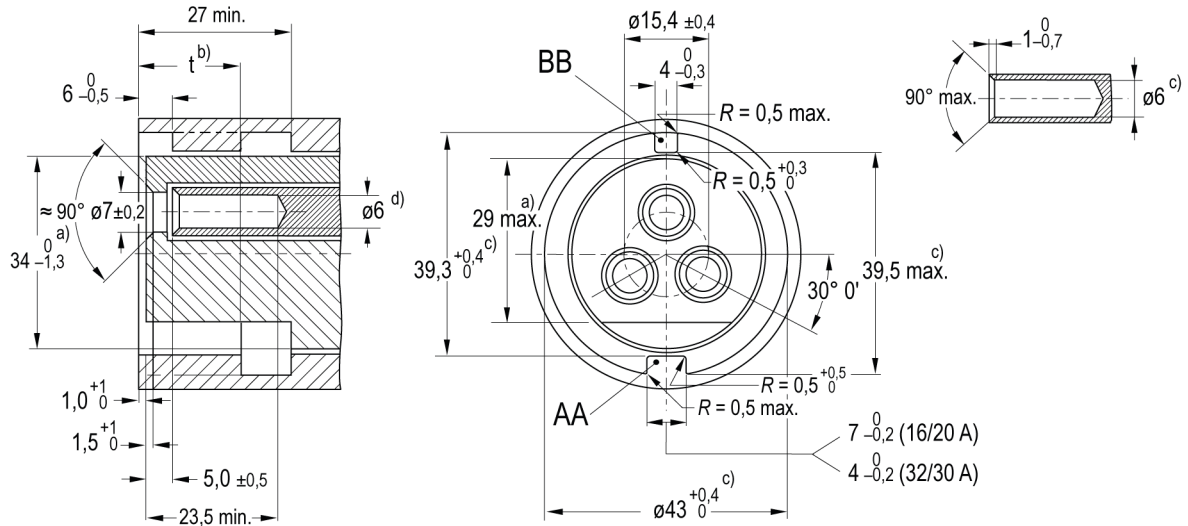

Key

- AA Major key
- BB Minor key

ARRANGEMENT OF CONTACT TUBES

Front view of contact tubes of socket-outlet

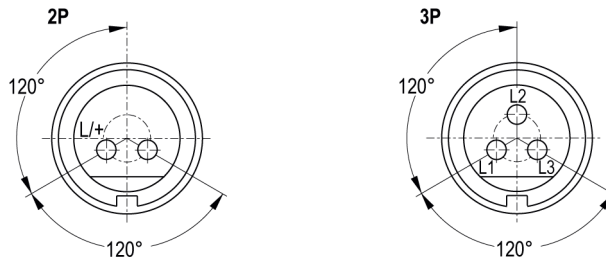

Dimensions in millimetres

- a) These dimensions shall be within the prescribed limits over a distance of 27 mm.
- b) The dimension t is 10 mm for a minor key of metal and 18 mm for a minor key of insulating material.
- c) These dimensions shall be within the prescribed limits over the distance t . Beyond this, they may be larger but not smaller.
- d) These dimensions refer to the pins; the contact tubes need not be circular.

STANDARD SHEET 2-VIII
(continuation 1)

RETAINING MEANS FOR SOCKET-OUTLETS

Lid or lever shown in engaged position

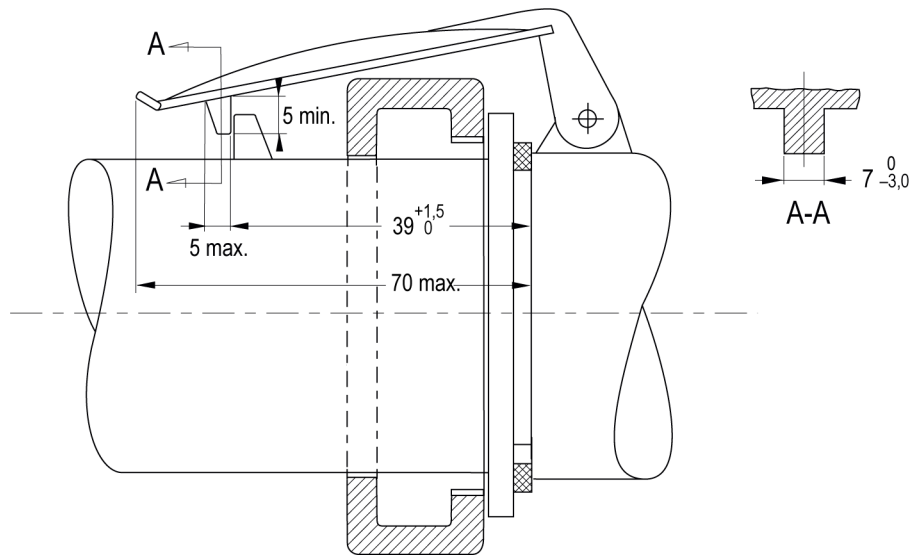

Dimensions in millimetres

For IP44 accessories, the retaining means shall be in the form of a lid such that IP66/IP67, IP67, IP67/IP69 and IP66/IP67/IP69 plugs or appliance inlets complying with standard sheet 2-IX and provided with a bayonet ring having maximum dimensions can be correctly introduced and retained.

STANDARD SHEET 2-VIII
(continuation 2)

RETAINING MEANS FOR SOCKET-OUTLETS

Example of cap with chain

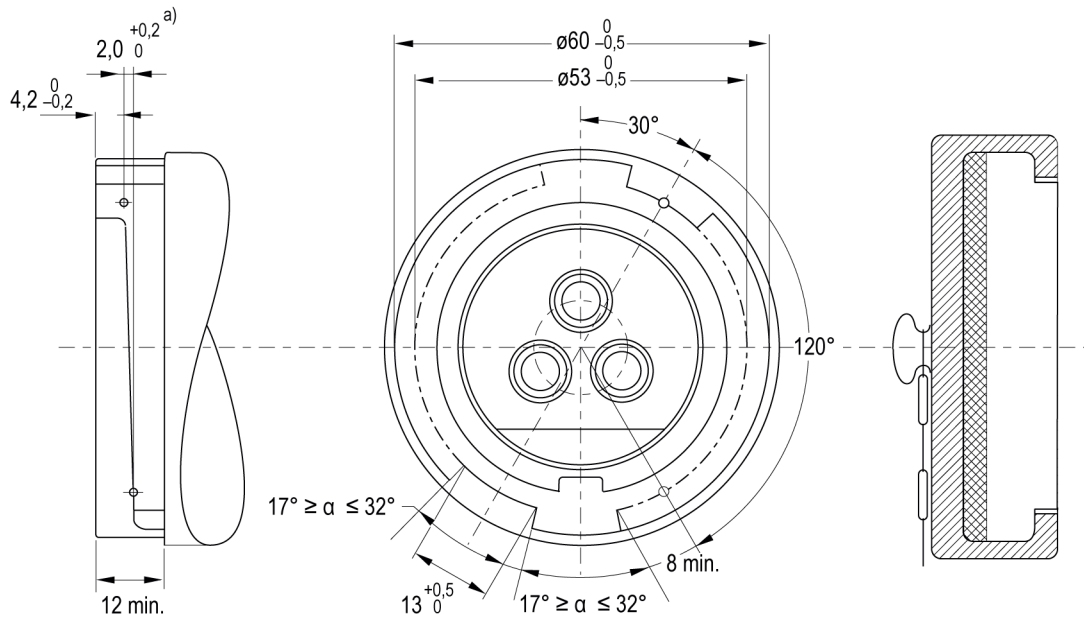

Dimensions in millimetres

a) The inclination of the ramps shall be such that this dimension refers to the angle of 120° shown.

The retaining means shall be in the form of bayonet ramps.

The sketches are not intended to govern design except as regards the dimensions shown.

STANDARD SHEET 2-VIIIa

SOCKET-OUTLETS FOR SPECIAL APPLICATION
HAVING RATED OPERATING VOLTAGES NOT EXCEEDING 50 V

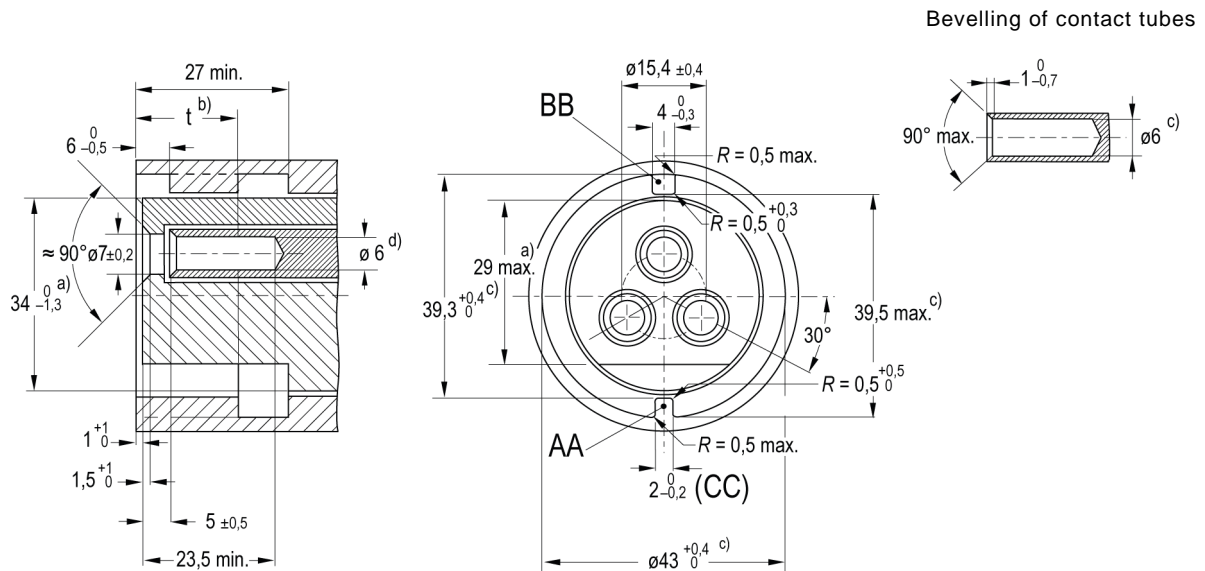

Key

- AA Major key
- BB Minor key
- CC For special applications

ARRANGEMENT OF CONTACT TUBES

Front view of contact tubes of socket-outlet

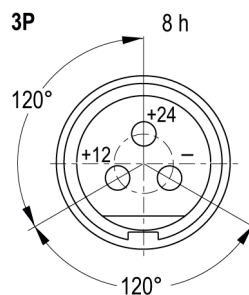

Dimensions in millimetres

- a) These dimensions shall be within the prescribed limits over a distance of 27 mm.
- b) The dimension t is 10 mm for a minor key of metal and 18 mm for a minor key of insulating material.
- c) These dimensions shall be within the prescribed limits over the distance t . Beyond this, they may be larger but not smaller.
- d) These dimensions refer to the pins; the contact tubes need not be circular.

STANDARD SHEET 2-IX

16/20 A AND 32/30 A PLUGS AND APPLIANCE INLETS
HAVING RATED OPERATING VOLTAGES NOT EXCEEDING 50 V

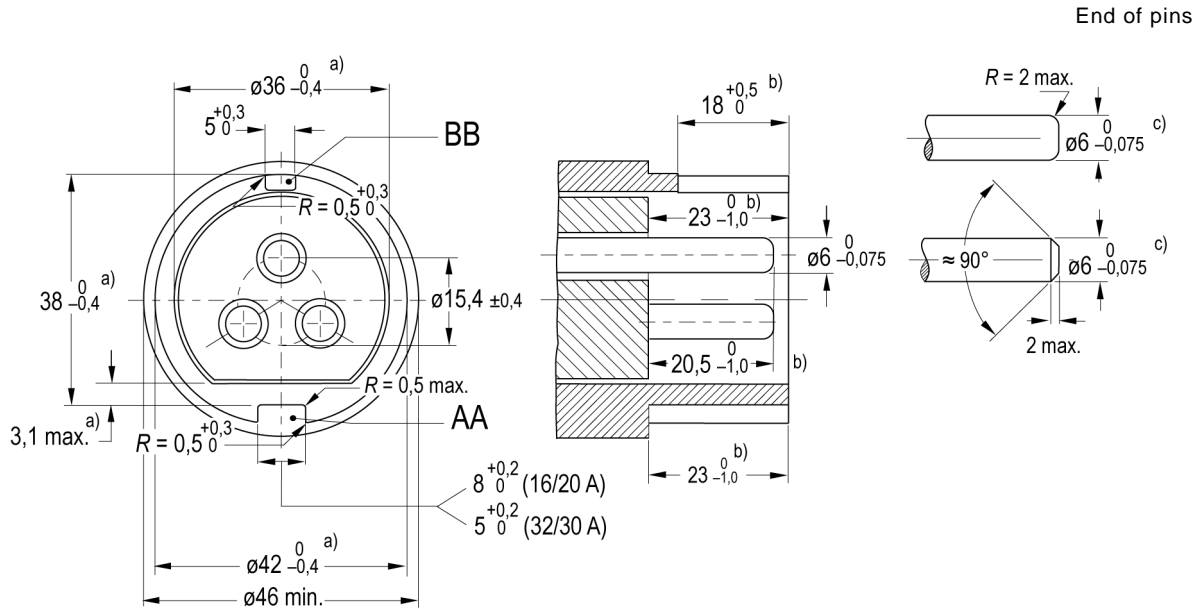

Key

- AA Major keyway
- BB Minor keyway

ARRANGEMENT OF PINS

Front view of pins of plug or appliance inlet

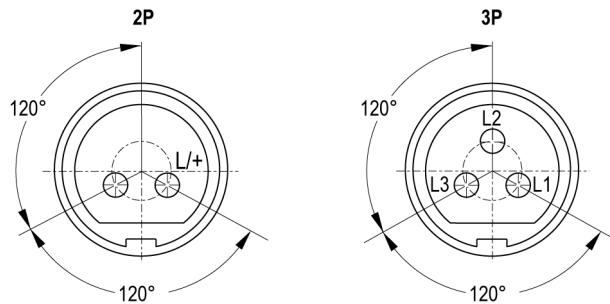

Dimensions in millimetres

- a) These dimensions shall be within the prescribed limits over a distance of:
26 mm for IP66/IP67, IP67, IP67/IP69 and IP66/IP67/IP69 accessories,
23 mm for other accessories.
- b) For IP66/IP67, IP67, IP67/IP69 and IP66/IP67/IP69 accessories, these dimensions are increased by 3,0 mm.
- c) This dimension shall be within the tolerances for the whole length of the pin.

STANDARD SHEET 2-IX
(continuation 1)

RETAINING MEANS FOR PLUGS AND APPLIANCE INLETS

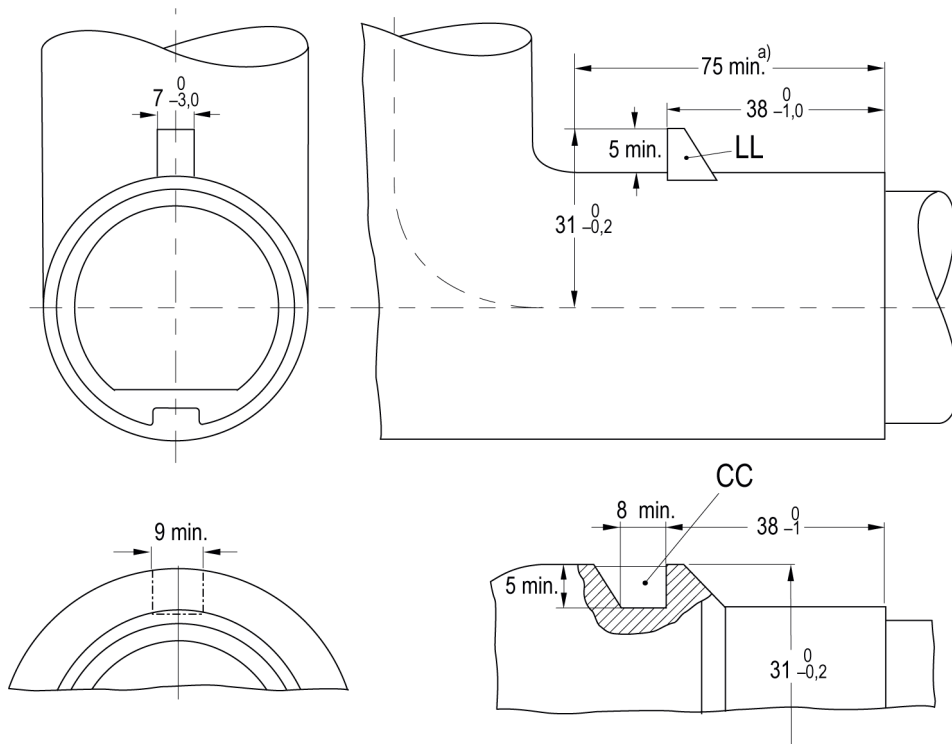

Dimensions in millimetres

a) Minimum clearance required for movement of hinged lid.

Key

CC Cavity

LL Lug

The retaining means shall be in the form of a lug or a cavity, at position 12 h.

STANDARD SHEET 2-IX
(continuation 2)

RETAINING MEANS FOR PLUGS AND APPLIANCE INLETS

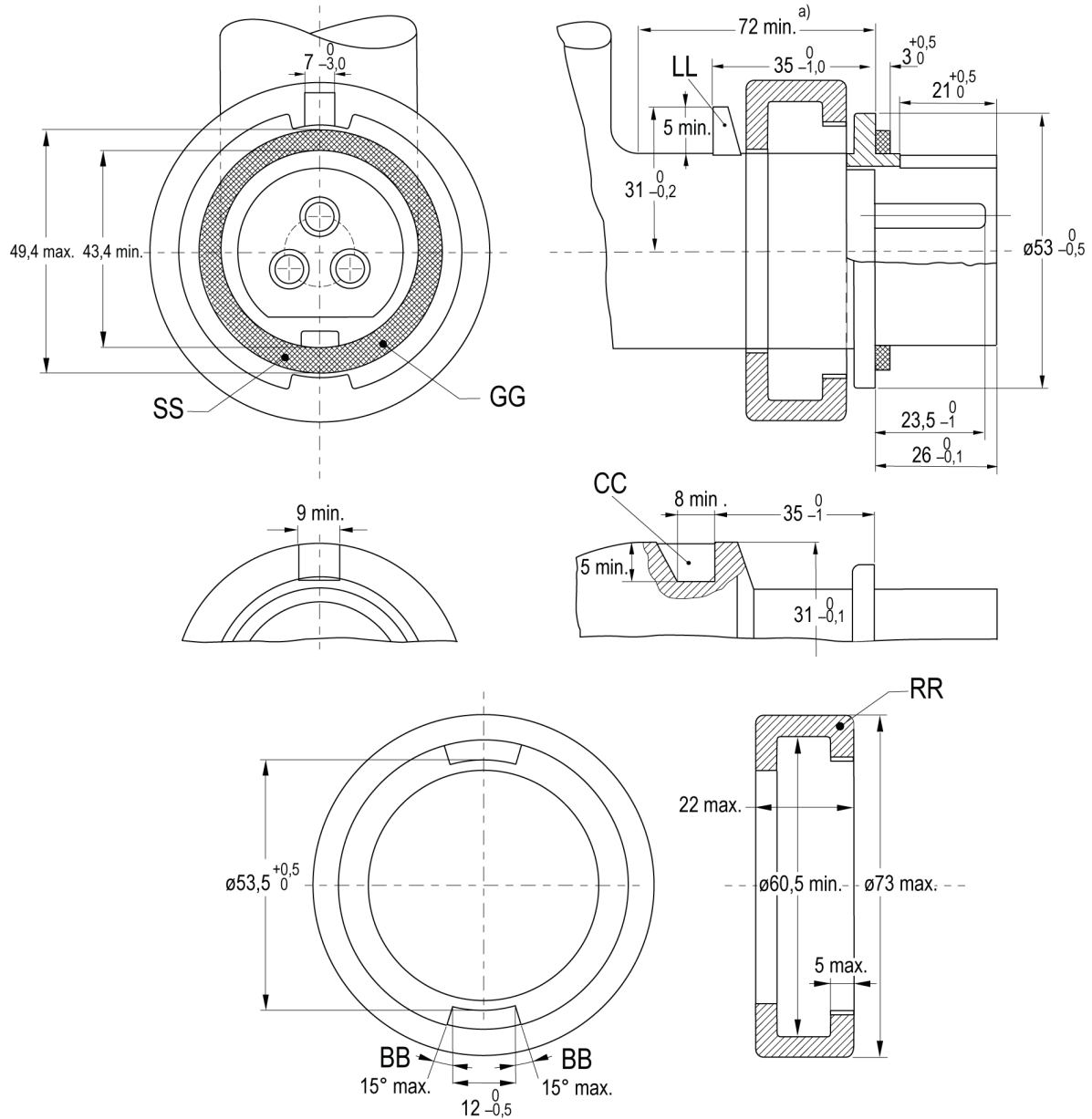

Dimensions in millimetres

a) Minimum clearance required for movement of hinged lid.

Key

- BB Bevel
- CC Cavity
- GG Gasket
- LL Lug
- RR Bayonet ring
- SS Sealing surface

The retaining means shall be in the form of a bayonet ring and a lug or a cavity, at position 12 h.

The sketches are not intended to govern design except as regards the dimensions shown.

STANDARD SHEET 2-IXa

PLUGS AND APPLIANCE INLETS HAVING RATED OPERATING VOLTAGES NOT EXCEEDING 50 V

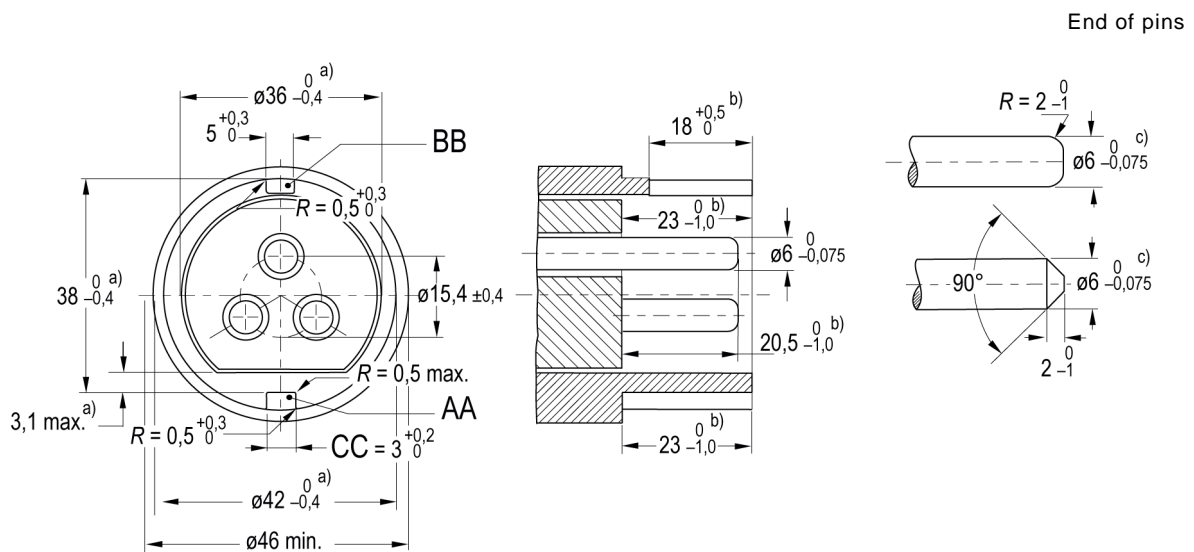

Key

- AA Major keyway
- BB Minor keyway
- CC (for special applications)

ARRANGEMENT OF PINS

Front view of pins of plug or appliance inlet

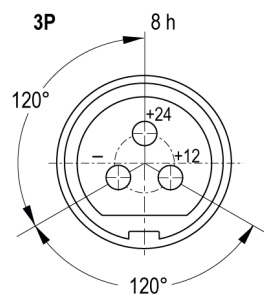

Dimensions in millimetres

- a) These dimensions shall be within the prescribed limits over a distance of:
 - 26 mm for IP66/IP67, IP67, IP67/IP69 and IP66/IP67/IP69 accessories,
 - 23 mm for other accessories.
- b) For IP66/IP67, IP67, IP67/IP69 and IP66/IP67/IP69 accessories, these dimensions are increased by 3,0 mm.
- c) This dimension shall be within the tolerances for the whole length of the pin.

Bibliography

ISO 1496-2:2018, *Series 1 freight containers – Specification and testing – Part 2: Thermal containers*

Bureau of Indian Standards

BIS is a statutory institution established under the *Bureau of Indian Standards Act, 2016* to promote harmonious development of the activities of standardization, marking and quality certification of goods and attending to connected matters in the country.

Copyright

BIS has the copyright of all its publications. No part of these publications may be reproduced in any form without the prior permission in writing of BIS. This does not preclude the free use, in the course of implementing the standard, of necessary details, such as symbols and sizes, type or grade designations. Enquiries relating to copyright be addressed to the Head (Publication & Sales), BIS.

Review of Indian Standards

Amendments are issued to standards as the need arises on the basis of comments. Standards are also reviewed periodically; a standard along with amendments is reaffirmed when such review indicates that no changes are needed; if the review indicates that changes are needed, it is taken up for revision. Users of Indian Standards should ascertain that they are in possession of the latest amendments or edition by referring to the website-www.bis.gov.in or www.standardsbis.in.

This Indian Standard has been developed from Doc No.: ETD 14 (22085).

Amendments Issued Since Publication

Amend No.	Date of Issue	Text Affected

BUREAU OF INDIAN STANDARDS

Headquarters:

Manak Bhavan, 9 Bahadur Shah Zafar Marg, New Delhi 110002

Telephones: 2323 0131, 2323 3375, 2323 9402

Website: www.bis.gov.in

Regional Offices:

	Telephones
Central : 601/A, Konnectus Tower -1, 6 th Floor, DMRC Building, Bhavbhuti Marg, New Delhi 110002	{ 2323 7617
Eastern : 8 th Floor, Plot No 7/7 & 7/8, CP Block, Sector V, Salt Lake, Kolkata, West Bengal 700091	{ 2367 0012 2320 9474
Northern : Plot No. 4-A, Sector 27-B, Madhya Marg, Chandigarh 160019	{ 265 9930
Southern : C.I.T. Campus, IV Cross Road, Taramani, Chennai 600113	{ 2254 1442 2254 1216
Western : Plot No. E-9, Road No.-8, MIDC, Andheri (East), Mumbai 400093	{ 2821 8093

Branches : AHMEDABAD. BENGALURU. BHOPAL. BHUBANESHWAR. CHANDIGARH. CHENNAI. COIMBATORE. DEHRADUN. DELHI. FARIDABAD. GHAZIABAD. GUWAHATI. HIMACHAL PRADESH. HUBLI. HYDERABAD. JAIPUR. JAMMU & KASHMIR. JAMSHEDPUR. KOCHI. KOLKATA. LUCKNOW. MADURAI. MUMBAI. NAGPUR. NOIDA. PANIPAT. PATNA. PUNE. RAIPUR. RAJKOT. SURAT. VISAKHAPATNAM.