

TECHNICAL REPORT



High-voltage direct current (HVDC) power transmission using voltage sourced converters (VSC)





THIS PUBLICATION IS COPYRIGHT PROTECTED

Copyright © 2022 IEC, Geneva, Switzerland

All rights reserved. Unless otherwise specified, no part of this publication may be reproduced or utilized in any form or by any means, electronic or mechanical, including photocopying and microfilm, without permission in writing from either IEC or IEC's member National Committee in the country of the requester. If you have any questions about IEC copyright or have an enquiry about obtaining additional rights to this publication, please contact the address below or your local IEC member National Committee for further information.

IEC Secretariat
3, rue de Varembe
CH-1211 Geneva 20
Switzerland

Tel.: +41 22 919 02 11
info@iec.ch
www.iec.ch

About the IEC

The International Electrotechnical Commission (IEC) is the leading global organization that prepares and publishes International Standards for all electrical, electronic and related technologies.

About IEC publications

The technical content of IEC publications is kept under constant review by the IEC. Please make sure that you have the latest edition, a corrigendum or an amendment might have been published.

IEC publications search - webstore.iec.ch/advsearchform

The advanced search enables to find IEC publications by a variety of criteria (reference number, text, technical committee, ...). It also gives information on projects, replaced and withdrawn publications.

IEC Just Published - webstore.iec.ch/justpublished

Stay up to date on all new IEC publications. Just Published details all new publications released. Available online and once a month by email.

IEC Customer Service Centre - webstore.iec.ch/csc

If you wish to give us your feedback on this publication or need further assistance, please contact the Customer Service Centre: sales@iec.ch.

IEC Products & Services Portal - products.iec.ch

Discover our powerful search engine and read freely all the publications previews. With a subscription you will always have access to up to date content tailored to your needs.

Electropedia - www.electropedia.org

The world's leading online dictionary on electrotechnology, containing more than 22 300 terminological entries in English and French, with equivalent terms in 19 additional languages. Also known as the International Electrotechnical Vocabulary (IEV) online.

TECHNICAL REPORT



High-voltage direct current (HVDC) power transmission using voltage sourced converters (VSC)

INTERNATIONAL
ELECTROTECHNICAL
COMMISSION

ICS 29.200; 29.240.99

ISBN 978-2-8322-4546-0

Warning! Make sure that you obtained this publication from an authorized distributor.

CONTENTS

FOREWORD	6
1 Scope	8
2 Normative references	8
3 Terms and definitions	8
3.1 General.....	9
3.2 Letter symbols	11
3.3 VSC transmission	11
3.4 Power losses	12
4 VSC transmission overview	11
4.1 Basic operating principles of VSC transmission.....	13
4.1.1 Voltage sourced converter as a black box.....	13
4.1.2 Principles of active and reactive power control	14
4.1.3 Operating principles of a VSC transmission scheme	16
4.1.4 Applications of VSC transmission	17
4.2 Design life.....	17
4.3 VSC transmission configurations.....	17
4.3.1 General	17
4.3.2 DC circuit configurations.....	18
4.3.3 Monopole configuration	18
4.3.4 Bipolar configuration.....	19
4.3.5 Parallel connection of two converters	20
4.3.6 Series connection of two converters	21
4.3.7 Parallel and series connection of more than two converters	21
4.4 Semiconductors for VSC transmission	21
5 VSC transmission converter topologies.....	23
5.1 General.....	23
5.2 Converter topologies with VSC valves of switch type	23
5.2.1 General	23
5.2.2 Operating principle	24
5.2.3 Topologies.....	24
5.3 Converter topologies with VSC valves of the controllable voltage source type.....	28
5.3.1 General	28
5.3.2 MMC topology with VSC levels in half-bridge topology.....	30
5.3.3 MMC topology with VSC levels in full-bridge topology.....	32
5.3.4 CTL topology with VSC cells in half-bridge topology	33
5.3.5 CTL topology with VSC cells in full-bridge topology	33
5.4 VSC valve design considerations	33
5.4.1 Reliability and failure mode.....	33
5.4.2 Current rating	34
5.4.3 Transient current and voltage requirements	34
5.4.4 Diode requirements	34
5.4.5 Additional design details.....	35
5.5 Other converter topologies.....	35
5.6 Other equipment for VSC transmission schemes.....	36
5.6.1 General	36
5.6.2 Power components of a VSC transmission scheme.....	36

5.6.3	VSC substation circuit breaker.....	36
5.6.4	AC system side harmonic filters.....	36
5.6.5	Radio frequency interference filters.....	37
5.6.6	Interface transformers and phase reactors.....	37
5.6.7	Valve reactor.....	38
5.6.8	DC capacitors.....	38
5.6.9	DC reactor.....	40
5.6.10	Common mode blocking reactor.....	40
5.6.10	DC filter.....	40
5.6.11	Dynamic braking system.....	40
6	Overview of VSC controls.....	41
6.1	General.....	41
6.2	Operational modes and operational options.....	42
6.3	Power transfer.....	43
6.3.1	General.....	43
6.3.2	Telecommunication between converter stations.....	44
6.4	Reactive power and AC voltage control.....	44
6.4.1	AC voltage control.....	44
6.4.2	Reactive power control.....	44
6.5	Black start capability.....	45
6.6	Supply from a wind farm.....	45
7	Steady-state operation.....	45
7.1	Steady-state capability.....	45
7.2	Converter power losses.....	47
8	Dynamic performance.....	47
8.1	AC system disturbances.....	47
8.2	DC system disturbances.....	48
8.2.1	DC cable fault.....	48
8.2.2	DC overhead line fault.....	48
8.3	Internal faults.....	48
9	HVDC performance requirements.....	49
9.1	Harmonic performance.....	49
9.2	Wave distortion.....	50
9.3	Fundamental and harmonics.....	50
9.3.1	Three-phase 2-level VSC.....	50
9.3.2	Multi-pulse and multi-level converters.....	51
9.4	Harmonic voltages on power systems due to VSC operation.....	51
9.5	Design considerations for harmonic filters (AC side).....	52
9.6	DC side filtering.....	52
10	Environmental impact.....	52
10.1	General.....	52
10.2	Audible noise.....	52
10.3	Electric and magnetic fields (EMF).....	53
10.4	Electromagnetic compatibility (EMC).....	53
11	Testing and commissioning.....	54
11.1	General.....	54
11.2	Factory tests.....	54
11.2.1	Component tests.....	54

11.2.2	Control system tests	54
11.3	Commissioning tests/system tests.....	55
11.3.1	General	55
11.3.2	Precommissioning tests	55
11.3.3	Subsystem tests	55
11.3.4	System tests.....	55
Annex A (informative) Functional specification requirements for VSC transmission systems		60
A.1	Introduction General	60
A.2	Purchaser and manufacturer information requirements	60
A.2.1	General	60
A.2.2	General requirements	61
A.2.3	Detailed descriptions	62
Annex B (informative) Modulation strategies for 2-level converters		66
B.1	Carrier wave PWM	66
B.2	Selective harmonic elimination modulation.....	67
Bibliography.....		69
Figure 1 – Major components that may can be found in a VSC substation.....		10
Figure 2 – Diagram of a generic voltage source converter.....		13
Figure 3 – Principle of active power control.....		15
Figure 4 – Principle of reactive power control		16
Figure 5 – A point-to-point VSC transmission scheme.....		16
Figure 6 – VSC transmission with a symmetrical monopole.....		18
Figure 7 – VSC transmission with an asymmetrical monopole with metallic return.....		18
Figure 8 – VSC transmission with an asymmetrical monopole with earth return.....		19
Figure 9 – VSC transmission in bipolar configuration with earth return.....		19
Figure 10 – VSC transmission in bipolar configuration with dedicated metallic return		20
Figure 11 – VSC transmission in rigid bipolar configuration.....		20
Figure 12 – Parallel connection of two converter units		21
Figure 13 – Symbol of a turn-off semiconductor device and associated free-wheeling diode		22
Figure 14 – Symbol of an IGBT and associated free-wheeling diode		22
Figure 15 – Diagram of a three-phase 2-level converter and associated AC waveform for one phase.....		25
Figure 16 – Single-phase AC output for 2-level converter with PWM switching at 21 times fundamental frequency		26
Figure 17 – Diagram of a three-phase 3-level NPC converter and associated AC waveform for one phase.....		27
Figure 18 – Single-phase AC output for 3-level NPC converter with PWM switching at 21 times fundamental frequency		28
Figure 19 – Electrical equivalent for a converter with VSC valves acting like a controllable voltage source		29
Figure 20 – VSC valve level arrangement and equivalent circuit in MMC topology in half-bridge topology		30
Figure 21 – Converter block arrangement with MMC topology in half-bridge topology		32

Figure 22 – VSC valve level arrangement and equivalent circuit in MMC topology with full-bridge topology 32

Figure 23 – Typical SSOA for the IGBT 34

Figure 24 – A 2-level VSC bridge with the IGBTs turned off 34

Figure 25 – Representing a VSC unit as an AC voltage of magnitude U and phase angle δ behind reactance 41

Figure 26 – Concept of vector control 43

Figure 27 – VSC power controller 43

Figure 28 – AC voltage controller 44

Figure 29 – A typical simplified PQ diagram 46

Figure 30 – Protection concept of a VSC substation 49

Figure 31 – Waveforms for three-phase 2-level VSC 51

Figure 32 – Equivalent circuit at the PCC of the VSC 51

Figure B.1 – Voltage harmonics spectra of a 2-level VSC with carrier frequency at 21st harmonic 67

Figure B.2 – Phase output voltage for selective harmonic elimination modulation (SHEM) 68

INTERNATIONAL ELECTROTECHNICAL COMMISSION

**HIGH-VOLTAGE DIRECT CURRENT (HVDC) POWER
TRANSMISSION USING VOLTAGE SOURCED CONVERTERS (VSC)****FOREWORD**

- 1) The International Electrotechnical Commission (IEC) is a worldwide organization for standardization comprising all national electrotechnical committees (IEC National Committees). The object of IEC is to promote international co-operation on all questions concerning standardization in the electrical and electronic fields. To this end and in addition to other activities, IEC publishes International Standards, Technical Specifications, Technical Reports, Publicly Available Specifications (PAS) and Guides (hereafter referred to as "IEC Publication(s)"). Their preparation is entrusted to technical committees; any IEC National Committee interested in the subject dealt with may participate in this preparatory work. International, governmental and non-governmental organizations liaising with the IEC also participate in this preparation. IEC collaborates closely with the International Organization for Standardization (ISO) in accordance with conditions determined by agreement between the two organizations.
- 2) The formal decisions or agreements of IEC on technical matters express, as nearly as possible, an international consensus of opinion on the relevant subjects since each technical committee has representation from all interested IEC National Committees.
- 3) IEC Publications have the form of recommendations for international use and are accepted by IEC National Committees in that sense. While all reasonable efforts are made to ensure that the technical content of IEC Publications is accurate, IEC cannot be held responsible for the way in which they are used or for any misinterpretation by any end user.
- 4) In order to promote international uniformity, IEC National Committees undertake to apply IEC Publications transparently to the maximum extent possible in their national and regional publications. Any divergence between any IEC Publication and the corresponding national or regional publication shall be clearly indicated in the latter.
- 5) IEC itself does not provide any attestation of conformity. Independent certification bodies provide conformity assessment services and, in some areas, access to IEC marks of conformity. IEC is not responsible for any services carried out by independent certification bodies.
- 6) All users should ensure that they have the latest edition of this publication.
- 7) No liability shall attach to IEC or its directors, employees, servants or agents including individual experts and members of its technical committees and IEC National Committees for any personal injury, property damage or other damage of any nature whatsoever, whether direct or indirect, or for costs (including legal fees) and expenses arising out of the publication, use of, or reliance upon, this IEC Publication or any other IEC Publications.
- 8) Attention is drawn to the Normative references cited in this publication. Use of the referenced publications is indispensable for the correct application of this publication.
- 9) Attention is drawn to the possibility that some of the elements of this IEC Publication may be the subject of patent rights. IEC shall not be held responsible for identifying any or all such patent rights.

This redline version of the official IEC Standard allows the user to identify the changes made to the previous edition IEC TR 62543:2011+AMD1:2013+AMD2:2017 CSV. A vertical bar appears in the margin wherever a change has been made. Additions are in green text, deletions are in strikethrough red text.

IEC TR 62543 has been prepared by subcommittee 22F: Power electronics for electrical transmission and distribution systems, of IEC technical committee 22: Power electronic systems and equipment. It is a Technical Report.

This second edition cancels and replaces the first edition published in 2011, Amendment 1:2013 and Amendment 2:2017. This edition constitutes a technical revision.

This edition includes the following significant technical changes with respect to the previous edition:

- a) in Clause 3, some redundant definitions which were identical to those listed in IEC 62747 have been deleted;
- b) in 4.3.4, description and diagrams have been added for the cases of a bipole with dedicated metallic return and a rigid bipole;
- c) in 4.4, mention is made of the bi-mode insulated gate transistor (BiGT) and injection enhanced gate transistor (IEGT) as possible alternatives to the IGBT;
- d) in 5.6, the reference to common-mode blocking reactors has been deleted since these are very rarely used nowadays.

The text of this Technical Report is based on the following documents:

Draft	Report on voting
22F/649/DTR	22F/669/RVDTR

Full information on the voting for its approval can be found in the report on voting indicated in the above table.

The language used for the development of this Technical Report is English.

This document was drafted in accordance with ISO/IEC Directives, Part 2, and developed in accordance with ISO/IEC Directives, Part 1 and ISO/IEC Directives, IEC Supplement, available at www.iec.ch/members_experts/refdocs. The main document types developed by IEC are described in greater detail at www.iec.ch/publications.

The committee has decided that the contents of this document will remain unchanged until the stability date indicated on the IEC website under webstore.iec.ch in the data related to the specific document. At this date, the document will be

- reconfirmed,
- withdrawn,
- replaced by a revised edition, or
- amended.

IMPORTANT – The "colour inside" logo on the cover page of this document indicates that it contains colours which are considered to be useful for the correct understanding of its contents. Users should therefore print this document using a colour printer.

HIGH-VOLTAGE DIRECT CURRENT (HVDC) POWER TRANSMISSION USING VOLTAGE SOURCED CONVERTERS (VSC)

1 Scope

This document gives general guidance on the subject of voltage sourced converters (VSC) used for transmission of power by high voltage direct current (HVDC). It describes converters that are not only voltage sourced (containing a capacitive energy storage medium and where the polarity of DC voltage remains fixed) but also self-commutated, using semiconductor devices which can both be turned on and turned off by control action. The scope includes 2-level and 3-level converters with pulse-width modulation (PWM), along with multi-level converters, modular multi-level converters and cascaded two-level converters, but excludes 2-level and 3-level converters operated without PWM, in square-wave output mode.

HVDC power transmission using voltage sourced converters is known as "VSC transmission".

The various types of circuit that can be used for VSC transmission are described in this document, along with their principal operational characteristics and typical applications. The overall aim is to provide a guide for purchasers to assist with the task of specifying a VSC transmission scheme.

Line-commutated and current-sourced converters are specifically excluded from this document.

2 Normative references

The following referenced documents are indispensable for the application of this document. For dated references, only the edition cited applies. For undated references, the latest edition of the referenced document (including any amendments) applies.

~~IEC 61975, High-voltage direct current (HVDC) installations – System tests~~

IEC 62501, *Voltage sourced converter (VSC) valves for high-voltage direct current (HVDC) power transmission – Electrical testing*

IEC 62747, *Terminology for voltage-sourced converters (VSC) for high-voltage direct current (HVDC) systems*

~~IEC 62751 (all parts), Power losses in voltage sourced converter (VSC) valves for high voltage direct current (HVDC) systems~~

3 Terms and definitions

For the purposes of this document, the terms and definitions given in IEC 62747, IEC 62501 and the following apply.

ISO and IEC maintain terminological databases for use in standardization at the following addresses:

- IEC Electropedia: available at <http://www.electropedia.org/>
- ISO Online browsing platform: available at <http://www.iso.org/obp>

3.1 General

Basic terms and definitions for voltage sourced converters used for HVDC transmission are given in IEC 62747. Terminology on electrical testing of VSC valves for HVDC transmission is given in IEC 62501.

To support the explanations, Figure 1 presents the basic diagram of a VSC system. Dependent on the converter topology and the requirements in the project, some components can be omitted or can differ.

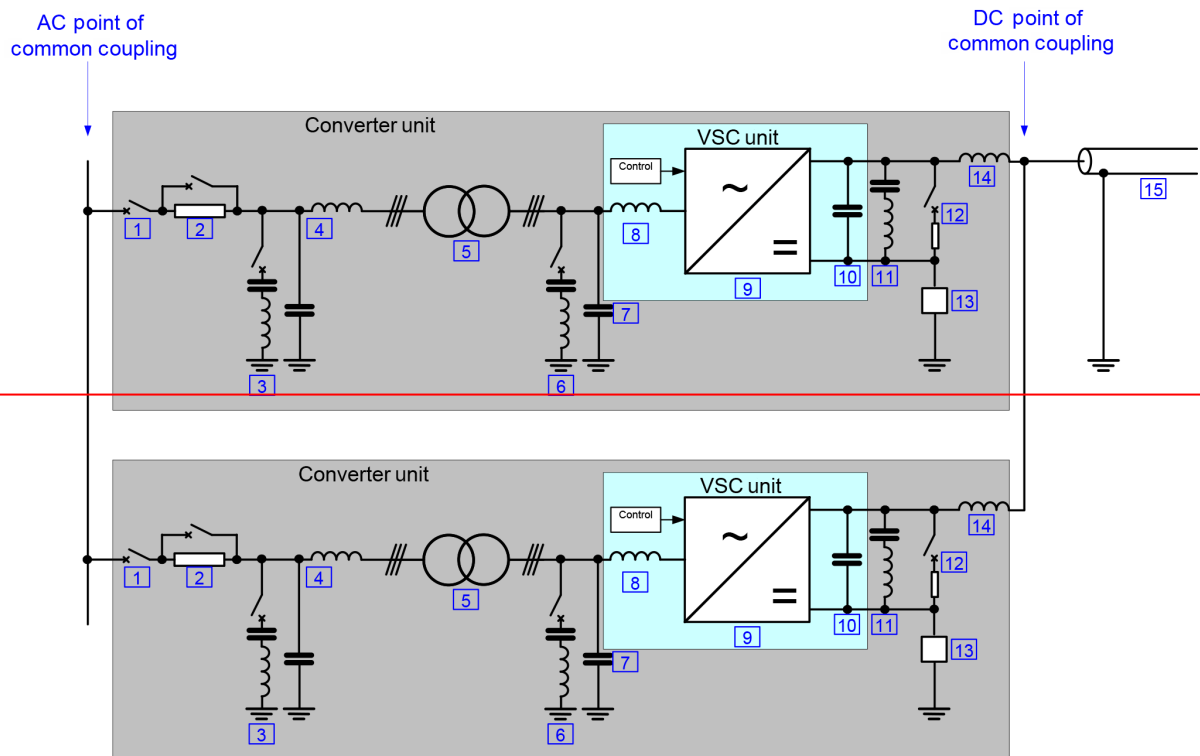

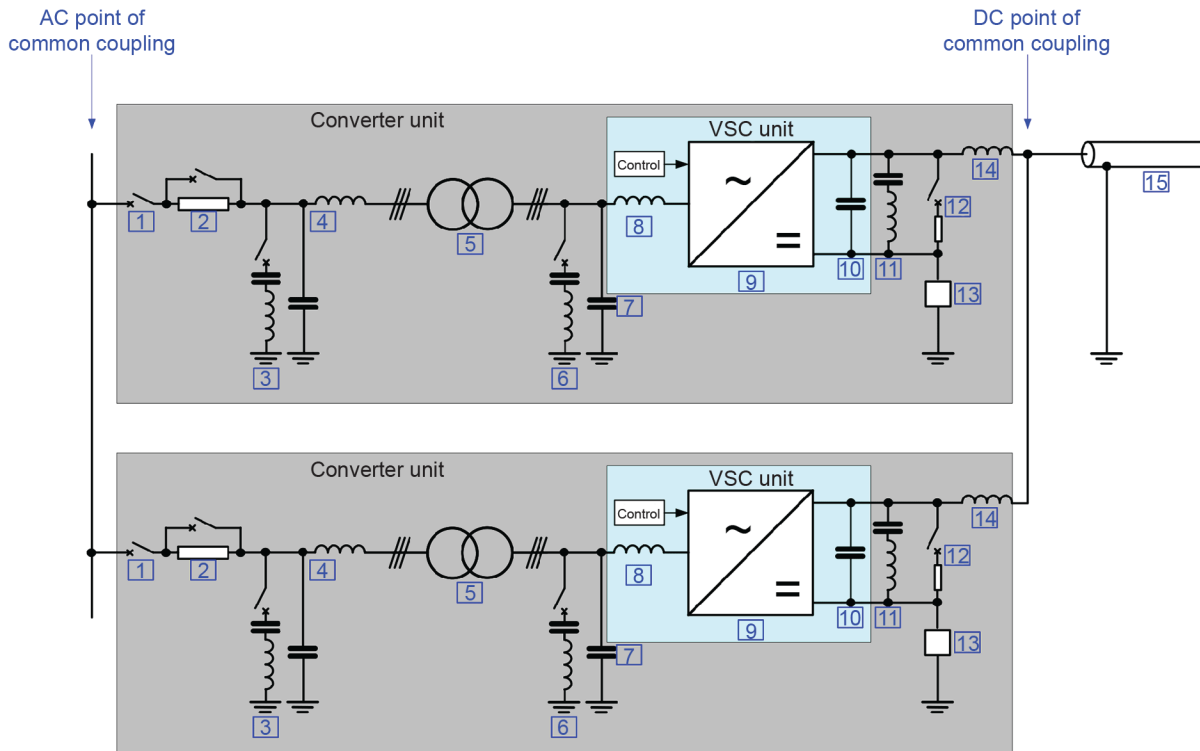

IEC

Key

- | | | | |
|-------|--|----|--|
| 1 | circuit breaker | 9 | VSC unit ³⁾ |
| 2 | pre-insertion resistor | 10 | VSC DC capacitor ⁴⁾ |
| 3 | line side harmonic filter ¹⁾ | 11 | DC harmonic filter ¹⁾ |
| 4 | line side high frequency filter ⁶⁾ | 12 | dynamic braking system ⁷⁾ |
| 5 | interface transformer | 13 | neutral point grounding branch ⁵⁾ |
| 6 | converter side harmonic filter ¹⁾ | 14 | DC reactor ⁸⁾ |
| 7 + 8 | converter side high frequency filter ²⁾ | 15 | DC cable or overhead transmission line |
| 8 | phase reactor ²⁾ | | |

- 1) In some designs of VSC based on controllable voltage source valves, it is possible the harmonic filters ~~may~~ is not ~~be~~ required.
- 2) In some designs of VSC, the phase reactor ~~may fulfill~~ can fulfil part of the function of the converter-side high frequency filter.
- 3) In some VSC topologies, each valve of the VSC unit ~~may~~ can include a "valve reactor", which ~~may~~ can be built into the valve or provided as a separate component.
- 4) In some designs of VSC, the VSC DC capacitor ~~may~~ can be partly or entirely distributed amongst the three-phase units of the VSC unit, where it is referred to as the DC submodule capacitors.
- 5) The philosophy and location of the neutral point grounding branch ~~may~~ can be different depending on the design of the VSC unit.
- 6) In some designs of VSC, the interface transformer ~~may fulfill~~ can fulfil part of the function of the line-side high frequency filter.
- 7) Optional.
- 8) Optional, ~~if phase reactors are located on the d.c. side of the converter.~~

Figure 1 – Major components that ~~may~~ can be found in a VSC substation

3.2 Letter symbols

U_{conv}	line-to-line AC voltage of the converter unit(s), RMS value, including harmonics
I_{conv}	alternating current of the converter unit(s), RMS value, including harmonics
U_{L}	line-to-line AC voltage of the AC system, RMS value, including harmonics
I_{L}	alternating current of the AC system, RMS value, including harmonic
U_{d}	d.c. line-to-line voltage of the d.c. bus of the VSC transmission system;
U_{dc}	DC terminal-to-terminal voltage of one converter unit
I_{d}	DC current of the DC bus of the VSC transmission system

3.3 VSC transmission

3.3.1

VSC DC capacitor

capacitor bank(s) (if any) connected between two DC terminals of the VSC, used for energy storage and/or filtering purposes

3.3.2

AC side radio frequency interference filter

RFI filter

filters (if any) used to reduce penetration of radio frequency interference (RFI) into the AC system to an acceptable level

3.3.3

~~valve side harmonic filter~~ converter side high frequency filter

filters (if any) used to mitigate the HF stresses of the interface transformer

~~3.5.10~~

~~d.c. harmonic filter~~

~~d.c. filters (if any) used to prevent harmonics generated by VSC valve from penetrating into the d.c. system.~~

~~NOTE The filter can consist of a tuned shunt branch, smoothing reactor or common mode blocking reactor or combinations thereof.~~

~~3.5.11~~

~~d.c. reactor~~

~~a reactor (if any) connected in series to a d.c. busbar~~

~~NOTE DC reactor is used to reduce harmonic currents flowing in the d.c. line or cable and to detune critical resonances within the d.c. circuit. A d.c. reactor might also be used for protection purposes.~~

3.3.4

DC side radio frequency interference filter

filters (if any) used to reduce penetration of radio frequency (RF) into the DC system to acceptable limits

3.3.5

type tests

tests carried out to verify that the components of VSC transmission system design will meet the requirements specified

Note 1 to entry: In this document, type tests are classified under two major categories: dielectric tests and operational tests.

3.3.6

dielectric tests

tests carried out to verify the high voltage withstanding capability of the components of VSC transmission system

3.3.7

operational tests

tests carried out to verify the turn-on (if applicable), turn-off (if applicable), and current related capabilities of the components of VSC transmission system

3.3.8

production tests

tests carried out to verify proper manufacture, so that the properties of the certain component of VSC transmission system correspond to those specified

3.3.9

sample tests

production tests which are carried out on a small number of certain VSC transmission components, for example valve sections or special components taken at random from a batch

3.4 Power losses

3.4.1

auxiliary losses

electric power required to feed the VSC substation auxiliary loads

Note 1 to entry: The auxiliary losses depend on whether the substation is in no-load or carrying load, in which case the auxiliary losses depend on the load level.

3.4.2

no-load operating losses

losses produced in an item of equipment with the VSC substation energized but with the VSCs blocked and all substation service loads and auxiliary equipment connected as required for immediate pick-up of load

3.4.3

idling operating losses

losses produced in an item of equipment with the VSC substation energized and with the VSCs de-blocked but with no real or reactive power output

3.4.4

operating losses

losses produced in an item of equipment at a given load level with the VSC substation energized and the converters operating

3.4.5

total system losses

sum of all operating losses, including the corresponding auxiliary losses

3.4.6

station essential auxiliary load

loads whose failure will affect the conversion capability of the HVDC converter station (e.g. valve cooling), as well as the loads that ~~shall~~ need to remain working in case of complete loss of AC power supply (e.g. battery chargers, operating mechanisms)

Note 1 to entry: Total "operating losses" minus "no-load operating losses" ~~may~~ can be considered as being quantitatively equivalent to "load losses" as in conventional AC substation practice.

4 VSC transmission overview

4.1 Basic operating principles of VSC transmission

4.1.1 Voltage sourced converter as a black box

The operation of a voltage sourced converter is described in greater detail in Clause 5. In 4.1, the converter is treated as a black box that can convert from AC to DC and vice versa, and only steady-state operation is considered.

Figure 2 depicts a schematic diagram of a generic voltage sourced converter connected to a DC circuit on one side and to an AC circuit on the other.

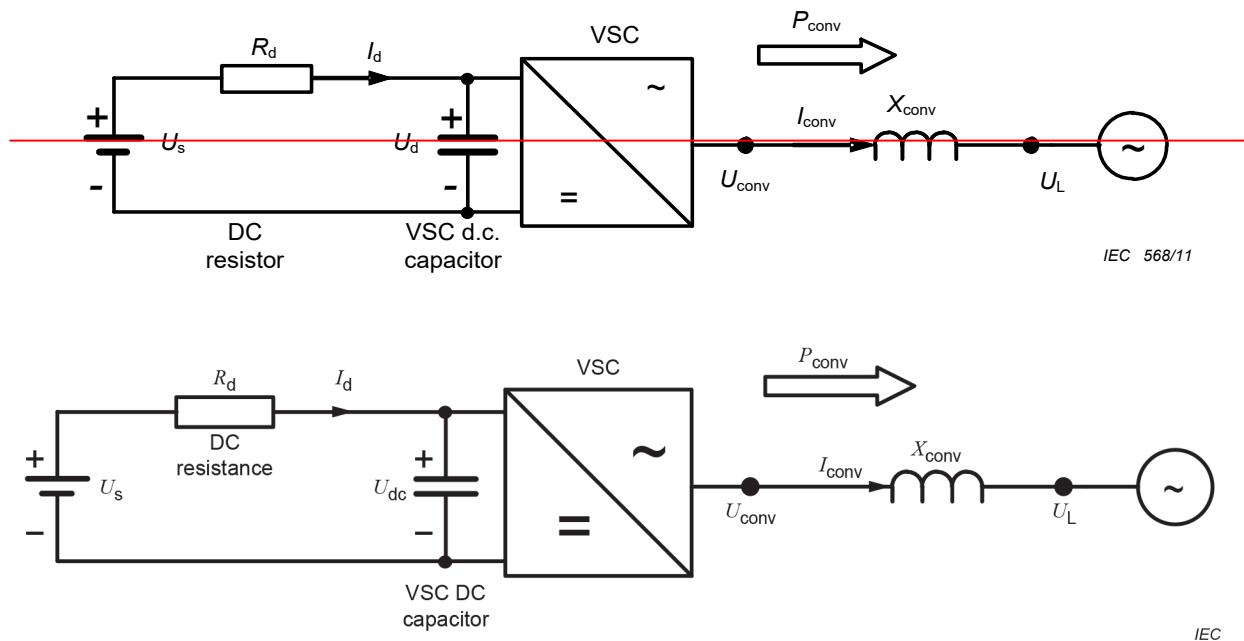

NOTE AC filters are not shown.

Figure 2 – Diagram of a generic voltage source converter

The VSC can be operated as either an inverter, injecting real power into the AC network ($I_d \times U_d > 0$), or as a rectifier absorbing power from the AC network ($I_d \times U_d < 0$). Similarly, the VSC can be operated either capacitively, injecting reactive power into the AC network ($\text{Im}(U_L \cdot I_L) > 0$), or inductively, absorbing reactive power from the AC network ($\text{Im}(U_L \cdot I_L) < 0$). The VSC can be operated capacitively or inductively in both the inverter and the rectifier mode.

The designation voltage sourced converter is used because the function of the VSC is predicated on the connection of a voltage source on the DC side.

To the left in Figure 2, a DC voltage source U_s is shown with a DC resistor R_d representing the DC circuit resistance, and a DC capacitor connected. The DC shunt capacitor serves the purpose of stabilizing the DC voltage U_d . Depending on the VSC converter topology, the DC storage capacitor is realized either as a central DC storage capacitor between both poles or as multiple storage capacitors distributed within the converter phase units. The conversion from DC to AC takes place in the VSC as explained in Clause 5.

On the AC side, an interface inductance X_{conv} is provided which serves two purposes: first, it stabilizes the AC current, and secondly, it enables the control of active and reactive output power from the VSC, as explained in 4.1.2. The interface inductance can be

implemented as reactors, as leakage inductances in transformers, or as a combination thereof. The DC capacitor on the input side and the AC interface inductance on the output side are important components for the proper functioning of a VSC.

A passive or active AC network can be connected on the AC side of the VSC. If the VSC is connected to a passive network on its AC side, the power flow can be only from the DC input side towards the passive load on the AC side. However, if the AC side is connected to an active AC network, the power flow can be in both directions by controlling the AC voltage output U_{conv} of the VSC.

By controlling the phase angle of U_{conv} , the active power through the VSC can be controlled as explained in 4.1.2.2. By controlling the voltage amplitude of U_{conv} , the reactive power through the VSC can be controlled as explained in 4.1.2.3.

4.1.2 Principles of active and reactive power control

4.1.2.1 General

The VSC can be considered as an equivalent of a synchronous generator without inertia, which has the capability of individually controlling active and reactive power.

The exchange of active and reactive power between a VSC and the AC grid is controlled by the phase angle and amplitude of the VSC output voltage in relation to the voltage of the AC grid.

The active and reactive power are related to the AC voltages U_L and U_{conv} of the AC system and converter respectively, the reactance X between these voltages and the phase angle δ between them, according to the following:

$$P = \frac{U_L \times U_{\text{conv}} \times \sin \delta}{X}$$

$$Q = \frac{U_L \times (U_L - U_{\text{conv}} \times \cos \delta)}{X}$$

If U_{conv} is in phase with the line voltage U_L and its amplitude is equal to U_L , there is no AC current I_{conv} from the VSC. Under these conditions, the DC current I_d becomes zero and the DC capacitor voltage U_d becomes equal to the DC source voltage U_s .

4.1.2.2 Principle of active power control

The principle of active power control is depicted in Figure 3, where the active power through the interface inductance is controlled by regulating the VSC voltage angle.

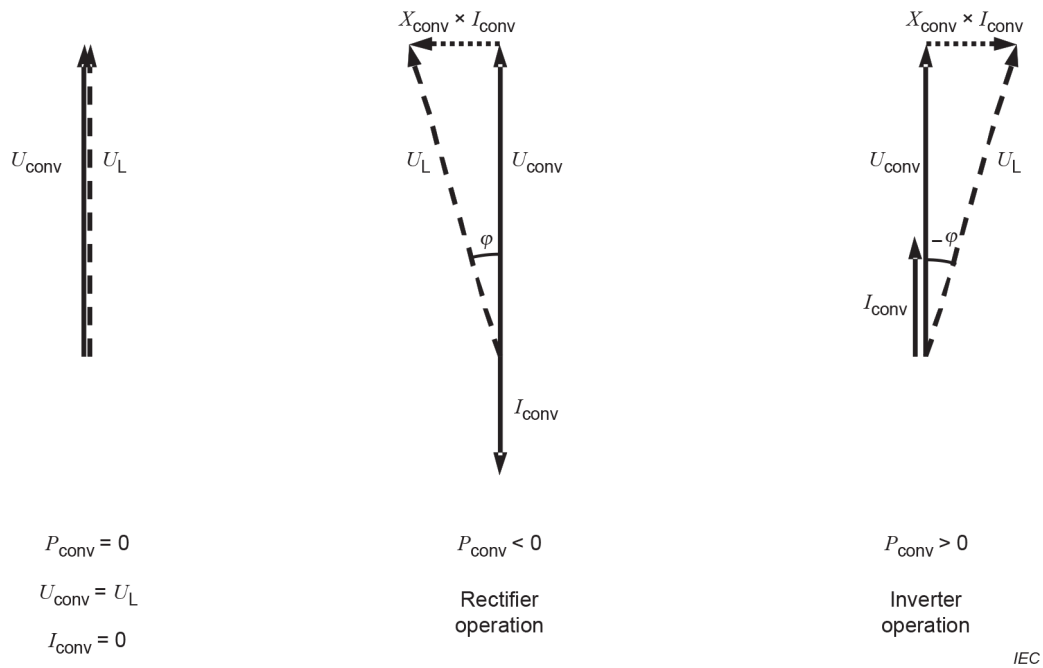

Figure 3 – Principle of active power control

If the angle of the VSC output voltage leads the AC grid voltage, the VSC will inject active power to the AC grid, i.e., it operates as an inverter. On the DC side, an equivalent current will be drawn from the DC source and the voltage $U_d U_{dc}$ will decrease in accordance with Ohm's law ($U_d U_{dc} = U_s - R_d \cdot I_d$).

If, on the other hand, the VSC output voltage lags the voltage of the AC grid, the VSC will absorb active power from the AC grid, i.e., it operates as a rectifier. On the DC side, an equivalent current will be injected into the DC source and the voltage $U_d U_{dc}$ will increase in accordance with Ohm's law ($U_d U_{dc} = U_s + R_d \cdot I_d$).

If the VSC is connected to a passive load, an AC output current will be drawn from the VSC determined by Ohm's law $I_{conv} = U_{conv}/Z$. Again, an equivalent DC current will be drawn from the source and the voltage $U_d U_{dc}$ on the DC capacitor will drop to a value determined by Ohm's law. No active power can be drawn from the AC side, because it is a passive AC circuit.

4.1.2.3 Principle of reactive power control

When active power $P = 0$ the principle of reactive power control is depicted in Figure 4, where the reactive power through the interface inductance is controlled by regulating the amplitude of the VSC output AC voltage.

If the amplitude of the VSC output voltage U_{conv} is higher than the AC grid voltage U_L , the VSC will inject reactive power in the AC grid, i.e., will operate in the capacitive mode. If the amplitude of the VSC output voltage is lower than the AC grid voltage, the VSC absorbs reactive power from the AC grid, i.e., the inductive operating mode.

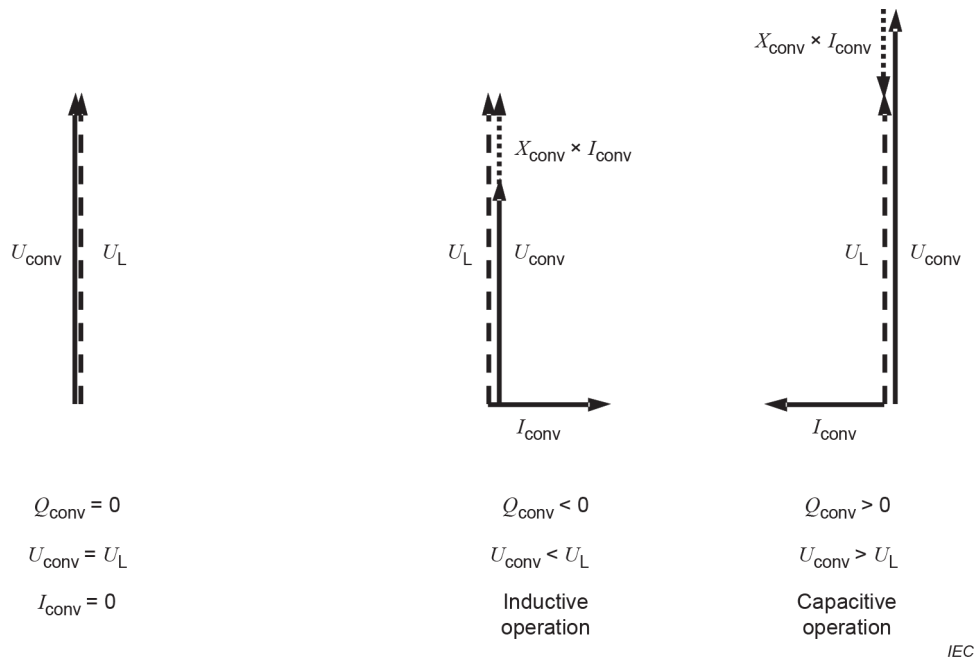

Figure 4 – Principle of reactive power control

4.1.3 Operating principles of a VSC transmission scheme

The point-to-point VSC transmission scheme shown in Figure 5 consists of two VSCs interconnected on the DC side via a DC transmission line and connected to two different AC grids on the AC side. The basic characteristics of a VSC have been described in 4.1.1 and 4.1.2. One of these characteristics is that the DC voltage polarity ~~is always~~ usually remains the same (in contrast with ~~line-commutated converter (LCC) HVDC~~, where the polarity of DC voltage depends on the direction of power transfer). Therefore, the direction of the power flow on the DC line is usually determined by the direction of the DC current. In Figure 5, the current flow and the power flow are from VSC1 (the sending or rectifier end) to VSC2 (the receiving or inverter end) of the DC line.

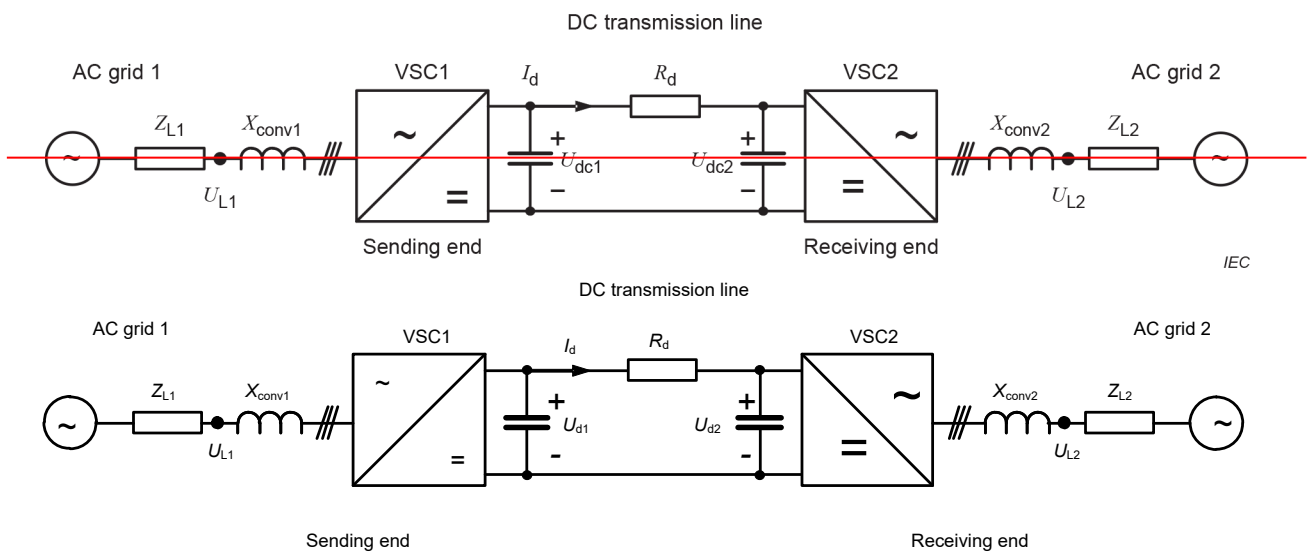

Figure 5 – A point-to-point VSC transmission scheme

The direction of a DC current is always from a higher DC voltage level to a lower DC voltage level. The DC voltage at the sending end of the DC line ~~shall~~ therefore needs to be higher than the DC voltage at the receiving end. The value of the current is determined by Ohm's law,

as the voltage difference between sending and receiving ends divided by the resistance in the DC line $I_d = (U_{d1} - U_{d2})/R_d$.

For example, the DC line power flow can be controlled by holding the DC voltage at the receiving end converter (the inverter) at a constant value, and by letting the sending end converter (the rectifier) control the DC current.

4.1.4 Applications of VSC transmission

In general, the main fields of application of HVDC transmission are interconnection of asynchronous AC systems and long-distance transmission via overhead lines and cables. The following characteristic features of VSC transmission are decisive for different applications.

- The smaller amount of external equipment such as AC harmonic filters results in a compact design of VSC converter stations. Small footprints are beneficial for applications with spatial limitations such as installations in city centres or on remote offshore platforms.
- Since VSC transmission is based on self-commutating operation, applications with isolated and weak AC systems are feasible. During normal operation, the VSC provides voltage and frequency control of the AC system. Operation during AC faults is a major criterion for VSC. The ability of the VSC to inject fault currents facilitates AC system protection and fault clearing. Examples are connection of remote wind farms, oil and gas platforms and remote mines.
- In most cases, VSC transmission operates with a fixed DC voltage polarity. A reversal of direction of power flow requires the reversal of DC current. In case of parallel interconnection of AC systems via AC and DC lines, fast power reversals via DC current control provide an accurate measure for load flow stabilization between the AC systems. Since the polarity of DC voltage does not reverse, multi-terminal systems and HVDC grids are easier to realize with VSC than with LCC HVDC.

4.2 Design life

The selection of VSC transmission as an alternative to LCC HVDC, AC transmission, or local generation is normally motivated by financial, technical or environmental advantages. When evaluating different technologies, it is important to compare their life cycle costs.

The technical design life of transmission systems is normally very long – 30 years or more. An investment, however, ~~should~~ needs only to last as long as it can provide the highest capital value, and this is designated the "optimal life". The optimal life will always be equal to or less than the technical design life.

4.3 VSC transmission configurations

4.3.1 General

With VSC transmission, there are several possibilities for the DC circuit and converter units.

Each VSC substation ~~may~~ can be constructed from a single converter unit ~~of a phase unit topology~~, resulting in a monopolar transmission scheme.

In some applications, it ~~may~~ can be necessary or advantageous to combine several converter units each constructed using the same converter phase unit topology. For example, it ~~may~~ might not be technically feasible or economically optimal to achieve the power, voltage or current rating with a single converter unit. Several converter units ~~may~~ can be combined to achieve increased availability and limited power outage upon faults.

The combination of two or more converter units can be accomplished in a number of ways. The DC terminals of the converter units can be connected in parallel to achieve high output currents or in series to achieve high output voltages.

4.3.2 DC circuit configurations

Both cables and overhead transmission lines can be used for VSC transmission. However, there are several aspects associated with the basic principle of VSC transmission that ~~may~~ can influence the choice.

- Since a VSC generally allows only one DC voltage polarity, the cable does not need to be designed for voltage polarity reversal. This allows the use of extruded cross-linked polyethylene (XLPE) DC cables. Faults on DC cables are considered as exceptional scenarios which result in a permanent fault of the affected section and an interruption of power transfer.
- Since overhead transmission lines are always exposed to lightning strikes and pollution, faults along them are likely. Most line outages are temporary and transmission recommences once the fault is cleared and the air insulation is restored.

A back-to-back configuration is a special case of VSC transmission where the DC transmission distance is zero.

4.3.3 Monopole configuration

4.3.3.1 General

The VSC converter can be operated in different monopolar configurations:

- symmetrical monopole;
- asymmetric monopole with metallic return;
- asymmetric monopole with earth return.

4.3.3.2 Symmetrical monopole

In a symmetrical monopole, the DC output voltages are of equal magnitude but opposite ~~magnitude~~ polarity. The ~~midpoint~~ neutral point t of the DC circuit is earthed, either by capacitors as shown in Figure 6 or by other means, for example a high-frequency earthing reactor on the AC side.

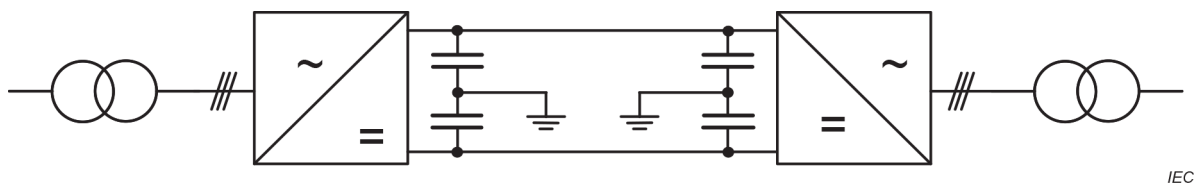

Figure 6 – VSC transmission with a symmetrical monopole

4.3.3.3 Asymmetrical monopole

In an asymmetrical monopole as shown on Figure 7 and Figure 8, the DC side output from the converter is asymmetrical with one side typically connected to earth. It is possible to operate the transmission system in metallic return or in earth return.

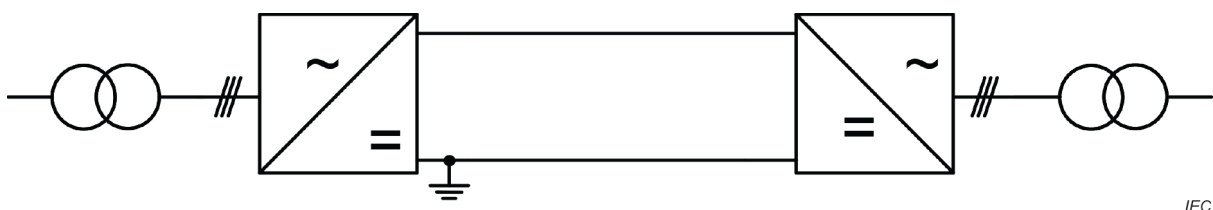

Figure 7 – VSC transmission with an asymmetrical monopole with metallic return



Figure 8 – VSC transmission with an asymmetrical monopole with earth return

4.3.4 Bipolar configuration

Two asymmetrical converters can be connected together in a bipolar configuration either with earth return (Figure 9) or dedicated metallic return (Figure 10).

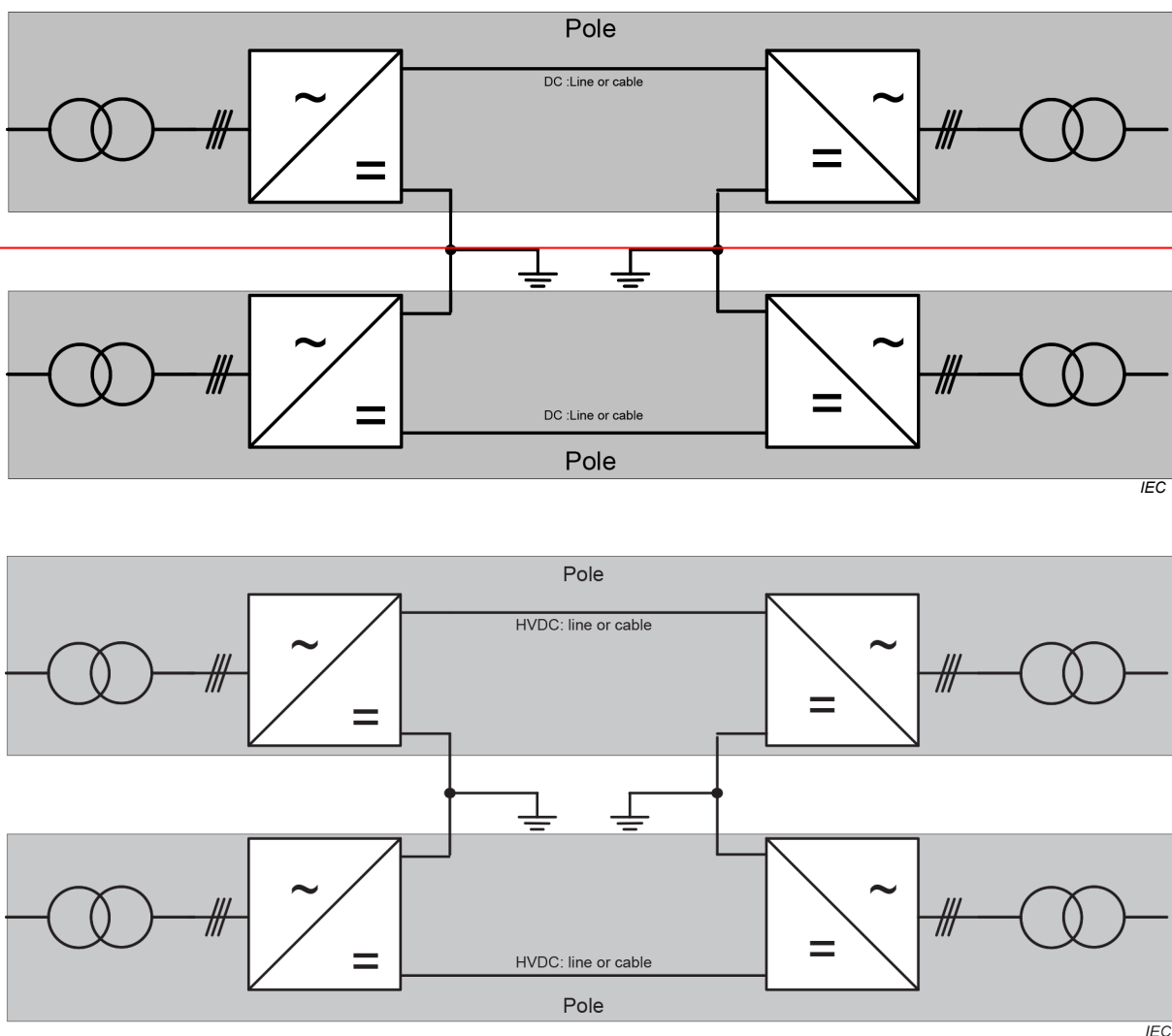

Figure 9 – VSC transmission in bipolar configuration with earth return

The neutral return bus can be designed by a similar process to that which is normally used for bipolar LCC HVDC schemes.

When there is an outage of a converter or DC line/cable, there is normally designed a possibility to operate the remaining system in asymmetrical monopole operation.

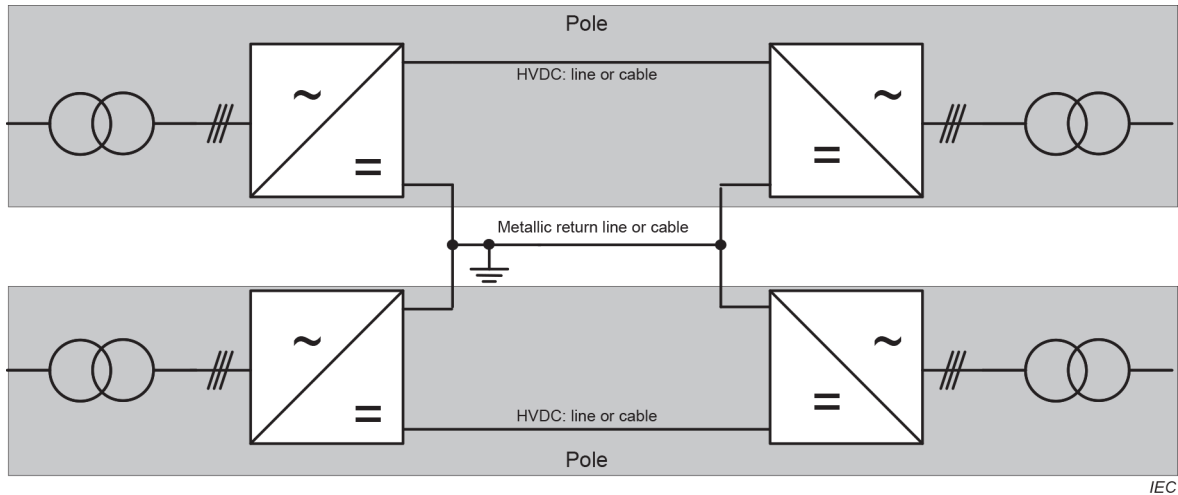

Figure 10 – VSC transmission in bipolar configuration with dedicated metallic return

A variant of the bipolar configuration, known as the rigid bipolar configuration (Figure 11), is also possible. In the rigid bipolar configuration, there is no neutral connection between the two converter stations. Bypass switchgear is provided in parallel with each converter unit such that, in the event of a fault in one converter unit, the system can still be operated with the remaining pole, using the pole conductor of the faulted pole as the neutral return. With the rigid bipolar configuration, power transmission on both poles is interrupted for a short time, while the bypass switchgear is operated, before resuming on the healthy pole.

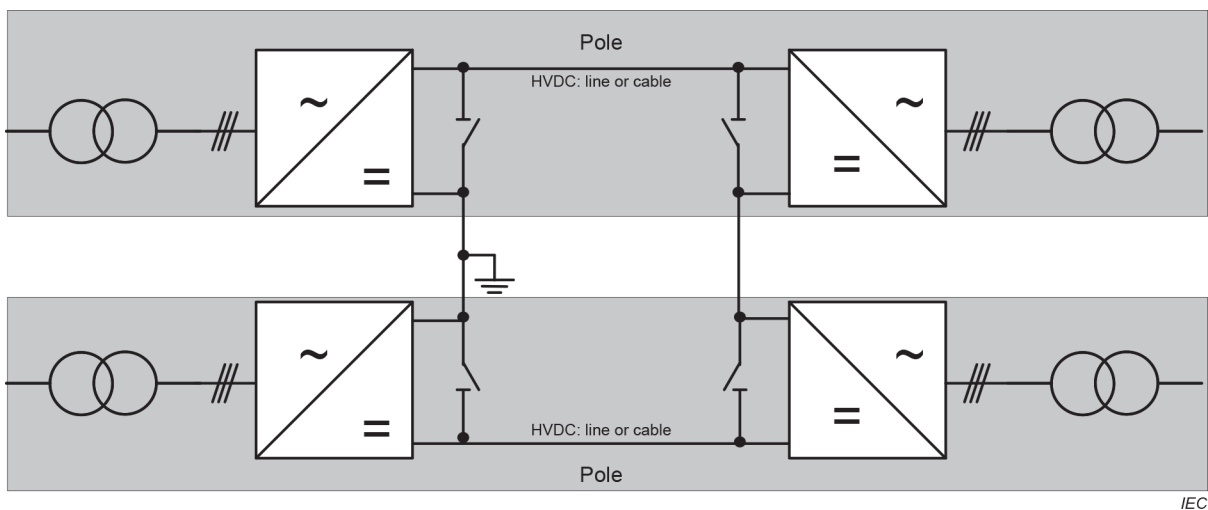

Figure 11 – VSC transmission in rigid bipolar configuration

4.3.5 Parallel connection of two converters

The DC terminals of two VSC converters can be connected in parallel resulting in high DC currents (Figure 12).

To prevent undesirable interaction between the two parallel-connected converters, some level of impedance ~~shall~~ could be provided between the two converters.

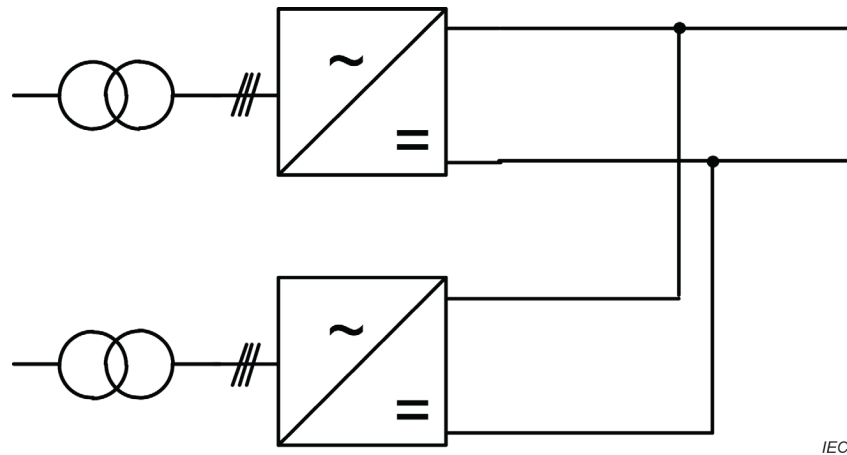

Figure 12 – Parallel connection of two converter units

Where parallel connection of converter units is chosen, a high level control is required in order to coordinate current orders between the converter units.

In order to achieve high reliability upon internal converter unit faults, additional switching and/or breaking devices are required to isolate a faulty converter unit. Obviously, the common DC transmission circuit has no redundancy upon DC line faults.

4.3.6 Series connection of two converters

Two VSC converters can be connected in series on their DC side. This approach can be used to extend the DC voltage capabilities of a VSC transmission relative to the capability of the individual converter units.

The technically most relevant scenario of series connection is the bipolar arrangement outlined in 4.3.4.

4.3.7 Parallel and series connection of more than two converters

In principle, it is also possible to connect more than two converter units in parallel or in series. Connections of each converter unit are either to separate windings of a common transformer or to separate transformers.

In general, the increased complexity of multi converter units ~~has~~ needs to be evaluated with regard to project specific requirements.

4.4 Semiconductors for VSC transmission

In normal operation of voltage sourced converters, the power semiconductors are exposed to a unipolar voltage and ~~have~~ need to be able to conduct the current in both directions. Therefore, power semiconductor switches with turn-on and turn-off capability and with a high voltage blocking capability (typically several kV) in the forward direction are needed.

Today, these requirements are usually achieved by a parallel connection of a turn-off semiconductor device and a so-called free-wheeling diode as shown in Figure 13. However, one variant of the IGBT, the bi-mode insulated gate transistor (BiGT), allows bidirectional conduction of current in the same silicon wafer and therefore does not need a separate free-wheeling diode.

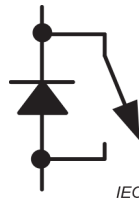

Figure 13 – Symbol of a turn-off semiconductor device and associated free-wheeling diode

Various different turn-off semiconductor devices are suitable for VSC technology, but only IGBTs (insulated gate bipolar transistor, as shown in Figure 14) and variants of the IGBT such as the BiGT and the injection enhanced gate transistor (IEGT) are used in commercial VSC-HVDC projects that have been built to date. Therefore the description of turn-off semiconductor devices in this document is concentrated on IGBTs, although other semiconductors such as GTOs and IGCTs are also usable.

NOTE Semiconductor devices suitable for VSC transmission type are divided into two categories: the "transistor" type, which includes IGBTs, and the "thyristor" type, which includes GTOs and IGCTs. Devices of the "thyristor" type can handle larger powers ~~more efficiently~~ than devices of the "transistor" type, but lack certain control features such as the ability to control the device smoothly between the off and on states using active gate control. Devices of the "thyristor" type also have higher gate power consumption than devices of the "transistor" type, which makes their use in high voltage applications such as VSC transmission more difficult for the time being. Study of the application of devices of the "thyristor" type, such as IGCTs, is still going on.

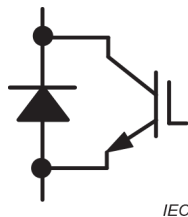

Figure 14 – Symbol of an IGBT and associated free-wheeling diode

Like all diodes, the free-wheeling diodes, which are connected in parallel to the controllable switch, have a significant reverse recovery current when they turn off. Both the IGBTs as well as the free-wheeling diodes ~~have~~ need to cope with these switching transients, particularly current gradients and voltage gradients.

An IGBT is a voltage controlled device; only capacitive currents can flow in the gate terminal. The device can be controlled at any instant, even during the switching transients, i.e. the load current can be influenced by the gate voltage.

IGBTs are short-circuit proof within defined operating conditions. This means that in case of a short circuit, the IGBT limits the load current to several kiloamperes (a process usually known as de-saturation). Within some microseconds, an appropriate gate turn-off signal ~~has~~ needs to be applied to turn off the fault current and not to thermally overstress the device.

Switching times of IGBTs are in the range of microseconds or less. Furthermore, the switching slopes can be adjusted by the gate drive circuit, achieving the optimal waveforms concerning over-voltage peaks and switching losses. Snubbers to keep the rates of rise of current and voltages to acceptable limits are not necessary in many cases. The gate drivers for IGBTs can be simple, since they ~~have~~ need to deliver only a few watts of control power to the gate.

High power IGBTs are made up by a parallel connection of chips to achieve the required current capability. The chips are mounted in press packs or module housings. In most cases, the FWD chips are included in the same housing.

Press pack housings are intended to be clamped between heat sinks; the paths for current and heat are the copper poles of collector and emitter of the devices that are separated by a ring of insulating material. For high voltage devices, this material is high strength porcelain in most cases, though glass fibre reinforced resin is also used.

Module IGBTs are designed for single sided cooling and are mounted on heat sinks by screws; spring loaded clamping is not necessary. The electrical terminals are on the top side of the module; the heat flows through the base plate of the module to the heat sink. Since the electrical part of the module is insulated to the base plate, it is possible to mount modules with different voltage potentials on a shared heat sink.

5 VSC transmission converter topologies

5.1 General

For a high power VSC transmission system, the key issue that determines the cost and operating losses of the overall system is the power circuit structure to construct the AC output voltage waveform. The output voltage waveform ~~should~~ needs to approximate a sine-wave in order to eliminate or minimize the need for harmonic filtering. The switching converter considered for practical implementation is a voltage sourced converter operated with a fixed DC voltage. The converter is a combination of turn-off semiconductor devices that connect the DC input voltage periodically to the output for some intervals to produce the AC output voltage. The converters at each end of a VSC transmission system can be arranged in a number of different ways, with the configuration of the converter normally being referred to as its topology. At the time of writing, two different converter types have been used for commercial projects: those in which the converter valves act as controllable switches and those in which the converter valves act as controllable voltage sources. These two types are described in 5.2 and 5.3 respectively.

Some other converter topologies which share the characteristics of both the controllable switch and controllable voltage source types have been described in the literature [1]¹. ~~The reader is referred to CIGRÉ Technical Brochure No. 492 “Voltage Source Converter (VSC) HVDC for Power Transmission — Economic Aspects and Comparison with other AC and DC Technologies”, for details.~~

It is a fundamental criterion for any viable topology that it enables the functional requirements to be met. Different topologies have different technical characteristics, and therefore allow the overall scheme to be optimized in different ways. Manufacturers ~~may~~ can have different preferred topologies and be able to best optimize their proposals around this preferred topology. It is recommended that customers do not stipulate the topology to be used for a VSC transmission system, unless there are compelling reasons for doing so.

It is possible to arrange the converters to have a single-, three- or multi-phase AC output/input. For the purpose of this document, only the three-phase arrangement will be discussed.

5.2 Converter topologies with VSC valves of switch type

5.2.1 General

The converter switches (normally called VSC valves) perform the function of connecting the AC bus to the DC terminals. If the connection is direct through two alternately operating switches, the AC bus voltage will change between the voltage levels at the two DC terminals. Such a converter is known as a 2-level converter. In the 2-level converter, each of the VSC valves ~~has~~ needs to withstand the voltage between the two DC terminals.

¹ Numbers in square brackets refer to the Bibliography.

If the DC capacitor is subdivided, or additional DC capacitors are added, it is possible to arrange for the AC voltage to move not only to the voltage at **one** of the two DC terminals but also to intermediate levels. The number of voltage levels to which the AC bus voltage can be switched will depend on the number of valves and the number of DC capacitor subdivisions or additional DC capacitors. These arrangements are known as 3-level or multi-level converters, depending on the number of voltage levels that can be achieved. The term multilevel refers to a converter phase unit topology where the AC bus can be switched to attain more than three different voltage levels.

In 3-level or multi-level topologies, the VSC valves do not normally ~~have~~ **need** to be designed for the full DC terminal-to-terminal voltage. For example, in normal operation, each valve in a 3-level converter topology experiences only 50 % of the terminal-to-terminal DC voltage. Similarly, in normal operation, each VSC valve in an n -level topology experiences only the terminal-to-terminal DC voltage of the phase unit divided by $(n - 1)$.

In 5.2.3 and 5.3, converter topologies suitable for VSC transmission systems will be described in more detail. It ~~should be~~ **is** noted that a considerable research and development effort is being invested in voltage sourced converter technology, so additional suitable topologies will likely become available subsequent to the issue of this document.

5.2.2 Operating principle

The basic operating mechanism of an ideal VSC is covered in 5.2.2. The description is initially limited to a 2-level VSC. The 2-level VSC is the simplest structure needed to convert a DC voltage into AC voltages. Although other types of multi-level VSCs are more complex, their basic operating principle does not differ from that of the 2-level VSC.

For the purpose of illustration, the VSC valves are described as ideal switches without any switching losses. A VSC valve in a real application consists of a large number of series-connected semiconductor devices, and is described in greater detail in 5.4. The stray inductances are neglected here, and the DC capacitors have been assumed to have infinite capacitance – i.e., no DC voltage ripple is shown.

As explained in 4.1, the output of the VSC needs to be connected in series with a phase reactor. The phase reactor enables the VSC to control power flow in addition to smoothing the output current.

5.2.3 Topologies

5.2.3.1 Two-level converters

A 2-level converter is the simplest switching arrangement capable of producing AC output from a DC source in the form of a simple square-wave. A three-phase converter using three 2-level phase units is illustrated in Figure 15.

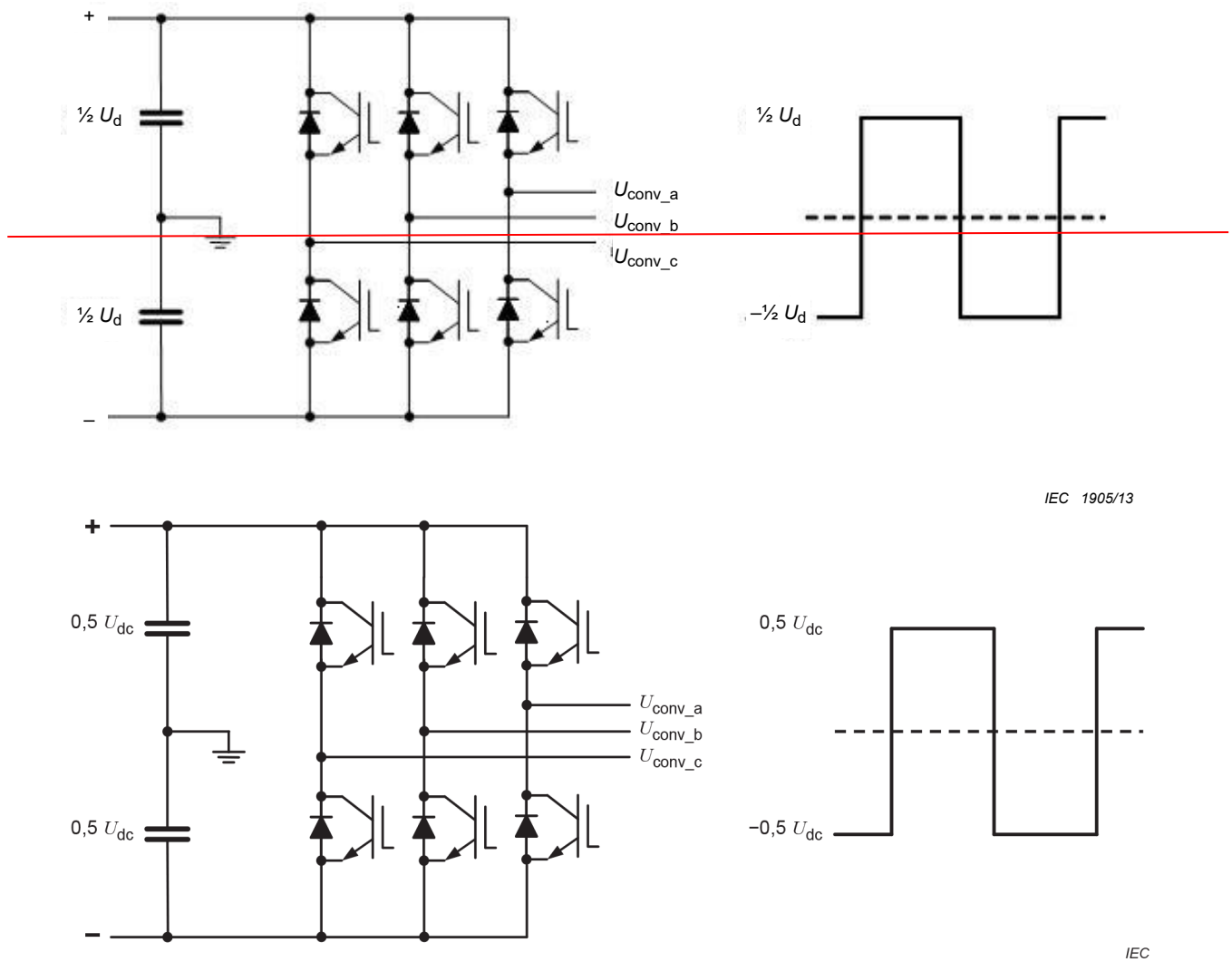

Figure 15 – Diagram of a three-phase 2-level converter and associated AC waveform for one phase

The AC waveform shown in Figure 15 is the phase-to-neutral voltage. The neutral voltage is the average voltage **at the midpoint of the d.c. capacitor** of the converter's two DC terminals.

Since the square-wave output voltage shown in Figure 15 is not acceptable in a practical HVDC scheme, this converter type is normally operated with pulse width modulation (PWM) as described in 9.3.

A typical PWM-switched waveform, using a carrier-based control method with a switching frequency of 21 times the fundamental frequency, is given in Figure 16. For the purpose of this illustration, the DC capacitor has been assumed to have an infinite capacitance (i.e., no DC voltage ripple).

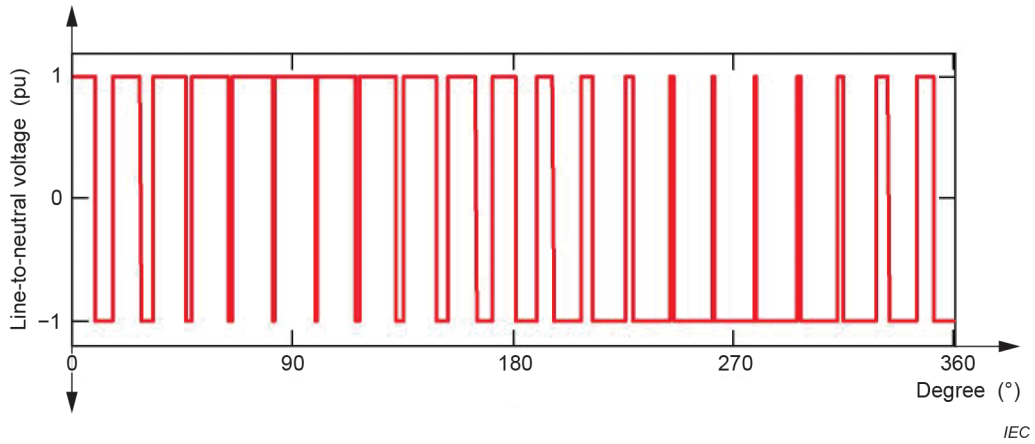
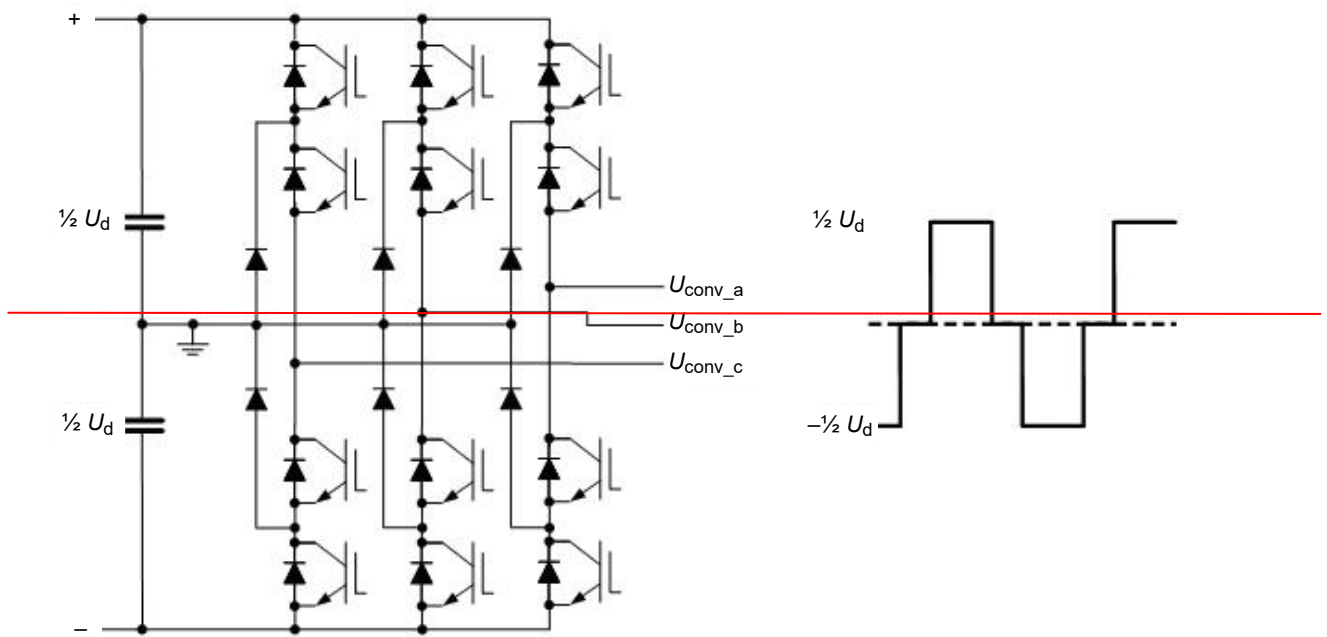

Figure 16 – Single-phase AC output for 2-level converter with PWM switching at 21 times fundamental frequency

Other PWM techniques are also available, such as optimized PWM (OPWM) or selective harmonic elimination method (SHEM). These aim to improve the compromise between power transfer capability, switching frequency and harmonic performance.

5.2.3.2 Three-level neutral-point clamped (NPC) converters

A three-phase converter consisting of three 3-level phase units is illustrated in Figure 17. The converter has three DC terminals to connect to a split or centre-tapped DC source. As seen, there are more valves used than in the 2-level phase unit, and additional diodes or valves are required to connect to the DC supply centre-tap, which is the reference zero potential. However, with identical valve terminal-to-terminal voltage rating, the total DC supply voltage can be doubled so that the output voltage per valve remains the same.



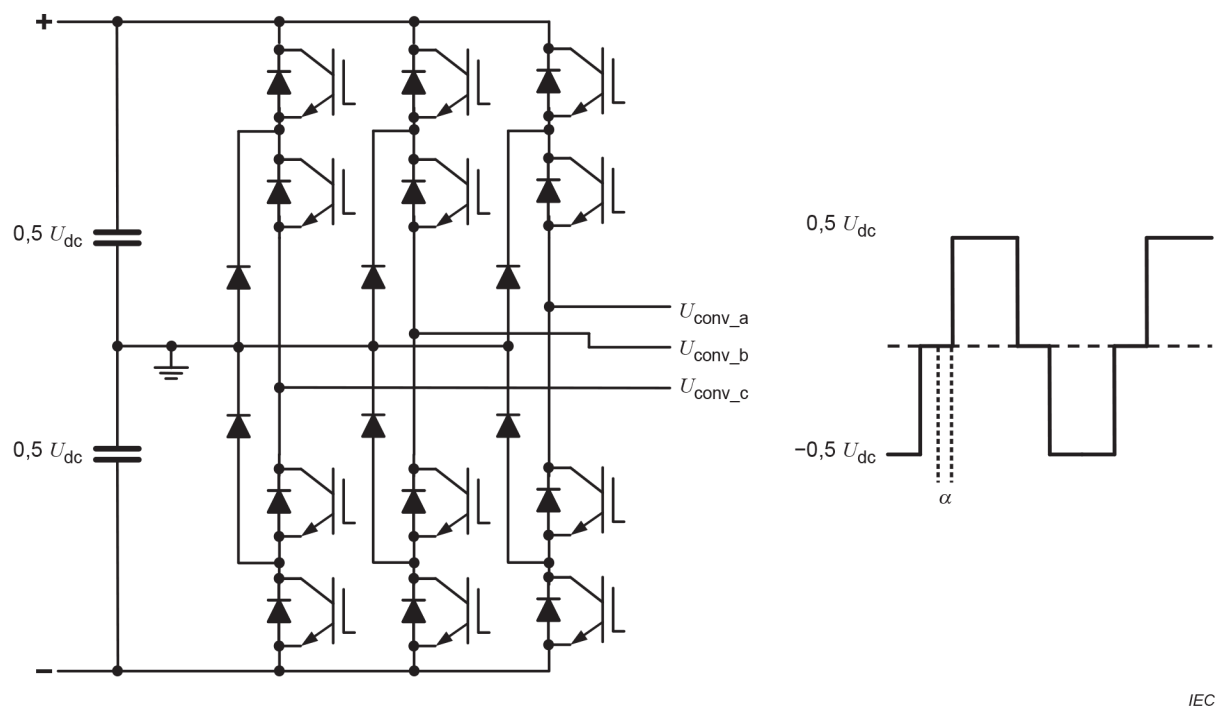

Figure 17 – Diagram of a three-phase 3-level NPC converter and associated AC waveform for one phase

NOTE The neutral-point clamping diodes shown in Figure 17 ~~may~~ can be replaced by IGBTs in some applications.

The AC waveform shown in Figure 17 is the phase-to-neutral voltage. The neutral voltage is the voltage at the midpoint of the DC capacitor. As illustrated in Figure 17, the output voltage of the 3-level phase unit can be positive, negative, or zero. Positive output is produced by gating on both upper valves in the phase unit, while negative output is produced by gating on both lower valves. Zero output is produced when the two middle valves, connecting the centre tap of the DC supply via the two diodes to the output, are gated on. At zero output, positive current is conducted by the upper-middle controllable device and the upper centre-tap diode, and negative current by the lower-middle controllable device and the lower centre-tap diode.

As indicated in Figure 17, the relative duration of the positive (and negative) output voltage with respect to the duration of the zero output is a function of control parameter α , which defines the conduction interval of the top upper and the bottom lower valves. The magnitude of the fundamental frequency component of the output voltage produced by the phase unit is a function of parameter α . When α equals zero degrees, it is maximum, while at α equals 90°, it is zero. Thus, one advantage of the 3-level phase unit is that it has an internal capability to control the magnitude of the output voltage without changing the number of valve switching events per cycle.

The operating advantages of the 3-level phase unit can only be fully realized with some increase in circuit complexity, as well as more rigorous requirements for managing the proper operation of the converter circuit.

An additional requirement is to accommodate the increased AC ripple current with a generally high triplen harmonic content flowing through the mid-point of the DC supply. This ~~may~~ can necessitate the use of a larger DC storage capacitor or the employment of other means to minimize the fluctuation of the mid-point voltage. However, once these problems are solved, the 3-level phase unit provides a useful building block to structure high power converters, particularly when rapid AC voltage control is needed.

In common with the two-level converter, this converter is normally operated with PWM. A typical PWM switched waveform, using a carrier-based control method with a frequency of 21

times fundamental frequency, is given in Figure 18. For the purpose of this illustration, the DC capacitor has been assumed to have an infinite capacitance (i.e., no DC voltage ripple).

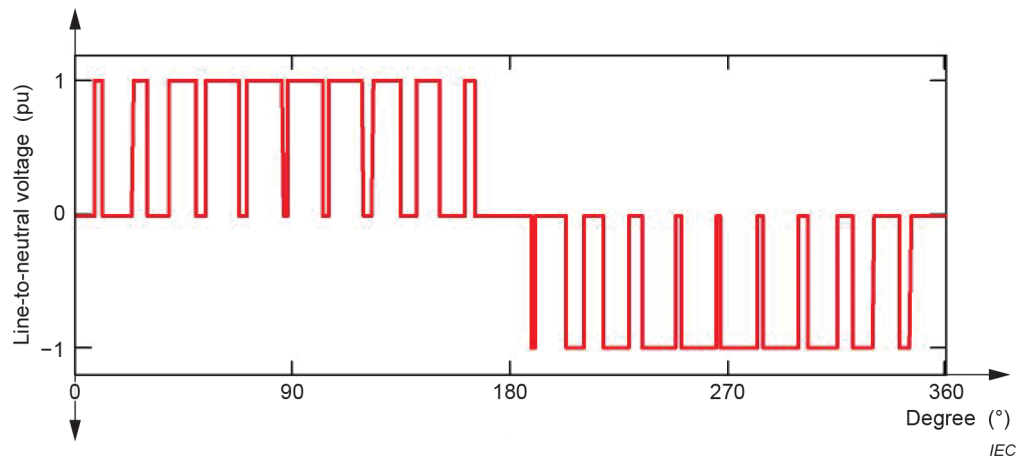

Figure 18 – Single-phase AC output for 3-level NPC converter with PWM switching at 21 times fundamental frequency

5.2.3.3 Other multi-level converter topologies

The neutral-point clamped circuit can be extended to higher numbers of output levels, for example 5 levels, but at the expense of disproportionately greater complexity. Another converter type which has been used in some power electronic applications is the "flying capacitor" or "floating capacitor" circuit, which can also exist in 3-level and 5-level forms but suffers the same disproportionately greater complexity as the number of output levels is increased. These and other possible multi-level converter topologies are described in [2], [3].

5.3 Converter topologies with VSC valves of the controllable voltage source type

5.3.1 General

With valves of the controllable voltage source type, each VSC level is effectively a single-phase VSC in its own right, and contains power semiconductors and a capacitor for energy storage. Each level has two main terminals used for the series connection of the VSC levels within the valve. By appropriate control of the IGBTs within the valve level, either the voltage of the capacitor or zero volts can be applied to the main terminals of the VSC level.

By individual and appropriate control of the VSC valve levels, a desired voltage can be generated at the valve terminals. The valve voltage is the sum of ~~those~~ the capacitor voltages, of the submodules that are in the active state (i.e. in which the capacitor voltage is applied to the main terminals of the VSC level). The VSC valve submodules or cells are controlled such that the sum of the voltages of the upper arm and lower arm of one phase unit equals to the DC voltage whereas the instantaneous voltage on the AC terminals is determined by the ~~ratio~~ of difference between the voltages of the two converter phase arms of one phase unit.

Assuming infinite storage capacitances with equal voltages in the individual ~~valve levels~~ MMC building blocks, $n + 1$ different voltage steps can be applied to the terminals of a valve consisting of n valve levels. Assuming a high number of VSC levels per valve, the topology can be approximated by electrical equivalent as shown in Figure 19. Each valve can be considered as a controllable voltage source.

The valve reactors contribute to both the phase reactance and the DC reactance, and are essential for the current control within the phase units. Furthermore, they also limit the peak current and current gradients in case of severe faults, such as short circuit between the DC terminals.

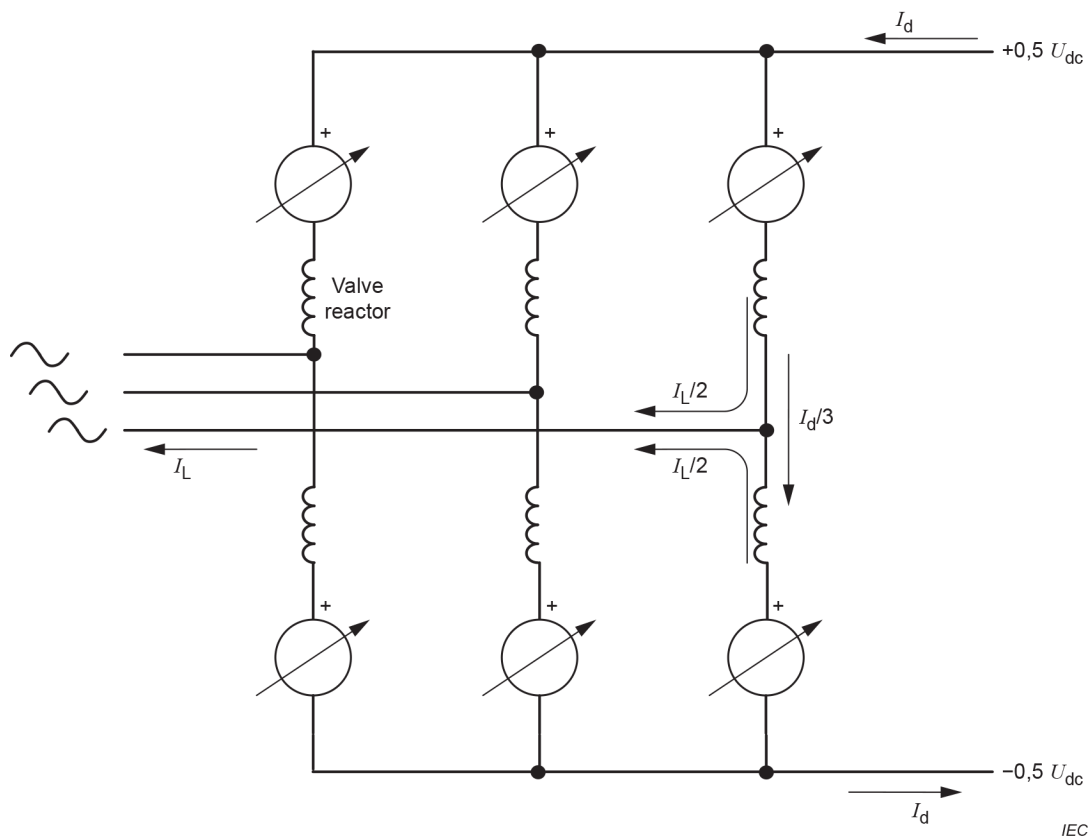
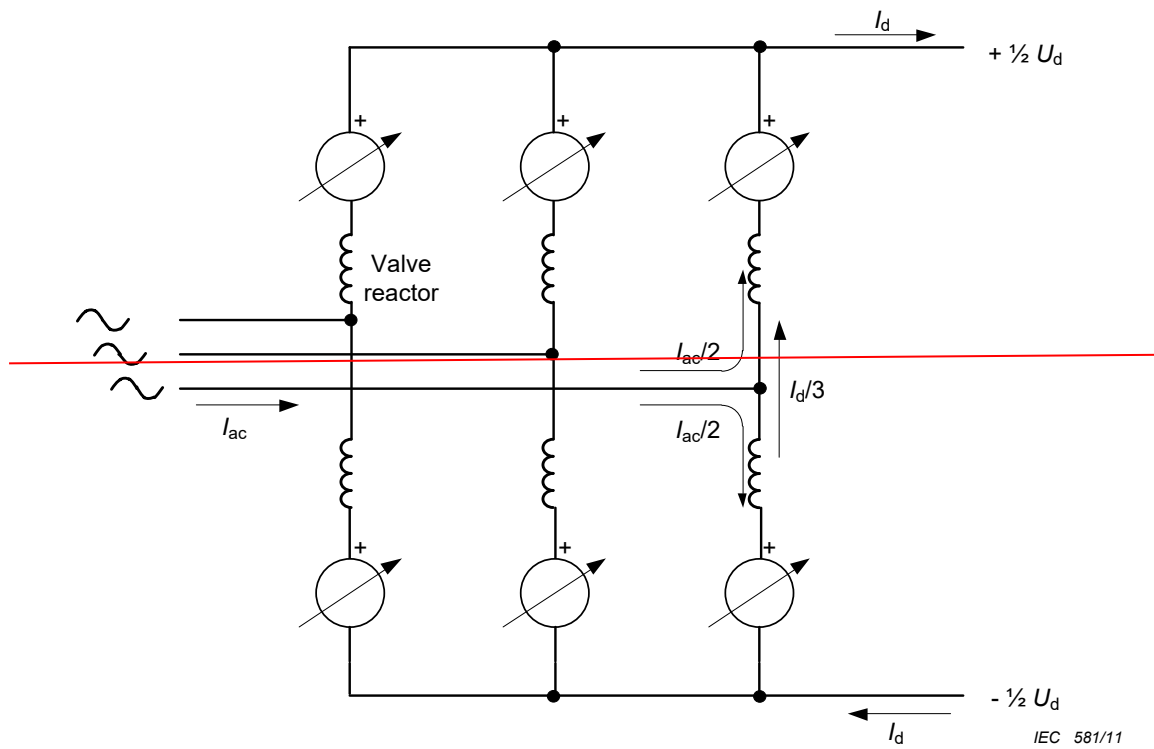

Figure 19 – Electrical equivalent for a converter with VSC valves acting like a controllable voltage source

Because of its modular design and the multi-level technology, it is referred to as modular multi-level converter (MMC) topology. For the design of the individual VSC levels, different

power building blocks can be used. At the time of writing, ~~two~~ three different topologies are used:

- MMC with VSC levels in half-bridge topology;
- MMC with VSC levels in full-bridge topology;
- MMC with VSC levels in a mixture of half-bridge and full-bridge topologies.

Since the circuit is inherently modular, it is relatively straightforward to obtain high numbers of output levels, without requiring either PWM or series-connected IGBTs. Thus, AC filters can be omitted in many cases and considerations of voltage distribution amongst series-connected IGBTs do not arise.

This type of converter can also be realized with multiple IGBTs connected in series in each controllable switch, giving an output voltage waveform with fewer, larger, steps than the MMC. This configuration is referred to as the cascaded two-level (CTL) converter but is functionally identical to the MMC in every aspect apart from the harmonic performance which ~~may~~ can be slightly poorer.

5.3.2 MMC topology with VSC levels in half-bridge topology

Each of the 6 variable voltage sources shown in Figure 19 is realized with a series connection of identical VSC valve levels with an electrical equivalent as shown in Figure 20. The VSC valve level is a two-terminal component with its own DC storage capacitor unit as shown in Figure 20. These VSC valve levels are individually controlled and can be switched between a state with full submodule voltage (voltage of the associated storage capacitor) and a state with zero submodule voltage for both current directions. If the submodule voltage is applied to the VSC valve level terminals, the capacitor can be charged and discharged dependent on the current direction of the converter ~~phase~~ arm.

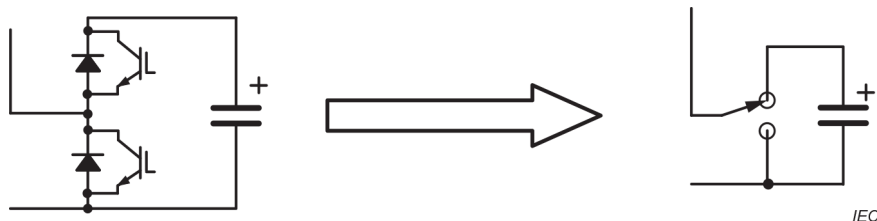
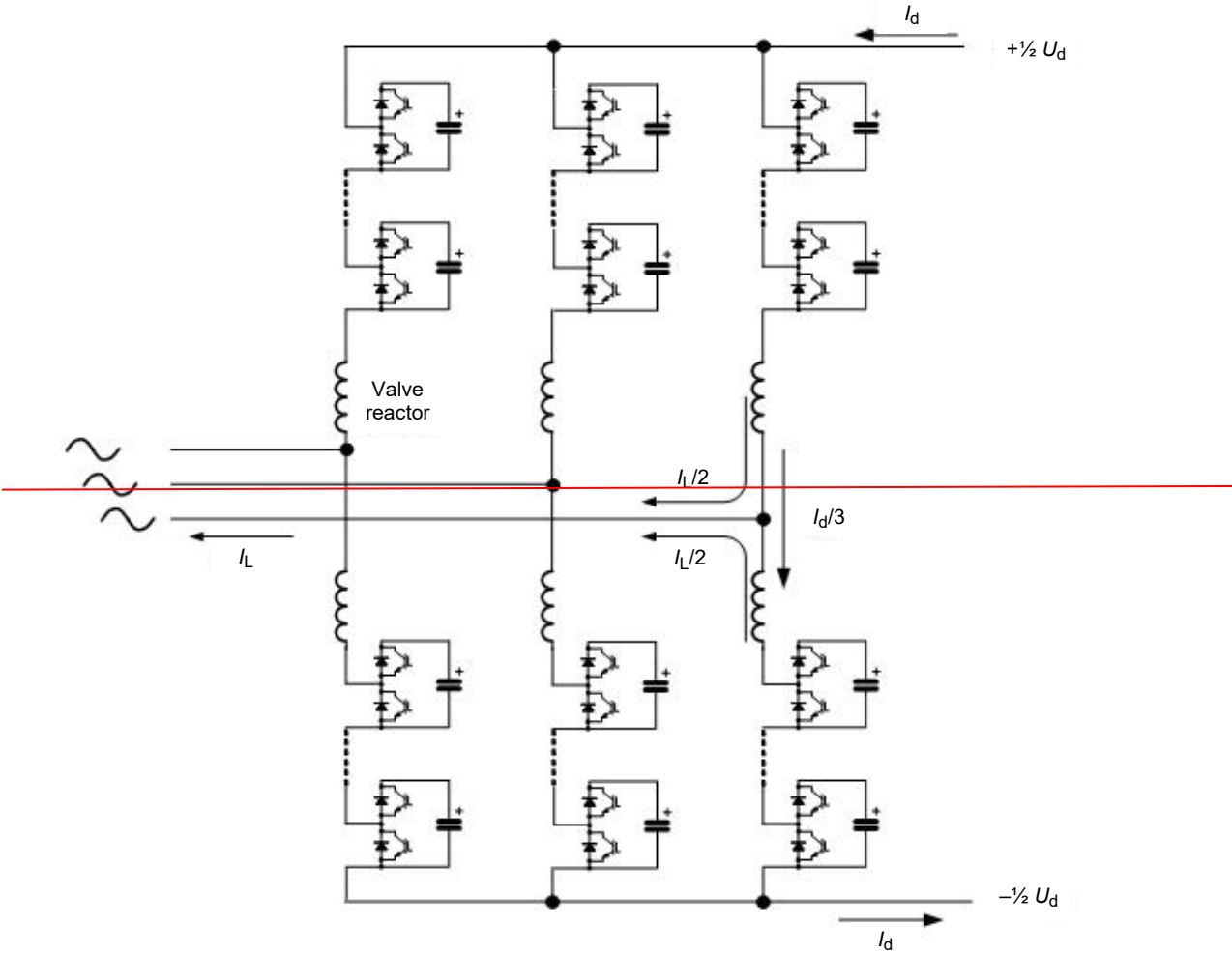

Figure 20 – VSC valve level arrangement and equivalent circuit in MMC topology in half-bridge topology

The typical electrical arrangement of VSC valve levels and valve reactors in a converter block is shown in Figure 21.

NOTE The valve reactors can be located on either the AC or DC side of the valves.

The VSC valve levels are controlled in that way that the sum of the upper arm and lower arm of one phase unit equals to the DC voltage whereas the instantaneous voltage on the AC terminals is determined by the ~~ratio~~ difference of the voltages of the two converter ~~phase~~ arms of one phase unit.



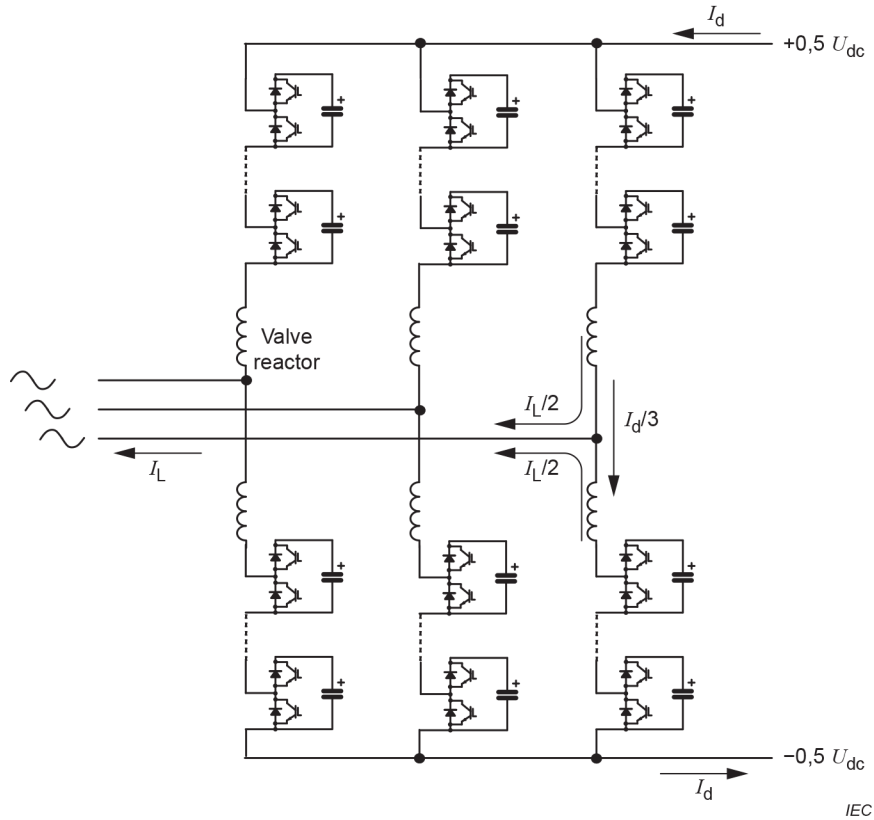

Figure 21 – Converter block arrangement with MMC topology in half-bridge topology

5.3.3 MMC topology with VSC levels in full-bridge topology

The MMC topology with "full-bridge" VSC levels operates on very similar principles to that based on half-bridge VSC levels. The principal difference is that each VSC level consists of one storage capacitor and four IGBTs in a bridge configuration as shown in Figure 22.

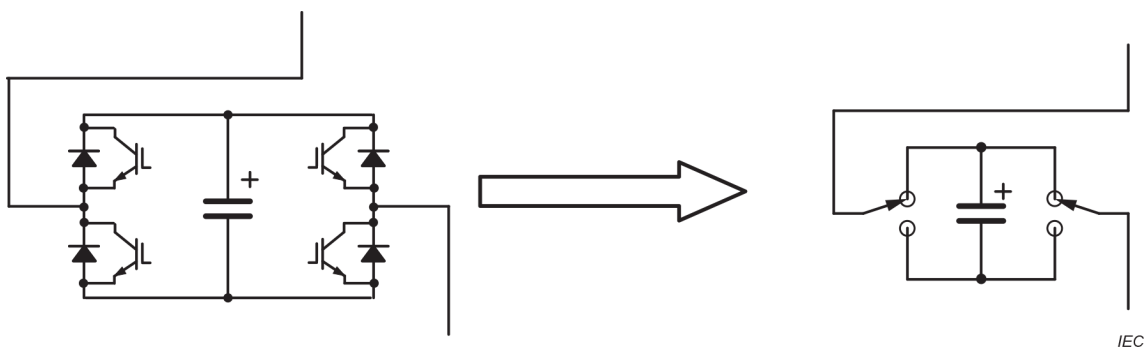

Figure 22 – VSC valve level arrangement and equivalent circuit in MMC topology with full-bridge topology

In common with the half-bridge submodule configuration, each VSC level in the full-bridge configuration is capable of producing an output voltage of zero or a positive output voltage equal to the capacitor voltage. However, it can alternatively produce a negative output voltage equal to the capacitor voltage.

In contrast to the converter arrangements outlined in 5.2 and 5.3.2, this converter arrangement is capable of producing a DC output voltage of either polarity, a feature which can be beneficial in applications where a VSC transmission station is connected as a tap onto

an existing line commutated HVDC link or when the HVDC scheme uses a line commutated rectifier and a voltage sourced inverter.

A second advantage of the full-bridge circuit is that it permits faults on the DC side of the converter to be cleared by using only the power semiconductors in the valve, without requiring any additional switchgear.

On the other hand, the full-bridge circuit requires, in principle, twice the number of IGBTs compared with the half-bridge circuit.

5.3.4 CTL topology with VSC cells in half-bridge topology

Each of the 6 variable voltage sources shown in Figure 19 is realized with a series connection of identical VSC valve cells. One VSC valve cell acts as a single-phase two-level converter and functions electrically equivalent to one level of the MMC described in 5.3.2, except that the voltage rating is higher. Instead of a single IGBT-diode ~~level~~ pair in ~~one MMC level~~ each switch position, multiple IGBT-diode ~~levels~~ pairs are connected in series and synchronously controlled as one switch in one CTL cell.

The typical electrical arrangement of VSC valve cells and valve reactors in a converter block is similar to Figure 21. The ~~IGBT/diode levels~~ MMC building blocks depicted in Figure 21 are substituted by valve cells in CTL topology.

The cell DC capacitor voltage in the CTL topology corresponds to one valve voltage step.

5.3.5 CTL topology with VSC cells in full-bridge topology

The CTL topology with "full-bridge" VSC cells functions similarly, in principle, to the MMC topology with VSC levels in full-bridge topology, in 5.3.3. The main difference between CTL topology with VSC cells in full-bridge topology and MMC topology with VSC levels in full-bridge topology is the number of IGBT-diode levels per CTL cell or MMC level. Each CTL cell consists of ~~multiple IGBT/diode levels in series connection and each MMC level is of one IGBT/diode level~~ one IGBT-diode pair in each switch position.

5.4 VSC valve design considerations

5.4.1 Reliability and failure mode

In addition to the number of series-connected valve levels that are needed to sustain the converter voltage rating, each single valve in a VSC transmission scheme ~~shall~~ needs to include a few redundant valve levels. In case of failure of an individual valve level component, uninterrupted operation of the remaining healthy valve levels is mandatory. Therefore, a faulty valve level ~~shall~~ needs to safely and controllably enter into a short-circuit mode and be capable of conducting current until it can be changed out, for example during a scheduled maintenance period.

This capability of short-circuit failure mode (SCFM) operation is very critical for series-connected valve levels, and ~~shall~~ needs to be verified by appropriate tests under conditions that are relevant for a particular application. Some special designs of presspack IGBT allow SCFM to be assured. Module IGBTs, however, do not exhibit this behaviour and a faulty module IGBT ~~may~~ can result in an open circuit. Thus, additional components in parallel to the valve level terminals are required to ensure SCFM.

The operating voltage of the IGBT ~~shall~~ needs to be selected to be low enough to achieve an adequately low failure-in-time (FIT) rate.

In selecting the operating voltage and current of the IGBT, due consideration ~~should~~ needs to be given to the load cycling requirements for the VSC system.

5.4.2 Current rating

One of the important design bases of the semiconductor in the VSC valve is rated current. In addition, the valve ~~should~~ needs also to be able to handle peak current, including ripple and transients, as well as margins for control and protection actions including converter valve blocking delays and circuit breaker operating time. The rated ~~phase~~ arm current gives the nominal stress on the component and ~~shall~~ needs to be considered regarding power losses and junction temperature on the IGBT.

5.4.3 Transient current and voltage requirements

An important aspect of IGBTs is their capability to turn on and turn off current and voltage. This capability is defined in the switching safe operating area (SSOA) shown in Figure 23. There are several types of SSOA, including the Reverse Bias Safe Operating Area (RBSOA) which defines the turn-off capability of the IGBT and the Reverse Recovery Safe Operating Area (RRSOA) which defines the turn-off capability of the free-wheeling diode.

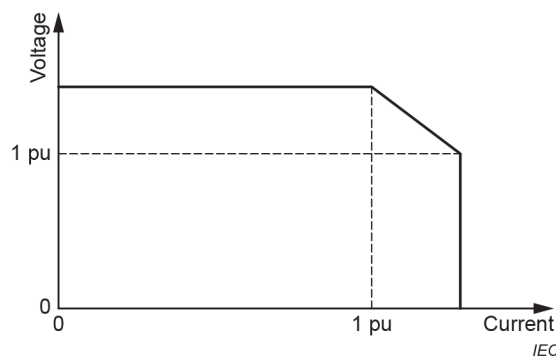

Figure 23 – Typical SSOA for the IGBT

During switching, the IGBT ~~shall be~~ is able to turn off the peak current, including ripple. Additionally, a margin is added to handle current control regulation and protection actions during transient conditions. The valve ~~shall~~ is also ~~be capable of turning~~ able to turn off the current which results from a short circuit occurring close to the valve. The IGBT short-circuit operation capability is defined by the SCSOA (short-circuit safe operating area), which is slightly different from the SSOA under normal operation.

5.4.4 Diode requirements

In many converter topologies (including the 2-level and 3-level converters and the MMC with half-bridge topology), the free-wheeling diodes (FWD) in a VSC bridge act as an uncontrolled rectifier bridge. Thus they can be exposed to severe transient overcurrents, for example during DC-side short circuits or at energization.

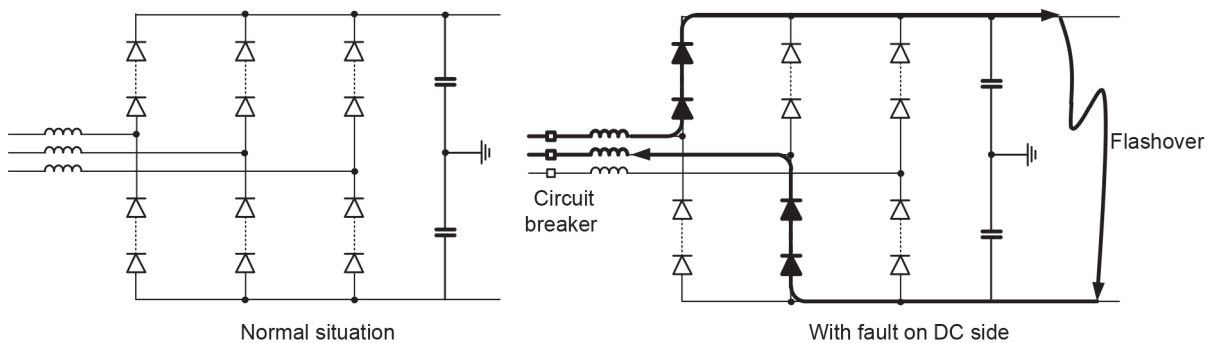

Figure 24 – A 2-level VSC bridge with the IGBTs turned off

In case of a DC side fault, as shown in Figure 24, a short circuit between the two DC terminals creates a fault current path through the diodes. The current in the AC phases in the VSC bridge is limited only by the short-circuit impedance of the AC network and the reactance in the converter, for example the phase or valve reactors and/or transformers. The fault current is detected by the protection system, which will open the breaker on the AC side and thereby eliminate the fault current. A normal protection and breaker scheme takes a time equivalent of three 50/60 Hz fundamental frequency cycles before the fault current is extinguished. If the DC system only consists of cables, a fault will be very unlikely. However, the consequences ~~may~~ might not be acceptable if the system is not designed to handle the fault. The valve ~~should be~~ is designed to handle the fault current with an asymmetrical offset as a worst case. Here, no reapplied voltage occurs since the breaker has disconnected the AC system.

Another transient that the diode ~~may~~ can experience occurs if the VSC is energized through the AC breaker when there is either no voltage, or a low voltage, on the DC side. In this case, the converter experiences a surge inrush current and an overvoltage will occur on the DC bus. The valve ~~shall be~~ is designed to handle the inrush current, or the current will ~~have~~ need to be limited. The normal method for doing this is to include pre-insertion resistors.

5.4.5 Additional design details

Besides controlling the turn-off semiconductor device in regular operation, the gate unit ~~should~~ needs to keep the switching device within the safe operating area in all other operational and short-circuit conditions. IGBTs have proven comparatively easy to handle in this respect, thereby facilitating precise control of switching waveforms. This, in turn, is necessary for achieving proper control and protection strategies for the converter.

The switching transients which appear when the IGBT turns on or off give stress to the IGBT and other components in the valve levels. The energy stored in stray inductances and capacitances will generate transient voltages and currents respectively.

Gate voltage control makes it possible to control the voltage between the main two terminals of the IGBT ~~at its~~ during the turn-on and turn off processes. Suppressing the speed of turn off makes the energy stored in the loop stray inductance dissipate in the IGBT itself. Applying the gate voltage control technology, the snubber circuit can be omitted from the circuit, although switching losses in the IGBT become larger.

For converter topologies with VSC valves of switch type, it is possible to design the VSC valve such that it does not use traditional snubber circuits for protecting the individual IGBTs. In this case, the IGBTs ~~shall~~ themselves maintain sufficient voltage sharing, both during switching and blocked conditions, by means of gate control and DC grading resistors. This, in turn, requires a small spread in device data concerning characteristic switching times, switching transient properties, and leakage currents in the blocked state.

Converter topologies with VSC valves of the controllable voltage source type only require synchronized switching of individual valve levels when multiple IGBTs are connected in series in each switch position (as in the cascaded two-level converter). Where no direct series connection of IGBTs is used, a coordination of IGBTs switching properties of individual valve levels is not required.

5.5 Other converter topologies

The technical field of VSC transmission is developing rapidly. Accordingly, it is to be expected that other converter topologies in addition to those described above will emerge. Some existing known topologies are already described in [3].

Purchasers of VSC transmission schemes ~~should~~ need to consider such alternative converter topologies on their merits and not limit the permitted circuit topologies to those that have been described in 5.2 and 5.3.

5.6 Other equipment for VSC transmission schemes

5.6.1 General

According to its principle of operation, only a few components are essential in a voltage sourced converter (VSC). These are

- a means to convert DC into AC voltages provided by a converter comprising VSC valves and controls;
- an AC side reactance provided by phase reactors/valve reactors, transformers, or a combination thereof;
- a DC voltage source provided by at least one VSC DC capacitor, submodule DC capacitor or cell DC capacitor.

In addition to these key components, a complete VSC substation ~~may~~ can also need

- AC and DC filters,
- surge arresters,
- circuit breakers and switches, and
- measuring equipment.

The above equipment ~~items~~ are not always necessary in all converter topologies, but differ due to the real requirements because different components are stressed differently in the different topologies.

5.6.2 Power components of a VSC transmission scheme

Figure 1 shows the basic structure of a VSC substation and the location of the major power components. Depending on the design concept and the VSC substation topology, several components might occur more than once in a real structure, while others might not be needed. The functions and important design aspects of each component are briefly explained in 5.6.3 to 5.6.11.

5.6.3 VSC substation circuit breaker

The VSC substation circuit breaker is located at the feeder from the AC transmission system to the VSC transmission scheme. Its main function is to connect and disconnect the VSC substation to and from the AC system. There are no special requirements compared to what is common practice for circuit breakers used for AC substation applications.

Depending on the start-up concept of the VSC transmission scheme, a circuit breaker can be equipped with a closing resistor, or a separate resistor, with either a circuit breaker or disconnecter in parallel with it, ~~may~~ can be provided in series with the main circuit breaker. The resistor reduces the charging currents of the DC circuit, resulting in smaller temporary AC system disturbances and lower stresses on the free-wheeling diodes during energization.

5.6.4 AC system side harmonic filters

Depending on the converter design and AC system conditions, filtering ~~may~~ can be required to prevent VSC-generated harmonics from penetrating into the AC system or to prevent amplification of background harmonics on the AC system.

As a side effect, harmonic filters generate fundamental frequency reactive power which needs to be considered in the overall P-Q operating range of the VSC system. The design principles of system side harmonic filters and any associated circuit breakers do not differ from the design practice for HVDC systems with line-commutated converters (LCC) or flexible alternating current transmission systems (FACTS). High pass, single, double or triple tuned filters ~~may~~ can be used as described in IEC TR 62001-1 [4].

5.6.5 Radio frequency interference filters

Radio frequency interference (RFI) filters reduce to acceptable limits the penetration of high frequency (HF) harmonics into the AC system.

HF harmonics generated require special attention during the design of a VSC substation. To calculate line-carried HF harmonics, a detailed representation of the VSC substation layout is necessary, including the structure and geometry of power components, busbars and grounding system. Additionally, the current and voltage waveforms experienced during the conversion process ~~shall~~ need to be known.

The design principles for the RFI filter do not differ from the design practice for LCC HVDC or FACTS.

5.6.6 Interface transformers and phase reactors

In many cases, the VSC substation design will include interface transformers. In general, they can ~~fulfill~~ fulfil the following tasks:

- 1) provide a reactance between the AC system and VSC unit;
- 2) adapt a standard AC system voltage to a value matching the VSC AC output voltage and allow optimal utilization of VSC valve ratings;
- 3) connect several VSC units together on the AC side that have different DC voltage potentials;
- 4) prevent zero sequence currents from flowing between the AC system and VSC unit.

Depending on the design concept applied to the VSC substation, the reactance mentioned under point 1) can be provided by a phase reactor, a transformer, or a combination thereof. The reactance is necessary to allow control of the AC output current of the VSC. Design criteria to determine the size of the reactance are

- the required dynamic behaviour of the system,
- the tolerable harmonic content of the converter AC current, and
- constraints revealed from analysis of transient conditions and fault scenarios.

If points 2) to 4) do not apply under specific circumstances, the required reactance could be provided by phase reactors, which would eliminate the need for a transformer.

For the design of reactors or transformers, the following points ~~have~~ need to be taken into account:

- DC voltage stress on converter winding insulation to ground, for the cases of asymmetrical monopole or bipole;
- stresses due to fundamental current;
- saturation characteristics with respect to possible AC harmonic and DC flux components;
- stresses due to harmonics in the lower and middle frequency range;
- dielectric stresses due to harmonics in the middle and upper frequency range, particularly for VSC valves of the switch type;
- dielectric stresses due to normal operating voltage and transient voltages occurring during fault scenarios.

Particularly in the case of high-voltage VSC valves of the switch type, the magnitudes of the harmonic voltages generated require detailed design studies to provide reliable information about the voltage and current profiles along windings. The interface transformer does not require a tap changer. However, if a tap changer is used, it is possible to optimize the VSC operation, for example to achieve reduced power losses or to increase power capability under low-voltage conditions.

5.6.7 Valve reactor

For valves of the controllable voltage source type, valve reactors are connected in series to the VSC valve levels as shown in Figure 19. These reactors have several different functions:

- the three-phase units represent three DC voltage sources, connected in parallel. During operation, these voltages cannot be exactly equal, resulting in circulating currents between the three-phase units. The valve reactors limit these circulating currents and enable to control them;
- the valve reactors limit the valve short-circuit current;
- the valve reactors are a contribution to the interface impedance between the converter and the AC network;
- in some designs, the valve reactors ~~may~~ can be combined with tuning capacitors and play a role in limiting circulating harmonic currents between phases.

NOTE The valve reactors can be placed in several locations, for example at the DC terminals, at the AC terminals, distributed amongst the valve submodules or integrated into the same tank as the interface transformer.

5.6.8 DC capacitors

5.6.8.1 VSC DC capacitor

5.6.8.1.1 General

The VSC DC capacitor, in conjunction with the DC cable (where used), provides the DC voltage necessary to operate the VSC. It is connected directly in parallel to the DC terminals of the VSC phase units. For the design of the VSC DC capacitor, the following aspects need to be considered.

5.6.8.1.2 Commutation circuit inductance

Switching the semiconductor devices of the VSC causes HF commutation current to flow through the commutation circuit formed by the switching valves, the VSC DC capacitor, and the connecting bus bars. Due to the stray inductance within the commutation circuit, these HF currents result in transient voltage stresses on the switching valves. To minimize these stresses, the inductance of the connection of the VSC DC capacitor to the valves ~~should be~~ usually is as low as possible.

5.6.8.1.3 DC voltage ripple

VSC operation results in harmonic currents flowing in the DC circuit. These harmonic currents cause harmonic voltages (also known as DC voltage ripple). The following factors will influence the size of the DC voltage ripple:

- imbalances in the AC system and/or converter operation;
- pre-existing harmonics in the AC network;
- VSC valve switching strategy.

5.6.8.1.4 Capacitance of the VSC DC capacitor

The VSC DC capacitance ~~shall~~ needs to be large enough to keep the DC voltage ripple within tolerable limits.

5.6.8.1.5 Control aspects

The DC voltage influences active and reactive power exchange with the AC system. To achieve stable operation of the transmission system, it is important to keep the DC voltage within tight limits. Changing power orders, AC system unbalances, or system transients change the operating conditions of the VSC and can cause DC voltage fluctuations or

oscillations. Due to its energy storage capability, the VSC DC capacitor stabilizes the operation of the VSC.

Important design parameters of the VSC DC capacitor are as follows:

- maximum DC voltage for continuous operation;
- maximum acceptable DC voltage variations under transient conditions, such as faults on the AC system.

5.6.8.1.6 Harmonic coupling of different VSC substations connected to one DC circuit

Harmonic currents generated by a VSC cause harmonic voltages not only on their own VSC DC capacitor, but also on the VSC DC capacitors in other VSC substations connected to the same DC circuit. As a result, the different VSC substations in a transmission scheme become mutually coupled via the DC circuit. To avoid unwanted interactions between the VSC substations, this coupling ~~should be~~ is reduced to the largest extent possible. The capacitance of the VSC DC capacitor is an important factor influencing the coupling between the VSC substations.

5.6.8.2 Submodule/cell DC capacitor

5.6.8.2.1 General

In principle, the design and function of the submodule/cell capacitors for the MMC and CTL technologies are similar to that of the VSC DC capacitors.

However, due to their operation principle, the current stresses are different for DC submodule or cell capacitors. The individual submodules or cells can be individually switched off or on depending on output voltage generation. When the submodule is switched off the valve current does not pass through the DC submodule/cell capacitor and the capacitor current is zero. Conversely, when the submodule or cell is switched on, the full valve current flows through the capacitor. In the "on" state, components of DC current and fundamental and low order harmonic currents ~~have need~~ to be considered. The current flow in the "on" state results in a significant ripple voltage of the submodule/cell capacitors per power cycle. The average and RMS capacitor current stresses are calculated based on current contribution in the "on" state.

5.6.8.2.2 Commutation circuit inductance

Similar to the VSC DC capacitor, switching the semiconductor devices of the submodule causes HF commutation current to flow through the commutation circuit of the submodule. Due to the stray inductance within the commutation circuit, these HF currents result in transient voltage stresses on the submodule. To minimize these stresses, the inductance of the submodule ~~should be~~ is as low as possible.

5.6.8.2.3 DC voltage ripple

a) Submodule capacitor voltage ripple

As mentioned before, the ratio of the voltage ripple to DC voltage of the submodule capacitor is larger than that of VSC DC capacitors.

b) DC link voltage ripple

The DC link voltage ripple of the MMC is much lower than that of the VSC DC capacitors of 2-level or NPC converters, because the MMC DC link voltage is almost the same as the sum of the output voltage of submodules in a phase leg. By shifting the output voltage pulse of each submodule, the DC link voltage ripple of the MMC is small.

5.6.8.2.4 Capacitance of the MMC submodule capacitor

The MMC submodule capacitance ~~shall~~ needs to be large enough to keep the voltage ripple of submodule capacitor within tolerable limits.

5.6.8.2.5 Control aspects

In addition to the control aspects of the VSC DC capacitors, the submodule capacitors have some control aspects described below.

- MMCs have many submodule capacitors, whose voltages ~~may~~ can tend to become unbalanced. Therefore, a balancing control is required in order to ensure that any unbalance does not become excessive and result in equipment ratings being exceeded.
- Discharge of the MMC submodule capacitors caused by a DC fault can be prevented by blocking the converter.

5.6.8.2.6 Harmonic coupling of different MMC substations connected to one DC circuit

Between the submodule capacitors of different substations, there are some semiconductor devices. So harmonic coupling is less serious for the MMC VSC systems than that of 2-level or NPC VSC systems.

5.6.9 DC reactor

For long-distance transmission, a DC reactor can be connected in series with a DC overhead transmission line or cable. Its main purpose is to reduce harmonic currents flowing in the DC line or cable.

The DC reactor also serves a secondary function in limiting short-circuit currents.

If a DC reactor is used in a VSC transmission system, its size can normally be considerably smaller than one used in an LCC HVDC scheme.

~~5.6.10 Common mode blocking reactor~~

~~A common mode blocking reactor consists of two magnetically coupled windings having the same self impedance. Due to the winding arrangement, the reactor provides low impedance for differential mode currents but high impedance for common mode currents. The reactor, therefore, serves to block the common mode currents and leaves the differential mode currents largely undisturbed and, in consequence, does not affect the dynamic behaviour of the transmission system.~~

~~The design of the reactor depends largely on the system grounding arrangement, transmission line type, environmental conditions and electrical stresses associated to the project.~~

5.6.10 DC filter

Filtering of harmonics on the DC side is achieved by the VSC DC capacitor, DC reactor, common-mode blocking reactor and, in some cases, by a dedicated DC filter.

The design principles of the DC filters for VSC-based HVDC systems are similar to those for LCC HVDC systems, as described in [5].

5.6.11 Dynamic braking system

In some VSC HVDC schemes, but particularly where the HVDC system is exporting power from a small islanded AC system with little or no load (for example an offshore wind farm), the

HVDC system ~~may~~ can be required to include a dynamic braking system, for example as a chopper connected to the DC terminals of the VSC system. The function of the dynamic braking system is to absorb and dissipate the power generated in the islanded AC system during faults in the receiving-end AC system, typically for durations of 1 s to 2 s.

There are several possible ways of implementing such a dynamic braking system but the valves in this system will, in general, be of similar design to the main VSC valves used for power transmission.

6 Overview of VSC controls

6.1 General

Although there are many configurations for voltage sourced converters (VSCs), they all can be considered to exhibit a common operating concept. All configurations possess a series inductive interface separating the switching valves from the AC system. The switching valves generate a fundamental frequency AC voltage from a DC voltage. The magnitude and phase of the fundamental frequency component of this AC voltage at the valve side of the series inductive interface can be controlled. The control of this voltage magnitude and phase is the essential controlling function common to all VSCs.

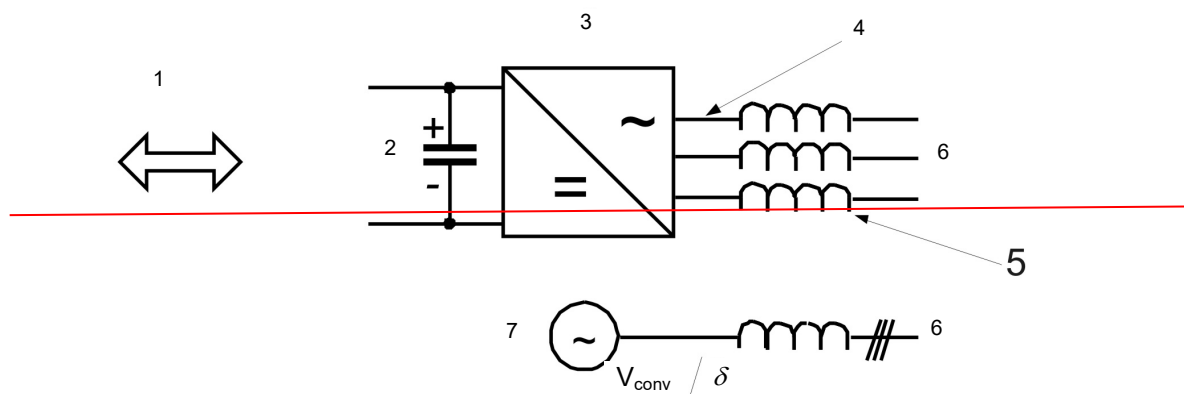

IEC 587/11

Key

- | | | | |
|---|--|---|--|
| 1 | active power | 5 | phase reactor and/or interface transformer |
| 2 | d.c. side | 6 | a.c. side |
| 3 | voltage sourced converter | 7 | equivalent representation of a VSC as a voltage behind an inductance |
| 4 | point of phase and magnitude control of a.c. voltage | | |

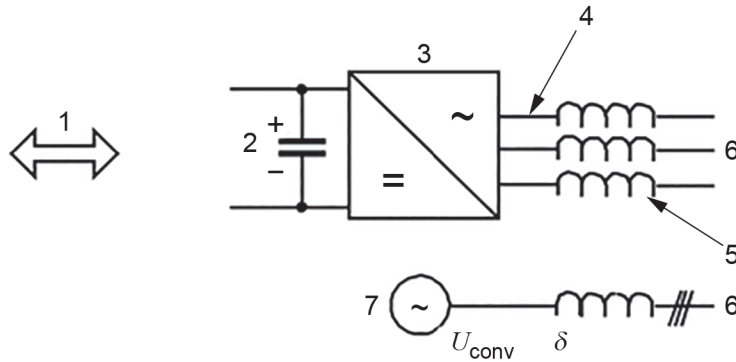

IEC

Key

- | | | | |
|---|--|---|--|
| 1 | active power | 5 | phase reactor and/or interface transformer |
| 2 | DC side | 6 | AC side |
| 3 | voltage sourced converter | 7 | equivalent representation of a VSC as a voltage behind an inductance |
| 4 | point of phase and magnitude control of AC voltage | | |

Figure 25 – Representing a VSC unit as an AC voltage of magnitude U and phase angle δ behind reactance

Figure 25 shows that a VSC can be represented as an AC voltage source of magnitude U_{conv} and phase angle δ behind the reactance. If the per-unit voltage U_{conv} is higher than the per-unit line side voltage U_L , then reactive power will be transferred into the line side similarly to an overexcited synchronous machine. Conversely, if the U_{conv} is low and less than the U_L , the VSC will be absorbing reactive power similarly to an under-excited synchronous machine.

The control of the phase angle δ is achieved by shifting the phase of the fundamental frequency AC voltage with respect to the phase locked loop normally synchronized to the AC side voltage. Regulating the phase angle δ causes active power to be transferred through the VSC, because a phase angle in fundamental frequency voltage is developed across the interface reactor so that power flows into or out of the VSC.

A VSC therefore has the capability of acting as a rectifier or as an inverter, and/or as a generator or an absorber of reactive power. It is the control of the magnitude and phase of the converter voltage U_{conv} that dictates the strategies for controlling voltage sourced converters.

6.2 Operational modes and operational options

~~The normal way of a.c. side voltage control is achieved by controlling the d.c. side capacitor voltage. In turn,~~ The DC side capacitor voltage is varied by pumping power from the AC side into it or out of it. If power is pumped into the capacitor, its charge will increase and consequently so will its voltage. If power is taken from the capacitor, its voltage will decrease. Power can be taken from or fed into the AC side by varying the phase angle δ , as described above. In this way, DC voltage control is achieved by regulating AC phase angle δ .

Control of the magnitude and phase of the converter voltage U_{conv} for VSC transmission applications is usually achieved by means of vector control strategy. With vector control, three-phase currents are transformed to d and q axis quantities based on the conventional abc to dq transformation, synchronized to the AC side three-phase voltage through a phase locked loop (PLL). The d and q axis voltages generated by the vector controls are transformed to three-phase quantities and converted into line voltages by the VSC as shown in Figure 26.

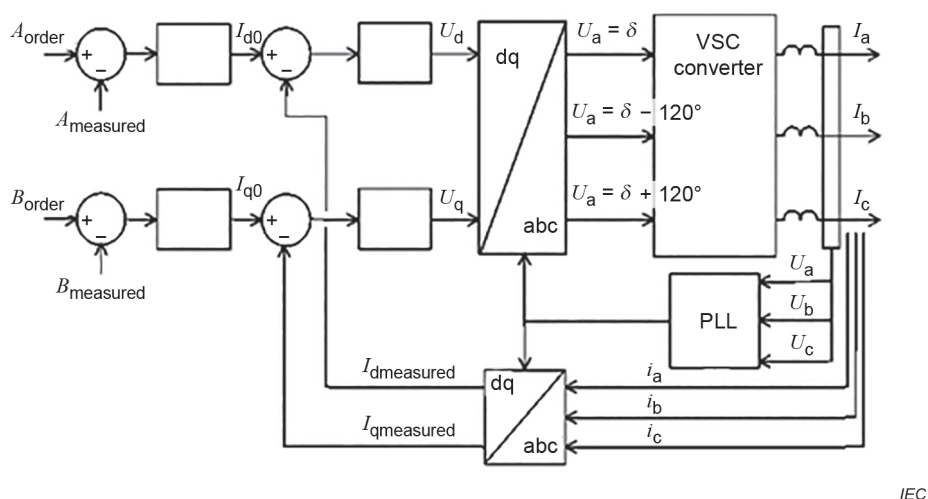

Figure 26 – Concept of vector control

With VSC converters, the degrees of freedom available are as follows:

- frequency control by direct control of the main firing oscillator;
- the various control options provided by phase shifting the AC voltage that is generated by the VSC;
- the various control options provided by control of the magnitude of the AC voltage that is generated by the VSC.

These degrees of freedom translate into the various control functions discussed below.

6.3 Power transfer

6.3.1 General

To control power into or out of the AC system, the VSC ~~shall~~ needs to have a means for transferring power into or out of the DC side without over- or under-charging the capacitor. In a VSC transmission scheme, this means that the converters at the two ends of the scheme ~~shall be~~ are controlled to work together. Generally, one of the two converters will have as part of its objective the control of the DC voltage.

Power control is achieved by regulating the phase angle δ of the fundamental frequency component of the AC voltage at the converter side of the interface reactance as shown in Figure 27. Power is drawn from or pushed into the AC system depending on whether δ lags or leads the phase angle of AC bus voltage.

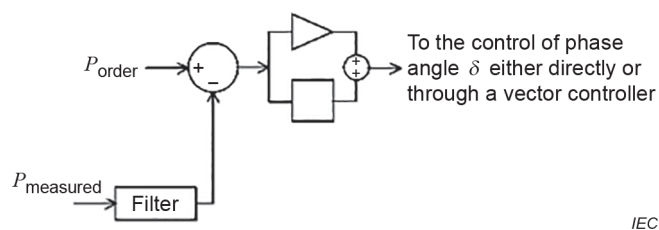

Figure 27 – VSC power controller

Power is one parameter that can be controlled with fast response to improve the performance of the AC transmission system under transient conditions. This can be used to increase AC

system damping of electromechanical oscillations, as well as to improve the transient stability of the power system following a fault.

6.3.2 Telecommunication between converter stations

For VSC transmission control, there is no need for fast telecommunication signals between the ends. However, telecommunications between the converters ~~may~~ can be applied for conditions such as the following:

- when power control is required between converters for a multi-terminal configuration, such as for coordinated damping of electromechanical oscillations;
- when damping of electromechanical oscillations is required at the converter that is not controlling power;
- if it is desired to reconfigure the control modes between converters.

The normal use of communication is however between the converter stations and dispatch centre which requires indications, status signals and alarms for operation of the system.

6.4 Reactive power and AC voltage control

6.4.1 AC voltage control

AC voltage control is achieved by regulating the magnitude of the fundamental frequency component of the AC voltage generated at the VSC side of the interface reactor and/or transformer as shown in Figure 28.

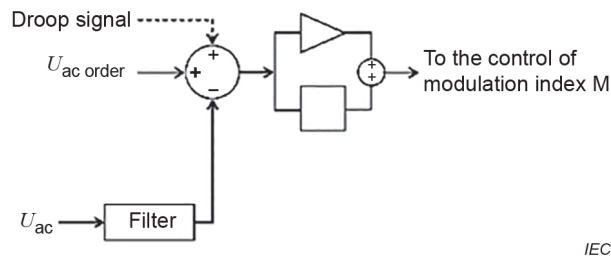

Figure 28 – AC voltage controller

If the VSC is feeding into an isolated AC system with no other form of active power source of any significance, the AC voltage controller will automatically control power to the load. This assumes another converter, such as the sending end of a VSC transmission link, independently controls the DC side voltage.

6.4.2 Reactive power control

The need to use reactive power control arises when other nearby controllers are acting to maintain AC voltage. To avoid interference between the various controllers, it is preferable to retain those VSCs not needed for AC voltage to provide reactive power control.

If all VSCs in close proximity to each other are controlling the same quantities, then it ~~may~~ can be possible for each to participate in AC voltage control through a carefully designed droop characteristic. However, if the controlling functions of the VSC are quite different, such as separate and independent power controllers, the droop characteristic ~~may~~ can be difficult to define. Under these circumstances, a reactive power control ~~may~~ can be preferable, with the settings either at zero MVARs or slowly controlled by a joint VAR controller or an order from the SCADA system.

6.5 Black start capability

To supply an AC load that has no other source of generation, the rectifier connected to the main grid or generation ~~may~~ can have the following controls:

- DC voltage control;
- AC voltage or reactive power control at the sending end system.

The receiving end ~~should~~ needs to have controls as follows:

- frequency control (defining the frequency of the load);
- AC voltage control of the receiving end system.

With these control modes in place, the load-side AC voltage and frequency can be controlled within acceptable limits. As the load changes, the transmission self-regulates the power flow simply by maintaining AC voltage and frequency.

If an AC synchronous generator or an AC transmission line is added or switched on-line so that the VSC transmission is relieved of providing the frequency control and all the AC voltage control to the load, the firing pulses ~~may~~ can be switched from an independent clock to being phase locked onto the AC voltage. Alternatively, a droop characteristic for the frequency control and the AC voltage control ~~may~~ can be invoked so that the VSC transmission can operate in concert with the active system that the receiving end has changed to.

6.6 Supply from a wind farm

~~When~~ DC transmission is ~~required~~ sometimes used to ~~bring~~ export power from an isolated wind farm to an AC grid, ~~VSC transmission can be integrated into the wind turbine design for maximum performance and economy.~~ This technology ~~may~~ can be particularly applicable for offshore wind farms. This is an important and fast-growing use of VSC transmission, which is described in detail in [6].

At the sending end, the VSC converter controls the AC voltage and frequency of the system. The converter at the AC grid side transfers the incoming DC power to the AC grid. The AC grid ~~shall be~~ is usually strong enough to accept fluctuating wind farm infeed.

One important aspect is how to handle energy surplus in case there is a temporary network disturbance where the AC grid is unable to absorb the energy from the wind farm.

Alternatives to handle this energy surplus include to store the surplus energy in the wind turbine by temporarily increasing rotor speed or to dissipate the energy via resistors, for example

- in the wind turbine itself,
- on the offshore AC grid, or
- on the DC side of the VSC transmission, via a dynamic braking system.

7 Steady-state operation

7.1 Steady-state capability

The VSC can be considered as an equivalent of a synchronous machine, which has the capability of individually controlling active and reactive power, albeit normally with limited inertia.

The active and reactive power can be controlled simultaneously and independently of each other as described in 6.3 and 6.4.

The PQ capability diagram of a VSC shows its possible operating regime. The diagram normally gives the capability at the AC interface point. When active output power P is positive, the VSC is operated as an inverter, either in capacitive mode, when Q is positive, or in inductive mode when Q is negative. When P is negative, the VSC is operated as a rectifier, either in capacitive or inductive mode. A simplified PQ diagram at minimum (U_{\min}) and maximum (U_{\max}) AC grid voltage, in which filters are not considered, is shown in Figure 29. The VSC can be operated within all four quadrants of the PQ plane.

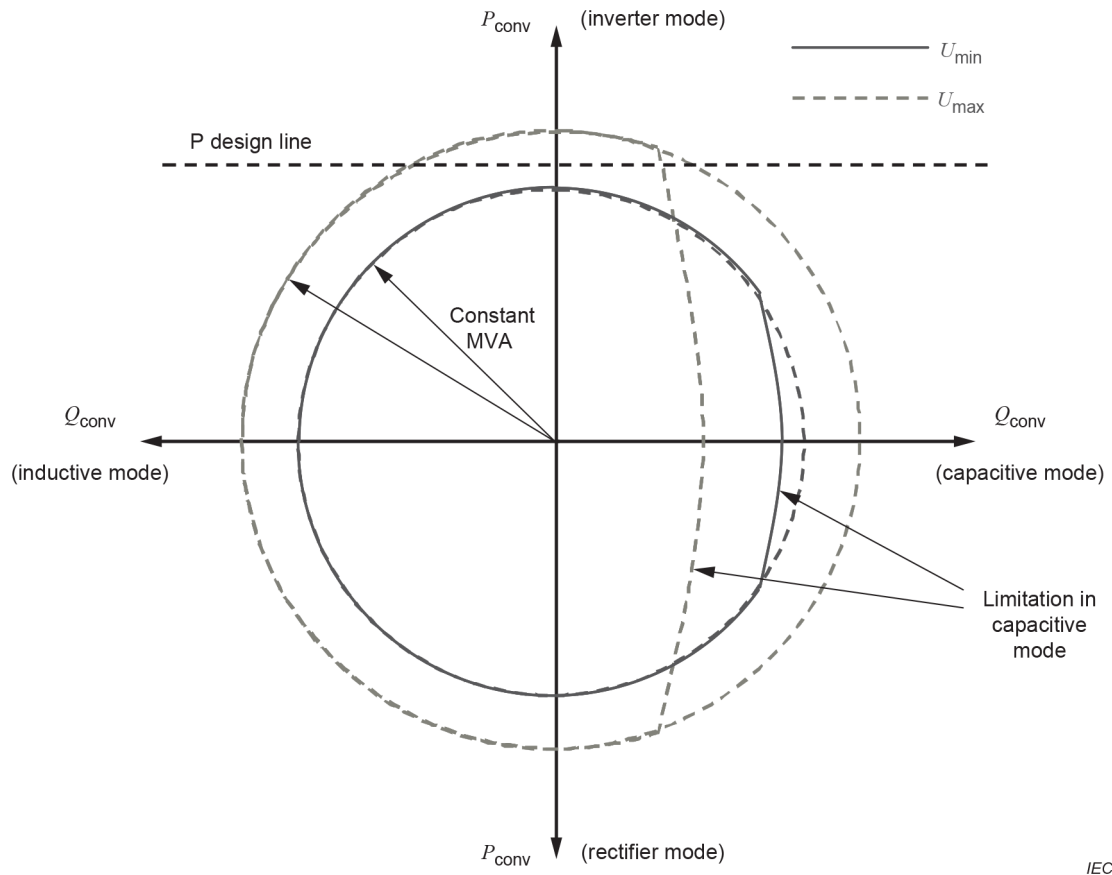

Figure 29 – A typical simplified PQ diagram

The PQ diagram shows that the capability of the VSC depends on the AC grid voltage. At low AC voltage, a higher current is necessary to produce a given output power, and the output capability is limited by the current capability of the converter. Therefore, if an interface transformer is provided, the transformer ratio can be used to optimize the PQ characteristic. With an on-load tap changer, the transformer ratio can be continuously optimized to maximize the steady-state power capability of the converter. Note that the centre of the circles is dependent on the design of the converter, and ~~may~~ might not be at the origin of the diagram.

The diagram also indicates an active and a reactive power design line. The design line is the maximum power rating of the VSC and it is mainly determined by the maximum current for which the converter is designed. In addition to the limitation by the maximum converter current, there might be other design limitations, for example affecting reactive power capability. In capacitive mode, the peak converter AC voltage U_{conv} needs to exceed the peak line-side AC voltage U_L ; however, U_{conv} generally cannot exceed $0,5 U_d$. Therefore, the capacitive output rating is limited, particularly at high values of U_L . The active power design line in the PQ diagram indicates the desired rated power of the VSC. In the example shown, the required power capability in inverter operation is less than the potential capability of the VSC.

7.2 Converter power losses

One of the main obstacles to using voltage sourced converters in bulk power transmission is the comparatively high power losses, including IGBT, filter and interface transformer losses, in comparison with LCC HVDC. However, VSC technology is developing rapidly and power losses are decreasing.

The 2-level VSC topology is attractive because of its simplicity. However, the switching frequency chosen ~~shall be~~ is usually comparatively high in order to keep the current ripple reasonably low, and this will result in high switching losses. One way of reducing the losses is to use more advanced converter topologies, but at the expense of greater complexity. The on-going semiconductor device development and converter topology optimization will contribute to a further reduction in overall losses in the future.

In common with LCC-HVDC, it is recommended that power losses in VSC be determined by a combination of calculation and factory measurement, rather than direct measurement on site.

For most equipment, the overall principles are the same as described in IEC 61803 [7] for LCC-HVDC, although adjustments need to be made to reflect, for example, differences of harmonic spectra. For converter valve losses, IEC 62751 (all parts) [8] is used instead of IEC 61803 (see also [9], [10]).

The power losses in the VSC substation depend on a variety of operating conditions, but chiefly the real transmitted power and the reactive power absorption or generation. In general, losses in the VSC substation will be lowest when the real and reactive power are both close to zero and will increase progressively as either the real or reactive power is increased.

8 Dynamic performance

8.1 AC system disturbances

Fast control of active and reactive power of VSC systems can improve power grid dynamic performance under disturbances. For example, if a severe disturbance threatens system transient stability, fast power run-back and even instant power reversal control functions can be used to help maintain synchronized power grid operation. VSC systems can also provide effective damping to mitigate electromechanical oscillations by active and reactive power modulation.

A VSC system can support the network during disturbances in the following ways:

- emergency power control;
- voltage support;
- short-circuit current contribution.

The ability of the VSC converter to rapidly control active power makes it a tool for emergency power support during network disturbances where power can be transferred to/from the disturbed area in a controlled way. This is also possible with LCC HVDC but VSC HVDC has better possibility to rapidly reverse power.

The VSC converter can operate as a local STATCOM with possibilities for fast voltage support. This can be used to support the connected AC network during a fault or disturbance where the AC voltage drop can be limited by the converter.

The short-circuit power contribution from a VSC converter can be controlled. In systems where the short-circuit currents are already high, there is a large benefit in a low contribution. In systems fed solely by the VSC converter, higher short-circuit currents are desirable in order to have the standard overcurrent protections in the AC network operating as normal. The

maximum short-circuit current is normally limited by the dynamic limitations of the converter which are equal to or higher than rated current.

8.2 DC system disturbances

8.2.1 DC cable fault

Mechanism: cable or junction failure, external mechanical stress.

Type: permanent fault, for which repair is needed.

Detected by: DC cable faults are detected by measuring the DC voltage and current, both amplitude and rate of change.

Protective actions: since any fault in a cable ~~shall~~ needs to be thoroughly investigated and will most likely require a lengthy repair, the DC link ~~has~~ needs to be tripped when such faults are detected. It is therefore very important to correctly detect these faults.

8.2.2 DC overhead line fault

Mechanism: insulation failure between one DC conductor and ground or between the two DC conductors, due to lightning strike, brushfires, trees, pollution, external mechanical stress, etc.

Type: can be a non-permanent fault, but ~~may~~ can be permanent if the DC insulators have been damaged.

Detected by: DC overhead line faults are detected by measuring the DC voltage and current, both amplitude and rate of change.

Protective actions: it ~~should be~~ is noted that when insulation breaks down on overhead transmission lines, the VSC's free-wheeling diodes normally continue to feed current into the fault even if the converter is blocked. This means that besides blocking the converters, they normally also need to be isolated from the AC system by opening the AC breakers, to enable the air insulation to de-ionize. After this, re-starting the system ~~may~~ can take a time of ~~the order of 10 s~~ a few seconds, for example 2 s to 4 s. Another method is to introduce DC breakers and open these when a fault is detected, or to use a special VSC topology which gives an inherent capability to clear DC line faults (see 5.3.3).

8.3 Internal faults

VSC systems ~~should be~~ are designed, where practical, to permit operation of the rest of the system to continue in the presence of internal faults within one converter station.

A typical protection diagram for a VSC substation is shown in Figure 30; however, VSC substation protection against internal faults will differ depending on the VSC design and protection philosophy. Therefore, the protection system shown in Figure 30 is only representative.

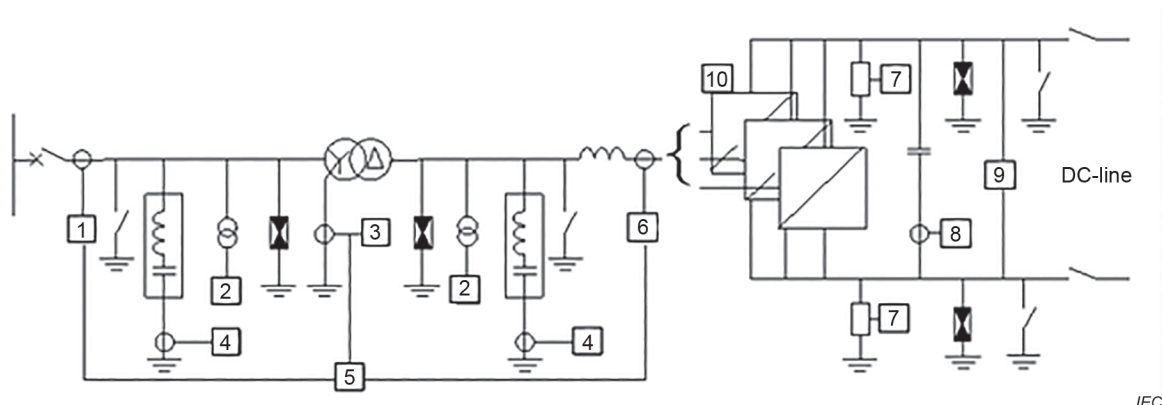

Figure 30 – Protection concept of a VSC substation

Typical protective functions include the following:

- a) overcurrent protection of AC circuit breakers;
- b) abnormal AC voltage protection;
- c) earth fault protection;
- d) AC filter protections;
- e) differential protection;
- f) overcurrent protection of the converter;
- g) abnormal DC voltage protection;
- h) overcurrent protection of the VSC DC capacitors;
- i) DC discharge unit;
- j) valve protection, for example in the valve gate electronics.

Depending on the VSC substation design and the application, the following additional protections are usually applicable:

- k) loss of cooling protection;
- l) DC line/cable earth fault protection/supervision;
- m) frequency protection;
- n) impedance relay protection;
- o) fire protection;
- p) mechanical protection.

9 HVDC performance requirements

9.1 Harmonic performance

Many aspects of the harmonic performance of a VSC transmission scheme are similar to those of an LCC HVDC scheme, as described in IEC TR 62001-1 [4] and IEC TR 62001-5 [11]. The main difference between the two comes from the different switching strategies used in the different types of converter. Different VSC topologies also have widely differing harmonic performance.

In common with LCC converters, the interaction of VSC converters with the network is quite complex and, for an accurate calculation, the pre-existing (background) harmonics on the AC network need to be taken into account and the network impedance at harmonic frequencies is very important. Pre-existing harmonics ~~may~~ can be damped or amplified due to operation of the VSC. In order to perform these calculations, accurate information about background

harmonic distortion and network impedances for the frequency range of interest is necessary. More guidance on these topics can be found in IEC TR 62001 (all parts) [12].

VSCs generate harmonics on both the AC and DC sides. Measures ~~shall~~ need to be taken to limit the amplitude of the harmonics entering the AC network and the DC line. The main methods of reducing the harmonics to acceptable levels are as follows:

- pulse width modulation (PWM) techniques;
- multi-level techniques;
- harmonic filters (series and/or shunt combinations);
- multi-pulse (12-pulse, 24-pulse, etc) techniques;
- combinations of the above.

Since a VSC can operate at any desired power factor, the design of the filters is normally based only on harmonic performance and (unlike for LCC HVDC) is not affected by reactive power considerations. Some multi-level converter topologies ~~may~~ can generate sufficiently low levels of harmonics that harmonic filters can in some cases be omitted.

9.2 Wave distortion

The individual voltage distortion factor (D_n), total harmonic distortion (THD), telephone harmonic form factor (THFF), telephone influence factor (TIF) and total harmonic current factor (IT), as defined in IEC TR 62001-1 [4], are relevant also to VSC transmission schemes.

It ~~should be~~ is noted that, with VSC technology, it is relatively easy to shift the spectrum of harmonics to higher orders of the fundamental frequency. When setting the distortion limits for a VSC transmission scheme, it ~~may~~ can be appropriate to assess harmonics to a higher order than has been the case for LCC HVDC schemes, for example to increase the order to be included from the 50th harmonic to, for example, the 100th harmonic.

It also ~~has~~ needs to be noted that the accuracy of modelling of harmonic impedance decreases at such high frequencies.

9.3 Fundamental and harmonics

9.3.1 Three-phase 2-level VSC

Single-phase AC output for a 2-level converter is shown in Figure 16.

The AC wave shape at a VSC phase unit output ~~may~~ can consist of a sequence of square waves, as shown in Figure 31. Many different modulation methods can be used to control the converters to achieve a specific wave shape. The most commonly used method is the carrier-modulated method (voltage reference as sine wave or other with a triangular carrier wave shape). Some typical modulation strategies used with 2-level VSC are discussed in Annex B.

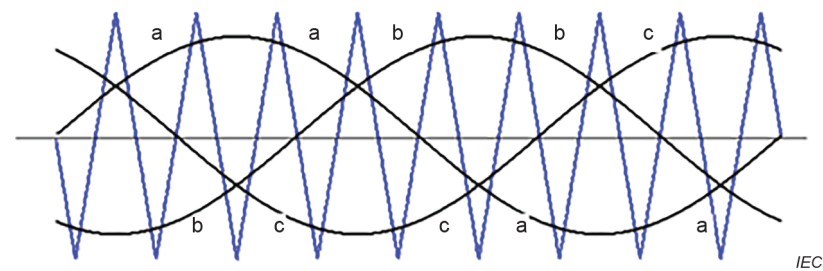

a) Control signals for a PWM VSC

b) Phase a output voltage (V_{am})

Figure 31 – Waveforms for three-phase 2-level VSC

9.3.2 Multi-pulse and multi-level converters

Multi-pulse and multi-level converter topologies can also be used to reduce the harmonic output. The harmonics are calculated by Fourier analysis of the individual waveforms.

The individual levels of such converters are switched to obtain desired output voltage at the AC and DC terminals of the converters. The methods for switching individual levels can be distinguished in two main categories:

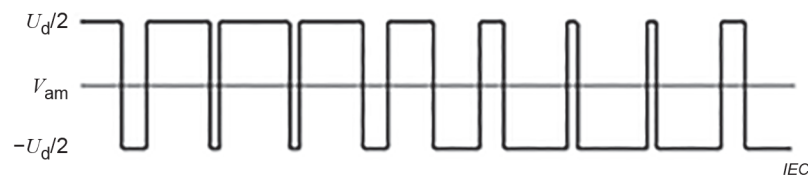
- methods resulting in a random type pulse pattern;
- methods creating a fixed pulse pattern (for given output voltages).

Random type pulse patterns distribute the harmonic distortion over the full frequency range, resulting in a "white noise" with moderate amplitudes. Due to their random nature, these harmonics are not easy to predict on a pure analytical basis. In contrast, fixed pulse patterns can be easily predicted and analysed.

9.4 Harmonic voltages on power systems due to VSC operation

One possible method for calculating the harmonic performance of the VSC is to consider it to be a harmonic generator of equivalent voltage E_n at each individual harmonic. At the point of common connection (PCC) of the VSC and the power system, the equivalent circuit is shown in Figure 32, where $Z_{S(n)}$ is the system impedance at the harmonic n and $Z_{(n)}$ is the harmonic impedance of the VSC, including the interface transformer, phase reactor and AC filters (as appropriate). If shunt filters are used either as part of the network or as part of the converter, they ~~should be~~ are included in respective impedance.

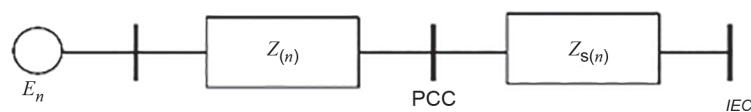

Figure 32 – Equivalent circuit at the PCC of the VSC

Since both $Z_{(n)}$ and $Z_{S(n)}$ are a complex impedance, a resonance ~~may~~ can occur. Therefore, it is essential to have knowledge of the purchaser harmonic system impedance at the PCC.

9.5 Design considerations for harmonic filters (AC side)

If the evaluation indicates that the VSC contribution to harmonics at the PCC will exceed the permissible level, harmonic filters ~~shall~~ need to be designed and installed to keep the harmonics within the required limits. The filter configuration for the VSC is determined in a similar manner as those for LCC HVDC; see IEC TR 62001 (all parts). However, one important difference is that the VSC behaves as a harmonic voltage source on the AC side, and hence the series filtering action of the phase reactor and associated equipment is more important than the effects of any shunt filters.

9.6 DC side filtering

If the VSC is part of a DC transmission scheme connected by a DC overhead line, or a combination of DC cable and DC overhead line, its DC-side harmonics ~~may~~ can interfere with other equipment and substations near the transmission line. VSC systems frequently use land cables which ~~may~~ can be installed in trenches alongside telecommunication cables. If there are copper telecommunication cables close to DC cables over a long distance, the potential interference between these cables ~~shall be~~ is usually considered. The frequencies used in commercial voice transmission range from 200 Hz to 3 500 Hz. Telephone noise evaluation is performed according to various weighting factors (such as CCITT and BTSEEI) according to local practices. The coupling between power circuits and telephone circuits is through both electric and magnetic fields. However, unless the spacing between the two circuits is small, the magnetic coupling predominates and the electric coupling is negligible. For bipolar DC lines, this coupling is usually calculated using the "equivalent disturbing current" [5].

If filtering is required on the DC side, a common mode reactor, DC reactor, or a DC filter can also be used to perform the role of RF filtering.

10 Environmental impact

10.1 General

Clause 10 covers the main environmental impact resulting from the development of a VSC substation. The environmental aspects discussed are audible noise, visual impact, EMF and EMC. Other factors of a more generic character that result from VSC substation development are not covered, nor are the impacts from the development of a cable or overhead line system. End-of-life issues like recycling and disposal are similar to those for an LCC HVDC scheme, as are power losses.

10.2 Audible noise

IEC TS 61973 [13] covers in a comprehensive manner the audible noise related to line commutated HVDC converter stations, and is applicable also to VSC transmission. Audible noise theory is, therefore, not covered here.

The noise characteristics of the cooling equipment and auxiliaries are similar to those used in a conventional AC substation. Dependent on the converter topology used, the noise characteristics of the transformer ~~may~~ can be similar to those of a substation transformer, as the use of filters on the converter side results in a very low level of harmonics in the transformer. For some converter designs, the noise characteristics ~~may~~ can be different. For converters using valves of the switch-type, the filters, VSC valves, phase reactor and VSC DC capacitors typically have noise components at higher frequency than for an LCC HVDC scheme. For converters using valves of the controllable voltage source type, the noise spectrum ~~may~~ can have a significant component at fundamental frequency, with higher harmonics being more characteristic of "white noise".

Noise attenuation can be achieved by a number of reduction measures that can be incorporated into the design of a VSC station. For many components, such as transformers,

cooling equipment and auxiliaries, the measures taken to reduce noise are similar to those for a conventional AC substation.

10.3 Electric and magnetic fields (EMF)

The electric and magnetic fields (EMF) associated with a VSC scheme can be separated into AC and DC fields. The AC fields are produced by the AC components of the substation, and the connection between the VSC and the AC grid. The DC fields (also referred to as static fields) are produced by the cable/OH line, by connections to the DC equipment, and by the DC equipment itself.

In general, the electric and magnetic fields around a VSC facility, including the substation, connections and DC overhead line or cable, are similar to those for an LCC HVDC scheme.

10.4 Electromagnetic compatibility (EMC)

The operation of high-voltage electrical equipment can generate electromagnetic fields over a wide range of frequencies, from power frequencies to television frequencies. It is possible for electrical or electronic equipment in the vicinity of such electromagnetic fields to be affected, or to have their proper operation interfered with. Interference limits imposed on facilities typically consider

- radio interference (RI),
- television interference (TVI),
- telephone interference (see Clause 9), and
- power line carrier interference (see Clause 9).

VSC valve switching can generate high frequency emissions up to several hundred MHz. The VSC design ~~shall ensure~~ usually ensures that such noise does not cause unacceptable interference for others. Different mitigation methods can be employed, such as proper grounding, the use of passive radio interference filters, and shielding of the sources by EMC barriers.

Radio interference is associated with noise in the frequency range of 150 kHz to several hundred MHz. Television interference, on the other hand, results from noise in the frequency range 54 MHz to 1 GHz. Consequently, the whole frequency range up to 1 GHz ~~shall~~ needs to be taken into account when designing the VSC substation.

Electrical interference and noise are transmitted in three forms: radiated, conducted and electro-magnetically induced. For the VSC, conduction on power lines is a more significant source than radiation. Housing a VSC in a metal enclosure or valve hall generally reduces the radiated component of disturbances.

The conducted phenomena consist of two categories, commonly known as the differential mode and the common mode. The differential-mode disturbance is a current or a voltage measured between the power lines of the VSC, while the common-mode is a current or a voltage measured between the power lines and ground. Any filter design ~~has~~ needs to take into account both modes of noise.

The path of the common-mode disturbance is through stray capacitance. These stray capacitances exist between any system components and ground. In close proximity to the source, other predominant coupling paths ~~should be~~ are usually considered, such as electric fields (high impedance field) and/or magnetic fields (low impedance field). Except in far field conditions, one of these will be predominant.

A proper design of a VSC valve and converter layout can reduce the disturbance emissions at their source. In addition, it ~~may~~ can be necessary to use filters. Emission level can be assessed by simulation and measurement in-situ.

IEC 61000 (all parts) [14] on electromagnetic compatibility covers emission and immunity for phenomena in the 0 GHz to 400 GHz frequency range. This range is split into several frequency bands, according to measurement techniques.

11 Testing and commissioning

11.1 General

Clause 11 provides general guidelines for testing and commissioning of VSC transmission systems. Emphasis has been put on subsystem and system tests rather than those for components.

Testing and commissioning are part of a process that begins in the factory and ends with the handing over of the equipment for commercial operation. There are two distinct phases: factory or off-site testing, and commissioning testing. Off-site testing is usually performed to prove that equipment, including the control system, meets the design criteria. Commissioning tests are performed after the equipment has been delivered to the site and installed. The tests are organized to test subsystems, systems and overall performance.

As a general rule, all parties involved in the project ~~should~~ needs to be included in the tests and all responsibilities clearly defined.

General requirements for system testing are ~~similar to those~~ described ~~for LCC-HVDC~~ in [15].

11.2 Factory tests

11.2.1 Component tests

These tests concern the verification of the single components, including control and protection equipment, before they are sent to site. They ~~may~~ can be subdivided into routine tests, aimed essentially at quality control, and type tests which verify that a component has been properly designed to sustain the stresses from potential transients and service conditions. Factory testing of VSC converter valves is covered by IEC 62501 [16]. Traditional components such as switchgear, transformers, capacitors, capacitor fuses, reactors, resistors, insulators, voltage and current transformers, surge arresters, etc, are covered by [3], in which the available standards (IEC, IEEE, ANSI) are pointed out and the special tests are introduced.

11.2.2 Control system tests

As with the controls for LCC HVDC systems, the control system for a VSC transmission system, including hardware, software and documentation, can be tested and verified in a factory system test (FST). A real time simulator will be required that can represent power components and parts of the AC system in a sufficiently detailed way. Every effort ~~should be~~ is usually made to test as complete a system as practical, including redundancy, so as to minimize work on site. Factory system testing is an extensive and thorough check of the control and protection system under normal and fault conditions, without the constraints imposed by the real system. Selected on-site system tests will repeat some of the factory system tests, but will include the actual transducers and main circuit equipment, as well as actual system conditions (as permitted within system constraints). All software and hardware functions, including redundancies, ~~should be~~ are usually tested before the equipment is shipped to site for installation and commissioning.

Besides simulator tests identical to those for LCC HVDC, other tests ~~should~~ need to be considered that account for the additional modes of operation possible with a VSC. Each mode ~~should be~~ is usually tested both in the factory and during commissioning (e.g., operation of the converter as a STATCOM, black start capabilities, and feeding a passive network). The results obtained from real time simulator tests and system studies (in particular the dynamic performances studies) are the main references used to define the commissioning plan and validate the test results in the field.

11.3 Commissioning tests/system tests

11.3.1 General

Commissioning tests are organized in a succession of phases.

The first phase is the so-called "precommissioning tests" executed on single station components in order to check their condition and functionality after transport and assembly. This phase is followed by the "subsystem tests," which test several components working together to perform a specific function. These are followed by the "system tests," which involve all converter stations and full power transmission. The system tests require careful coordination between all interested parties, in particular the system operators, utilities and industrial customers that could be affected by the tests.

During inspection and testing, all applicable health, safety and environmental requirements and regulations ~~shall~~ need to be followed. Any deviations ~~should be~~ are discussed and resolved at site meetings. Often there is an overlap between commissioning and installation, especially in the area of cable termination. Care ~~must~~ needs to be taken when interconnected subsystems are energized and started up that personnel are notified so that no potentially hazardous conditions exist. For an efficient process, it is important to complete as many as possible of the equipment pre-commissioning checks before energization of the equipment. Most utilities have extensive safety rules that protect workers from accidental electrical contact.

11.3.2 Precommissioning tests

Precommissioning consists mainly of inspection and equipment tests. Equipment tests include electrical and mechanical tests and simple functional tests confined to a single installed unit. The purpose of these tests is to check the condition of the equipment and verify proper installation. If normal auxiliary power is not yet available, electrical tests can be performed with portable or temporary power supplies. At this stage, settings are verified in protection and control equipment.

In those cases where disconnection and reconnection would be required for the equipment tests, precommissioning tests on main circuit equipment ~~should be~~ are performed before the main conductors are connected. Equipment tests ~~should be~~ are performed as soon as possible after installation, and according to the manufacturer's recommendations.

11.3.3 Subsystem tests

Subsystem tests verify the proper operation of a group of interconnected or related equipment. Subsystem testing ~~should~~ needs to be done in stages from small to progressively larger subsystems, and ~~should~~ to check as many functions as possible.

Typical subsystem tests are

- subsystem functional testing,
- start-up of auxiliary systems, and
- low-voltage energization.

11.3.4 System tests

11.3.4.1 General

The system tests involve operating the converter(s) in conjunction with the interconnected AC transmission system. These tests ~~should~~ are not only checked for proper performance of the automatic controls during normal changes in references, set points or operating modes, but also take place, in so far as possible, under different network conditions. System tests ~~should~~ need also to include selected disturbances to verify dynamic performance and robustness. Disturbances can consist of nearby capacitor bank switching, transformer energization, line

switching, generator tripping, step responses, or even staged faults where specified, and ~~should~~ cover the most critical conditions evidenced by the system studies and by simulator tests, in so far as the networks allow. Some tests with high potential impact ~~may~~ can require special provisions to mitigate the possible adverse system impact of large reactive/active power variations. These will require tight coordination with the transmission system operator (TSO)/utilities of AC networks to which the VSC transmission system is connected.

Usually, tests with lower impact on AC networks are performed first, followed by the more onerous ones.

11.3.4.2 High-voltage energization

When all prerequisites for high-voltage energization have been completed, operational authority is transferred to system operators to ensure that all safety rules are followed and that any system constraints are observed. Operational procedures ~~should~~ need to be formalized beforehand. High-voltage energization is preceded by final trip tests and "dry run" tests where the operators execute the procedure without actually energizing the equipment.

Energization of AC equipment follows a step-by-step sequence for the AC buses, bays, filters and transformers. This ~~may~~ can require temporary disconnection of some high-voltage terminations where disconnect switches are not provided. Equipment ~~should be~~ is initially energized for several hours. Checks are made for corona and any abnormal audible noise. Phasing and phase rotation are rechecked with full voltage. During filter energization, unbalance protections are checked and load checks are made. Visual inspections of all equipment and surge arrester counters are made before and after energization.

Energization of the converter and DC equipment follows that of the AC equipment. In most cases, valve cooling ~~should~~ needs to be running before energizing the converter. With the VSC, the connected DC side equipment (i.e., DC buswork, DC capacitors and DC transducers) is energized through the valve anti-parallel diodes when the main AC breaker is closed thereby energizing the converter.

As an additional check, the converter ~~may~~ can be energized via the DC side, with the AC connection open. A special DC power supply could be provided for this purpose, or the converter at the opposite end of the link could be used as a rectifier to provide this function.

During energization, DC voltage measurements and status signals from individual semiconductor positions ~~should be~~ are checked via the valve monitoring.

If other converters or DC cables are included in the particular application, they ~~should be~~ are initially energized separately while isolated from the other converter(s) and interconnecting cables or buswork.

11.3.4.3 Converter operating tests

11.3.4.3.1 General

Once the converter and DC equipment have been energized and checked out, the converter can be deblocked, sending switching pulses to the valves. Initially, this is performed one converter at a time, with the VSC operated in AC voltage control or reactive power control. The purpose of the converter operational tests is to check that the converter operates properly with the AC network.

During converter operational testing all subsystems, for example controls, transducers, auxiliaries and main circuit equipment, are tested together for the first time.

Typical tests performed during converter operation are explained in 11.3.4.3.2 to 11.3.4.3.8.

11.3.4.3.2 Sequences

It is checked that breakers, disconnects and deblock/block and trip sequences operate properly in response to manual, automatic or protective orders. Check that the initial operating condition is neutral, minimizing the disturbance to the network, for example automatic connection of filters, if any, with net zero reactive power exchange through counterbalancing VSC absorption.

11.3.4.3.3 DC voltage control

It is checked that the DC voltage is controlled to its reference voltage, and that all levels of DC voltages are balanced.

11.3.4.3.4 Measurements

It is checked that all controls, indications and measurements have correct polarity, phase and scaling. Take selected measurements of AC and DC harmonics and distortion.

NOTE Final measurements are usually reserved for acceptance tests.

11.3.4.3.5 Reactive power control

It is checked that the reactive power control, if relevant, follows the reference at the selected ramp rate for both inductive and capacitive ranges. Check proper converter reactive power limitations.

NOTE Operating restrictions on AC voltage ~~may~~ can limit the amount of reactive power that can be exchanged with the AC network.

11.3.4.3.6 AC voltage control

It is checked that the voltage is controlled to the reference, if relevant, and that the reactive power is stable. Vary slope, reference, deadband and voltage control modes, as provided. Check stability with the AC network by reference step response, capacitor bank switching and/or AC line switching.

11.3.4.3.7 Load test

The capability of the cooling equipment is checked, primarily for the VSC valves. Observe the temperatures and sequencing of the cooling equipment as the load is increased.

~~NOTE~~ Operating restrictions on AC voltage ~~may~~ can limit the amount of reactive power that can be exchanged with the AC network, and special provisions ~~shall~~ need then to be made to reach full output.

11.3.4.3.8 Disturbance tests

In addition to the testing of the step responses to regulator references, the converter and its controls ~~should be~~ are tested for various internal disturbances (e.g., auxiliary supply changeover, control system changeover, and external disturbances in the AC transmission system) to verify proper performance, stability and robustness. External disturbances can consist of switching nearby capacitor banks, transformers, transmission lines, or tripping generators.

11.3.4.4 Transmission tests

11.3.4.4.1 General

Transmission tests involve operation of converters that work together to control the power flow. Such testing requires a very high degree of coordination with the system operator (dispatcher).

Typical tests performed during transmission testing are as described in 11.3.4.4.2 to 11.3.4.4.11.

11.3.4.4.2 Sequences

It is checked that breakers, disconnects and deblock/block and trip sequences operate properly in response to manual, automatic or protective orders. It is checked that the initial operating condition is neutral, minimizing the disturbance to the network, for example zero net reactive or active power exchange.

11.3.4.4.3 DC voltage control

High-voltage DC cables, bus work or lines interconnecting the converters are energized. It is repeated with the other converter connected. Depending on application and protective strategy, it is checked that the DC voltage is controlled to a reference during power transfer and blocking/tripping of one of the other converters.

11.3.4.4.4 Power control

It is checked that the power flow and power ramp rate follow the reference values. The power control stability by step response or system disturbance is checked, such as line switching. Transmission in both directions is checked. Proper converter real power limitations are checked.

11.3.4.4.5 Reactive power control

If relevant, the joint operation of the reactive power control and active power control at the different converters is checked by changing their respective references during the different operating modes. Proper converter reactive power limitations are checked.

11.3.4.4.6 AC voltage control

If relevant, the joint operation of the AC voltage control and active power control at the different converters is checked. The stability by step response in the power and voltage references, or during system disturbances such as capacitor bank or line switching is checked.

11.3.4.4.7 Load test

Ramp up to full power transmission or MVA converter rating is done for the different operating modes, as permitted by AC system and other conditions.

11.3.4.4.8 Measurements

Selected measurements of AC and DC harmonics and AC voltage distortion are taken.

NOTE Final measurements are usually reserved for acceptance tests.

11.3.4.4.9 Redundancy checks

If the system is equipped with redundant control and protection systems, transfers from the active to standby system are performed. Transfers between redundant auxiliary systems ~~should~~ need also to be checked during operation, for example auxiliary power, cooling pumps.

11.3.4.4.10 Remote control

Operation is tested from remote locations. All remote indications and control functions are checked.

NOTE Much of this work is done beforehand during subsystem testing, but this is the first time that remote system operators have direct control of the system. Previously, operation was from the local level with authorization only from the system operator.

11.3.4.4.11 Disturbance tests

In addition to testing the step responses to regulator references, the converter and its controls ~~should be~~ are tested again for various external disturbances in the AC transmission system to verify proper performance, stability and robustness. External disturbances can consist of switching nearby capacitor banks, transformers, transmission lines, tripping generators, or even staged faults, for example DC or AC overhead line faults, as relevant.

11.3.4.5 Trial operation

Trial operation allows the owner to operate the integrated system according to its intended purpose from the normal control location. Trial operation does not start until almost all system tests have been successfully completed. During trial operation, observation of the complete system and subsystems takes place. All alarms or abnormal conditions are dealt with as required.

11.3.4.6 Acceptance tests

11.3.4.6.1 General

Acceptance tests verify the performance of the system according to the specification on a selected basis. Acceptance tests ~~may~~ can involve measurements to verify that interference levels are within the design limits and that other fundamental performance criteria are met.

11.3.4.6.2 Heat run

The system is operated at rated and overload capacity for specified periods of time in different operating modes, if applicable. Temperatures and cooling systems are monitored. This test usually takes several hours due to the slow heating of the transformers.

11.3.4.6.3 Interference measurements

It is verified that harmonics on the AC and DC sides, audible noise, radio interference, PLC interference, etc., meet the performance requirements.

11.3.4.6.4 Disturbance response

Auxiliary supply changeover, control system changeover, line switching, shunt bank switching, generator tripping or staged faults are tested, as necessary.

Annex A (informative)

Functional specification requirements for VSC transmission systems

A.1 Introduction General

Annex A presents the minimum requirements of a functional specification for a VSC transmission system. Once the technical requirements of the VSC transmission system have been defined and confirmed by basic system studies, a functional specification can be prepared. Supplemented by the commercial conditions, the specification allows the purchaser to invite tenders from manufacturers for the equipment required. The functional specification ~~shall~~ needs to provide adequate information from the purchaser to the manufacturer and the required information exchange between the purchaser, the manufacturers and relevant subcontractors.

The specification ~~should include~~ usually includes parts where a minimum requirement is specified, as well as those parts where a performance above the minimum standard is desired but not essential. The specification ~~should include~~ includes a method for evaluating the above-minimum performance criteria.

In Clause A.2, the minimum technical information that needs to be provided by the purchaser and manufacturer are summarized. These summaries describe:

- general requirements of the VSC transmission system;
- power system configuration to which the VSC transmission system is connected, including all the parallel transmission systems, if any;
- requirements of the DC line, i.e., type of cable or overhead line or combination thereof. If the DC line is not within the scope of supply, the converter manufacturer ~~should~~ needs to provide information that would be needed for a proper line specification. The type of line chosen ~~should be~~ is approved by the converter manufacturer as to its applicability;
- site and environment;
- operating function of the VSC;
- maintenance, performance tests and spare parts requirements;
- VSC site, transmission right of way, and environmental constraints and consideration;
- factory and commissioning tests;
- other considerations relating to loss evaluation, tender evaluation, health and safety, and other ancillary requirements.

The purchaser ~~shall provide~~ usually provides a detailed description of the power systems connected to the VSC transmission system to enable the suppliers to offer the most suitable and economic equipment design. In addition, the purchaser and the manufacturer ~~shall~~ usually maintain a continuous dialogue starting at the tender stage and continuing until the project is completed. ~~It is recommended that~~ The manufacturer ~~should review~~ reviews the basic studies undertaken by the purchaser, and vice versa.

A.2 Purchaser and manufacturer information requirements

A.2.1 General

In A.2.2 and A.2.3, information marked with an asterisk (*) ~~may~~ can require detailed studies that ~~may~~ might not be available before the contract stage. All information in A.2.2 and A.2.3 not marked with an asterisk (*) is normally provided at the tender stage.

For some parameters, time varying data ~~may~~ can be appropriate, for example the range of AC system RMS voltage ~~may~~ can include excursions outside a normal range during brief periods (hours, minutes, seconds or milliseconds) with different limits for each duration. Such time varying data ~~shall~~ need to be described in an appropriate manner.

The confirmation of performance ~~may~~ can be demonstrated by any one or a combination of the following methods:

- studies;
- computer simulation;
- tests.

A.2.2 General requirements

Purchaser specification requirement	VSC manufacturer supplied information
Definition of scope of supply	
Location of the VSC	
Role of the VSC	General description of solution
Converter type and DC side configurations (if fixed) <ul style="list-style-type: none"> • Converter type • Topology of DC system • Type of DC line/cable • Transmission voltage (if fixed) 	Confirmation of the VSC type and configuration and DC side configurations
Main ratings of the VSC <ul style="list-style-type: none"> • Power to be transmitted • Locations of real and reactive power reference points • DC voltage and current, if applicable • AC sending and receiving voltages • Frequency of the system • Power resolution 	Guaranteed rating of the VSC
Important ancillary control requirements, e.g., <ul style="list-style-type: none"> • Reactive power regulation requirements • Overload requirements • Transient performance 	Guaranteed performance of the VSC
Requirement on VSC losses <ul style="list-style-type: none"> • Definition of operating point(s) for which losses are to be determined • Capitalized loss evaluation rate 	Losses at designated operating conditions and the method of loss calculation and loss distribution between the major components
Standards and codes	Confirmation of the standards and codes
In service date	<ul style="list-style-type: none"> • Confirmation of the critical dates • Key milestone dates
Tender assessment criteria	
Special premiums applied, e.g., for performance in excess of the minimum requirement	Details of the areas where the minimum required performance is exceeded
Health and safety requirements	

A.2.3 Detailed descriptions

A.2.3.1 Power system configurations

A.2.3.1.1 General

Purchaser specification requirement	VSC manufacturer supplied information
System configuration <ul style="list-style-type: none"> • Single line diagram of the system connection points • Harmonic impedance envelopes seen from the points of connection • Data on nearby generation • Modelling information for nearby controllable devices, such as static VAR (volt-ampere reactive) compensators (SVCs), wind turbines, etc. 	

A.2.3.1.2 DC line/cable (in case of turnkey, supplied by the converter manufacturer)

Purchaser specification requirement	Converter manufacturer supplied information
Main features of DC side <ul style="list-style-type: none"> • Configuration of the DC system • Topology of DC system • Type of DC transmission line (cable or overhead line or a combination thereof) • Length of the overhead line • Length of the cable 	Confirmation of the configuration of the DC system including cable/ overhead line parameters, e.g., <ul style="list-style-type: none"> • current capability, steady state and overload (if any) • voltage withstand capability • proposed type tests including test levels
National safety codes/standards for design of overhead lines and cables	Confirmation of the national safety codes/standards Confirm that design meets the requirements
Information about the overhead line <ul style="list-style-type: none"> • Air temperature range • Wind conditions • Ice loading requirements • Air pollution level • Risk of vandalism 	Confirm that design meets the criteria*
Information about the cable <ul style="list-style-type: none"> • Length of cable • Minimum required depth of burial • Survey data about the subsea/land terrain • Thermal resistivity of soil/silt/seabed • Temperature conditions • Requirement for fibre optic cable (whether embedded or not) 	Confirm that design meets the criteria*
Location of nearby communication cables	Confirm there is no effect on communication cables*

A.2.3.1.3 DC line/cable (not supplied by the converter manufacturer)

Since the design of the converter and the cable are interdependent, the design process will be iterative. Therefore, the data needs to flow between the VSC manufacturer and the cable supplier as shown below.

Purchaser specification requirement	Converter manufacturer supplied information
Provide data from the DC line/cable supplier to the converter manufacturer	<ul style="list-style-type: none"> • Maximum steady-state, dynamic and transient current by the VSC • Maximum steady-state, dynamic and transient voltage by the VSC • Harmonic voltage and current at the VSC terminals caused by the VSC • Overvoltage protection provided • Approval of selected DC line/cable system
Requirement for VSC data for cable manufacturer	Data provided

A.2.3.2 Site and environment

Purchaser specification requirements	Manufacturer supplied information
Space and footprint restrictions	VSC layout and layout options
Site accesses and transports limitations	Access and transport requirements
Electromagnetic field limitations	Electromagnetic field generation
Electromagnetic immunity requirements	Electromagnetic immunity levels*
Requirement for VSC grounding conditions	Requirement of appropriate electrode
Ambient temperature, pressure and humidity ranges	Confirm operation under required conditions*
Solar, snow and ice, wind, air pollution, isokeraunic level and seismic conditions	Confirm operation under required conditions*
Noise restriction, acoustic and electromagnetic telephone interference restrictions	Confirmation of the requirement*
Requirements in respect of earthquake resistance	Confirmation that the design meets the requirement with respect to earthquake resistance*

A.2.3.3 Operating function of the VSC

Purchaser specification requirement	Manufacturer supplied information
Requirement for the main operation <ul style="list-style-type: none"> • Requirement for the transmitted power • Main ancillary operation (if needed) <ul style="list-style-type: none"> – Requirement for the reactive power – Requirement for the AC voltage regulation – Requirement for the DC voltage regulation – Requirement for the control priorities 	Confirm operation ability* including the VSC control modes and control laws
Requirement for the dynamic performance <ul style="list-style-type: none"> • Requirement for the response time for the output change • Requirement for the overload performance 	Confirm operation ability* including short-term overload ratings

Purchaser specification requirement	Manufacturer supplied information
<p>Operation range (Range of conditions over which rated performance or ride-through is required)</p> <ul style="list-style-type: none"> • Range of the AC system conditions in which the VSC has needs to operate (both steady state and transient) <ul style="list-style-type: none"> – AC sending and receiving voltage range including temporary overvoltage – AC frequency range – Range of AC voltage imbalance – Zero sequence voltage range – Range of harmonics – Switching transient – Fault level – System configuration • DC conditions 	<p>Confirmation that the system remains operational and description of the performance*</p>
<p>Requirement for protection</p> <ul style="list-style-type: none"> • Faults which shall be are postulated for the VSC to be turned off safely or to ride-through <ul style="list-style-type: none"> – Fault types – Faults levels and clearance times – Whether single- or three-phase auto-reclosure is used and if so, the timing of different periods. • Protection for the AC system • Protection for the DC side • Protection for the VSC 	<p>Confirmation of the requirement, e.g.,</p> <ul style="list-style-type: none"> • performance during faults, other low-voltage conditions and switching transients • control logic and settings for operation during above conditions • description of protection system, including protection against internal failures • worst case internal faults in terms of duration and effect on transmission
<p>Acceptable adverse effect to the power system by the VSC</p> <ul style="list-style-type: none"> • Harmonics • Electromagnetic noise 	<ul style="list-style-type: none"> • Predicted value of harmonics (voltage and current) generated from the VSC • Measured value* of harmonics (voltage and current) generated from the VSC • Individual harmonic distortion D_n^* • Total harmonic distortion THD* • Telephone influence factor TIF*
<p>Requirement for the insulation coordination</p>	<p>Overvoltage withstand capability *</p>
<p>Others</p> <ul style="list-style-type: none"> • Requirement for earthquake resistance • Requirement for salt damage • Reliability <ul style="list-style-type: none"> – Requirement for the lifetime of the VSC – Requirement for the availability – Requirement for the outage rate – Prerequisite condition for the reliability design – Requirement for redundancy • Requirement for the measurements, alarm, and monitoring • Requirement for the interface between the power system and the VSC <ul style="list-style-type: none"> – Main circuit – Control signal • Initial energization and shutdown requirement 	<p>Confirmation of the requirement*, e.g.,</p> <ul style="list-style-type: none"> • Predicted life, reliability and availability characteristics, forced outage rates, maintenance frequency and periods • Failure rate of key components, e.g., semiconductors, DC capacitors • Transient effect of component failure

A.2.3.4 Maintenance and spares

Purchaser specification requirement	Manufacturer supplied information
Maintenance requirement	Maintenance frequency, duration and recommended maintenance
Special maintenance test equipment requirements	Special test equipment provided
Spares requirements	Recommended spares holdings
Drawings, maintenance manuals, technical notes	Description of documentation provided As-built drawings, maintenance manuals and technical notes provided*

A.2.3.5 Factory and commissioning tests

Purchaser specification requirements	Manufacturer supplied information
Test requirements <ul style="list-style-type: none"> • Equipment requiring type test approval • Factory tests • Functional testing of control suites 	Confirmation of the requirement, e.g., <ul style="list-style-type: none"> • type test evidence offered in lieu of new type tests • test schedules
Test standards	Confirmation to perform tests as per specified standard
Commissioning tests and schedule	Provide list of proposed commissioning tests and testing schedule

A.2.3.6 Auxiliary systems

Purchaser specification requirements	Manufacturer supplied information
Auxiliary power and cooling facility prepared by the purchaser side	Auxiliary power facility required and system description Method of initial energizing, restart and shutdown
Requirement for the control facilities	Description of control facilities including remote and local man-machine interfaces, detailing control, alarm, communication and monitoring facilities*
Auxiliary systems on main equipment	
Fire safety requirements	<ul style="list-style-type: none"> • Description of materials used* • Description of means of protecting against fire* • Fire containment methods*

~~All information not marked with an Asterisk (*) is normally provided at the tender stage.~~

Annex B (informative)

Modulation strategies for 2-level converters

B.1 Carrier wave PWM

Figure B.1 a) shows the control signals (the carriers and the voltage references as sine wave) for a PWM VSC. Figure B.1 b) shows the resulting voltage V_{am} at the AC terminal a, with respect to a hypothetical midpoint m of the DC capacitor. In this example, the frequency of the carrier (triangular wave signal) is nine times the fundamental frequency.

The general harmonic form of the switched waveform of ~~Figure 29~~ Figure B.1 b) can be written as:

$$v_{am}(t) = \frac{U_d}{2} M \cos(\omega_1 t + \theta_1) + \sum_{m=1}^{\infty} \sum_{n=-\infty}^{\infty} C_{mn} \cos[m(\omega_c t + \theta_c) + n(\omega_1 t + \theta_1)]$$

where

M is the modulation index;

ω_1 is the fundamental frequency;

ω_c is the carrier frequency;

m is a multiple of the carrier frequency;

n is a multiple of the fundamental frequency;

θ_1 is an arbitrary phase offset of the fundamental waveform;

θ_c is an arbitrary phase offset of the carrier waveform.

The most effective approach to determine the harmonic coefficients C_{mn} is using double integral Fourier form as:

$$C_{mn} = \frac{1}{2\pi^2} \int_{-\pi}^{\pi} \int_{-\pi}^{\pi} F(x, y) e^{j(mx+ny)} dx dy$$

where

$F(x, y)$ is the switched waveform for one fundamental cycle;

$x = \omega_c t$;

$y = \omega_1 t$.

The general harmonic form of the switched waveform defines carrier multiple harmonics (when $m \neq 0$ and $n = 0$) and sideband harmonics around the carrier multiples (when $m \neq 0$ and $n \neq 0$). Figure B.1 shows the typical harmonic spectra of the voltage waveforms for phase-to-floating neutral and phase-to-phase, respectively, for a 2-level VSC using PWM switched waveforms with a carrier-based control method using 21 times fundamental frequency and assuming infinite DC capacitance (i.e. no DC voltage ripple). These harmonic spectra would be changed under different specific operating conditions.

For a three-phase 2-level VSC, a balanced set of three-phase line-line output voltages is obtained if the phase leg references are displaced by 120° . In this case, the triplen sideband harmonics around each carrier multiple are cancelled in the line-line output voltages. It is important to note that the harmonic cancellation is a consequence of the triplen sideband harmonics. The carrier/fundamental ratio has no influence, and it can be odd, even or not integer.

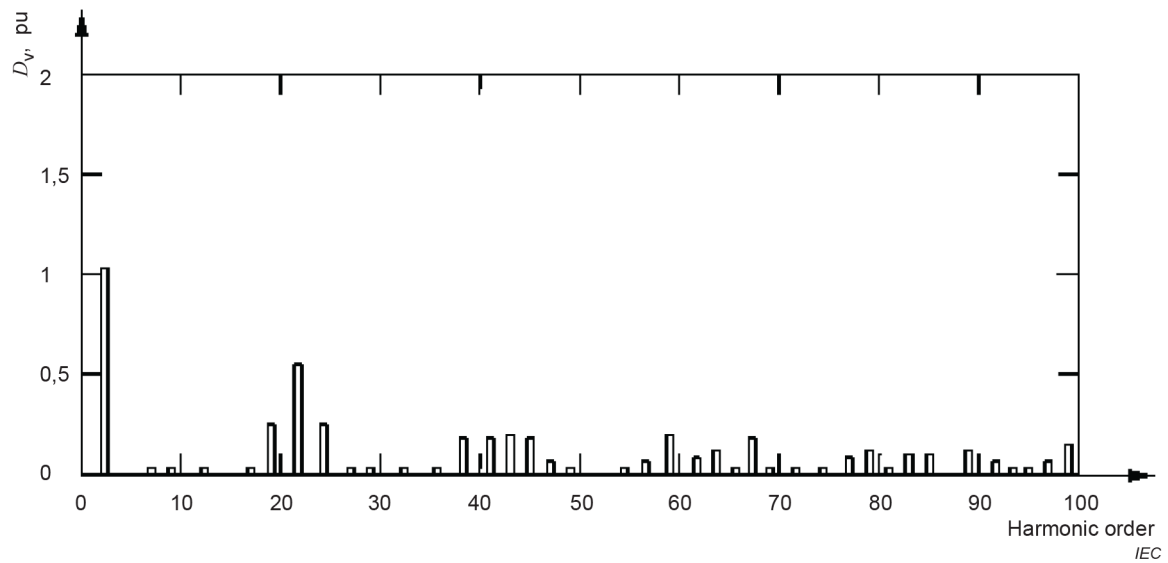

a) Phase-to-floating neutral voltage amplitude versus harmonic order

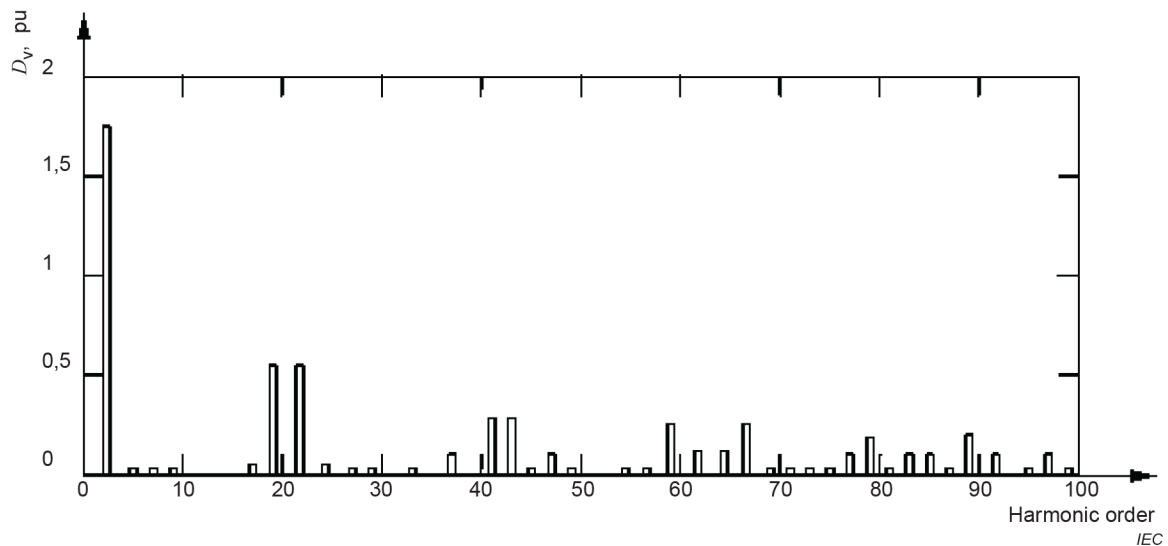

b) Phase-to-phase voltage amplitude versus harmonic order

Figure B.1 – Voltage harmonics spectra of a 2-level VSC with carrier frequency at 21st harmonic

B.2 Selective harmonic elimination modulation

Selective harmonic elimination modulation (SHEM) is known as a modulation method to eliminate the undesirable low order harmonics. SHEM approach is an effective way to eliminate the selected most significant harmonics using lower switching frequency. Figure B.2 shows the waveform switched at predetermined angles. The switched waveform has odd half-wave symmetry and even quarter-wave symmetry. The K switching angles can be used to eliminate $K - 1$ significant harmonic component and control the fundamental voltage.

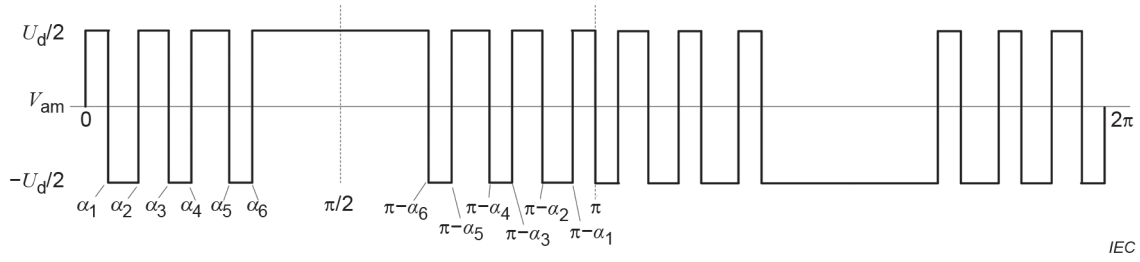

Figure B.2 – Phase output voltage for selective harmonic elimination modulation (SHEM)

The general Fourier series of the switched waveforms shown in Figure B.2 can be given as

$$v_{am}(t) = \sum_{n=1}^{\infty} (a_n \cos n\omega t + b_n \sin n\omega t)$$

For a waveform with quarter-wave symmetry, only the odd harmonics with sine component will be present. Therefore,

$$a_n = 0$$

$$b_n = \frac{4}{n\pi} \left[1 + 2 \sum_{k=1}^K (-1)^k \cos n\alpha_k \right]$$

Note that K number of simultaneous equations are required to solve the K number of switching angles. The fundamental voltage can be controlled using one equation, and $K - 1$ harmonics can be eliminated using the other $K - 1$ equations. Usually, the lowest significant harmonics are to be eliminated. For a three-phase three-wire 2-level VSC, the triplen harmonics can be ignored if the phase references are displaced by 120° .

Bibliography

- [1] CIGRE Technical Brochure No. 492, *Voltage Source Converter (VSC) HVDC for Power Transmission – Economic Aspects and Comparison with other AC and DC Technologies*
 - [2] CIGRE Technical Brochure No. 269, *VSC Transmission*
 - [3] CIGRE Technical Brochure No. 447, *Component Testing of VSC System for HVDC Applications*
 - [4] IEC TR 62001-1, *High-voltage direct current (HVDC) systems – Guidance to the specification and design evaluation of AC filters – Part 1: Overview*
 - [5] CIGRE Technical Brochure No. 811, *DC side harmonics and filtering in HVDC transmission systems*, 2020
 - [6] CIGRE Technical Brochure No. 370, *Integration of large scale wind generation using HVDC & power electronics*
 - [7] IEC 61803, *Determination of power losses in high-voltage direct current (HVDC) converter stations with line-commutated converters*
 - [8] IEC 62751 (all parts), *Power losses in voltage sourced converter (VSC) valves for high-voltage direct current (HVDC) systems*
 - [9] IEC 62751-1, *Power losses in voltage sourced converter (VSC) valves for high-voltage direct current (HVDC) systems – Part 1: General requirements*
 - [10] IEC 62751-2, *Power losses in voltage sourced converter (VSC) valves for high-voltage direct current (HVDC) systems – Part 2: Modular multilevel converters*
 - [11] IEC TR 62001-5, *High-voltage direct current (HVDC) systems – Guidance to the specification and design evaluation of AC filters – Part 5: AC side harmonics and appropriate harmonic limits for HVDC systems with voltage sourced converters (VSC)*
 - [12] IEC TR 62001 (all parts), *High-voltage direct current (HVDC) systems – Guidance to the specification and design evaluation of AC filters*
 - [13] IEC TS 61973, *High voltage direct current (HVDC) substation audible noise*
 - [14] IEC 61000 (all parts), *Electromagnetic compatibility (EMC)*
 - [15] CIGRE Technical Brochure No. 697, *Commissioning of VSC HVDC schemes*
 - [16] IEC 62501, *Voltage sourced converter (VSC) valves for high-voltage direct current (HVDC) power transmission – Electrical testing*
-

TECHNICAL REPORT



High-voltage direct current (HVDC) power transmission using voltage sourced converters (VSC)



CONTENTS

FOREWORD	6
1 Scope	8
2 Normative references	8
3 Terms and definitions	8
3.1 General.....	8
3.2 Letter symbols	10
3.3 VSC transmission	10
3.4 Power losses	11
4 VSC transmission overview	11
4.1 Basic operating principles of VSC transmission.....	11
4.1.1 Voltage sourced converter as a black box.....	11
4.1.2 Principles of active and reactive power control	12
4.1.3 Operating principles of a VSC transmission scheme	14
4.1.4 Applications of VSC transmission	15
4.2 Design life.....	15
4.3 VSC transmission configurations.....	15
4.3.1 General	15
4.3.2 DC circuit configurations.....	16
4.3.3 Monopole configuration	16
4.3.4 Bipolar configuration.....	17
4.3.5 Parallel connection of two converters	18
4.3.6 Series connection of two converters	19
4.3.7 Parallel and series connection of more than two converters	19
4.4 Semiconductors for VSC transmission	19
5 VSC transmission converter topologies.....	21
5.1 General.....	21
5.2 Converter topologies with VSC valves of switch type	21
5.2.1 General	21
5.2.2 Operating principle	22
5.2.3 Topologies.....	22
5.3 Converter topologies with VSC valves of the controllable voltage source type.....	25
5.3.1 General	25
5.3.2 MMC topology with VSC levels in half-bridge topology.....	26
5.3.3 MMC topology with VSC levels in full-bridge topology.....	28
5.3.4 CTL topology with VSC cells in half-bridge topology	28
5.3.5 CTL topology with VSC cells in full-bridge topology	28
5.4 VSC valve design considerations	29
5.4.1 Reliability and failure mode.....	29
5.4.2 Current rating	29
5.4.3 Transient current and voltage requirements	29
5.4.4 Diode requirements	30
5.4.5 Additional design details.....	30
5.5 Other converter topologies.....	31
5.6 Other equipment for VSC transmission schemes.....	31
5.6.1 General	31
5.6.2 Power components of a VSC transmission scheme.....	31

5.6.3	VSC substation circuit breaker.....	32
5.6.4	AC system side harmonic filters.....	32
5.6.5	Radio frequency interference filters.....	32
5.6.6	Interface transformers and phase reactors.....	32
5.6.7	Valve reactor.....	33
5.6.8	DC capacitors.....	33
5.6.9	DC reactor.....	35
5.6.10	DC filter.....	36
5.6.11	Dynamic braking system.....	36
6	Overview of VSC controls.....	36
6.1	General.....	36
6.2	Operational modes and operational options.....	37
6.3	Power transfer.....	38
6.3.1	General.....	38
6.3.2	Telecommunication between converter stations.....	38
6.4	Reactive power and AC voltage control.....	38
6.4.1	AC voltage control.....	38
6.4.2	Reactive power control.....	39
6.5	Black start capability.....	39
6.6	Supply from a wind farm.....	39
7	Steady-state operation.....	40
7.1	Steady-state capability.....	40
7.2	Converter power losses.....	41
8	Dynamic performance.....	42
8.1	AC system disturbances.....	42
8.2	DC system disturbances.....	42
8.2.1	DC cable fault.....	42
8.2.2	DC overhead line fault.....	43
8.3	Internal faults.....	43
9	HVDC performance requirements.....	44
9.1	Harmonic performance.....	44
9.2	Wave distortion.....	45
9.3	Fundamental and harmonics.....	45
9.3.1	Three-phase 2-level VSC.....	45
9.3.2	Multi-pulse and multi-level converters.....	45
9.4	Harmonic voltages on power systems due to VSC operation.....	46
9.5	Design considerations for harmonic filters (AC side).....	46
9.6	DC side filtering.....	46
10	Environmental impact.....	47
10.1	General.....	47
10.2	Audible noise.....	47
10.3	Electric and magnetic fields (EMF).....	47
10.4	Electromagnetic compatibility (EMC).....	47
11	Testing and commissioning.....	48
11.1	General.....	48
11.2	Factory tests.....	49
11.2.1	Component tests.....	49
11.2.2	Control system tests.....	49

11.3	Commissioning tests/system tests.....	49
11.3.1	General	49
11.3.2	Precommissioning tests	50
11.3.3	Subsystem tests	50
11.3.4	System tests.....	50
Annex A (informative)	Functional specification requirements for VSC transmission systems	55
A.1	General.....	55
A.2	Purchaser and manufacturer information requirements	55
A.2.1	General	55
A.2.2	General requirements	56
A.2.3	Detailed descriptions	57
Annex B (informative)	Modulation strategies for 2-level converters	61
B.1	Carrier wave PWM.....	61
B.2	Selective harmonic elimination modulation.....	62
Bibliography.....		64
Figure 1 – Major components that can be found in a VSC substation		9
Figure 2 – Diagram of a generic voltage source converter.....		12
Figure 3 – Principle of active power control.....		13
Figure 4 – Principle of reactive power control		14
Figure 5 – A point-to-point VSC transmission scheme.....		14
Figure 6 – VSC transmission with a symmetrical monopole.....		16
Figure 7 – VSC transmission with an asymmetrical monopole with metallic return.....		17
Figure 8 – VSC transmission with an asymmetrical monopole with earth return.....		17
Figure 9 – VSC transmission in bipolar configuration with earth return.....		17
Figure 10 – VSC transmission in bipolar configuration with dedicated metallic return		18
Figure 11 – VSC transmission in rigid bipolar configuration.....		18
Figure 12 – Parallel connection of two converter units		19
Figure 13 – Symbol of a turn-off semiconductor device and associated free-wheeling diode		20
Figure 14 – Symbol of an IGBT and associated free-wheeling diode		20
Figure 15 – Diagram of a three-phase 2-level converter and associated AC waveform for one phase.....		23
Figure 16 – Single-phase AC output for 2-level converter with PWM switching at 21 times fundamental frequency		23
Figure 17 – Diagram of a three-phase 3-level NPC converter and associated AC waveform for one phase.....		24
Figure 18 – Single-phase AC output for 3-level NPC converter with PWM switching at 21 times fundamental frequency		25
Figure 19 – Electrical equivalent for a converter with VSC valves acting like a controllable voltage source		26
Figure 20 – VSC valve level arrangement and equivalent circuit in MMC topology in half-bridge topology		27
Figure 21 – Converter block arrangement with MMC topology in half-bridge topology		27
Figure 22 – VSC valve level arrangement and equivalent circuit in MMC topology with full-bridge topology		28

Figure 23 – Typical SSOA for the IGBT 29

Figure 24 – A 2-level VSC bridge with the IGBTs turned off 30

Figure 25 – Representing a VSC unit as an AC voltage of magnitude U and phase angle δ behind reactance 36

Figure 26 – Concept of vector control 37

Figure 27 – VSC power controller 38

Figure 28 – AC voltage controller 39

Figure 29 – A typical simplified PQ diagram 41

Figure 30 – Protection concept of a VSC substation 43

Figure 31 – Waveforms for three-phase 2-level VSC 45

Figure 32 – Equivalent circuit at the PCC of the VSC 46

Figure B.1 – Voltage harmonics spectra of a 2-level VSC with carrier frequency at 21st harmonic 62

Figure B.2 – Phase output voltage for selective harmonic elimination modulation (SHEM) 63

INTERNATIONAL ELECTROTECHNICAL COMMISSION

**HIGH-VOLTAGE DIRECT CURRENT (HVDC) POWER
TRANSMISSION USING VOLTAGE SOURCED CONVERTERS (VSC)**

FOREWORD

- 1) The International Electrotechnical Commission (IEC) is a worldwide organization for standardization comprising all national electrotechnical committees (IEC National Committees). The object of IEC is to promote international co-operation on all questions concerning standardization in the electrical and electronic fields. To this end and in addition to other activities, IEC publishes International Standards, Technical Specifications, Technical Reports, Publicly Available Specifications (PAS) and Guides (hereafter referred to as "IEC Publication(s)"). Their preparation is entrusted to technical committees; any IEC National Committee interested in the subject dealt with may participate in this preparatory work. International, governmental and non-governmental organizations liaising with the IEC also participate in this preparation. IEC collaborates closely with the International Organization for Standardization (ISO) in accordance with conditions determined by agreement between the two organizations.
- 2) The formal decisions or agreements of IEC on technical matters express, as nearly as possible, an international consensus of opinion on the relevant subjects since each technical committee has representation from all interested IEC National Committees.
- 3) IEC Publications have the form of recommendations for international use and are accepted by IEC National Committees in that sense. While all reasonable efforts are made to ensure that the technical content of IEC Publications is accurate, IEC cannot be held responsible for the way in which they are used or for any misinterpretation by any end user.
- 4) In order to promote international uniformity, IEC National Committees undertake to apply IEC Publications transparently to the maximum extent possible in their national and regional publications. Any divergence between any IEC Publication and the corresponding national or regional publication shall be clearly indicated in the latter.
- 5) IEC itself does not provide any attestation of conformity. Independent certification bodies provide conformity assessment services and, in some areas, access to IEC marks of conformity. IEC is not responsible for any services carried out by independent certification bodies.
- 6) All users should ensure that they have the latest edition of this publication.
- 7) No liability shall attach to IEC or its directors, employees, servants or agents including individual experts and members of its technical committees and IEC National Committees for any personal injury, property damage or other damage of any nature whatsoever, whether direct or indirect, or for costs (including legal fees) and expenses arising out of the publication, use of, or reliance upon, this IEC Publication or any other IEC Publications.
- 8) Attention is drawn to the Normative references cited in this publication. Use of the referenced publications is indispensable for the correct application of this publication.
- 9) Attention is drawn to the possibility that some of the elements of this IEC Publication may be the subject of patent rights. IEC shall not be held responsible for identifying any or all such patent rights.

IEC TR 62543 has been prepared by subcommittee 22F: Power electronics for electrical transmission and distribution systems, of IEC technical committee 22: Power electronic systems and equipment. It is a Technical Report.

This second edition cancels and replaces the first edition published in 2011, Amendment 1:2013 and Amendment 2:2017. This edition constitutes a technical revision.

This edition includes the following significant technical changes with respect to the previous edition:

- a) in Clause 3, some redundant definitions which were identical to those listed in IEC 62747 have been deleted;
- b) in 4.3.4, description and diagrams have been added for the cases of a bipole with dedicated metallic return and a rigid bipole;
- c) in 4.4, mention is made of the bi-mode insulated gate transistor (BiGT) and injection enhanced gate transistor (IEGT) as possible alternatives to the IGBT;

d) in 5.6, the reference to common-mode blocking reactors has been deleted since these are very rarely used nowadays.

The text of this Technical Report is based on the following documents:

Draft	Report on voting
22F/649/DTR	22F/669/RVDTR

Full information on the voting for its approval can be found in the report on voting indicated in the above table.

The language used for the development of this Technical Report is English.

This document was drafted in accordance with ISO/IEC Directives, Part 2, and developed in accordance with ISO/IEC Directives, Part 1 and ISO/IEC Directives, IEC Supplement, available at www.iec.ch/members_experts/refdocs. The main document types developed by IEC are described in greater detail at www.iec.ch/publications.

The committee has decided that the contents of this document will remain unchanged until the stability date indicated on the IEC website under webstore.iec.ch in the data related to the specific document. At this date, the document will be

- reconfirmed,
- withdrawn,
- replaced by a revised edition, or
- amended.

IMPORTANT – The "colour inside" logo on the cover page of this document indicates that it contains colours which are considered to be useful for the correct understanding of its contents. Users should therefore print this document using a colour printer.

HIGH-VOLTAGE DIRECT CURRENT (HVDC) POWER TRANSMISSION USING VOLTAGE SOURCED CONVERTERS (VSC)

1 Scope

This document gives general guidance on the subject of voltage sourced converters (VSC) used for transmission of power by high voltage direct current (HVDC). It describes converters that are not only voltage sourced (containing a capacitive energy storage medium and where the polarity of DC voltage remains fixed) but also self-commutated, using semiconductor devices which can both be turned on and turned off by control action. The scope includes 2-level and 3-level converters with pulse-width modulation (PWM), along with multi-level converters, modular multi-level converters and cascaded two-level converters, but excludes 2-level and 3-level converters operated without PWM, in square-wave output mode.

HVDC power transmission using voltage sourced converters is known as "VSC transmission".

The various types of circuit that can be used for VSC transmission are described in this document, along with their principal operational characteristics and typical applications. The overall aim is to provide a guide for purchasers to assist with the task of specifying a VSC transmission scheme.

Line-commutated and current-sourced converters are specifically excluded from this document.

2 Normative references

The following referenced documents are indispensable for the application of this document. For dated references, only the edition cited applies. For undated references, the latest edition of the referenced document (including any amendments) applies.

IEC 62501, *Voltage sourced converter (VSC) valves for high-voltage direct current (HVDC) power transmission – Electrical testing*

IEC 62747, *Terminology for voltage-sourced converters (VSC) for high-voltage direct current (HVDC) systems*

3 Terms and definitions

For the purposes of this document, the terms and definitions given in IEC 62747, IEC 62501 and the following apply.

ISO and IEC maintain terminological databases for use in standardization at the following addresses:

- IEC Electropedia: available at <http://www.electropedia.org/>
- ISO Online browsing platform: available at <http://www.iso.org/obp>

3.1 General

Basic terms and definitions for voltage sourced converters used for HVDC transmission are given in IEC 62747. Terminology on electrical testing of VSC valves for HVDC transmission is given in IEC 62501.

To support the explanations, Figure 1 presents the basic diagram of a VSC system. Dependent on the converter topology and the requirements in the project, some components can be omitted or can differ.

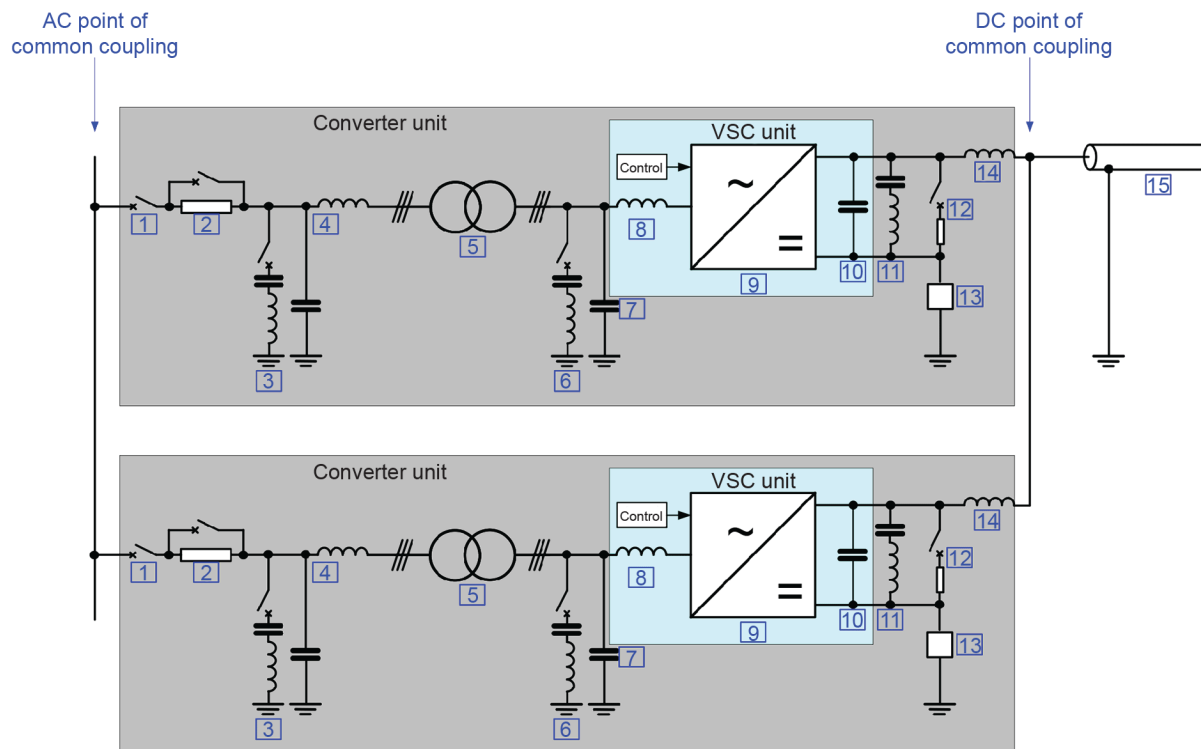

IEC

Key

1	circuit breaker	9	VSC unit ³⁾
2	pre-insertion resistor	10	VSC DC capacitor ⁴⁾
3	line side harmonic filter ¹⁾	11	DC harmonic filter ¹⁾
4	line side high frequency filter ⁶⁾	12	dynamic braking system ⁷⁾
5	interface transformer	13	neutral point grounding branch ⁵⁾
6	converter side harmonic filter ¹⁾	14	DC reactor ⁸⁾
7 + 8	converter side high frequency filter ²⁾	15	DC cable or overhead transmission line
8	phase reactor ²⁾		

1) In some designs of VSC based on controllable voltage source valves, it is possible the harmonic filter is not required.

2) In some designs of VSC, the phase reactor can fulfil part of the function of the converter-side high frequency filter.

3) In some VSC topologies, each valve of the VSC unit can include a "valve reactor", which can be built into the valve or provided as a separate component.

4) In some designs of VSC, the VSC DC capacitor can be partly or entirely distributed amongst the three-phase units of the VSC unit, where it is referred to as the DC submodule capacitors.

5) The philosophy and location of the neutral point grounding branch can be different depending on the design of the VSC unit.

6) In some designs of VSC, the interface transformer can fulfil part of the function of the line-side high frequency filter.

7) Optional.

8) Optional.

Figure 1 – Major components that can be found in a VSC substation

3.2 Letter symbols

U_{conv}	line-to-line AC voltage of the converter unit(s), RMS value, including harmonics
I_{conv}	alternating current of the converter unit(s), RMS value, including harmonics
U_{L}	line-to-line AC voltage of the AC system, RMS value, including harmonics
I_{L}	alternating current of the AC system, RMS value, including harmonic
U_{dc}	DC terminal-to-terminal voltage of one converter unit
I_{d}	DC current of the DC bus of the VSC transmission system

3.3 VSC transmission

3.3.1

VSC DC capacitor

capacitor bank(s) (if any) connected between two DC terminals of the VSC, used for energy storage and/or filtering purposes

3.3.2

AC side radio frequency interference filter

RFI filter

filters (if any) used to reduce penetration of radio frequency interference (RFI) into the AC system to an acceptable level

3.3.3

converter side high frequency filter

filters (if any) used to mitigate the HF stresses of the interface transformer

3.3.4

DC side radio frequency interference filter

filters (if any) used to reduce penetration of radio frequency (RF) into the DC system to acceptable limits

3.3.5

type tests

tests carried out to verify that the components of VSC transmission system design will meet the requirements specified

Note 1 to entry: In this document, type tests are classified under two major categories: dielectric tests and operational tests.

3.3.6

dielectric tests

tests carried out to verify the high voltage withstanding capability of the components of VSC transmission system

3.3.7

operational tests

tests carried out to verify the turn-on (if applicable), turn-off (if applicable), and current related capabilities of the components of VSC transmission system

3.3.8

production tests

tests carried out to verify proper manufacture, so that the properties of the certain component of VSC transmission system correspond to those specified

3.3.9

sample tests

production tests which are carried out on a small number of certain VSC transmission components, for example valve sections or special components taken at random from a batch

3.4 Power losses

3.4.1

auxiliary losses

electric power required to feed the VSC substation auxiliary loads

Note 1 to entry: The auxiliary losses depend on whether the substation is in no-load or carrying load, in which case the auxiliary losses depend on the load level.

3.4.2

no-load operating losses

losses produced in an item of equipment with the VSC substation energized but with the VSCs blocked and all substation service loads and auxiliary equipment connected as required for immediate pick-up of load

3.4.3

idling operating losses

losses produced in an item of equipment with the VSC substation energized and with the VSCs de-blocked but with no real or reactive power output

3.4.4

operating losses

losses produced in an item of equipment at a given load level with the VSC substation energized and the converters operating

3.4.5

total system losses

sum of all operating losses, including the corresponding auxiliary losses

3.4.6

station essential auxiliary load

loads whose failure will affect the conversion capability of the HVDC converter station (e.g. valve cooling), as well as the loads that need to remain working in case of complete loss of AC power supply (e.g. battery chargers, operating mechanisms)

Note 1 to entry: Total "operating losses" minus "no-load operating losses" can be considered as being quantitatively equivalent to "load losses" as in conventional AC substation practice.

4 VSC transmission overview

4.1 Basic operating principles of VSC transmission

4.1.1 Voltage sourced converter as a black box

The operation of a voltage sourced converter is described in greater detail in Clause 5. In 4.1, the converter is treated as a black box that can convert from AC to DC and vice versa, and only steady-state operation is considered.

Figure 2 depicts a schematic diagram of a generic voltage sourced converter connected to a DC circuit on one side and to an AC circuit on the other.

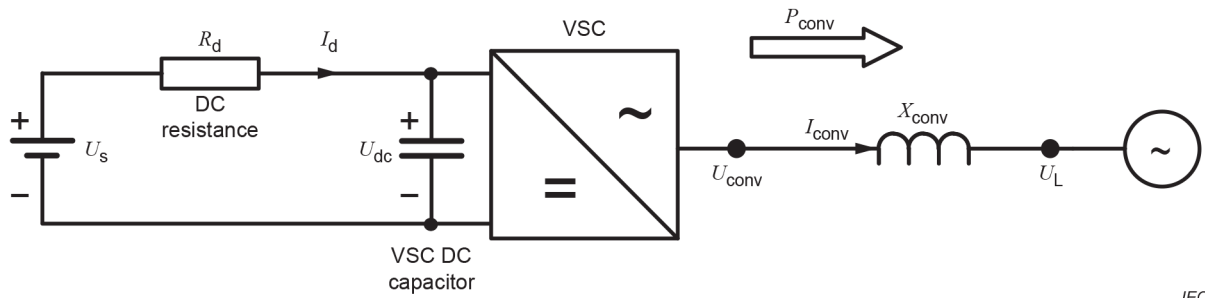

IEC

NOTE AC filters are not shown.

Figure 2 – Diagram of a generic voltage source converter

The VSC can be operated as either an inverter, injecting real power into the AC network ($I_d \times U_{dc} > 0$), or as a rectifier absorbing power from the AC network ($I_d \times U_{dc} < 0$). Similarly, the VSC can be operated either capacitively, injecting reactive power into the AC network ($\text{Im}(U_L \cdot I_L) > 0$), or inductively, absorbing reactive power from the AC network ($\text{Im}(U_L \cdot I_L) < 0$). The VSC can be operated capacitively or inductively in both the inverter and the rectifier mode.

The designation voltage sourced converter is used because the function of the VSC is predicated on the connection of a voltage source on the DC side.

To the left in Figure 2, a DC voltage source U_s is shown with a DC resistor R_d representing the DC circuit resistance, and a DC capacitor connected. The DC shunt capacitor serves the purpose of stabilizing the DC voltage U_d . Depending on the VSC converter topology, the DC storage capacitor is realized either as a central DC storage capacitor between both poles or as multiple storage capacitors distributed within the converter phase units. The conversion from DC to AC takes place in the VSC as explained in Clause 5.

On the AC side, an interface inductance X_{conv} is provided which serves two purposes: first, it stabilizes the AC current, and secondly, it controls active and reactive output power from the VSC, as explained in 4.1.2. The interface inductance can be implemented as reactors, as leakage inductances in transformers, or as a combination thereof. The DC capacitor on the input side and the AC interface inductance on the output side are important components for the proper functioning of a VSC.

A passive or active AC network can be connected on the AC side of the VSC. If the VSC is connected to a passive network on its AC side, the power flow can be only from the DC input side towards the passive load on the AC side. However, if the AC side is connected to an active AC network, the power flow can be in both directions by controlling the AC voltage output U_{conv} of the VSC.

By controlling the phase angle of U_{conv} , the active power through the VSC can be controlled as explained in 4.1.2.2. By controlling the voltage amplitude of U_{conv} , the reactive power through the VSC can be controlled as explained in 4.1.2.3.

4.1.2 Principles of active and reactive power control

4.1.2.1 General

The VSC can be considered as an equivalent of a synchronous generator without inertia, which has the capability of individually controlling active and reactive power.

The exchange of active and reactive power between a VSC and the AC grid is controlled by the phase angle and amplitude of the VSC output voltage in relation to the voltage of the AC grid.

The active and reactive power are related to the AC voltages U_L and U_{conv} of the AC system and converter respectively, the reactance X between these voltages and the phase angle δ between them, according to the following:

$$P = \frac{U_L \times U_{\text{conv}} \times \sin \delta}{X}$$

$$Q = \frac{U_L \times (U_L - U_{\text{conv}} \times \cos \delta)}{X}$$

If U_{conv} is in phase with the line voltage U_L and its amplitude is equal to U_L , there is no AC current I_{conv} from the VSC. Under these conditions, the DC current I_d becomes zero and the DC capacitor voltage U_{dc} becomes equal to the DC source voltage U_s .

4.1.2.2 Principle of active power control

The principle of active power control is depicted in Figure 3, where the active power through the interface inductance is controlled by regulating the VSC voltage angle.

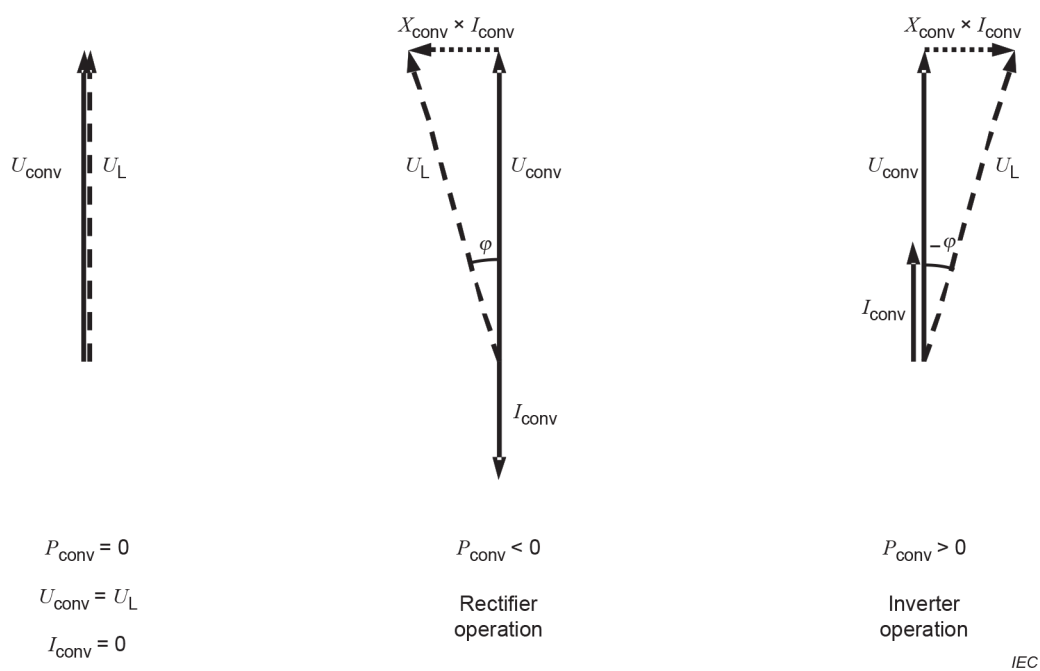

Figure 3 – Principle of active power control

If the angle of the VSC output voltage leads the AC grid voltage, the VSC will inject active power to the AC grid, i.e., it operates as an inverter. On the DC side, an equivalent current will be drawn from the DC source and the voltage U_{dc} will decrease in accordance with Ohm's law ($U_{\text{dc}} = U_s - R_d \cdot I_d$).

If, on the other hand, the VSC output voltage lags the voltage of the AC grid, the VSC will absorb active power from the AC grid, i.e., it operates as a rectifier. On the DC side, an equivalent current will be injected into the DC source and the voltage U_{dc} will increase in accordance with Ohm's law ($U_{\text{dc}} = U_s + R_d \cdot I_d$).

If the VSC is connected to a passive load, an AC output current will be drawn from the VSC determined by Ohm's law $I_{\text{conv}} = U_{\text{conv}}/Z$. Again, an equivalent DC current will be drawn from the source and the voltage U_{dc} on the DC capacitor will drop to a value determined by Ohm's law. No active power can be drawn from the AC side, because it is a passive AC circuit.

4.1.2.3 Principle of reactive power control

When active power $P = 0$ the principle of reactive power control is depicted in Figure 4, where the reactive power through the interface inductance is controlled by regulating the amplitude of the VSC output AC voltage.

If the amplitude of the VSC output voltage U_{conv} is higher than the AC grid voltage U_L , the VSC will inject reactive power in the AC grid, i.e., will operate in the capacitive mode. If the amplitude of the VSC output voltage is lower than the AC grid voltage, the VSC absorbs reactive power from the AC grid, i.e., the inductive operating mode.

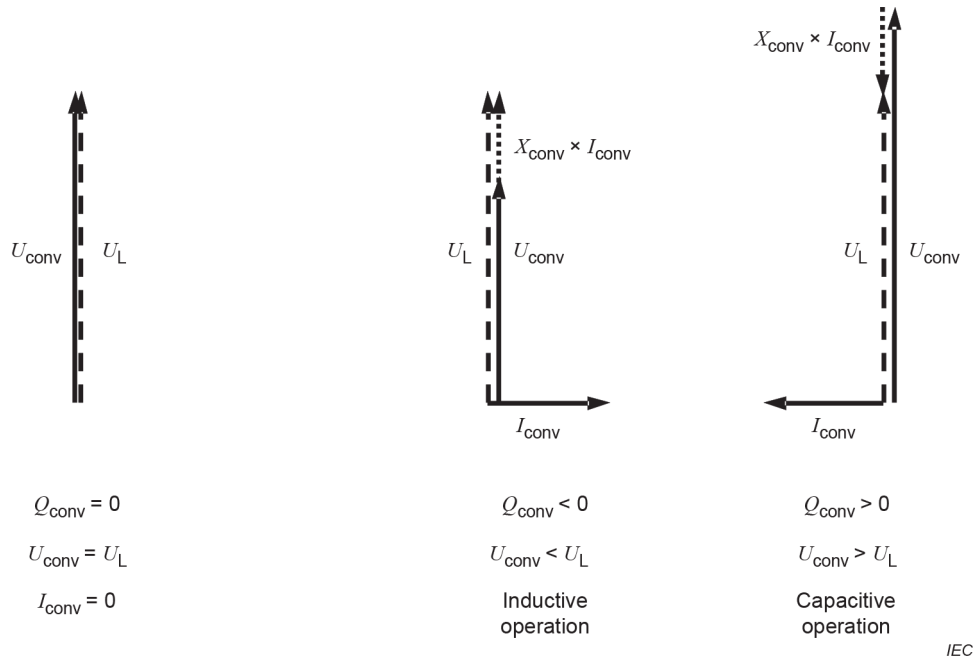

Figure 4 – Principle of reactive power control

4.1.3 Operating principles of a VSC transmission scheme

The point-to-point VSC transmission scheme shown in Figure 5 consists of two VSCs interconnected on the DC side via a DC transmission line and connected to two different AC grids on the AC side. The basic characteristics of a VSC have been described in 4.1.1 and 4.1.2. One of these characteristics is that the DC voltage polarity usually remains the same (in contrast with line-commutated converter (LCC) HVDC, where the polarity of DC voltage depends on the direction of power transfer). Therefore, the direction of the power flow on the DC line is usually determined by the direction of the DC current. In Figure 5, the current flow and the power flow are from VSC1 (the sending or rectifier end) to VSC2 (the receiving or inverter end) of the DC line.

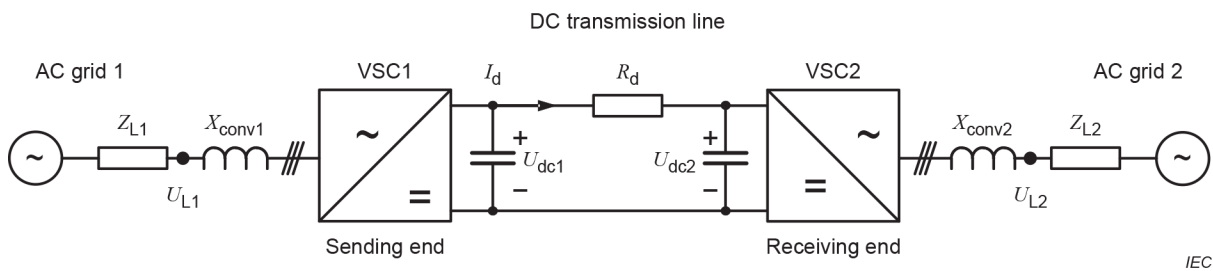

Figure 5 – A point-to-point VSC transmission scheme

The direction of a DC current is always from a higher DC voltage level to a lower DC voltage level. The DC voltage at the sending end of the DC line therefore needs to be higher than the DC voltage at the receiving end. The value of the current is determined by Ohm's law, as the voltage difference between sending and receiving ends divided by the resistance in the DC line $I_d = (U_{d1} - U_{d2})/R_d$.

For example, the DC line power flow can be controlled by holding the DC voltage at the receiving end converter (the inverter) at a constant value, and by letting the sending end converter (the rectifier) control the DC current.

4.1.4 Applications of VSC transmission

In general, the main fields of application of HVDC transmission are interconnection of asynchronous AC systems and long-distance transmission via overhead lines and cables. The following characteristic features of VSC transmission are decisive for different applications.

- The smaller amount of external equipment such as AC harmonic filters results in a compact design of VSC converter stations. Small footprints are beneficial for applications with spatial limitations such as installations in city centres or on remote offshore platforms.
- Since VSC transmission is based on self-commutating operation, applications with isolated and weak AC systems are feasible. During normal operation, the VSC provides voltage and frequency control of the AC system. Operation during AC faults is a major criterion for VSC. The ability of the VSC to inject fault currents facilitates AC system protection and fault clearing. Examples are connection of remote wind farms, oil and gas platforms and remote mines.
- In most cases, VSC transmission operates with a fixed DC voltage polarity. A reversal of direction of power flow requires the reversal of DC current. In case of parallel interconnection of AC systems via AC and DC lines, fast power reversals via DC current control provide an accurate measure for load flow stabilization between the AC systems. Since the polarity of DC voltage does not reverse, multi-terminal systems and HVDC grids are easier to realize with VSC than with LCC HVDC.

4.2 Design life

The selection of VSC transmission as an alternative to LCC HVDC, AC transmission, or local generation is normally motivated by financial, technical or environmental advantages. When evaluating different technologies, it is important to compare their life cycle costs.

The technical design life of transmission systems is normally very long – 30 years or more. An investment, however, needs only to last as long as it can provide the highest capital value, and this is designated the "optimal life". The optimal life will always be equal to or less than the technical design life.

4.3 VSC transmission configurations

4.3.1 General

With VSC transmission, there are several possibilities for the DC circuit and converter units.

Each VSC substation can be constructed from a single converter unit, resulting in a monopolar transmission scheme.

In some applications, it can be necessary or advantageous to combine several converter units each constructed using the same converter phase unit topology. For example, it might not be technically feasible or economically optimal to achieve the power, voltage or current rating with a single converter unit. Several converter units can be combined to achieve increased availability and limited power outage upon faults.

The combination of two or more converter units can be accomplished in a number of ways. The DC terminals of the converter units can be connected in parallel to achieve high output currents or in series to achieve high output voltages.

4.3.2 DC circuit configurations

Both cables and overhead transmission lines can be used for VSC transmission. However, there are several aspects associated with the basic principle of VSC transmission that can influence the choice.

- Since a VSC generally allows only one DC voltage polarity, the cable does not need to be designed for voltage polarity reversal. This allows the use of extruded cross-linked polyethylene (XLPE) DC cables. Faults on DC cables are considered as exceptional scenarios which result in a permanent fault of the affected section and an interruption of power transfer.
- Since overhead transmission lines are always exposed to lightning strikes and pollution, faults along them are likely. Most line outages are temporary and transmission recommences once the fault is cleared and the air insulation is restored.

A back-to-back configuration is a special case of VSC transmission where the DC transmission distance is zero.

4.3.3 Monopole configuration

4.3.3.1 General

The VSC converter can be operated in different monopolar configurations:

- symmetrical monopole;
- asymmetric monopole with metallic return;
- asymmetric monopole with earth return.

4.3.3.2 Symmetrical monopole

In a symmetrical monopole, the DC output voltages are of equal magnitude but opposite polarity. The neutral point t of the DC circuit is earthed, either by capacitors as shown in Figure 6 or by other means, for example a high-frequency earthing reactor on the AC side.

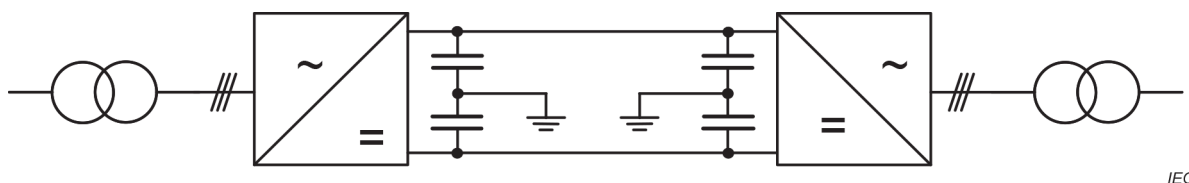

Figure 6 – VSC transmission with a symmetrical monopole

4.3.3.3 Asymmetrical monopole

In an asymmetrical monopole as shown on Figure 7 and Figure 8, the DC side output from the converter is asymmetrical with one side typically connected to earth. It is possible to operate the transmission system in metallic return or in earth return.

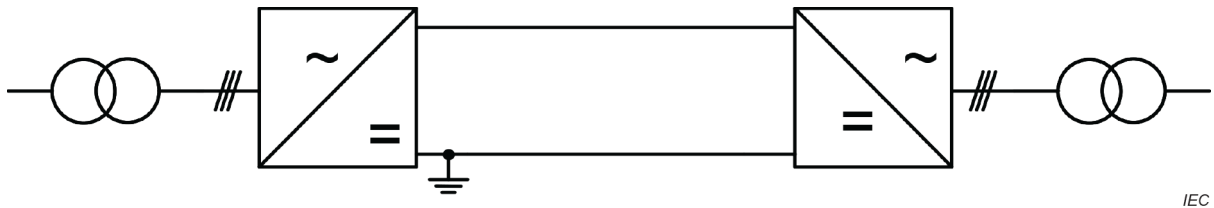

Figure 7 – VSC transmission with an asymmetrical monopole with metallic return



Figure 8 – VSC transmission with an asymmetrical monopole with earth return

4.3.4 Bipolar configuration

Two asymmetrical converters can be connected together in a bipolar configuration either with earth return (Figure 9) or dedicated metallic return (Figure 10).

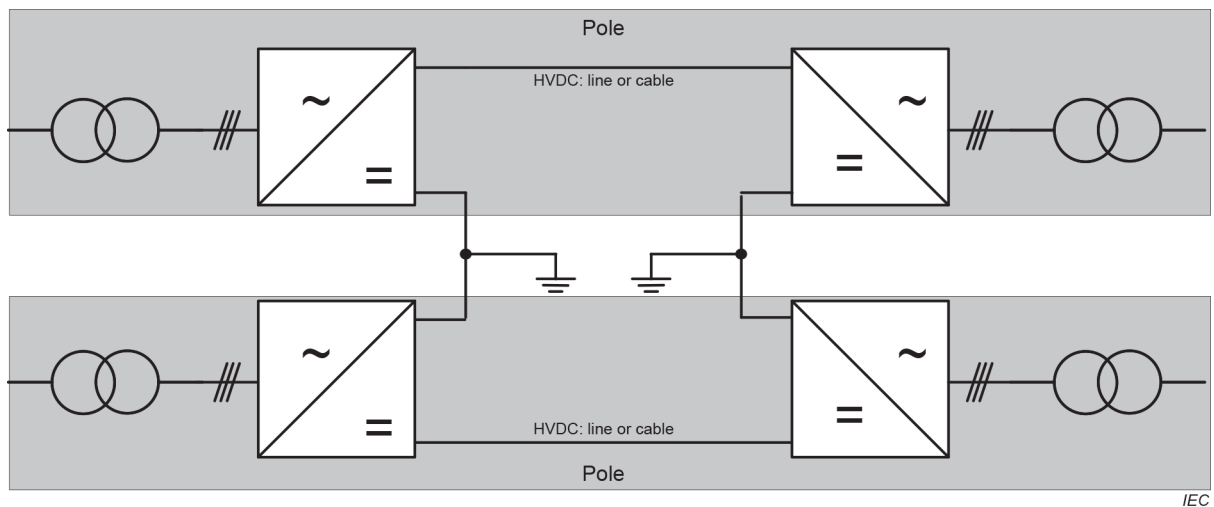

Figure 9 – VSC transmission in bipolar configuration with earth return

The neutral return bus can be designed by a similar process to that which is normally used for bipolar LCC HVDC schemes.

When there is an outage of a converter or DC line/cable, there is normally designed a possibility to operate the remaining system in asymmetrical monopole operation.

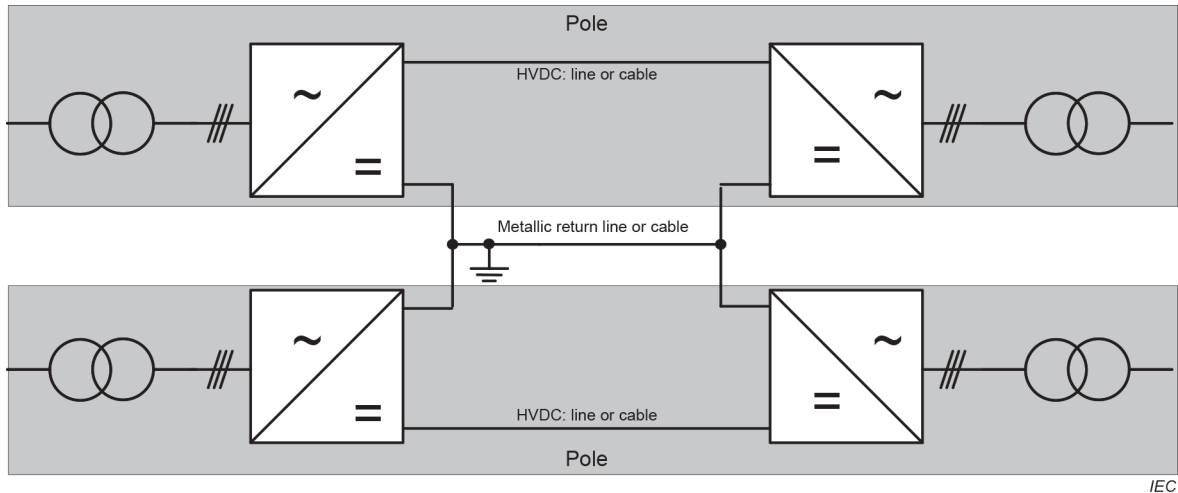

Figure 10 – VSC transmission in bipolar configuration with dedicated metallic return

A variant of the bipolar configuration, known as the rigid bipolar configuration (Figure 11), is also possible. In the rigid bipolar configuration, there is no neutral connection between the two converter stations. Bypass switchgear is provided in parallel with each converter unit such that, in the event of a fault in one converter unit, the system can still be operated with the remaining pole, using the pole conductor of the faulted pole as the neutral return. With the rigid bipolar configuration, power transmission on both poles is interrupted for a short time, while the bypass switchgear is operated, before resuming on the healthy pole.

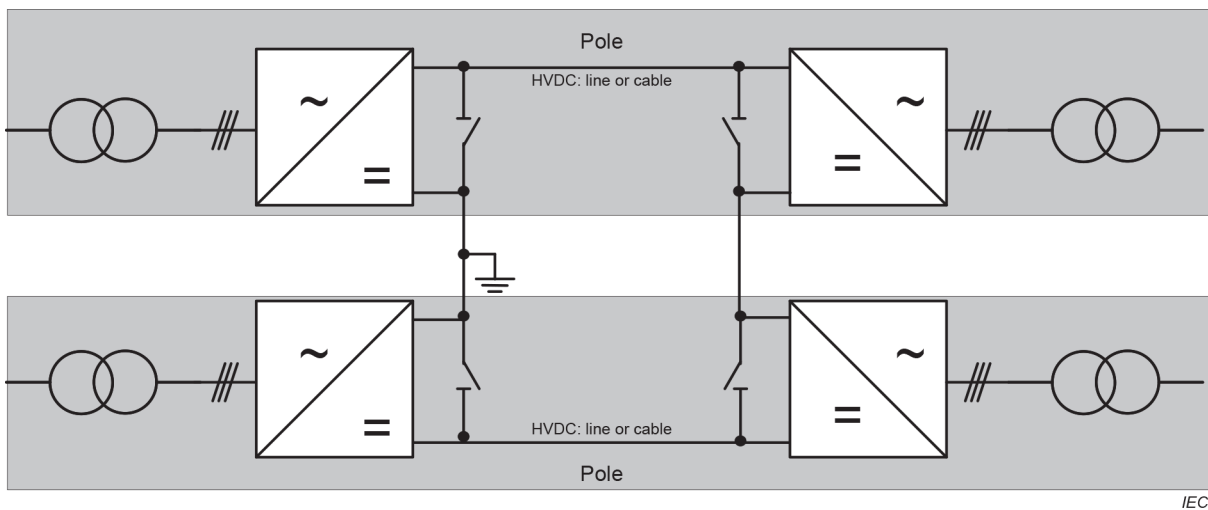

Figure 11 – VSC transmission in rigid bipolar configuration

4.3.5 Parallel connection of two converters

The DC terminals of two VSC converters can be connected in parallel resulting in high DC currents (Figure 12).

To prevent undesirable interaction between the two parallel-connected converters, some level of impedance could be provided between the two converters.

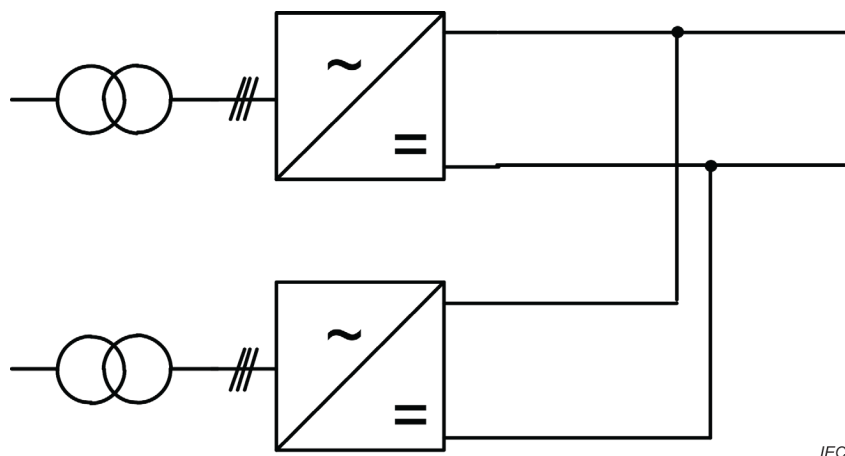

Figure 12 – Parallel connection of two converter units

Where parallel connection of converter units is chosen, a high level control is required in order to coordinate current orders between the converter units.

In order to achieve high reliability upon internal converter unit faults, additional switching and/or breaking devices are required to isolate a faulty converter unit. Obviously, the common DC transmission circuit has no redundancy upon DC line faults.

4.3.6 Series connection of two converters

Two VSC converters can be connected in series on their DC side. This approach can be used to extend the DC voltage capabilities of a VSC transmission relative to the capability of the individual converter units.

The technically most relevant scenario of series connection is the bipolar arrangement outlined in 4.3.4.

4.3.7 Parallel and series connection of more than two converters

In principle, it is also possible to connect more than two converter units in parallel or in series. Connections of each converter unit are either to separate windings of a common transformer or to separate transformers.

In general, the increased complexity of multi converter units needs to be evaluated with regard to project specific requirements.

4.4 Semiconductors for VSC transmission

In normal operation of voltage sourced converters, the power semiconductors are exposed to a unipolar voltage and need to be able to conduct the current in both directions. Therefore, power semiconductor switches with turn-on and turn-off capability and with a high voltage blocking capability (typically several kV) in the forward direction are needed.

Today, these requirements are usually achieved by a parallel connection of a turn-off semiconductor device and a so-called free-wheeling diode as shown in Figure 13. However, one variant of the IGBT, the bi-mode insulated gate transistor (BiGT), allows bidirectional conduction of current in the same silicon wafer and therefore does not need a separate free-wheeling diode.

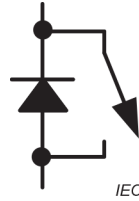

Figure 13 – Symbol of a turn-off semiconductor device and associated free-wheeling diode

Various different turn-off semiconductor devices are suitable for VSC technology, but only IGBTs (insulated gate bipolar transistor, as shown in Figure 14) and variants of the IGBT such as the BiGT and the injection enhanced gate transistor (IEGT) are used in commercial VSC-HVDC projects that have been built to date. Therefore the description of turn-off semiconductor devices in this document is concentrated on IGBTs, although other semiconductors such as GTOs and IGCTs are also usable.

NOTE Semiconductor devices suitable for VSC transmission type are divided into two categories: the "transistor" type, which includes IGBTs, and the "thyristor" type, which includes GTOs and IGCTs. Devices of the "thyristor" type can handle larger powers than devices of the "transistor" type, but lack certain control features such as the ability to control the device smoothly between the off and on states using active gate control. Devices of the "thyristor" type also have higher gate power consumption than devices of the "transistor" type, which makes their use in high voltage applications such as VSC transmission more difficult for the time being. Study of the application of devices of the "thyristor" type, such as IGCTs, is still going on.

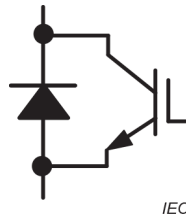

Figure 14 – Symbol of an IGBT and associated free-wheeling diode

Like all diodes, the free-wheeling diodes, which are connected in parallel to the controllable switch, have a significant reverse recovery current when they turn off. Both the IGBTs as well as the free-wheeling diodes need to cope with these switching transients, particularly current gradients and voltage gradients.

An IGBT is a voltage controlled device; only capacitive currents can flow in the gate terminal. The device can be controlled at any instant, even during the switching transients, i.e. the load current can be influenced by the gate voltage.

IGBTs are short-circuit proof within defined operating conditions. This means that in case of a short circuit, the IGBT limits the load current to several kiloamperes (a process usually known as de-saturation). Within some microseconds, an appropriate gate turn-off signal needs to be applied to turn off the fault current and not to thermally overstress the device.

Switching times of IGBTs are in the range of microseconds or less. Furthermore, the switching slopes can be adjusted by the gate drive circuit, achieving the optimal waveforms concerning over-voltage peaks and switching losses. Snubbers to keep the rates of rise of current and voltages to acceptable limits are not necessary in many cases. The gate drivers for IGBTs can be simple, since they need to deliver only a few watts of control power to the gate.

High power IGBTs are made up by a parallel connection of chips to achieve the required current capability. The chips are mounted in press packs or module housings. In most cases, the FWD chips are included in the same housing.

Press pack housings are intended to be clamped between heat sinks; the paths for current and heat are the copper poles of collector and emitter of the devices that are separated by a ring of insulating material. For high voltage devices, this material is high strength porcelain in most cases, though glass fibre reinforced resin is also used.

Module IGBTs are designed for single sided cooling and are mounted on heat sinks by screws; spring loaded clamping is not necessary. The electrical terminals are on the top side of the module; the heat flows through the base plate of the module to the heat sink. Since the electrical part of the module is insulated to the base plate, it is possible to mount modules with different voltage potentials on a shared heat sink.

5 VSC transmission converter topologies

5.1 General

For a high power VSC transmission system, the key issue that determines the cost and operating losses of the overall system is the power circuit structure to construct the AC output voltage waveform. The output voltage waveform needs to approximate a sine-wave in order to eliminate or minimize the need for harmonic filtering. The switching converter considered for practical implementation is a voltage sourced converter operated with a fixed DC voltage. The converter is a combination of turn-off semiconductor devices that connect the DC input voltage periodically to the output for some intervals to produce the AC output voltage. The converters at each end of a VSC transmission system can be arranged in a number of different ways, with the configuration of the converter normally being referred to as its topology. At the time of writing, two different converter types have been used for commercial projects: those in which the converter valves act as controllable switches and those in which the converter valves act as controllable voltage sources. These two types are described in 5.2 and 5.3 respectively.

Some other converter topologies which share the characteristics of both the controllable switch and controllable voltage source types have been described in the literature [1]¹.

It is a fundamental criterion for any viable topology that it enables the functional requirements to be met. Different topologies have different technical characteristics, and therefore allow the overall scheme to be optimized in different ways. Manufacturers can have different preferred topologies and be able to best optimize their proposals around this preferred topology. It is recommended that customers do not stipulate the topology to be used for a VSC transmission system, unless there are compelling reasons for doing so.

It is possible to arrange the converters to have a single-, three- or multi-phase AC output/input. For the purpose of this document, only the three-phase arrangement will be discussed.

5.2 Converter topologies with VSC valves of switch type

5.2.1 General

The converter switches (normally called VSC valves) perform the function of connecting the AC bus to the DC terminals. If the connection is direct through two alternately operating switches, the AC bus voltage will change between the voltage levels at the two DC terminals. Such a converter is known as a 2-level converter. In the 2-level converter, each of the VSC valves needs to withstand the voltage between the two DC terminals.

¹ Numbers in square brackets refer to the Bibliography.

If the DC capacitor is subdivided, or additional DC capacitors are added, it is possible to arrange for the AC voltage to move not only to the voltage at one of the two DC terminals but also to intermediate levels. The number of voltage levels to which the AC bus voltage can be switched will depend on the number of valves and the number of DC capacitor subdivisions or additional DC capacitors. These arrangements are known as 3-level or multi-level converters, depending on the number of voltage levels that can be achieved. The term multilevel refers to a converter phase unit topology where the AC bus can be switched to attain more than three different voltage levels.

In 3-level or multi-level topologies, the VSC valves do not normally need to be designed for the full DC terminal-to-terminal voltage. For example, in normal operation, each valve in a 3-level converter topology experiences only 50 % of the terminal-to-terminal DC voltage. Similarly, in normal operation, each VSC valve in an n -level topology experiences only the terminal-to-terminal DC voltage of the phase unit divided by $(n - 1)$.

In 5.2.3 and 5.3, converter topologies suitable for VSC transmission systems will be described in more detail. It is noted that a considerable research and development effort is being invested in voltage sourced converter technology, so additional suitable topologies will likely become available subsequent to the issue of this document.

5.2.2 Operating principle

The basic operating mechanism of an ideal VSC is covered in 5.2.2. The description is initially limited to a 2-level VSC. The 2-level VSC is the simplest structure needed to convert a DC voltage into AC voltages. Although other types of multi-level VSCs are more complex, their basic operating principle does not differ from that of the 2-level VSC.

For the purpose of illustration, the VSC valves are described as ideal switches without any switching losses. A VSC valve in a real application consists of a large number of series-connected semiconductor devices, and is described in greater detail in 5.4. The stray inductances are neglected here, and the DC capacitors have been assumed to have infinite capacitance – i.e., no DC voltage ripple is shown.

As explained in 4.1, the output of the VSC needs to be connected in series with a phase reactor. The phase reactor enables the VSC to control power flow in addition to smoothing the output current.

5.2.3 Topologies

5.2.3.1 Two-level converters

A 2-level converter is the simplest switching arrangement capable of producing AC output from a DC source in the form of a simple square-wave. A three-phase converter using three 2-level phase units is illustrated in Figure 15.

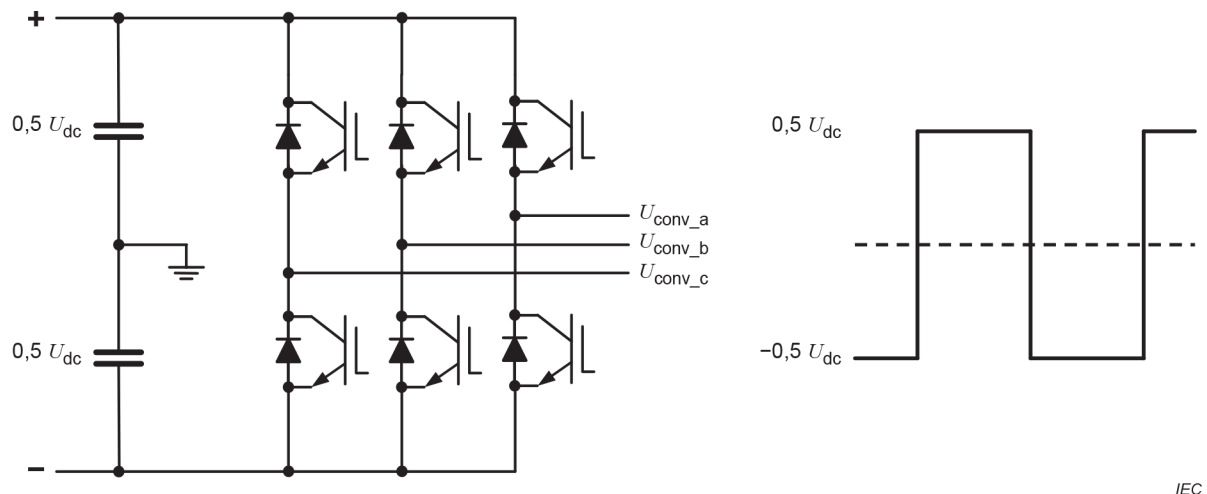

Figure 15 – Diagram of a three-phase 2-level converter and associated AC waveform for one phase

The AC waveform shown in Figure 15 is the phase-to-neutral voltage. The neutral voltage is the average voltage of the converter's two DC terminals.

Since the square-wave output voltage shown in Figure 15 is not acceptable in a practical HVDC scheme, this converter type is normally operated with pulse width modulation (PWM) as described in 9.3.

A typical PWM-switched waveform, using a carrier-based control method with a switching frequency of 21 times the fundamental frequency, is given in Figure 16. For the purpose of this illustration, the DC capacitor has been assumed to have an infinite capacitance (i.e., no DC voltage ripple).

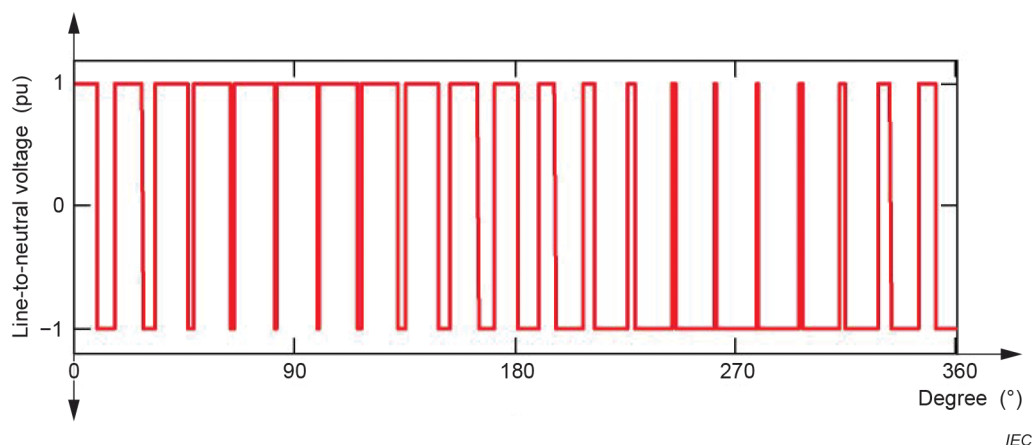

Figure 16 – Single-phase AC output for 2-level converter with PWM switching at 21 times fundamental frequency

Other PWM techniques are also available, such as optimized PWM (OPWM) or selective harmonic elimination method (SHEM). These aim to improve the compromise between power transfer capability, switching frequency and harmonic performance.

5.2.3.2 Three-level neutral-point clamped (NPC) converters

A three-phase converter consisting of three 3-level phase units is illustrated in Figure 17. The converter has three DC terminals to connect to a split or centre-tapped DC source. As seen, there are more valves used than in the 2-level phase unit, and additional diodes or valves are

required to connect to the DC supply centre-tap, which is the reference zero potential. However, with identical valve terminal-to-terminal voltage rating, the total DC supply voltage can be doubled so that the output voltage per valve remains the same.

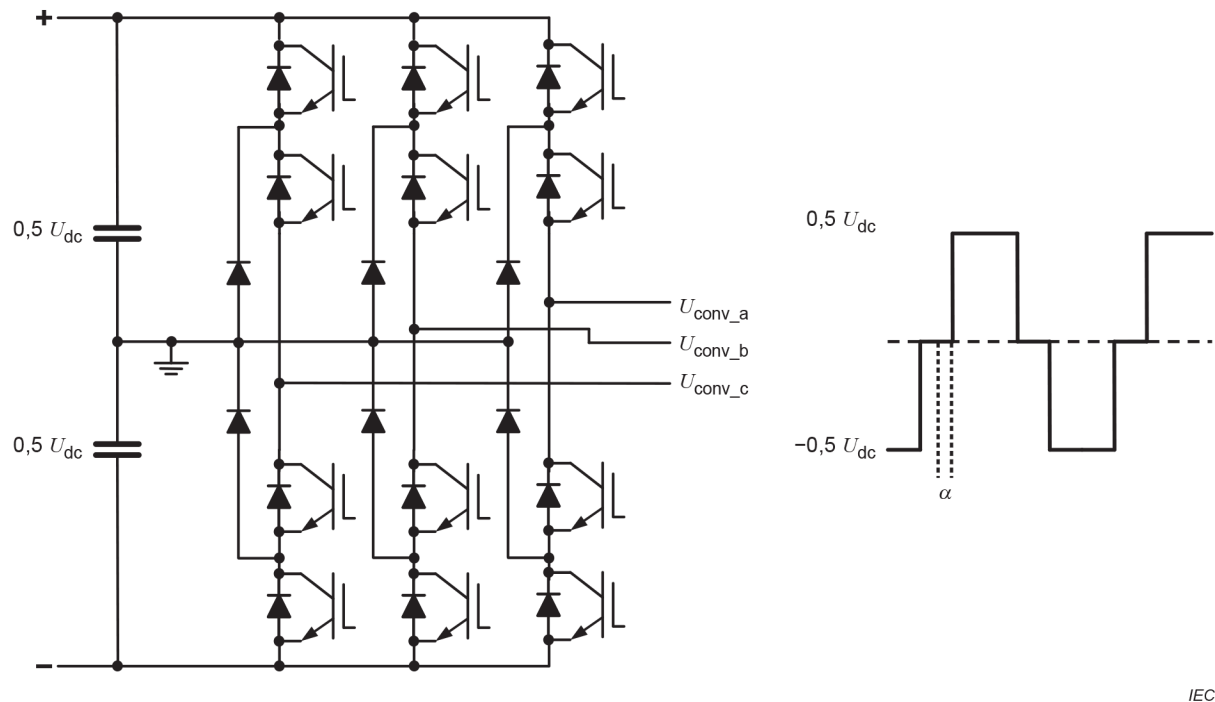

Figure 17 – Diagram of a three-phase 3-level NPC converter and associated AC waveform for one phase

NOTE The neutral-point clamping diodes shown in Figure 17 can be replaced by IGBTs in some applications.

The AC waveform shown in Figure 17 is the phase-to-neutral voltage. The neutral voltage is the voltage at the midpoint of the DC capacitor. As illustrated in Figure 17, the output voltage of the 3-level phase unit can be positive, negative, or zero. Positive output is produced by gating on both upper valves in the phase unit, while negative output is produced by gating on both lower valves. Zero output is produced when the two middle valves, connecting the centre tap of the DC supply via the two diodes to the output, are gated on. At zero output, positive current is conducted by the upper-middle controllable device and the upper centre-tap diode, and negative current by the lower-middle controllable device and the lower centre-tap diode.

As indicated in Figure 17, the relative duration of the positive (and negative) output voltage with respect to the duration of the zero output is a function of control parameter α , which defines the conduction interval of the top upper and the bottom lower valves. The magnitude of the fundamental frequency component of the output voltage produced by the phase unit is a function of parameter α . When α equals zero degrees, it is maximum, while at α equals 90° , it is zero. Thus, one advantage of the 3-level phase unit is that it has an internal capability to control the magnitude of the output voltage without changing the number of valve switching events per cycle.

The operating advantages of the 3-level phase unit can only be fully realized with some increase in circuit complexity, as well as more rigorous requirements for managing the proper operation of the converter circuit.

An additional requirement is to accommodate the increased AC ripple current with a generally high triplen harmonic content flowing through the mid-point of the DC supply. This can necessitate the use of a larger DC storage capacitor or the employment of other means to minimize the fluctuation of the mid-point voltage. However, once these problems are solved,

the 3-level phase unit provides a useful building block to structure high power converters, particularly when rapid AC voltage control is needed.

In common with the two-level converter, this converter is normally operated with PWM. A typical PWM switched waveform, using a carrier-based control method with a frequency of 21 times fundamental frequency, is given in Figure 18. For the purpose of this illustration, the DC capacitor has been assumed to have an infinite capacitance (i.e., no DC voltage ripple).

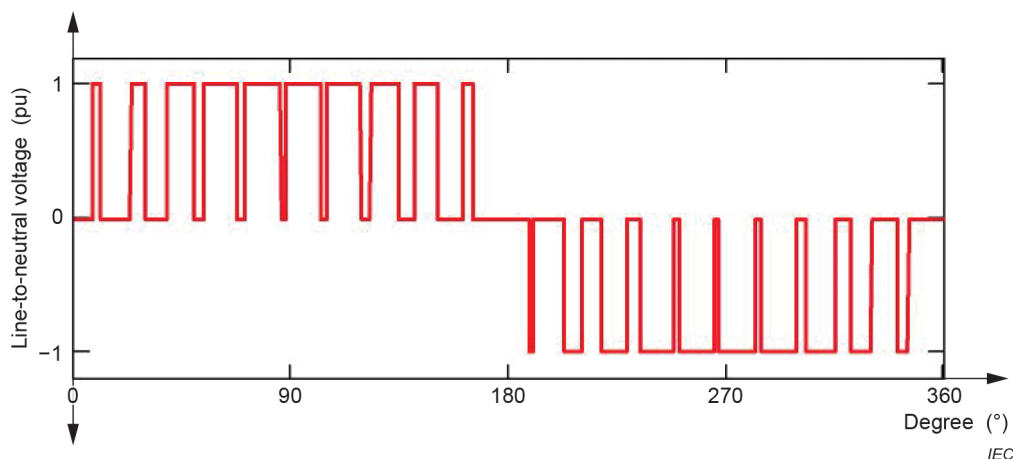

Figure 18 – Single-phase AC output for 3-level NPC converter with PWM switching at 21 times fundamental frequency

5.2.3.3 Other multi-level converter topologies

The neutral-point clamped circuit can be extended to higher numbers of output levels, for example 5 levels, but at the expense of disproportionately greater complexity. Another converter type which has been used in some power electronic applications is the "flying capacitor" or "floating capacitor" circuit, which can also exist in 3-level and 5-level forms but suffers the same disproportionately greater complexity as the number of output levels is increased. These and other possible multi-level converter topologies are described in [2], [3].

5.3 Converter topologies with VSC valves of the controllable voltage source type

5.3.1 General

With valves of the controllable voltage source type, each VSC level is effectively a single-phase VSC in its own right, and contains power semiconductors and a capacitor for energy storage. Each level has two main terminals used for the series connection of the VSC levels within the valve. By appropriate control of the IGBTs within the valve level, either the voltage of the capacitor or zero volts can be applied to the main terminals of the VSC level.

By individual and appropriate control of the VSC valve levels, a desired voltage can be generated at the valve terminals. The valve voltage is the sum of the capacitor voltages of the submodules that are in the active state (i.e. in which the capacitor voltage is applied to the main terminals of the VSC level). The VSC valve submodules or cells are controlled such that the sum of the voltages of the upper arm and lower arm of one phase unit equals to the DC voltage whereas the instantaneous voltage on the AC terminals is determined by the difference between the voltages of the two converter phase arms of one phase unit.

Assuming infinite storage capacitances with equal voltages in the individual MMC building blocks, $n + 1$ different voltage steps can be applied to the terminals of a valve consisting of n valve levels. Assuming a high number of VSC levels per valve, the topology can be approximated by electrical equivalent as shown in Figure 19. Each valve can be considered as a controllable voltage source.

The valve reactors contribute to both the phase reactance and the DC reactance, and are essential for the current control within the phase units. Furthermore, they also limit the peak current and current gradients in case of severe faults, such as short circuit between the DC terminals.

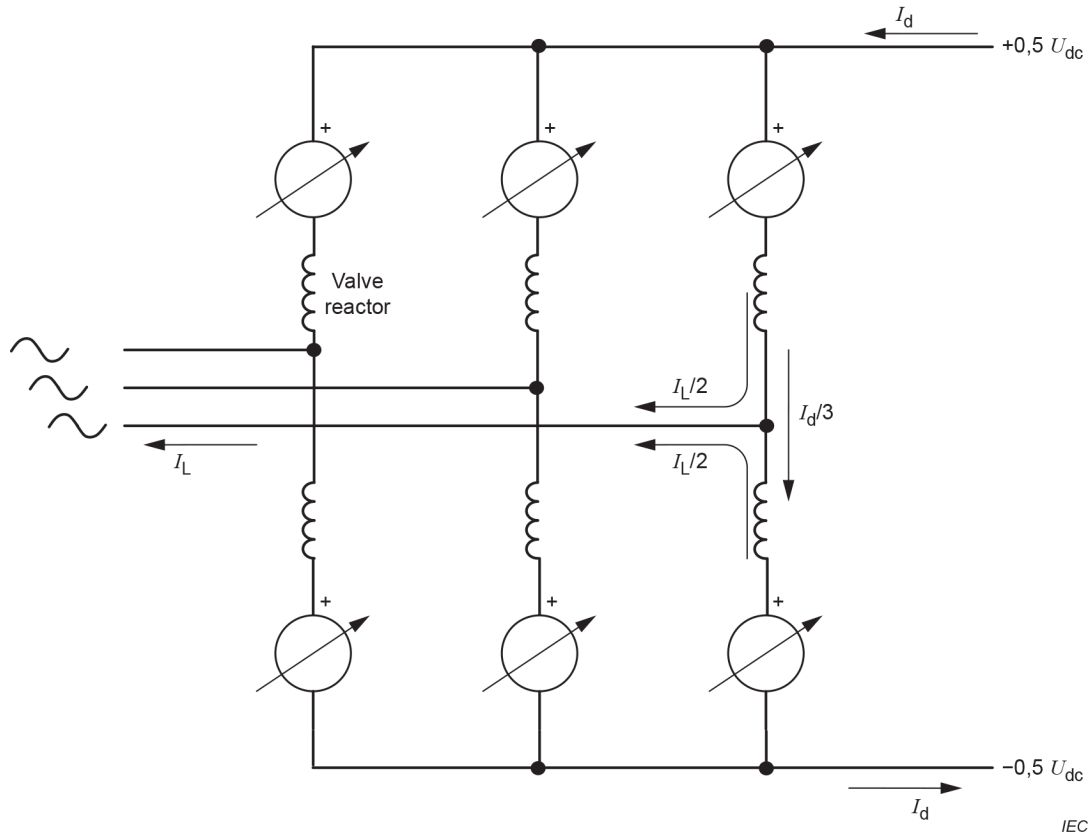

Figure 19 – Electrical equivalent for a converter with VSC valves acting like a controllable voltage source

Because of its modular design and the multi-level technology, it is referred to as modular multi-level converter (MMC) topology. For the design of the individual VSC levels, different power building blocks can be used. At the time of writing, three different topologies are used:

- MMC with VSC levels in half-bridge topology;
- MMC with VSC levels in full-bridge topology;
- MMC with VSC levels in a mixture of half-bridge and full-bridge topologies.

Since the circuit is inherently modular, it is relatively straightforward to obtain high numbers of output levels, without requiring either PWM or series-connected IGBTs. Thus, AC filters can be omitted in many cases and considerations of voltage distribution amongst series-connected IGBTs do not arise.

This type of converter can also be realized with multiple IGBTs connected in series in each controllable switch, giving an output voltage waveform with fewer, larger, steps than the MMC. This configuration is referred to as the cascaded two-level (CTL) converter but is functionally identical to the MMC in every aspect apart from the harmonic performance which can be slightly poorer.

5.3.2 MMC topology with VSC levels in half-bridge topology

Each of the 6 variable voltage sources shown in Figure 19 is realized with a series connection of identical VSC valve levels with an electrical equivalent as shown in Figure 20. The VSC

valve level is a two-terminal component with its own DC storage capacitor unit as shown in Figure 20. These VSC valve levels are individually controlled and can be switched between a state with full submodule voltage (voltage of the associated storage capacitor) and a state with zero submodule voltage for both current directions. If the submodule voltage is applied to the VSC valve level terminals, the capacitor can be charged and discharged dependent on the current direction of the converter arm.

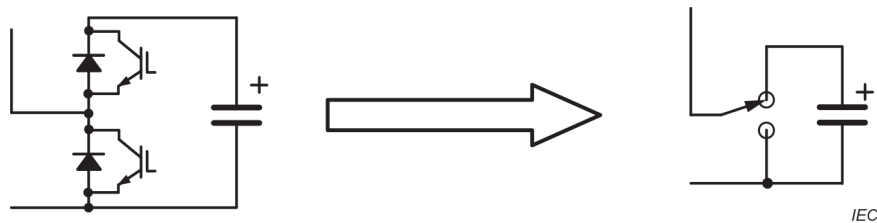

Figure 20 – VSC valve level arrangement and equivalent circuit in MMC topology in half-bridge topology

The typical electrical arrangement of VSC valve levels and valve reactors in a converter block is shown in Figure 21.

NOTE The valve reactors can be located on either the AC or DC side of the valves.

The VSC valve levels are controlled in that way that the sum of the upper arm and lower arm of one phase unit equals to the DC voltage whereas the instantaneous voltage on the AC terminals is determined by the difference of the voltages of the two converter arms of one phase unit.

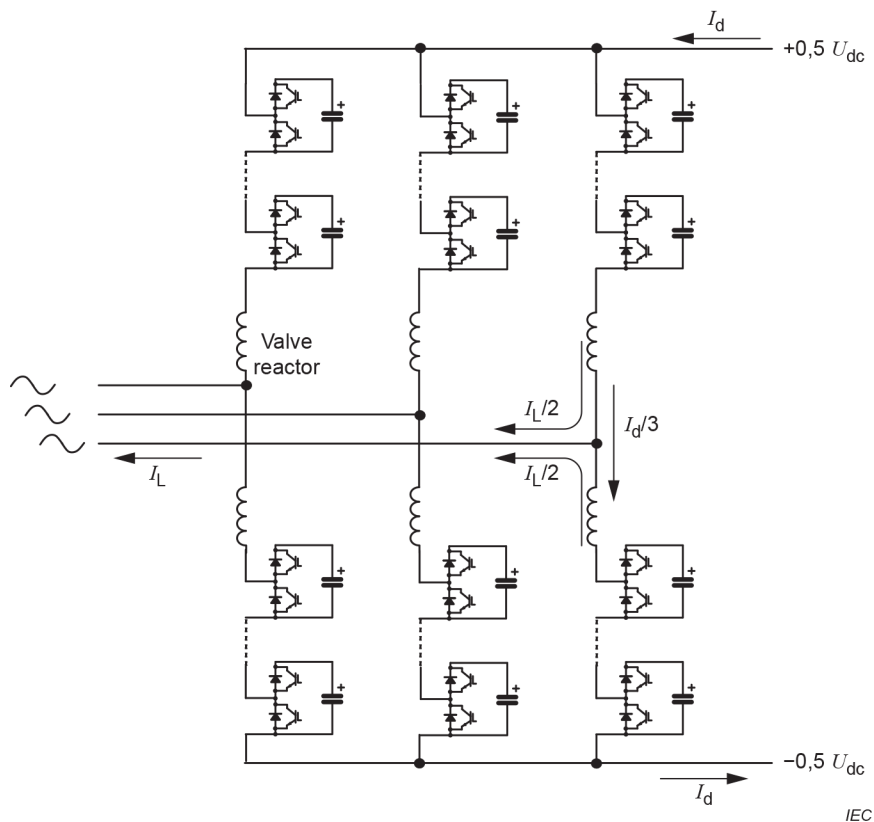

Figure 21 – Converter block arrangement with MMC topology in half-bridge topology

5.3.3 MMC topology with VSC levels in full-bridge topology

The MMC topology with "full-bridge" VSC levels operates on very similar principles to that based on half-bridge VSC levels. The principal difference is that each VSC level consists of one storage capacitor and four IGBTs in a bridge configuration as shown in Figure 22.

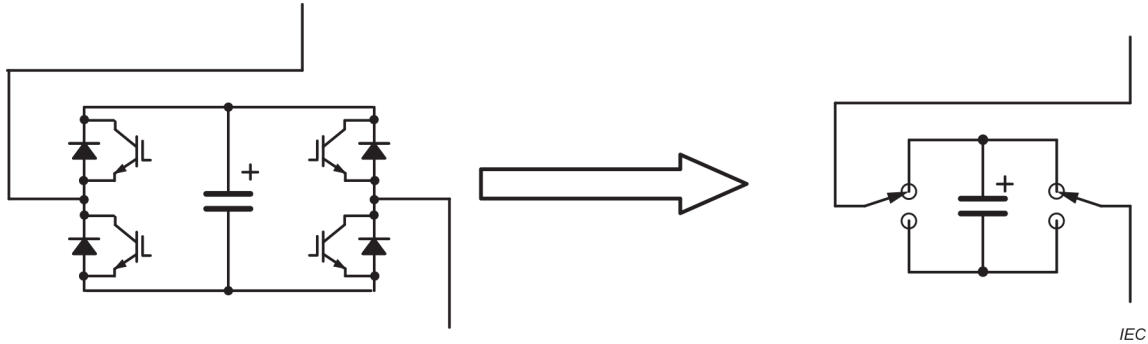

Figure 22 – VSC valve level arrangement and equivalent circuit in MMC topology with full-bridge topology

In common with the half-bridge submodule configuration, each VSC level in the full-bridge configuration is capable of producing an output voltage of zero or a positive output voltage equal to the capacitor voltage. However, it can alternatively produce a negative output voltage equal to the capacitor voltage.

In contrast to the converter arrangements outlined in 5.2 and 5.3.2, this converter arrangement is capable of producing a DC output voltage of either polarity, a feature which can be beneficial in applications where a VSC transmission station is connected as a tap onto an existing line commutated HVDC link or when the HVDC scheme uses a line commutated rectifier and a voltage sourced inverter.

A second advantage of the full-bridge circuit is that it permits faults on the DC side of the converter to be cleared by using only the power semiconductors in the valve, without requiring any additional switchgear.

On the other hand, the full-bridge circuit requires, in principle, twice the number of IGBTs compared with the half-bridge circuit.

5.3.4 CTL topology with VSC cells in half-bridge topology

Each of the 6 variable voltage sources shown in Figure 19 is realized with a series connection of identical VSC valve cells. One VSC valve cell acts as a single-phase two-level converter and functions electrically equivalent to one level of the MMC described in 5.3.2, except that the voltage rating is higher. Instead of a single IGBT-diode pair in each switch position, multiple IGBT-diode pairs are connected in series and synchronously controlled as one switch in one CTL cell.

The typical electrical arrangement of VSC valve cells and valve reactors in a converter block is similar to Figure 21. The MMC building blocks depicted in Figure 21 are substituted by valve cells in CTL topology.

The cell DC capacitor voltage in the CTL topology corresponds to one valve voltage step.

5.3.5 CTL topology with VSC cells in full-bridge topology

The CTL topology with "full-bridge" VSC cells functions similarly, in principle, to the MMC topology with VSC levels in full-bridge topology, in 5.3.3. The main difference between CTL topology with VSC cells in full-bridge topology and MMC topology with VSC levels in

full-bridge topology is the number of IGBT-diode levels per CTL cell or MMC level. Each CTL cell consists of one IGBT-diode pair in each switch position.

5.4 VSC valve design considerations

5.4.1 Reliability and failure mode

In addition to the number of series-connected valve levels that are needed to sustain the converter voltage rating, each single valve in a VSC transmission scheme needs to include a few redundant valve levels. In case of failure of an individual valve level component, uninterrupted operation of the remaining healthy valve levels is mandatory. Therefore, a faulty valve level needs to safely and controllably enter into a short-circuit mode and be capable of conducting current until it can be changed out, for example during a scheduled maintenance period.

This capability of short-circuit failure mode (SCFM) operation is very critical for series-connected valve levels, and needs to be verified by appropriate tests under conditions that are relevant for a particular application. Some special designs of presspack IGBT allow SCFM to be assured. Module IGBTs, however, do not exhibit this behaviour and a faulty module IGBT can result in an open circuit. Thus, additional components in parallel to the valve level terminals are required to ensure SCFM.

The operating voltage of the IGBT needs to be selected to be low enough to achieve an adequately low failure-in-time (FIT) rate.

In selecting the operating voltage and current of the IGBT, due consideration needs to be given to the load cycling requirements for the VSC system.

5.4.2 Current rating

One of the important design bases of the semiconductor in the VSC valve is rated current. In addition, the valve needs also to be able to handle peak current, including ripple and transients, as well as margins for control and protection actions including converter valve blocking delays and circuit breaker operating time. The rated arm current gives the nominal stress on the component and needs to be considered regarding power losses and junction temperature on the IGBT.

5.4.3 Transient current and voltage requirements

An important aspect of IGBTs is their capability to turn on and turn off current and voltage. This capability is defined in the switching safe operating area (SSOA) shown in Figure 23. There are several types of SSOA, including the Reverse Bias Safe Operating Area (RBSOA) which defines the turn-off capability of the IGBT and the Reverse Recovery Safe Operating Area (RRSOA) which defines the turn-off capability of the free-wheeling diode.

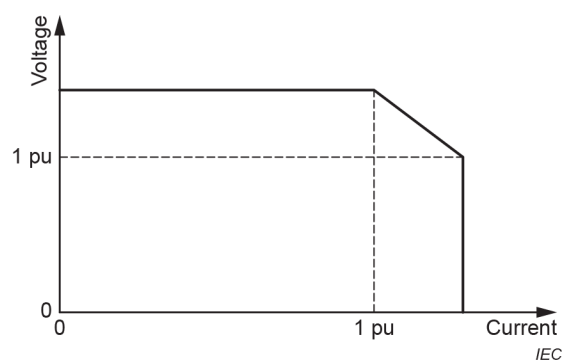
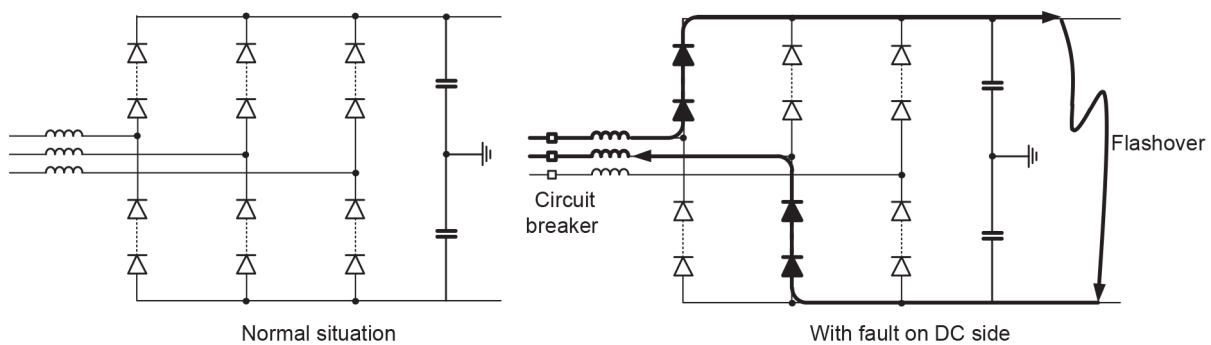

Figure 23 – Typical SSOA for the IGBT

During switching, the IGBT is able to turn off the peak current, including ripple. Additionally, a margin is added to handle current control regulation and protection actions during transient conditions. The valve is also able to turn off the current which results from a short circuit occurring close to the valve. The IGBT short-circuit operation capability is defined by the SCSOA (short-circuit safe operating area), which is slightly different from the SSOA under normal operation.

5.4.4 Diode requirements

In many converter topologies (including the 2-level and 3-level converters and the MMC with half-bridge topology), the free-wheeling diodes (FWD) in a VSC bridge act as an uncontrolled rectifier bridge. Thus they can be exposed to severe transient overcurrents, for example during DC-side short circuits or at energization.



IEC

Figure 24 – A 2-level VSC bridge with the IGBTs turned off

In case of a DC side fault, as shown in Figure 24, a short circuit between the two DC terminals creates a fault current path through the diodes. The current in the AC phases in the VSC bridge is limited only by the short-circuit impedance of the AC network and the reactance in the converter, for example the phase or valve reactors and/or transformers. The fault current is detected by the protection system, which will open the breaker on the AC side and thereby eliminate the fault current. A normal protection and breaker scheme takes a time equivalent of three 50/60 Hz fundamental frequency cycles before the fault current is extinguished. If the DC system only consists of cables, a fault will be very unlikely. However, the consequences might not be acceptable if the system is not designed to handle the fault. The valve is designed to handle the fault current with an asymmetrical offset as a worst case. Here, no reapplied voltage occurs since the breaker has disconnected the AC system.

Another transient that the diode can experience occurs if the VSC is energized through the AC breaker when there is either no voltage, or a low voltage, on the DC side. In this case, the converter experiences a surge inrush current and an overvoltage will occur on the DC bus. The valve is designed to handle the inrush current, or the current will need to be limited. The normal method for doing this is to include pre-insertion resistors.

5.4.5 Additional design details

Besides controlling the turn-off semiconductor device in regular operation, the gate unit needs to keep the switching device within the safe operating area in all other operational and short-circuit conditions. IGBTs have proven comparatively easy to handle in this respect, thereby facilitating precise control of switching waveforms. This, in turn, is necessary for achieving proper control and protection strategies for the converter.

The switching transients which appear when the IGBT turns on or off give stress to the IGBT and other components in the valve levels. The energy stored in stray inductances and capacitances will generate transient voltages and currents respectively.

Gate voltage control makes it possible to control the voltage between the main two terminals of the IGBT during the turn-on and turn off processes. Suppressing the speed of turn off makes the energy stored in the loop stray inductance dissipate in the IGBT itself. Applying the gate voltage control technology, the snubber circuit can be omitted from the circuit, although switching losses in the IGBT become larger.

For converter topologies with VSC valves of switch type, it is possible to design the VSC valve such that it does not use traditional snubber circuits for protecting the individual IGBTs. In this case, the IGBTs themselves maintain sufficient voltage sharing, both during switching and blocked conditions, by means of gate control and DC grading resistors. This, in turn, requires a small spread in device data concerning characteristic switching times, switching transient properties, and leakage currents in the blocked state.

Converter topologies with VSC valves of the controllable voltage source type only require synchronized switching of individual valve levels when multiple IGBTs are connected in series in each switch position (as in the cascaded two-level converter). Where no direct series connection of IGBTs is used, a coordination of IGBTs switching properties of individual valve levels is not required.

5.5 Other converter topologies

The technical field of VSC transmission is developing rapidly. Accordingly, it is to be expected that other converter topologies in addition to those described above will emerge. Some existing known topologies are already described in [3].

Purchasers of VSC transmission schemes need to consider such alternative converter topologies on their merits and not limit the permitted circuit topologies to those that have been described in 5.2 and 5.3.

5.6 Other equipment for VSC transmission schemes

5.6.1 General

According to its principle of operation, only a few components are essential in a voltage sourced converter (VSC). These are

- a means to convert DC into AC voltages provided by a converter comprising VSC valves and controls;
- an AC side reactance provided by phase reactors/valve reactors, transformers, or a combination thereof;
- a DC voltage source provided by at least one VSC DC capacitor, submodule DC capacitor or cell DC capacitor.

In addition to these key components, a complete VSC substation can also need

- AC and DC filters,
- surge arresters,
- circuit breakers and switches, and
- measuring equipment.

The above equipment items are not always necessary in all converter topologies, but differ due to the real requirements because different components are stressed differently in the different topologies.

5.6.2 Power components of a VSC transmission scheme

Figure 1 shows the basic structure of a VSC substation and the location of the major power components. Depending on the design concept and the VSC substation topology, several

components might occur more than once in a real structure, while others might not be needed. The functions and important design aspects of each component are briefly explained in 5.6.3 to 5.6.11.

5.6.3 VSC substation circuit breaker

The VSC substation circuit breaker is located at the feeder from the AC transmission system to the VSC transmission scheme. Its main function is to connect and disconnect the VSC substation to and from the AC system. There are no special requirements compared to what is common practice for circuit breakers used for AC substation applications.

Depending on the start-up concept of the VSC transmission scheme, a circuit breaker can be equipped with a closing resistor, or a separate resistor, with either a circuit breaker or disconnecter in parallel with it, can be provided in series with the main circuit breaker. The resistor reduces the charging currents of the DC circuit, resulting in smaller temporary AC system disturbances and lower stresses on the free-wheeling diodes during energization.

5.6.4 AC system side harmonic filters

Depending on the converter design and AC system conditions, filtering can be required to prevent VSC-generated harmonics from penetrating into the AC system or to prevent amplification of background harmonics on the AC system.

As a side effect, harmonic filters generate fundamental frequency reactive power which needs to be considered in the overall P-Q operating range of the VSC system. The design principles of system side harmonic filters and any associated circuit breakers do not differ from the design practice for HVDC systems with line-commutated converters (LCC) or flexible alternating current transmission systems (FACTS). High pass, single, double or triple tuned filters can be used as described in IEC TR 62001-1 [4].

5.6.5 Radio frequency interference filters

Radio frequency interference (RFI) filters reduce to acceptable limits the penetration of high frequency (HF) harmonics into the AC system.

HF harmonics generated require special attention during the design of a VSC substation. To calculate line-carried HF harmonics, a detailed representation of the VSC substation layout is necessary, including the structure and geometry of power components, busbars and grounding system. Additionally, the current and voltage waveforms experienced during the conversion process need to be known.

The design principles for the RFI filter do not differ from the design practice for LCC HVDC or FACTS.

5.6.6 Interface transformers and phase reactors

In many cases, the VSC substation design will include interface transformers. In general, they can fulfil the following tasks:

- 1) provide a reactance between the AC system and VSC unit;
- 2) adapt a standard AC system voltage to a value matching the VSC AC output voltage and allow optimal utilization of VSC valve ratings;
- 3) connect several VSC units together on the AC side that have different DC voltage potentials;
- 4) prevent zero sequence currents from flowing between the AC system and VSC unit.

Depending on the design concept applied to the VSC substation, the reactance mentioned under point 1) can be provided by a phase reactor, a transformer, or a combination thereof.

The reactance is necessary to allow control of the AC output current of the VSC. Design criteria to determine the size of the reactance are

- the required dynamic behaviour of the system,
- the tolerable harmonic content of the converter AC current, and
- constraints revealed from analysis of transient conditions and fault scenarios.

If points 2) to 4) do not apply under specific circumstances, the required reactance could be provided by phase reactors, which would eliminate the need for a transformer.

For the design of reactors or transformers, the following points need to be taken into account:

- DC voltage stress on converter winding insulation to ground, for the cases of asymmetrical monopole or bipole;
- stresses due to fundamental current;
- saturation characteristics with respect to possible AC harmonic and DC flux components;
- stresses due to harmonics in the lower and middle frequency range;
- dielectric stresses due to harmonics in the middle and upper frequency range, particularly for VSC valves of the switch type;
- dielectric stresses due to normal operating voltage and transient voltages occurring during fault scenarios.

Particularly in the case of high-voltage VSC valves of the switch type, the magnitudes of the harmonic voltages generated require detailed design studies to provide reliable information about the voltage and current profiles along windings. The interface transformer does not require a tap changer. However, if a tap changer is used, it is possible to optimize the VSC operation, for example to achieve reduced power losses or to increase power capability under low-voltage conditions.

5.6.7 Valve reactor

For valves of the controllable voltage source type, valve reactors are connected in series to the VSC valve levels as shown in Figure 19. These reactors have several different functions:

- the three-phase units represent three DC voltage sources, connected in parallel. During operation, these voltages cannot be exactly equal, resulting in circulating currents between the three-phase units. The valve reactors limit these circulating currents and enable to control them;
- the valve reactors limit the valve short-circuit current;
- the valve reactors are a contribution to the interface impedance between the converter and the AC network;
- in some designs, the valve reactors can be combined with tuning capacitors and play a role in limiting circulating harmonic currents between phases.

NOTE The valve reactors can be placed in several locations, for example at the DC terminals, at the AC terminals, distributed amongst the valve submodules or integrated into the same tank as the interface transformer.

5.6.8 DC capacitors

5.6.8.1 VSC DC capacitor

5.6.8.1.1 General

The VSC DC capacitor, in conjunction with the DC cable (where used), provides the DC voltage necessary to operate the VSC. It is connected directly in parallel to the DC terminals of the VSC phase units. For the design of the VSC DC capacitor, the following aspects need to be considered.

5.6.8.1.2 Commutation circuit inductance

Switching the semiconductor devices of the VSC causes HF commutation current to flow through the commutation circuit formed by the switching valves, the VSC DC capacitor, and the connecting bus bars. Due to the stray inductance within the commutation circuit, these HF currents result in transient voltage stresses on the switching valves. To minimize these stresses, the inductance of the connection of the VSC DC capacitor to the valves usually is as low as possible.

5.6.8.1.3 DC voltage ripple

VSC operation results in harmonic currents flowing in the DC circuit. These harmonic currents cause harmonic voltages (also known as DC voltage ripple). The following factors will influence the size of the DC voltage ripple:

- imbalances in the AC system and/or converter operation;
- pre-existing harmonics in the AC network;
- VSC valve switching strategy.

5.6.8.1.4 Capacitance of the VSC DC capacitor

The VSC DC capacitance needs to be large enough to keep the DC voltage ripple within tolerable limits.

5.6.8.1.5 Control aspects

The DC voltage influences active and reactive power exchange with the AC system. To achieve stable operation of the transmission system, it is important to keep the DC voltage within tight limits. Changing power orders, AC system unbalances, or system transients change the operating conditions of the VSC and can cause DC voltage fluctuations or oscillations. Due to its energy storage capability, the VSC DC capacitor stabilizes the operation of the VSC.

Important design parameters of the VSC DC capacitor are as follows:

- maximum DC voltage for continuous operation;
- maximum acceptable DC voltage variations under transient conditions, such as faults on the AC system.

5.6.8.1.6 Harmonic coupling of different VSC substations connected to one DC circuit

Harmonic currents generated by a VSC cause harmonic voltages not only on their own VSC DC capacitor, but also on the VSC DC capacitors in other VSC substations connected to the same DC circuit. As a result, the different VSC substations in a transmission scheme become mutually coupled via the DC circuit. To avoid unwanted interactions between the VSC substations, this coupling is reduced to the largest extent possible. The capacitance of the VSC DC capacitor is an important factor influencing the coupling between the VSC substations.

5.6.8.2 Submodule/cell DC capacitor

5.6.8.2.1 General

In principle, the design and function of the submodule/cell capacitors for the MMC and CTL technologies are similar to that of the VSC DC capacitors.

However, due to their operation principle, the current stresses are different for DC submodule or cell capacitors. The individual submodules or cells can be individually switched off or on depending on output voltage generation. When the submodule is switched off the valve

current does not pass through the DC submodule/cell capacitor and the capacitor current is zero. Conversely, when the submodule or cell is switched on, the full valve current flows through the capacitor. In the "on" state, components of DC current and fundamental and low order harmonic currents need to be considered. The current flow in the "on" state results in a significant ripple voltage of the submodule/cell capacitors per power cycle. The average and RMS capacitor current stresses are calculated based on current contribution in the "on" state.

5.6.8.2.2 Commutation circuit inductance

Similar to the VSC DC capacitor, switching the semiconductor devices of the submodule causes HF commutation current to flow through the commutation circuit of the submodule. Due to the stray inductance within the commutation circuit, these HF currents result in transient voltage stresses on the submodule. To minimize these stresses, the inductance of the submodule is as low as possible.

5.6.8.2.3 DC voltage ripple

a) Submodule capacitor voltage ripple

As mentioned before, the ratio of the voltage ripple to DC voltage of the submodule capacitor is larger than that of VSC DC capacitors.

b) DC link voltage ripple

The DC link voltage ripple of the MMC is much lower than that of the VSC DC capacitors of 2-level or NPC converters, because the MMC DC link voltage is almost the same as the sum of the output voltage of submodules in a phase leg. By shifting the output voltage pulse of each submodule, the DC link voltage ripple of the MMC is small.

5.6.8.2.4 Capacitance of the MMC submodule capacitor

The MMC submodule capacitance needs to be large enough to keep the voltage ripple of submodule capacitor within tolerable limits.

5.6.8.2.5 Control aspects

In addition to the control aspects of the VSC DC capacitors, the submodule capacitors have some control aspects described below.

- MMCs have many submodule capacitors, whose voltages can tend to become unbalanced. Therefore, a balancing control is required in order to ensure that any unbalance does not become excessive and result in equipment ratings being exceeded.
- Discharge of the MMC submodule capacitors caused by a DC fault can be prevented by blocking the converter.

5.6.8.2.6 Harmonic coupling of different MMC substations connected to one DC circuit

Between the submodule capacitors of different substations, there are some semiconductor devices. So harmonic coupling is less serious for the MMC VSC systems than that of 2-level or NPC VSC systems.

5.6.9 DC reactor

For long-distance transmission, a DC reactor can be connected in series with a DC overhead transmission line or cable. Its main purpose is to reduce harmonic currents flowing in the DC line or cable.

The DC reactor also serves a secondary function in limiting short-circuit currents.

If a DC reactor is used in a VSC transmission system, its size can normally be considerably smaller than one used in an LCC HVDC scheme.

5.6.10 DC filter

Filtering of harmonics on the DC side is achieved by the VSC DC capacitor, DC reactor, common-mode blocking reactor and, in some cases, by a dedicated DC filter.

The design principles of the DC filters for VSC-based HVDC systems are similar to those for LCC HVDC systems, as described in [5].

5.6.11 Dynamic braking system

In some VSC HVDC schemes, but particularly where the HVDC system is exporting power from a small islanded AC system with little or no load (for example an offshore wind farm), the HVDC system can be required to include a dynamic braking system, for example as a chopper connected to the DC terminals of the VSC system. The function of the dynamic braking system is to absorb and dissipate the power generated in the islanded AC system during faults in the receiving-end AC system, typically for durations of 1 s to 2 s.

There are several possible ways of implementing such a dynamic braking system but the valves in this system will, in general, be of similar design to the main VSC valves used for power transmission.

6 Overview of VSC controls

6.1 General

Although there are many configurations for voltage sourced converters (VSCs), they all can be considered to exhibit a common operating concept. All configurations possess a series inductive interface separating the switching valves from the AC system. The switching valves generate a fundamental frequency AC voltage from a DC voltage. The magnitude and phase of the fundamental frequency component of this AC voltage at the valve side of the series inductive interface can be controlled. The control of this voltage magnitude and phase is the essential controlling function common to all VSCs.

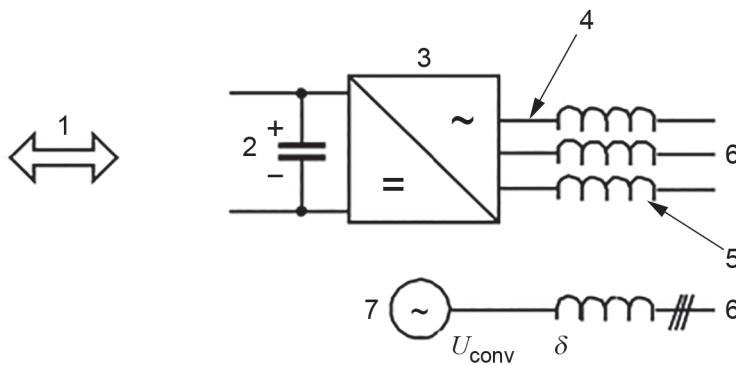

IEC

Key

- | | | | |
|---|--|---|--|
| 1 | active power | 5 | phase reactor and/or interface transformer |
| 2 | DC side | 6 | AC side |
| 3 | voltage sourced converter | 7 | equivalent representation of a VSC as a voltage behind an inductance |
| 4 | point of phase and magnitude control of AC voltage | | |

Figure 25 – Representing a VSC unit as an AC voltage of magnitude U and phase angle δ behind reactance

Figure 25 shows that a VSC can be represented as an AC voltage source of magnitude U_{conv} and phase angle δ behind the reactance. If the per-unit voltage U_{conv} is higher than the per-unit line side voltage U_L , then reactive power will be transferred into the line side similarly to an overexcited synchronous machine. Conversely, if the per-unit value of U_{conv} is low and less than the per-unit value of U_L , the VSC will be absorbing reactive power similarly to an under-excited synchronous machine.

The control of the phase angle δ is achieved by shifting the phase of the fundamental frequency AC voltage with respect to the phase locked loop normally synchronized to the AC side voltage. Regulating the phase angle δ causes active power to be transferred through the VSC, because a phase angle in fundamental frequency voltage is developed across the interface reactor so that power flows into or out of the VSC.

A VSC therefore has the capability of acting as a rectifier or as an inverter, and/or as a generator or an absorber of reactive power. It is the control of the magnitude and phase of the converter voltage U_{conv} that dictates the strategies for controlling voltage sourced converters.

6.2 Operational modes and operational options

The DC side capacitor voltage is varied by pumping power from the AC side into it or out of it. If power is pumped into the capacitor, its charge will increase and consequently so will its voltage. If power is taken from the capacitor, its voltage will decrease. Power can be taken from or fed into the AC side by varying the phase angle δ , as described above. In this way, DC voltage control is achieved by regulating AC phase angle δ .

Control of the magnitude and phase of the converter voltage U_{conv} for VSC transmission applications is usually achieved by means of vector control strategy. With vector control, three-phase currents are transformed to d and q axis quantities based on the conventional abc to dq transformation, synchronized to the AC side three-phase voltage through a phase locked loop (PLL). The d and q axis voltages generated by the vector controls are transformed to three-phase quantities and converted into line voltages by the VSC as shown in Figure 26.

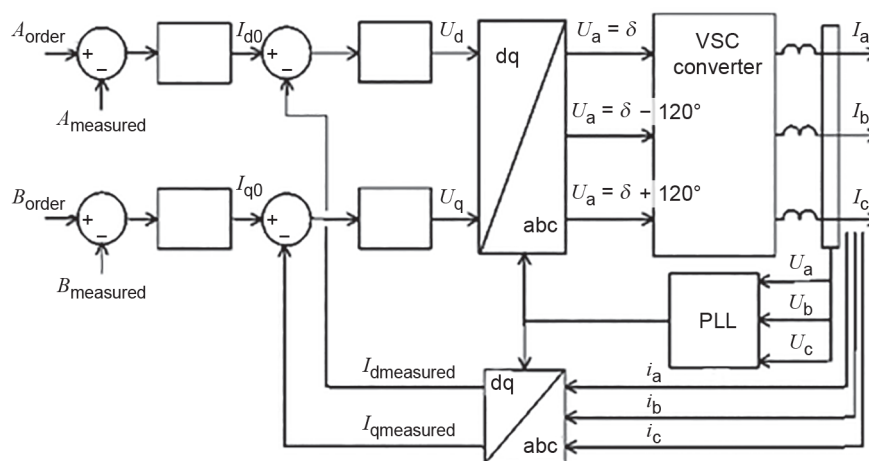

IEC

Figure 26 – Concept of vector control

With VSC converters, the degrees of freedom available are as follows:

- frequency control by direct control of the main firing oscillator;
- the various control options provided by phase shifting the AC voltage that is generated by the VSC;
- the various control options provided by control of the magnitude of the AC voltage that is generated by the VSC.

These degrees of freedom translate into the various control functions discussed below.

6.3 Power transfer

6.3.1 General

To control power into or out of the AC system, the VSC needs to have a means for transferring power into or out of the DC side without over- or under-charging the capacitor. In a VSC transmission scheme, this means that the converters at the two ends of the scheme are controlled to work together. Generally, one of the two converters will have as part of its objective the control of the DC voltage.

Power control is achieved by regulating the phase angle δ of the fundamental frequency component of the AC voltage at the converter side of the interface reactance as shown in Figure 27. Power is drawn from or pushed into the AC system depending on whether δ lags or leads the phase angle of AC bus voltage.

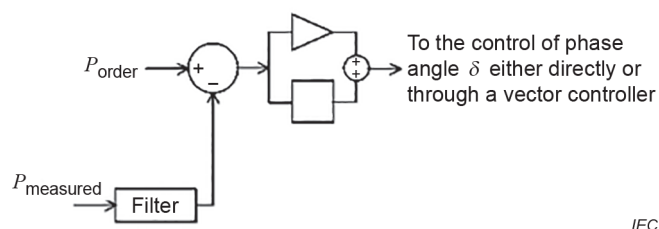

Figure 27 – VSC power controller

Power is one parameter that can be controlled with fast response to improve the performance of the AC transmission system under transient conditions. This can be used to increase AC system damping of electromechanical oscillations, as well as to improve the transient stability of the power system following a fault.

6.3.2 Telecommunication between converter stations

For VSC transmission control, there is no need for fast telecommunication signals between the ends. However, telecommunications between the converters can be applied for conditions such as the following:

- when power control is required between converters for a multi-terminal configuration, such as for coordinated damping of electromechanical oscillations;
- when damping of electromechanical oscillations is required at the converter that is not controlling power;
- if it is desired to reconfigure the control modes between converters.

The normal use of communication is however between the converter stations and dispatch centre which requires indications, status signals and alarms for operation of the system.

6.4 Reactive power and AC voltage control

6.4.1 AC voltage control

AC voltage control is achieved by regulating the magnitude of the fundamental frequency component of the AC voltage generated at the VSC side of the interface reactor and/or transformer as shown in Figure 28.

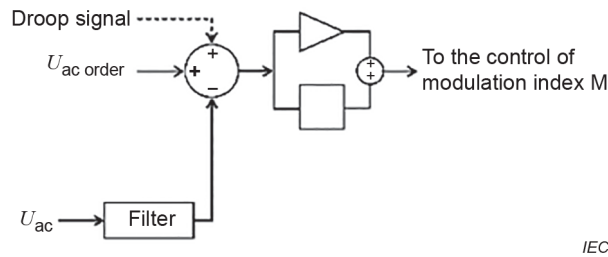

Figure 28 – AC voltage controller

If the VSC is feeding into an isolated AC system with no other form of active power source of any significance, the AC voltage controller will automatically control power to the load. This assumes another converter, such as the sending end of a VSC transmission link, independently controls the DC side voltage.

6.4.2 Reactive power control

The need to use reactive power control arises when other nearby controllers are acting to maintain AC voltage. To avoid interference between the various controllers, it is preferable to retain those VSCs not needed for AC voltage to provide reactive power control.

If all VSCs in close proximity to each other are controlling the same quantities, then it can be possible for each to participate in AC voltage control through a carefully designed droop characteristic. However, if the controlling functions of the VSC are quite different, such as separate and independent power controllers, the droop characteristic can be difficult to define. Under these circumstances, a reactive power control can be preferable, with the settings either at zero MVARs or slowly controlled by a joint VAR controller or an order from the SCADA system.

6.5 Black start capability

To supply an AC load that has no other source of generation, the rectifier connected to the main grid or generation can have the following controls:

- DC voltage control;
- AC voltage or reactive power control at the sending end system.

The receiving end needs to have controls as follows:

- frequency control (defining the frequency of the load);
- AC voltage control of the receiving end system.

With these control modes in place, the load-side AC voltage and frequency can be controlled within acceptable limits. As the load changes, the transmission self-regulates the power flow simply by maintaining AC voltage and frequency.

If an AC synchronous generator or an AC transmission line is added or switched on-line so that the VSC transmission is relieved of providing the frequency control and all the AC voltage control to the load, the firing pulses can be switched from an independent clock to being phase locked onto the AC voltage. Alternatively, a droop characteristic for the frequency control and the AC voltage control can be invoked so that the VSC transmission can operate in concert with the active system that the receiving end has changed to.

6.6 Supply from a wind farm

DC transmission is sometimes used to export power from an isolated wind farm to an AC grid. This technology can be particularly applicable for offshore wind farms. This is an important and fast-growing use of VSC transmission, which is described in detail in [6].

At the sending end, the VSC converter controls the AC voltage and frequency of the system. The converter at the AC grid side transfers the incoming DC power to the AC grid. The AC grid is usually strong enough to accept fluctuating wind farm infeed.

One important aspect is how to handle energy surplus in case there is a temporary network disturbance where the AC grid is unable to absorb the energy from the wind farm.

Alternatives to handle this energy surplus include to store the surplus energy in the wind turbine by temporarily increasing rotor speed or to dissipate the energy via resistors, for example

- in the wind turbine itself,
- on the offshore AC grid, or
- on the DC side of the VSC transmission, via a dynamic braking system.

7 Steady-state operation

7.1 Steady-state capability

The VSC can be considered as an equivalent of a synchronous machine, which has the capability of individually controlling active and reactive power, albeit normally with limited inertia.

The active and reactive power can be controlled simultaneously and independently of each other as described in 6.3 and 6.4.

The PQ capability diagram of a VSC shows its possible operating regime. The diagram normally gives the capability at the AC interface point. When active output power P is positive, the VSC is operated as an inverter, either in capacitive mode, when Q is positive, or in inductive mode when Q is negative. When P is negative, the VSC is operated as a rectifier, either in capacitive or inductive mode. A simplified PQ diagram at minimum (U_{\min}) and maximum (U_{\max}) AC grid voltage, in which filters are not considered, is shown in Figure 29. The VSC can be operated within all four quadrants of the PQ plane.

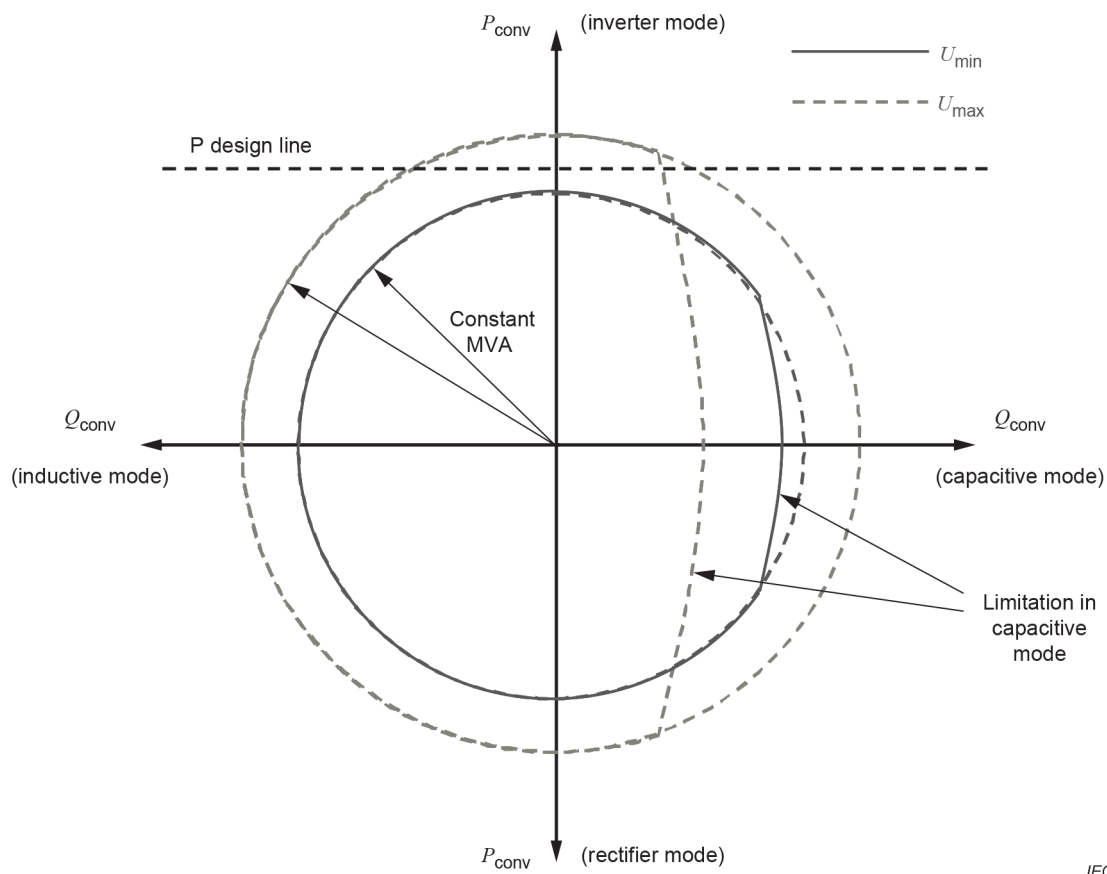

Figure 29 – A typical simplified PQ diagram

The PQ diagram shows that the capability of the VSC depends on the AC grid voltage. At low AC voltage, a higher current is necessary to produce a given output power, and the output capability is limited by the current capability of the converter. Therefore, if an interface transformer is provided, the transformer ratio can be used to optimize the PQ characteristic. With an on-load tap changer, the transformer ratio can be continuously optimized to maximize the steady-state power capability of the converter. Note that the centre of the circles is dependent on the design of the converter, and might not be at the origin of the diagram.

The diagram also indicates an active and a reactive power design line. The design line is the maximum power rating of the VSC and it is mainly determined by the maximum current for which the converter is designed. In addition to the limitation by the maximum converter current, there might be other design limitations, for example affecting reactive power capability. In capacitive mode, the peak converter AC voltage U_{conv} needs to exceed the peak line-side AC voltage U_L ; however, U_{conv} generally cannot exceed $0,5 U_d$. Therefore, the capacitive output rating is limited, particularly at high values of U_L . The active power design line in the PQ diagram indicates the desired rated power of the VSC. In the example shown, the required power capability in inverter operation is less than the potential capability of the VSC.

7.2 Converter power losses

One of the main obstacles to using voltage sourced converters in bulk power transmission is the comparatively high power losses, including IGBT, filter and interface transformer losses, in comparison with LCC HVDC. However, VSC technology is developing rapidly and power losses are decreasing.

The 2-level VSC topology is attractive because of its simplicity. However, the switching frequency chosen is usually comparatively high in order to keep the current ripple reasonably low, and this will result in high switching losses. One way of reducing the losses is to use

more advanced converter topologies, but at the expense of greater complexity. The on-going semiconductor device development and converter topology optimization will contribute to a further reduction in overall losses in the future.

In common with LCC-HVDC, it is recommended that power losses in VSC be determined by a combination of calculation and factory measurement, rather than direct measurement on site.

For most equipment, the overall principles are the same as described in IEC 61803 [7] for LCC-HVDC, although adjustments need to be made to reflect, for example, differences of harmonic spectra. For converter valve losses, IEC 62751 (all parts) [8] is used instead of IEC 61803 (see also [9], [10]).

The power losses in the VSC substation depend on a variety of operating conditions, but chiefly the real transmitted power and the reactive power absorption or generation. In general, losses in the VSC substation will be lowest when the real and reactive power are both close to zero and will increase progressively as either the real or reactive power is increased.

8 Dynamic performance

8.1 AC system disturbances

Fast control of active and reactive power of VSC systems can improve power grid dynamic performance under disturbances. For example, if a severe disturbance threatens system transient stability, fast power run-back and even instant power reversal control functions can be used to help maintain synchronized power grid operation. VSC systems can also provide effective damping to mitigate electromechanical oscillations by active and reactive power modulation.

A VSC system can support the network during disturbances in the following ways:

- emergency power control;
- voltage support;
- short-circuit current contribution.

The ability of the VSC converter to rapidly control active power makes it a tool for emergency power support during network disturbances where power can be transferred to/from the disturbed area in a controlled way. This is also possible with LCC HVDC but VSC HVDC has better possibility to rapidly reverse power.

The VSC converter can operate as a local STATCOM with possibilities for fast voltage support. This can be used to support the connected AC network during a fault or disturbance where the AC voltage drop can be limited by the converter.

The short-circuit power contribution from a VSC converter can be controlled. In systems where the short-circuit currents are already high, there is a large benefit in a low contribution. In systems fed solely by the VSC converter, higher short-circuit currents are desirable in order to have the standard overcurrent protections in the AC network operating as normal. The maximum short-circuit current is normally limited by the dynamic limitations of the converter which are equal to or higher than rated current.

8.2 DC system disturbances

8.2.1 DC cable fault

Mechanism: cable or junction failure, external mechanical stress.

Type: permanent fault, for which repair is needed.

Detected by: DC cable faults are detected by measuring the DC voltage and current, both amplitude and rate of change.

Protective actions: since any fault in a cable needs to be thoroughly investigated and will most likely require a lengthy repair, the DC link needs to be tripped when such faults are detected. It is therefore very important to correctly detect these faults.

8.2.2 DC overhead line fault

Mechanism: insulation failure between one DC conductor and ground or between the two DC conductors, due to lightning strike, brushfires, trees, pollution, external mechanical stress, etc.

Type: can be a non-permanent fault, but can be permanent if the DC insulators have been damaged.

Detected by: DC overhead line faults are detected by measuring the DC voltage and current, both amplitude and rate of change.

Protective actions: it is noted that when insulation breaks down on overhead transmission lines, the VSC's free-wheeling diodes normally continue to feed current into the fault even if the converter is blocked. This means that besides blocking the converters, they normally also need to be isolated from the AC system by opening the AC breakers, to enable the air insulation to de-ionize. After this, re-starting the system can take a time of a few seconds, for example 2 s to 4 s. Another method is to introduce DC breakers and open these when a fault is detected, or to use a special VSC topology which gives an inherent capability to clear DC line faults (see 5.3.3).

8.3 Internal faults

VSC systems are designed, where practical, to permit operation of the rest of the system to continue in the presence of internal faults within one converter station.

A typical protection diagram for a VSC substation is shown in Figure 30; however, VSC substation protection against internal faults will differ depending on the VSC design and protection philosophy. Therefore, the protection system shown in Figure 30 is only representative.

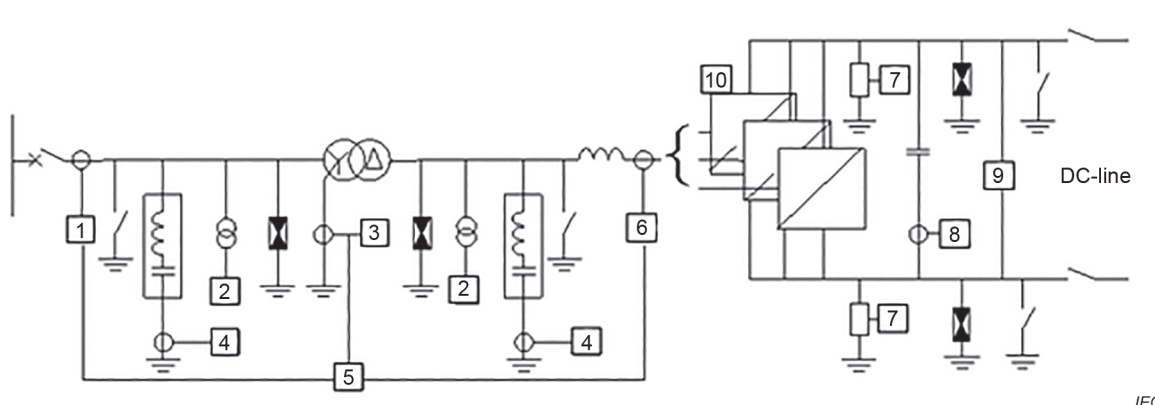

Figure 30 – Protection concept of a VSC substation

Typical protective functions include the following:

- a) overcurrent protection of AC circuit breakers;
- b) abnormal AC voltage protection;
- c) earth fault protection;

- d) AC filter protections;
- e) differential protection;
- f) overcurrent protection of the converter;
- g) abnormal DC voltage protection;
- h) overcurrent protection of the VSC DC capacitors;
- i) DC discharge unit;
- j) valve protection, for example in the valve gate electronics.

Depending on the VSC substation design and the application, the following additional protections are usually applicable:

- k) loss of cooling protection;
- l) DC line/cable earth fault protection/supervision;
- m) frequency protection;
- n) impedance relay protection;
- o) fire protection;
- p) mechanical protection.

9 HVDC performance requirements

9.1 Harmonic performance

Many aspects of the harmonic performance of a VSC transmission scheme are similar to those of an LCC HVDC scheme, as described in IEC TR 62001-1 [4] and IEC TR 62001-5 [11]. The main difference between the two comes from the different switching strategies used in the different types of converter. Different VSC topologies also have widely differing harmonic performance.

In common with LCC converters, the interaction of VSC converters with the network is quite complex and, for an accurate calculation, the pre-existing (background) harmonics on the AC network need to be taken into account and the network impedance at harmonic frequencies is very important. Pre-existing harmonics can be damped or amplified due to operation of the VSC. In order to perform these calculations, accurate information about background harmonic distortion and network impedances for the frequency range of interest is necessary. More guidance on these topics can be found in IEC TR 62001 (all parts) [12].

VSCs generate harmonics on both the AC and DC sides. Measures need to be taken to limit the amplitude of the harmonics entering the AC network and the DC line. The main methods of reducing the harmonics to acceptable levels are as follows:

- pulse width modulation (PWM) techniques;
- multi-level techniques;
- harmonic filters (series and/or shunt combinations);
- multi-pulse (12-pulse, 24-pulse, etc) techniques;
- combinations of the above.

Since a VSC can operate at any desired power factor, the design of the filters is normally based only on harmonic performance and (unlike for LCC HVDC) is not affected by reactive power considerations. Some multi-level converter topologies can generate sufficiently low levels of harmonics that harmonic filters can in some cases be omitted.

9.2 Wave distortion

The individual voltage distortion factor (D_n), total harmonic distortion (THD), telephone harmonic form factor (THFF), telephone influence factor (TIF) and total harmonic current factor (IT), as defined in IEC TR 62001-1 [4], are relevant also to VSC transmission schemes.

It is noted that, with VSC technology, it is relatively easy to shift the spectrum of harmonics to higher orders of the fundamental frequency. When setting the distortion limits for a VSC transmission scheme, it can be appropriate to assess harmonics to a higher order than has been the case for LCC HVDC schemes, for example to increase the order to be included from the 50th harmonic to, for example, the 100th harmonic.

It also needs to be noted that the accuracy of modelling of harmonic impedance decreases at such high frequencies.

9.3 Fundamental and harmonics

9.3.1 Three-phase 2-level VSC

Single-phase AC output for a 2-level converter is shown in Figure 16.

The AC wave shape at a VSC phase unit output can consist of a sequence of square waves, as shown in Figure 31. Many different modulation methods can be used to control the converters to achieve a specific wave shape. The most commonly used method is the carrier-modulated method (voltage reference as sine wave or other with a triangular carrier wave shape). Some typical modulation strategies used with 2-level VSC are discussed in Annex B.

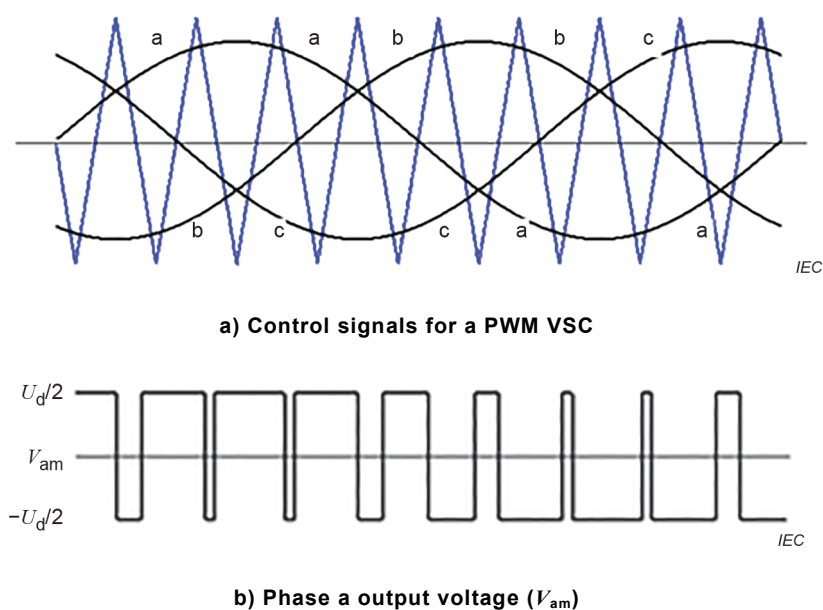

Figure 31 – Waveforms for three-phase 2-level VSC

9.3.2 Multi-pulse and multi-level converters

Multi-pulse and multi-level converter topologies can also be used to reduce the harmonic output. The harmonics are calculated by Fourier analysis of the individual waveforms.

The individual levels of such converters are switched to obtain desired output voltage at the AC and DC terminals of the converters. The methods for switching individual levels can be distinguished in two main categories:

- methods resulting in a random type pulse pattern;

- methods creating a fixed pulse pattern (for given output voltages).

Random type pulse patterns distribute the harmonic distortion over the full frequency range, resulting in a "white noise" with moderate amplitudes. Due to their random nature, these harmonics are not easy to predict on a pure analytical basis. In contrast, fixed pulse patterns can be easily predicted and analysed.

9.4 Harmonic voltages on power systems due to VSC operation

One possible method for calculating the harmonic performance of the VSC is to consider it to be a harmonic generator of equivalent voltage E_n at each individual harmonic. At the point of common connection (PCC) of the VSC and the power system, the equivalent circuit is shown in Figure 32, where $Z_{S(n)}$ is the system impedance at the harmonic n and $Z_{(n)}$ is the harmonic impedance of the VSC, including the interface transformer, phase reactor and AC filters (as appropriate). If shunt filters are used either as part of the network or as part of the converter, they are included in respective impedance.

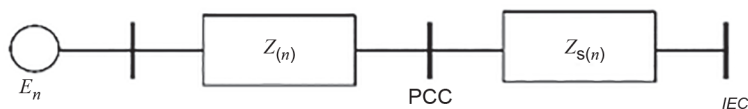

Figure 32 – Equivalent circuit at the PCC of the VSC

Since both $Z_{(n)}$ and $Z_{S(n)}$ are a complex impedance, a resonance can occur. Therefore, it is essential to have knowledge of the purchaser harmonic system impedance at the PCC.

9.5 Design considerations for harmonic filters (AC side)

If the evaluation indicates that the VSC contribution to harmonics at the PCC will exceed the permissible level, harmonic filters need to be designed and installed to keep the harmonics within the required limits. The filter configuration for the VSC is determined in a similar manner as those for LCC HVDC; see IEC TR 62001 (all parts). However, one important difference is that the VSC behaves as a harmonic voltage source on the AC side, and hence the series filtering action of the phase reactor and associated equipment is more important than the effects of any shunt filters.

9.6 DC side filtering

If the VSC is part of a DC transmission scheme connected by a DC overhead line, or a combination of DC cable and DC overhead line, its DC-side harmonics can interfere with other equipment and substations near the transmission line. VSC systems frequently use land cables which can be installed in trenches alongside telecommunication cables. If there are copper telecommunication cables close to DC cables over a long distance, the potential interference between these cables is usually considered. The frequencies used in commercial voice transmission range from 200 Hz to 3 500 Hz. Telephone noise evaluation is performed according to various weighting factors (such as CCITT and BTSEEI) according to local practices. The coupling between power circuits and telephone circuits is through both electric and magnetic fields. However, unless the spacing between the two circuits is small, the magnetic coupling predominates and the electric coupling is negligible. For bipolar DC lines, this coupling is usually calculated using the "equivalent disturbing current" [5].

If filtering is required on the DC side, a common mode reactor, DC reactor, or a DC filter can also be used to perform the role of RF filtering.

10 Environmental impact

10.1 General

Clause 10 covers the main environmental impact resulting from the development of a VSC substation. The environmental aspects discussed are audible noise, visual impact, EMF and EMC. Other factors of a more generic character that result from VSC substation development are not covered, nor are the impacts from the development of a cable or overhead line system. End-of-life issues like recycling and disposal are similar to those for an LCC HVDC scheme, as are power losses.

10.2 Audible noise

IEC TS 61973 [13] covers in a comprehensive manner the audible noise related to line commutated HVDC converter stations, and is applicable also to VSC transmission. Audible noise theory is, therefore, not covered here.

The noise characteristics of the cooling equipment and auxiliaries are similar to those used in a conventional AC substation. Dependent on the converter topology used, the noise characteristics of the transformer can be similar to those of a substation transformer, as the use of filters on the converter side results in a very low level of harmonics in the transformer. For some converter designs, the noise characteristics can be different. For converters using valves of the switch-type, the filters, VSC valves, phase reactor and VSC DC capacitors typically have noise components at higher frequency than for an LCC HVDC scheme. For converters using valves of the controllable voltage source type, the noise spectrum can have a significant component at fundamental frequency, with higher harmonics being more characteristic of "white noise".

Noise attenuation can be achieved by a number of reduction measures that can be incorporated into the design of a VSC station. For many components, such as transformers, cooling equipment and auxiliaries, the measures taken to reduce noise are similar to those for a conventional AC substation.

10.3 Electric and magnetic fields (EMF)

The electric and magnetic fields (EMF) associated with a VSC scheme can be separated into AC and DC fields. The AC fields are produced by the AC components of the substation, and the connection between the VSC and the AC grid. The DC fields (also referred to as static fields) are produced by the cable/OH line, by connections to the DC equipment, and by the DC equipment itself.

In general, the electric and magnetic fields around a VSC facility, including the substation, connections and DC overhead line or cable, are similar to those for an LCC HVDC scheme.

10.4 Electromagnetic compatibility (EMC)

The operation of high-voltage electrical equipment can generate electromagnetic fields over a wide range of frequencies, from power frequencies to television frequencies. It is possible for electrical or electronic equipment in the vicinity of such electromagnetic fields to be affected, or to have their proper operation interfered with. Interference limits imposed on facilities typically consider

- radio interference (RI),
- television interference (TVI),
- telephone interference (see Clause 9), and
- power line carrier interference (see Clause 9).

VSC valve switching can generate high frequency emissions up to several hundred MHz. The VSC design usually ensures that such noise does not cause unacceptable interference for

others. Different mitigation methods can be employed, such as proper grounding, the use of passive radio interference filters, and shielding of the sources by EMC barriers.

Radio interference is associated with noise in the frequency range of 150 kHz to several hundred MHz. Television interference, on the other hand, results from noise in the frequency range 54 MHz to 1 GHz. Consequently, the whole frequency range up to 1 GHz needs to be taken into account when designing the VSC substation.

Electrical interference and noise are transmitted in three forms: radiated, conducted and electro-magnetically induced. For the VSC, conduction on power lines is a more significant source than radiation. Housing a VSC in a metal enclosure or valve hall generally reduces the radiated component of disturbances.

The conducted phenomena consist of two categories, commonly known as the differential mode and the common mode. The differential-mode disturbance is a current or a voltage measured between the power lines of the VSC, while the common-mode is a current or a voltage measured between the power lines and ground. Any filter design needs to take into account both modes of noise.

The path of the common-mode disturbance is through stray capacitance. These stray capacitances exist between any system components and ground. In close proximity to the source, other predominant coupling paths are usually considered, such as electric fields (high impedance field) and/or magnetic fields (low impedance field). Except in far field conditions, one of these will be predominant.

A proper design of a VSC valve and converter layout can reduce the disturbance emissions at their source. In addition, it can be necessary to use filters. Emission level can be assessed by simulation and measurement in-situ.

IEC 61000 (all parts) [14] on electromagnetic compatibility covers emission and immunity for phenomena in the 0 GHz to 400 GHz frequency range. This range is split into several frequency bands, according to measurement techniques.

11 Testing and commissioning

11.1 General

Clause 11 provides general guidelines for testing and commissioning of VSC transmission systems. Emphasis has been put on subsystem and system tests rather than those for components.

Testing and commissioning are part of a process that begins in the factory and ends with the handing over of the equipment for commercial operation. There are two distinct phases: factory or off-site testing, and commissioning testing. Off-site testing is usually performed to prove that equipment, including the control system, meets the design criteria. Commissioning tests are performed after the equipment has been delivered to the site and installed. The tests are organized to test subsystems, systems and overall performance.

As a general rule, all parties involved in the project needs to be included in the tests and all responsibilities clearly defined.

General requirements for system testing are described in [15].

11.2 Factory tests

11.2.1 Component tests

These tests concern the verification of the single components, including control and protection equipment, before they are sent to site. They can be subdivided into routine tests, aimed essentially at quality control, and type tests which verify that a component has been properly designed to sustain the stresses from potential transients and service conditions. Factory testing of VSC converter valves is covered by IEC 62501 [16]. Traditional components such as switchgear, transformers, capacitors, capacitor fuses, reactors, resistors, insulators, voltage and current transformers, surge arresters, etc, are covered by [3], in which the available standards (IEC, IEEE, ANSI) are pointed out and the special tests are introduced.

11.2.2 Control system tests

As with the controls for LCC HVDC systems, the control system for a VSC transmission system, including hardware, software and documentation, can be tested and verified in a factory system test (FST). A real time simulator will be required that can represent power components and parts of the AC system in a sufficiently detailed way. Every effort is usually made to test as complete a system as practical, including redundancy, so as to minimize work on site. Factory system testing is an extensive and thorough check of the control and protection system under normal and fault conditions, without the constraints imposed by the real system. Selected on-site system tests will repeat some of the factory system tests, but will include the actual transducers and main circuit equipment, as well as actual system conditions (as permitted within system constraints). All software and hardware functions, including redundancies, are usually tested before the equipment is shipped to site for installation and commissioning.

Besides simulator tests identical to those for LCC HVDC, other tests need to be considered that account for the additional modes of operation possible with a VSC. Each mode is usually tested both in the factory and during commissioning (e.g., operation of the converter as a STATCOM, black start capabilities, and feeding a passive network). The results obtained from real time simulator tests and system studies (in particular the dynamic performances studies) are the main references used to define the commissioning plan and validate the test results in the field.

11.3 Commissioning tests/system tests

11.3.1 General

Commissioning tests are organized in a succession of phases.

The first phase is the so-called "precommissioning tests" executed on single station components in order to check their condition and functionality after transport and assembly. This phase is followed by the "subsystem tests," which test several components working together to perform a specific function. These are followed by the "system tests," which involve all converter stations and full power transmission. The system tests require careful coordination between all interested parties, in particular the system operators, utilities and industrial customers that could be affected by the tests.

During inspection and testing, all applicable health, safety and environmental requirements and regulations need to be followed. Any deviations are discussed and resolved at site meetings. Often there is an overlap between commissioning and installation, especially in the area of cable termination. Care needs to be taken when interconnected subsystems are energized and started up that personnel are notified so that no potentially hazardous conditions exist. For an efficient process, it is important to complete as many as possible of the equipment pre-commissioning checks before energization of the equipment. Most utilities have extensive safety rules that protect workers from accidental electrical contact.

11.3.2 Precommissioning tests

Precommissioning consists mainly of inspection and equipment tests. Equipment tests include electrical and mechanical tests and simple functional tests confined to a single installed unit. The purpose of these tests is to check the condition of the equipment and verify proper installation. If normal auxiliary power is not yet available, electrical tests can be performed with portable or temporary power supplies. At this stage, settings are verified in protection and control equipment.

In those cases where disconnection and reconnection would be required for the equipment tests, precommissioning tests on main circuit equipment are performed before the main conductors are connected. Equipment tests are performed as soon as possible after installation, and according to the manufacturer's recommendations.

11.3.3 Subsystem tests

Subsystem tests verify the proper operation of a group of interconnected or related equipment. Subsystem testing needs to be done in stages from small to progressively larger subsystems, and to check as many functions as possible.

Typical subsystem tests are

- subsystem functional testing,
- start-up of auxiliary systems, and
- low-voltage energization.

11.3.4 System tests

11.3.4.1 General

The system tests involve operating the converter(s) in conjunction with the interconnected AC transmission system. These tests are not only checked for proper performance of the automatic controls during normal changes in references, set points or operating modes, but also take place, in so far as possible, under different network conditions. System tests need also to include selected disturbances to verify dynamic performance and robustness. Disturbances can consist of nearby capacitor bank switching, transformer energization, line switching, generator tripping, step responses, or even staged faults where specified, and cover the most critical conditions evidenced by the system studies and by simulator tests, in so far as the networks allow. Some tests with high potential impact can require special provisions to mitigate the possible adverse system impact of large reactive/active power variations. These will require tight coordination with the transmission system operator (TSO)/utilities of AC networks to which the VSC transmission system is connected.

Usually, tests with lower impact on AC networks are performed first, followed by the more onerous ones.

11.3.4.2 High-voltage energization

When all prerequisites for high-voltage energization have been completed, operational authority is transferred to system operators to ensure that all safety rules are followed and that any system constraints are observed. Operational procedures need to be formalized beforehand. High-voltage energization is preceded by final trip tests and "dry run" tests where the operators execute the procedure without actually energizing the equipment.

Energization of AC equipment follows a step-by-step sequence for the AC buses, bays, filters and transformers. This can require temporary disconnection of some high-voltage terminations where disconnect switches are not provided. Equipment is initially energized for several hours. Checks are made for corona and any abnormal audible noise. Phasing and phase rotation are rechecked with full voltage. During filter energization, unbalance

protections are checked and load checks are made. Visual inspections of all equipment and surge arrester counters are made before and after energization.

Energization of the converter and DC equipment follows that of the AC equipment. In most cases, valve cooling needs to be running before energizing the converter. With the VSC, the connected DC side equipment (i.e., DC buswork, DC capacitors and DC transducers) is energized through the valve anti-parallel diodes when the main AC breaker is closed thereby energizing the converter.

As an additional check, the converter can be energized via the DC side, with the AC connection open. A special DC power supply could be provided for this purpose, or the converter at the opposite end of the link could be used as a rectifier to provide this function.

During energization, DC voltage measurements and status signals from individual semiconductor positions are checked via the valve monitoring.

If other converters or DC cables are included in the particular application, they are initially energized separately while isolated from the other converter(s) and interconnecting cables or buswork.

11.3.4.3 Converter operating tests

11.3.4.3.1 General

Once the converter and DC equipment have been energized and checked out, the converter can be deblocked, sending switching pulses to the valves. Initially, this is performed one converter at a time, with the VSC operated in AC voltage control or reactive power control. The purpose of the converter operational tests is to check that the converter operates properly with the AC network.

During converter operational testing all subsystems, for example controls, transducers, auxiliaries and main circuit equipment, are tested together for the first time.

Typical tests performed during converter operation are explained in 11.3.4.3.2 to 11.3.4.3.8.

11.3.4.3.2 Sequences

It is checked that breakers, disconnects and deblock/block and trip sequences operate properly in response to manual, automatic or protective orders. Check that the initial operating condition is neutral, minimizing the disturbance to the network, for example automatic connection of filters, if any, with net zero reactive power exchange through counterbalancing VSC absorption.

11.3.4.3.3 DC voltage control

It is checked that the DC voltage is controlled to its reference voltage, and that all levels of DC voltages are balanced.

11.3.4.3.4 Measurements

It is checked that all controls, indications and measurements have correct polarity, phase and scaling. Take selected measurements of AC and DC harmonics and distortion.

NOTE Final measurements are usually reserved for acceptance tests.

11.3.4.3.5 Reactive power control

It is checked that the reactive power control, if relevant, follows the reference at the selected ramp rate for both inductive and capacitive ranges. Check proper converter reactive power limitations.

NOTE Operating restrictions on AC voltage can limit the amount of reactive power that can be exchanged with the AC network.

11.3.4.3.6 AC voltage control

It is checked that the voltage is controlled to the reference, if relevant, and that the reactive power is stable. Vary slope, reference, deadband and voltage control modes, as provided. Check stability with the AC network by reference step response, capacitor bank switching and/or AC line switching.

11.3.4.3.7 Load test

The capability of the cooling equipment is checked, primarily for the VSC valves. Observe the temperatures and sequencing of the cooling equipment as the load is increased.

Operating restrictions on AC voltage can limit the amount of reactive power that can be exchanged with the AC network, and special provisions need then to be made to reach full output.

11.3.4.3.8 Disturbance tests

In addition to the testing of the step responses to regulator references, the converter and its controls are tested for various internal disturbances (e.g., auxiliary supply changeover, control system changeover, and external disturbances in the AC transmission system) to verify proper performance, stability and robustness. External disturbances can consist of switching nearby capacitor banks, transformers, transmission lines, or tripping generators.

11.3.4.4 Transmission tests

11.3.4.4.1 General

Transmission tests involve operation of converters that work together to control the power flow. Such testing requires a very high degree of coordination with the system operator (dispatcher).

Typical tests performed during transmission testing are as described in 11.3.4.4.2 to 11.3.4.4.11.

11.3.4.4.2 Sequences

It is checked that breakers, disconnects and deblock/block and trip sequences operate properly in response to manual, automatic or protective orders. It is checked that the initial operating condition is neutral, minimizing the disturbance to the network, for example zero net reactive or active power exchange.

11.3.4.4.3 DC voltage control

High-voltage DC cables, bus work or lines interconnecting the converters are energized. It is repeated with the other converter connected. Depending on application and protective strategy, it is checked that the DC voltage is controlled to a reference during power transfer and blocking/tripping of one of the other converters.

11.3.4.4.4 Power control

It is checked that the power flow and power ramp rate follow the reference values. The power control stability by step response or system disturbance is checked, such as line switching. Transmission in both directions is checked. Proper converter real power limitations are checked.

11.3.4.4.5 Reactive power control

If relevant, the joint operation of the reactive power control and active power control at the different converters is checked by changing their respective references during the different operating modes. Proper converter reactive power limitations are checked.

11.3.4.4.6 AC voltage control

If relevant, the joint operation of the AC voltage control and active power control at the different converters is checked. The stability by step response in the power and voltage references, or during system disturbances such as capacitor bank or line switching is checked.

11.3.4.4.7 Load test

Ramp up to full power transmission or MVA converter rating is done for the different operating modes, as permitted by AC system and other conditions.

11.3.4.4.8 Measurements

Selected measurements of AC and DC harmonics and AC voltage distortion are taken.

NOTE Final measurements are usually reserved for acceptance tests.

11.3.4.4.9 Redundancy checks

If the system is equipped with redundant control and protection systems, transfers from the active to standby system are performed. Transfers between redundant auxiliary systems need also to be checked during operation, for example auxiliary power, cooling pumps.

11.3.4.4.10 Remote control

Operation is tested from remote locations. All remote indications and control functions are checked.

NOTE Much of this work is done beforehand during subsystem testing, but this is the first time that remote system operators have direct control of the system. Previously, operation was from the local level with authorization only from the system operator.

11.3.4.4.11 Disturbance tests

In addition to testing the step responses to regulator references, the converter and its controls are tested again for various external disturbances in the AC transmission system to verify proper performance, stability and robustness. External disturbances can consist of switching nearby capacitor banks, transformers, transmission lines, tripping generators, or even staged faults, for example DC or AC overhead line faults, as relevant.

11.3.4.5 Trial operation

Trial operation allows the owner to operate the integrated system according to its intended purpose from the normal control location. Trial operation does not start until almost all system tests have been successfully completed. During trial operation, observation of the complete system and subsystems takes place. All alarms or abnormal conditions are dealt with as required.

11.3.4.6 Acceptance tests

11.3.4.6.1 General

Acceptance tests verify the performance of the system according to the specification on a selected basis. Acceptance tests can involve measurements to verify that interference levels are within the design limits and that other fundamental performance criteria are met.

11.3.4.6.2 Heat run

The system is operated at rated and overload capacity for specified periods of time in different operating modes, if applicable. Temperatures and cooling systems are monitored. This test usually takes several hours due to the slow heating of the transformers.

11.3.4.6.3 Interference measurements

It is verified that harmonics on the AC and DC sides, audible noise, radio interference, PLC interference, etc., meet the performance requirements.

11.3.4.6.4 Disturbance response

Auxiliary supply changeover, control system changeover, line switching, shunt bank switching, generator tripping or staged faults are tested, as necessary.

Annex A (informative)

Functional specification requirements for VSC transmission systems

A.1 General

Annex A presents the minimum requirements of a functional specification for a VSC transmission system. Once the technical requirements of the VSC transmission system have been defined and confirmed by basic system studies, a functional specification can be prepared. Supplemented by the commercial conditions, the specification allows the purchaser to invite tenders from manufacturers for the equipment required. The functional specification needs to provide adequate information from the purchaser to the manufacturer and the required information exchange between the purchaser, the manufacturers and relevant subcontractors.

The specification usually includes parts where a minimum requirement is specified, as well as those parts where a performance above the minimum standard is desired but not essential. The specification includes a method for evaluating the above-minimum performance criteria.

In Clause A.2, the minimum technical information that needs to be provided by the purchaser and manufacturer are summarized. These summaries describe:

- general requirements of the VSC transmission system;
- power system configuration to which the VSC transmission system is connected, including all the parallel transmission systems, if any;
- requirements of the DC line, i.e., type of cable or overhead line or combination thereof. If the DC line is not within the scope of supply, the converter manufacturer needs to provide information that would be needed for a proper line specification. The type of line chosen is approved by the converter manufacturer as to its applicability;
- site and environment;
- operating function of the VSC;
- maintenance, performance tests and spare parts requirements;
- VSC site, transmission right of way, and environmental constraints and consideration;
- factory and commissioning tests;
- other considerations relating to loss evaluation, tender evaluation, health and safety, and other ancillary requirements.

The purchaser usually provides a detailed description of the power systems connected to the VSC transmission system to enable the suppliers to offer the most suitable and economic equipment design. In addition, the purchaser and the manufacturer usually maintain a continuous dialogue starting at the tender stage and continuing until the project is completed. The manufacturer reviews the basic studies undertaken by the purchaser, and vice versa.

A.2 Purchaser and manufacturer information requirements

A.2.1 General

In A.2.2 and A.2.3, information marked with an asterisk (*) can require detailed studies that might not be available before the contract stage. All information in A.2.2 and A.2.3 not marked with an asterisk (*) is normally provided at the tender stage.

For some parameters, time varying data can be appropriate, for example the range of AC system RMS voltage can include excursions outside a normal range during brief periods (hours, minutes, seconds or milliseconds) with different limits for each duration. Such time varying data need to be described in an appropriate manner.

The confirmation of performance can be demonstrated by any one or a combination of the following methods:

- studies;
- computer simulation;
- tests.

A.2.2 General requirements

Purchaser specification requirement	VSC manufacturer supplied information
Definition of scope of supply	
Location of the VSC	
Role of the VSC	General description of solution
Converter type and DC side configurations (if fixed) <ul style="list-style-type: none"> • Converter type • Topology of DC system • Type of DC line/cable • Transmission voltage (if fixed) 	Confirmation of the VSC type and configuration and DC side configurations
Main ratings of the VSC <ul style="list-style-type: none"> • Power to be transmitted • Locations of real and reactive power reference points • DC voltage and current, if applicable • AC sending and receiving voltages • Frequency of the system • Power resolution 	Guaranteed rating of the VSC
Important ancillary control requirements, e.g., <ul style="list-style-type: none"> • Reactive power regulation requirements • Overload requirements • Transient performance 	Guaranteed performance of the VSC
Requirement on VSC losses <ul style="list-style-type: none"> • Definition of operating point(s) for which losses are to be determined • Capitalized loss evaluation rate 	Losses at designated operating conditions and the method of loss calculation and loss distribution between the major components
Standards and codes	Confirmation of the standards and codes
In service date	<ul style="list-style-type: none"> • Confirmation of the critical dates • Key milestone dates
Tender assessment criteria	
Special premiums applied, e.g., for performance in excess of the minimum requirement	Details of the areas where the minimum required performance is exceeded
Health and safety requirements	

A.2.3 Detailed descriptions

A.2.3.1 Power system configurations

A.2.3.1.1 General

Purchaser specification requirement	VSC manufacturer supplied information
System configuration <ul style="list-style-type: none"> • Single line diagram of the system connection points • Harmonic impedance envelopes seen from the points of connection • Data on nearby generation • Modelling information for nearby controllable devices, such as static VAR (volt-ampere reactive) compensators (SVCs), wind turbines, etc. 	

A.2.3.1.2 DC line/cable (in case of turnkey, supplied by the converter manufacturer)

Purchaser specification requirement	Converter manufacturer supplied information
Main features of DC side <ul style="list-style-type: none"> • Configuration of the DC system • Topology of DC system • Type of DC transmission line (cable or overhead line or a combination thereof) • Length of the overhead line • Length of the cable 	Confirmation of the configuration of the DC system including cable/ overhead line parameters, e.g., <ul style="list-style-type: none"> • current capability, steady state and overload (if any) • voltage withstand capability • proposed type tests including test levels
National safety codes/standards for design of overhead lines and cables	Confirmation of the national safety codes/standards Confirm that design meets the requirements
Information about the overhead line <ul style="list-style-type: none"> • Air temperature range • Wind conditions • Ice loading requirements • Air pollution level • Risk of vandalism 	Confirm that design meets the criteria*
Information about the cable <ul style="list-style-type: none"> • Length of cable • Minimum required depth of burial • Survey data about the subsea/land terrain • Thermal resistivity of soil/silt/seabed • Temperature conditions • Requirement for fibre optic cable (whether embedded or not) 	Confirm that design meets the criteria*
Location of nearby communication cables	Confirm there is no effect on communication cables*

A.2.3.1.3 DC line/cable (not supplied by the converter manufacturer)

Since the design of the converter and the cable are interdependent, the design process will be iterative. Therefore, the data needs to flow between the VSC manufacturer and the cable supplier as shown below.

Purchaser specification requirement	Converter manufacturer supplied information
Provide data from the DC line/cable supplier to the converter manufacturer	<ul style="list-style-type: none"> • Maximum steady-state, dynamic and transient current by the VSC • Maximum steady-state, dynamic and transient voltage by the VSC • Harmonic voltage and current at the VSC terminals caused by the VSC • Overvoltage protection provided • Approval of selected DC line/cable system
Requirement for VSC data for cable manufacturer	Data provided

A.2.3.2 Site and environment

Purchaser specification requirements	Manufacturer supplied information
Space and footprint restrictions	VSC layout and layout options
Site accesses and transports limitations	Access and transport requirements
Electromagnetic field limitations	Electromagnetic field generation
Electromagnetic immunity requirements	Electromagnetic immunity levels*
Requirement for VSC grounding conditions	Requirement of appropriate electrode
Ambient temperature, pressure and humidity ranges	Confirm operation under required conditions*
Solar, snow and ice, wind, air pollution, isokeraunic level and seismic conditions	Confirm operation under required conditions*
Noise restriction, acoustic and electromagnetic telephone interference restrictions	Confirmation of the requirement*
Requirements in respect of earthquake resistance	Confirmation that the design meets the requirement with respect to earthquake resistance*

A.2.3.3 Operating function of the VSC

Purchaser specification requirement	Manufacturer supplied information
Requirement for the main operation <ul style="list-style-type: none"> • Requirement for the transmitted power • Main ancillary operation (if needed) <ul style="list-style-type: none"> – Requirement for the reactive power – Requirement for the AC voltage regulation – Requirement for the DC voltage regulation – Requirement for the control priorities 	Confirm operation ability* including the VSC control modes and control laws
Requirement for the dynamic performance <ul style="list-style-type: none"> • Requirement for the response time for the output change • Requirement for the overload performance 	Confirm operation ability* including short-term overload ratings

Purchaser specification requirement	Manufacturer supplied information
<p>Operation range (Range of conditions over which rated performance or ride-through is required)</p> <ul style="list-style-type: none"> • Range of the AC system conditions in which the VSC needs to operate (both steady state and transient) <ul style="list-style-type: none"> – AC sending and receiving voltage range including temporary overvoltage – AC frequency range – Range of AC voltage imbalance – Zero sequence voltage range – Range of harmonics – Switching transient – Fault level – System configuration • DC conditions 	<p>Confirmation that the system remains operational and description of the performance*</p>
<p>Requirement for protection</p> <ul style="list-style-type: none"> • Faults which are postulated for the VSC to be turned off safely or to ride-through <ul style="list-style-type: none"> – Fault types – Faults levels and clearance times – Whether single- or three-phase auto-reclosure is used and if so, the timing of different periods. • Protection for the AC system • Protection for the DC side • Protection for the VSC 	<p>Confirmation of the requirement, e.g.,</p> <ul style="list-style-type: none"> • performance during faults, other low-voltage conditions and switching transients • control logic and settings for operation during above conditions • description of protection system, including protection against internal failures • worst case internal faults in terms of duration and effect on transmission
<p>Acceptable adverse effect to the power system by the VSC</p> <ul style="list-style-type: none"> • Harmonics • Electromagnetic noise 	<ul style="list-style-type: none"> • Predicted value of harmonics (voltage and current) generated from the VSC • Measured value* of harmonics (voltage and current) generated from the VSC • Individual harmonic distortion D_n^* • Total harmonic distortion THD* • Telephone influence factor TIF*
<p>Requirement for the insulation coordination</p>	<p>Overvoltage withstand capability *</p>
<p>Others</p> <ul style="list-style-type: none"> • Requirement for earthquake resistance • Requirement for salt damage • Reliability <ul style="list-style-type: none"> – Requirement for the lifetime of the VSC – Requirement for the availability – Requirement for the outage rate – Prerequisite condition for the reliability design – Requirement for redundancy • Requirement for the measurements, alarm, and monitoring • Requirement for the interface between the power system and the VSC <ul style="list-style-type: none"> – Main circuit – Control signal • Initial energization and shutdown requirement 	<p>Confirmation of the requirement*, e.g.,</p> <ul style="list-style-type: none"> • Predicted life, reliability and availability characteristics, forced outage rates, maintenance frequency and periods • Failure rate of key components, e.g., semiconductors, DC capacitors • Transient effect of component failure

A.2.3.4 Maintenance and spares

Purchaser specification requirement	Manufacturer supplied information
Maintenance requirement	Maintenance frequency, duration and recommended maintenance
Special maintenance test equipment requirements	Special test equipment provided
Spares requirements	Recommended spares holdings
Drawings, maintenance manuals, technical notes	Description of documentation provided As-built drawings, maintenance manuals and technical notes provided*

A.2.3.5 Factory and commissioning tests

Purchaser specification requirements	Manufacturer supplied information
Test requirements <ul style="list-style-type: none"> • Equipment requiring type test approval • Factory tests • Functional testing of control suites 	Confirmation of the requirement, e.g., <ul style="list-style-type: none"> • type test evidence offered in lieu of new type tests • test schedules
Test standards	Confirmation to perform tests as per specified standard
Commissioning tests and schedule	Provide list of proposed commissioning tests and testing schedule

A.2.3.6 Auxiliary systems

Purchaser specification requirements	Manufacturer supplied information
Auxiliary power and cooling facility prepared by the purchaser side	Auxiliary power facility required and system description Method of initial energizing, restart and shutdown
Requirement for the control facilities	Description of control facilities including remote and local man-machine interfaces, detailing control, alarm, communication and monitoring facilities*
Auxiliary systems on main equipment	
Fire safety requirements	<ul style="list-style-type: none"> • Description of materials used* • Description of means of protecting against fire* • Fire containment methods*

Annex B (informative)

Modulation strategies for 2-level converters

B.1 Carrier wave PWM

Figure B.1 a) shows the control signals (the carriers and the voltage references as sine wave) for a PWM VSC. Figure B.1 b) shows the resulting voltage V_{am} at the AC terminal a, with respect to a hypothetical midpoint m of the DC capacitor. In this example, the frequency of the carrier (triangular wave signal) is nine times the fundamental frequency.

The general harmonic form of the switched waveform of Figure B.1 b) can be written as:

$$v_{am}(t) = \frac{U_d}{2} M \cos(\omega_1 t + \theta_1) + \sum_{m=1}^{\infty} \sum_{n=-\infty}^{\infty} C_{mn} \cos[m(\omega_c t + \theta_c) + n(\omega_1 t + \theta_1)]$$

where

M is the modulation index;

ω_1 is the fundamental frequency;

ω_c is the carrier frequency;

m is a multiple of the carrier frequency;

n is a multiple of the fundamental frequency;

θ_1 is an arbitrary phase offset of the fundamental waveform;

θ_c is an arbitrary phase offset of the carrier waveform.

The most effective approach to determine the harmonic coefficients C_{mn} is using double integral Fourier form as:

$$C_{mn} = \frac{1}{2\pi^2} \int_{-\pi}^{\pi} \int_{-\pi}^{\pi} F(x, y) e^{j(mx+ny)} dx dy$$

where

$F(x, y)$ is the switched waveform for one fundamental cycle;

$x = \omega_c t$;

$y = \omega_1 t$.

The general harmonic form of the switched waveform defines carrier multiple harmonics (when $m \neq 0$ and $n = 0$) and sideband harmonics around the carrier multiples (when $m \neq 0$ and $n \neq 0$). Figure B.1 shows the typical harmonic spectra of the voltage waveforms for phase-to-floating neutral and phase-to-phase, respectively, for a 2-level VSC using PWM switched waveforms with a carrier-based control method using 21 times fundamental frequency and assuming infinite DC capacitance (i.e. no DC voltage ripple). These harmonic spectra would be changed under different specific operating conditions.

For a three-phase 2-level VSC, a balanced set of three-phase line-line output voltages is obtained if the phase leg references are displaced by 120° . In this case, the triplen sideband harmonics around each carrier multiple are cancelled in the line-line output voltages. It is important to note that the harmonic cancellation is a consequence of the triplen sideband harmonics. The carrier/fundamental ratio has no influence, and it can be odd, even or not integer.

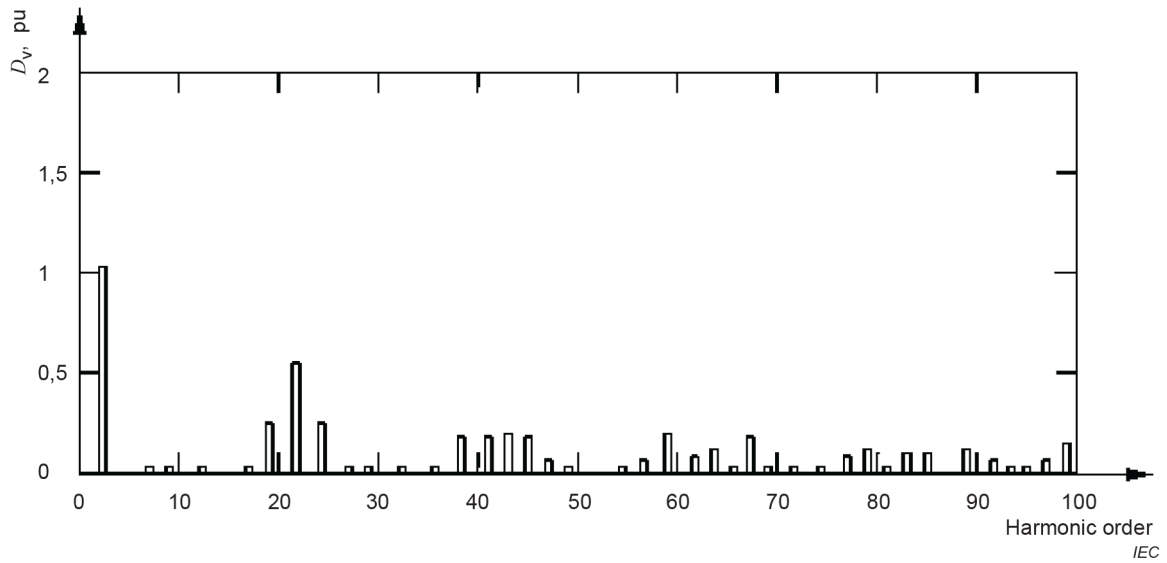

a) Phase-to-floating neutral voltage amplitude versus harmonic order

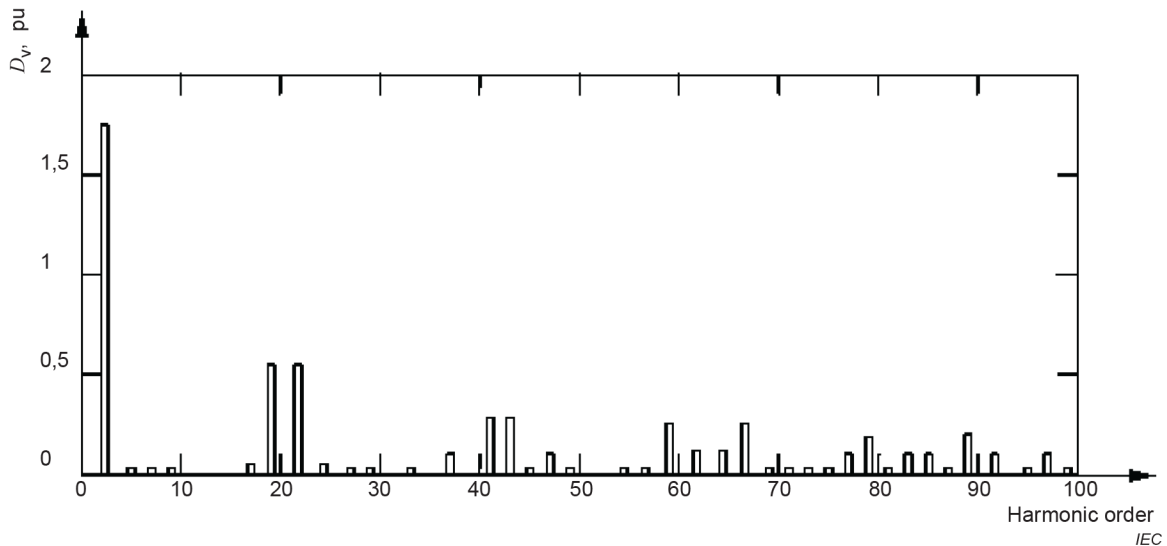

b) Phase-to-phase voltage amplitude versus harmonic order

Figure B.1 – Voltage harmonics spectra of a 2-level VSC with carrier frequency at 21st harmonic

B.2 Selective harmonic elimination modulation

Selective harmonic elimination modulation (SHEM) is known as a modulation method to eliminate the undesirable low order harmonics. SHEM approach is an effective way to eliminate the selected most significant harmonics using lower switching frequency. Figure B.2 shows the waveform switched at predetermined angles. The switched waveform has odd half-wave symmetry and even quarter-wave symmetry. The K switching angles can be used to eliminate $K - 1$ significant harmonic component and control the fundamental voltage.

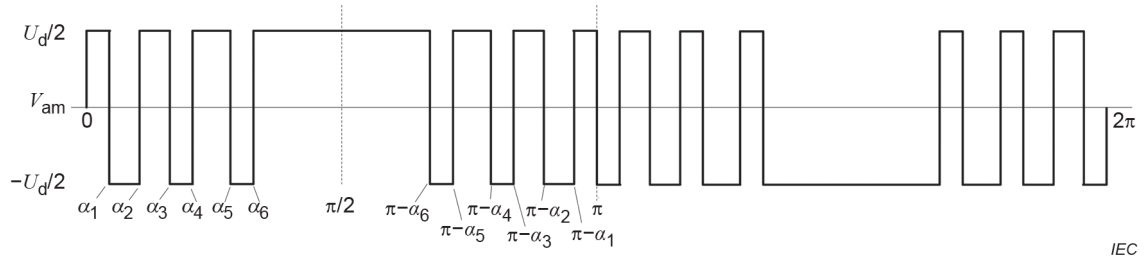

Figure B.2 – Phase output voltage for selective harmonic elimination modulation (SHEM)

The general Fourier series of the switched waveforms shown in Figure B.2 can be given as

$$v_{am}(t) = \sum_{n=1}^{\infty} (a_n \cos n\omega t + b_n \sin n\omega t)$$

For a waveform with quarter-wave symmetry, only the odd harmonics with sine component will be present. Therefore,

$$a_n = 0$$

$$b_n = \frac{4}{n\pi} \left[1 + 2 \sum_{k=1}^K (-1)^k \cos n\alpha_k \right]$$

Note that K number of simultaneous equations are required to solve the K number of switching angles. The fundamental voltage can be controlled using one equation, and $K - 1$ harmonics can be eliminated using the other $K - 1$ equations. Usually, the lowest significant harmonics are to be eliminated. For a three-phase three-wire 2-level VSC, the triplen harmonics can be ignored if the phase references are displaced by 120° .

Bibliography

- [1] CIGRE Technical Brochure No. 492, *Voltage Source Converter (VSC) HVDC for Power Transmission – Economic Aspects and Comparison with other AC and DC Technologies*
 - [2] CIGRE Technical Brochure No. 269, *VSC Transmission*
 - [3] CIGRE Technical Brochure No. 447, *Component Testing of VSC System for HVDC Applications*
 - [4] IEC TR 62001-1, *High-voltage direct current (HVDC) systems – Guidance to the specification and design evaluation of AC filters – Part 1: Overview*
 - [5] CIGRE Technical Brochure No. 811, *DC side harmonics and filtering in HVDC transmission systems*, 2020
 - [6] CIGRE Technical Brochure No. 370, *Integration of large scale wind generation using HVDC & power electronics*
 - [7] IEC 61803, *Determination of power losses in high-voltage direct current (HVDC) converter stations with line-commutated converters*
 - [8] IEC 62751 (all parts), *Power losses in voltage sourced converter (VSC) valves for high-voltage direct current (HVDC) systems*
 - [9] IEC 62751-1, *Power losses in voltage sourced converter (VSC) valves for high-voltage direct current (HVDC) systems – Part 1: General requirements*
 - [10] IEC 62751-2, *Power losses in voltage sourced converter (VSC) valves for high-voltage direct current (HVDC) systems – Part 2: Modular multilevel converters*
 - [11] IEC TR 62001-5, *High-voltage direct current (HVDC) systems – Guidance to the specification and design evaluation of AC filters – Part 5: AC side harmonics and appropriate harmonic limits for HVDC systems with voltage sourced converters (VSC)*
 - [12] IEC TR 62001 (all parts), *High-voltage direct current (HVDC) systems – Guidance to the specification and design evaluation of AC filters*
 - [13] IEC TS 61973, *High voltage direct current (HVDC) substation audible noise*
 - [14] IEC 61000 (all parts), *Electromagnetic compatibility (EMC)*
 - [15] CIGRE Technical Brochure No. 697, *Commissioning of VSC HVDC schemes*
 - [16] IEC 62501, *Voltage sourced converter (VSC) valves for high-voltage direct current (HVDC) power transmission – Electrical testing*
-

INTERNATIONAL
ELECTROTECHNICAL
COMMISSION

3, rue de Varembé
PO Box 131
CH-1211 Geneva 20
Switzerland

Tel: + 41 22 919 02 11
info@iec.ch
www.iec.ch