जलमिति — ध्वनिक डॉप्लर प्रोफाइलर —
खुले चैनलों में चलती नाव से प्रवाह माप की
विधि और अनुप्रयोग
(पहला पुनरीक्षण)

**Hydrometry — Acoustic Doppler
Profiler — Method and Application
for Measurement of Flow in Open
Channels from Moving a Boat**
(*First Revision*)

ICS 17.120.20

© BIS 2024
© ISO 2021



भारतीय मानक ब्यूरो
BUREAU OF INDIAN STANDARDS
मानक भवन, 9 बहादुर शाह ज़फर मार्ग, नई दिल्ली - 110002
MANAK BHAVAN, 9 BAHADUR SHAH ZAFAR MARG
NEW DELHI - 110002
www.bis.gov.in www.standardsbis.in

NATIONAL FOREWORD

This Indian Standard (First Revision) which is  identical to ISO 24578 : 2021 'Hydrometry — Acoustic doppler profiler — Method and application for measurement of flow in open channels from moving a boat' issued by the International Organization for Standardization (ISO) was adopted by the Bureau of Indian Standards on the recommendation of the Hydrometry Sectional Committee and approval of the Water Resources Division Council.

This standard was first published in 2014 based on ISO/TR 24578 : 2012. This revision has been brought out to align it with the latest version of ISO 24578 : 2021.

The text of ISO standard has been approved as suitable for publication as an Indian Standard without deviations. Certain conventions and terminologies are, however, not identical to those used in Indian Standards. Attention is particularly drawn to the following:

- a) Wherever the words 'International Standard' appear referring to this standard, they should be read as 'Indian Standard'; and
- b) Comma (,) has been used as a decimal marker while in Indian Standards, the current practice is to use a point (.) as the decimal marker.

In this adopted standard, reference certain to International Standards appears for which Indian Standard also exists. The corresponding Indian Standards, which are to be substituted in their place, are listed below along with their degree of equivalence for the editions indicated:

<i>International Standard</i>	<i>Corresponding Indian Standard</i>	<i>Degree of Equivalence</i>
ISO 772 : 2022 Hydrometry — Vocabulary and symbols	IS 1191 : 2016 Hydrometric determinations — Vocabulary and symbols (<i>third revision</i>)	Technically Equivalent

For the purpose of deciding whether a particular requirement of this standard is complied with the final value, observed or calculated expressing the result of a test or analysis shall be rounded off in accordance with IS 2 : 2022 'Rules for rounding off numerical values (*second revision*)'. The number of significant places retained in the rounded off value should be the same as that of the specified value in this standard.

Contents

Page

Introduction	v
1 Scope	1
2 Normative references	1
3 Terms and definitions	1
4 Principles of the boat mounted ADCP method	3
4.1 General.....	3
4.2 Doppler principle applied to moving objects.....	4
4.3 Acoustic Doppler current profiler techniques.....	5
4.3.1 General.....	5
4.3.2 Pulse incoherent.....	5
4.3.3 Pulse-to-pulse coherent.....	6
4.3.4 Broadband (Spread spectrum).....	6
4.4 Measurement of velocity profile.....	6
4.4.1 General.....	6
4.4.2 Measurement of relative velocity.....	6
4.4.3 Measurement of boat velocity.....	6
4.4.4 Near boundary data collection.....	8
4.5 Speed of sound in water.....	10
5 Flow determination	11
5.1 General method.....	11
5.2 Measurement procedure.....	13
5.3 Method dealing with moving-bed condition without GNSS system.....	15
5.3.1 General.....	15
5.3.2 Stationary moving-bed method.....	15
5.3.3 Azimuth method.....	16
5.3.4 Subsection correction method.....	16
5.3.5 Loop method.....	17
5.3.6 Mid-section method.....	19
6 Site selection	19
6.1 General.....	19
6.2 Site-selection criteria.....	20
7 ADCP Deployment procedure	21
7.1 Deployment techniques.....	21
7.1.1 General.....	21
7.1.2 Manned boat mounted.....	21
7.1.3 Tethered boat.....	21
7.1.4 Deployment on a remote-control craft.....	22
7.1.5 Data retrieval modes.....	22
7.2 Operation of boat.....	22
7.2.1 Boat path.....	22
7.2.2 Boat speed.....	23
7.3 Field procedures.....	23
7.3.1 Pre-field procedures.....	23
7.3.2 Field setup.....	23
7.3.3 Reviewing ADCP data during measurement.....	26
7.3.4 Post measurement requirements.....	26
7.4 Ancillary equipment.....	27
7.5 Other consideration.....	27
7.5.1 Edge distances.....	27
7.5.2 Depth measurements at sites with high sediment concentrations.....	27
7.5.3 GNSS compass.....	28

7.6	Maintenance and ADCP checks	28
7.6.1	General	28
7.6.2	Built-in diagnostic check	28
7.6.3	Periodic major service in the manufacturer	28
7.6.4	Periodic ADCP performance check	28
7.6.5	Physical maintenance	28
7.6.6	Beam-alignment test	28
7.7	Training	29
8	Uncertainty	29
8.1	General	29
8.2	Definition of uncertainty	29
8.3	Uncertainties in ADCP measurements — General considerations	30
8.4	Sources of uncertainty	30
8.5	Minimizing uncertainties	31
Annex A (informative) Velocity distribution theory and the extrapolation of velocity profiles		32
Annex B (informative) Determination of edge discharges		34
Annex C (informative) Example of an equipment check list		36
Annex D (informative) Example of ADCP gauging field sheets		38
Annex E (informative) Beam alignment test		42
Annex F (informative) Uncertainty evaluation methods		44
Bibliography		45

Introduction

The term acoustic Doppler current profilers (ADCP) has been adopted as a generic term for a technology that is manufactured by various companies worldwide. They are also called acoustic Doppler velocity profilers (ADVPs) or acoustic Doppler profilers (ADPs).

To use this document effectively, it is essential that users are familiar with the terminology and functions of their own ADCP equipment. Users should also be familiar with additional requirements.

HYDROMETRY — ACOUSTIC DOPPLER PROFILER — METHOD AND APPLICATION FOR MEASUREMENT OF FLOW IN OPEN CHANNELS FROM MOVING A BOAT

(First Revision)

1 Scope

This document gives guidelines for the use of boat-mounted acoustic Doppler current profilers (ADCPs) for determining flow in open channels. It describes a number of methods of deploying ADCPs to determine flow. Although, in some cases, these measurements are intended to determine the stage-discharge relationship of a gauging station, this document deals only with single determination of discharge.

ADCPs can be used to measure a variety of parameters, such as current or stream flow, water velocity fields, and channel bathymetry. As a potential application, an idea of bedload discharge can be obtained applying the bottom track velocity, while suspended sediment flow can be obtained applying the acoustic backscatter and the sonar equation. This document is generic in form and contains no operational details specific to particular ADCP makes and models.

2 Normative references

The following documents are referred to in the text in such a way that some or all of their content constitutes requirements of this document. For dated references, only the edition cited applies. For undated references, the latest edition of the referenced document (including any amendments) applies.

ISO 772, *Hydrometry — Vocabulary and symbols*

3 Terms and definitions

For the purposes of this document, the terms and definitions given in ISO 772 and the following apply.

ISO and IEC maintain terminological databases for use in standardization at the following addresses:

- ISO Online browsing platform: available at <https://www.iso.org/obp>
- IEC Electropedia: available at <http://www.electropedia.org/>

3.1

transducer depth

ADCP depth

draft

depth of the ADCP transducers below the water surface during *deployment* (3.6)

Note 1 to entry: The ADCP depth should be measured manually.

3.2

bin

depth cell

truncated cone-shaped volume of water at a known distance and orientation from the transducers

Note 1 to entry: The ADCP determines an estimated velocity for each cell using a centre-weighted averaging scheme, which takes account of the water not only in the bin itself but also in the two adjacent bins.

3.3 blanking distance blank

distance travelled by the signal when the vibration of the transducer during transmission prevents the transducer from receiving echoes or return signals

Note 1 to entry: This is the distance immediately below the ADCP transducers in which no measurement is taken.

Note 2 to entry: The distance should be the minimum possible. However, care should be taken not to make the distance too short in order to avoid signal contamination by ringing or bias due to flow disturbance.

3.4 bottom tracking

acoustic method used to measure boat speed and direction by computing the Doppler shift of sound reflected from the stream bed relative to the ADCP

Note 1 to entry: With no moving bed, the discharge can be computed with bottom velocity and water velocity data because this is done in ADCP coordinates not earth coordinates. With moving bed, the use of a Global Navigation Satellite System (GNSS) or loop-corrected data using a calibrated compass is required.

3.5 real-time mode

mode in which the ADCP relays information to the operating computer as it gathers it

Note 1 to entry: The ADCP and computer are connected (physically or wireless) throughout the *deployment* (3.6) in this mode.

3.6 deployment

ADCP initialized and activated to collect data while the ADCP is propelled across the section to record data

Note 1 to entry: A deployment typically includes several pairs of *transects* (3.11) or traverses across a river or estuary.

3.7 deployment method

technique used to propel the ADCP across a watercourse

Note 1 to entry: One of three different deployment methods is used: a manned boat; a tethered boat; or a remote-controlled boat.

3.8 ensemble profile

single measurement of the water column

Note 1 to entry: A column of *bins* (3.2) is equivalent to a vertical in conventional current meter gauging.

3.9 ping

entirety of the sound generated by an ADCP transducer for a single measurement cycle

Note 1 to entry: Sound pulses transmitted by the ADCP for a single measurement.

3.10 self-contained mode autonomous mode

data retrieval mode in which the ADCP stores the information it gathers within its own memory and then downloaded to a computer after *deployment* (3.6)

Note 1 to entry: This method is generally not used by majority of ADCP practitioners nor recommended by the majority of hydrometric practitioners.

3.11 transect pass

one sweep across the watercourse during an ADCP deployment (3.6)

Note 1 to entry: In the *self-contained mode* (3.10), a deployment can consist of any number of transects.

4 Principles of the boat mounted ADCP method

4.1 General

The ADCP is a device for measuring current velocity and direction, throughout the water column, in an efficient and non-intrusive manner. It can produce an instantaneous velocity profile through the water column while disturbing only the top few decimetres. ADCPs nominally work using the Doppler principle (see 4.2). An ADCP is usually a cylinder with a transducer head on the end (see Figure 1). The transducer head is typically a ring of three or more acoustic transducers with their faces angled to the horizontal and at specified angles to each other. Some ADCPs use phased array transducers, which contain many elements that can form multiple beams at various angles, depending on transducer design. A single phased array transducer can form the three or more beams needed for an ADCP.

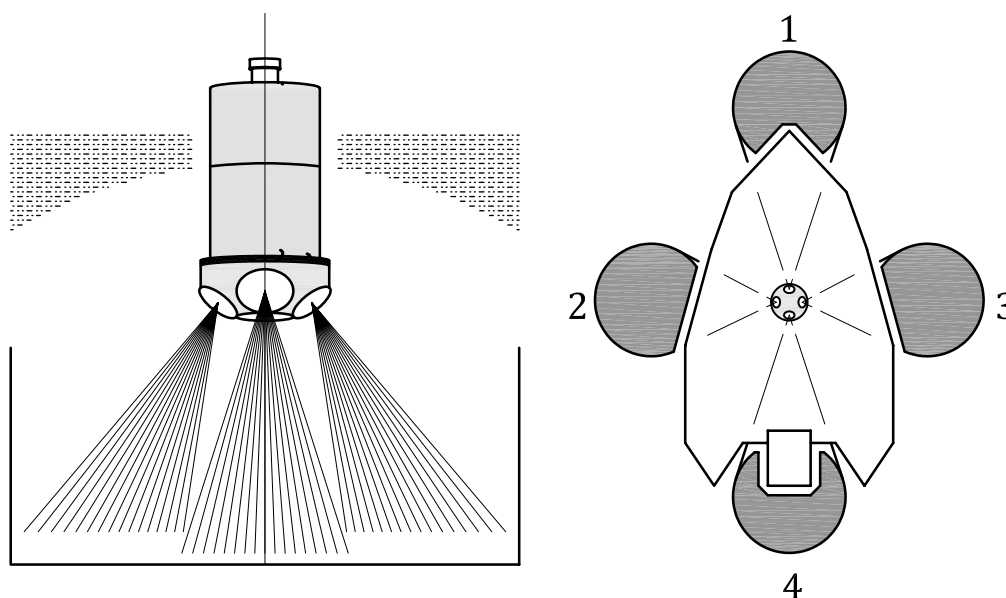

Key

- 1 forward
- 2 port or left
- 3 starboard or right
- 4 aft or backward

NOTE ADCP can work in any position or orientation; this figure is an indicative illustration.

Figure 1 — Example sketch illustrating typical ADCP with four transducers

The ADCP, which was originally developed for oceanographic work, has since been developed for use in estuaries and rivers. An ADCP can be mounted on a boat, flotation collar, or raft, and propelled across a river (see Figure 2). The ADCP collects velocity data, direction of flow, depth data, and boat speed, direction, and position. With such information, discharge values are independent of the path; in other words, the route taken does not need to be straight or perpendicular to the bank.

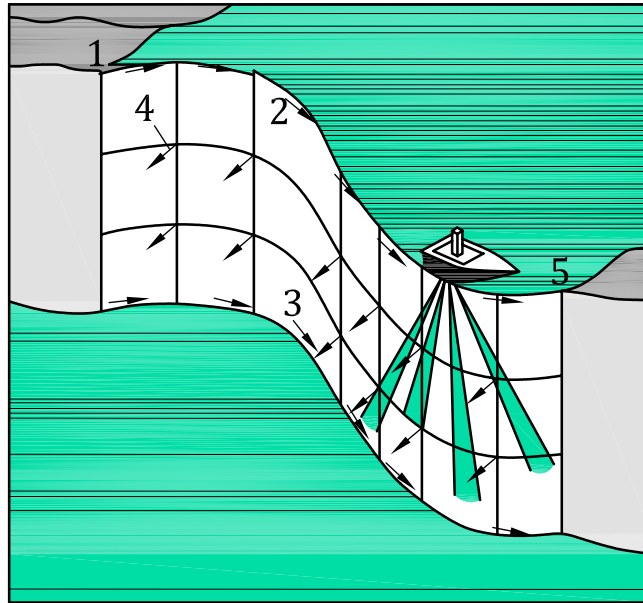

Key

- 1 start
- 2 path of boat
- 3 path of boat on river bottom
- 4 flow velocity vectors
- 5 finish

Figure 2 — Sketch illustrating moving — Boat ADCP deployment principles

4.2 Doppler principle applied to moving objects

The ADCP uses ultrasound to measure water velocity using a principle of physics discovered by Christian Doppler. The reflection of sound waves from a moving particle causes a change in frequency to the reflected sound wave. The difference in frequency between the transmitted and reflected sound wave is known as the Doppler shift (see [Figure 3](#)).

It should be noted that only the component of velocity parallel to the direction of the sound wave produces a Doppler shift. Thus, particles moving at right angles to the direction of the sound waves (i.e. with no velocity components in the direction of the sound wave) will not produce a Doppler shift.

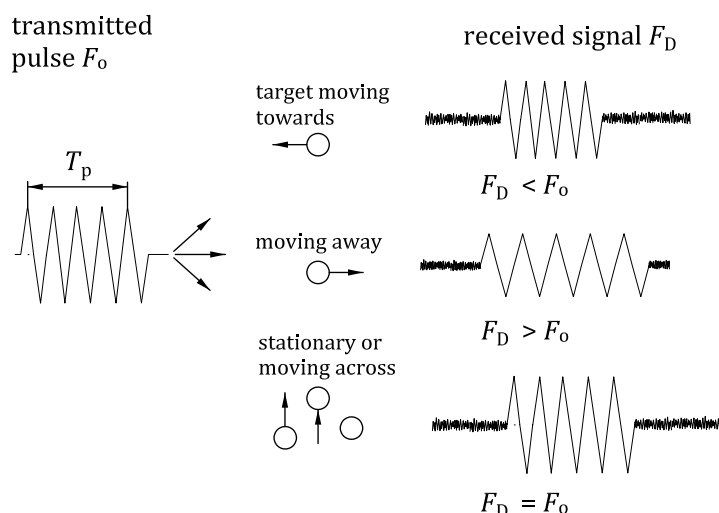

Figure 3 — Reflection of sound — Waves by a moving particle results in an apparent change in the frequency of those sound waves

Doppler's principle relates the change in frequency to the relative velocities of the source (reflector) and the observer. In the case of most ADCPs, the transmitted sound is reflected off particulates or air bubbles in the water column and reflected back to the transducer. It is assumed that the particulates move at the same velocity as the water and, from this, the frequency shift can be translated to a velocity magnitude and direction. The particulates in the river are generally suspended sediments (SS). A very low SS concentration results in no data because there is no return signal, while a very high SS disrupts the signal, and also results in no data. Therefore, ADCP frequency shall be chosen according to these criteria. The more suspended sediment that are in water, the lower the ADCP operating frequency should be. In addition to that, it should also be noted that excessive air bubbles can cause distortion in, or loss of, the returned signal. Furthermore, air bubbles naturally rise and therefore are likely not to be travelling in a representative magnitude and direction.

4.3 Acoustic Doppler current profiler techniques

4.3.1 General

There are three general types of ping configuration and processing algorithms used in ADCPs:

- pulse incoherent (including narrowband) — Doppler shift long pulse,
- pulse-to-pulse coherent — Doppler shift short pulse, and
- broad band (spread spectrum) — phase shift on two short pulses.

Reference should be made to the ADCP manual to determine the type being used.

4.3.2 Pulse incoherent

An incoherent ADCP transmits a single, relatively long, pulse of sound and measures the Doppler shift, which is used to calculate the velocity of the particles along the path of the acoustic beam. The velocity measurements made using incoherent processing are very robust over a large velocity range, although they have a relatively high short-term (single ping) uncertainty. To reduce the uncertainty, multiple pulses are transmitted over a short time period; these are then averaged before reporting a velocity. "Narrowband" is used in the industry to describe a pulse-to-pulse incoherent ADCP. In a narrowband ADCP, only one pulse is transmitted into the water per beam per measurement (ping), and the resolution of the Doppler shift shall take place during the duration of the received pulse. The narrowband acoustic pulse is a simple monochromatic wave and can be processed quickly.

4.3.3 Pulse-to-pulse coherent

Coherent ADCP systems are the most accurate of the three, although they have significant range limitations. Coherent systems transmit one, relatively short pulse, record the return signal, and then transmit a second short pulse when the return from the first pulse is no longer detectable. The ADCP measures the phase difference between the two returns and uses this to calculate the Doppler shift. Velocity measurements made using coherent processing are very precise (low short-term uncertainties), but they have significant limitations. Coherent processing will work only in limited depth ranges and with a significantly limited maximum velocity. If these limitations are exceeded, velocity data from a coherent Doppler system are effectively meaningless.

4.3.4 Broadband (Spread spectrum)

Like coherent systems, broadband ADCP systems transmit two pulses and look at the phase change of the return from successive pulses. However, with broadband systems, both acoustic pulses are within the profiling range at the same time. The broadband acoustic pulse is complex; it has a code superimposed on the waveform. The code is imposed on the wave form by reversing the phase and creating a pseudo-random code within the wave form. This pseudo-random code allows a number of independent samples to be collected from a single ping. Due to the complexity of the pulse, the processing is slower than in a narrowband system; however, multiple independent samples are obtained from each ping.

The short-term uncertainty of velocity measurements using broadband processing is between that of incoherent and coherent systems. Broadband systems are capable of measuring over a wider velocity range than coherent systems; although, if this range is exceeded, the velocity data will be rendered meaningless. The accuracy and maximum velocity range of a broadband system is a function of the precise processing configuration used.

4.4 Measurement of velocity profile

4.4.1 General

ADCPs measure velocity profiles relative to the ADCP. In order to obtain an absolute velocity profile, a combination of relative velocity and boat velocity are necessary.

4.4.2 Measurement of relative velocity

The velocity is measured as a centre-weighted average that spans the cells above and below as described in [4.3](#) and the result is reported at the depth of the cell centre. With these results and using trigonometric relations, a 3-dimensional water velocity is computed and assigned to a given depth cell in the water column. Although this is analogous to a velocity profile obtained from a point velocity meter, the entire measurable region of the water column is sampled by the ADCP. Acoustic pulse requires to be stabilized, in order to obtain data. The blanking distance exists in order for acoustic pulse to stabilize (see [Figure 4](#)).

4.4.3 Measurement of boat velocity

4.4.3.1 Bottom tracking

The ADCP can use the Doppler principle to track their movements across a channel using a technique called “bottom tracking”. Bottom-tracking measurements are similar to water-velocity measurements, but separate pulses are used. Bottom-tracking pings are longer than water pings. These pings are also used to measure the depth of water. The sound pulses are reflected from the stream bed and used to calculate the velocity of the ADCP relative to the bed. ADCPs may also have an on-board compass and can combine this data with bottom-tracking data to determine boat direction and speed assuming the stream bed is stable.

In order to conduct the water and bottom tracking measurements, first, the ADCP sends a pulse to measure the boat velocity which is just the opposite of bottom velocity relative to the ADCP. Second,

the ADCP sends a pulse to measure water velocity relative to the ADCP. Third, the ADCP combines these two velocity vectors (water and boat) to compute the absolute water velocity. To do this with accuracy, two conditions shall be met.

- a) The stream bed should not move, otherwise the water velocity can be under estimated. In this case, Global Navigation Satellite System (GNSS) should be implemented or special treatments shall be taken care as described in [5.3](#).
- b) The boat should not move or rotate between the pulse for bottom velocity and the pulse for water velocity. Otherwise, there is an angle error between the velocity water vector and the boat velocity vector.

To ensure that these conditions are met:

- 1) test for a moving stream bed using a stationary method, loop test, or GNSS;
- 2) deployment of boat has to be smooth and even, and slow relative to the water velocity.

4.4.3.2 Global Navigation Satellite System (GNSS)

A GNSS may be integrated with an ADCP to provide position and boat velocity data. This is used as an alternative to bottom tracking when the bed is unstable due to high bedload discharge or when bottom tracking is unable to accurately determine bed level due, for example, to vegetation growth or heavy suspended sediments. It is important to implement the most accurate GNSS system available to users. The accuracy of the GNSS may be affected by trees or buildings on the river bank on narrow rivers. When GNSS can only sight four or less satellites at one time, the accuracy of the ADCP is reduced considerably. The GNSS system should warn the user when this occurs.

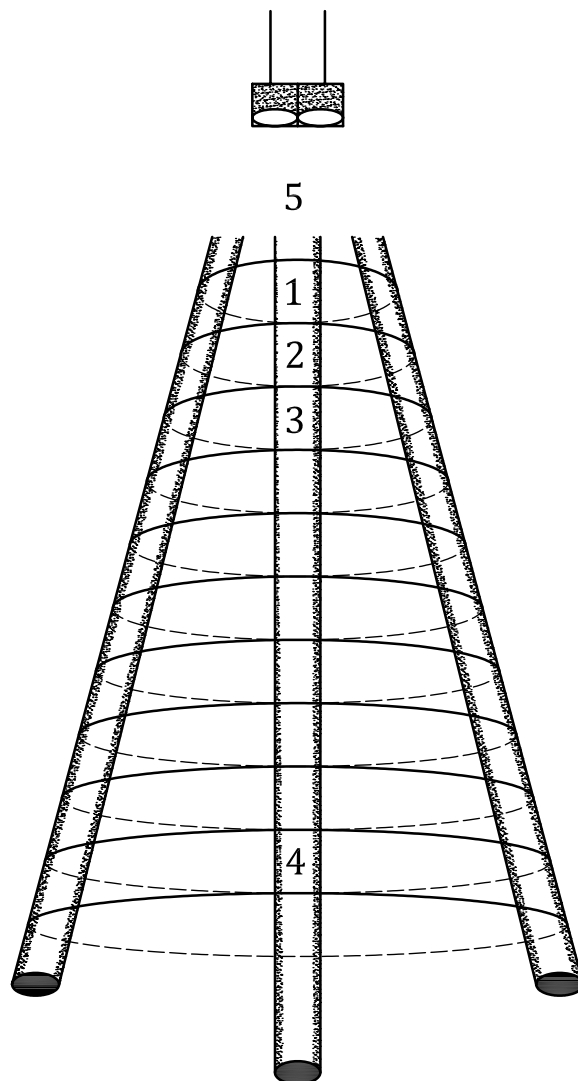

- Key**
- 1 cell/bin 1
 - 2 cell/bin 2
 - 3 cell/bin 3
 - 4 cell/bin n
 - 5 blanking distance

Figure 4 — ADCP depth cells or bins

4.4.4 Near boundary data collection

The angle of the ADCP transducers varies depending on the manufacturer and type. It typically ranges between 20° and 30° from the vertical. The ADCP cannot measure all the way to the stream bed. When acoustic transducers produce sound, most of the energy is transmitted in the main beam. However, there are also side lobes that contain less energy that propagate from the transducer as well. These side lobes do not pose a problem in most of the water column because they emit low energy. However, when the side lobe strikes the stream bed, the stream bed is a good reflector of this acoustic energy, and much of the energy is reflected back to the transducer. Due to the slant of the beams, the acoustic energy in the main beam reflects off scatterers in the water column near the bed at the same time that a vertical side lobe reflects from the stream bed. The energy in the main beam reflected from these scatterers in the water column is relatively low compared to the energy in the side lobe returned from the stream bed, which may contaminate the velocity measurement near the bed. Therefore, there is an

area near the bottom that cannot be measured due to side-lobe interference. This distance is computed as shown in [Formula \(1\)](#):

$$[1 - \cos(\theta)] \times 100 \quad (1)$$

where θ is beam angle.

Thus, for a 20° system, it is 6 % of the range from the transducer. As the profile approaches the boundary, interference occurs due to reflection of side-lobe energy taking a direct (shorter) path to the boundary (see [Figure 5](#)).

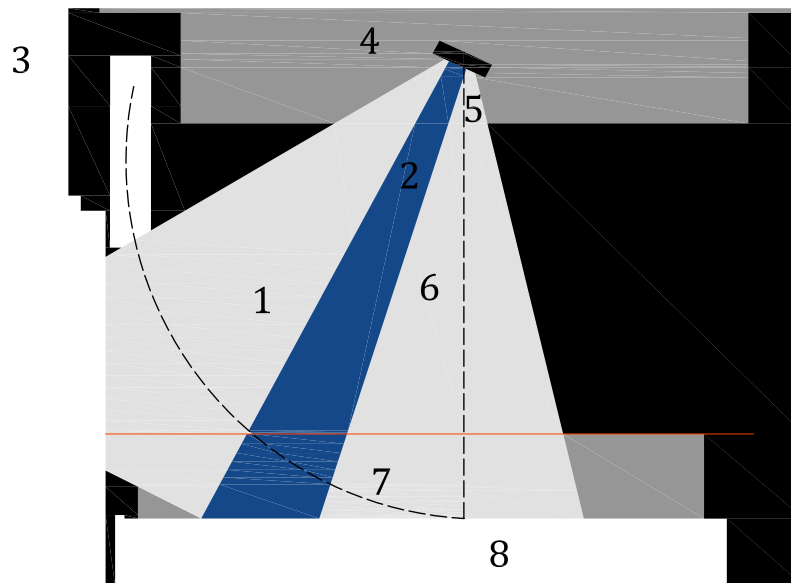

Key

- 1 side lobe
- 2 main beam
- 3 maximum slant range
- 4 depth of sensor and draft of boat
- 5 blanking distance
- 6 depth of measured discharge
- 7 side-lobe interference
- 8 stream bed

Figure 5 — Depth zones within the water column

To ensure that there is no bias in the velocity estimate, the ADCP and its software should ignore that portion of the water column affected by side-lobe contamination near the bed. This is undertaken automatically by the ADCPs in current use. The user manual should provide information on this.

To measure the velocity at a precise depth, it is necessary to have a reliable measurement on three beams at this depth. Any data beyond the range of the shortest beam is suspect because it may be contaminated by reflections from the boundary of the shortest beam. Only data above the shortest beam should be used.

As illustrated in [Figure 6](#), the ADCP is unable to make velocity measurements in three areas:

- near the surface (due to the depth at which the ADCP is located in the water and, added to this, the blanking distance);

- near the bed (due to side lobe interference, channel undulations and acoustic reflections caused at the bed);
- near the channel edges (due to a lack of sufficient water depth or to acoustic interference from signals returned from the bank).

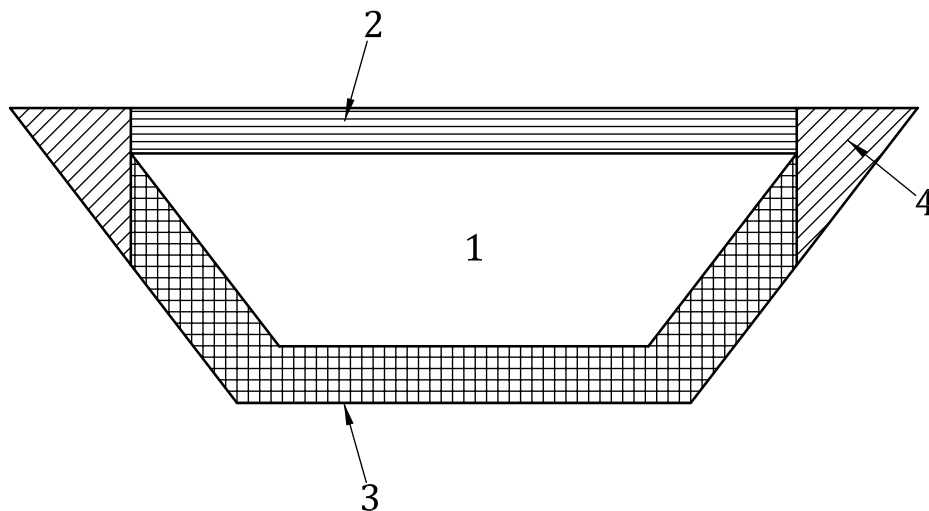

Key

- 1 measured area
- 2 near the surface as unmeasured area
- 3 near the bed as unmeasured area
- 4 edge as unmeasured area

NOTE Velocity is only measured in the central area, elsewhere it is estimated by extrapolation.

Figure 6 — Measured and un-measured area

4.5 Speed of sound in water

The calculated velocity is directly related to the speed of sound in the water. The speed of sound varies significantly with changes in pressure, water temperature, and salinity, but is most sensitive to changes in water temperature. Most manufacturers of ADCP systems measure water temperature near the transducer faces and apply correction factors to allow for temperature related differences in the speed of sound. Temperature changes that occur with depth do not affect the horizontal velocity but will affect the measured depth. If ADCPs do not have temperature compensation facilities, user should avoid to use it, or the user shall measure the water temperature with a thermometer or another sensor at the time of the ADCP data collection.

NOTE 1 In most well-mixed rivers, the temperature is the same or nearly the same from top to bottom.

NOTE 2 Most post-processing software can reprocess the data with a measured water temperature when the internal sensor malfunctions.

If the ADCP is to be used in waters of varying salinity, the software used to collect data should have the facility to correct for salinity.

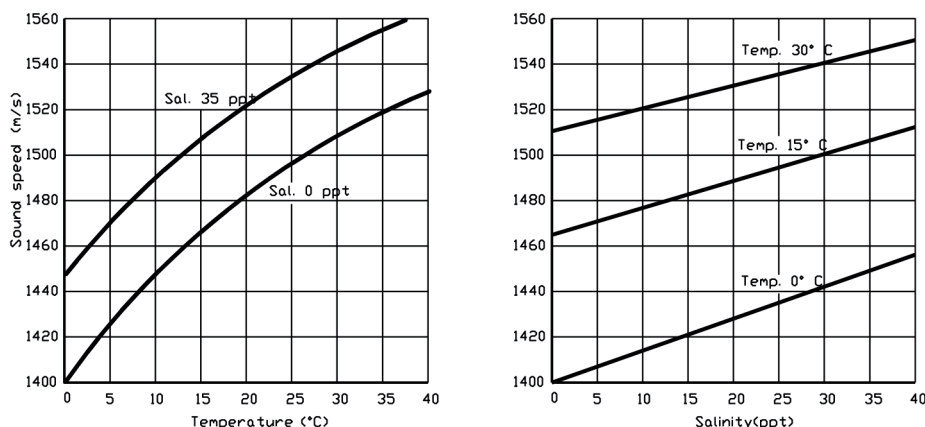

a) Sound speed as a function of temperature at different salinity levels

b) Salinity at different temperature level

Figure 7 — Effect of temperature and salinity on the speed of sound

Figure 7 indicates the effect of temperature and salinity on the speed of sound. As a general rule:

- a temperature change of 5 °C results in a sound speed change of 1 % to 2 %;
- a salinity change of 12 ppt (parts per thousand) results in a change in sound speed of 1 %; freshwater is 0 ppt and seawater is in the region of 30 ppt to 35 ppt);
- the full range of typical temperature and salinity levels (–2 °C to 40 °C and 0 to 40 ppt) gives a sound speed range of 1 400 m/s to 1 570 m/s (total change of 11 %).

5 Flow determination

5.1 General method

In order to determine the discharge, it is necessary to obtain velocity profiles. The velocity profiles can be determined with flow data obtained by ADCP, and a boat velocity obtained by either bottom tracking or GNSS (see 4.4.3). Care should be taken when the boat velocity cannot be appropriately obtained (see 5.3).

An ADCP determines the velocity in each depth cell (see Figure 8). Knowing the depth cell size and distance between successive ensembles, the discharge for that cell can be computed. The velocities in the unmeasured areas of the cross section are extrapolated from those of the depth cells. For example, these are at the top near the surface, at the bottom near the stream bed, and at the right and left bank, where the ADCP cannot measure. The discharge for top and bottom unmeasured area is estimated using an appropriate extrapolation technique (see Annex A) and added to that through the measured area to produce a total discharge for each ensemble. The discharge for the portion of the cross section where measurements are made is the sum of the ensemble discharges. The discharge in the unmeasured portions between the start bank and the first ensemble and between the last ensemble and the finish bank are determined using an appropriate algorithm (see Annex B). The discharge in the unsampled portion is then added to the total ensemble discharge to estimate the total discharge in the cross section.

This can be represented mathematically, as shown in Formulae (2) and (3):

$$Q_t = \sum_{j=1}^M \sum_{i=1}^{N_j} q_{i,j} + q_e \quad (2)$$

where

- Q_t is the total discharge in the cross section;
- $q_{i,j}$ are the incremental discharges through each measured depth cell in the cross section;
- q_e are the extrapolated discharges through the unmeasured areas in the cross section;
- i is the cell index in the vertical;
- M is the number of ensemble in the transect;
- j is the ensemble index in the horizontal;
- N_j is the number of cells in the j th ensemble.

$$q_e = q_{lb} + q_{rb} + q_{top} + q_b \tag{3}$$

where

- q_{lb} is the discharge at the left bank edge by velocity extrapolation;
- q_{rb} is the discharge at the right bank edge by velocity extrapolation;
- q_{top} is the discharge in top portion determined by the ADCP by velocity profile extrapolation;
- q_b is the discharge in bottom portion determined by the ADCP by velocity profile extrapolation.

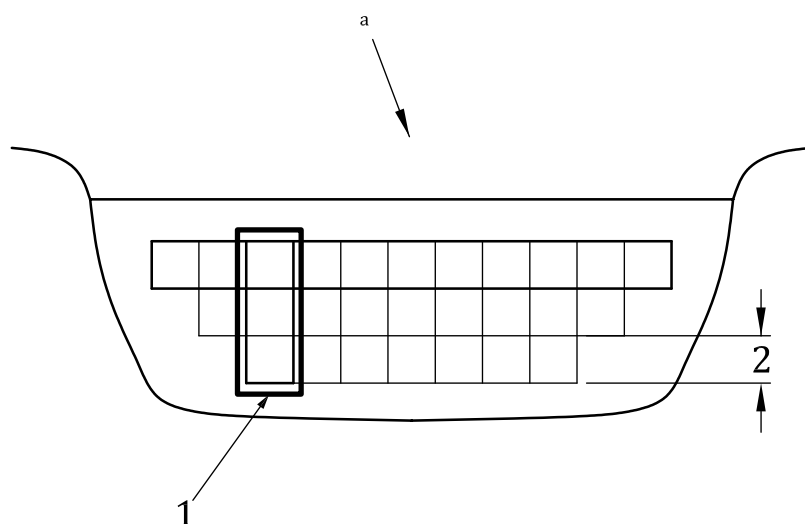

- Key**
- 1 ensemble
 - 2 cell size
 - a Flow.

Figure 8 — Measured area of the channel cross section, divided into individual ensembles and bins

To produce a discharge estimate, the ADCP shall cross a river with its transducers submerged to a known constant depth. This is best achieved by mounting the ADCP on a boat or a flotation platform. Different manufacturers supply different platforms, or one can be constructed locally. It is important to ensure that the flotation platform is suitable for the expected water velocity range for which measurement is about to be undertaken. Platforms may capsize if the water velocity is too high.

The edge discharge is estimated with the averaging ensemble from the first ensembles or the end ensembles. Indeed, these ensembles shall be representative of the velocity near the bank. The ADCP needs to be stationary as long as necessary to make a good measurement: in practice 5 or 10 ensembles at the start or end point.

There can be other parts of a transect which shall be extrapolated, such as a bad cell. For example, a bad cell is a bin which the signal cannot be analysed due to bad signal correlation or when the error velocity is too high due to inhomogeneous flow. The error velocity is the difference in velocity between the vertical velocity obtained by two pairs of beams in the perpendicular plane. If bad cells exist for the entire vertical, then this is a bad ensemble. A bad ensemble will also occur if the ADCP cannot measure the boat velocity.

Different manufactures have different approaches to estimating data for bad cells or ensembles. It is necessary to relocate the boat or flotation platform and perform a new measurement to reduce uncertainty.

For all of these reasons, it is necessary that manufacturer provide enough details to know how the ADCP software works.

5.2 Measurement procedure

The procedures to adopt when undertaking a discharge measurement should include, but are not necessarily limited to, the following.

- a) Under steady flow conditions, make an even number of transects (at least two reciprocal pairs) having a total exposure time of 720 s or greater, regardless of the size of rivers. The mean of transect discharges is taken as the measured discharge, denoted by Q_{mean} . This measured discharge Q_{mean} is accepted only if its associated relative expanded uncertainty, denoted by REU, is equal to or smaller than the maximum permissible relative uncertainty (MPRU = 4,09 %). This uncertainty-based quality control criterion is written as shown in [Formula \(4\)](#):

$$\text{REU} = \frac{U_{95}}{Q_m} \leq \text{MPRU} = 4,09\% \quad (4)$$

where U_{95} is the expanded uncertainty with a coverage factor of 2. It is estimated with the transect discharges; Q_i , (a sample). See [Formula \(5\)](#):

$$U_{95} = 1,96 \frac{s}{c_4 \sqrt{n}} \quad n = 2, 4, 6, \text{ or... even number} \quad (5)$$

where

$$s = \sqrt{\frac{1}{n-1} \sum_{i=1}^n (Q_i - Q_m)^2};$$

c_4 is the bias-correction factor for s ;

$$c_4 = \sqrt{\frac{2}{n-1}} \frac{\Gamma\left(\frac{n}{2}\right)}{\Gamma\left(\frac{n-1}{2}\right)};$$

$\Gamma(\cdot)$ stands for Gamma function;

n is the number of transects;

$c_4 = 0,797\ 9, 0,921\ 3, 0,951\ 5, 0,965\ 0, \text{ and } 0,972\ 7$ at $n = 2, 4, 6, 8, 10$, respectively.

Note that this criterion is for controlling the random sampling errors only. The control for potential bias errors needs to be addressed separately (Reference [30]). If the REU of Q_m from the current measurement is equal to or smaller than 4,09 %, accept Q_m and stop the measurement. Otherwise, make 2 additional transects and recalculate Q_m and REU with the updated measurement that consists of all transects that have been made. If the REU of the updated Q_m is equal to or smaller than 4,09 %, accept this updated Q_m and stop the measurement. Otherwise, make 2 additional transects and recalculate Q_m and REU. Continue this procedure until the REU of the most updated Q_m is equal to or smaller than 4,09 %. All transects are assumed to be valid. If a transect is identified as invalid (e.g. a transect is interrupted by a passing vessel), a replacement transect is required.

b) In summary, this combined quality control requires:

- 1) minimum of 2 transects (in reciprocal pairs),
- 2) minimum of 720 s duration, and
- 3) maximum 4,09 % permissible uncertainty.

The benefit of this procedure is that it merges the advantages of both the duration control and the uncertainty control and overcomes either's short comings. The 720 s minimum duration is established on an empirical basis (see Reference [58]). Even if the exposure time of a measurement is greater than 720 s, it is possible for a transect discharge to be more than 5 % from the mean discharge of 2, 4, 6, ...n transects (see Reference [66]). On the other hand, REU is estimated with a sample (multiple transect discharges) and is a random variable. Consider the case where only two transects are made. The REU of the measurement may be smaller than 4,09 % if these two transect discharges happened to be very close, even if the exposure time of the measurement is less than 720 s. Therefore, the procedure guarantees a measurement has enough exposure time (minimum 720 s) and desired precision (MPRU = 4,09 %).

c) As already stated, whenever possible, the ADCP should be operated in the real-time (not self-contained) mode. This allows the operator to continually monitor the data and if a critical data-quality problem occurs, allows the operator to terminate the transect. A critical data quality problem may include:

- 1) use of an inappropriate operating mode;
- 2) configuration errors such as an insufficient number of depth cells to profile the channel bed;
- 3) appreciable area with missing data;
- 4) unusual boat or water velocities;
- 5) excessive boat speed;
- 6) incoherent value for the made good distance (ADCP versus other equipment: map, laser device).

d) At the commencement of the first transect, the operator should station the boat or flotation device as close to the start bank as feasible for the operation of the ADCP. While the boat is stationary, the operator should start the transect software. At this point, the operator is beginning the discharge measurement and should undertake the following.

- 1) The distance to shore should be measured by some suitable means (see Annex B). This is dependent on the nature and size of the channel, but any suitable acceptable surveying technique should suffice (e.g. range finder, tape, marker buoys at fixed reference points).

- 2) The operator should establish that the ADCP is collecting at least two good bins of data using the system's software.
- 3) When the operator is satisfied that accurate data are being collected and the boat or flotation device is in the correct position to start the discharge measurement, the recording should be commenced and continued until 10 good ensembles have been collected. During this period, the boat or flotation device should be barely moving toward centre channel. The boat or flotation device can then be propelled across the channel.
- 4) The time spent to do the edge measurement should be considered case by case. For example, if the edge discharge is less than 1 % of the discharge, it is not necessary to precisely measure the distance to the bank or its shape. In that case, the gauging team can make and record a quick estimate of the edge discharge, distance, and shape. Otherwise, there should be no changes to usual measurement protocol.
- e) Whenever possible, the average boat/flotation device speed should be less than or equal to the average water velocity. In addition, as far as possible, the boat speed should be uniform and smooth. If changes of speed or direction are required, these should be undertaken slowly.
- f) It can be necessary to move the boat faster than the water velocity if it is the only solution to provide a regular path in speed and rotation. In that case, the number of transects should be increased to compensate for the higher boat velocity. This is particularly true when water velocity is very low.
- g) All relevant information concerning the gauging should be recorded on the field sheets during the measurement process. This information can include reasons for not being able to maintain a boat speed less than the mean water velocity, estimated wind speed and direction, bi-directional or unusual flow patterns, passing boat movements and reasons for terminating a transect.

5.3 Method dealing with moving-bed condition without GNSS system

5.3.1 General

It is better to avoid gauging sites with a moving bed, but it might not be possible to find an alternative site and prepare GNSS system. In such condition, discharge biased by the moving-bed condition shall be modified with a bed load velocity. For this purpose, there are two methods to obtain the bed load velocity, such as the stationary moving-bed method (see [5.3.2](#)) and the azimuth method (see [5.3.3](#)). After the bed load velocity is obtained, the discharge can be obtained using subsection correction method (see [5.3.4](#)). Another option is the loop method (see [5.3.5](#)), it enables to measure discharge including the bed load velocity. Therefore, the bed load velocity by the stationary moving-bed method, and the azimuth method can be used to double check. In order to conduct the azimuth and loop method, an internal compass is essential. If the ADCP does not have a compass or if the compass cannot be calibrated sufficiently, mid-section method (see [5.3.6](#)) should be used.

5.3.2 Stationary moving-bed method

The vessel used to make the stationary moving-bed method should be held in a stationary position for a minimum of 5 min if the boat is tethered or anchored, otherwise it should be held for a minimum of 10 min. If it is not possible to hold a boat absolutely stationary, a note should be made of the movement of the boat and allowance for the same made while examining the results. While in a stationary position, the ADCP data should be recorded and examined for any apparent movement relative to the channel bottom. If apparent movement is measured, the water velocity and direction of movement measured by the ADCP and the discharge determined by the ADCP will be incorrect.

Various methods for holding the ADCP stationary have been tested. Conclusions made from a moving-bed test are only as good as the accuracy of the positioning method. Tethers, tag lines, anchors, or buoys are effective methods for holding a boat on station.

NOTE The duration to do for this stationary test depend on two factors: bed velocity and boat stability.

In the moving-bed test, the bed velocity is estimated by dividing distance with duration. Then the uncertainty of the real position of boat will be very small relative to the made good distance. If the boat position is known at ± 10 m, the duration will be higher than if the position was known at ± 1 m; then team gauging should estimate the bed velocity and its uncertainty on site to choose the best duration.

Another criterion is to have few bad ensembles and not at the same time otherwise the ADCP made good distance can be wrong. This should be analysed for each case.

5.3.3 Azimuth method

The azimuth method is based on the azimuth moving-bed test. Fixed start and stop markers should be established. The distance between these markers should be measured accurately. A single measurement should be taken between the starting and stopping markers. The distance the ADCP believes it has moved upstream should be calculated and divided by the duration of the measurement to calculate the bed velocity. (see [Figure 9](#)) This value can be used to adjust the measured velocity and discharge as for the loop and subsection methods.

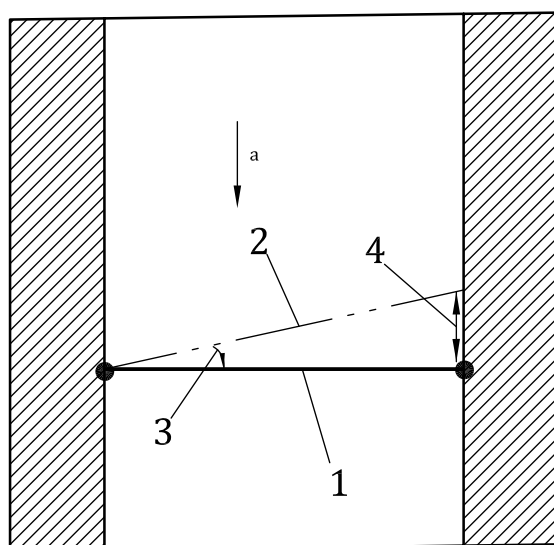

Key

- 1 true course
- 2 apparent course
- 3 angle between 1 and 2
- 4 apparent distance
- ^a Direction of flow.

Figure 9 — Azimuth method

The measured values are the lengths of the true course and the apparent course. The angle between these two paths can be calculated and used to calculate the apparent distance, and thus the bed velocity.

5.3.4 Subsection correction method

For the subsection correction method, multiple moving-bed tests are made at different locations in the measurement cross section. The bed velocity is calculated for each of these tests as the apparent movement of the ADCP divided by the length of the test. It is important that the ADCP be kept stationary for the tests. A discharge measurement is undertaken using bottom tracking as the velocity reference and the mean measured water velocity for each subsection to be calculated. A corrected mean velocity

can be calculated by adding the bed velocity. As for the loop method, the corrected discharge can be calculated for each portion (subsection) of the cross section by [Formula \(6\)](#):

$$Q_c = \frac{\bar{v}_c}{\bar{v}_{ms}} Q_{ms} \quad (6)$$

where

- Q_c is the corrected subsection discharge;
- \bar{v}_c is the corrected mean subsection velocity ($= \bar{v}_{ms} + \bar{v}_{mb}$);
- \bar{v}_{ms} is the mean measured subsection velocity;
- Q_{ms} is the measured subsection discharge.

NOTE Use of the ratio of velocities does not account for the fact that the cross-sectional area is distorted by the moving bed. With a severely moving bed, this can result in an overcorrection of the measurement.

5.3.5 Loop method

The loop method is based on the fact that as an ADCP is moved across the stream, a moving bed will cause the bottom-track based ship track to be distorted in the upstream direction. Therefore, if an ADCP makes a two-way crossing of a stream (loop) with a moving bed, the bottom track-based ship track will show that the ADCP will have returned to a position upstream of the original starting position (see [Figure 10](#)). As the ADCP appears to have moved upstream, the water velocity measured by the ADCP will be biased low and, consequently, the discharge will also be biased low. If the moving-bed velocity can be determined, then the discharge excluded from the measurement caused by the moving bed can be estimated and added to the measured discharge to obtain the corrected discharge, as show in [Formula \(7\)](#):

$$Q_{TC} = Q_{TM} + Q_{mb} \quad (7)$$

where

- Q_{TC} is the discharge corrected for the moving-bed bias;
- Q_{TM} is the measured discharge in bottom tracking mode without GNSS;
- Q_{mb} is the discharge correction to account for velocity bias from the moving bed.

A starting marker should be established on the channel bank and the ADCP compass calibrated as per the manufacturer's manual. A loop should be made all the way across the channel and back to the starting marker (see [Figure 10](#)). The velocity of the moving bed can be calculated by dividing the apparent distance moved upstream by the time taken for the loop. See [Formula \(8\)](#):

$$\bar{v}_{mb} = \frac{D_{us}}{t} \quad (8)$$

where

- \bar{v}_{mb} is the mean bed velocity;
- D_{us} is the apparent distance moved upstream;
- t is the time taken for the loop.

The cross-sectional area is then computed perpendicular to the mean flow direction. If this is multiplied by the mean bed velocity of the moving bed, the discharge not accounted for due to the moving bed can be estimated as shown in [Formula \(9\)](#):

$$Q_{mb} = \bar{v}_{mb} A \quad (9)$$

where A is the cross-sectional area perpendicular to the direction of flow.

The discharge missed by the moving bed obtained from [Formula \(9\)](#) above can then be entered into [Formula \(7\)](#) to determine the corrected discharge.

It is important that the cross-sectional area be computed perpendicular to the mean direction of flow. If the cross-sectional area is computed parallel to the ship-track measured by the ADCP, then it will be computed on the basis of a ship-track that is distorted in the upstream direction by the moving bed. This will result in a cross-sectional area that is too large.

The above method is referred to as the “mean correction loop method”. It is straightforward to compute and research has shown that it can provide reasonable corrections for many ADCP gauging situations. However, if the cross-sectional-area, discharge and moving-bed velocities are not reasonably uniform, the mean correction loop method will improperly weight the discharge throughout the cross section. Therefore, a better, but more complex, “distributed correction loop method” is sometimes preferred (see Reference [\[44\]](#)).

It is important when using this method to have a well-calibrated compass. If the ship track plot indicates movement in the downstream direction, there are three possible reasons:

- a) the compass is not well calibrated;
- b) the operator did not return to the starting position; or
- c) there were many bad ensembles (boat velocity measurements).

Note that as stationary test, even if the compass is correct or not, the user should check for bad ensembles. A lot of bad ensembles can lead to have bad estimation of this distance (shiptrack with erratic values).

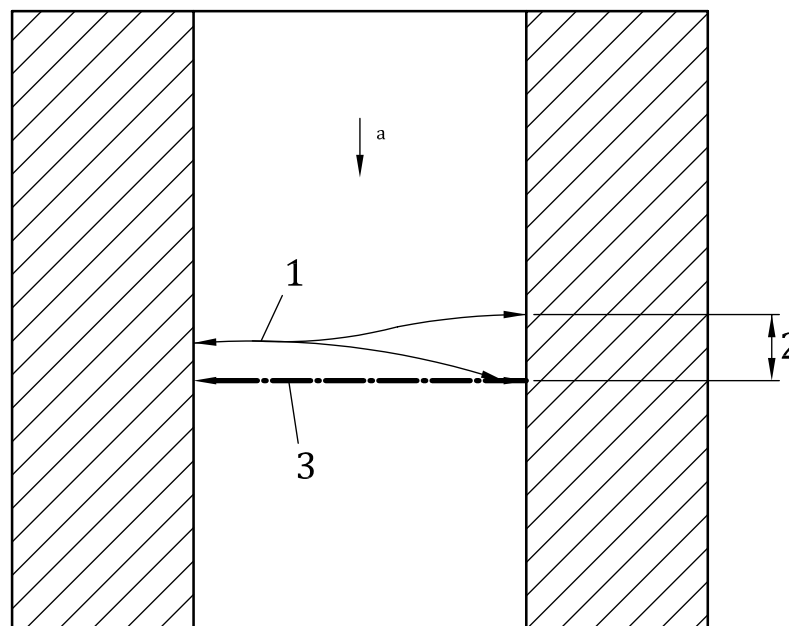

Key

- 1 apparent transect lines
- 2 distance upstream
- 3 true transect lines
- a Direction of flow.

Figure 10 — Effect of a moving bed on ADCP position monitoring and the paths travelled by the ADCP during a loop moving — Bed test

5.3.6 Mid-section method

Use the ADCP as a stationary velocity profiler with the stationary moving-bed method to collect velocity profiles at selected locations across the channel. The number of verticals depend on channel width and should be selected according to the guidelines for conventional current meter gauging. The average velocity should be computed for each profile and the discharge calculated using standard techniques as for a conventional current meter gauging (see ISO 748).

It is important that the ADCP be kept stationary as there is no correction for ADCP movement. Tethers, tag lines, anchors, or buoys are effective methods for holding a boat on station. This technique does not measure as much of the cross section as the standard ADCP technique, but more of the water column is sampled than for conventional current meter gauging. If the system has a built-in compass, the ADCP can be used without introducing errors. If there is no system compass, then it is critical to ensure that the ADCP is deployed perpendicular to the cross section without any movement during the measurement. If this is not possible, the direction of the ADCP relative to the direction of flow should be determined. This is similar to the principles applicable to conventional current meter gauging from a suspension cable. There are other occasions that stationary deployment may be used when there is ice on water surface and the objective is to measure through holes in the ice.

6 Site selection

6.1 General

The ADCP is a device for measuring velocity, direction and cross-sectional area. As such, it is a velocity area device and the criteria for site selection do not differ from conventional current meter methods given in ISO 748. However, in view of its technology, it can cope with irregular velocity distributions

and skewed flow conditions. As such, the choice of the measuring cross section is not as critical as with other velocity-area methods. The site requirements such as minimum depth and velocities are largely dependent on the transducer frequency and the mode of operation (how the ADCP processes the acoustic signals and what set up parameters are used). Further guidance should be available from the manufacturer's instruction manual. The following considerations should, however, be kept in mind.

- a) Velocities to be measured should be greater than the minimum response speed of the sensor and less than the maximum. (Refer to the manufacturer's manual.)
- b) Reflectors such as suspended solids or vegetation detritus should be available in the water under the full range of flows to be measured in sufficient concentration for an adequate velocity signal to be produced. (Refer to the manufacturer's instruction manual.) Air bubbles will act as reflectors but, in general, should be avoided.
- c) Sites where excessive aeration, turbulence, or high sediment concentration occurs should be avoided.
- d) Sites with large rocks and steep edges should be avoided.
- e) There should be minimal thermal gradient in the water column. Although a thermal gradient will not affect the measured velocity values, the algorithms used by the ADCP to estimate the flow rate through the unmeasured areas becomes biased by unknown amounts.
- f) Sites with excessive vegetation growth, including seaweed if used in estuaries, should be avoided.
- g) Sites with substantial vertical velocity should be avoided.
- h) The measurement of outflows from lakes can be difficult due to lack of suspended materials, especially after periods of low rainfall.

6.2 Site-selection criteria

The following additional site-selection criteria may be used as a guideline, based on the use of an ADCP designed for the minimum limits of application.

- a) It might be desirable to select the section, whose velocity and turbulence are less in order to minimize the uncertainty because of the turbulent flow as well as to ensure safety. Selection of a boat, which has less oscillation and has capability to measure in high speed conditions, is helpful to improve safety and to reduce uncertainty in the measurement.
- b) The faces of the transducers are susceptible to serious damage if they are struck heavily by a hard object. Therefore, the measuring section should be free of rocks, tree stumps and other objects in shallow water.
- c) The minimum water depth for deployment depends on the model of ADCP and the settings available (i.e. bin size and blanking distance), so reference should be made to the manufacturer's manual. It is important to check that any claims made by the manufacturer allow for at least 3 depth cells plus blanking distance, transducer depth and unmeasured area at the bed. A minimum of two measured bins is recommended at the edges. However, for the majority of the cross section, a minimum of three cells will be required in each ensemble, in order to allow extension of the velocity profile into the unmeasured sections of the water column.
- d) An appropriate ADCP for the river depth should be used (see the manufacturer's manual).

If bottom tracking is to be used, sites with moving-bed conditions should be avoided if possible. However, if the method dealing with moving-bed condition can be used, the ADCP may still be the best method or at least a good alternative (see [5.3](#)).

7 ADCP Deployment procedure

7.1 Deployment techniques

7.1.1 General

The ADCP transducers should be mounted below any potential interference effects from the hull (underside) of any boat. The configuration and deployment should maximize the percentage of the water column that can be measured without compromising the ADCP limitations, including flow disturbance limitations.

7.1.2 Manned boat mounted

If the ADCP is fixed to a manned boat, the fittings should be of non-ferrous materials and designed so that the position of the ADCP can be vertically adjusted, i.e. the boat fittings should allow the transducers to be fixed at different depths relative to the water surface. They should allow the easy installation and fixing of the ADCP to the boat. The ADCP need not be permanently fixed to the boat. Or tethering a tethered boat with the manned boat is also one of the options. Care should be taken in order for ADCP to measure flow without any disturbance created by the boat; e.g. propeller wash, or bow wave. In addition, a magnetic field causes poor observational results, since it disturbs the internal compass of the ADCP. Engines is one of the large sources of the magnetic field. ADCP shall be located separately from the engines. Furthermore, any material can be the magnetic field. If the elimination of such material is impossible or no magnetic field can be guaranteed in any way, the deployment of a GNSS compass (see [7.5.3](#)) can be considered; if not, it is necessary to make sure that the stream bed doesn't move. For example, if from prior experience the gauging team knows that for low velocity there is no moving bed, then no systematic moving-bed test has to be done. Even so, if the compass doesn't work properly, the discharge will be good but not the shiptrack.

NOTE Experience has shown that a long length of coiled ADCP power cable (36V) produced magnetic interference, which distorted the compass measurement. In this case, the discharge was correct but not the shiptrack.

7.1.3 Tethered boat

7.1.3.1 General

The ADCP can also be deployed on a small floating platform, which can be tethered to a boat or cableway or walked along a bridge for transport across a river. This allows movement of the ADCP for optimal positioning during a deployment. A tethered boat deployed from a manned boat should not be located downstream of the manned boat.

Some tethered-boat ADCPs can operate in shallow waters that can be waded safely, which is an alternative deployment method in those cases. Care shall be taken so that the presence of the operator does not impact flow conditions near the ADCP.

In particular when the water surface is rough and fast, it is recommended to employ a tethered boat, which is specially designed for a high speed and rough condition. The ADCP cannot measure with reliability when the boat is jumpy or overly inclined; i.e. more than 15° in both pitch and roll. The deployment of this kind of boat avoids missing or invalid ensembles in each transect.

7.1.3.2 Bank to bank rope deployment

Use of a tethered boat and tow rope is the simplest and most efficient method for deploying the equipment at many gauging sites. The equipment needed is simple — two ropes that will stretch across the section and the flotation platform. One operator shall be able to cross the river with the end of a rope. It may even be possible to set up a pulley system with a single loop of rope. If the ADCP is to be deployed from a bridge, it may be possible, depending on site conditions, to use a single rope (see [7.1.3.4](#)).

This method is suitable for smaller rivers or canals, and sites with lower velocities. Very high velocities may cause the operators to be dragged into the water, or the tethered boat may dive or capsize.

7.1.3.3 Cableway deployment

Existing cableways normally used for conventional current meter flow measurement can be used to deploy the ADCP. At these sites, it is a highly effective and efficient deployment method as no additional equipment is needed other than the tethered boat. If this method is used, the suspension cable should be slack enough to ensure the boat is resting on the water surface so that the transducers remain at constant depth. The suspension weight used to maintain tension and to overcome the sag of the cableway should be kept clear of the water surface to avoid turbulence around the ADCP.

7.1.3.4 Bridge deployment

A bridge over the river is one of the good options. In this case, a boat is tethered with ropes or hand line or, in a similar manner to that of a conventional current meter, using a bridge-gauging derrick.

7.1.4 Deployment on a remote-control craft

Deployment of the ADCP on a remote-control platform is the preferred option where there is no cableway or bridge and no way for the operator to cross the river. ADCP operators using remote-controlled boat deployments should have a contingency plan for retrieving the ADCP if control of the boat is lost.

7.1.5 Data retrieval modes

ADCPs can be used in two ways.

- a) The first method is to record data in real-time mode. The equipment stays in communication with the computer throughout the gauging process and the data are processed and displayed on the computer screen as they are recorded.
- b) The second method is to set the ADCP to record data in the self-contained/autonomous mode. The ADCP records the measurements internally and the data are downloaded later. This is not recommended, but required on wide rivers when wireless communication between laptop and sensor exceeds transmission limits, when wireless communication fails, and when the manned boat cannot be used

Since the data will be recorded as one continuous set and it may be difficult to identify the end of a transect. Therefore, care should be taken to note the time at either end of each transect. It is also useful to pause at the end of each crossing for 30 s to clearly identify the end of a transect, so that measurements taken during each transect can be distinguished from other transects. The ADCP should be synchronized with the timing device used to record the transect start and finish time.

A separate portable power source or spare batteries may be necessary to power a laptop when running the ADCP in real-time mode, as laptop batteries may not last a full day's gauging.

7.2 Operation of boat

7.2.1 Boat path

In order for the ADCP to measure discharge, two points (such as starting/ending points and the boat pass) shall be fixed by users depending on the targeted cross section of the gauge station. The selection of the boat path depends on whether the boat velocity is appropriately measured, and an appropriate commercial software are available. With the boat velocity's fully monitored condition, it is not necessary for the boat to follow exactly same path, as long as the boat path starts and ends on the points. When using commercial software, discharge values can be obtained by using the flow velocity data and the boat path data. Theoretically, it can be possible to have a same discharge values, though it is not always the case in the field, since uncertainty of each single measurement can change depending on the boat path.

If such software is not available, it is helpful if the boat follows the same path on each outgoing and incoming crossing of the river. Curved and looped paths also produce acceptable discharge measurements, but detailed data from looped paths can be difficult to interpret.

7.2.2 Boat speed

Ideally, the average speed for each transect should be less than or equal to the average water velocity (for a reasonably wide river ± 30 m width, transect time should be at least 2 min). However, it is more important to have a smooth transect. Where safe and practicable, a non-ferrous tag line can be used to allow more control over boat speed when making low-velocity measurements. Under certain conditions, it may not be possible to keep the boat speed less than the water velocity. It is better to have a higher boat speed and a smooth transect, than a low and uneven boat speed. If this is the case, additional transects should be made to ensure the measurement quality is not degraded. When using GNSS, it is very important to keep the boat speed as low as practical because errors in compass calibrations are additive and will increase with boat speed.

NOTE If there is low velocity, then it can usually be assumed that there is no moving bed. Then it is better to process the ADCP discharge without GNSS even if GNSS was connected to localize the transect. Indeed, in the beam coordinate (without GNSS), boat speed and water velocity are properly oriented: this is the condition for a good discharge.

7.3 Field procedures

7.3.1 Pre-field procedures

Prior to going into the field to undertake ADCP deployments, the following pre-field procedures should be undertaken to avoid wasted journeys and delays and to ensure the quality of the data.

- Ensure that up-to-date software and firmware are being used for the data collection and processing. Software updates should be evaluated and when appropriate be installed on all field computers to be used. Additionally, it is good practice to store the software on a separate storage media in case the computer is damaged or lost.
- All equipment including ancillary items such as distance measurement devices, should be assembled and checked. A pre-field equipment check should be done to make sure that all the required equipment is assembled. An example of such a check list is shown in [Annex C](#).
- All cables, batteries and mounts should be checked.
- The ADCP should be connected to the field computer and all communications including radio modems, if these are to be used, should be checked.
- Any other ancillary equipment to be used, which will be connected to the ADCP in the field, such as echo sounders and GNSS, should also be connected and checked.

7.3.2 Field setup

The following field setup should be conducted.

- a) Required ADCP diagnostic checks should be undertaken in accordance with the manufacturer's recommendations and any local procedures, if the ADCP has not been used for many weeks or if the pending measurement is a strategic. It is recommended that these tests are undertaken from a stationary boat in still water.
- b) File names for the data files collected (also called deployment names) should follow a uniform, documented convention developed by each organization involved in the ADCP operation.
- c) After the ADCP is mounted and deployed on the flotation device, the transducer depth should be manually measured and recorded. The transducer depth is the vertical distance from the water surface to the centre of the transducer faces. The depth should be recorded in the ADCP discharge-

measurement notes and entered into the configuration file. If an ADCP has transducers with centre lines at varying depths, consult the manufacture for the transducer depth reference point. When measuring the transducer depth, it should be ensured that the roll and the pitch of the flotation device are similar to the roll and pitch experienced during the discharge measurement. An error in the ADCP depth measurement can result in a significant error in the channel depth, the extrapolated discharge at the surface and the resulting total discharge.

- d) Particular care should be exercised when measuring transducer depth while on a boat to ensure personal safety when working at the edge of the boat, as many boats may list when personnel are not centred in the boat. This can produce an error in the transducer depth measurement.
- e) If possible, a pre-calibrated mounting bracket should be used to ensure that the equipment is fixed at a known transducer depth. It is essential that the bracket is set correctly when mounted on the boat or flotation platform and the ADCP set correctly in the bracket. However, care should be taken to ensure that due allowance is made for any change of load in the boat such as fuel, personnel and equipment, which can cause the transducer depth to change.
- f) As explained in c) and d), there are several chances that the depth of ADCP changes. If it changes during the measurement, the depth shall be measured again, noted, and the configuration file modified with the new depth during post processing.
- g) As temperature is the most important parameter in the equation used to estimate the speed of sound, it is good practice to check the ADCP's temperature measurement with an independent sensor. The independent temperature measurement should be made at the same place as the ADCP.
- h) If operating in waters where the salinity can be higher than normal freshwater (e.g. estuaries), the salinity should be measured near the ADCPs transducers and the value entered into the ADCP's software.
- i) The ADCP's clock should be checked and set to the correct time or to the same time zone as the gauging station recorder.
- j) Many ADCPs resolve boat and water velocity direction relative to an inbuilt compass. It is important that this compass is correctly calibrated, when using GNSS as reference, and when using the loop method (5.3.5) or azimuth method (5.3.3). The compass calibration procedure will be particular to each ADCP make. Reference should be made to the manufacturer's manual.
- k) The ADCP should be configured by a trained user to reflect the hydraulic and hydrological conditions at the site and to optimize the data quality. ADCP configuration parameters that shall be set include the blanking distance, water mode (if applicable), depth-cell size, and profiling range. Other parameters that should be set prior to data collection, but which can be modified during post processing, include the ADCP draft, edge shape, top and bottom extrapolation method, and magnetic variation. Configuration parameters are specific to the type (narrowband or broadband), the manufacturer, and the model of the ADCP being used. For a detailed description of all configuration parameters, refer to the technical documentation for the specific ADCP.
- l) Most ADCP data-collection software contains an automated method to configure the ADCP. The automated methods are dependent upon user-supplied information about site characteristics, such as maximum water depth, bed-material characteristics, and expected maximum water and boat velocity.
- m) The configuration parameters and the site conditions entered into an automated configuration program should be documented in the field notes. Changes made to the ADCP configuration during a measurement should be documented on the measurement field note forms so that it is clear that changes were made and clear which transects these changes apply to.
- n) Manual configuration of an ADCP should only be used in rare cases where the automated procedures are not applicable. The most up-to-date guidelines for the ADCP should be understood before attempting a manual configuration. If guidelines are not available, the user should use manufacturer's recommendations for the unit.

- o) Configuration of the ADCP to collect single-ping water data are preferable, if random noise levels do not prohibit this configuration. Collection of single ping data allows possible data-quality problems to be more easily identified than problems with multi-ping averaged data. When collecting multi-ping averaged data, the user should be aware of how often the heading, pitch, and roll sensors are recorded and how often water depth and boat velocity are measured. If the averaging interval is too long for the boat stability and water turbulence, errors can be introduced into the measurement.
- p) Wind speed can be important, especially for sites with low velocities where wind can greatly affect the surface velocities and influence the top extrapolation method to be applied. In this case, overall wind speed and direction, as well as changes between transects, should be noted on all measurement field note forms to assist with accurate processing and reviewing of measurements.
- q) If the user is unfamiliar with the measurement section, a trial transect, which may or may not be recorded, should be made across the river. A trial transect is useful for determining the following characteristics of the proposed measurement:
 - 1) maximum water depth;
 - 2) overall cross-sectional shape;
 - 3) maximum water velocity and its location in the cross section;
 - 4) flow uniformity;
 - 5) effects of hydraulic structures, such as bridges, piers, and islands, on the flow;
 - 6) unusual flow conditions, such as reverse or bi-directional flow;
 - 7) bank shapes;
 - 8) approximate start-and-stop locations on the left and right banks, where a minimum of two depth cells with valid velocity measurements can be measured. (To obtain consistent edge estimates, buoys can be used to mark the start-and-stop locations);
 - 9) presence of debris or vegetation in the cross section.

The information gleaned from the trial transect should be recorded on the discharge-measurement notes.

- r) It is important that the data files collected follow a uniform convention. An ADCP measurement field sheet should be used to record all pertinent site information, configuration set-ups and other gauging details. Any changes to the configuration set-up made during a measurement should be recorded clearly stating to which transects the changes apply. Examples of field sheets are shown in [Annex D](#).
- s) High water velocities and small-grained bed material are one indicator that a moving-bed test should be performed (see [5.3](#)). A moving-bed test should always be carried out and recorded prior to making any discharge measurements. This is due to the fact that the discharge can be underestimated if the bed is moving downstream in a river (and possibly the opposite if moving upstream in an estuary with incoming tides), since the ADCP will underestimate (may over estimate in estuary) the velocity if the bed is moving. The results should be used to decide on the location of transects and to adjust any discharge measurements (if necessary). There are various methods for undertaking a moving-bed test.
- t) The extrapolation method for the top and bottom unmeasured zones shall be specified unless the extrapolation methods default to the one-sixth (0,166 7 power coefficient) power law on the top and bottom for data collection. Often, the appropriate extrapolation method cannot be determined until after the measurement during post processing. Previous data collected at a site may be used to guide the selection of the extrapolation method. In the absence of any other information, the one-sixth power-law extrapolation method is a good technique for most open-channel discharge measurements made during steady-flow conditions. The extrapolation methods should be evaluated and, if necessary, changed during post-processing.

7.3.3 Reviewing ADCP data during measurement

When processing ADCP measurements, measured and processed data should be carefully reviewed. Listed below are the most common problems found when reviewing ADCP data:

- no moving-bed test carried out;
- edge distances not measured accurately enough;
- edge shape not observed correctly (i.e. rectangular, triangular);
- bad cells;
- bad ensembles;
- uneven boat speed;
- boat speed too fast;
- excessive boat rotation;
- incorrect number of depth cells;
- poor field notes;
- poor data-archival procedures;
- incorrect blanking distance;
- use of ferrous metal mounts.

7.3.4 Post measurement requirements

An assessment of the discharge measurement should be made after completion of the transects composing the measurement. A thorough review of all measurement data are often not practical in the field, but a cursory review of the measurement should be made to make certain that there are no critical data-quality problems with specific transects. If all transects were collected at the same measurement section, the transect widths and discharges in the measured (middle) and unmeasured (top, bottom, and edge) sections should be consistent. If transect widths or discharges are not consistent with the other consecutive transects, the transect data should be scrutinized to determine if a critical data-quality problem occurred. These checks should be done on site if it was necessary to do another pair of transect.

If a critical data-quality problem is identified, the data from that transect should not be used in the computation of discharge. A new transect should be collected, starting from the same side as the discarded transect, if flow conditions have remained steady. If the flow has changed, a new transect series should be collected. A transect should only be discarded if a critical data-quality problem is identified.

All the files in a discharge-measurement series should be identified uniquely. Immediately after completion of a measurement, all files including raw data files, configuration files, ADCP test files, compass calibration files, and any electronic measurement forms should be backed up on a non-volatile media such as CD-ROM, flash-memory card, or USB drive and stored separately from the field computer. The purpose of this backup is to preserve the data in the event of loss or failure of the field computer.

The ADCP should be dried after use and if possible stored in its protective case for transport. When working in estuaries and other salt-water environments, the ADCP should be rinsed with fresh water and dried prior to storing for transport. Failure to dry the ADCP may result in corrosion of the ADCP connectors, mounting brackets, and any accessories stored in the protective case. In addition, care shall be taken to prevent transport of biological materials between ecosystems, including following any precautions regarding invasive species of organisms, such as draining of bilge waters.

7.4 Ancillary equipment

[Table 1](#) provides an indicative list of the additional equipment. In addition to the ADCP, connecting cables and field computers, other ancillary equipment and field aids may be required. The use of such equipment is beyond the scope of this document. Where appropriate, the user should refer to standards that deal with this equipment.

Table 1 — Ancillary equipment and other filed items

Equipment or Item	Function
Distance measurement devices such as surveyor’s tape and a laser range finder	Measure distances from the first and last measurements to the banks
Thermometer	Measure water temperatures
Salinity/conductivity meter	Measure salinity
Wind speed meter	Estimation of wind speed
Back-up memory devices such as a USB memory stick	Field back-ups of data
ADCP field sheets	Recording site and transect details, etc.
Set of suppliers’ ADCP tools	Simple servicing/repairs
Hand-held radios	Tethered flotation/unmanned boat applications
Digital multimeter	Electronics troubleshooting

7.5 Other consideration

7.5.1 Edge distances

Edge distances for estimation of edge discharge, should be measured using a tape measure, an electronic distance measuring device, a tag line, or some other accurate measuring device. Visual estimation may be enough if the width and velocity on edge are very low regarding discharge measured. The shape of the unmeasured part of the transect should be noted and input to the configuration. Edge distance and shape information should also be noted manually.

While measuring in channels with vertical banks side-lobe interference and different runtimes of the ultrasound signals (earlier reflection at vertical bank than channel bed) can lead to poor data acquisition. A minimal edge distance depending on the angle of the ADCP transducers and the water depth can be approximately calculated by [Formula \(9\)](#):

$$\tan(\theta) \times D \tag{9}$$

where

θ is the beam angle;

D is the water depth.

7.5.2 Depth measurements at sites with high sediment concentrations

ADCPs may not measure depths accurately in deeper streams with high sediment concentrations and/or high bed load transport. In these instances, it can be necessary to use a depth sounder. The sediment concentration or bed load transport rate at which it becomes necessary to use a depth sounder will vary between different manufacturers of ADCPs and is not presently known. If a “moving-bed condition” exists at the measurement site, it is recommended that several trial measurements be made using a vertical depth sounder, under a variety of flow conditions, to determine if the ADCP determined depths are sufficiently accurate. If an echo sounder is used, its accuracy needs to be established and it should have been satisfactorily calibrated. When using an echo sounder, it will also be necessary to use a GNSS.

7.5.3 GNSS compass

A GNSS compass consists of two GNSS antennas that determines an orientation for vectors of ADCP movement. An advantage of GNSS compass is that it is not affected by a magnetic field. Therefore, it is more reliable to deploy a GNSS compass when a magnetic field exists at points of measurement or when the ADCP is mounted on a boat made of steel.

7.6 Maintenance and ADCP checks

7.6.1 General

In order to properly operate an ADCP measurement, maintenance and ADCP checks should be carried out.

7.6.2 Built-in diagnostic check

Most ADCPs are capable of running built-in diagnostic checks. A combination of firmware and software can be run to verify that various ADCP systems are functioning properly and the ADCP is responding. These checks should be carried out invariably at the beginning of each field day. Key checks are made for Central Processing Unit tests, Digital Signal Processor tests, beam operation, sensor tests and battery condition. If diagnostic-test information is not available for a specific ADCP, the user should contact the manufacturer for guidance.

7.6.3 Periodic major service in the manufacturer

A periodic major service includes checks of pressure case, electronics and firmware. It is recommended to maintain full functionality, performance and accuracy. It should be done in the manufacturer.

7.6.4 Periodic ADCP performance check

Periodic ADCP performance checks help ensure consistency among instruments and discharge-measurement techniques. The check may be made at a site where the ADCP measured discharge can be compared with a known discharge derived from some other source, such as the rating discharge from a site with a stable stage-discharge rating. If the ADCP is equipped with more than one water or bottom-tracking mode, it is desirable, though not essential, to periodically conduct checks by using the different modes. Periodic checks should be performed at different sites, so that a range of hydrologic conditions are reflected in the tests and so that any inherent biases associated with a particular site are minimized. The discharge obtained from the ADCP should be within 5 % of the known discharge, but a consistent bias should be investigated. This is also helpful to detect any unseen defaults. Additionally, not only discharge, but also distance made good (beam-alignment test), depth and temperature are recommended to compare through the check.

If the comparison reference is a stable stage-discharge rating and the ADCP measurement departs from the discharge rating by more than 5 %, it is possible that a rating may have shifted. Another measurement with a second ADCP or an alternative method should be made to check the validity of the rating before drawing definitive conclusions regarding the ADCP test.

If a problem is detected, the ADCP should be send back to the manufacturer.

7.6.5 Physical maintenance

Physical maintenance should be necessary, when an ADCP is subjected to significant physical shock. For this purpose, beam-alignment test is helpful. If a problem is detected, the ADCP should be sent back to the manufacturer.

7.6.6 Beam-alignment test

A common source of ADCP bias is for the beams to be misaligned. The user can evaluate the potential bias caused by beam misalignment by a simple field test for ADCPs which have an internal compass. The

beam-alignment test compares the straight-line distance (commonly called the distance “made good”) measured by bottom tracking to that measured by GNSS. Detailed procedures for the beam-alignment test are provided in [Annex E](#). For other ADCPs, sufficient data have not been collected to validate this criterion; however, the criterion is assumed to be applicable for other ADCPs. If the ADCP does not meet the beam-alignment criterion, the ADCP can be returned to the manufacturer for a custom transformation matrix to be determined and loaded into the ADCP.

7.7 Training

At least one member of an ADCP gauging team should have received formal, detailed training in the operation of the equipment and associated software being used. The other team members should be familiar with field operation of the equipment and the general principles of ADCP gauging.

As ADCP technology is continually changing, it is recommended that users keep up-to-date with these changes. Arrangements should be made with the equipment suppliers to provide regular updates of software changes, bug fixes and improvements to the equipment and changes in recommended operation practices. Whenever possible, practitioners and users should have access to suitable first-time and refresher training in field use, as well as training for data analysis, processing and quality control.

8 Uncertainty

8.1 General

The uncertainty in a single measurement of discharge is dealt with in ISO 5168, to which reference should be made. Additional information is given in ISO/TS 25377 which includes a possible methodology of dealing with the uncertainties in moving-boat ADCP velocity determinations.

8.2 Definition of uncertainty

All measurements of a physical quantity are subject to uncertainties. These may be due to systematic errors (biases) in the equipment used for calibration and measurement, or to random scatter caused by, for example, a lack of sensitivity of the equipment used for the measurement. The result of a measurement thus is only an estimate of the true value of the measured quantity and therefore is complete only when accompanied by a statement of its uncertainty.

The discrepancy between the true and measured values is the measurement error. The measurement error, which cannot be known, causes an uncertainty about the correctness of the measurement result. The uncertainty is expressed quantitatively as a “parameter that characterizes the dispersion of the values that can reasonably be attributed to the measurand”. The parameter may be, for example, a standard deviation or the half-length of an interval having a stated level of confidence, and that all sources of uncertainty, including those arising from systematic effects, contribute to the dispersion.

The measurement error is a combination of component errors that arise during the performance of various elementary operations during the measurement process. For measurements of composite quantities that depend on several component quantities, the total error of the measurement is a combination of the errors in all component quantities. Determination of measurement uncertainty involves identification and characterization of all components of error, quantification of the corresponding uncertainties, and combination of the component uncertainties. The uncertainties are combined using the statistical rules for combining standard deviations, giving proper consideration to correlations among all of the various sources of measurement error in order to account for both systematic and random errors. The resulting uncertainty values are termed standard uncertainties; they correspond to one standard deviation of the probability distribution of measurement errors.

In some applications, it is necessary to express the uncertainty of a measurement as a band or interval that may be expected to contain a specified fraction of the distribution of values that can reasonably be attributed to the measurand. Such an interval is obtained by multiplying the standard uncertainty by a factor, k , usually in the range 2 to 3, called the coverage factor. The fraction of the distribution

contained by the interval is called the level of confidence. The relation between the level of confidence and the coverage factor depends on the probability distribution of measurement errors.

In this clause, uncertainties are given as standard uncertainties (one standard deviation) and are expressed as percentages of the measured values (relative or percentage uncertainties). If expanded uncertainties are required, the standard normal (Gaussian) distribution is used to determine the coverage factor corresponding to a specified degree of confidence. In particular, expanded uncertainties with a coverage factor of 2 have an approximate level of confidence of 95 %. This is the case with which ISO 25377 deals.

8.3 Uncertainties in ADCP measurements — General considerations

The sensitivity and potential accuracy of an ADCP system varies according to the ADCP and set up and the way it is operated. ADCP manufacturers include values for sensitivity and accuracy in the technical specification for their sensors. It is important to remember that these figures indicate the accuracy of the measured velocity of the reflectors in the sampled section of the water column, not that of the flow measurement. The following should be noted.

- Depth is an important factor in the calculation of flow, thus the accuracy and sensitivity of the depth measurement (however it is carried out) is also important.
- The accuracy and sensitivity with which the ADCP estimates its own velocity and direction of movement (e.g. bottom tracking or GNSS) has a direct bearing on the water velocity estimates.
- Averaging over a longer time period may reduce the random uncertainty.

8.4 Sources of uncertainty

The overall uncertainty is dependent on number of measurements and assumptions, some of which are more significant than others. The ADCP does not make measurements over the entire cross section. Uncertainties need to be estimated for

- the measured region;
- the top unmeasured layer;
- the bottom unmeasured layer;
- the edges.

Sources of uncertainty include, but are not limited to, the following.

- a) Water velocity: The uncertainty in the water velocity in each depth cell is a function of the ADCP frequency, the size of the depth cell, the mode of ADCP operation, the number of beams, the beam angle and turbulence in the water. It will also be influenced by uncertainties in the estimation of the speed of sound in water which is a function of both temperature and salinity. If the speed of sound in water has an uncertainty of 15, this can result in a discharge uncertainty of 3 %.
- b) Bottom track velocity: The uncertainty in boat velocity will be a combination of the ADCP uncertainty and real variations in boat movement (i.e. uneven motion, pitch/roll, etc.). Moving-bed velocity causes errors in the determination of bottom track velocity. How to test and deal with moving beds is covered in [5.2](#).
- c) Depth: The uncertainty in the depth measurement is a combination of the uncertainty in the depth of the transducers below the water surface and the ADCP depth.
- d) Extrapolation of velocity profiles: The top and bottom layer velocities, and thus the discharge is obtained by extrapolation often using a power law. In order to minimize uncertainties, the default profile should be adjusted to fit the measured values in the measured zone as best as possible to minimize the extrapolation uncertainties. In order to minimize the uncertainties, it is necessary to have an accurate depth determination and low uncertainty in the measured portion of the profile.

Velocity profiles may differ from the default due to environmental factors, such as wind, and should be considered in the selection of extrapolation.

- e) Edge discharge: The discharge is extrapolated at each edge where the water is too shallow to measure velocity reliably with the ADCP. Edge discharge is computed using the velocity closest to the edge, the edge distance for each edge, the edge area type by means of a geometric shape and a traditional weighting factor based on velocity distribution theory. In order to minimize uncertainties, it is necessary to have a good determination of the edge distance and the edge velocity and a realistic edge correction factor.

8.5 Minimizing uncertainties

In order to minimize uncertainties, the following is required:

- ensure smooth movement of the ADCP boat/flotation device;
- change speeds and orientation slowly;
- measure edge distances accurately;
- measure transducer depth accurately;
- adapt cell size and blanking distance to reduce top and bottom uncertainties;
- use data from the stationary test to improve the power law exponent;
- take time to obtain sufficient pings at the edges.

Annex A (informative)

Velocity distribution theory and the extrapolation of velocity profiles

The classical form of the velocity profile can sometimes be represented by a parabolic, power or logarithmic equation for a rough boundary. The log law expression is a direct result of relating the shear in a fluid to velocity gradient, using the eddy viscosity. Here, the flow is assumed to be in steady-state, such that the shear stress at any depth is equal to the bed shear. The most general form of the log law takes the form as shown in [Formula \(A.1\)](#):

$$\frac{v}{u^*} = \frac{1}{k} \ln \left(\frac{30z}{k_s} \right) \quad (\text{A.1})$$

where

- v is the velocity;
- u^* is the shear velocity;
- k is the von Karman constant = 0,41;
- z is the flow depth;
- k_s is the Nikuradse equivalent-sand-grain roughness.

The Nikuradse equivalent-sand-grain roughness is a function of the shape, height width of the roughness elements, which approaches the average height of the protrusions for homogeneous bed (see [Figure A.1](#)).

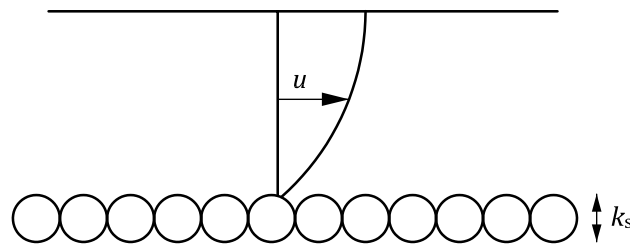

Figure A.1 — Sketch illustrating Nikuradse equivalent-sand-grain roughness

$k_s/30$ can be written as the roughness height, z_0 which is strongly related to Manning's roughness coefficient, n (see ISO 1070). u_* is the shear velocity related to bed shear by the relationship. It is shown as [Formula \(A.2\)](#):

$$u_* = \sqrt{\frac{\tau}{\rho}} = \sqrt{gRS} \quad (\text{A.2})$$

where

- τ is the bed shear;
- ρ is the fluid density;
- g is gravitational constant;
- R is the hydraulic radius (area | wetted perimeter);
- S is the bed slope.

The power law relationship of the form, shown as [Formula \(A.3\)](#):

$$\frac{v}{u_*} = a \left(\frac{z}{z_0} \right)^m \quad (\text{A.3})$$

is useful and has been shown to be directly equivalent of the log law (see Reference [10]) for the constraint that the product $ma = 0,92$. When $m = 1/6$, for steady-state flow, the relationship is equivalent to Manning's formula.

Typically, the log law might be assumed to hold for the entire profile, although strictly should only be used for the lower 20 % of depth. There have been numerous experiments showing how well the log law applies to most of the depth. Clearly, there will be wake type effects near the surface, which retard the flow and give rise to divergence from the log law. However, it has been shown that the log law can be applied to velocity profiles that exhibit the classical parabolic shape. The least squares fitting of power laws to ADCP data can be problematic due to the noisiness of the ADCP profile data. Therefore, a method developed by Chen^[9] using a 1/6th power law [see [Formula \(A.3\)](#)] has been adopted for this purpose. This is an approximation only and different powers from 1/2 to 1/10 can be used to adjust the shape of the curve to try and emulate the physical characteristics of the ADCP measurement site.

The following version of the formula, which is a simplification of [Formula \(A.3\)](#) may be more familiar to hydrometric practitioners. See [Formula \(A.4\)](#)

$$\bar{v} = \left(\frac{c}{c+1} \right) v_y \left(\frac{D}{D-y} \right)^{\frac{1}{c}} \quad (\text{A.4})$$

where

- \bar{v} is the mean velocity for entire river cross section at the site;
- v_y is the velocity at depth y from the surface;
- D is the total depth;
- Y is the depth from the surface;
- C is a constant, often assumed to be 6.

At sites where the classical form of the velocity distribution does not apply (e.g. where bi-directional flow occurs), the above power-curve estimation method will not work and another technique should be used for extrapolation purposes. For example, it is possible to set both the top ADCP discharge estimates to "Constant", which means that the ADCP would use the data obtained from the uppermost bin to estimate the unmeasured part of the profile. The bottom discharge estimates can be obtained in a similar manner.

Annex B (informative)

Determination of edge discharges

The nearshore/bank areas are one of the unmeasured areas by ADCP. It is necessary to determine somehow as explained in [Formula \(3\)](#). It is usually estimated on the basis of an appropriate extrapolation technique. The choice of technique needs to take due account of the conditions at the site and the size of the unmeasured portions.

As one of the examples, the US. Geological Survey and other organizations use a method presented in Fulford and Sauer^[14] which can be used to estimate a velocity at an unmeasured location between the riverbank and the first or last measured velocity in a cross section. This is given by [Formula \(B.1\)](#); also see [Figure B.2](#).

$$\frac{\bar{v}_e}{\sqrt{d_e}} = \frac{\bar{v}_m}{\sqrt{d_m}} \quad (\text{B.1})$$

where

e is the location midway between the bank and first or last ADCP measured sub-section;

\bar{v}_e is the estimated mean velocity at location e (ms^{-1});

\bar{v}_m is the measured mean velocity at first or last measured ADCP sub-section (ms^{-1});

d_e is the depth at sub-section e (m);

d_m is the depth at first or last ADCP sub-section (m).

Fulford and Sauer^[14] defined position m as the centre of the first or last measured sub-section and not the nearshore edge of the sub-section. However, because the ADCP sub-sections are purposely kept very narrow at the start and finish of each measurement the difference between the two applications are not significant. Assuming that the channel is trapezoidal in shape the unmeasured section adjacent to the bank can be assumed to be triangular in shape (see [Figure B.2](#)). Then:

$$V_e = 0,707V_m \quad (\text{B.2})$$

As discharge is velocity multiplied by area, it can then be calculated thus:

$$Q = \frac{0,707V_m Ld_m}{2} = 0,3535V_m Ld_m \quad (\text{B.3})$$

where

Q is the estimated edge discharge, in m^3s^{-1} ;

L is the distance to the riverbank for the first or last ADCP section, in metres.

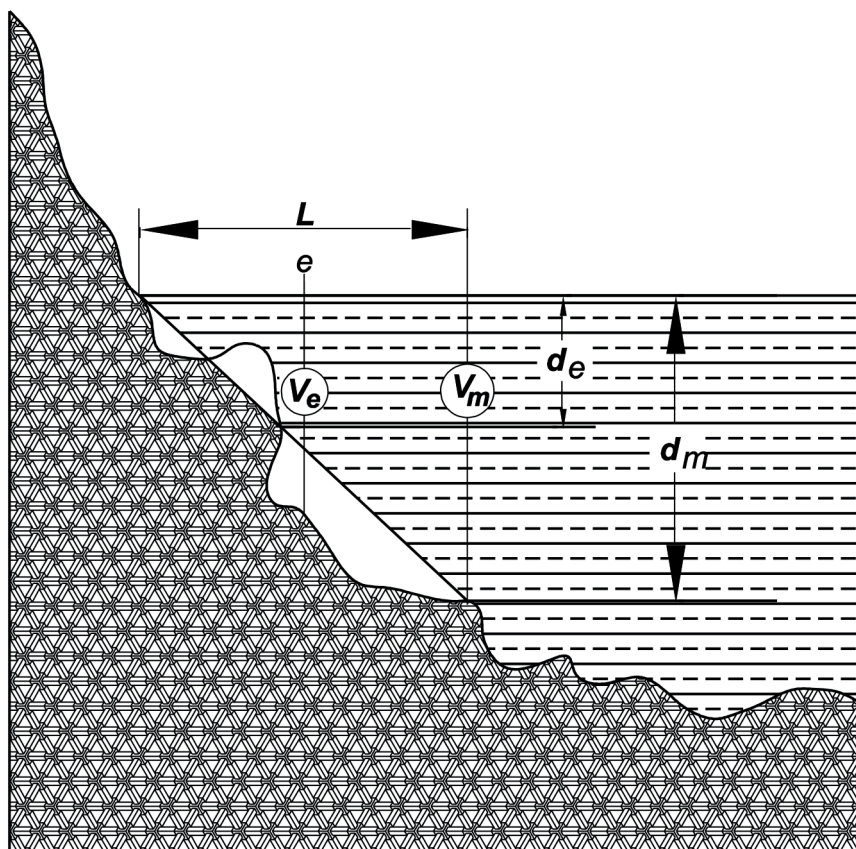

Figure B.2 — Sketch illustrating edge-value estimation

The ADCP software will calculate the depth d_m and the velocity v_m . The distance L is estimated or measured by the operator. [Formula \(B.3\)](#) does not work well in rectangular concrete channels or natural channels with non-standard slopes near the banks. In these instances, a bank slope coefficient can be used to properly depict the channel-bank geometry. For rectangular concrete channels, the [Formula \(B.4\)](#) can be used:

$$Q = 0,91 V_m L d_m \tag{B.4}$$

Annex C (informative)

Example of an equipment check list

Equipment available	Equipment list
	Basic ADCP equipment
	— ADCP with attachments; bolts and nuts
	— ADCP cable(s)
	— Field computer with appropriate software
	— Screen shade/rain protection for field computer
	— Spare 12 V battery with appropriate wiring assembly
	— Power inverters and power strips, if needed
	— Laser rangefinder, or some other distance measurement device
	— Battery charger
	— ADCP measurement toolkit
	— Field note sheets
	— Safety line for ADCP
	Boat deployment
	— ADCP mount
	— Marker buoys
	Tethered/Remote-controlled (RC) boat deployment
	— Tethered boat and harness/RC boat
	— Long rope for use as tether for tethered boat
	— Radio modems and cables
	— Small 12 V-9 A batteries and charger
	— Boat repair kit
	— Sea anchor (for slow velocities)
	— Weight for tether (for fast velocities)
	— Hand-held walkie-talkie type radios
	GNSS deployment
	— GNSS and power/data cables
	— GNSS antenna and cable
	— Pole for mounting GNSS antenna over ADCP
	— 12 V DC battery
	— Spare fuses

Equipment available	Equipment list
	Echo sounder
	— Echo sounder and associated cables
	— Mounting bracket for echo sounder
	— 12 V DC battery
	Useful items
	— General toolbox
	— Thermometer or conductivity/salinity meter
	— Multimeter

Annex D (informative)

Example of ADCP gauging field sheets

D.1 General

An example form for making an ADCP discharge measurement is given as [Figures D.1](#) and [D.2](#). The form is intended for printing as paper size A5, and can be printed as single-sided or double-sided as appropriate for its application. The text can be translated into local languages as needed.

Ref.	Date	Organization				Meas. No.
Station Number		Department				Processed by
Acoustic Profiler Discharge Measurement Notes					Checked by	
Station Name						
Date	, 20__	Party				
Width	Area / Rated Area	Velocity	Index Velocity	Gauge Height	Discharge	
Boat/Motors Used		GNSS Used	ADCP Depth	Gauge Height Change		
				in ____ hr		
ADCP Mfr.	ADCP Model	Frequency	Serial Number	Firmware	Software	
Filename Prefix		Diagnostic Test – Errors?	Moving Bed File		Moving Bed?	
		Y or N			Y or N	
ADCP Sync'd to WT	Meas. Water Temperature	ADCP Water Temperature		Weather		
Y at ____ or N	____ °C at ____	____ °C at ____		Air Temp.	____ °C	
Compass Calibration	Magnetic Variation Used	Magnetic Variation Method		Wind Speed		
Y or N		On-site	Model	Previous	Wind Dir.	
Gauge Readings				Site Conditions		
Time			Inside	Outside	Max. Water Depth	
					Max. Water Speed	
					Max. Boat Speed	
					Water Mode	
					Bottom Mode	
					Stream bed material	
					Salinity	
					____ ppt at ____	
Weighted MGH					Checkbar found	
GH corrections					Checkbar changed to	
Correct GH					at	
Wading, cable, ice, boat, upstr., downstr., side bridge				m upstream, downstream of gauge		
Measurement rated	excellent (2%), good (5%), fair (8%), poor (>8%)				based on following conditions	
Flow						
Cross Section						
Control						
Gauge operating?	Y or N	Record removed?	Y or N	Filename		
Battery voltage	____ V	Intakes / orifice cleaned / purged				
Bubble-gauge	Tank	____ kPa	Line	____ kPa	Bubble rate	____ / min
Extreme-GH indicators	Max.		Min.		CSG Checked?	Y or N
HWM on stick		Ref. elev.		HWM elevation		
GH of Zero Flow		- depth at control		=	____ m	Rated =
				Sheet No.	of	sheets

Figure D.1 — ADCP gauging field sheets — Example 1

The variable fields in red should be completed prior to making functional copies of the form.

Ref. is a unique form number or identifier specified by the responsible organization.

Date is the original or revised date for the version of form being used.

Organization is the parent authority for the department using the form.

Department is the unit responsible for making ADCP discharge measurements.

Acoustic Profiler Discharge Measurement Notes											
Left Bank	Sloping	Vertical	Other: _____	Ending				Right Bank	Sloping	Vertical	Other: _____
				Bank	Time	Distance	Time				
Transect No.	L	R									
	L	R									
	L	R									
	L	R									
	L	R									
	L	R									
	L	R									
	L	R									
	L	R									
	L	R									
	L	R									
	L	R									
	L	R									
Notes											

Figure D.2 — ADCP gauging field sheets — Example 2

D.2 List of acronyms and abbreviated terms

Meas.	measurement
Vel.	velocity
Mfr.	manufacturer
Sync'd	synchronised
Temp.	temperature,
Dir.	direction
ppt	parts per thousand
upstr.	upstream
downstr.	downstream
MGH	mean gauge height
Maximum	maximum
Min.	minimum
CSG	crest stage gauge
HWM	high water mark
Ref.	reference
elev.	elevation
GH	gauge height
L	left
R	right

Annex E (informative)

Beam alignment test

E.1 General

One source of error in ADCP measurements is misalignment of beams in the instrument. This error can be checked and corrected by the user. As one of the examples, the equations for four-beam ADCPs assume that the beams are in perfect alignment and result in nominal transformation matrices for four-beam systems. The nominal transformation matrix for a θ -degree three-beam system is

$$\begin{bmatrix} 1/2\sin\theta & -1/2\sin\theta & 0 & 0 \\ 0 & 0 & -1/2\sin\theta & 1/2\sin\theta \\ 1/4\cos\theta & 1/4\cos\theta & 1/4\cos\theta & 1/4\cos\theta \\ 1/2\sqrt{2}\sin\theta & 1/2\sqrt{2}\sin\theta & -1/2\sqrt{2}\sin\theta & -1/2\sqrt{2}\sin\theta \end{bmatrix}$$

If the beams were misaligned during manufacturing, a custom transformation matrix to correct the misalignment is required. If the wrong transformation matrix is used, the water and bottom-track velocities will be consistently biased. The validity of the transformation matrix stored in the ADCP can be determined by computing the ratio of the bottom-track and GNSS straight-line distances over a long course, provided the ADCP has a compass assuming no bed movement.

E.2 Description of procedure

E.2.1 General

The beam-alignment test is conducted by traversing a long (370 m to 770 m) course at a constant compass heading and speed while simultaneously recording GNSS (GGA or VTG) and ADCP data. The length of the course depends on the accuracy of the GNSS being used. The length of the course should be such that the error in GNSS position is less than 0,1 % of the length of the course. The ratio of the straight-line distance travelled (commonly called the DMG) as measured by bottom tracking with the ADCP and the straight-line distance travelled as measured by the GNSS is computed. This ratio is referred to as the bottom-track-to-GNSS ratio. A reciprocal traverse, which is a course of the same length at a heading approximately 180° from the previous pass, is made and the ratios of the two passes are averaged. This procedure is repeated for a total of four times (eight passes altogether) while rotating the ADCP 45° between each pair of courses. When the bottom-track-to-GNSS ratio is less than 0,995, ADCP measurements most likely have a negative bias error, and when the bottom-track-to-GNSS ratio is greater than 1,003, the ADCP most likely has a positive bias error (Oberg, 2002). A value for the bottom-track-to-GNSS ratio of 0,995 corresponds to a -0,5 % error in bottom-track velocity measurements. A value for the bottom-track-to-GNSS ratio of 1,003 corresponds to a +0,3 % error in bottom-track velocity measurements. The skewed criteria are due to a known potential for ADCPs to have a slight negative bias due to terrain effects. A well-calibrated ADCP should have bottom-track-to-GNSS ratios of approximately 0,998 or 0,999.

It should be mentioned that there is an alternative to the GNSS-based beam alignment test: tow tank test. Tow tank test has become part of the quality assurance test at the US. Geological Survey (USGS) Hydrologic Instrumentation Facility (HIF) since 2014. It is also the standard calibration method used by ADCP manufacturers. Detailed discussion on the tow tank procedure can be found in Reference [6].

E.2.2 Step-by-step procedure

The following procedures should be followed when conducting the distance tests.

- a) Conduct internal ADCP diagnostic tests (if available).
- b) Lower the ADCP into the water, noting which beam is facing forward.
- c) Using the data-collection software, begin pinging, but do not begin recording data.
- d) Open a window in the software that will display the bottom-track-to-GNSS DMG ratio.
- e) Bring the boat to a constant speed and heading and note the heading. The speed should be fast enough to traverse the course in a reasonable time but not so fast as to cause invalid bottom-track data.
- f) Once the boat is at the desired speed and heading, begin recording data. After travelling a minimum of 1 300 m, record the bottom-track-to-GNSS DMG ratio, stop recording, then slow the boat and turn to a heading 180° from the previous heading.
- g) Bring the boat to a constant speed. Record data for this reciprocal pass. At the end of the pass, record the bottom-track-to-GNSS ratio again. It is important not to slow the boat or change heading until recording is stopped.
- h) Repeat this procedure while rotating the ADCP 45° between each pair of courses until the ADCP has been rotated four times.
- i) Average the bottom-track-to-GNSS DMG ratio for each reciprocal pair.
- j) Review the averaged bottom-track-to-GNSS DMG ratio for all rotations and verify that all values are between 0,995 and 1,003, or within the bottom-track accuracy specification provided by the manufacturer of the ADCP. If values are outside of this range, have the ADCP serviced by the manufacturer.

Annex F (informative)

Uncertainty evaluation methods

F.1 General

In order to estimate the uncertainty of discharge measurements with ADCPs, several research groups have developed methods. Two approaches can be classified such as the uncertainty propagation methods, and the in situ collaborative interlaboratory methods which enable us in given measurement conditions to use an empirical estimation of the uncertainty of ADCP gauging techniques. The former can be classified in two methods such as one with determining each components of uncertainty and other with implementing Monte Carlo simulations

Regarding the uncertainty propagation method, the Guide to Expression of Uncertainty in Measurement (International Organization for Standardization, 1993) was recommended to adopt by The World Meteorological Organization's Commission for Hydrology. González-Castro and Muste^[19] reported the method for an analysis framework in order to estimate the bias limit in moving-boat ADCP discharge measurements. Thereafter, Kim and Yu^[33] attempted to implement the similar method. They also reported that adoption of the framework is still challenging due to lack of information for calculations. Dramais^[12] introduced a simple and operative method with decomposing the uncertainty into Type A and Type B. García et al.^[15] presented a model in order to obtain the quantitative values for the random errors relating to moving-boat ADCP measurements. Moore^[38] developed the method using Monte Carlo simulations. There are several studies implementing the uncertainty into the velocity-area method, which is also known as the section-by-section or stationary ADCP method (see References ^[11], ^[21] and ^[36]). Uncertainty analysis was implemented on the discharge obtained by section-by-section measurements made with an ADCP (see Reference ^[36]). In their study, an analytical expression was derived and the uncertainty of the total discharge was obtained which was measured in a stream of 7,5 m wide and 0,6 m deep. They also estimate the uncertainty inside of sampling time and error in depth measurement.

F.2 Software

For computing the uncertainties, several software are currently available for the ADCP users, such as OURSIN (Pierrefeu^[59]), QRev (Mueller^[42]) and QUant (Moore^[38]).

OURSIN can obtain influential parameters on the whole uncertainties with generating a file including the gauging results with uncertainty including the uncertainty sources. From moving-boat ADCP measurements obtained by most of ADCPs on the market, the discharge can be computed by QRev. Filtering and quality checking of the observed results can be automatically obtained and the potential quality issues during measurement by the users are feedbacked. The software provides statistics, characteristics of the measurement, and uncertainty assessments in order to assist users in properly rating the measurement. Monte Carlo simulations was implemented in QUant in order to obtain uncertainty of moving-boat ADCP discharge measurements. The contribution of error sources within the total estimated uncertainty can be determined from several data sets. The error sources were distinguished by the Type A and B among several factors, such as the proportion of unmeasured zones relative to measured zones, non-uniformity of targeted flow, operational commands and measurement cross section.

Bibliography

- [1] ISO 748, *Hydrometry — Measurement of liquid flow in open channels using current-meters or floats*
- [2] ISO 1070, *Hydrometry — Slope-area method*
- [3] ISO 5168, *Measurement of fluid flow — Procedures for the evaluation of uncertainties*
- [4] ISO/TS 24154,¹⁾ *Hydrometry — Measuring river velocity and discharge with acoustic Doppler profilers*
- [5] ISO/TS 25377, *Hydrometric uncertainty guidance (HUG)*
- [6] ARMSTRONG B., FULFORD J, THIBODEAUX K. (2015), *Quality assurance testing of acoustic Doppler current profiler transform matrices. Hydrologic Instrumentation Facility, U.S. Geological Survey, Stennis Space Center*
- [7] BICH W., COX M., MICHOTTE C.(2016), , Towards a new GUM — An update. *Metrologia*, **53** S149–159
- [8] BOLDT J.A., OBERG K.(2015), , Validation of streamflow measurements made with M9 and RiverRay acoustic Doppler current profilers. *Journal. of Hydraulic. Eng.*, 10.1061/(ASCE)HY.1943-7900.0001087
- [9] CHEN C.L. (1989), *Power law of flow resistance in open channels. Manning's formula revisited*. In: Proceedings of the International Conference on Channel Flow and Catchment Runoff. Centennial of Manning's Formula and Kuichling's Rational Formula, May 22–26, 1989, v. 8, p. 17–48
- [10] CHEN C.L.(1991). , Unified Theory on Power Laws for Flow Resistance. *ASCE Journal of Hydraulic Engineering*, **117**(3), March
- [11] Cohn, T.A., Kiang, J.E., Mason, R.R. (2013). Estimating discharge measurement uncertainty using the interpolated variance estimator. *Journal of Hydraulic Engineering*, 139(5),502–510
- [12] Dramais, G. (2011). *Quantification of uncertainty on ADCP discharge measurements*. Engineering diploma thesis, Conservatoire National des Arts et Métiers,
- [13] Environment Canada (2004). *Procedures for Conducting ADCP Discharge Measurements: Water Survey of Canada, Hydrometric Operations Division, SOP001-2004*
- [14] FULFORD J.M., SAUER V.B. (1986). Comparison of velocity interpolation methods for computing open-channel discharge. In: SUBITSKY S.Y. ed., *Selected papers in the hydrologic sciences: U.S. Geological Survey Water-Supply Paper 2290*, p. 139-44
- [15] GARCÍA C., TARRAB L., OBERG K.A., SZUPIANY R., CANTERO M.(2012). , Variance of discharge estimates sampled using acoustic Doppler current profilers from moving platforms. *Journal of hydraulic. Eng.*, **138**(8), 684–694
- [16] GARTNER J.W., GANJU N.K. (2002). *A preliminary evaluation of near-transducer velocities collected with low-blank acoustic Doppler current profiler*. In: Proceedings of Hydraulic Measurements and Experimental Methods. (WAHL T.L., PUGH C.A., OBERG K.A., VERMEYEN T.B., eds.). American Society of Civil Engineers
- [17] GONZALEZ-CASTRO J.A., ANSAR M., KELLMAN O. (2002). *Comparison of Discharge Estimates from ADCP Transect Data with Estimates from Fixed ADCP Mean Velocity Data*. In: Proceedings of the ASCE-IAHR Hydraulic Measurements & Experimental Methods Conference, Estes Park, CO (CD-ROM)

1) Withdrawn.

- [18] GONZALEZ-CASTRO J.A., BUZAD J., (2016). RiverFlowUA-a package to estimate total uncertainty in ADCP discharge measurement by FOTSE-with an application in hydrometry. River Flow 2016, Proceedings of the Eighth International Conference on Fluvial Hydraulics (St. Louis, MO, July 12–15, 2016), Eds. G. Constantinescu, M. Garcia and D. Hanes, Taylor and Francis Group, 715–723
- [19] GONZALEZ-CASTRO J.A., MUSTE M.(2007). , Framework for estimating uncertainty of ADCP measurements from a moving boat by standardized uncertainty analysis. *Journal. of Hydraulic Eng.*, **133**(12), 1390-1410
- [20] GONZALEZ-CASTRO J.A., MELCHING C.S., OBERG K.A. (1996). *Analysis of open-channel velocity measurements collected with an acoustic Doppler current profiler*. Proceedings from the first international conference on new/emerging concepts for rivers. Organised by the International Water Resources Association September 22–26
- [21] HUANG H.(2012). , Uncertainty model for in situ quality control of stationary ADCP open channel discharge measurement. *Journal. of Hydraulic. Eng.*, **138**(1), 4–12
- [22] HUANG H.(2014). , Uncertainty-based measurement quality control. *Accred Qual Assur*, **19** 65–73
- [23] HUANG H.(2015). , Statistical quality control of streamflow measurements with moving-boat acoustic Doppler current profilers. *Journal. of Hydraulic Research*, **53**(6), 820–827
- [24] HUANG H. (2016). *Estimation of Type A uncertainty of moving-boat ADCP streamflow measurements*. River Flow 2016, Proceedings of the Eighth International Conference on Fluvial Hydraulics (St. Louis, MO, July 12–15, 2016), Eds. G. Constantinescu, M. Garcia and D. Hanes, Taylor and Francis Group, 696–701
- [25] HUANG H.(2017). , Estimating random uncertainty of depth-averaged velocities measured by moving-boat acoustic Doppler current profilers. *Flow Measurement and Instrumentation*, **57**, 78–86. <https://doi.org/10.1016/j.flowmeasinst.2017.09.001>
- [26] HUANG H.(2018a). , Uncertainty estimation with a small number of measurements, Part I: new insights on the t-interval method and its limitations. *Meas. Sci. Technol.*, **29**(1), <https://doi.org/10.1088/1361-6501/aa96c7>
- [27] HUANG H.(2018b). , Uncertainty estimation with a small number of measurements, Part II: a redefinition of uncertainty and an estimator method. *Meas. Sci. Technol.*, **29**(1), <https://doi.org/10.1088/1361-6501/aa96d8>
- [28] HUANG H.(2018c). , A unified theory of measurement errors and uncertainties. *Measurement Science and Technology*, **29**(12), 125003 <https://doi.org/10.1088/1361-6501/aae50f>
- [29] HUANG H.(2018d). , A modified Simpson model for estimating random uncertainty of moving-boat ADCP streamflow measurements. *Flow Measurement and Instrumentation*, **61**, 84–93. <https://doi.org/10.1016/j.flowmeasinst.2018.03.002>
- [30] HUANG H.(2018e). , Estimating bias limit of moving-boat ADCP streamflow measurements. *Journal of Hydraulic Eng.*, **144**(6). [https://doi.org/10.1061/\(ASCE\)HY.1943-7900.0001465](https://doi.org/10.1061/(ASCE)HY.1943-7900.0001465)
- [31] HUANG H.(2018f). , Estimating uncertainty of streamflow measurements with moving-boat acoustic Doppler current profilers. *Hydrology Science Journal*, **63**(3), 353-368. <https://doi.org/10.1080/02626667.2018.1433833>
- [32] Joint Committee for Guides in Metrology (JCGM), (2008). Evaluation of measurement data - Guide to the expression of uncertainty in measurement (GUM 1995 with minor corrections). Sevres, France
- [33] Kim, D., Yu, K. (2010). Uncertainty estimation of the ADCP velocity measurements from the moving vessel method, (I) development of the framework. *KSCE J Civ Eng* 14, 797–801. <https://doi.org/10.1007/s12205-010-0950-6>

- [34] KANNO Y., YOROZUYA A., KITSUDA T. et al. (2011). , Proposal of ADCP measurement using an external compass, *Advances in River Engineering, JSCE*, Vol. **17**, pp.35–40, July
- [35] LE COZ J., BLANQUART B., POBANZ K. et al. (2016). , Estimating the uncertainty of stream gauging techniques using in situ collaborative interlaboratory experiments, *Journal of Hydraulic Eng.*, **142** (7), art. no. 04016011
- [36] Lee, K., Ho, H.-C., Muste M., and Wua, C.-H.(2014). Uncertainty in open channel discharge measurements acquired with StreamPro ADCP. *Journal of Hydrology*, 509, 101-114
- [37] MARSDEN R.F., INGRAM R.G.(2004). , Correcting for Beam Spread in Acoustic Doppler Current Profiler Measurements. *J. Atmos. Ocean. Technol.*, **21**, pp. 1491–1499
- [38] MOORE S.A., JAMIESON E.C., RAINVILLE F., RENNIE C.D., MUELLER D.S. (2016). Monte Carlo Approach for Uncertainty Analysis of Acoustic Doppler Current Profiler Discharge Measurement by Moving Boat. *Jounal. of Hydraulic. Eng.*, 143(3)
- [39] MOREY R. D., HOEKSTRA R., ROUDER J. N., LEE M. D., WAGENMAKERS E-J.(2016). , The fallacy of placing confidence in confidence intervals. *Psychon Bull Rev*, **23**(1), 103-123 <https://rd.springer.com/article/10.3758%2Fs13423-015-0947-8>
- [40] MORLOCK S.E. (1996). *Evaluation of Acoustic Doppler Current Profiler Measurements of River Discharge*. Water-Resources Investigations Report 95-701, U.S. Geological Survey
- [41] MUELLER D.S. (2002). *Field Assessment of Acoustic-Doppler Based Discharge Measurements*. In: Proceedings of the ASCE-IAHR Hydraulic Measurements & Experimental Methods Conference
- [42] MUELLER D.S., (2016). QRev: Software for computation and quality assurance of acoustic Doppler current profiler moving-boat streamflow measurements — Users manual, Version 2.8. U.S. Geological Survey Report Series 2016–1052
- [43] MUELLER D.S. (2016). *Consistent and efficient processing of ADCP streamflow measurements*. River Flow 2016, Proceedings of the Eighth International Conference on Fluvial Hydraulics (St. Louis, MO, July 12–15, 2016), Eds. G. Constantinescu, M. Garcia and D. Hanes, Taylor & Francis Group, 655–663
- [44] MUELLER D.S., WAGNER C.R.(2006). , Application of the Loop Method for Correcting Acoustic Doppler Current Profiler Discharge Measurements Biased by Sediment Transport. *U.S. Geological Survey, Scientific Investigations Report 2006–5079*
- [45] MUELLER D.S. (2005). *Computing Discharge in the Presence of a Moving Bed from a Moving Boat Without GNSS*, U.S. Geological Survey Office of Surface Water
- [46] MUELLER D.S., ABAD J.D., GARCIA C.M., GARTNER J.A., GARCIA M.H., OBERG K.A.(2007). , Errors in Acoustic Doppler Profiler Velocity Measurements Caused by Flow Disturbance. *Journal of Hydraulic Engineering*, **133**(12), pp. 1411–1420
- [47] MUELLER D.S., WAGNER C.R.(2007). , Correcting Acoustic Doppler Current Profiler Discharge Measurements Biased by Sediment Transport. *Journal of Hydraulic Eng.*, **133**(12), pp. 1329–1336
- [48] MUELLER D.S., WAGNER C.R., REHMEL M.S., OBERG K.A.,and RAINVILLE F. (2013). Measuring Discharge with Acoustic Doppler Current Profilers from a Moving Boat. U.S. Geological Survey, Techniques and Methods 3–A22 Version 2.0, December
- [49] MUSTE M., YU K., PRATT T., ABRAHAM D.(2004). , Practical Aspects of ADCP Data Use for Quantification of Mean River Flow Characteristics: Part II: Fixed-Vessel Measurements. *J. of Flow Meas. and Instr.*, **15** (1), pp. 17–28
- [50] MUSTE M., YU K., GONZALEZ-CASTRO J., STARZMANN E. (2004). Methodology for Estimating ADCP Measurement Uncertainty in Open-Channel Flows. In: *Proceedings World Water & Environmental Resources Congress 2004* (EWRI). Salt Lake City, UT

- [51] MUSTE M., STERN F., (2000). Proposed Uncertainty Assessment Methodology for Hydraulic and Water Resources Engineering. In: Proceedings of ASCE 2000 Joint Conference on Water Resources Engineering and Water Resources Planning & Management, Minneapolis, MN (CD-ROM)
- [52] MUSTE M. et al. , (2005). Standardized Uncertainty Analysis Framework for Acoustic Doppler Current Profilers Measurement. University of IOWA, South Florida Management District
- [53] Muste, M. (2009). Guidelines for the assessment of uncertainty of hydro-metric measurements. Commission for hydrology project: Assessment of the performance of flow measurement instruments and techniques. World Meteorological Organization—Weather, Climate and Water
- [54] NYSTROM E.A., OBERG K.A., REHMAN C.R.(2007). , Evaluation of mean velocity and turbulence measurements with ADCP's. *Journal of Hydraulic Eng.*, **133**(12), pp. 1310–1318
- [55] OBERG K.A., (2002). In search of easy-to-use methods for calibrating ADCPs for velocity and discharge methods. In: Wahl, T.L., Pugh, C.A., Oberg, K.A., and Vermeyen, T.B., eds., 2002, Hydraulic measurements and experimental methods 2002: Proceedings, Conference of Environmental and Water Resources Institute of the American Society of Civil Engineers, July 28–August 1, Estes Park, Colorado
- [56] OBERG K.A., MORLOCK S.E., CALDWELL W.S. (2005). *Quality-assurance plan for discharge measurements using acoustic Doppler current profilers*: U.S. Geological Survey Scientific Investigations Rep. **2005-5183**, 44 pp
- [57] OBERG K.A., MULLER D.S. (1994). *Recent Applications of Acoustic Doppler Current profilers*. Fundamentals and Advancements in Hydraulic Measurements and Experimentation, Hydraulics Division ASCE, pp. 341–350
- [58] OBERG K.A., MUELLER D.S.(2007). , Validation of Streamflow Measurements Made with Acoustic Doppler Current Profilers. *Journal of Hydraulic Engineering*, **133**(12), pp. 1421–1432
- [59] Pierrefeu, G., et al. (2017). OURSIN: Uncertainty distribution tool for moving-boat ADCP measurements. 2017 SHF Conf., Lyon (in French)
- [60] RAINVILLE F. (2005). *Application of Threshold Value to Moving Bed Test Results*. Environment Canada Water Survey Branch
- [61] SCHMIDT A.R., ESPEY W.H., (2004). Uncertainties in Discharges Measured by Acoustic Meters — A Case Study from Accounting for Illinois' Diversion of Water from Lake Michigan. In: Proceedings World Water & Environmental Resources Congress 2004 (EWRI), Salt Lake City, UT
- [62] SCHIELDS J.R., (personal communication) on ADCP measurements for validation of numerical simulations
- [63] SIMPSON M. (2002). *Discharge measurements using a Broad-band Acoustic Doppler Current Profiler*. U. S. Geological Survey Open File report., **Vol. 01-01**
- [64] TARRAB L., GARCÍA C.M., CANTERO M.I., OBERG K.(2012). , Role of turbulence fluctuations on uncertainties of acoustic Doppler current profiler discharge measurements. *Water Resources Research*, **48**(6), W06507, doi: 10.1029/2011WR011185
- [65] TRAFIMOW D., MARKS M.(2015). , Editorial. *Basic and Applied Social Psychology*, **37**(1), 1–2
- [66] U.S. GEOLOGICAL SURVEY (USGS), (2011). Exposure time for ADCP moving-boat discharge measurements made during steady flow conditions. Office of Surface Water Technical Memorandum, September 11
- [67] YORKE T.H., OBERG K.A.(2002). , Measuring River Discharge and Velocity with Acoustic Doppler Profilers. *J. of Flow Measurement and Instrumentation*, **13**, pp. 191–195
- [68] YOROZUYA A., OKADA S., KITSUTA T. et al. (2010). , Proposal of Tethered ADCP platform for High-speed Flow Measurement, *Advances in River Engineering, JSCE*, Vol. **16**, pp.59–64, June

- [69] SHIH H.H., PAYTON C., SPRENKE J., MERO T., (2000). Towing Speed Calibration of Acoustic Doppler Profiling Instruments. Joint Conference on Water Resource Engineering and Water Resources Planning and Management 2000. DOI: 10.1061/40517(2000)317
- [70] WHITE D. R.(2016). , In pursuit of a fit-for-purpose uncertainty guide. *Metrologia*, **53** S107–24

Bureau of Indian Standards

BIS is a statutory institution established under the *Bureau of Indian Standards Act, 2016* to promote harmonious development of the activities of standardization, marking and quality certification of goods and attending to connected matters in the country.

Copyright

BIS has the copyright of all its publications. No part of these publications may be reproduced in any form without the prior permission in writing of BIS. This does not preclude the free use, in the course of implementing the standard, of necessary details, such as symbols and sizes, type or grade designations. Enquiries relating to copyright be addressed to the Head (Publication & Sales), BIS.

Review of Indian Standards

Amendments are issued to standards as the need arises on the basis of comments. Standards are also reviewed periodically; a standard along with amendments is reaffirmed when such review indicates that no changes are needed; if the review indicates that changes are needed, it is taken up for revision. Users of Indian Standards should ascertain that they are in possession of the latest amendments or edition by referring to the website-www.bis.gov.in or www.standardsbis.in.

This Indian Standard has been developed from Doc No.: WRD 01 (23881).

Amendments Issued Since Publication

Amend No.	Date of Issue	Text Affected

BUREAU OF INDIAN STANDARDS

Headquarters:

Manak Bhavan, 9 Bahadur Shah Zafar Marg, New Delhi 110002

Telephones: 2323 0131, 2323 3375, 2323 9402

Website: www.bis.gov.in

Regional Offices:

Central : 601/A, Konnectus Tower -1, 6th Floor,
DMRC Building, Bhavbhuti Marg, New
Delhi 110002

Telephones

{ 2323 7617

Eastern : 8th Floor, Plot No 7/7 & 7/8, CP Block, Sector V,
Salt Lake, Kolkata, West Bengal 700091

{ 2367 0012
{ 2320 9474

Northern : Plot No. 4-A, Sector 27-B, Madhya Marg,
Chandigarh 160019

{ 265 9930

Southern : C.I.T. Campus, IV Cross Road, Taramani, Chennai 600113

{ 2254 1442
{ 2254 1216

Western : 5th Floor/MTNL CETTM, Technology Street, Hiranandani Gardens,
Powai, Mumbai 400076

{ 2570 0030
{ 2570 2715

Branches : AHMEDABAD, BENGALURU, BHOPAL, BHUBANESHWAR, CHANDIGARH, CHENNAI, COIMBATORE, DEHRADUN, DELHI, FARIDABAD, GHAZIABAD, GUWAHATI, HARYANA (CHANDIGARH), HUBLI, HYDERABAD, JAIPUR, JAMMU, JAMSHEDPUR, KOCHI, KOLKATA, LUCKNOW, MADURAI, MUMBAI, NAGPUR, NOIDA, PARWANOO, PATNA, PUNE, RAIPUR, RAJKOT, SURAT, VIJAYAWADA.