

---

---

वस्त्रादि — सूक्ष्म जीवों द्वारा आक्रमण  
प्रतिरोध के लिए पटसन वस्त्रों का परीक्षण  
( तीसरा पुनरीक्षण )

**Textiles — Testing of Jute Fabrics  
for Resistance to Attack by Micro-  
Organisms**  
( *Third Revision* )

ICS 59.060.10

© BIS 2024



भारतीय मानक ब्यूरो  
BUREAU OF INDIAN STANDARDS  
मानक भवन, 9 बहादुर शाह ज़फर मार्ग, नई दिल्ली - 110002  
MANAK BHAVAN, 9 BAHADUR SHAH ZAFAR MARG  
NEW DELHI - 110002  
[www.bis.gov.in](http://www.bis.gov.in) [www.standardsbis.in](http://www.standardsbis.in)

August 2024

Price Group 7

## FOREWORD

This Indian Standard (Third Revision) was adopted by the Bureau of Indian Standards, after the draft finalized by the Chemical Methods of Test Sectional Committee had been approved by the Textiles Division Council.

This standard was first published in 1960 and then first revised to modify the conditioning, sampling and testing clauses. However, during routine use of the Mixed Culture Method it has been felt later that the test procedure adopted does not permit quick growth of test fungi in the control fabrics so that one has to wait for 21 days to ensure effectiveness of the test. Hence a change with respect to this test procedure of fungal growth in the mixed culture method has become warranted so as to get uniform and luxuriant growth of test fungi in all the control specimens within a shorter period of time (10 days). Of the test fungi used in the mixed culture method, alterations have been made in respect of three fungal strains *Curvularia lunata* IJIRA 10, *Penicillium rubrum* IJIRA 27 and *Penicillium wortmanni* IJIRA 130.64 have been replaced by *Curvularia lunata* IJIRA 10.1, *Penicillium rubrum* IJIRA 127.1 and *penicillium wortmanni* 130.63 respectively. These changes have been made to improve the efficacy of the test. The method for the preparation of mixed spore suspension ([Annex C](#)) has also been changed with a view to making it less time consuming, simple and at the same time effective. [Annex D](#) which describes vapour sterilization of fabrics prior to testing by the mixed culture method has been incorporated afresh.

Jute fabrics are liable to deterioration by the action of micro-organisms. Since they are often stored, transported and used under conditions favourable for the growth of micro-organism, various preservative treatments have been developed and their number is constantly increasing.

Two methods for testing jute fabrics for resistance to attack by micro-organisms have been prescribed in this standard, namely, mixed cultured method and soil burial method. In the first method, a mixture of spores of five different fungi which are frequently the cause of deterioration of jute fabrics, is used. In the second method, the fabric is subjected to the action of a much greater variety of micro-organisms, both fungi and bacteria, normally found in the soil.

The mixed culture method prescribed in this standard serves to assess the behaviour of jute fabrics under exposure to humid warm atmosphere whereas the soil burial method serves to assess their behaviour under conditions of contact or contamination with soil. Since, often a combination of the above two conditions exists in practice in relation to the use of the fabrics, both the methods are to be used.

The standard was based on the extensive research carried out by the Indian Jute Industries Research Association (IJIRA). To facilitate supply, the culture members as set out below may also be mentioned.

| SI No.<br>(1) | Micro-organisms<br>(2)                  | Culture No.<br>(3) |
|---------------|---|--------------------|
| i)            | <i>Chaetomium indicum</i>               | 75                 |
| ii)           | <i>Curvularia lunata</i>                | 10.1               |
| iii)          | <i>Aspergillus fumigatus</i> (see Note) | 14                 |
| iv)           | <i>Penicillium rubrum</i>               | 127.1              |
| v)            | <i>Penicillium wortmanni</i>            | 130.63             |

NOTE — *Aspergillus fumigatus* has been found to cause infection of lungs and of external ear in human beings. Great care should, therefore, be taken in handling the organisms not to inhale the spore dust from the culture tube when preparing the mixed spore suspension (see [Annex B](#)).

The methods prescribed in this standard can also be used evaluating preservatives or treatments designed to protect jute fabrics from damage by micro-organisms. In such cases, the preservative or the treatment has to be applied to a uniformly good quality jute fabric by the procedure recommended by the supplier or the originator and the treated fabric then tested.

(Continued on third cover)

*Indian Standard***TEXTILES — TESTING OF JUTE FABRICS FOR RESISTANCE TO ATTACK BY MICRO-ORGANISMS***( Third Revision )***1 SCOPE**

This standard prescribes two methods, namely, mixed culture method and the soil burial method for evaluating jute fabrics for resistance to attack by micro-organisms.

**2 REFERENCES**

The standards given below contain provisions which, through reference in this text, constitute provisions of this standard. At the time of publication, the editions indicated were valid. All standards are subject to revision, and parties to agreements based on this standard are encouraged to investigate the possibility of applying the most recent edition of these standards:

| <i>IS No.</i>                               | <i>Title</i>  |
|---|---|
| IS 460 (Part 1) : 2020                      | Test sieves — Specification: Part 1 Wire cloth test sieves ( <i>fourth revision</i> )   |
| IS 6359 : 2023                              | Method for conditioning of textiles ( <i>first revision</i> )   |
| IS 1969 (Part 1) : 2018/ ISO 13934-1 : 2013 | Textiles — Tensile properties of fabrics: Part 1 Determination of maximum force and elongation at maximum force using the strip method ( <i>fourth revision</i> ) |

**3 ATMOSPHERIC CONDITIONS FOR CONDITIONING AND TESTING**

**3.1** The tests shall be carried out under the conditions laid down in the respective test procedures. However, the specimens for breaking load testing shall be conditioned to moisture equilibrium and tested in the standard atmosphere at 65 percent  $\pm$  2 percent relative humidity and 27 °C  $\pm$  2 °C temperature (*see* IS 6359).

**3.2** When the specimens have been left in such an atmosphere for 24 h in such a way as to expose, as far as possible, all portions of the specimens to the standard atmosphere, they shall be deemed to have reached moisture equilibrium.

**4 SAMPLING****4.1 Lot**

The quantity of one definite type of jute fabric delivered to a buyer against one despatch note shall constitute a lot.

**4.2** Samples shall be drawn so as to be representative of the lot. Samples drawn in accordance with the procedures laid down in material specification or as agreed to between the buyer and the seller shall be taken as representative of the lot.

**4.3** Take a sufficiently long piece (*see* Note under [4.7](#)) from each sample selected. Cut it into two pieces of unequal lengths, one of the pieces being nearly half the length of the other. Mark the smaller piece to identify it as the test piece, set aside the other piece for leaching (*see* [4.6](#)).

**4.4** From the basic fabric, cut a piece of length equal to the length of the test piece and mark it to identify it as the control piece (*see* Note under [4.7](#)).

**4.5** From the test pieces (*see* [4.3](#)), cut at random a set of 18 specimens, each of size 25 cm  $\times$  4 cm, with their longer sides parallel to warp threads. Mark the specimens so that they can be identified as test specimens constituting the best sample.

**4.6** From the unmarked pieces (*see* [4.3](#)), cut at random test pieces of suitable length with their longer sides parallel to warp threads such that they can be accommodated in the leaching chamber (*see* [Annex A](#)). Leach the test pieces one by one according to the method prescribed in [Annex B](#) and dry them in air. Cut each of the leached pieces at random to obtain a set of 18 leached specimens, each of size 25 cm  $\times$  4 cm. Mark the specimens so that they can be identified as leached test specimens constituting the leached test sample.

**4.7** From the control piece (*see* [4.4](#)), cut at random a set of 18 specimens, each of size 25 cm  $\times$  4 cm, with their longer sides parallel to warp threads. Mark the specimens so that they can be identified as control specimens constituting the control sample.

To access Indian Standards click on the link below:

[https://www.services.bis.gov.in/php/BIS\\_2.0/bisconnect/knowyourstandards/Indian\\_standards/isdetails/](https://www.services.bis.gov.in/php/BIS_2.0/bisconnect/knowyourstandards/Indian_standards/isdetails/)

NOTE — The total length of the pieces will depend on the width of the fabric, but it should be such that one-third of the length is sufficient to give 18 specimens according to 4.5. If an authentic sample of the basic fabric is not available, a fabric similar in construction to the one under test and free from size and finish should be used.

4.8 Ravel down to 14 threads all the specimens in the test sample (see 4.5), leached test sample (see 4.6) and control sample (see 4.7), trimming off the weft threads.

## 5 MIXED CULTURE METHOD

### 5.1 Apparatus

5.1.1 *Small Petri Dishes* — each 10 cm in diameter and provided with a lid

5.1.2 *Large Petri Dishes* — each 15 cm in diameter and 3 cm high, provided with a lid

5.1.3 *Pipettes* — 1 ml

5.1.4 *Steriliser*

5.1.5 *Incubator*

### 5.2 Test Organisms

Cultures of the following test organisms:

- a) *Chaetamium indicum*;
- b) *Curvularia lunata*;
- c) *Aspergillus fumigatus*;
- d) *Penicillium rubrum*; and
- e) *Penicillium wortmanni*.

### 5.3 Procedure

5.3.1 Draw at random 6 test specimens (see 4.8). Condition them to moisture equilibrium in the standard atmosphere (see 3) and determine the breaking load of each specimen by the method prescribed in IS 1969 (Part 1). Find the average of all the values.

5.3.2 From the leached test sample (see 4.8), draw at random 6 specimens. Condition them to moisture equilibrium in the standard atmosphere (see 3) and determine the breaking load of each specimen by the method prescribed in IS 1969. Find the average of all the values.

5.3.3 Draw at random 6 control specimens (see 4.8). Condition them to moisture equilibrium in the standard atmosphere (see 3) and determine the breaking load of each specimen by the method prescribed in IS 1969 (Part 1). Find the average of all the values.

5.3.4 Prepare in the manner prescribed in Annex B:

- a) Czapek dox salt agar medium; and
- b) a mixed suspension of the spores of the test organisms prescribed in 5.2.

5.3.5 Draw from the test sample (see 4.8) six test specimens.

5.3.6 Melt sterilized czapek dox salt agar medium (20 ml) and pour in each sterilized small petri dish and allow the agar medium to set firmly. Leave the plates overnight to dry up the excess moisture on the surface of the agar medium. Remove the lid of the petri dish and place two sterilized specimens (see Annex C and Annex D) on the agar plate side by side such that the central portion (about 4 cm) of each specimen touches lightly the agar surface and the two edges of each hang outside the petri dish. Inoculate the specimen by spreading 1.5 ml of the mixed spore suspension on the central portion of each specimen (see Fig. 1 and Fig. 2).

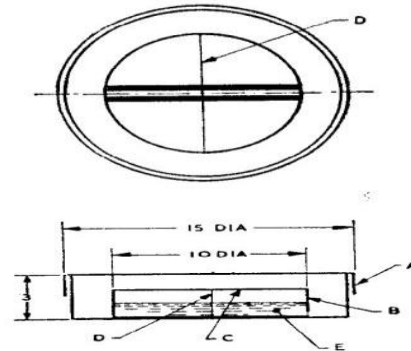

Key

- A - large petri dish
- B - small petri dish
- D - supporting thread
- C - specimen

All dimensions in millimetres.

FIG. 1 PETRI DISH ASSEMBLY

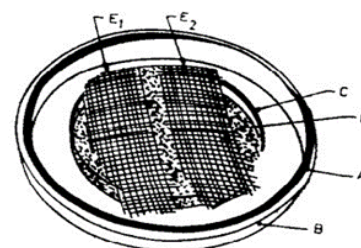

Key

- A - lid of the big petri dish
- B - big petri dish
- C - small petri dish without lid
- D - mineral salt agar layer
- E<sub>1</sub> and E<sub>2</sub> - jute fabric samples

FIG. 2 SCHEMATIC REPRESENTATION OF THE TESTING SYSTEM FOR EVALUATION OF THE RESISTANCE OF JUTE SAMPLES TO ATTACK BY FUNGI

**5.3.6.1** Fold carefully the free edges of the specimen down the outer lower side of the agar plate and carefully place the agar plate inside a sterilized large Petri dish and cover it with a lid. Finally put all the Petri dish assemblies in an incubator at  $30\text{ }^{\circ}\text{C} \pm 2\text{ }^{\circ}\text{C}$  and 100 percent relative humidity. The control specimens are incubated for 10 days, whereas test specimens leached and unleached are incubated for 21 days. After incubation is complete, remove the specimens, wash them gently to free them from agar and dry them in air (*see Note*). Condition each specimen to moisture equilibrium in the standard atmosphere and determine the breaking load of each specimen by the method prescribed in IS 1969 (Part 1). Find the average of all the values.

NOTE — Exposure of test specimens after washing to methyl alcohol fumes in a desiccator for 2 h to 4 h before drying is desirable.

**5.3.7** Draw 6 specimens from the leached test sample (*see 4.8*) and test them in the manner prescribed in [5.3.6](#).

**5.3.8** Draw 6 control specimens from the control sample (*see 4.8*) and test them in the manner prescribed in [5.3.6](#). If the control specimens are not covered with profuse visible growth of micro-organisms, the test shall be repeated.

**5.3.9** Calculate the loss in breaking load, percent of the basic fabric on incubation (*L*) by the following formula:

$$L = \frac{100(a-b)}{a}$$

where

*a* = average breaking load value obtained as in [5.3.3](#); and

*b* = average breaking load value obtained as in [5.3.8](#).

If the value of *L* is less than 70 percent, the test shall be repeated.

**5.3.10** Calculate in the manner prescribed in [5.3.9](#); the loss in breaking load percent of the fabric under test on incubation prior to leaching, equating to:

'*a*' the value obtained as in [5.3.1](#), and '*b*' the value obtained as in [5.3.6](#).

NOTE — The fabric should be considered satisfactorily resistant to attack by micro-organisms if the value of *L* does not exceed 20 percent.

**5.3.11** Calculate in the manner prescribed in [5.3.9](#) the loss in breaking load, percent, of the fabric under test on incubation after leaching, equating to:

'*a*' the value obtained as in [5.3.2](#), and '*b*' the value obtained as in [5.3.7](#).

NOTE — The fabric should be considered satisfactorily resistant to attack by micro-organisms if the value of *L* does not exceed 20 percent.

## 6 SOIL BURIAL METHOD

### 6.1 Apparatus

**6.1.1** *Glass Jars* — round, wide-mouthed, flat-bottomed

**6.1.2** *Petri Dishes* — as covers

**6.1.3** *Incubator* — capable of being maintained at  $30\text{ }^{\circ}\text{C} \pm 2\text{ }^{\circ}\text{C}$  and provided with trays full of water at the bottom.

**6.1.4** *Cylinder*

### 6.2 Test Soil

Prepared as prescribed in [Annex C](#).

### 6.3 Procedure

**6.3.1** Take the remaining 6 test specimens (*see 4.8*).

**6.3.2** Spread the test soil on each specimen in a thin layer and roll it lightly into the form of a cylinder. Place each specimen separately in a glass jar of suitable size containing a thin layer of soil at the bottom and pour soil in the jar to cover the sides and top of the specimen, thus bringing both sides of the specimen in contact with the soil. The soil inside the jars should cover about three-fourth of their height and the specimens should be about 5 cm to 6 cm below the soil surface. Cover the jars with petri dishes and keep them in the incubator at  $30\text{ }^{\circ}\text{C} \pm 2\text{ }^{\circ}\text{C}$ . Incubate the specimens for 21 days. After 21 days of incubation, check the moisture of the soil and if need be, adjust the moisture to 25 percent to 27 percent. Remove the specimens, wash them gently to free them from soil, and dry them in air (*see Note*). Condition the specimens to moisture equilibrium in the standard atmosphere and determine the breaking load of each specimen by the method prescribed in IS 1969 (Part 1). Find the average of all the values.

NOTE — Exposure of the test specimen after washing to methyl alcohol fumes in a desiccator for 2 h to 4 h before drying gives better results.

**6.3.3** Take the remaining 6 leached test specimens (*see 4.8*) and test them in the manner prescribed in [6.3.2](#).

**6.3.4** Take the remaining 6 control test specimens (*see 4.8*) and test them in the manner prescribed in [6.3.2](#).

**6.3.5** Calculate the loss in breaking load, percent, of the basic fabric on soil burial (L) by the following formula:

$$L = \frac{100 (a - b)}{a}$$

where

*a* = average breaking load value obtained as in [5.3.3](#); and

*b* = average breaking load value obtained as in [6.3.4](#).

If the value of L is less than 80 percent, the test shall be repeated.

**6.3.6** Calculate in the manner prescribed in [6.3.5](#) the loss in breaking load, percent, of the fabric under test on soil burial prior to leaching, equating to:

'*a*' the value obtained as in [5.3.1](#), and '*b*' the value obtained as in [6.3.2](#).

NOTE — The fabric should be considered satisfactorily resistant to attack by micro-organisms if the value of L does not exceed 20 percent.

**6.3.7** Calculate in the manner prescribed in [6.3.5](#) the loss in breaking load, percent, of the fabric under test on soil burial after leaching, equating to:

'*a*' the value obtained as in [5.3.2](#), and '*b*' the value obtained as in [6.3.3](#).

NOTE — The fabric should be considered satisfactorily resistant to attack by micro-organisms if the value of L does not exceed 20 percent.

## 7 REPORT

**7.1** The report shall include the following information:

- a) Mixed culture method
  - 1) Type of fabric under test;
  - 2) Loss in breaking load, percent of the basic fabric on incubation (*see* [5.3.9](#));
  - 3) Loss in breaking load, percent of the fabric under test on incubation prior to leaching (*see* [5.3.10](#)); and
  - 4) Loss in breaking load, percent of the fabric under test on incubation after leaching (*see* [5.3.11](#)).
- b) Soil burial method
  - 1) Type of fabric under test;
  - 2) Loss in breaking load, percent of the basic fabric on soil burial (*see* [6.3.5](#));
  - 3) Loss in breaking load, percent of the fabric under test on soil burial prior to leaching (*see* [6.3.6](#)); and
  - 4) Loss in breaking load, percent of the fabric under test on soil burial after leaching (*see* [6.3.7](#)).

## ANNEX A

(Clause 4.6)

## METHOD OF LEACHING

## A-1 APPARATUS

**A-1.1 Leaching Apparatus** (see Fig. 3) — consisting of a rectangular galvanized iron vessel of convenient size (see Note), provided with a copper bottom with perforations 0.4 mm in diameter and 20 mm apart and an automatic device to maintain the level of water in it at a height of 50 mm the vessel being so fixed that its bottom is 300 mm above the horizontal glass base of the apparatus. Which is of the same size as the perforated bottom of the vessel.

NOTE — The size of the vessel should be such as to enable the whole leaching operation to be completed within a reasonable period of time, the fabric being cut into pieces of suitable size (multiples of test pieces) which should then be leached one by one.

## A-2 PROCEDURE

**A-2.1** Place a piece of the fabric under test on the horizontal glass base. Feed tap water (pH 6.5 to 7.5 at  $30\text{ }^{\circ}\text{C} \pm 2\text{ }^{\circ}\text{C}$ ) continuously for 4 h into the vessel of the apparatus and let it fall in a shower on the specimen. Turn over the specimen after 2 h and remove it at the end of 4 h.

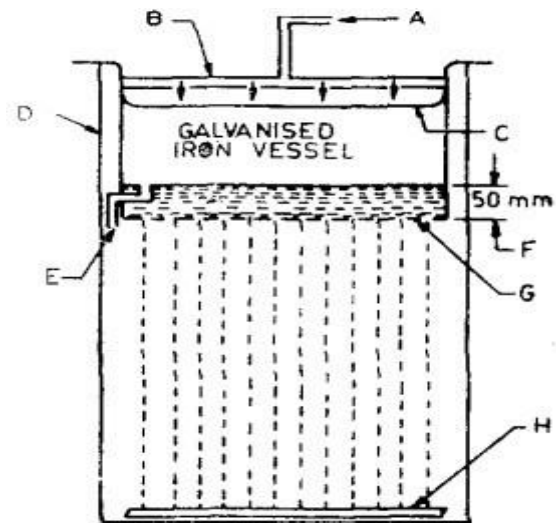

Key

- A - water inlet
- B - supply tube with evenly
- C - baffle sheet
- D - wooden stand
- E - constant level outlet
- F - level of water distributed holes
- G - perforated bottom of vessel
- H - glass base (27 cm × 55 cm) for amples

FIG. 3 LEACHING APPARATUS



**ANNEX B** 

(Clauses [4.6](#) and [5.3.4](#))

### B-1 PREPARATION OF CZAPEK DOX SALT AGAR MEDIUM

Dissolve the following salts in quantities indicated per 100 ml of distilled water.

a) *Solution A*

- |   |       |
|---|-------|
| i) Sodium nitrate (NaNO <sub>3</sub> )                        | 0.8 g |
| ii) Magnesium sulphate (MgSO <sub>4</sub> .7H <sub>2</sub> O) | 0.2 g |
| iii) Potassium chloride (KCl)                                 | 0.2 g |

b) *Solution B*

- |  |       |
|--|-------|
| i) Potassium dihydrogen phosphate (KH <sub>2</sub> PO <sub>4</sub> ) | 0.1 g |
| ii) Dipotassium hydrogen phosphate                                   | 0.3 g |

During preparation of the medium, mix Solution A and Solution B in the proportion 1 : 1. Add equal volume of distilled water. Finally add agar (2 percent *m/v*). Heat on a water bath to dissolve agar and dispense in culture tubes in 20 ml quantities each. Plug the culture tubes with non-absorbent cotton and sterilize the medium in an autoclave at 103.35 kPa (15 psi) for 15 min.

### B-2 PREPARATION OF MIX SPORE SUSPENSION

#### B-2.1 Media and Salt Solution

##### B-2.1.1 Czapek Dox Agar Slants

Prepare czapek dox agar medium as described in C-1. Dispense 7 ml of this medium in culture tubes, plug and sterilize at 103.35 kPa (15 psi) for 15 min. In a separate culture tube, sterilize several filter paper strips (1 cm × 6 cm) in a similar way. Following sterilization, place the culture tubes containing hot, molten medium in a slanting position until the agar solidifies. Next introduce filter paper strips on the surface of agar slants aseptically, one filter paper per agar slant.

##### B-2.1.2 Malt Extract-Peptone Agar Slants

Dissolve 2.5 g of malt extract and 0.1 g of peptone in 100 ml distilled water. Adjust pH to 6.0. Add agar (2 percent *m/v*) and dissolve it by heating over a water bath. Dispense in culture tubes (7 ml quantities per tube), plug with non-absorbent cotton and sterilize at 103.35 kPa (15 psi) for 15 min. Following this, prepare malt agar slants by keeping the culture tubes containing hot, molten malt agar in a slanting position until the agar solidifies.

**B-2.1.3** Quadruple strength czapek dox salt solution with 0.01 percent triton. Dissolve the following salts in quantities indicated per 100 ml of distilled water.

a) *Solution A*

- |  |       |
|--|-------|
| 1) Sodium nitrate (NaNO <sub>3</sub> )                       | 1.6 g |
| 2) Magnesium sulphate (MgSO <sub>4</sub> .7H <sub>2</sub> O) | 0.4 g |
| 3) Potassium chloride (KCl)                                  | 0.4 g |

b) *Solution B*

- |  |       |
|--|-------|
| 1) Potassium dihydrogen phosphate (KH <sub>2</sub> PO <sub>4</sub> ) | 0.2 g |
| 2) Dipotassium hydrogen phosphate (K <sub>2</sub> HPO <sub>4</sub> ) | 0.6 g |

Sterilize each solution separately. After autoclaving at 103.35 kPa (15 psi) for 15 min, mix the two solutions when cold and add sterilized triton water so that the final concentration of triton in the solution becomes 0.01 percent (*v/v*).

#### B-2.2 Maintenance of Cultures

**B-2.2.1** The following fungal strains shall be preserved in czapek dox filter paper agar slants:

- a) *Chaetomium indicum*;
- b) *Curvularialunata*;
- c) *Aspergillus fumigatus*; and
- d) *Penicillium rubrum*.

**B-2.2.2** *Penicillium wortmanni*, however, shall be preserved malt extract peptone agar-slants.

#### B-2.3 Sub-Cultures

Inoculate malt extract-peptone agar slants separately with well sporulated cultures of the above mentioned five organisms. Incubate the tubes at 30 °C ± 2 °C for 7 to 10 days until mature growth of the organisms is obtained. Equal number of sub-cultures shall be made for each fungal culture.

#### B-2.4 Preparation of Mixed Spore Suspension

Take equal number of malt agar slant cultures of each of the 5 micro-organisms mentioned above. Add 5 ml quadruple strength czapek dox salt solution supplemented with 0.01 percent triton to each culture tube. Lightly scratch the surface of growth aseptically by a sterilized glass rod and rotate the culture tubes between the palms until the spore suspension in the tube is moderately dense. Filter the spore suspension through a piece of sterile muslin or cotton-wool in a sterilized Erlenmeyer flask. In a similar way, pool spore suspensions from all the slant cultures in the same Erlenmeyer flask. Mix the spores well by placing the flask on a cyclomixer.



**ANNEX C**(Clauses [5.3.6](#) and [6.2](#))**PREPARATION OF TEST SOIL**

**C-1** Prepare a compost by mixing thoroughly fertile garden soil, cow dung manure and sand in the proportion of 2 : 1: 1. Pass it through 355 µm IS sieve [see IS 460 (Part 1)]. Adjust its moisture content to 25 percent to 27 percent and test it in the manner prescribed in [C-1.1](#) to [C-1.5](#).

**C-1.1** Take a sufficiently long piece of hessian of the following construction and draw from it 12 pieces, each of size 25 cm × 4 cm:

- a) Ends/cm        4
- b) Picks/cm      4
- c) Mass, g/m<sup>2</sup>   270

**C-1.2** Take 6 pieces of the hessian, condition them to moisture equilibrium in the standard atmosphere

(see [3](#)) and determine the breaking load of each by the method prescribed in IS 1969 (Part 1). Find the average of all the values.

**C-1.3** Test the remaining 6 pieces of the hessian in the manner prescribed in [6.3.2](#), incubating the pieces for 7 days only. Record the average value for breaking load.

**C-1.4** Calculate the loss in breaking load, percent, of the cloth after soil burial.

**C-1.5** The soil shall be deemed to be able for the test if the loss in breaking load of the cloth, so determined, is 80 percent or more.

**ANNEX D**(Clause [5.3.6](#))**STERILIZATION OF JUTE SPECIMENS IN METHYL ALCOHOL VAPOUR****D-1 PROCEDURE**

Pack the specimens loosely in a desiccator of suitable size containing methyl alcohol and keep them for 24 h (or longer) at room temperature. In the meantime, make another desiccator ready by sterilizing it with methyl alcohol vapour for a period of 12 h at room temperature. Transfer the specimens from the first desiccator to the second desiccator

with a pair of sterile tongs in a sterile chamber/ environment. Connect the second desiccator to a vacuum pump through a cotton wool filter and exhaust the desiccator at room temperature for 6 h to remove traces of methyl alcohol. Bring the pressure in the desiccator to the atmospheric pressure by slowly letting in air through the cotton-wool filter.

## ANNEX E

*(Foreword)*

## COMMITTEE COMPOSITION

Chemical Methods of Test Sectional Committee, TXD 05

| <i>Organization</i>  | <i>Representative</i>   |
|--|---|
| The Synthetics & Art Silk Mills Research Association, Mumbai     | DR MANISHA MATHUR ( <i>Chairperson</i> )                                    |
| Agilent Technology India Pvt Ltd, New Delhi                      | SHRI PRAVEEN ARYA<br>DR MANOJ SURWADE ( <i>Alternate</i> )                  |
| Ahmedabad Textile Industry's Research Association, Ahmedabad     | SHRIMATI DEEPALI PLAWAT<br>SHRIMATI FAHIMUNNISA KHATIB ( <i>Alternate</i> ) |
| Bidhata Industries Pvt Ltd, Mumbai                               | SHRI ROHIT PACHERIWALA<br>SHRI R. K. PACHERIWALA ( <i>Alternate</i> )       |
| Central Coir Research Institute, Kochi                           | DIRECTOR, RDTE<br>SENIOR SCIENTIFIC OFFICER (POLYMER) ( <i>Alternate</i> )  |
| Central Institute for Research on Cotton Technology, Mumbai      | DR SUJATA SAXENA<br>DR A. S. M. RAJA ( <i>Alternate</i> )                   |
| Central Silk Technological Research Institute (CSTRI), Bengaluru | DR NIVEDITA S.<br>SHRIMATI BROJESHWARI DAS ( <i>Alternate</i> )             |
| Directorate General of Quality Assurance (CQAT & C), Kanpur      | COL D. B. KUSHWAHA<br>SHRI PURUSHOTTAM DE ( <i>Alternate</i> )              |
| EMC Testing & Compliance LLP, Gurugram                           | SHRI VIVEK SHARMA<br>SHRI SATYA RANJAN BISWAL ( <i>Alternate</i> )          |
| Global Organic Textile Standard, Thane                           | SHRI RAHUL BHAJEKAR<br>SHRIMATI PRACHI GUPTA ( <i>Alternate</i> )           |
| Indian Jute Industries Research Association, Kolkata             | MS ISHPITA ROY  |
| Manjushree Spntek Pvt Ltd, Bengaluru                             | SHRI MADHAN R.  |
| Northern India Textiles Research Association, Ghaziabad          | DR M. S. PARMAR   |
| Office of the Textile Commissioner, Mumbai                       | SHRI GAURAV GUPTA<br>SHRI RAJESH MAHAJAN ( <i>Alternate</i> )               |
| Raymonds Ltd, Mumbai   | SHRI PRABHAT PARASHER<br>SHRI SAURAV SHEKHAR ( <i>Alternate</i> )           |
| Reliance Industries Ltd, New Delhi                               | SHRI M. S. VERMA<br>SHRI MAHESH C. SHARMA ( <i>Alternate</i> )              |
| SGS, Mumbai  | DR KARTHIKEYAN K.<br>SHRIMATI MAHALAKSHMI R. ( <i>Alternate</i> )           |
| Sunil Industries, Mumbai   | SHRI PRADEEP ROONGTA<br>SHRI RAMESH KHANNA ( <i>Alternate</i> )             |

| <i>Organization</i>   | <i>Representative</i>  |
|---|--|
| Testex India Laboratories Pvt Ltd, Mumbai   | SHRIMATI MEETA SHINGALA<br>SHRI MAHESH SHARMA ( <i>Alternate</i> )   |
| Texanlab Laboratoires Pvt Ltd, Navi Mumbai  | SHRI MILIND R. MARATHE<br>SHRI VIVEK PATIL ( <i>Alternate</i> )  |
| Textile Committee, Mumbai   | SHRI KARTIKEYAN DHANDA<br>DR P. RAVICHANDRAN ( <i>Alternate</i> )  |
| The Bombay Textile Research Association, Mumbai   | SHRI M. P. SATYANARAYAN<br>SHRIMATI SAROJ VAIRAGI ( <i>Alternate</i> )   |
| The South India Textile Research Association,<br>Coimbatore   | DR PRAKASH VASUDEVAN<br>SHRI S. SIVAKUMAR ( <i>Alternate</i> )   |
| The Synthetics & Art Silk Mills Research<br>Association, Mumbai  | SHRIMATI ASHWINI A. SUDAM<br>SHRIMATI LEENA MHATRE ( <i>Alternate</i> )  |
| <b>U P Textile Technology Institute</b>   | DR ARUN KUMAR PATRA<br>DR SUBHANKAR MAITY ( <i>Alternate</i> )   |
| Wool Research Association, Thane  | DR MIRNAL CHOUDHARI<br>DR SWATI MAHADIK ( <i>Alternate</i> )   |
| BIS Directorate General   | SHRI J. K. GUPTA, SCIENTIST 'E'/DIRECTOR AND HEAD<br>(TEXTILES) [REPRESENTING DIRECTOR GENERAL<br>( <i>Ex-officio</i> )] |

*Member Secretary*  
SHRI DHARMBEER  
SCIENTIST 'D'/JOINT DIRECTOR  
(TEXTILES), BIS



*(Continued from second cover)*

This revision has been made in the light of experience gained since its last revision and to incorporate the following changes:

- a) Apparatus and reagents have been updated; and
- b) References to the Indian standard have been updated.

The composition of the Committee responsible for the formulation of this standard is given in [Annex E](#).

In reporting the result of a test or analysis made in accordance with this standard, if the final value, observed or calculated, expressing the result of a test or analysis, shall be rounded off in accordance with IS 2 : 2022 'Rules for rounding off numerical values (*second revision*)'.

## Bureau of Indian Standards

BIS is a statutory institution established under the *Bureau of Indian Standards Act, 2016* to promote harmonious development of the activities of standardization, marking and quality certification of goods and attending to connected matters in the country.

### Copyright

BIS has the copyright of all its publications. No part of these publications may be reproduced in any form without the prior permission in writing of BIS. This does not preclude the free use, in the course of implementing the standard, of necessary details, such as symbols and sizes, type or grade designations. Enquiries relating to copyright be addressed to the Head (Publication & Sales), BIS.

### Review of Indian Standards

Amendments are issued to standards as the need arises on the basis of comments. Standards are also reviewed periodically; a standard along with amendments is reaffirmed when such review indicates that no changes are needed; if the review indicates that changes are needed, it is taken up for revision. Users of Indian Standards should ascertain that they are in possession of the latest amendments or edition by referring to the website-[www.bis.gov.in](http://www.bis.gov.in) or [www.standardsbis.in](http://www.standardsbis.in).

This Indian Standard has been developed from Doc No.: TXD 05 (23597).

### Amendments Issued Since Publication

| Amend No. | Date of Issue | Text Affected |
|-----------|---------------|---------------|
|           |               |               |
|           |               |               |
|           |               |               |
|           |               |               |

## BUREAU OF INDIAN STANDARDS

### Headquarters:

Manak Bhavan, 9 Bahadur Shah Zafar Marg, New Delhi 110002

Telephones: 2323 0131, 2323 3375, 2323 9402

Website: [www.bis.gov.in](http://www.bis.gov.in)

### Regional Offices:

|   | Telephones               |
|---|--------------------------|
| Central : 601/A, Konnectus Tower -1, 6 <sup>th</sup> Floor,<br>DMRC Building, Bhavbhuti Marg, New<br>Delhi 110002     | { 2323 7617              |
| Eastern : 8 <sup>th</sup> Floor, Plot No 7/7 & 7/8, CP Block, Sector V,<br>Salt Lake, Kolkata, West Bengal 700091     | { 2367 0012<br>2320 9474 |
| Northern : Plot No. 4-A, Sector 27-B, Madhya Marg,<br>Chandigarh 160019   | { 265 9930               |
| Southern : C.I.T. Campus, IV Cross Road, Taramani, Chennai 600113   | { 2254 1442<br>2254 1216 |
| Western : Manakalya, 5 <sup>th</sup> Floor/MTNL CETTM, Technology Street, Hiranandani Gardens, Powai<br>Mumbai 400076 | { 25700030<br>25702715   |

**Branches :** AHMEDABAD, BENGALURU, BHOPAL, BHUBANESHWAR, CHANDIGARH, CHENNAI, COIMBATORE, DEHRADUN, DELHI, FARIDABAD, GHAZIABAD, GUWAHATI, HARYANA (CHANDIGARH), HUBLI, HYDERABAD, JAIPUR, JAMMU, JAMSHEDPUR, KOCHI, KOLKATA, LUCKNOW, MADURAI, MUMBAI, NAGPUR, NOIDA, PARWANOO, PATNA, PUNE, RAIPUR, RAJKOT, SURAT, VIJAYAWADA.