

औद्योगिक ट्रैक्टरों और संचालित
औद्योगिक ट्रकों के यात्रा की दिशा
नियंत्रण — विशिष्टि
(ISO 5053 : 1987, संशोधित)

(पहला पुनरीक्षण)

Direction of Travel-Controls for
Industrial Tractors and Powered
Industrial Trucks — Specification
(ISO 5053 : 1987, MOD)

(First Revision)

ICS 53.060

© BIS 2024



भारतीय मानक ब्यूरो
BUREAU OF INDIAN STANDARDS
मानक भवन, 9 बहादुर शाह ज़फर मार्ग, नई दिल्ली - 110002
MANAK BHAVAN, 9 BAHADUR SHAH ZAFAR MARG
NEW DELHI - 110002

www.bis.gov.in www.standardsbis.in

FOREWORD

This Indian Standard was adopted by the Bureau of Indian Standards, after the draft finalized by the Transport Tractors, Trailers and Industrial Trucks Sectional Committee and had been approved by the Transport Engineering Division Council.

This standard was first published in 1974. In this revision, following changes have been incorporated:

- a) References, ICS No. have been updated;
- b) Other editorial changes have been done to bring the standard in the latest style and format of Indian Standards; and
- c) Experience gained with the use of this standard and brings the standard in line with the latest development in the field.

The best controls are those which most closely agree with natural human instinct. Such controls are sometimes called 'directional' where control movement is in the same direction as desired movement of truck or accessory. Some controls such as 'forward' and 'reverse' are obvious and easy to make 'directional'.

Other control movements are less obviously 'directional' and call for a thorough study and/or testing to determine the most natural human reaction. Recommendations for preferred motions and placement of controls are intended to establish uniform practices in this area.

The composition of the Committee responsible for formulation of this standard is given in [Annex A](#).

For the purpose of deciding whether a particular requirement of this standard is complied with, the final value, observed or calculated, expressing the result of a test or analysis, shall be rounded off in accordance with IS 2 : 2022 'Rules for rounding off numerical values (*second revision*)'. The number of significant places retained in the rounded off value should be the same as that of the specified value in this standard.

Indian Standard

SPECIFICATION FOR DIRECTION OF TRAVEL-CONTROLS FOR INDUSTRIAL TRACTORS AND POWERED INDUSTRIAL TRUCKS

(ISO 5053 : 1987, MOD)

(First revision)

1 SCOPE

This standard covers direction of travel-control symbols for use on industrial tractors and various types of industrial trucks.

2 REFERENCE

The standard given below contain provisions which, through reference in this text, constitute provision of this standard. At the time of publication, the edition indicated was valid. All standards are subject to revision, and parties to agreements based on this standard are encouraged to investigate the possibility of applying the most recent edition of this standard.

<i>IS No.</i>	<i>Title</i>
IS 4660 : 1993	Powered industrial trucks — Terminology (<i>third revision</i>)

3 TERMINOLOGY

For the purpose of this standard, the terms and definitions as given in IS 4660 and the following shall apply.

3.1 Central Control — Operating controls provided at the centre of the truck.

3.2 End Control — Operating controls provided at the either end of the truck.

3.3 Pedestrian Controlled Trucks — Trucks where the operator walks along with the truck.

3.4 Sit-On (Rider) Trucks — Trucks where the operator operates the truck while sitting.

3.5 Stand-On (Rider) Trucks — Trucks where the operator operates the truck while standing.

4 FRONT END AND FORWARD DIRECTIONS OF TRAVEL

4.1 Front End of Trucks

The front end of a truck is the end indicated by an arrow in the sketches given under [4.4](#).

4.2 Rear End, Left-Hand and Right-Hand Side of Trucks

These are in conformity with the definition given in [4.1](#).

4.3 Forward Direction of Travel

The forward direction of travel is when the truck travels in the direction indicated by the arrow.

4.4 Nomenclature of Trucks

4.4.1 Sit-on (Rider) Trucks

4.4.1.1 Trucks where the load is leading when the truck travels in the forward direction as given below:

- a) Counterbalanced forklift truck (*see* [Fig. 1](#));
- b) Straddle or reach (with retractable mast or fork) truck (*see* [Fig. 2](#)); and
- c) Shunting tractor (*see* [Fig. 3](#)).

4.4.1.2 Trucks where the load is trailing when the truck travels in the forward direction as given below:

- a) Straddle or reach (with retractable mast or fork) truck where the driver is seated sideways (*see* [Fig. 4](#));
- b) Towing tractor-front end control (*see* [Fig. 5](#));
- c) Towing tractor-rear end control (*see* [Fig. 6](#)); and
- d) Fixed or elevating platform truck (*see* [Fig. 7](#)).

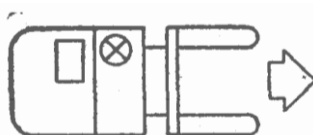

FIG. 1 COUNTERBALANCED FORKLIFT TRUCK

To access Indian Standards click on the link below:

https://www.services.bis.gov.in/php/BIS_2.0/bisconnect/knownyourstandards/Indian_standards/isdetails/

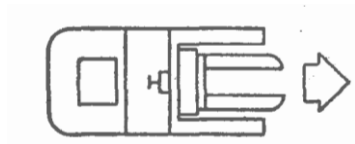

FIG. 2 STRADDLE OR REACH (WITH RETRACTABLE MAST OR FORK) TRUCK

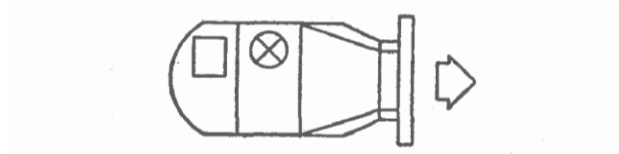

FIG. 3 FORWARD DIRECTION OF SHUNTING TRACTOR

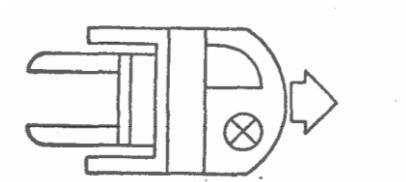

FIG. 4 STRADDLE OR REACH (WITH RETRACTABLE MAST OR FORK)

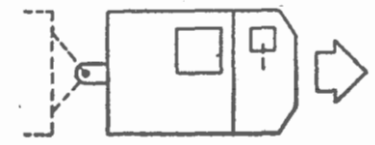

FIG. 5 TOWING TRACTOR-FRONT END CONTROL

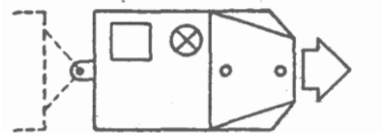

FIG. 6 TOWING TRACTOR-REAR END CONTROL

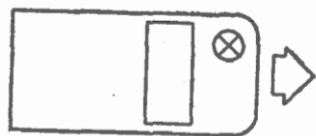

FIG. 7 FIXED OR ELEVATING PLATFORM TRUCK

4.4.2 Stand- On Trucks

4.4.2.1 Centre control

Trucks where the load is leading when the truck travels in the forward direction as given below:

- a) Counterbalanced forklift truck (see [Fig. 8](#)).

4.4.2.2 End control

- a) Trucks where the load is leading when the

truck travels in the forward direction as given below:

- 1) Counter balanced forklift truck (see [Fig. 9](#)); and
- 2) Straddle or reach (with retractable mast or fork) truck (see [Fig. 10](#)).

b) Trucks where the load is trailing when the truck travels in the forward direction as given below:

- 1) Straddle or reach truck (with retractable-mast or fork) with driver standing sideways (see Fig. 11); and
- 2) Fixed or elevating platform truck (see Fig. 12).

4.4.3 Pedestrian Controlled Trucks

Trucks where the load is trailing when the truck travels in the forward direction as given below:

- a) Pallet truck, (see Fig. 13).

b) Fixed or elevating platform truck (see Fig. 14).

c) Counterbalanced forklift truck (see Fig. 15).

d) Tractor (see Fig. 16).

5 STEERING CONTROLS

5.1 Steering Sit-on (Rider) Trucks

5.1.1 All steering controls shall be confined within the plan view outline of the truck, or guarded to prevent injury to the operator during movement of the controls when passing obstacles, walls, columns, etc.

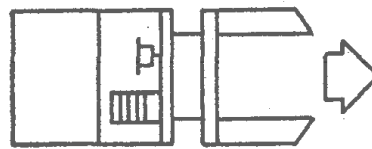

FIG. 8 COUNTERBALANCED FORKLIFT TRUCK

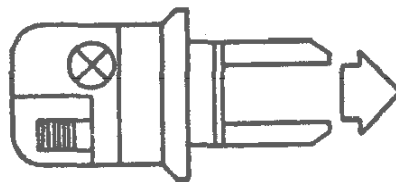

FIG. 9 COUNTERBALANCED FORKLIFT TRUCK

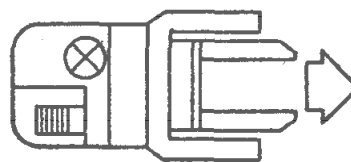

FIG. 10 STRADDLE OR REACH (WITH RETRACTABLE MAST OR FORK)

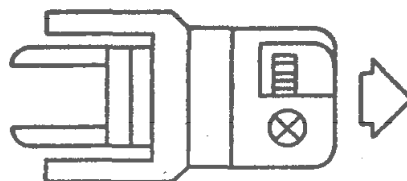

FIG. 11 STRADDLE OR REACH TRUCK (WITH RETRACTABLE-MAST OR FORK) WITH DRIVER STANDING SIDEWAYS

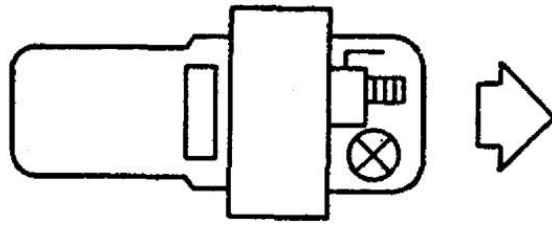

FIG. 12 FIXED OR ELEVATING PLATFORM TRUCK



FIG. 13 PALLET TRUCK

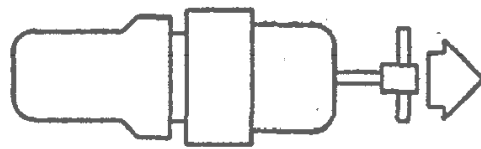

FIG. 14 FIXED OR ELEVATING PLATFORM TRUCK

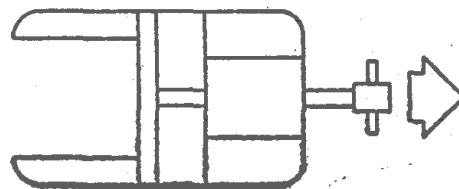

FIG. 15 COUNTERBALANCED FORKLIFT TRUCK

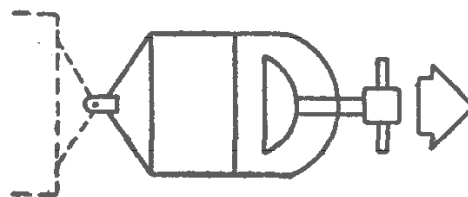

FIG. 16 TRACTOR

5.1.2 Where steering is required to be accomplished with one hand, steering knobs are necessary for safe operation. Steering knobs, when used, shall be mounted within the periphery of the steering hand wheel, and provision shall be made to prevent injury to the operator's hand.

5.2 Steering Wheels

5.2.1 On all trucks, where the operator faces in the normal line of travel, which are steered by means of steering wheels (horizontal, inclined or vertical), a

clockwise rotation of the steering wheel shall steer the truck to the right in the forward direction of travel¹⁾ (see Fig. 17 and 18).

5.2.2 On all trucks where the operator faces at a right angle to the normal direction, of travel which are

steered by means of a steering wheel (horizontal, inclined or vertical) a clockwise rotation of the steering wheel shall steer the truck clockwise when the truck is travelling with the load trailing¹⁾ (see Fig. 19 and 20).

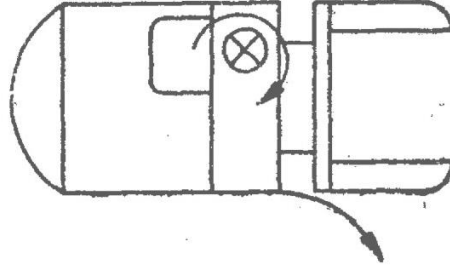

FIG. 17 CLOCKWISE ROTATION OF THE STEERING WHEEL

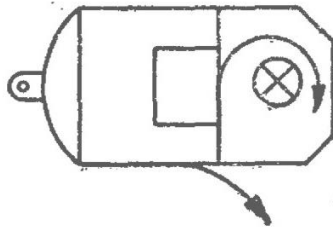

FIG. 18 STEERING TRUCK TO THE RIGHT IN THE FORWARD DIRECTION OF TRAVEL



Fig. 19 TRAVELLING WITH THE LOAD TRAILING

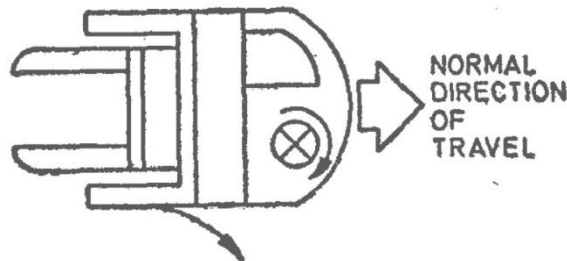

FIG. 20 TRAVELLING WITH THE LOAD TRAILING

¹⁾ Considerable numbers of trucks of models given under 4.4.1.2 and 4.4.2.2 have been built with a steering reverse of the above standard. Such trucks may still be manufactured, provided that on the truck an arrow indicates in which direction the steering control shall be moved to steer the truck to the right in the forward direction of travel.

5.3 Tillers

5.3.1 Tillers Operating in a Horizontal Plane

On trucks steered by a tiller moving in the horizontal plane and which in the neutral position is parallel to the longitudinal axis of the truck, or steered by a tiller rotating on a shaft parallel to the longitudinal axis of the truck and which in the neutral position stands upright (see Fig. 21).

When the driver is facing in the direction of travel, movement of the tiller to his right shall steer the truck to his right (see Fig. 22).

5.3.2 Tillers Operating in a Vertical Plane

On stand-on lift platform trucks [see 4.4.2.2(b)] and fixed platform trucks which are steered by means of a tiller situated on the right of the driver and operating in a vertical plane, raising the tiller (clockwise rotating shall steer the truck to the right) in the forward direction of travel²⁾ (see Fig. 23).

5.4 Steering Handle — Motorized Hand/Rider Trucks

5.4.1 Steering handle shall be provided with suitable means to protect operator's hands against injury from swinging doors, walls, columns, etc.

5.4.2 Motorized hand/rider trucks employing a steering tongue control which extends beyond the

confines of the truck shall steer as follows:

- a) With the walking operator facing in the direction of travel, with load trailing, clockwise movement of the steering tongue shall steer the truck clockwise; and
- b) With the riding operator facing in the direction of travel, with the load trailing, clockwise movement of the steering tongue shall steer the truck clockwise.

5.5 Pivoting Steering Controls

On trucks which are steered by means of a pivoting control operated by foot (see Fig. 24), or by hand (see Fig. 25), a clockwise rotation of this control, looking in the forward direction of travel, shall steer the truck to the right.

6 DRIVING AND BRAKING CONTROLS

6.1 Sit-Down Rider Trucks

6.1.1 Pedals Arrangement

The accelerator, brake and clutch pedals (when fitted) of internal combustion engine and electric powered trucks shall be arranged according to Fig. 26 and 27 respectively.

Where the pedal control system differs from Fig. 26 and 27, its function shall be clearly indicated both in the driving instructions and on truck itself.

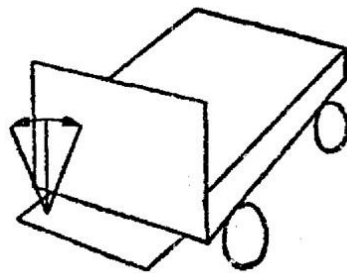

FIG. 21 NEUTRAL POSITION STANDS UPRIGHT

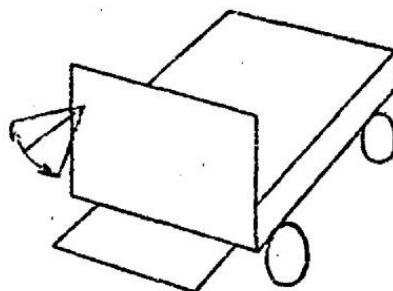

FIG. 22 STEERING THE TRUCK TO DRIVER'S RIGHT

²⁾ Considerable numbers of trucks of models given under 4.4.1.2 and 4.4.2.2 have been built with a steering reverse of the above standard. Such trucks may still be manufactured, provided that on the truck an arrow indicates in which direction the steering shall be moved to steer the truck to the right in the forward direction of travel.

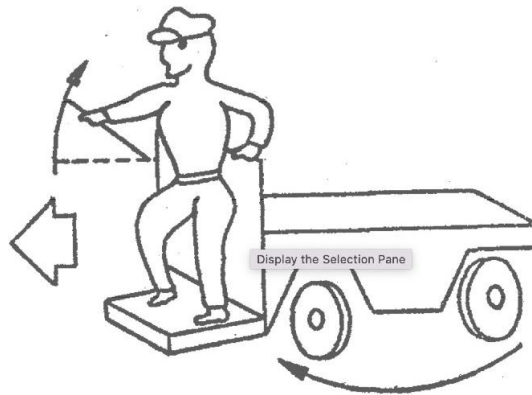

FIG. 23 CLOCKWISE ROTATING OF STEERING



FIG. 24 PIVOTING CONTROL OPERATED BY FOOT

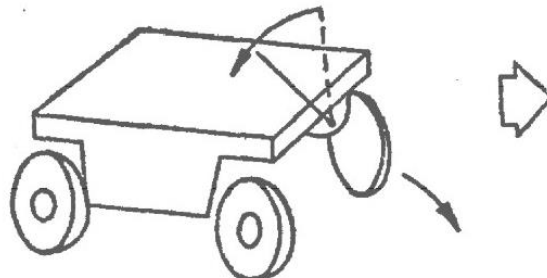

FIG. 25 PIVOTING CONTROL OPERATED BY HAND

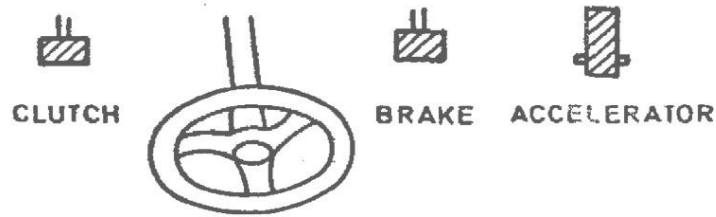

FIG. 26 CLUTCH, STEERING, BRAKE AND ACCELERATOR

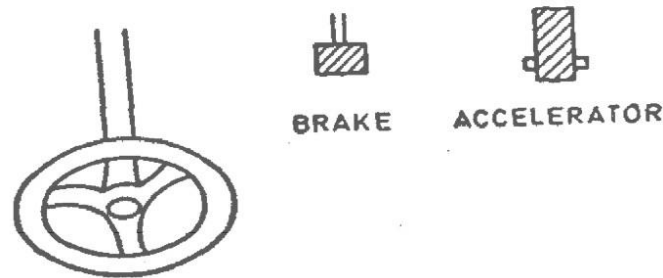

FIG. 27 STEERING, BRAKE AND ACCELERATOR

6.1.2 Gear Change Lever

The positions for gear engagement shall be clearly indicated.

6.1.3 Direction Change Levers

The direction control levers on internal combustion engined trucks and the controller levers on electric trucks shall be arranged in such a way that their operation corresponds to the required direction of travel (see Fig. 28).

6.1.4 Safety Control and Brakes

Electric powered industrial trucks-means shall be provided to open the travel circuit when the operator leaves the truck.

6.1.4.1 Travel control having a neutral position in the direction control shall be so arranged that the truck moves only when the direction control is actuated and shall not move at a speed greater than inching speed unless control has been actuated for both speed and direction. Where no neutral position is provided, the truck shall not move unless the speed control is activated.

6.1.4.2 Accelerator, if foot operated, shall increase speed when depressed with the right foot.

6.1.4.3 Service brakes, if foot operated, shall be energized by depressing the control by the right foot. Where the pedal control system differs from this, its function shall be clearly indicated both in the driving instructions and on the truck itself.

6.1.4.4 If a single pedal controls both acceleration and braking, depressing pedal shall increase speed and releasing pedal shall apply brakes, when the pedal is being operated by the right foot.

6.1.4.5 The parking brake (or mechanism) shall be manually or automatically applied and shall remain applied until released by the operator.

6.1.5 Safety Control and Brakes for Internal Combustion Engine Powered Industrial Trucks

Travel control, having a neutral position in the direction control shall be so arranged that the truck moves only when the direction control is actuated and shall not move at a speed greater than inching speed, unless, control has been actuated for both speed and direction. Where no neutral position is provided, the truck shall not move unless the speed control is activated.

6.1.5.1 Service brakes, if foot operated, shall be energized by depressing the control.

6.1.5.2 If a combination clutch and brake pedal is used, the initial pedal movement shall disengage the clutch and the final pedal movement shall apply the brakes and the pedal shall be operated by the left foot.

6.1.5.3 Accelerator, if foot operated, shall increase speed when depressed with the right foot.

6.1.5.4 If a combination pedal controls both acceleration and brakes depressing the accelerator portion shall increase speed and depressing the brake portion shall apply the brakes and the

combination pedal shall be operated by the right foot.

6.1.5.5 Clutch pedal, if used, shall release clutch by depressing with left foot.

6.1.5.6 The parking brake (or mechanism) shall be manually or automatically applied and shall remain applied until released by the operator.

6.2 Stand-On (Rider) Trucks

6.2.1 Pedals

When the truck is in motion, operator's foot shall remain on the pedal and by releasing the pedal, the brakes are applied (see Fig. 29).

6.2.2 Levers

The provisions of [6.1.2](#) and [6.1.3](#) shall also apply to stand-on trucks.

Where a lever is provided, depressing the lever shall release the brakes. When the truck is in motion, operator's hand shall remain on the lever. Releasing the lever shall apply the brakes (see [Fig. 30](#)).

6.2.3 Push-Buttons

6.2.3.1 When direction of travel is selected by push-buttons arranged vertically one above the other, pressing the upper button shall drive the truck in the forward direction of travel as defined in [4.3](#) (see [Fig. 31](#)).

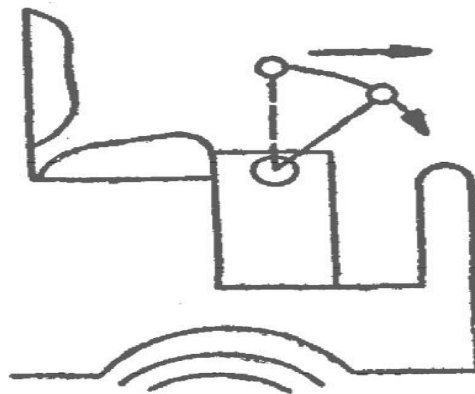

FIG. 28 DIRECTION CONTROL LEVERS

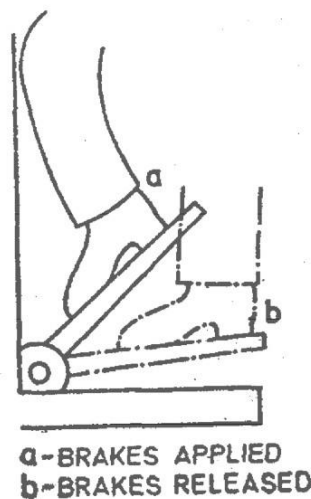

FIG. 29 BRAKES APPLIED AND RELEASED

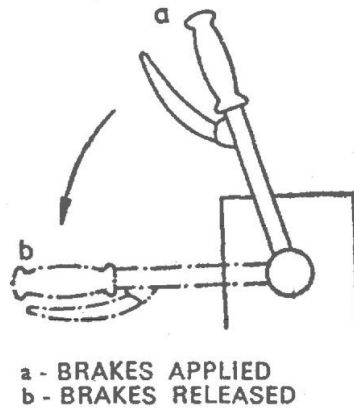

FIG. 30 BRAKES APPLIED AND RELEASED

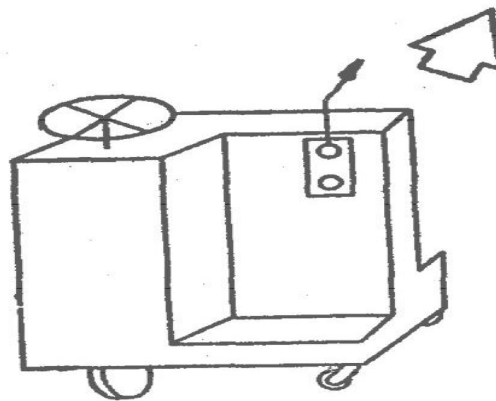

FIG. 31 FORWARD DIRECTION OF TRAVEL CONTROL

6.2.3.2 When direction of travel is selected by push-buttons arranged horizontally, the direction controlled by each button shall be clearly indicated.

6.2.3.3 All direction control, push-buttons shall return to neutral position when released.

6.2.4 *Safety Control and Brakes for Electric Powered Industrial Trucks*

6.2.4.1 Means shall be provided to automatically open the travel circuit when the parking brake (or mechanism) is applied.

6.2.4.2 Means shall be provided so that the travel circuit may be activated only by releasing the parking brake and resetting the speed and/or direction control(s) when the operator assumes the driving position.

6.2.4.3 The parking brake (or mechanism) shall be manually or automatically applied and shall remain

applied until released by the operator.

6.2.4.4 Means shall be provided for mechanical or electrical interlocking for the forward and reverse motion.

6.2.5 *Safety Control and Brakes for Internal Combustion Engine Powered Industrial Trucks*

6.2.5.1 Accelerator, if foot operated, shall increase speed when depressed with the right foot.

6.2.5.2 Travel control shall be so arranged that the truck does not move until the direction control has been actuated and shall not move, at a speed greater than inching speed, unless control has been actuated for both speed and direction.

6.2.5.3 The parking mechanism shall be manually or automatically applied. It shall remain applied until released by the operator.

6.3 Pedestrian Controlled Trucks

6.3.1 Electric Trucks

Forward and reverse motion of the truck shall be controlled or selected by means of a control device readily accessible when grasping handle grip on steering tongue. This control device shall operate directionally in one of the following manners:

- a) The control shall have a forward motion for forward travel and a rearward motion for reverse travel; or
- b) The control shall consist of two buttons located at top of control handle when steering tongue is approximately vertically arranged so that the forward one is for

forward travel and vice-versa (see Fig. 32); or

- c) The control shall have rotary motion, the rotation being in the same direction as drive wheel rotation (see Fig. 33).

6.3.1.1 The travel control shall be clearly and durably identified to indicate the function and direction of motion.

6.3.1.2 On electric trucks, the tongue shall be movable in a vertical plane. When the brake is mechanically operated in the vertical (B) and horizontal (B') positions, the brake shall be applied and the power switched off, unless it has already been switched off by the operation of the travel control switch (see Fig. 34).

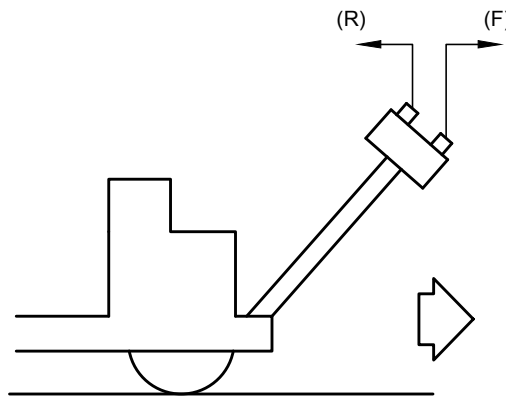

FIG. 32 CONTROL FOR ORWARD TAVEL AND VICE VERSA

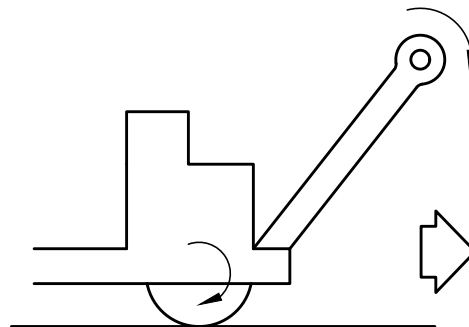

FIG. 33 CONTROL FOR ROTATORY MOTION

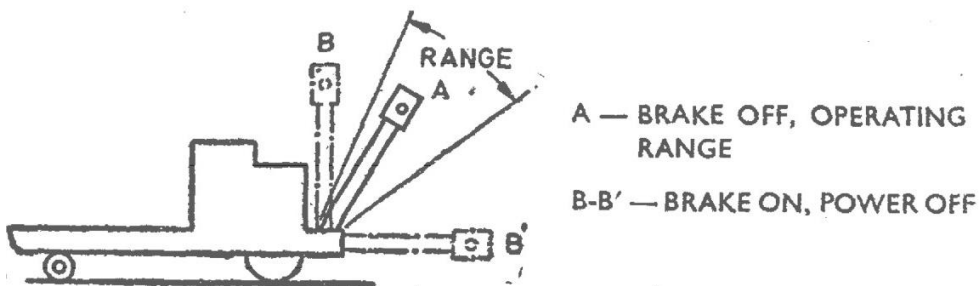

FIG. 34 TRAVEL CONTROL SWITCH

6.3.1.3 When the brake is electrically operated, the release of the tongue or of the travel control switch shall automatically cut off the power and shall apply the brake, whatever be the position of the handle.

NOTE — The requirements of [6.3.1.2](#) do not preclude controlled 'free-wheeling' when the power is off.

6.3.2 Internal Combustion Engine Powered Trucks

The tiller shall be movable in vertical plane. When the brake is operated in vertical (B) and horizontal (B') positions, the brake shall be applied and the power switched off, unless it has already been switched off by the operation of the travel control switch or clutch (*see* [Fig. 35](#)).

6.4 High Lift Order Picker Trucks

6.4.1 Safe Control and Brakes

6.4.1.1 Controls shall be provided which de-activate travel controls when the operator leaves the truck.

6.4.1.2 Means shall be provided to render inoperative all operating controls other than those on the elevatable platform when the controls on the elevatable platform have been selected for use. Only one location of controls shall be capable of being operated at one time.

6.4.1.3 Means shall be provided for an operator on the elevatable platform to shut off the power to the truck.

6.4.1.4 Travel controls shall be so arranged that the truck may move only when the direction and speed controls have been actuated. Travel speed shall be such that at all operating platform heights the

stability requirements of the relevant Indian Standards are complied with.

6.4.1.5 The parking mechanism shall be manually or automatically applied and shall remain applied until released by the operator.

7 CONTROLS FOR THE MOVEMENT OF LOADS

7.1 Control by Levers³⁾

7.1.1 Location

The levers shall preferably be located so as to be operated by the driver's right hand, and clearly separated from the drive controls.

Control symbols shall be applied on or in close proximity to the control levers.

7.1.2 Vertical Levers³⁾

7.1.2.1 When the control levers are operated in a vertical plane the nearest to the driver (A) shall be for lifting and lowering the load, the next one (B) for tilting the load forward and backward. Other lever (C), if necessary, shall be used for controlling auxiliary devices (*see* [Fig. 36](#)).

7.1.2.2 In the event of a single lever and gate being used, its sequence of operation shall be as indicated in [7.1.2.1](#).

7.1.2.3 On fork trucks with retractable mast or fork, the second lever (B') shall be used for the displacement of the mast or fork. The third lever (B) shall be used for tilting if provided and the other (C) for auxiliary devices (*see* [Fig. 37](#)).

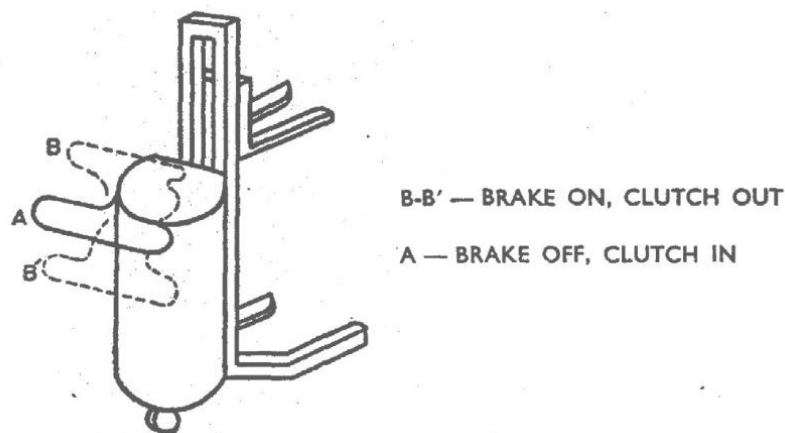

FIG. 35 TRAVEL CONTROL SWITCH

7.1.3 Horizontal Lever³⁾

7.1.3.1 When the control levers are operated in a horizontal plane (under the steering wheel, for instance), the highest (A) shall be for lifting and lowering the load, that immediately below (B) for tilting mast, and the other under this (C) for controlling auxiliary devices (see Fig. 38).

7.1.3.2 In the event of a single lever and gate being used, its sequence of operation shall be as indicated in 7.1.3.1.

7.1.3.3 On fork trucks with retractable mast or fork, the second lever (B') shall be used for the displacement of the mast or fork. The third lever (B) shall be used for tilting if provided and the other (C) for auxiliary devices (see Fig. 39).

7.1.4 Movement³⁾

7.1.4.1 In the case of levers located as prescribed in 7.1.2 and 7.1.3, lifting shall be effected by pulling the lever (A) and lowering by pushing it. Backward tilt shall be effected by pulling the lever (B) and forward tilt by pushing it (see Fig. 40).

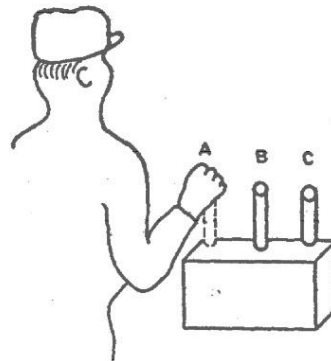

FIG. 36 CONTROL LEVERS

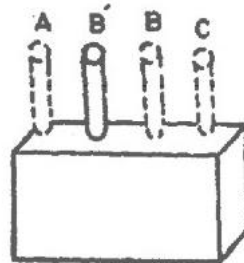

FIG. 37 CONTROL LEVERS

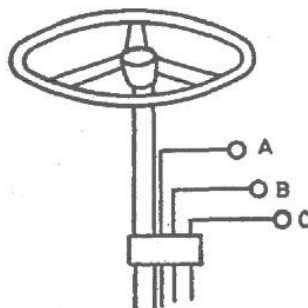

FIG. 38 CONTROL LEVERS STEERING WHEEL

³⁾ If it is not possible to comply with the requirements of 7.1.1 to 7.1.4, the function and mode of operation of the levers shall be clearly indicated.

7.1.4.2 In the case of a single lever located under the steering wheel, and working in a 'type-selector gate' its operation in the vertical plane shall be for lifting [up (H) for lifting and down (II) for lowering] and in the horizontal plane for tilting [pull (E) for backward and push (F) for forward tilting] (see Fig. 41).

7.1.4.3 On fork trucks with retractable mast or fork, retracting shall be effected by pulling the lever (B') and extending by pushing it (see Fig. 42).

7.1.5 Auxiliary Devices

The operation of control levers devices shall be as far as possible instinctive as explained below:

Examples:

- a) Clamps — Pull lever to close arms, push lever to open arms (see Fig. 43);
- b) Rotating hand — Pull lever to see the head rotate clockwise, push lever to see it rotate anti-clockwise (see Fig. 44);
- c) Tipping scoop — Pull lever to return scoop, push lever to tip scoop (see Fig. 45); and
- d) Side-shifter — Pull lever to see fork shift to the right of the driver (see Fig. 46).

7.1.6 Identification

When there are several levers, each lever shall be clearly and durably marked to indicate the individual function.

7.1.7 Self-Centring

All levers shall be self-centring.

7.2 Control by Push Buttons

Where the operation of lifting, lowering, tilting and auxiliary devices is controlled by push-buttons, these shall be arranged in such a way that they may be operated by the hand which is not being used to operate the steering control. The function of each button shall be clearly and durably indicated.

Where the operation of lifting, lowering, tilting and/or auxiliary devices is controlled by a pair of push-buttons, they shall operate in the same sense as described in 6.2. For example, actuation of the button that is located to the rear relative to the operator's position shall serve the same function as motion of a control lever to the rear.

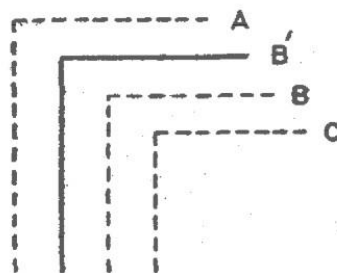

FIG. 39 AUXILIARY DEVICES

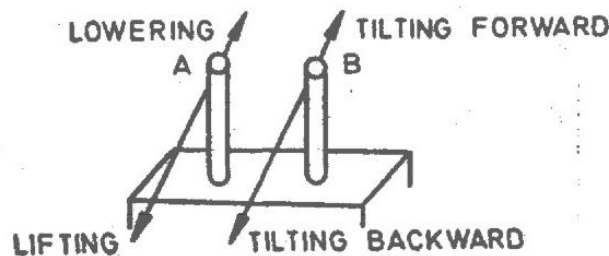

FIG. 40 LEVERS

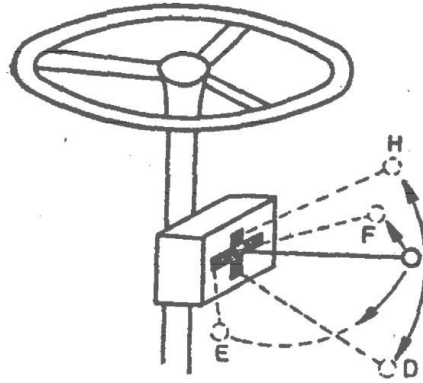

FIG. 41 STEERING WHEEL FUNCTION

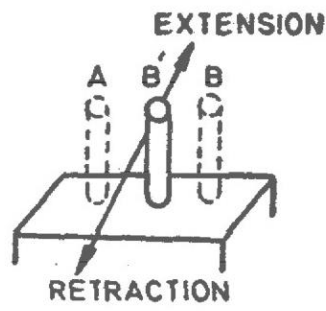

FIG. 42 LEVERS

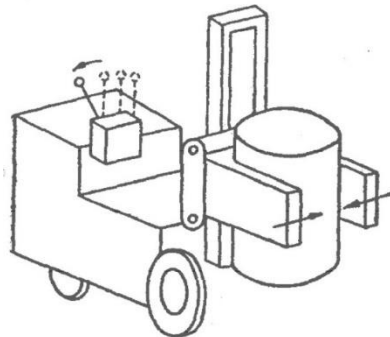

FIG. 43 CLAMPS

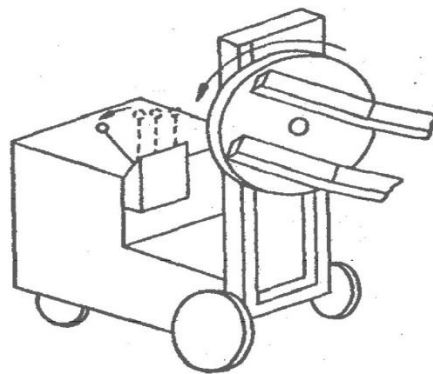

FIG. 44 ROTATING HAND

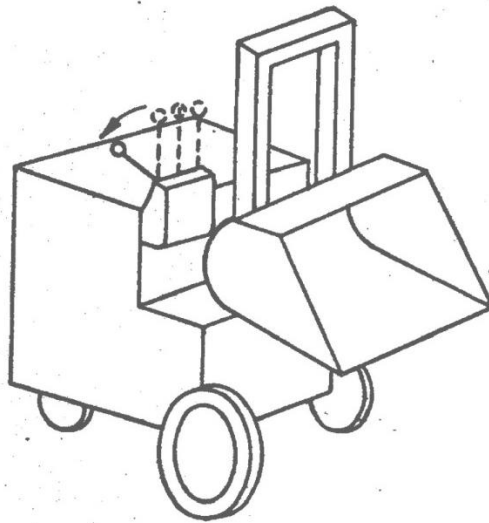

FIG. 45 TIPPING SCOOP

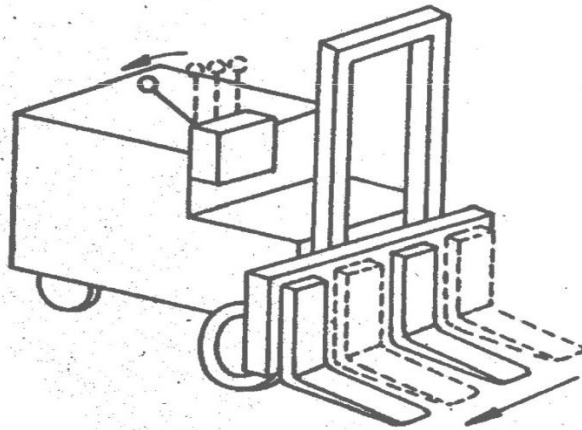

FIG. 46 SIDE SHIFTER

7.3 Rotary Controls

The upper surface of a rotary control device shall move in the same sense direction as levers.

7.4 Special Controls

Special controls (such as for pre selective or

automatic devices) shall be identified easily and shall preferably be in accordance with the above recommendations.

ANNEX A

(Foreword)

COMMITTEE COMPOSITION

Transport Tractors, Trailers and Industrial Trucks Sectional Committee, TED 22

<i>Organization</i>	<i>Representative(s)</i>
Automotive Research Association of India, Pune	SHRI A. AKBAR BADUSHA (<i>chairperson</i>)
BEML Ltd, Bengaluru	SHRI RAMESH RAJU SHRI SETHU MADHAVAN (<i>Alternate</i>)
Action Construction Equipment Limited, Palwal	SHRI CHETAN GOLE SHRI INDERPAL SINGH BENIWAL (<i>Alternate</i>)
All India Motor Transport Congress, New Delhi	SHRI NAVEEN GUPTA SHRI S. K. MITTAL (<i>Alternate</i>)
Ashok Leyland Limited, Chennai	SHRI PRASANNA VENKATESH SHRI FAUSTINO V. (<i>Alternate</i>)
Automotive Component Manufactures Association of India, New Delhi	SHRI SANJAY TANK SHRI SEEMA BABAL (<i>Alternate</i>)
Automotive Research Association of India, Pune	SHRI P. D. BETGERI SHRI TUSHARKUMAR R. KAMBLE (<i>Alternate</i>)
Brakes India Limited, Chennai	SHRI P. VENUGOPAL SHRI G. DEVENDRAN (<i>Alternate</i>)
Central Institute of Road Transport, Pune	SHRI S. N. DHOLE SHRI S. N. GUTTE (<i>Alternate</i>)
Chennai Port Trust, Chennai	SHRI N. A. KAMATH
Container Corporation of India, New Delhi	THE GENERAL MANAGER (TECH) SHRI V. RAM DOSS (<i>Alternate</i>)
Directorate General Factory Advice Service and Labour Institutes, Mumbai	SHRI H. CHATTOPADHAYAYA
Godrej & Boyce Manufacturing Company Limited, Mumbai	SHRI VINAY G. KULKARNI SHRI ANAND SHANKAR TAWDE (<i>Alternate</i>)
JCB India Limited, New Delhi	SHRI SAURABH DALELA SHRI ALOK GANDHI (<i>Alternate</i>)
Josts Engineering Company Limited, Thane	SHRI PROMOD M. POHALE SHRI SANTOSH SARAF (<i>Alternate</i>)
KION India Private Limited, Pune	SHRI SUNIL K. GUPTA SHRI RIZWAN KHAN (<i>Alternate</i>)
Knorr-Bremse Systems for Commercial Vehicles India Private Limited, Pune	SHRI ARUN BISH SHRI ATUL INGOLE (<i>Alternate</i>)

<i>Organization</i>	<i>Representative(s)</i>
Machine and Mill Stores Corporation Private Limited, Howrah	SHRI DEEPAK GHOSH SHRI SUBHAM GOSH (<i>Alternate</i>)
Mahindra Trucks and Bus Division, Pune	SHRI NAGARAJU K. SHRI V. G. KULKARNI (<i>Alternate</i>)
Ministry of Heavy Industries and Public Enterprises, Department of Heavy Industry, New Delhi	SHRI B. K. MISHRA SHRI R. K. JAISWAL (<i>Alternate</i>)
Ministry of Labour and Employment Directorate, Mumbai	DR R. N. MEENA SHRI K. Durai (<i>Alternate</i>)
Ministry of Road Transport and Highways, New Delhi	SHRI A. KANNAN SHRIMATI DHARKAT R. LUIKANG SHRI SAM SHAIKH (<i>Alternate</i>)
PL Haulwel Trailers, New Delhi	SHRI MANOJ VARGHESE
SDR Auto Private Limited, Chennai	SHRI B. RAMESH SHRI PRAVEEN KUMAR (<i>Alternate</i>)
Tata Motors Limited, Pune	SHRI RAHUL MOHANRAO PATHAK SHRI SUNIL AGARWAL (<i>Alternate</i>)
TRATEC Engineering Pvt Ltd, Gurugram	SHRI KAMAL KHOSLA SHRI C. RAJASEKHAR (<i>Alternate</i>)
Volvo Construction Equipment India Private Limited, Bengaluru	SHRI V. R. SAI PRASAD POLIPALLI
ZF Commercial Vehicle Control Systems India Limited, Pune Industry	SHRI PRABHAKARAN DURAIRAJ SHRI SACHIN DESHMUKH (<i>Alternate</i>)
BIS Directorate General	SHRI R. R. SINGH, SCIENTIST 'F'/ SENIOR DIRECTOR AND HEAD (TRANSPORT ENGINEERING) [REPRESENTING DIRECTOR GENERAL (<i>Ex-officio</i>)]

Member Secretary
SHRI MITRA SEN VERMA
SCIENTIST 'D'/JOINT DIRECTOR
(TRANSPORT ENGINEERING), BIS

Bureau of Indian Standards

BIS is a statutory institution established under the *Bureau of Indian Standards Act, 2016* to promote harmonious development of the activities of standardization, marking and quality certification of goods and attending to connected matters in the country.

Copyright

BIS has the copyright of all its publications. No part of these publications may be reproduced in any form without the prior permission in writing of BIS. This does not preclude the free use, in the course of implementing the standard, of necessary details, such as symbols and sizes, type or grade designations. Enquiries relating to copyright be addressed to the Head (Publication & Sales), BIS.

Review of Indian Standards

Amendments are issued to standards as the need arises on the basis of comments. Standards are also reviewed periodically; a standard along with amendments is reaffirmed when such review indicates that no changes are needed; if the review indicates that changes are needed, it is taken up for revision. Users of Indian Standards should ascertain that they are in possession of the latest amendments or edition by referring to the website-www.bis.gov.in or www.standardsbis.in.

This Indian Standard has been developed from Doc No.: T D 22 (19045).

Amendments Issued Since Publication

Amend No.	Date of Issue	Text Affected

BUREAU OF INDIAN STANDARDS

Headquarters:

Manak Bhavan, 9 Bahadur Shah Zafar Marg, New Delhi 110002

Telephones: 2323 0131, 2323 3375, 2323 9402

Website: www.bis.gov.in

Regional Offices:

Central : 601/A, Konnectus Tower -1, 6th Floor,
DMRC Building, Bhavbhuti Marg, New
Delhi 110002

Telephones

{ 2323 7617

Eastern : 8th Floor, Plot No 7/7 & 7/8, CP Block, Sector V,
Salt Lake, Kolkata, West Bengal 700091

{ 2367 0012
{ 2320 9474

Northern : Plot No. 4-A, Sector 27-B, Madhya Marg,
Chandigarh 160019

{ 265 9930

Southern : C.I.T. Campus, IV Cross Road, Taramani, Chennai 600113

{ 2254 1442
{ 2254 1216

Western : 5th Floor/MTNL CETTM, Technology Street, Hiranandani Gardens, Powai
Mumbai 400076

{ 25700030
{ 25702715

Branches : AHMEDABAD, BENGALURU, BHOPAL, BHUBANESHWAR, CHANDIGARH, CHENNAI, COIMBATORE, DEHRADUN, DELHI, FARIDABAD, GHAZIABAD, GUWAHATI, HARYANA (CHANDIGARH), HUBLI, HYDERABAD, JAIPUR, JAMMU, JAMSHEDPUR, KOCHI, KOLKATA, LUCKNOW, MADURAI, MUMBAI, NAGPUR, NOIDA, PARWANOO, PATNA, PUNE, RAIPUR, RAJKOT, SURAT, VIJAYAWADA.