

---

---

प्रकाशिकी और फोटोनिक्स — सूक्ष्म लेंस  
सरणियाँ

भाग 2 वेव फ्रंट विरूपण की परीक्षण पद्धतियाँ

Optics and Photonics — Microlens  
Arrays

Part 2 Test Methods for Wave Front  
Aberrations

ICS 31.260

© BIS 2024

© ISO 2006



भारतीय मानक ब्यूरो  
BUREAU OF INDIAN STANDARDS  
मानक भवन, 9 बहादुर शाह ज़फर मार्ग, नई दिल्ली - 110002  
MANAK BHAVAN, 9 BAHADUR SHAH ZAFAR MARG  
NEW DELHI - 110002

[www.bis.gov.in](http://www.bis.gov.in) [www.standardsbis.in](http://www.standardsbis.in)

## NATIONAL FOREWORD

This Indian Standard (Part 2) which is identical to ISO 14880-2 : 2006 'Optics and photonics — Microlens arrays — Part 2: Test methods for wave front aberrations' issued by the International Organization for Standardization (ISO) was adopted by the Bureau of Indian Standards on the recommendation of the Optics and Photonics Sectional Committee and approval of the Production and General Engineering Division Council.

The market in microlens arrays is generating an urgent need for agreement on basic terminology and test methods for a definition of the microlens array itself. Standard terminology and a clear definition are needed not only to promote applications but also to encourage scientists and engineers to exchange ideas and new concepts based on common understanding. Considering this the optics and photonics sectional Committee decided to adopt the ISO 14880-1 as an Indian Standard.

This standard has been published in 5 parts. The other parts in this series are:

- Part 1      Vocabulary
- Part 3      Test methods for optical properties other than wave front aberrations
- Part 4      Test methods for geometrical properties
- Part 5      Guidance on testing

The text of ISO standard has been approved as suitable for publication as an Indian Standard without deviations. Certain conventions are, however, not identical to those used in Indian Standards. Attention is particularly drawn to the following:

- a) Wherever the words 'International Standard' appear referring to this standard, they should be read as 'Indian Standard'; and
- b) Comma (,) has been used as a decimal marker while in Indian Standards, the current-practice is to use a point (.) as the decimal marker.

In this adopted standard, reference appears to the following International Standard for which Indian Standard also exists. The corresponding Indian Standard which is to be substituted in its place is given below along with its degree of equivalence for the edition indicated.

<i>International Standard</i>	<i>Corresponding Indian Standard</i>	<i>Degree of Equivalence</i>
ISO 14880-1    Optics and photonics — Microlens arrays — Part 1: Vocabulary	IS 18726 (Part 1) : 2024/ ISO 14880-1 : 2019 Optics and photonics — Microlens arrays: Part 1 Vocabulary	Identical

In reporting the result of a test or analysis made in accordance with this standard, if the final value, observed or calculated, expressing the result of a test or analysis, shall be rounded off in accordance with IS 2 : 2022 'Rules for rounding off numerical values (*second revision*)'. The number of significant places retained in the rounded off value should be the same as that of the specified value in this standard.

# Contents

Page

Introduction .....	iv
<b>1</b> <b>Scope</b> .....	<b>1</b>
<b>2</b> <b>Normative references</b> .....	<b>1</b>
<b>3</b> <b>Terms and definitions</b> .....	<b>1</b>
<b>4</b> <b>Symbols and abbreviated terms</b> .....	<b>1</b>
<b>5</b> <b>Apparatus</b> .....	<b>2</b>
<b>5.1</b> <b>General</b> .....	<b>2</b>
<b>5.2</b> <b>Standard optical radiation source</b> .....	<b>2</b>
<b>5.3</b> <b>Standard lens</b> .....	<b>2</b>
<b>5.4</b> <b>Collimator</b> .....	<b>2</b>
<b>5.5</b> <b>Beam reduction optical system</b> .....	<b>2</b>
<b>5.6</b> <b>Aperture stop</b> .....	<b>3</b>
<b>6</b> <b>Test principle</b> .....	<b>3</b>
<b>7</b> <b>Measurement arrangement</b> .....	<b>3</b>
<b>7.1</b> <b>Measurement arrangement for single microlenses</b> .....	<b>3</b>
<b>7.2</b> <b>Measurement arrangement for microlens arrays</b> .....	<b>3</b>
<b>7.3</b> <b>Geometrical alignment of the sample</b> .....	<b>4</b>
<b>7.4</b> <b>Preparation</b> .....	<b>4</b>
<b>8</b> <b>Procedure</b> .....	<b>4</b>
<b>9</b> <b>Evaluation</b> .....	<b>4</b>
<b>10</b> <b>Accuracy</b> .....	<b>4</b>
<b>11</b> <b>Test report</b> .....	<b>5</b>
<b>Annex A</b> (normative) <b>Measurement requirements for test methods for microlenses</b> .....	<b>6</b>
<b>Annex B</b> (normative) <b>Microlens test Methods 1 and 2 using Mach-Zehnder interferometer systems</b> .....	<b>8</b>
<b>Annex C</b> (normative) <b>Microlens test Methods 3 and 4 using a lateral shearing interferometer system</b> .....	<b>13</b>
<b>Annex D</b> (normative) <b>Microlens test Method 5 using a Shack-Hartmann sensor system</b> .....	<b>18</b>
<b>Annex E</b> (normative) <b>Microlens array test Method 1 using a Twyman-Green interferometer system</b> ....	<b>20</b>
<b>Annex F</b> (normative) <b>Measurement of uniformity of microlens array determined by test Method 2</b> .....	<b>22</b>
<b>Bibliography</b> .....	<b>25</b>

## Introduction

This part of ISO 14880 specifies methods of testing wavefront aberrations for microlens arrays. Examples of microlens array applications include three-dimensional displays, coupling optics associated with arrayed optical radiation sources and photo-detectors, enhanced optics for liquid crystal displays, and optical parallel processor elements.

The market in microlens arrays is generating an urgent need for agreement on basic terminology and test methods for a definition of the microlens array itself. Standard terminology and a clear definition are needed not only to promote applications but also to encourage scientists and engineers to exchange ideas and new concepts based on common understanding.

Microlenses are used as single lenses and in arrays of two or more lenses. The characteristics of the lenses are fundamentally evaluated with a single lens. Therefore, it is important that the basic characteristic of a single lens can be evaluated first. However, if a large number of lenses is formed on a single substrate, the measurement of the whole array will incur a lot of time and cost. Furthermore, methods for measuring lens shapes are essential as a production tool.

Appraisal methods of the characteristic parameters are defined by ISO 14880-1, *Vocabulary*. It has been completed by a set of three other International Standards, i.e. Part 2, *Test methods for wavefront aberrations*, Part 3, *Test methods for optical properties other than wavefront aberrations* and Part 4, *Test methods for geometrical properties*.

This part of ISO 14880 specifies methods for measuring wavefront quality. Wavefront quality is the basic performance characteristic of a microlens. Characteristics other than wavefront aberrations are specified in ISO 14880-3 and ISO 14880-4.

*Indian Standard*

OPTICS AND PHOTONICS — MICROLENS ARRAYS  
 PART 2 TEST METHODS FOR WAVE FRONT ABERRATIONS

**1 Scope**

This part of ISO 14880 specifies methods for testing wavefront aberrations for microlenses within microlens arrays. It is applicable to microlens arrays with very small lenses formed inside or on one or more surfaces of a common substrate.

**2 Normative references**

The following referenced documents are indispensable for the application of this document. For dated references, only the edition cited applies. For undated references, the latest edition of the referenced document (including any amendments) applies.

ISO 14880-1:2001, *Optics and photonics — Microlens arrays — Part 1: Vocabulary*

**3 Terms and definitions**

For the purposes of this document, the terms and definitions given in ISO 14880-1 apply.

**4 Symbols and abbreviated terms**

**Table 1 — Symbols, abbreviated terms and units of measure**

Symbol	Unit	Term
$\Phi$	$\lambda$	wavefront aberration
$\Phi_{P-V}$	$\lambda$	peak-to-valley value of wavefront aberration
$\Phi_{rms}$	$\lambda$	root-mean-square value of wavefront aberration
$\lambda$	$\mu\text{m}$	wavelength
$\theta$	degree	acceptance angle
NA	none	numerical aperture

## 5 Apparatus

### 5.1 General

The test system consists of a source of optical radiation, a collimator lens, a method of limiting the measurement aperture, a sample holding apparatus, imaging optics, an image sensor and an interference pattern analyser system.

### 5.2 Standard optical radiation source

A source of optical radiation shall be used, which is suitable for the testing of wavefront aberrations of microlenses. The aberrations of the wavefront at the operational wavelength impinging on the test equipment shall have a rms deviation of  $\leq \lambda/10$  over the effective aperture of the microlens to be tested.

Properties of the source to be specified include centre wavelength, half-width of the spectrum, the type of optical radiation source, states of polarization (randomly polarized optical radiation, linearly polarized optical radiation, circularly polarized optical radiation, etc.), radiance angle (in mrad), spot size or beam waist parameters. Otherwise, the specification of the radiation source shall be described in the documentation of the experimental results.

NOTE 1 Usually, He-Ne gas lasers are used. Other gas lasers, solid-state lasers, semiconductor lasers (LD), and light emitting diodes (LED) are also used.

NOTE 2 LDs and LEDs are used together with a suitable optical wavefront aberration compensation system.

### 5.3 Standard lens

Where a standard lens is used as a reference or for generating an ideal spherical wave, the wavefront aberrations of the standard lens shall be smaller by at least one order of magnitude compared to that of the lens to be tested or shall be  $\leq \lambda/10$  rms deviation.

The objective lens of an optical microscope used as the standard lens shall be specified with the effective numerical aperture. The following shall be given:

- effective aperture;
- effective focal length at the operational wavelength.

The test geometry for the measurement of the wavefront aberrations is restricted to the case  $\infty/f$  for the conjugates of the lens.

### 5.4 Collimator

The collimator optics shall have a numerical aperture greater than the maximum numerical aperture of the test sample sufficient to avoid effects due to diffraction. The wavefront aberrations shall be less than  $\lambda/20$  rms deviation at the operational wavelength.

Otherwise the specification used should be described in the test report.

### 5.5 Beam reduction optical system

A telescopic system consisting of two positive lenses in an afocal arrangement is used for the adaptation of the beam cross-section to the array detector. The ratio of the focal lengths gives the reduction factor.

NOTE The diameter of the evaluated lens area can be set to the effective aperture by software to avoid additional diffraction at a physical aperture.

## 5.6 Aperture stop

A physical stop is placed in the optical radiation beam of the test equipment to limit the diameter of the optical radiation beam incident on the lens to be tested. Alternatively the stop may be realized by a truncation software during evaluation.

## 6 Test principle

The wavefront aberrations of the test microlens shall be determined with an interferometer or another wavefront test device as described in the Annexes. When small-diameter Gaussian beams are used, care should be taken because geometrical optics does not apply to the propagation of such beams. The detector surface shall be conjugate with the entrance or exit pupil of the test microlens. An aperture is used to analyse the data for the wave aberrations.

The test method shall be chosen to suit the application. Single-pass applications require testing using single-pass interferometers.

NOTE Modern interferometers use laser sources for considering the setting up of the interferometric test but it causes severe problems if a double-pass arrangement is chosen in reflected optical radiation, when Fizeau or Twyman-Green interferometers are used. All dielectric boundaries between lenses contribute to spurious fringe patterns.

Arrangements using transmitted optical radiation are less affected by spurious fringes than reflection type interferometers. It is preferable to use interferometers of the Mach-Zehnder or lateral shearing type or Shack-Hartmann arrangements in transmitted optical radiation. For the measurement of wave aberrations a single-pass geometry in transmitted optical radiation will therefore be the first choice for this aim.

## 7 Measurement arrangement

### 7.1 Measurement arrangement for single microlenses

Interferometers or wavefront detectors shall be used to measure the transmitted wavefront of the microlens under test. Single-path interferometers such as Mach-Zehnder, lateral shearing or double-pass interferometers such as Fizeau, Twyman-Green, and Shack-Hartmann wavefront detectors can be used for testing as shown in Annexes B to D.

The requirements for the measurement shall be defined. Typical criteria for choosing a specific method are:

- required accuracy,
- required properties to be measured,
- flexibility of the measurement,
- costs,
- spot test on one lens or complete measurement.

For more details see ISO/TR 14999-2.

### 7.2 Measurement arrangement for microlens arrays

Interferometers or wavefront detectors shall be used to measure simultaneously whole arrays or parts of them in the transmitted radiation. Typical test arrangements are described in Annexes E and F.

NOTE While the test of single lenses selected out of an array will be done with spherical wave irradiation of the sample lens this is in general not possible with array tests. In this case, a plane wave irradiation is more suitable or special provisions using diffractive array wavefront shaping elements have to be used (see e.g. Reference [9]).

### 7.3 Geometrical alignment of the sample

Usually the microlens being tested and its coupling optics shall be set or adjusted into co-axial alignment with the wavefront measuring instruments. Optical alignment instruments and/or devices are commercially available for this purpose.

NOTE The sample is mounted on a stage such as an air-chuck, which has two or three directions of freedom for adjustment.

### 7.4 Preparation

The test equipment shall be maintained in a temperature-controlled environment and not exposed to vibration so as to obtain consistent results.

The optical surfaces to be tested shall be clean. Uncoated glass surfaces may be safely cleaned with alcohol and cotton wool. The cotton wool should be soaked in a very small amount of solvent before touching the surface and wiped only once across it before being discarded. This minimizes the chances of scratching the surface. Dust may be removed using a clean camel-hair brush or filtered compressed air.

Coated optical surfaces such as antireflection surfaces should be treated with great care and not cleaned unless absolutely necessary. They may be dusted using filtered compressed air.

Guidance should be sought on the correct use of solvents, cotton wool or other wiping materials.

## 8 Procedure

Measurement requirements and typical methods for measuring the wavefront aberration of individual lenses are described in the Annexes A to D.

Examples for measurements of microlens array wavefront aberrations are described in the Annexes E and F.

## 9 Evaluation

The wavefront aberration can be calculated from the interferogram (see References [8] and [12]) or from other wavefront measuring systems described in Annexes A to F. From the wavefront aberrations of spherical lenses with circular apertures primary Zernike coefficients can be derived with a prescribed software aperture.

NOTE 1 Typical Zernike coefficients are:

- spherical aberration,
- astigmatism,
- coma.

NOTE 2 For other lens aperture shapes (such as rectangular), see ISO/TR 14999-2.

The measured wavefront aberrations of samples shall be evaluated and quoted, for example, as peak-to-valley or root-mean-square values.

Care should be taken to interpret peak-to-valley values because they are influenced by spurious values. It is recommended to use 6 times the rms figure instead.

## 10 Accuracy

The wavefront aberrations of a sample are measured by a wavefront test system, which may introduce some aberration of its own. The accuracy of measurement can be improved by subtracting the system aberrations.



## 11 Test report

The test results shall be recorded and shall include the following information if applicable:

- a) general information:
  - 1) test has been performed in accordance with ISO 14880-2:2005;
  - 2) date of test;
  - 3) name and address of test organization;
  - 4) name of individual performing the test;
- b) information concerning the tested lens:
  - 1) lens type;
  - 2) manufacturer;
  - 3) manufacturer's model;
  - 4) serial number;
- c) test conditions (environmental conditions):
  - 1) temperature;
  - 2) relative humidity;
- d) information concerning testing and evaluation:
  - 1) test method used;
  - 2) optical system used;
  - 3) irradiation:
    - i) source type,
    - ii) wavelength,
    - iii) half-width of optical radiation spectrum,
    - iv) polarization status,
    - v) irradiance angle,
    - vi) spot size;
  - 4) detector;
  - 5) aperture;
- e) test results:
  - 1) peak-to-valley value of wavefront aberration  $\Phi_{p-v}$ ;
  - 2) root-mean-square value of wavefront aberration  $\Phi_{rms}$ ;
  - 3) Zernike polynomials or other polynomial coefficients.

## Annex A (normative)

### Measurement requirements for test methods for microlenses

The test for wave aberrations of microlenses shall be performed in transmitted optical radiation and in a single-pass arrangement, an interferometer like a Mach-Zehnder interferometer, a lateral shearing interferometer, or a Shack-Hartmann wavefront sensor. A single-pass test device is required for sharp imaging of the lens aperture onto the detector or sensor array and the strong disturbances due to spurious reflections in a double-pass arrangement as in a Fizeau or a Twyman-Green interferometer. In a double-pass geometry the lens under test will deliver two images of the lens aperture one being out of focus causing diffraction effects like edge ringing in the rim region of the lens under test. Such effects can be avoided by using a single-pass arrangement because all reflections from lens surfaces in the auxiliary optical system in the forward direction are negligible being reflected twice at antireflection coated surfaces. In addition, due to sharp imaging of the lens aperture, there are no ambiguities concerning the definition of the wave aberrations.

The test device shall not introduce aberrations of its own. In a Mach-Zehnder geometry, where the test sample is put into one arm of the interferometer and the reference arm delivers a plane wavefront, the beam splitting/combining optical elements are traversed by plane waves only. Spherical waves would produce spherical aberration or worse aberrations for non-symmetric beam splitters. Similar requirements are also valid for a Shack-Hartmann sensor although no beam splitters are used in this case.

In the case of lateral shearing interferometers, it is necessary to keep the design of the shearing device symmetric and as simple as possible (see for example the shearing interferometer based on two-phase gratings in a series arrangement [array tests]) in order to avoid additional measuring errors.

Since the microlens diameters cover a range between 10  $\mu\text{m}$  and a few millimetres, it is necessary to provide a means for changing the magnification by at least two orders of magnitude in order to fill the aperture of the array photo-detector, typically a CCD-matrix, to obtain sufficient lateral resolution so that also strongly deformed wavefronts can be tested without the violation of the sampling theorem. Due to the great span of magnifications in combination with the requirement of a plane wave interferometer, the imaging microscope shall be incorporated into the test arm for high magnification ratios commonly obtained with short working distances of the imaging microscope objective. If the imaging objective is to be used outside the interferometer structure, special objective designs are necessary to enable high magnification ratios in combination with long working distances. Two alternative solutions will be discussed in some detail to demonstrate Mach-Zehnder interferometers for the test of wave aberrations. The imaging microscope will preferably be of the telescopic type in order to maintain in the test arm plane waves at the beam combiner.

The change of magnification requires special measures to adapt the splitting ratio between the two arms of the interferometer to obtain sufficient contrast of the interference fringes. The best choice for such an aim is a polarizing splitting unit consisting of a polarizing beam splitter in combination with two quarter-wave plates (QWP), one in each arm of the interferometer and a half-wave plate (HWP) in front of the splitting unit for rotating the polarization vector.

It is also necessary to provide means for varying the mean intensity independently from the splitting ratio because the photo-detector might be driven into the state of saturation producing incorrect measuring results due to non-linear signal distortions.

The measurement of wave aberrations requires the irradiation of the test lens from the rear by a spherical wavefront produced by a high-quality microscope objective having a numerical aperture exceeding that of the lens under test. This objective shall have a Strehl definition above 95 % to ensure a simple test philosophy making calibrations obsolete in most test situations.

For the characterization of small numerical aperture lenses, it is advisable also to provide plane wave irradiation of the sample. Plane wave irradiation enables the measurement of the focal length of the lens. Plane wave irradiation can be used for the determination of the focal length for high aperture lenses in the

central resolved interference fringe field. For this purpose, the software has to provide for a central data selection mask of known lateral dimensions. It is possible to determine the effective focal length using the phase excursion  $\phi$  within the selected field of interest:

$$\frac{1}{f} = \frac{\phi\lambda}{\pi\rho_{\text{mask}}^2}$$

A simple calibration of the scaling factor with the help of a commercial object micrometer delivers the absolute diameter  $2\rho_{\text{mask}}$  in  $\mu\text{m}$ .

In Annexes B and C, two alternative solutions for interferometric approaches are given which fulfil the **main part or all** of the above defined measuring requirements.

## Annex B (normative)

### Microlens test Methods 1 and 2 using Mach-Zehnder interferometer systems

#### B.1 Measurement arrangement and test equipment

Methods 1 and 2 describe Mach-Zehnder interferometer systems, which use plane waves in most parts and deviates from plane waves only to measure and to image the wavefront aberrations of the microlens on the array detector by means of a specially designed micro-objective outside the interferometer structure having a very long working distance.

#### B.2 Measurement

##### B.2.1 Method 1

Elements are aligned co-axially. These elements include the radiation source, the beam expander, the aperture stop, the illuminating microscope objective, a standard lens or a microlens under test, Mirrors 1 to 4, an imaging lens, and an image sensor. The standard lens and the microlens shall be adjusted in such a manner as to guarantee a minimum of aberrations.

Figure B.1 shows a phase shifting interferometer based on a Mach-Zehnder geometry using Mirrors 1 to 4. A parallel beam emitted from a laser source is expanded by a beam expander and is stopped down by means of an aperture stop in front of the interferometer. The beam is then divided into two beams with the help of a semitransparent Mirror 1. The beam of the test arm of the interferometer impinges on a beam shaping objective providing a spherical wavefront for the irradiation of the microlens under test or an artefact lens being free from aberrations but having the same size. The microlens or artefact lens are positioned confocally producing a nearly plane wavefront in the exit pupil of the lens under test. This wavefront is superimposed with the plane reference wave resulting in an interference pattern. An imaging objective in the exit of the interferometer images the lens aperture sharply onto the photo-detector with a suitable scaling factor to exploit a large part of the photosensitive area of the array detector providing sufficient data samples for the characterization of the lens aberrations. The physical aperture stop in front of the interferometer shall be positioned on the optical axis at a distance from the illuminating objective of the test arm so that a sharp image of this stop coincides with the lens aperture under test.

The evaluation of the wave aberrations is made by reading several phase shifted interference patterns into the on-line computer memory and an *a posteriori* evaluation.

In a first step, the wavefront aberrations of a standard lens together with the aberrations caused by the interferometer are measured and shall be denoted as  $\Phi_0$ .

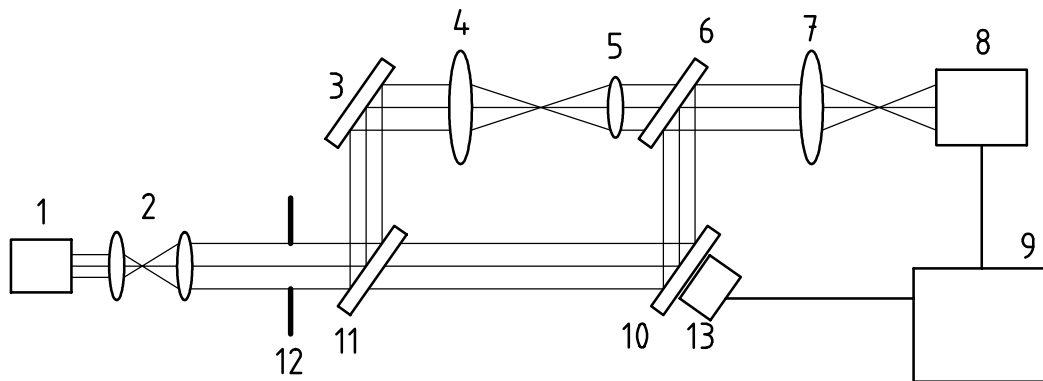
In a second step, the microlens to be tested is placed in the interferometer. The wavefront aberrations of the microlens under test shall be denoted as  $\Phi$ . These aberrations result from the difference of the data  $\Phi_1$  minus the wave aberrations  $\Phi_0$  measured in conjunction with the standard lens

$$\Phi = \Phi_1 - \Phi_0$$

It is important to use an illuminating microscope objective with an effective NA larger than that of the microlens being tested.

NOTE 1 In the configurations shown in Figure B.1, it is possible to put an aperture at the pupil position of the second standard lens or that of the microlens under test, or nearby.

NOTE 2 The aperture defines the diameter of the test area of the second standard lens or the microlens under test. It is also possible to define the test area of the second standard lens and of the microlens under test by placing the aperture at the image sensor position or by generating the aperture using software.



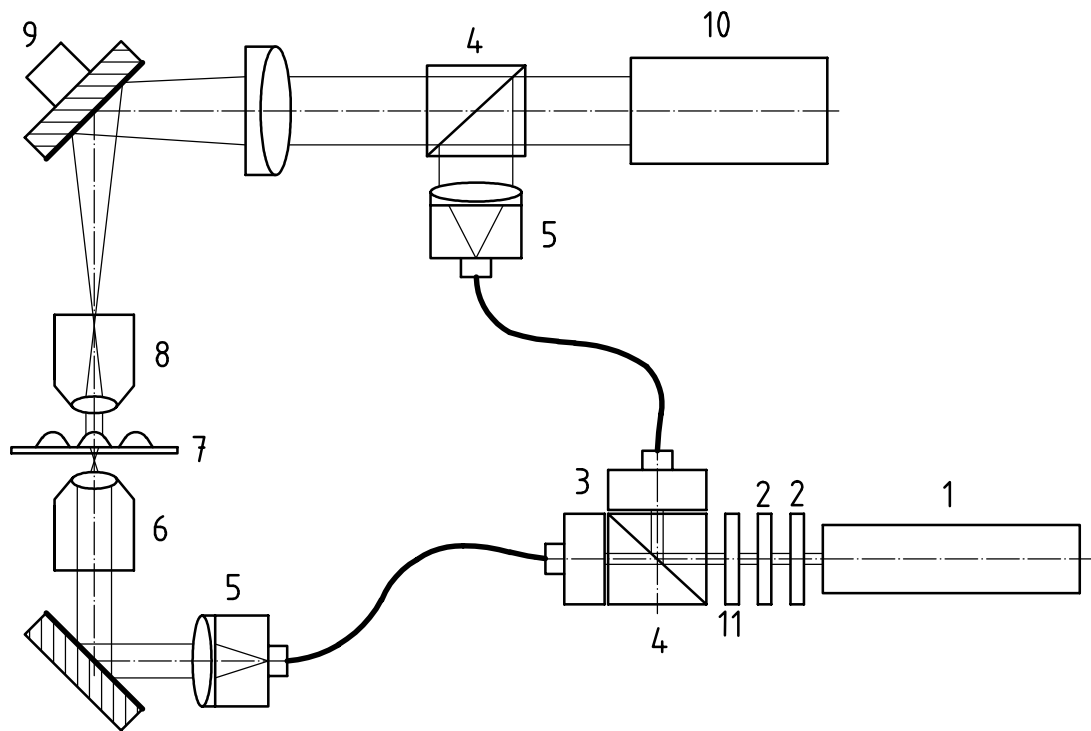
**Key**

- 1 light source
- 2 beam expander
- 3 Mirror 2
- 4 1st standard lens
- 5 2nd standard lens or microlens under test
- 6 Mirror 4
- 7 imaging lens
- 8 image sensor
- 9 image processor
- 10 Mirror 3
- 11 Mirror 1
- 12 aperture stop
- 13 piezoelectric transducer (PZT)

**Figure B.1 — Phase shift interferometer based on Mach-Zehnder interferometer**

**B.2.2 Method 2**

Method 2 describes an alternative and more flexible solution of an interferometer based on a strongly modified Mach-Zehnder geometry using flexible single mode fibres in both arms of the interferometer [18].



**Key**

- 1 laser 633 nm/polarized
- 2 polarizer
- 3 fibre coupler
- 4 beam splitter
- 5 beam expander
- 6 illumination micro objective 20×
- 7 microlens under test
- 8 imaging micro objective 5×; 10×; 20×; 50×
- 9 mirror mounted on a piezoelectric transducer
- 10 charge-coupled device (CCD)
- 11 half-wave plate (HWP)

**Figure B.2 — Mach-Zehnder interferometer based on a beam splitting unit using single mode polarization maintaining fibres and an imaging microscope incorporated into the test arm of the interferometer**

For the irradiation of the interferometer typically a He-Ne-Laser is used (see Figure B.2). The polarization-based beam-splitting unit allows for the independent adjustment of the mean intensity by rotating a polarizer and of the splitting ratio between the object and the reference beam by turning a HWP in front of a polarizing beam-splitting cube. The polarized beams are fed to single mode fibres and each output is expanded to a plane wave. The reference wave is combined with the object wave with the help of a non-polarizing beam splitter. The polarization of the reference beam is matched with that of the object beam by rotating the end of the fibre accordingly. For the irradiation of the lens to be tested there are two alternatives:

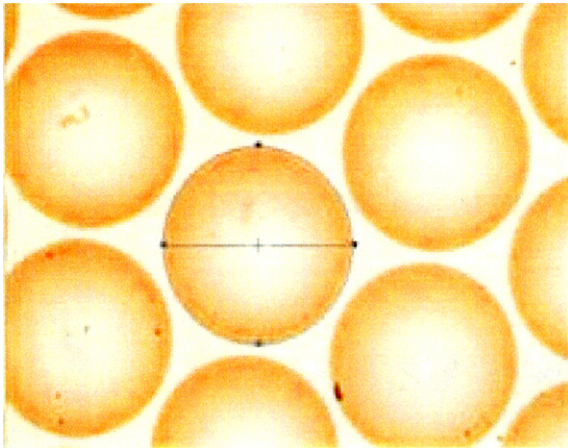
- a) spherical wave irradiation for the determination of wave aberrations;
- b) plane wave irradiation realized by removing the micro-objective in front of the lens to be tested.

In the first case a high-quality microscope objective with a sufficient working distance is used to transform the incoming plane wave into an ideal spherical wave which enables the measurement of the wave aberrations for  $\infty/f$ -conjugates. The second type of irradiation will be chosen for the measurement of weak lenses and in general for phase objects giving the whole phase retardation due to the test sample. Also in the plane wave irradiation configuration there is the possibility for the determination of the effective focal length from the measured phase distribution in a reduced field around the vertex of the lens under test.

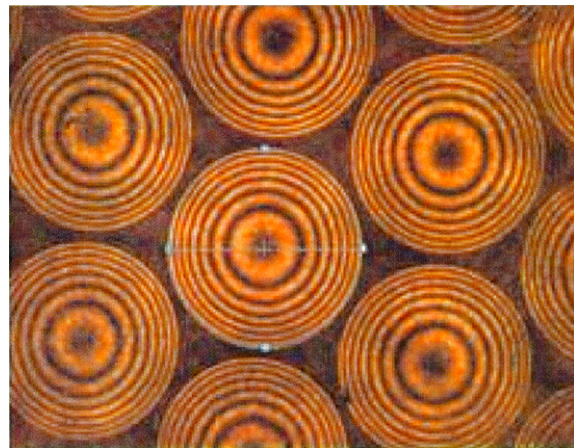
The lens array is placed on a  $xy$ -stage. The microlens under test is sharply imaged onto the photo-detector array with the help of a microscope consisting of a microscope objective and a tubus lens forming an afocal setup. The detector array is positioned in the focal plane of the tubus lens. Since the set of microscope objectives given in Figure B.2 is designed for the same working distance, it is necessary to take special measures to avoid systematic errors when changing the magnification. In order to keep the imaging afocal, if the microscope objective is changed the tubus lens together with the beam combining group and the detector are shifted axially as a unit maintaining plane wave irradiation for the beam combining cube. In this way the danger of aberrations caused by improper adjustments is minimized.

The interferometer shown in Figure B.2 is equipped with a polarizing beam-splitting unit allowing for the independent variation of the splitting ratio and the mean intensity as it was required above. Due to the fibre coupling between the beam splitter group and the rest of the interferometer the interferometer could be built into a commercial microscope having the advantage of all adjustment means of such instruments.

Figures B.3 to B.5 show the field of view for the different adjustments possible in the case of the interferometer shown in Figure B.2. A measuring result for the wave aberrations of a spherical microlens is given in Figure B.6.

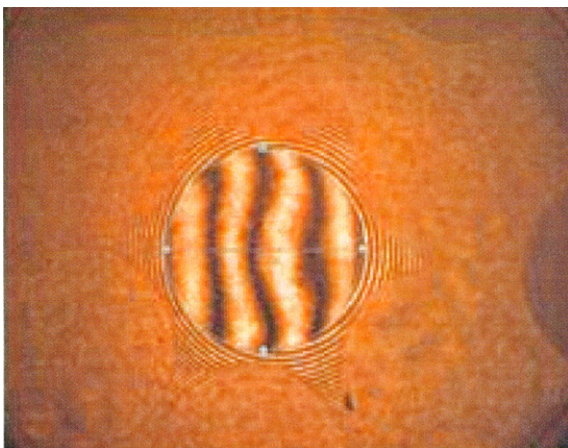


**Figure B.3 — White light irradiation for positioning of mask**



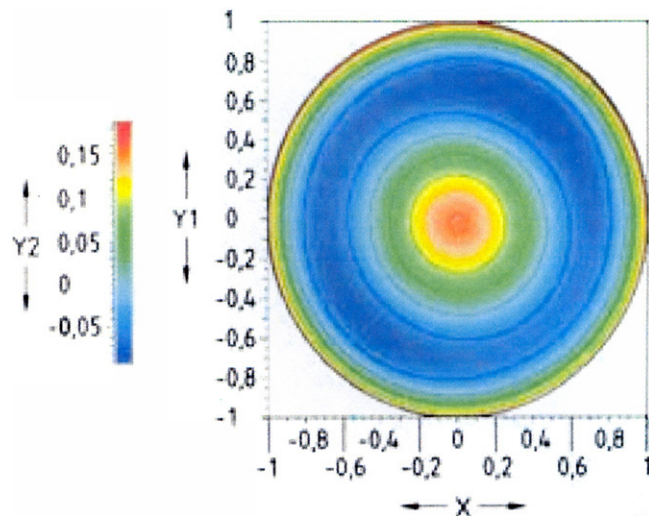
The lens is selected with a mask indicating the field of interest.

**Figure B.4 — Plane wave irradiation of the lens array plane**



The interference fringes give a clear indication of spherical aberration.

**Figure B.5 — Field of view with spherical wave irradiation**



**Key**

- X normalized radius (x-direction)
- Y1 normalized radius (y-direction)
- Y2 phase/lambda

**Figure B.6 — Wave aberrations given as Zernike fit**



## Annex C (normative)

### Microlens test Methods 3 and 4 using a lateral shearing interferometer system

#### C.1 Measurement arrangement and test equipment

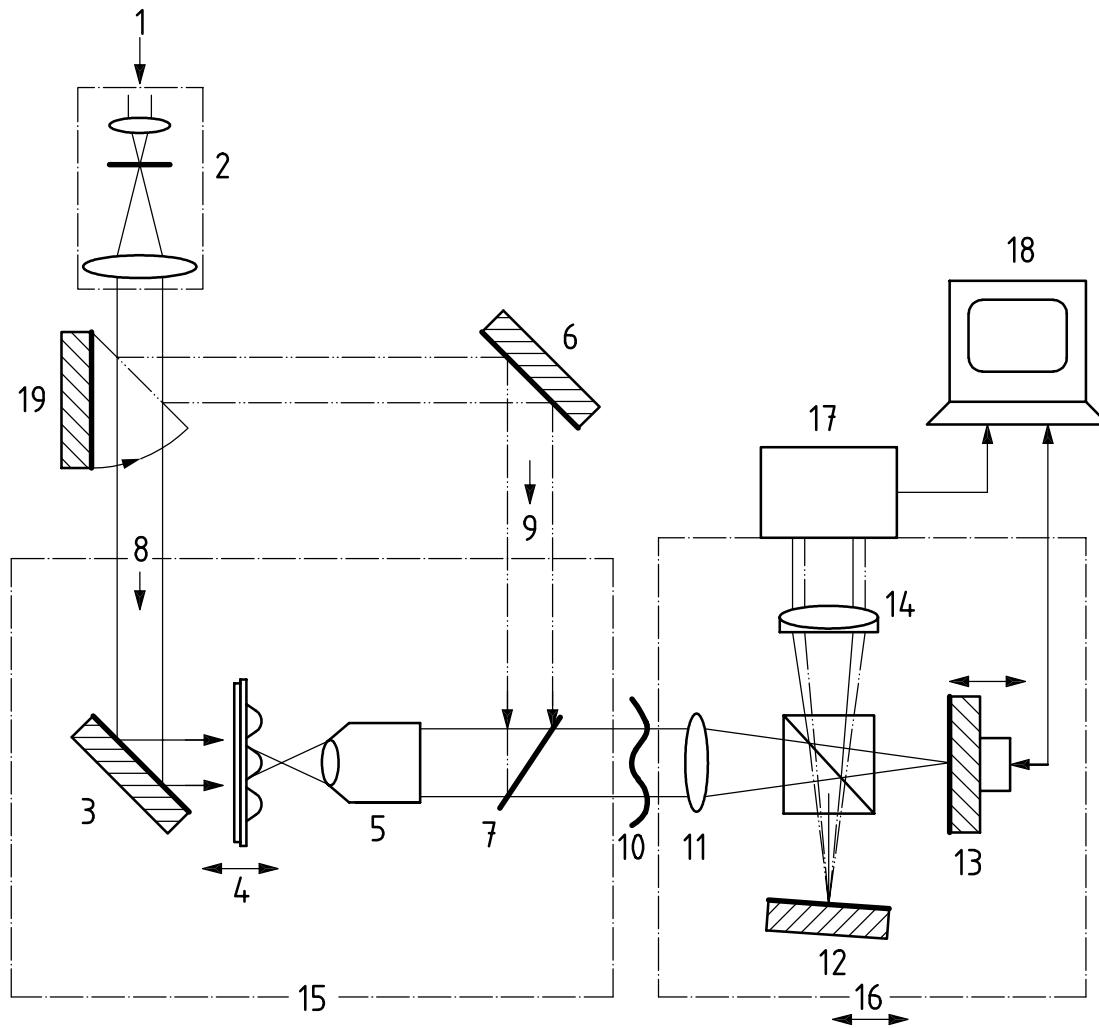
Method 3 <sup>[19]</sup> uses a lateral shearing interferometer system which measures wavefront aberrations of microlenses via the measurement of the partial derivatives of the wavefront in two orthogonal directions and a posteriori integration of the two data fields resulting in the wave aberrations.

#### C.2 Measurement

##### C.2.1 Method 3

Figure C.1 shows a lateral shearing interferometer. With this configuration, the beam expander expands a parallel beam emitted from the source of optical radiation. The parallel beam is then transmitted to the microlens under test which transforms the spherical wavefront emerging from the microlens into a plane wavefront by means of a high-quality microscope objective having a sufficient numerical aperture. The outgoing nearly plane wavefront carries the wave aberrations of the lens under test. An auxiliary objective focuses the wavefront onto the end mirrors of a Michelson interferometer. By tilting one (or both in opposite directions) of the mirrors the emerging wavefronts from an identical auxiliary objective are laterally sheared to each other.

If the axial distances of the components of the whole set-up are properly chosen an image of the lens aperture is sharp on the detecting array providing a shearing interferogram for instance in the  $x$ -direction. Tilting the mirror of the Michelson around the orthogonal axis an interferogram in the  $y$ -direction is formed. The phase distributions are measured by means of phase shifting techniques. The necessary phase shifts are produced by moving one of the mirrors axially with the help of a piezoelectric transducer (PZT) device. The integration of the two shear images enables the determination of the wave aberrations. The same set-up has also a reflected ray opportunity to measure the position of the vertex of the microlens enabling the determination of the effective focal length by moving the micro-objective between the cat's eye and the focus position with a stage having a length measuring facility.



**Key**

- |                                 |  |
|---------------------------------|--|
| 1 laser                         | 11 auxiliary lens                              |
| 2 beam expander                 | 12 Mirror 1, tiltable                          |
| 3 mirror                        | 13 Mirror 2, on piezoelectric transducer (PZT) |
| 4 microlenses under test        | 14 sheared apertures                           |
| 5 microscope objective 20×0,65  | 15 illumination setup                          |
| 6 mirror                        | 16 shearing setup                              |
| 7 beam splitter                 | 17 charge-coupled device (CCD)                 |
| 8 transmitted optical radiation | 18 PC  |
| 9 reflected optical radiation   | 19 tiltable mirror                             |
| 10 aberrant plane wave          |  |

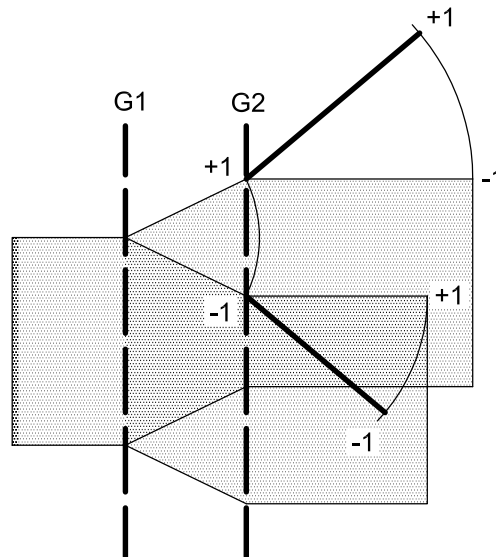
NOTE The incoming wavefront is focused on the mirror with the help of a well corrected small numerical aperture objective. The impact of the beam splitting cube onto the wavefront aberrations is taken into account in the design of the auxiliary objective.

**Figure C.1 — Lateral shearing interferometer based on a Michelson-setup where the lateral shear is produced by tilting one of the mirrors**

### C.2.2 Method 4

NOTE See Reference [20] for details.

Method 4 relies on the use of two diffractive beam splitters (see Figure C.2 for the physical principle of the diffraction based shearing device) for providing the shear. In this case, the shear is directly applied to plane waves coming from the combination of the microlens plus a compensating microscope objective (see Figure C.3 for a set-up enabling the measurement of the wave aberrations of a microlens).

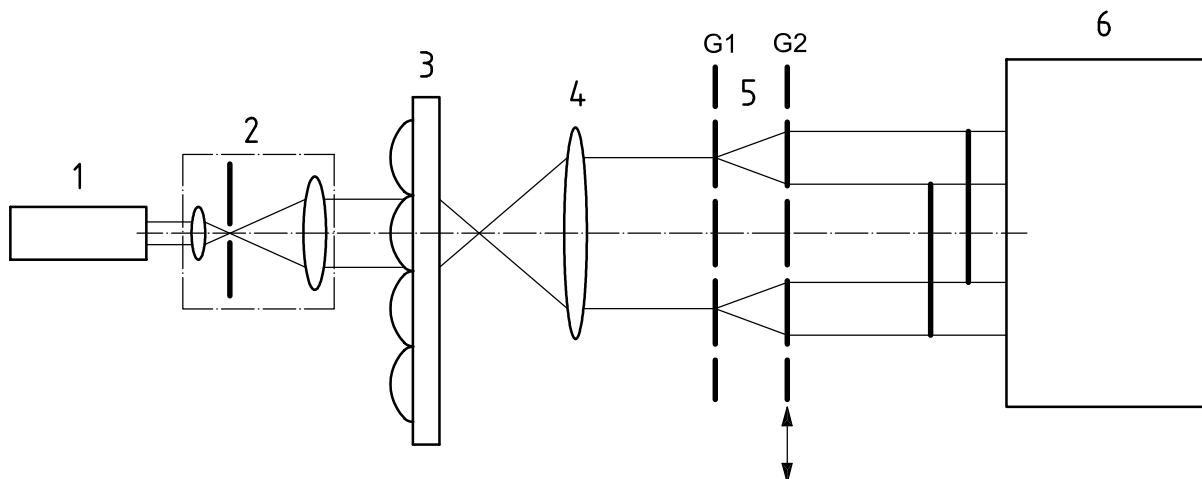


**Key**

- G1 Grating 1
- G2 Grating 2
- +1, -1 order of diffracted beam

NOTE The binary phase grooves provide a phase shift of  $\pi$ , enabling a suppression of the zero diffraction order.

**Figure C.2 — Shearing interferometer on the basis of a series arrangement of two Ronchi-phase gratings**



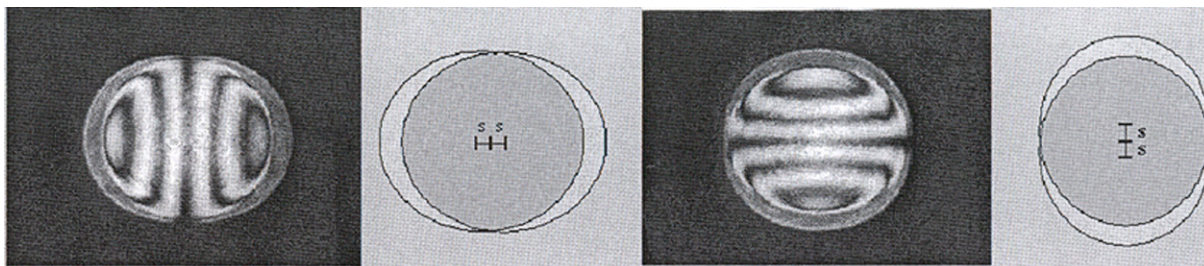
**Key**

- 1 laser
- 2 beam expander
- 3 microlens array under test
- 4 microscope objective
- 5 shearing interferometer
- 6 charge-coupled device (CCD)
- G1 Grating 1
- G2 Grating 2

**Figure C.3 — Shearing interferometer set-up for testing microlenses with respect to wave aberrations on the basis of a diffractive shearing unit being symmetric and free from aberration contributing elements**

Shearing interferometers provide the partial derivatives (or more exactly, the difference of wavefront aberrations between laterally sheared copies of the wavefront under test). Therefore, it is necessary to measure the derivatives in two dimensions (see Figure C.4 as an example) in order to be able to calculate the wave aberrations a posteriori by fitting suitable polynomials to the data. For this integration, it is necessary to know the lateral shear amount and the lateral metric in order to obtain reliable data for the wavefront aberrations. The diffractive shearing set-up has some very essential advantages:

- a) it provides a symmetric shear around the optical axis;
- b) it is extremely stable and easy to integrate into an optical set-up;
- c) it can be rotated as a whole by 90° to obtain the two orthogonal derivatives;
- d) the shear can be adjusted simply by varying the distance of the gratings;
- e) the phase can very easily be shifted by a translation of one of the gratings in relation to the other perpendicular to the grooves of the gratings;
- f) due to the simple design with two plane parallel glass plates having binary relief structures on one side, the contribution of the interferometer components to the aberrations can be kept below 1/20 of a wavelength using standard manufacturing methods for the phase gratings.



**Key**

$s$  lateral shear

NOTE Since the shearing unit is rather compact and common path-type the two orthogonal shears can be adjusted by rotating the grating combination through  $90^\circ$ .

**Figure C.4 — Shearing interferograms produced with the help of a diffractive shearing interferometer at a wavelength of 1 320 nm in  $x$ - and  $y$ -direction**

## Annex D (normative)

### MicroLens test Method 5 using a Shack-Hartmann sensor system

#### D.1 Measurement arrangement and test equipment

Wavefront aberrations of a microlens can also be measured using a Shack-Hartmann wavefront sensor system.

The Hartmann principle is based on a subdivision of the beam into a number of beamlets. This is either accomplished by an opaque screen with pinholes placed on a regular grid (Hartmann sensor), or by a lenslet or micro-lens array (Shack-Hartmann sensor), resulting in an average wavefront gradient sampling and a better radiation collecting efficiency. The power (energy) density distribution behind the array is recorded by a position sensitive detector, most commonly a CCD sensor or an array of quadrant detectors (quadcells). The detector signals can be acquired by a computerized data acquisition and analysis system. (See also ISO 15367-2.)

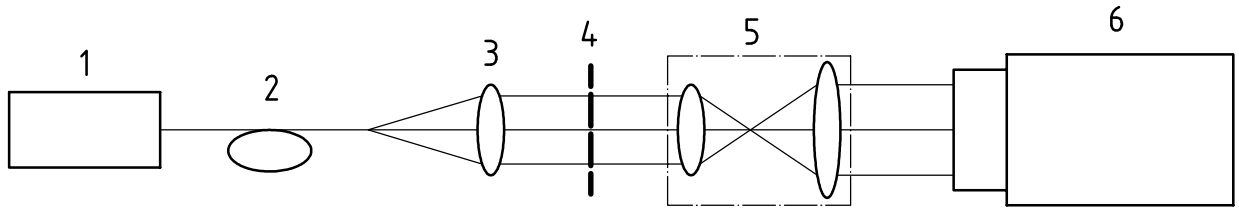
#### D.2 Measurement

Figure D.1 shows the layout used to measure the wavefront aberrations with a Shack-Hartmann wavefront sensor. The elements are aligned co-axially. These elements include an optical radiation source, fibre, collimating lenses, microlens being tested, beam expander, and a wavefront sensor along with an appropriate image processor (not shown).

First a reference file is created with the wavefront sensor using the layout in Figure D.1. The output of optical radiation from a fibre is collimated and sent through a microscope the output of which is impinging on a wavefront sensor. This reference contains information on the combined effect of the optics used for the beam expander. The aberrations of the reference wavefront will be subtracted from the subsequent microlens measurements.

Next, there are two possibilities for measuring the actual microlens depending on the power of the microlens. For a "slower" microlens (where the NA of the microlens is less than the NA of the fibre), the layout in Figure D.2 can be used to measure the aberrations. In this case, a microlens is placed at the imaging plane just preceding the beam expander and the position of the fibre is adjusted to collimate the beam through the microlens. The aberrations of the microlens are automatically measured with respect to the reference measurement taken with the set-up in Figure D.1 (the aberrations of the beam expander optics are subtracted out in the reference file).

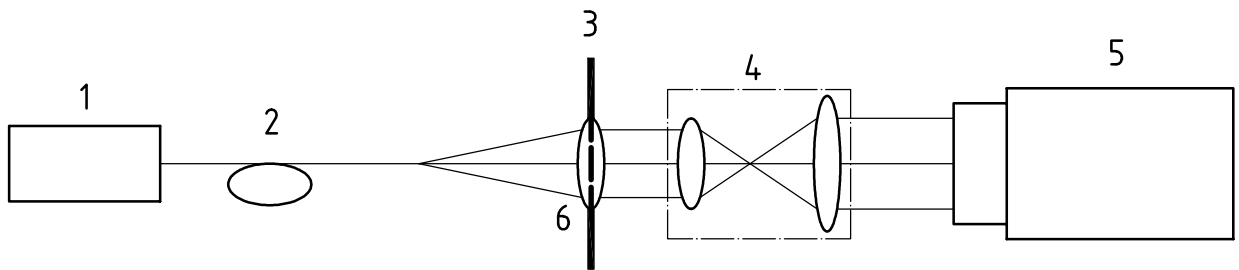
For a "faster" microlens (where the NA of the microlens is larger than the NA of the fibre), the layout in Figure D.3 is used. In this case, a slower lens is used to collimate optical radiation from the fibre through a fast refocusing lens (at least as fast as the microlens being tested), which is then incident upon the microlens to be tested. Again the aberrations of the microlens are measured with respect to the reference file.



**Key**

- |                               |                         |
|-------------------------------|-------------------------|
| 1 source of optical radiation | 4 imaging plane         |
| 2 fibre                       | 5 beam expander         |
| 3 collimating lens            | 6 Shack-Hartmann sensor |

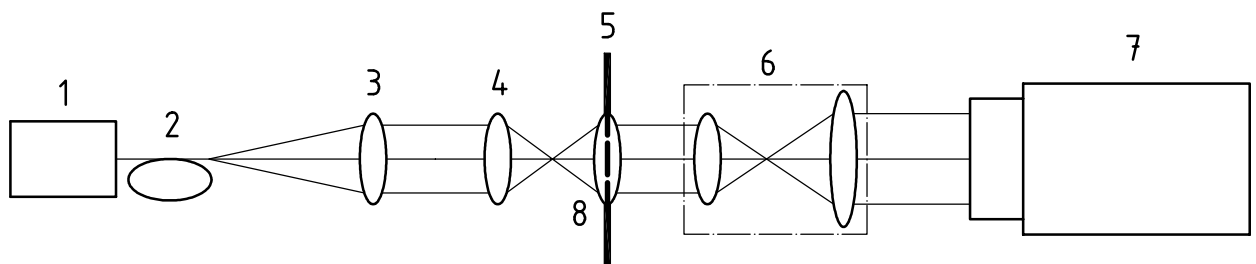
**Figure D.1 — Layout for reference measurement**



**Key**

- |                               |                                 |
|-------------------------------|---------------------------------|
| 1 source of optical radiation | 4 beam expander                 |
| 2 fibre                       | 5 Shack-Hartmann sensor         |
| 3 aperture                    | 6 slower microlens to be tested |

**Figure D.2 — Layout for measurement of a "slow" microlens**



**Key**

- |                               |                               |
|-------------------------------|-------------------------------|
| 1 source of optical radiation | 5 aperture                    |
| 2 fibre                       | 6 beam expander               |
| 3 collimating lens            | 7 Shack-Hartmann sensor       |
| 4 refocusing lens             | 8 fast microlens to be tested |

**Figure D.3 — Layout for measurement of a "fast" microlens**

## Annex E (normative)

### Microlens array test Method 1 using a Twyman-Green interferometer system

#### E.1 Measurement arrangement and test equipment

Array test Method 1 uses a Twyman-Green interferometer system to measure the wavefront aberrations of a microlens array.

#### E.2 Measurement

Figure E.1 shows a Twyman-Green interferometer for microlens array wavefront measurement. A parallel beam from the optical radiation source is expanded by the beam expander and passes to a polarization beam splitter via a half-wave plate. The beam is divided into two beams at the polarization beam splitter. The p-polarized beam is reflected at the first reference plane and combined with a piezoelectric transducer (PZT) after passing through a quarter-wave plate. It is then converted to the s-polarized beam after the quarter-wave plate and after reflecting off the polarization beam splitter.

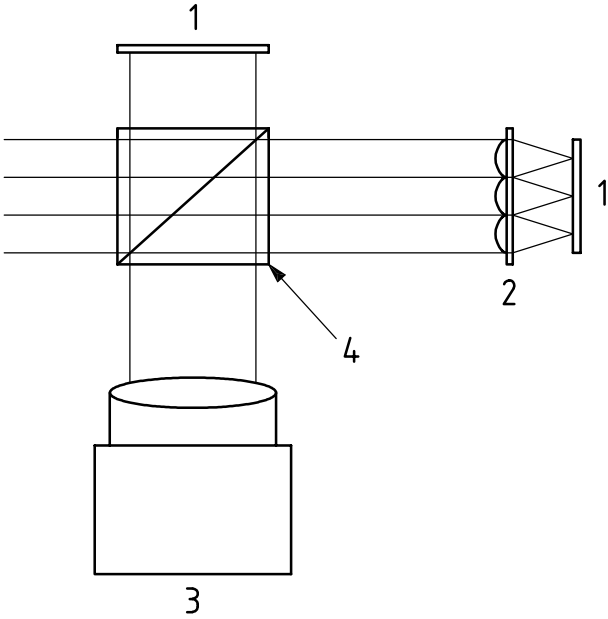
The s-polarization beam reflected at the polarization beam splitter is impinging on the microlens array under test after passing through another quarter-wave plate. The transmitted beam through the microlens array under test is reflected at a plane mirror, and passes on its way back again the microlens array and is converted into a p-polarized beam via the quarter-wave plate. It is then superimposed with the reference wavefront after passing through the polarization beam splitter. The image of the interference fringe pattern of the two superimposed wavefronts is formed on an image sensor by an imaging lens. Phase shifts are accomplished by applying a voltage to a piezoelectric transducer (PZT) attached to a reference mirror.

As a result the even wavefront aberrations of each microlens being tested combined with the aberrations of the interferometer including the reference plane errors are obtained. The method for subtracting system aberrations from the microlens array data is similar to that described in the previous section.

Elements are aligned co-axially. These elements include the optical radiation source, beam expander, aperture stop, first- and second- standard lenses, microlens array under test, mirrors, imaging lens, and an image sensor.

With the arrangement of Figure E.1, only the even part of the wavefront aberrations can be measured which means that spherical aberration is measured correctly but not, for example, coma. The reason for this restriction is the inversion of the optical radiation path after the reflection of the focused beams at a plane mirror.





**Key**

- 1 mirror
- 2 microlens array under test
- 3 detector
- 4 beam splitter

**Figure E.1 — Twyman-Green interferometer for microlens array wavefront measurement**

## Annex F (normative)

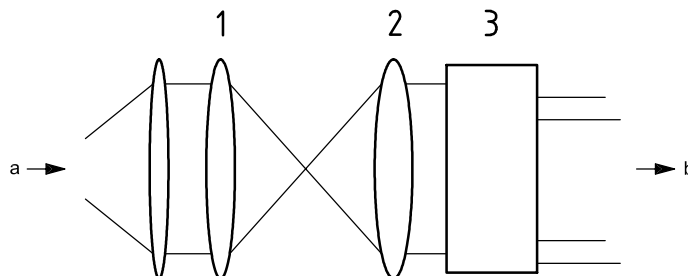
### Measurement of uniformity of microlens array determined by test Method 2

#### F.1 Measuring arrangement and test equipment

Lens arrays can be measured for uniformity of the array and with the help of an array of computer-generated holograms (CGHs) or diffractive optical elements (DOEs) representing an ideal spherical wave function with respect to a parallel measurement of wave aberrations. Shearing interferometers as well as single path interferometers of the Mach-Zehnder type are suitable test interferometers.

#### F.2 Measurement of uniformity

Lateral shearing interferometers can be used to retrieve information on the wave aberrations of a lens array (see Figure F.1) provided the diameter of the single lenses is smaller than the pitch of the array which is necessary to allow for unique shearing interferograms of each lens of the array. For densely packed arrays, there is the possibility to shear by one pitch and compare in this way neighbouring lenses of the array by measuring the difference of the wave aberrations of next neighbours. Therefore, such a test will be only a uniformity test (see Figure F.2).

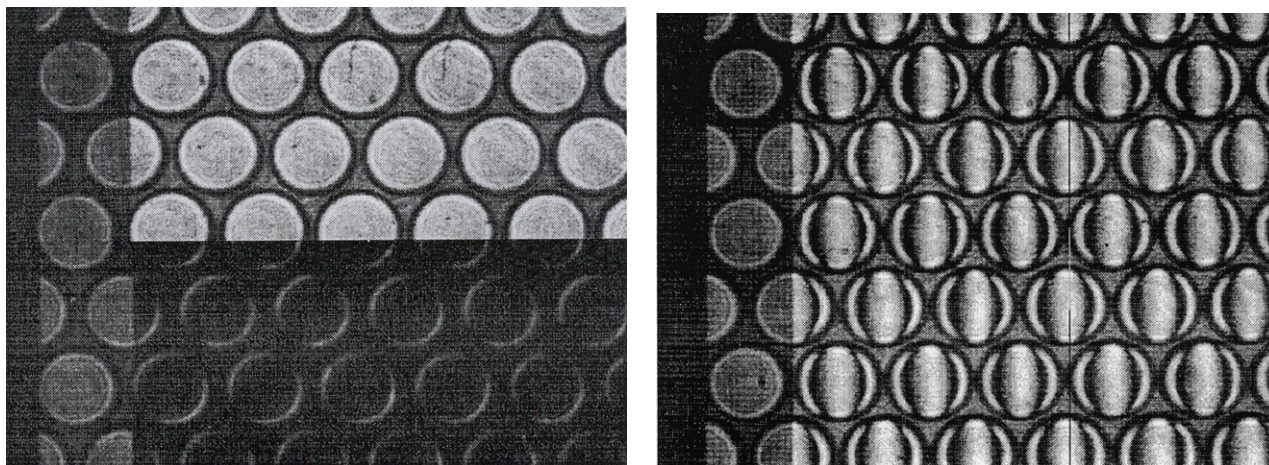


#### Key

- 1 auxiliary optics
- 2 microlens array under test
- 3 lateral shear interferometer
- a From laser.
- b To detector.

Figure F.1 — Test arrangement using a lateral shearing interferometer

Care has to be taken with the selection of a suitable shearing interferometer because otherwise the test is affected by wavefront aberrations resulting from imperfections of the interferometer. In Figure F.3, a shearing interferometer solution is shown relying on two phase gratings in a series arrangement where the phase gratings are of the Ronchi type, meaning that the even orders are missing and the zero order is suppressed by choosing a suitable etching depth of the binary surface corrugation. The shear amount can be varied through the distance of the gratings and a lateral shift perpendicular to the grating grooves provides a phase shift in the interferograms mandatory for phase shift evaluations. Since the interferometer consists of only two surface relief gratings it is possible to obtain an instrument with aberrations below the  $\lambda/20$ -level.

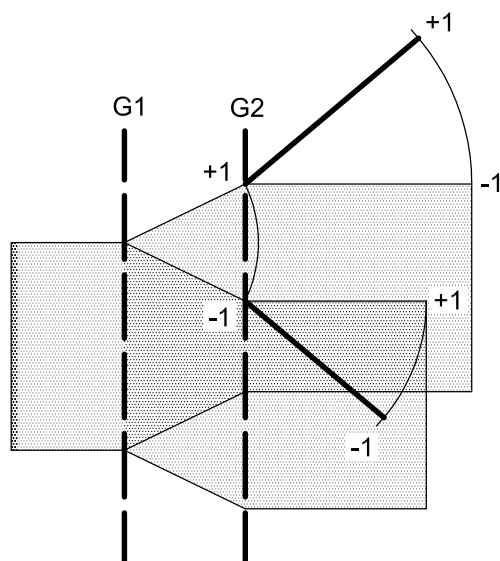


a) Exact coincidence

b) Shear slightly smaller than a) showing a small contribution of spherical aberration

NOTE On the left rim of the interferograms the shear by one lens pitch can be inferred.

Figure F.2 — Examples of a uniformity test by shearing by one lens pitch



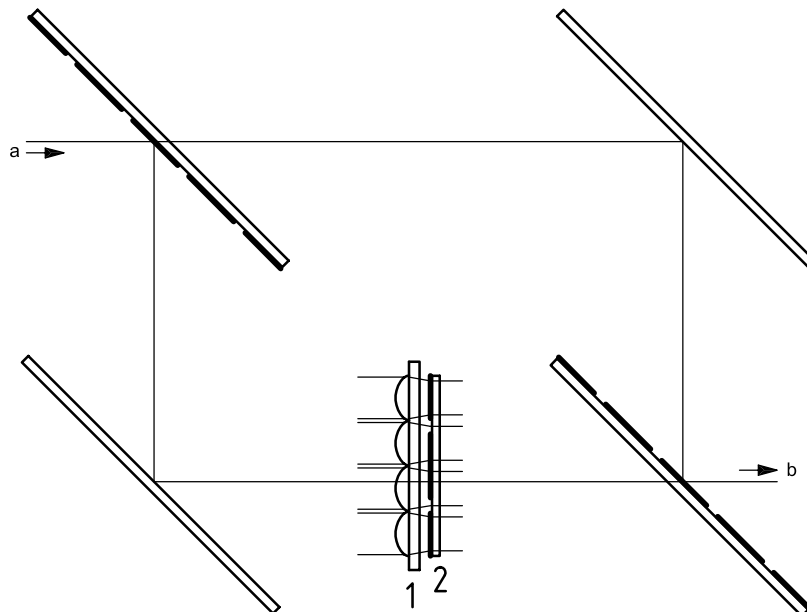
**Key**

- G1 Grating 1
- G2 Grating 2
- +1, -1 order of diffracted beam

Figure F.3 — Lateral shearing interferometer on the basis of two phase gratings of the Ronchi type in series arrangement providing a high degree of freedom from device errors because of the highly symmetric optical radiation path

### F.3 Simultaneous measurement of the wave aberrations of a microlens array

Wave aberration measurement assumes the irradiation of the lens under test with an ideal spherical wave or the compensation of the spherical wavefront curvature by a null lens or a null component like a computer-generated hologram (CGH). Since the array shall be tested as a whole the pitch of the lens array and the null CGH array shall match. Figure F.4 shows an arrangement for a single-pass test in transmitted optical radiation within a Mach-Zehnder structure. Here, the diffractive null compensates the spherical wave front curvature resulting in the wave aberrations of the lenses of the array. For the evaluation of array interferograms a special software has to be written to allow for the simultaneous evaluation of the wave aberrations of the lenses within the array.



#### Key

- 1 lens array under test
- 2 computer-generated hologram (CGH)-array

The pitch of the two arrays has to be the same.

- a From laser.
- b To detector.

**Figure F.4 — Wavefront aberration measurement of a lens array using an array of computer-generated hologram (CGH)-compensators for the spherical part of the wavefront**

## Bibliography

- [1] ISO 10110-14, *Optics and optical instruments — Preparation of drawings for optical elements and systems — Part 14: Wavefront deformation tolerance*
- [2] ISO 15529, *Optics and optical instruments — Optical transfer function — Principles of measurement of modulation transfer function (MTF) of sampled imaging systems*
- [3] ISO 15367-2, *Lasers and laser-related equipment — Test methods for determination of the shape of a laser beam wavefront — Part 2: Shack-Hartmann sensors*
- [4] ISO/TR 14999-1, *Optics and photonics — Interferometric measurement of optical elements and optical systems — Part 1: Terms, definitions and fundamental relationships*
- [5] ISO/TR 14999-2, *Optics and photonics — Interferometric measurement of optical elements and optical systems — Part 2: Measurement and evaluation techniques*
- [6] ISO/TR 14999-3, *Optics and photonics — Interferometric measurement of optical elements and optical systems — Part 3: Calibration and validation of interferometric test equipment and measurements*
- [7] ISO/TR 14999-4, *Optics and photonics — Interferometric measurement of optical elements and optical systems — Part 4: Interpretation and evaluation of tolerances specified in ISO 10110*
- [8] HERZIG, H.P., (ed), *Micro-Optics: Elements, systems and applications*. Taylor & Francis Ltd, London, 1997
- [9] SCHWIDER, J., and SICKINGER, H., Array tests for microlenses. *Optik* **107**(1), 1997, pp. 26-34
- [10] HUTLEY, M.C., DALY, D., and STEVENS, R.F., The testing of microlens arrays, *IOP Short meeting series No. 30 Microlens Arrays*, Teddington UK, 1991, pp. 67-81
- [11] BÜTTNER, A., and ZEITNER, U.D., Calculation of the average lenslet shape and aberrations of microlens arrays from their far-field intensity distribution. *Applied Optics*, **41**(32), 2002, pp. 6841-6848
- [12] MALACARA, D., *Optical shop testing*, Wiley & sons, 1992
- [13] KOHLER, D.R., and GAMIZ, V.L., Interferogram reduction for radial-shear and local-reference holographic interferograms. *Applied Optics*, **25** (10), 1986, p. 1650
- [14] DALY, D., *Microlens Arrays*. Taylor and Francis, 2001
- [15] MIYASHITA, T., *et al.* Wavefront aberration measuring method for microlens using the Mach-Zehnder interferometer combining with an effective aperture (I), Institute of Physics, London, *Micro Optics and Lens Arrays*, Friday 14 September, 2001
- [16] MIYASHITA, T., *et al.* Wavefront aberration measurement technology for microlens using the Mach-Zehnder interferometer provided with a projected aperture. *Proc. SPIE*, **Vol. 5532**, 2004, pp. 117-127
- [17] KATO, M., *et al.* Equivalence between the software-determined and the hardware-determined effective numerical aperture in the interferometrical measuring of microlens. *Proc. SPIE*, **Vol. 5532**, 2004, pp. 136-146
- [18] SICKINGER, H., SCHWIDER, J., and MANZKE, B., Fiber based Mach-Zehnder interferometer for measuring wave aberrations of microlenses. *Optik*, **110**, 1999, pp. 239-243
- [19] SICKINGER, H., FALKENSTÖRFER, O., LINDLEIN, N., and SCHWIDER, J., Characterisation of microlenses using a phase-shifting shearing interferometer. *Opt. Eng.* **33**, 1994, pp. 2680-2686
- [20] SCHREIBER, H., and SCHWIDER, J., A lateral shearing interferometer based on two Ronchi-phase gratings in series. *Appl. Opt.*, **36**, 1997, pp. 5321-5324





## Bureau of Indian Standards

BIS is a statutory institution established under the *Bureau of Indian Standards Act, 2016* to promote harmonious development of the activities of standardization, marking and quality certification of goods and attending to connected matters in the country.

### Copyright

BIS has the copyright of all its publications. No part of these publications may be reproduced in any form without the prior permission in writing of BIS. This does not preclude the free use, in the course of implementing the standard, of necessary details, such as symbols and sizes, type or grade designations. Enquiries relating to copyright be addressed to the Head (Publication & Sales), BIS.

### Review of Indian Standards

Amendments are issued to standards as the need arises on the basis of comments. Standards are also reviewed periodically; a standard along with amendments is reaffirmed when such review indicates that no changes are needed; if the review indicates that changes are needed, it is taken up for revision. Users of Indian Standards should ascertain that they are in possession of the latest amendments or edition by referring to the website-[www.bis.gov.in](http://www.bis.gov.in) or [www.standardsbis.in](http://www.standardsbis.in).

This Indian Standard has been developed from Doc No.: PGD 39 (24219).

### Amendments Issued Since Publication

Amend No.	Date of Issue	Text Affected

## BUREAU OF INDIAN STANDARDS

### Headquarters:

Manak Bhavan, 9 Bahadur Shah Zafar Marg, New Delhi 110002

Telephones: 2323 0131, 2323 3375, 2323 9402

Website: [www.bis.gov.in](http://www.bis.gov.in)

### Regional Offices:

Central : 601/A, Konnectus Tower -1, 6<sup>th</sup> Floor,  
DMRC Building, Bhavbhuti Marg, New  
Delhi 110002

Telephones

{ 2323 7617

Eastern : 8<sup>th</sup> Floor, Plot No 7/7 & 7/8, CP Block, Sector V,  
Salt Lake, Kolkata, West Bengal 700091

{ 2367 0012  
2320 9474

Northern : Plot No. 4-A, Sector 27-B, Madhya Marg,  
Chandigarh 160019

{ 265 9930

Southern : C.I.T. Campus, IV Cross Road, Taramani, Chennai 600113

{ 2254 1442  
2254 1216

Western : 5<sup>th</sup> Floor/MTNL CETTM, Technology Street, Hiranandani Gardens, Powai  
Mumbai 400076

{ 25700030  
25702715

**Branches :** AHMEDABAD, BENGALURU, BHOPAL, BHUBANESHWAR, CHANDIGARH, CHENNAI, COIMBATORE, DEHRADUN, DELHI, FARIDABAD, GHAZIABAD, GUWAHATI, HARYANA (CHANDIGARH), HUBLI, HYDERABAD, JAIPUR, JAMMU, JAMSHEDPUR, KOCHI, KOLKATA, LUCKNOW, MADURAI, MUMBAI, NAGPUR, NOIDA, PARWANOO, PATNA, PUNE, RAIPUR, RAJKOT, SURAT, VIJAYAWADA.