प्रकाशिकी और फोटोनिक्स — प्रकाशीय तत्वों
और प्रणालियों के लिए आरेखण तैयार करना
भाग 8 गैर गोलाकार सतहें

Optics and Photonics — Preparation
of Drawings for Optical Elements
and Systems
Part 8 Aspheric Surfaces

ICS 01.100.20; 37.020

© BIS 2024
© ISO 2019



भारतीय मानक ब्यूरो
BUREAU OF INDIAN STANDARDS
मानक भवन, 9 बहादुर शाह ज़फर मार्ग, नई दिल्ली - 110002
MANAK BHAVAN, 9 BAHADUR SHAH ZAFAR MARG
NEW DELHI - 110002

www.bis.gov.in www.standardsbis.in

NATIONAL FOREWORD

This Indian Standard (Part 8) which is identical to ISO 10110-12 : 2019 'Optics and photonics — Preparation of drawings for optical elements and systems — Part 12: Aspheric surfaces' issued by the International Organization for Standardization (ISO) was adopted by the Bureau of Indian Standards on the recommendation of the Optics and Photonics Sectional Committee and after approval of the Production and General Engineering Division Council.

This standard specifies rules for presentation of aspheric surfaces and surfaces with low order symmetry such as cylinders and toroids.

IS 5920 (Part 1) supersedes the originally published Indian Standard IS 5920 : 1970 'Recommendation for the preparation of drawing for optical elements and system'.

This standard has been published in thirteen parts. The other parts in this series are:

Part 1	General
Part 2	Surface form tolerances
Part 3	Centering tolerances
Part 4	Surface imperfections
Part 5	Surface texture
Part 6	Surface treatment and coating
Part 7	Non-tolerance data
Part 9	Wave front deformation tolerance
Part 10	Diffraction surfaces
Part 11	Laser irradiation damage threshold
Part 12	Stress birefringence, bubbles and inclusions, homogeneity, and striae
Part 13	General description of surfaces and components

The text of ISO standard has been approved as suitable for publication as an Indian Standard without deviations. Certain conventions are, however, not identical to those used in Indian Standards. Attention is particularly drawn to the following:

- a) Wherever the words 'International Standard' appear referring to this standard, they should be read as 'Indian Standard'; and
- b) Comma (,) has been used as a decimal marker while in Indian Standards, the current-practice is to use a point (.) as the decimal marker.

In this adopted standard, references appear to certain International Standards for which Indian Standards also exist. The corresponding Indian Standards, which are to be substituted in their respective places, are listed below along with their degrees of equivalence for the editions indicated:

<i>International Standard</i>	<i>Corresponding Indian Standard</i>	<i>Degree of Equivalence</i>
ISO 1101 : 2017 Geometrical product specifications (GPS) — Geometrical tolerancing — Tolerances of form, orientation, location and run-out	IS 8000 (Part 1) : 2019/ISO 1101 : 2017 Geometrical product specifications (GPS) — Geometrical tolerancing: Part 1 Tolerances of form, orientation, location and run-out (<i>second revision</i>)	Identical

[*\(Continued on third cover\)*](#)

Contents

Page

1	Scope	1
2	Normative references	1
3	Terms and definitions	1
4	Mathematical description of aspheric surfaces	2
4.1	Coordinate system	2
4.2	Sign conventions	2
4.3	Surface descriptions	3
4.3.1	General	3
4.3.2	Surface description — Rotationally invariant ($h^2 = x^2 + y^2$)	3
4.3.3	Surface description — Rotationally variant	7
5	Indications in drawings	10
5.1	Indication of the theoretical surface	10
5.2	Indication of surface form tolerances	11
5.3	Indication of centring tolerances	11
5.4	Indication of surface imperfection and surface texture tolerances	11
6	Examples	11
6.1	Parts with rotationally invariant surfaces	11
6.2	Parts with rotationally variant surfaces	17
	Annex A (informative) Summary of aspheric surface types	19
	Annex B (informative) Description of orthonormal in slope aspheres	22
	Annex C (informative) Description of orthonormal in amplitude aspheres	24
	Bibliography	26

Indian Standard

OPTICS AND PHOTONICS — PREPARATION OF DRAWINGS
FOR OPTICAL ELEMENTS AND SYSTEMS
PART 8 ASPHERIC SURFACES

1 Scope

This document specifies rules for presentation of aspheric surfaces and surfaces with low order symmetry such as cylinders and toroids in the ISO 10110 series, which standardizes drawing indications for optical elements and systems. It also specifies sign conventions and coordinate systems.

This document does not apply to off-axis aspheric and discontinuous surfaces such as Fresnel surfaces or gratings.

NOTE For off-axis aspheric and non-symmetric surfaces, see ISO 10110-19.

This document does not specify the method by which conformity with the specifications is tested.

2 Normative references

The following documents are referred to in the text in such a way that some or all of their content constitutes requirements of this document. For dated references, only the edition cited applies. For undated references, the latest edition of the referenced document (including any amendments) applies.

ISO 1101:2017, *Geometrical product specifications (GPS) — Geometrical tolerancing — Tolerances of form, orientation, location and run-out*

ISO 10110-1, *Optics and photonics — Preparation of drawings for optical elements and systems — Part 1: General*

ISO 10110-5, *Optics and photonics — Preparation of drawings for optical elements and systems — Part 5: Surface form tolerances*

ISO 10110-6, *Optics and photonics — Preparation of drawings for optical elements and systems — Part 6: Centring tolerances*

ISO 10110-7, *Optics and photonics — Preparation of drawings for optical elements and systems — Part 7: Surface imperfections*

ISO 10110-8, *Optics and photonics — Preparation of drawings for optical elements and systems — Part 8: Surface texture*

3 Terms and definitions

No terms and definitions are listed in this document.

ISO and IEC maintain terminological databases for use in standardization at the following addresses:

- ISO Online browsing platform: available at <https://www.iso.org/obp>
- IEC Electropedia: available at <http://www.electropedia.org/>

4 Mathematical description of aspheric surfaces

4.1 Coordinate system

Aspheric surfaces are described in a right-handed, orthogonal coordinate system in which the Z axis is the optical axis.

Unless otherwise specified, the Z axis is in the plane of the drawing and runs from left to right; if only one cross section is drawn, the Y axis is in the plane of the drawing and is oriented upwards.

The origin of the coordinate system is at the vertex of the aspheric surface (see [Figure 1](#)).

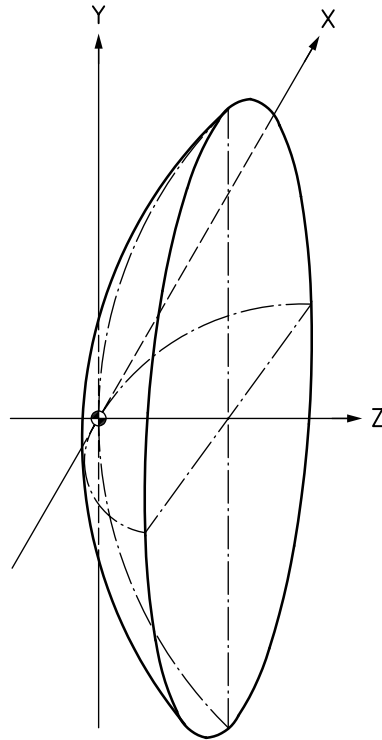

Figure 1 — Coordinate system

4.2 Sign conventions

As shown later in this document, the various types of aspheric surfaces are given by mathematical formulae. In the drawings the chosen formula and the corresponding constants and coefficients are specified. To achieve unambiguous indications of the surfaces, sign conventions for the constants and coefficients shall be introduced.

The sign of the radius of curvature is positive if the centre of curvature is to the right of the vertex, and negative if the centre of curvature is to the left of the vertex.

The sagitta of a point of the aspheric surface is positive if this point is to the right of the vertex (XY plane) and negative if it is to the left of the vertex (XY plane).

NOTE 1 In this case, “left” and “right” presume Z is increasing from left to right. When the Z axis is reversed as a result of a reflection (a 180-degree rotation about the Y axis), the sign convention for radius and sagitta is also reversed. This is discussed further in [4.3](#).

NOTE 2 This is the default sign convention, assuming no coordinate system according to ISO 10110-1:2019, 5.3 has been defined for the surface of interest. See ISO 10110-1 for more information about defining local coordinate systems.

4.3 Surface descriptions

4.3.1 General

The phrase “aspheric surfaces” is commonly used in optics to describe rotationally invariant surfaces such as are described below in [4.3.2](#). Surface descriptions for surfaces which are not rotationally invariant such as cylindrical surfaces are described in [4.3.3](#). More complex optical surfaces can be described using the methods given in ISO 10110-19.

4.3.2 Surface description — Rotationally invariant ($h^2 = x^2 + y^2$)

4.3.2.1 Aspheric surface described by a conic section and a power series

The aspheric surface description consists of a conic part and a power series where the axis of rotation is the Z axis.

$$z(h) = \frac{h^2}{R \left[1 + \sqrt{1 - (1 + \kappa) \left(\frac{h}{R} \right)^2} \right]} + \sum_{i=2}^n A_{2i} h^{2i} \quad (1)$$

where

- z is the sagitta;
- h is surface height perpendicular to Z-axis ($h \geq 0$);
- R is the radius of curvature of the base sphere;
- κ is the conic constant;
- A_i is the aspheric coefficient.

Where the basic conic formula behaves as follow:

- $\kappa > 0$ oblate ellipse;
- $\kappa = 0$ circle;
- $-1 < \kappa < 0$ prolate ellipse;
- $\kappa = -1$ parabola;
- $\kappa < -1$ hyperbola.

NOTE 1 The formula of second order can also be used without the power series.

NOTE 2 In three dimensions, the conic formula shapes are called ellipsoid, sphere, paraboloid, and hyperboloid.

For an example drawing, see [Figure 4](#).

An extended version with the complete power series of this description is described in [Formula \(2\)](#).

$$z(h) = \frac{h^2}{R \left[1 + \sqrt{1 - (1 + \kappa) \left(\frac{h}{R} \right)^2} \right]} + \sum_{i=1}^n A_i h^i \quad (2)$$

In a special version this formula describes an axicon:

$$z(h) = A_1 h \quad (3)$$

Care should be taken that the signs of the power series named formulae $z(h)$ are in accordance with the conventions defined in [4.1](#) and [4.2](#).

In the case where the direction of the Z axis is reversed, but the lens stays unchanged, the signs of the radius of curvature and of the aspheric coefficients shall be changed. The signs of the conic constants remain unchanged.

4.3.2.2 Aspheric surface described by a conic section and orthogonal polynomials

4.3.2.2.1 Orthonormal in slope aspheres with spherical base

A surface of higher order can also be generated by combining a spherical surface with a polynomial of the following kind, which has orthonormal derivatives.

$$z(h) = \frac{h^2}{R \left[1 + \sqrt{1 - \left(\frac{h}{R} \right)^2} \right]} + \frac{w^2 [1 - w^2]}{\sqrt{1 - \left(\frac{h}{R} \right)^2}} \sum_{m=0}^n B_m Q_m^{\text{bfs}}(w^2) \quad (4)$$

where

R is the radius of curvature of the base sphere;

h is the surface height;

h_0 marks the upper limit of h ; and

w (normalized surface height) is defined as $w = \frac{h}{h_0}$;

B_m is the coefficient; and

Q_m^{bfs} is the polynomial term.

The description z is valid for $0 \leq h \leq h_0$ only. The formula for the polynomial terms is

$$Q_{m+1}^{\text{bfs}}(w^2) = [P_{m+1}(w^2) - g_m Q_m^{\text{bfs}}(w^2) - k_{m-1} Q_{m-1}^{\text{bfs}}(w^2)] / l_{m+1} \quad (5)$$

starting with

$$Q_0^{\text{bfs}}(w^2) = 1 \quad (6)$$

$$Q_1^{\text{bfs}}(w^2) = \frac{1}{\sqrt{19}} (13 - 16w^2) \quad (7)$$

$$Q_2^{\text{bfs}}(w^2) = \sqrt{\frac{2}{95}} [29 - 4w^2(25 - 19w^2)] \quad (8)$$

$$P_{m+1}(w^2) = (2 - 4w^2)P_m(w^2) - P_{m-1}(w^2) \quad (9)$$

starting with

$$P_0(w^2) = 2 \quad (10)$$

$$P_1(w^2) = 6 - 8w^2 \quad (11)$$

These auxiliary polynomials have to be solved in the order given here and are valid for $m \geq 2$.

$$k_{m-2} = -m(m-1)/2l_{m-2} \quad (12)$$

$$g_{m-1} = -(1 + g_{m-2}k_{m-2})/l_{m-1} \quad (13)$$

$$l_m = [m(m+1) + 3 - g_{m-1}^2 - k_{m-2}^2]^{1/2} \quad (14)$$

starting with

$$g_0 = -\frac{1}{2} \quad (15)$$

$$l_0 = 2 \quad (16)$$

$$l_1 = \frac{1}{2}\sqrt{19} \quad (17)$$

NOTE 1 $Q_2^{\text{bfs}}(w^2)$ is given above to be used as a check of the recursion algorithm provided in [Formulae \(5\)](#) through [\(17\)](#). See also [Annex B](#).

NOTE 2 “bfs” is an abbreviation for “best fit sphere”, which matches the sag of the aspherical surface at the vertex and h_0 .

For an example drawing, see [Figure 5](#).

4.3.2.2.2 Orthonormal in slope aspheres with conic base

It is also possible to generate a surface by combining a conical surface with a polynomial of the same kind as in [Formula \(4\)](#). This kind is also an orthonormal set of polynomials.

$$z(h) = \frac{h^2}{R \left[1 + \sqrt{1 - (1 + \kappa) \left(\frac{h}{R} \right)^2} \right]} + \frac{w^2 [1 - w^2]}{\sqrt{1 - \left(\frac{h}{R} \right)^2}} \sum_{m=0}^n B_m Q_m^{\text{bfs}}(w^2) \quad (18)$$

where

- R is the radius of curvature of the base sphere;
- h is the surface height;
- h_0 marks the upper limit of h ;
- w (normalized surface height) is defined as $w = \frac{h}{h_0}$;
- κ is the conic constant;
- B_m are the coefficients; and
- Q_m^{bfs} are the polynomial terms.

4.3.2.2.3 Orthonormal in amplitude aspheres

A surface of higher order can also be generated by combining a conical surface with a polynomial of the following kind, which has orthonormal amplitudes.

$$z(h) = \frac{h^2}{R \left[1 + \sqrt{1 - (1 + \kappa) \left(\frac{h}{R} \right)^2} \right]} + w^4 \sum_{m=0}^n C_m Q_m^{\text{con}}(w^2) \quad (19)$$

where

- R is the radius of curvature of the base sphere;
- h is the surface height;
- h_0 marks the upper limit of h ; and
- w (normalized surface height) is defined as $w = \frac{h}{h_0}$;
- κ is the conic constant;
- C_m are the coefficients; and
- Q_m^{con} are the polynomial terms.

The formula for the polynomial terms is

$$Q_m^{\text{con}}(w^2) = T_m(2w^2 - 1) \quad (20)$$

starting with

$$Q_0^{\text{con}}(w^2) = 1 \quad (21)$$

$$Q_1^{\text{con}}(w^2) = -(5 - 6w^2) \quad (22)$$

$$Q_2^{\text{con}}(w^2) = 15 - 14w^2(3 - 2w^2) \quad (23)$$

$$T_m(w^2) = \left[(b(m) + c(m)w^2)T_{m-1}(w^2) - d(m)T_{m-2}(w^2) \right] / a(m) \quad (24)$$

starting with

$$T_0(w^2) = 1 \quad (25)$$

$$T_1(w^2) = 3w^2 - 2 \quad (26)$$

These auxiliary polynomials have to be solved in the order given here and are valid for $m \geq 2$.

$$a(m) = 2m(m+4)(2m+2) \quad (27)$$

$$b(m) = -32m - 48 \quad (28)$$

$$c(m) = (2m+2)(2m+3)(2m+4) \quad (29)$$

$$d(m) = 2(m-1)(m+3)(2m+4) \quad (30)$$

NOTE 1 $Q_0^{\text{con}}(w^2)$, $Q_1^{\text{con}}(w^2)$ and $Q_2^{\text{con}}(w^2)$ are given above to be used as a check of the recursion algorithm provided in [Formulae \(20\)](#) through [\(30\)](#). See also [Annex C](#).

NOTE 2 The polynomial form given here is identical to Zernike radial polynomial expansion $R_{2n}^q(w^2)$ of order $q = 4$ correlated to ISO/TR 14999-2 as $w^4 Q_m^{\text{con}}(w^2) = R_{2n}^4(w^2)$ with $n = m + 2$, and $m = 0, 1, 2, 3, 4, 5, 6 \dots$

NOTE 3 Instead of using the recursion algorithm above, for lower orders of m ($m \leq 8$), the polynomials can easily be computed using the formula $Q_m^{\text{con}}(w^2) = \sum_{s=0}^m (-1)^s \frac{(2m+4-s)!}{s!(m+4-s)!(m-s)!} w^{2(m-s)}$.

For an example drawing, see [Figure 6](#).

4.3.3 Surface description — Rotationally variant

4.3.3.1 Centred quadrics

In the coordinate system given in [4.1](#), the formulae of the surfaces of second order which fall within the scope of this document are derived from the canonical forms

$$\frac{x^2}{a^2} + \frac{y^2}{b^2} + \frac{z^2}{c^2} = 1 \quad \text{for centered quadrics} \quad (31)$$

where

a, b are real or imaginary constants;

c is a real constant.

$$\frac{x^2}{a^2} + \frac{y^2}{b^2} + 2z = 0 \quad \text{for parabolic surfaces} \quad (32)$$

where a, b are real or imaginary constants, and can be written as

$$z = f(x, y) = \frac{\frac{x^2}{R_X} + \frac{y^2}{R_Y}}{1 + \sqrt{1 - (1 + \kappa_X) \left(\frac{x}{R_X}\right)^2 - (1 + \kappa_Y) \left(\frac{y}{R_Y}\right)^2}} \quad (33)$$

where

R_X is the radius of curvature in the XZ plane;

R_Y is the radius of curvature in the YZ plane;

κ_X, κ_Y are conic constants.

Using curvatures $C_X = 1/R_X$ and $C_Y = 1/R_Y$ instead of radii yields

$$z = f(x, y) = \frac{x^2 C_X + y^2 C_Y}{1 + \sqrt{1 - (1 + \kappa_X) (x C_X)^2 - (1 + \kappa_Y) (y C_Y)^2}} \quad (34)$$

If the surface according to [Formula \(33\)](#) or [\(34\)](#) is intersected with the XZ plane ($y = 0$) or the YZ plane ($x = 0$), then, depending on the value of κ_Y (or κ_X), intersection lines of the following types are produced:

$\kappa > 0$ oblate ellipse;

$\kappa = 0$ circle;

$-1 < \kappa < 0$ prolate ellipse;

$\kappa = -1$ parabola;

$\kappa < -1$ hyperbola.

4.3.3.2 Cylinders

[Formulae \(35\)](#) and [\(36\)](#) describe a cylinder (due to κ_U not necessarily of circular cross section). For $u = x$, the cylinder vertex line is parallel to the Y axis which is perpendicular to the XZ plane. For $u = y$ the cylinder vertex line is parallel to the X axis which is perpendicular to the YZ plane.

Using radii:

For $R_X = \infty$ or $R_Y = \infty$ [Formula \(33\)](#) gives

$$z = f(u) = \frac{u^2}{R_U \left[1 + \sqrt{1 - (1 + \kappa_U) \left(\frac{u}{R_U}\right)^2} \right]} \quad (35)$$

Using curvatures:

For $C_X = 0$ or $C_Y = 0$ [Formula \(34\)](#) gives

$$z = f(u) = \frac{u^2 C_U}{1 + \sqrt{1 - (1 + \kappa_U) u^2 C_U^2}} \quad (36)$$

4.3.3.3 Polynomials

The formula for polynomial surfaces is

$$z = f(x, y) = A_2 x^2 + B_2 y^2 + A_4 x^4 + B_4 y^4 + A_6 x^6 + B_6 y^6 + \dots + C_3 |x|^3 + \dots + D_3 |y|^3 + \dots \quad (37)$$

Alternatively, this formula can be shown as a summation

$$z = f(x, y) = \sum_{i=2}^n (A_i |x|^i + B_i |y|^i) \quad (38)$$

4.3.3.4 Toric surfaces

A toric surface is generated by the rotation of a defining curve, contained in a plane, about an axis which lies in the same plane.

The formula of a toric surface having its defining curve, $z = g(x)$, in the XZ plane and its axis of rotation parallel to the X axis is

$$z = f(x, y) = R_Y \mp \sqrt{[R_Y - g(x)]^2 - y^2} \quad (39)$$

where R_Y is the z-coordinate at which the axis of rotation intersects the Z axis.

For the purpose of this document, $g(x)$ is derived from [Formula \(33\)](#) by setting $y = 0$.

$$g(x) = \frac{x^2}{R_X \left[1 + \sqrt{1 - (1 + \kappa_X) \left(\frac{x}{R_X} \right)^2} \right]} \quad (40)$$

The formula of a toric surface having its defining curve in the YZ plane and its axis of rotation parallel to the Y axis may be obtained from [Formulae \(39\)](#) and [\(40\)](#) by interchanging x with y , R_X with R_Y and κ_X with κ_Y .

The following special case of [Formulae \(39\)](#) and [\(40\)](#) should be mentioned:

If $\kappa_X = 0$

$$g(x) = R_X \left[1 - \sqrt{1 - \left(\frac{x}{R_X} \right)^2} \right] \quad (41)$$

and

$$f(x, y) = R_Y \mp \sqrt{\left[R_Y - R_X + R_X \sqrt{1 - \left(\frac{x}{R_X} \right)^2} \right]^2 - y^2} \quad (42)$$

[Formula \(42\)](#) describes a torus whose defining curve is a circle with radius R_X .

4.3.3.5 Conical surfaces

The canonical form

$$\frac{x^2}{a^2} + \frac{y^2}{b^2} + \frac{z^2}{c^2} = 0 \quad (43)$$

where

a, b are imaginary constants;

c is a real constant;

leads to Formula (44)

$$z = f(x, y) = c \sqrt{\frac{x^2}{a^2} + \frac{y^2}{b^2}} \quad (44)$$

where a, b, c are real constants.

This formula describes a cone with its tip at the origin, with elliptical cross section (if $a \neq b$) or with circular cross section (if $a = b$).

4.3.3.6 Combinations of surface types

If necessary, surface types can be modified by the addition of another function $f_1(x, y)$. The complete formula of the surface is then

$$z = f(x, y) + f_1(x, y) \quad (45)$$

where

$f(x, y)$ where represents the basic form according to [Formulae \(33\)](#) and [\(34\)](#) or one of their derivatives and

$f_1(x, y)$ represents polynomial surface functions like [Formula \(37\)](#).

For cylindrical surfaces, the defining curve $f(u)$ can be modified by addition of a power series $f_1(u)$ (see [Annex A](#).) For toric surfaces, the defining curve $g(x)$ can be modified by addition of a power series $g_1(x)$ (see [Annex A](#).)

Care should be taken that the signs of the coefficients [[Formula \(45\)](#)] in $f(x, y)$ and $f_1(x, y)$ [or for toric surfaces the signs of the coefficients $g(x, y)$ and $g_1(x, y)$] are in accordance with the conventions defined in [4.1](#) and [4.2](#). In the case where the direction of the Z axis shall be reversed, the signs of the radii and curvatures and of the coefficients for [Formula \(37\)](#) or [\(38\)](#) shall be changed. The signs of the conic constants remain unchanged.

5 Indications in drawings

5.1 Indication of the theoretical surface

The formula describing the aspheric surface shall be given.

The radius of curvature is indicated with a sign, in accordance with [4.2](#).

The surface type shall be given as described in ISO 10110-1.

A sagitta table having sufficient numerical accuracy shall be included on the drawing (see [Figures 2 and 3](#)).

5.2 Indication of surface form tolerances

Surface form tolerances shall be indicated in one of the following ways:

- a) in accordance with ISO 1101; or
- b) in accordance with ISO 10110-5;

NOTE The specification in version ISO 10110-12:2007 has been adapted and moved to ISO 10110-5.

5.3 Indication of centring tolerances

Centring tolerances shall be indicated in accordance with either ISO 1101 or ISO 10110-6.

5.4 Indication of surface imperfection and surface texture tolerances

Tolerances for surface imperfections shall be indicated according to ISO 10110-7. Specifications of mid-spatial frequency ripple and surface texture shall be indicated according to ISO 10110-8.

6 Examples

6.1 Parts with rotationally invariant surfaces

In [Figure 2](#), an aspheric lens is shown, where the datum axis is established by centre of curvature of spherical surface A and the outer cylinder axis B determined at the circular target line, which is located at the intersection of the spherical surface with the outer cylinder in accordance with ISO 10110-6.

The form tolerance of the aspheric surface is given in tabular form. Δz is the maximum permissible deviation, in millimetres, in the Z direction for the given h coordinate. In addition, a slope deviation ΔS tolerance is indicated.

The centring tolerance is indicated in accordance with ISO 1101 as the maximum permissible axial run-out, and, alternatively, in accordance with ISO 10110-6 as the maximum permissible tilt angle (marked with index a).

Dimensions in millimetres

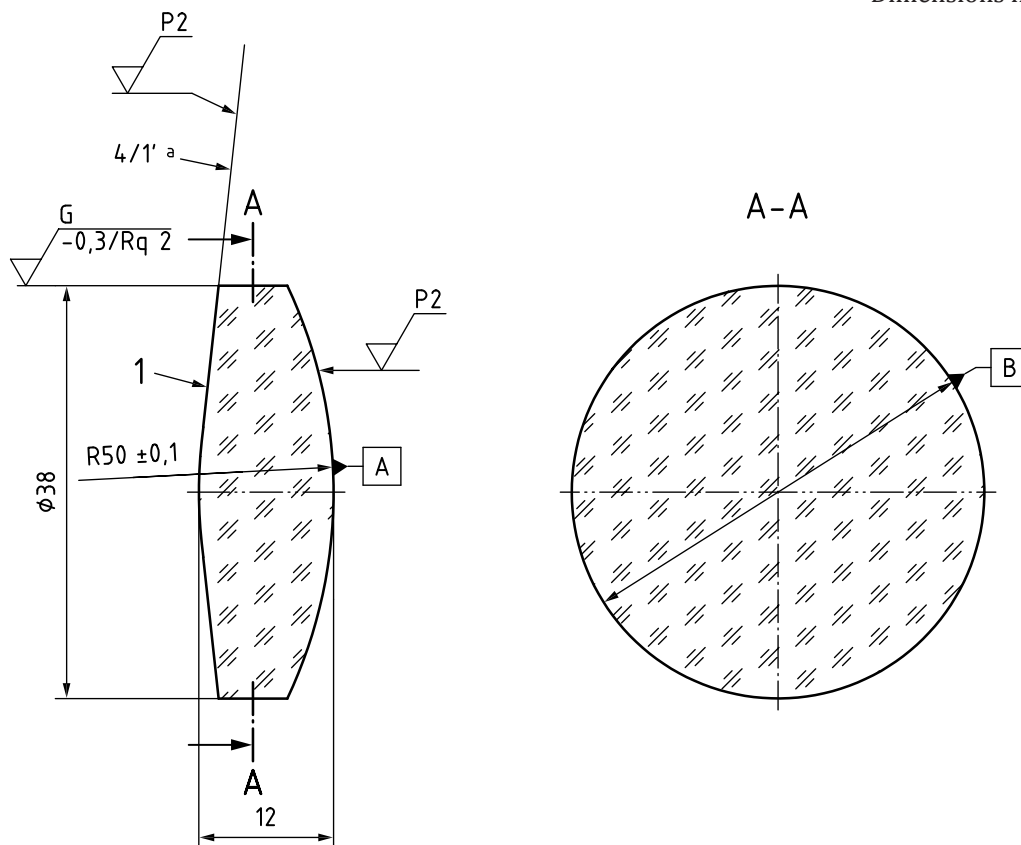

Key

1 asphere

$$z = \frac{h^2}{R \left(1 + \sqrt{1 - (1 + \kappa) h^2 / R^2} \right)} + \sum_{i=2}^5 (A_{2i} h^{2i})$$

^a Alternative indication of centring tolerance.

<i>h</i>	<i>Z</i>	Δz	ΔS
0,0	0,000	0,000	0,3'
5,0	0,219352	0,002	0,5'
10,0	0,825330	0,004	0,5'
15,0	1,600528	0,006	0,8'
19,0	1,938077	0,008	
			(1/0,1)

<i>R</i>	=	56,031
κ	=	-3
<i>A</i> ₄	=	-0,43264 E-05
<i>A</i> ₆	=	-0,97614 E-08
<i>A</i> ₈	=	-0,10852 E-11
<i>A</i> ₁₀	=	-0,12284 E-13

Figure 2 — Lens with a rotationally invariant aspheric surface

In [Figure 3](#) the drawing of an aspherical lens with the same geometrical shape as the lens in [Figure 2](#) but turned over (so that the asphere is the right surface) is shown. Note that the signs of the radius, *R* and of the coefficients *A_i* have changed. As a result the sagittas, *z*, have also changed sign.

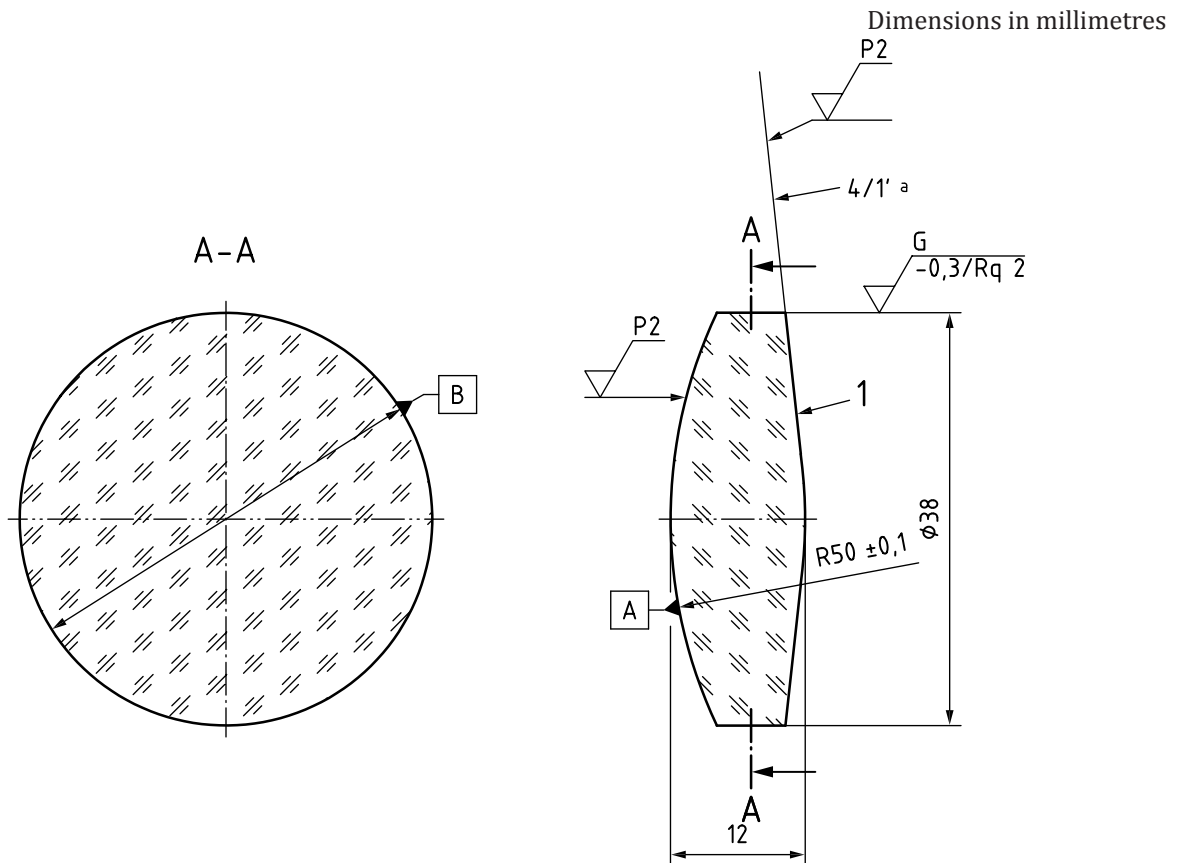

Key

1 asphere

$$z = \frac{h^2}{R \left(1 + \sqrt{1 - (1 + \kappa) h^2 / R^2} \right)} + \sum_{i=2}^5 (A_{2i} h^{2i})$$

^a Alternative indication of centring tolerance.

<i>h</i>	<i>Z</i>	Δz	ΔS
0,0	0,000	0,000	0,3'
5,0	-0,219352	0,002	0,5'
10,0	-0,825330	0,004	0,5'
15,0	-1,600528	0,006	0,8'
19,0	-1,938077	0,008	
			(1/0,1)

$$R = -56,031$$

$$\kappa = -3$$

$$A_4 = 0,43264 \text{ E-}05$$

$$A_6 = 0,97614 \text{ E-}08$$

$$A_8 = 0,10852 \text{ E-}11$$

$$A_{10} = 0,12284 \text{ E-}13$$

Figure 3 — Lens with a reversed rotationally invariant aspheric surface

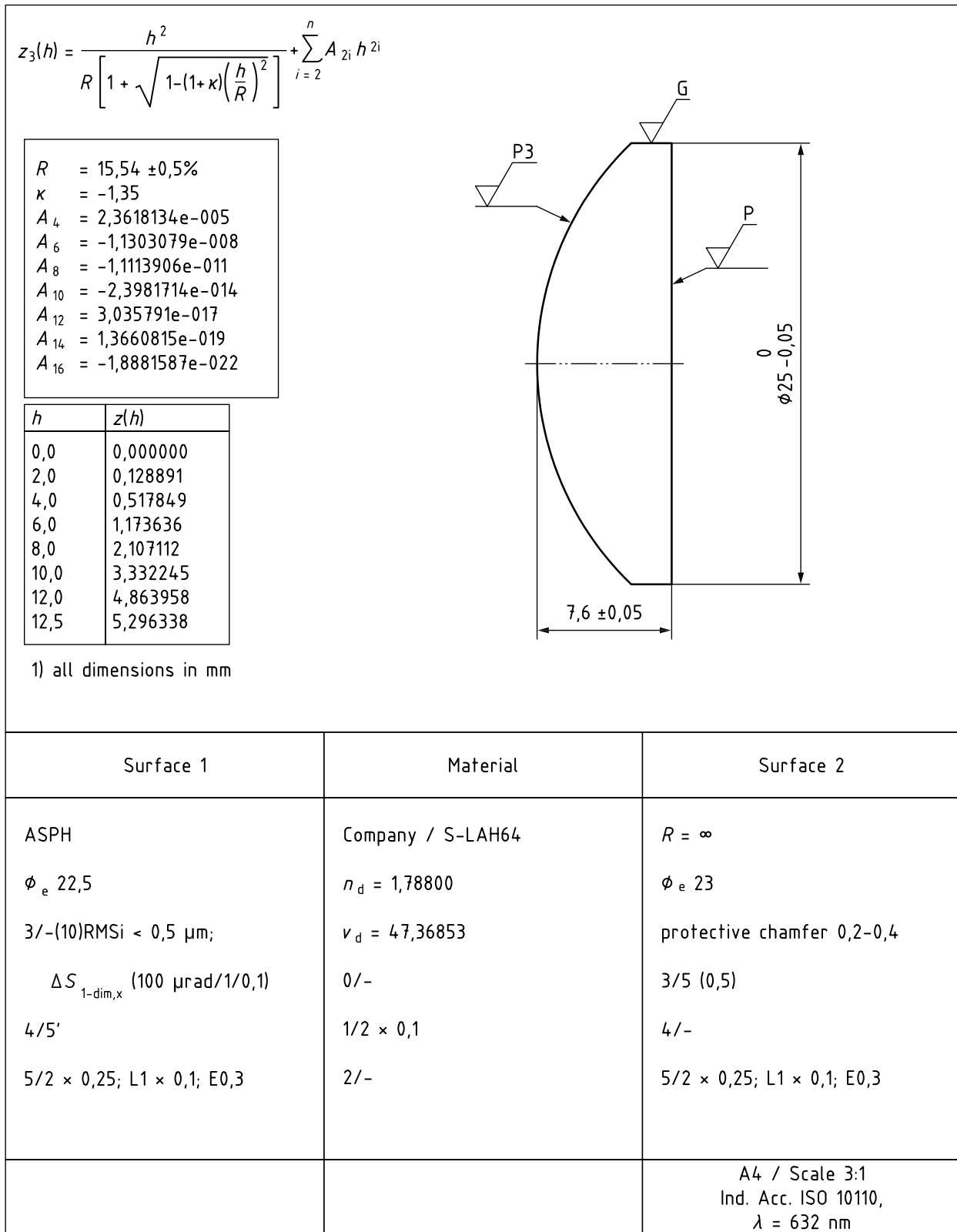

Figure 4 — Description of an aspherical surface with conic and power series

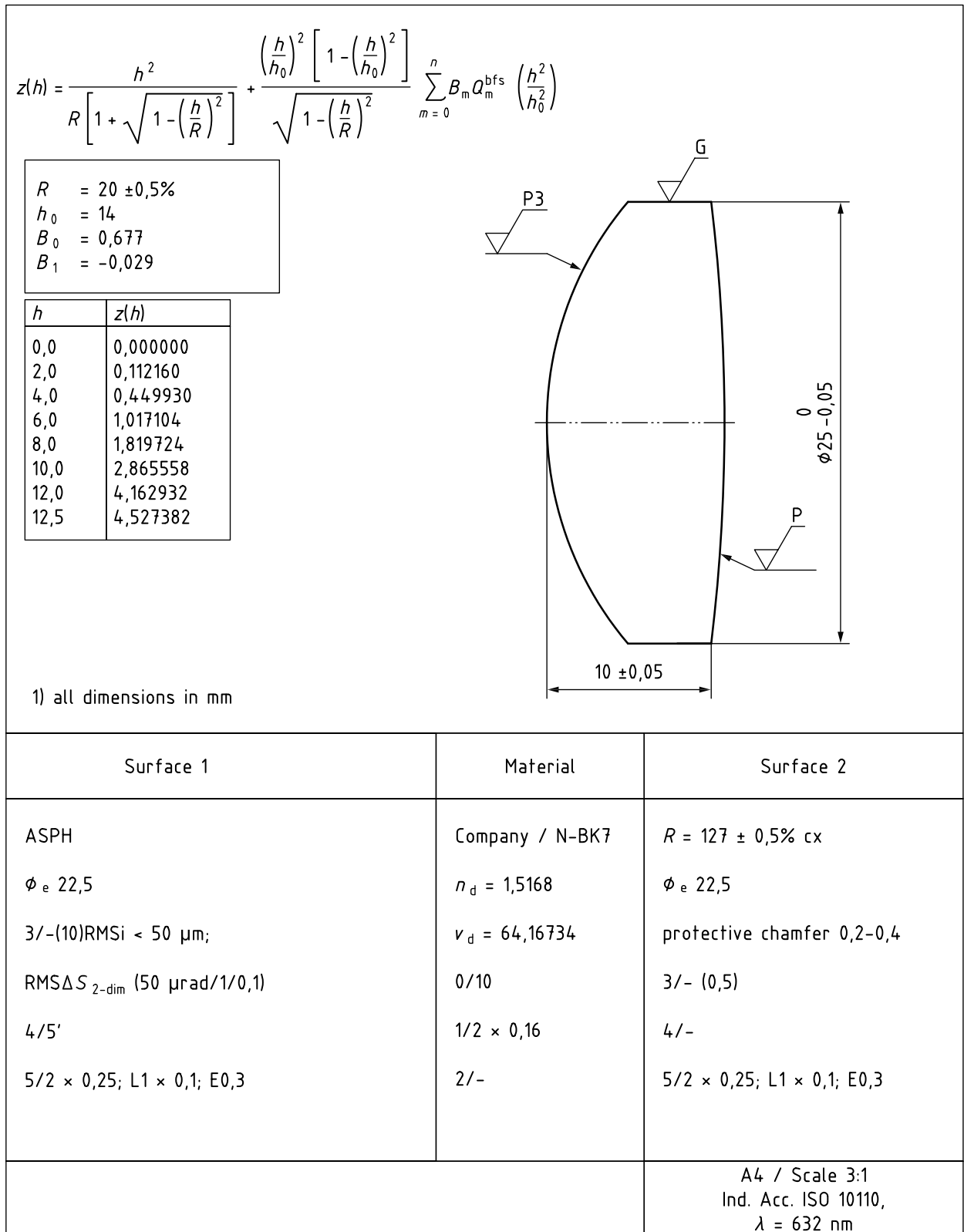

Figure 5 — Description of an aspherical surface using an orthonormal in slope asphere description

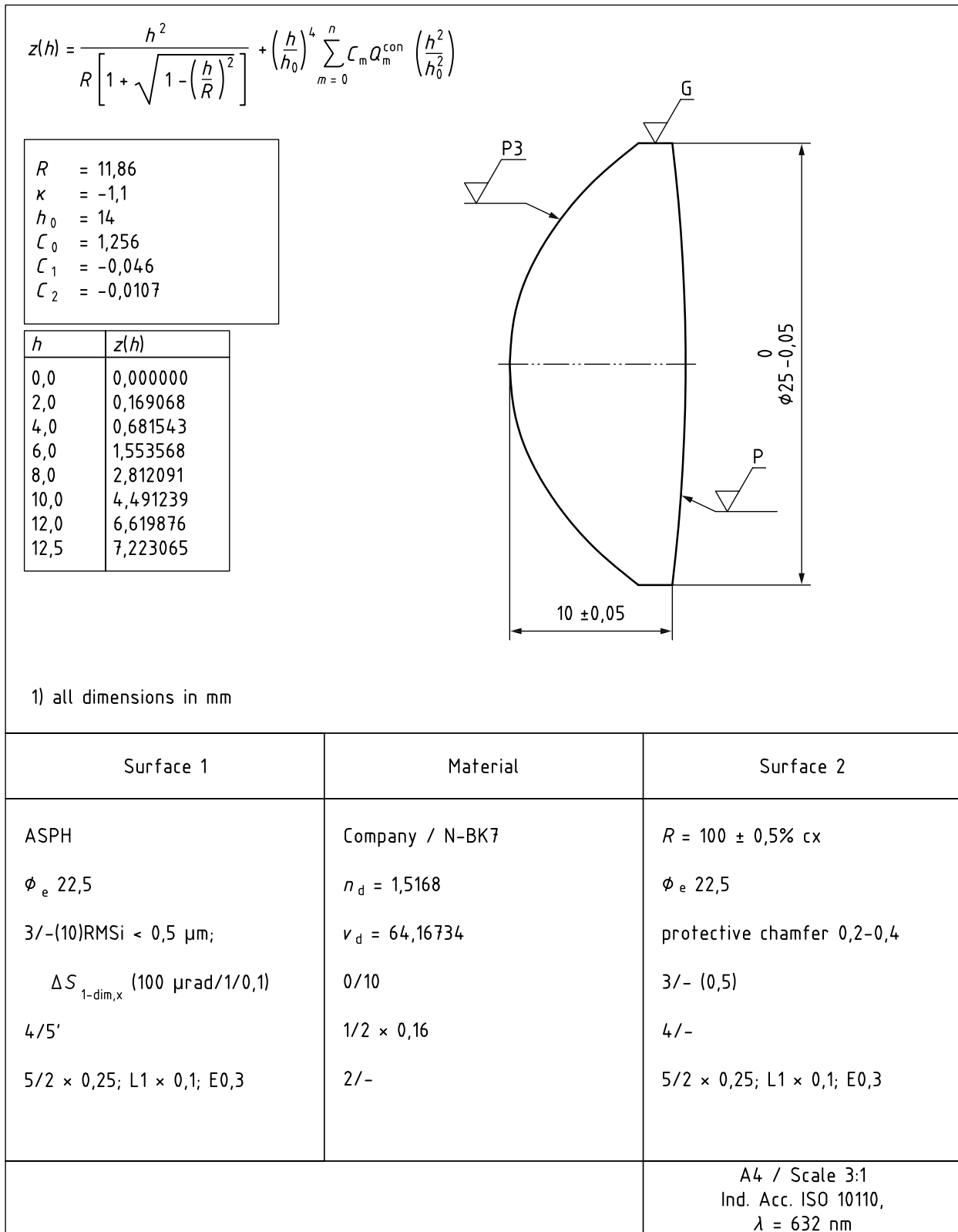

Figure 6 — Description of an aspherical surface using an orthonormal in amplitude asphere description

6.2 Parts with rotationally variant surfaces

[Figure 7](#) shows a planocylinder lens with rectangular cross section. The datum axis is given by the intersection of surfaces A and B.

The axis of the cylindrical surface shall be within a cylinder of diameter 0,05 mm.

The form error tolerance is specified in accordance with ISO 1101:2017, 17.5 and additionally by different slope deviation tolerances in the two sections.

Dimensions in millimetres

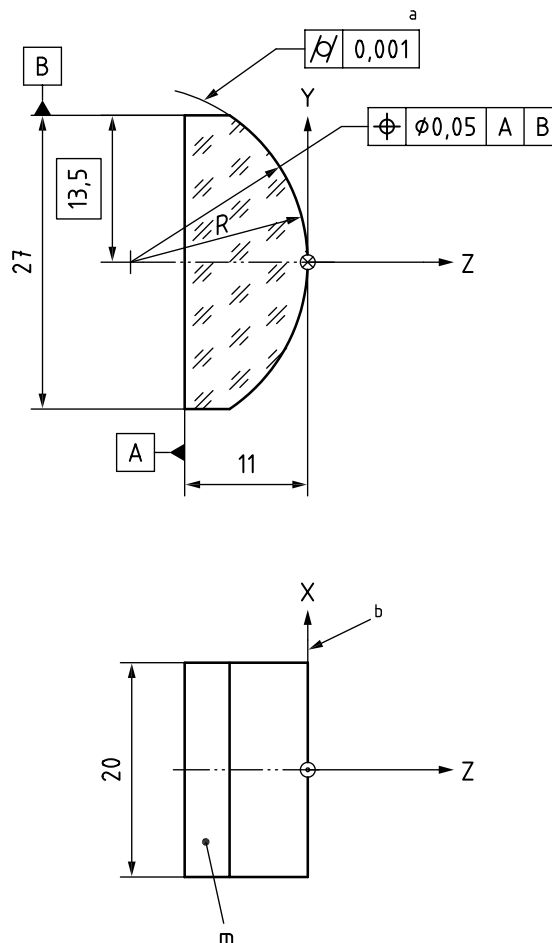

Key

- m mark for identification
- $R = -17,2 \pm 0,2$
- a $3/\Delta S_{1\text{-dim},Y}(0,5'/2/0,2)$
- b $3/\Delta S_{1\text{-dim},X}(1,0'/2/0,2)$

Figure 7 — Planocylinder lens

[Figure 8](#) shows a planotoric lens with circular cross section.

The datum axis is given by the edge cylinder B and the plano surface A.

The surface formula shown in the drawing indicates that defining arc and rotation axis of the surface lie in the XZ plane.

Different tolerances for the surface tilt angles are given in the two cross sections. Also, the (local) slope angle tolerances are different in the two cross sections.

Dimensions in millimetres

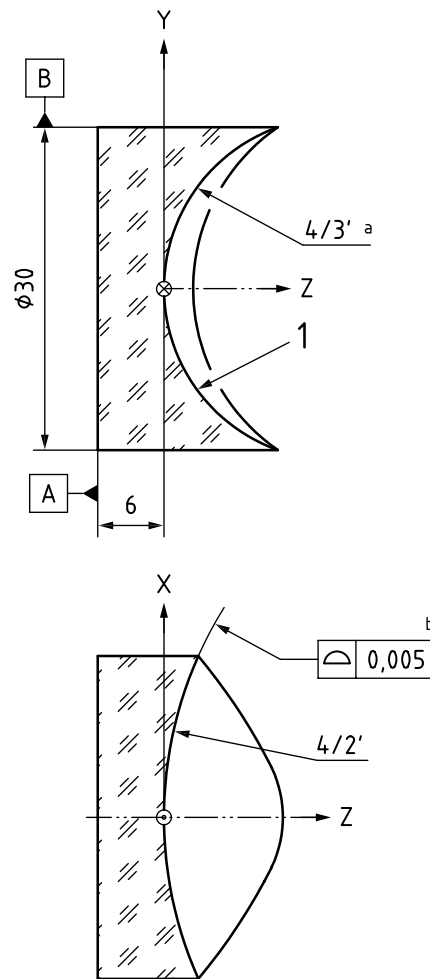

Key

1 TORIC

$$z = R_Y - \sqrt{\left[R_Y - R_X + \sqrt{R_X^2 - x^2} \right]^2 - y^2}$$

$$R_Y = 16 \pm 0,1$$

$$R_X = 40 \pm 0,2$$

$$a \quad 3/\Delta S_{1\text{-dim},Y} (0,5'/3/0,2)$$

$$b \quad 3/\Delta S_{1\text{-dim},X} (0,8'/3/0,2)$$

Figure 8 — Planotoric lens

Annex A (informative)

Summary of aspheric surface types

See [Table A.1](#).

Table A.1

Class	Basic surface type	Basic surface function	Additional power series term/polynomial
Rotationally invariant surface about Z axis	Sphere Ellipsoid Hyperboloid Paraboloid	$\frac{h^2}{R \left[1 + \sqrt{1 - (1 + \kappa) \left(\frac{h}{R} \right)^2} \right]}$	$\sum_{i=1}^n A_i h^i$ where $h = \sqrt{x^2 + y^2}$
	Plane	0	
Orthogonal in slope asphere Rotationally invariant surface about Z axis	Conoid (a = b)	$\frac{c}{a} h$	$\frac{w^2 (1 - w^2)}{\sqrt{1 - \left(\frac{h}{R} \right)^2}} \sum_{i=0}^n B_i Q_i^{\text{bfs}}(w^2)$ where $w = \frac{h}{h_0}, h = \sqrt{x^2 + y^2}$ Definition of $Q_i^{\text{bfs}}(w^2)$ in 4.3.2.2.1
	Sphere Ellipsoid Hyperboloid Paraboloid	$\frac{h^2}{R \left[1 + \sqrt{1 - (1 + \kappa) \left(\frac{h}{R} \right)^2} \right]}$	
Orthogonal in amplitude asphere Rotationally invariant surface about Z axis	Sphere Ellipsoid Hyperboloid Paraboloid	$\frac{h^2}{R \left[1 + \sqrt{1 - (1 + \kappa) \left(\frac{h}{R} \right)^2} \right]}$	$w^4 \sum_{i=0}^n C_i Q_i^{\text{con}}(w^2)$ where $w = \frac{h}{h_0}, h = \sqrt{x^2 + y^2}$ Definition of $Q_i^{\text{con}}(w^2)$ in 4.3.2.2.3

Table A.1 (continued)

Class	Basic surface type	Basic surface function	Additional power series term/polynomial
	Toroid	$R_Y \mp \sqrt{(R_Y - g(x))^2 - y^2}$ with $g(x) = \frac{x^2}{R_X \left[1 + \sqrt{1 - (1 + \kappa_X) \left(\frac{x}{R_X} \right)^2} \right]}$	$g_1(x) = \sum_{i=2}^n A_i x ^i$
Rotationally variant surface	Conoid	$\frac{\frac{x^2}{R_X} + \frac{y^2}{R_Y}}{1 + \sqrt{1 - (1 + \kappa_X) \left(\frac{x}{R_X} \right)^2 - (1 + \kappa_Y) \left(\frac{y}{R_Y} \right)^2}}$ or $c \sqrt{\frac{x^2}{a^2} + \frac{y^2}{b^2}}$	$\sum_{i=2}^n (A_i x ^i + B_i y ^i)$
Translationally invariant surface about X or Y axis	Cylinder	$\frac{u^2}{R_U \left[1 + \sqrt{1 - (1 + \kappa_U) \left(\frac{u}{R_U} \right)^2} \right]}$ where $u = x$ or y , $U = X$ or Y	$\sum_{i=2}^n A_i u ^i$ where $u = x$ or y

Annex B (informative)

Description of orthonormal in slope aspheres

The following formula describe the generation of the Q^{bfs} for [4.3.2.2.1](#) and [4.3.2.2.2](#):

$$Q_{m+1}^{\text{bfs}}(w^2) = [P_{m+1}(w^2) - g_m Q_m^{\text{bfs}}(w^2) - k_{m-1} Q_{m-1}^{\text{bfs}}(w^2)] / l_{m+1} \quad (\text{B.1})$$

$$P_{m+1}(w^2) = (2 - 4w^2)P_m(w^2) - P_{m-1}(w^2) \quad (\text{B.2})$$

starting with

$$P_0(w^2) = 2$$

$$P_1(w^2) = 6 - 8w^2.$$

The following auxiliary polynomials [\(B.3\)](#), [\(B.4\)](#) and [\(B.5\)](#) have to be solved in the order given here and are valid for $m \geq 2$.

$$k_{m-2} = -m(m-1) / 2l_{m-2} \quad (\text{B.3})$$

$$g_{m-1} = -(1 + g_{m-2}k_{m-2}) / l_{m-1} \quad (\text{B.4})$$

$$l_m = [m(m+1) + 3 - g_{m-1}^2 - k_{m-2}^2]^{1/2} \quad (\text{B.5})$$

starting with

$$g_0 = -\frac{1}{2} \quad (\text{B.6})$$

$$l_0 = 2 \quad (\text{B.7})$$

$$l_1 = \frac{1}{2}\sqrt{19} \quad (\text{B.8})$$

Based on the recursion the first six Q s are the following:

$$Q_0^{\text{bfs}}(w^2) = 1$$

$$Q_1^{\text{bfs}}(w^2) = \frac{1}{\sqrt{19}}(13 - 16w^2)$$

$$Q_2^{\text{bfs}}(w^2) = \sqrt{\frac{2}{95}} [29 - 4w^2(25 - 19w^2)]$$

$$Q_3^{\text{bfs}}(w^2) = \sqrt{\frac{2}{2545}} \{ 207 - 4w^2 [315 - w^2 (577 - 320w^2)] \}$$

$$Q_4^{\text{bfs}}(w^2) = \frac{1}{3\sqrt{131831}} (7737 - 16w^2 \{ 4653 - 2w^2 [7381 - 8w^2 (1168 - 509w^2)] \})$$

$$Q_5^{\text{bfs}}(w^2) = \frac{1}{3\sqrt{6632213}} [66657 - 32w^2 (28338 - w^2 \{ 135325 - 8w^2 [35884 - w^2 (34661 - 12432w^2)] \})]$$

Annex C (informative)

Description of orthonormal in amplitude aspheres

The following formulae describe the generation of the Q^{con} for [4.3.2.2.3](#):

$$Q_m^{\text{con}}(w^2) = T_m(2w^2 - 1) \quad (\text{C.1})$$

starting with

$$Q_0^{\text{con}}(w^2) = 1 \quad (\text{C.2})$$

$$Q_1^{\text{con}}(w^2) = -(5 - 6w^2) \quad (\text{C.3})$$

$$Q_2^{\text{con}}(w^2) = 15 - 14w^2(3 - 2w^2) \quad (\text{C.4})$$

$$T_m(w^2) = \left[(b(m) + c(m)w^2)T_{m-1}(w^2) - d(m)T_{m-2}(w^2) \right] / a(m) \quad (\text{C.5})$$

starting with

$$T_0(w^2) = 1 \quad (\text{C.6})$$

$$T_1(w^2) = 3w^2 - 2 \quad (\text{C.7})$$

These auxiliary polynomials have to be solved in the order given here and are valid for $m \geq 2$.

$$a(m) = 2m(m+4)(2m+2) \quad (\text{C.8})$$

$$b(m) = -32m - 48 \quad (\text{C.9})$$

$$c(m) = (2m+2)(2m+3)(2m+4) \quad (\text{C.10})$$

$$d(m) = 2(m-1)(m+3)(2m+4) \quad (\text{C.11})$$

Based on the recursion the first six Q s are the following:

$$Q_0^{\text{con}}(w^2) = 1$$

$$Q_1^{\text{con}}(w^2) = -(5 - 6w^2)$$

$$Q_2^{\text{con}}(w^2) = 15 - 14w^2(3 - 2w^2)$$

$$Q_3^{\text{con}}(w^2) = -(35 - 12w^2(14 - w^2(21 - 10w^2)))$$

$$Q_4^{\text{con}}(w^2) = 70 - 3w^2(168 - 5w^2(84 - 11w^2(8 - 3w^2)))$$

$$Q_5^{\text{con}}(w^2) = -(126 - w^2(1260 - 11w^2(420 - w^2(720 - 13w^2(45 - 14w^2))))))$$

Bibliography

- [1] ISO 4288, *Geometrical Product Specifications (GPS) — Surface texture: Profile method — Rules and procedures for the assessment of surface texture*
- [2] ISO 10110-19, *Optics and photonics — Preparation of drawings for optical elements and systems — Part 19: General description of surfaces and components*
- [3] FORBES G. W., "Robust, efficient computational methods for axially symmetric optical aspheres", *Opt. Express* **18**, 19700-19712 (2010)
- [4] FORBES G. W., "Asphere, O Asphere, how shall we describe thee?", *Proc. SPIE*, Vol. **7100**, 710002 (2008); DOI:10.1117/12.797770
- [5] KROSS J., OERTMANN F-W, SCHUHMANN R, "On Aspherics In Optical Systems", *Proc. SPIE*, Vol. 656, (1986)
- [6] FORBES G. W., "Shape specification for axially symmetric optical surfaces", *Opt. Express* **15**, 5218-5226 (2007) DOI: 10.1364/OE.15.005218
- [7] FORBES G. W., "Manufacturability estimates for optical aspheres", *Opt. Express* **19**, 9923-9942 (2011) DOI: 10.1364/OE.19.009923

[\(Continued from second cover\)](#)

<i>International Standard</i>	<i>Corresponding Indian Standard</i>	<i>Degree of Equivalence</i>
ISO 10110-1 Optics and photonics — Preparation of drawings for optical elements and systems — Part 1: General	IS 5920 (Part 1) : 2024/ISO 10110-1 : 2019 Optics and photonics — Preparation of drawings for optical elements and systems: Part 1 General	Identical
ISO 10110-5 Optics and photonics — Preparation of drawings for optical elements and systems — Part 5: Surface form tolerance	IS 5920 (Part 2) : 2024/ISO 10110-5 : 2015 Optics and photonics — Preparation of drawings for optical elements and systems: Part 2 Surface form tolerance	Identical
ISO 10110-6 Optics and photonics — Preparation of drawings for optical elements and systems — Part 6: Centring tolerances	IS 5920 (Part 3) : 2024/ISO 10110-6 : 2015 Optics and photonics — Preparation of drawings for optical elements and systems: Part 3 Centring tolerances	Identical
ISO 10110-7 Optics and photonics — Preparation of drawings for optical elements and systems — Part 7: Surface imperfections	IS 5920 (Part 4) : 2024/ISO 10110-7 : 2017 Optics and photonics — Preparation of drawings for optical elements and systems: Part 4 Surface imperfections	Identical
ISO 10110-8 Optics and photonics — Preparation of drawings for optical elements and systems — Part 8: Surface texture	IS 5920 (Part 5) : 2024/ISO 10110-8 : 2019 Optics and photonics — Preparation of drawings for optical elements and systems: Part 5 Surface texture	Identical

For the purpose of deciding whether a particular requirement of this standard is complied with, the final value, observed or calculated expressing the result of a test or analysis, shall be rounded off in accordance with IS 2 : 2022 'Rules for rounding off numerical values (*second revision*)'. The number of significant places retained in the rounded off value should be the same as that of the specified value in this standard.

Bureau of Indian Standards

BIS is a statutory institution established under the *Bureau of Indian Standards Act, 2016* to promote harmonious development of the activities of standardization, marking and quality certification of goods and attending to connected matters in the country.

Copyright

BIS has the copyright of all its publications. No part of these publications may be reproduced in any form without the prior permission in writing of BIS. This does not preclude the free use, in the course of implementing the standard, of necessary details, such as symbols and sizes, type or grade designations. Enquiries relating to copyright be addressed to the Head (Publication & Sales), BIS.

Review of Indian Standards

Amendments are issued to standards as the need arises on the basis of comments. Standards are also reviewed periodically; a standard along with amendments is reaffirmed when such review indicates that no changes are needed; if the review indicates that changes are needed, it is taken up for revision. Users of Indian Standards should ascertain that they are in possession of the latest amendments or edition by referring to the website-www.bis.gov.in or www.standardsbis.in.

This Indian Standard has been developed from Doc No.: PGD 39 (23508).

Amendments Issued Since Publication

Amend No.	Date of Issue	Text Affected

BUREAU OF INDIAN STANDARDS

Headquarters:

Manak Bhavan, 9 Bahadur Shah Zafar Marg, New Delhi 110002

Telephones: 2323 0131, 2323 3375, 2323 9402

Website: www.bis.gov.in

Regional Offices:

Central : 601/A, Konnectus Tower -1, 6th Floor,
DMRC Building, Bhavbhuti Marg, New
Delhi 110002

Telephones

{ 2323 7617

Eastern : 8th Floor, Plot No 7/7 & 7/8, CP Block, Sector V,
Salt Lake, Kolkata, West Bengal 700091

{ 2367 0012
{ 2320 9474

Northern : Plot No. 4-A, Sector 27-B, Madhya Marg,
Chandigarh 160019

{ 265 9930

Southern : C.I.T. Campus, IV Cross Road, Taramani, Chennai 600113

{ 2254 1442
{ 2254 1216

Western : 5th Floor/MTNL CETTM, Technology Street, Hiranandani Gardens, Powai
Mumbai 400076

{ 25700030
{ 25702715

Branches : AHMEDABAD, BENGALURU, BHOPAL, BHUBANESHWAR, CHANDIGARH, CHENNAI, COIMBATORE, DEHRADUN, DELHI, FARIDABAD, GHAZIABAD, GUWAHATI, HARYANA (CHANDIGARH), HUBLI, HYDERABAD, JAIPUR, JAMMU, JAMSHEDPUR, KOCHI, KOLKATA, LUCKNOW, MADURAI, MUMBAI, NAGPUR, NOIDA, PARWANOO, PATNA, PUNE, RAIPUR, RAJKOT, SURAT, VIJAYAWADA.