

यांत्रिक कंपन — सक्रिय चुंबकीय बियरिंग से  
युक्त घूर्णन मशीनरी का कंपन

भाग 5 टच-डाउन बियरिंग



**Mechanical Vibration — Vibration of  
Rotating Machinery Equipped with  
Active Magnetic Bearings**

**Part 5 Touch-Down Bearings**

ICS 17.160

© BIS 2024

© ISO 2022



भारतीय मानक ब्यूरो  
BUREAU OF INDIAN STANDARDS  
मानक भवन, 9 बहादुर शाह ज़फर मार्ग, नई दिल्ली - 110002  
MANAK BHAVAN, 9 BAHADUR SHAH ZAFAR MARG  
NEW DELHI - 110002

[www.bis.gov.in](http://www.bis.gov.in) [www.standardsbis.in](http://www.standardsbis.in)

## NATIONAL FOREWORD

This Indian Standard which is identical to ISO 14839-5 : 2022 'Mechanical vibration — Vibration of rotating machinery equipped with active magnetic bearings — Part 5: Touch-down bearings' issued by the International Organization for Standardization (ISO) was adopted by the Bureau of Indian Standards on the recommendation of the Bearings Sectional Committee and after approval of the Production and General Engineering Division Council.

This standard is published in five parts. Other parts in this series are:

- Part 1      Vocabulary
- Part 2      Evaluation of vibration
- Part 3      Evaluation of stability margin
- Part 4      Technical guidelines

The text of ISO standard has been approved as suitable for publication as an Indian Standard without deviations. Certain conventions are, however, not identical to those used in Indian Standards. Attention is particularly drawn to the following:

- a) Wherever the words 'International Standard' appear referring to this standard, they should be read as 'Indian Standard'; and
- b) Comma (,) has been used as a decimal marker while in Indian Standards, the current practice is to use a point (.) as the decimal marker.

In this adopted standard, reference appears to the following International Standards for which Indian Standards also exists. The corresponding Indian Standards which is to be substituted in its place is listed below along with its degree of equivalence for the edition indicated.

<i>International Standards</i>	<i>Corresponding Indian Standards</i>	<i>Degree of Equivalence</i>
ISO 2041 Mechanical vibration, shock and condition monitoring — Vocabulary	IS/ISO 2041 : 2018 Mechanical vibration, shock and condition monitoring — Vocabulary ( <i>first revision</i> )	Identical
ISO 14839-1 Mechanical vibration — Vibration of rotating machinery equipped with active magnetic bearings Part 1: Vocabulary	IS 18920 (Part 1) : 2024/ISO 14839-1 : 2018 Mechanical vibration — Vibration of rotating machinery equipped with active magnetic bearings: Part 1 Vocabulary	Identical



# Contents

Page

<b>1</b>	<b>Scope</b> .....	<b>1</b>
<b>2</b>	<b>Normative references</b> .....	<b>2</b>
<b>3</b>	<b>Terms and definitions</b> .....	<b>2</b>
<b>4</b>	<b>General structure and components</b> .....	<b>2</b>
<b>5</b>	<b>Functional targets</b> .....	<b>4</b>
	5.1 General.....	4
	5.2 Design life.....	6
	5.3 Clearance requirements.....	6
	5.4 Life-cycle requirements.....	6
<b>6</b>	<b>Touch-down bearing design considerations</b> .....	<b>7</b>
	6.1 General.....	7
	6.2 Trigger events.....	7
	6.2.1 Overload due to abnormal process conditions.....	7
	6.2.2 AMB control instability.....	8
	6.2.3 Loss of power.....	9
	6.2.4 Failure in the AMB system.....	10
	6.2.5 Misoperation.....	10
	6.3 Transportation duty.....	10
	6.3.1 General.....	10
	6.3.2 AMBs without permanent magnets.....	11
	6.3.3 AMBs with permanent magnets.....	11
	6.4 Failure modes.....	12
	6.4.1 General.....	12
	6.4.2 Rolling element failure modes.....	12
	6.4.3 Sliding bearing failure modes.....	13
	6.5 Environmental factors.....	13
	6.5.1 General.....	13
	6.5.2 Corrosion resistance.....	13
	6.5.3 Erosion resistance, particulate contamination.....	14
	6.5.4 Liquid contamination.....	14
	6.5.5 Operating temperature.....	14
	6.5.6 Available cooling flow.....	14
	6.6 Rotordynamic modelling considerations.....	14
	6.6.1 General.....	14
	6.6.2 Rotor and housing modelling requirements.....	14
	6.6.3 Touch-down bearing soft mount design considerations.....	16
	6.6.4 Touch-down bearing clearance design considerations.....	16
	6.6.5 Friction between the rotor and touch-down bearing design considerations.....	16
	6.7 Contact classification/severity.....	17
	6.7.1 Contact duration.....	17
	6.7.2 Types of motion.....	17
	6.8 Control actions following touch-down bearing contact.....	19
	6.8.1 General.....	19
	6.8.2 AMB controller action.....	19
	6.8.3 Plant/variable-frequency drive control actions.....	19
<b>7</b>	<b>Design and design verification</b> .....	<b>19</b>
	7.1 General.....	19
	7.2 Design process details.....	20
	7.3 Documentation.....	30
<b>8</b>	<b>Condition monitoring and damage estimation methods</b> .....	<b>30</b>
	8.1 General.....	30

8.2	Event detection and data capture .....	30
8.2.1	Contact detection.....	30
8.2.2	Contact event.....	30
8.3	Inspection .....	31
8.3.1	General.....	31
8.3.2	Common techniques in non-intrusive inspection.....	31
8.3.3	Intrusive inspection.....	32
8.4	Damage estimation.....	34
8.4.1	Event data.....	34
8.4.2	Inspection-based estimation.....	35
8.4.3	Criteria for further operation.....	36
<b>9</b>	<b>Maintenance and life cycle factors.....</b>	<b>37</b>
9.1	General.....	37
9.2	Inspection plan.....	37
9.2.1	General.....	37
9.2.2	Minimum intervention cycle.....	37
9.3	Interventions.....	37
9.3.1	Routine checks.....	37
9.3.2	Predicted excessive damage accumulation.....	38
9.3.3	Contamination.....	39
9.4	Maintenance actions.....	39
9.4.1	General.....	39
9.4.2	Touch-down-bearing refurbishment.....	39
9.4.3	Touch-down bearing replacement.....	40
9.5	Life-cycle factors.....	41
9.5.1	General.....	41
9.5.2	Spare part management.....	41
9.5.3	Decommissioning, recycling and disposal.....	42
9.5.4	Obsolescence management.....	42
	<b>Bibliography.....</b>	<b>43</b>

*Indian Standard*

# MECHANICAL VIBRATION — VIBRATION OF ROTATING MACHINERY EQUIPPED WITH ACTIVE MAGNETIC BEARINGS

## PART 5 TOUCH-DOWN BEARINGS

### 1 Scope

This document gives guidelines for identifying:

- a) The typical architectures of touch-down bearing systems to show which components are likely to comprise such systems and which functions these components provide;

NOTE Touch-down bearings are also known as “backup bearings”, “auxiliary bearings”, “catcher bearings” or “landing bearings”. Within this document, the term “touch-down bearings” is used exclusively as defined in ISO 14839-1.

- b) The functional requirements for touch-down bearing systems so that clear performance targets can be set;
- c) Elements to be considered in the design of the dynamic system such that rotordynamic performance can be optimized, both for touch-down bearings and active magnetic bearings (AMBs);
- d) The environmental factors that have significant impact on touch-down bearing system performance allowing optimization of overall machine design;
- e) The AMB operational conditions that can give rise to contact within the touch-down bearing system so that such events can be considered as part of an overall machine design. It also considers failure modes within the AMB system that can give rise to a contact event. This ensures that the specification of the touch-down bearings covers all operational requirements;
- f) The most commonly encountered touch-down bearing failure modes and typical mechanisms for managing these events;
- g) Typical elements of a design process for touch-down bearing systems including the specification of load requirements, the sizing process, the analytical and simulation methods employed for design validation;
- h) The parameters to be taken into account when designing a touch-down bearing system acceptance test programme including the test conditions to be specified and the associated instrumentation to be used to ensure successful test execution;
- i) The condition monitoring and inspection methods that allow the status of in-service touch-down bearings to be evaluated and when necessary identifying the corrective actions to be taken;
- j) The factors to be considered when designing the maintenance regime for a touch-down bearing system including the actions to be taken after specified events have occurred together with any actions to be performed on a regular basis;
- k) The factors to be considered regarding other life cycle topics (e.g. obsolescence management, de-commissioning and disposal).

## 2 Normative references

The following documents are referred to in the text in such a way that some or all of their content constitutes requirements of this document. For dated references, only the edition cited applies. For undated references, the latest edition of the referenced document (including any amendments) applies.

ISO 2041, *Mechanical vibration, shock and condition monitoring — Vocabulary*

ISO 14839-1, *Mechanical vibration — Vibration of rotating machinery equipped with active magnetic bearings — Part 1: Vocabulary*

## 3 Terms and definitions

For the purposes of this document, the terms and definitions given in ISO 2041 and ISO 14839-1 apply.

ISO and IEC maintain terminological databases for use in standardization at the following addresses:

- ISO Online browsing platform: available at <https://www.iso.org/obp>
- IEC Electropedia: available at <https://www.electropedia.org/>

## 4 General structure and components

Rotating machinery equipped with AMBs is typically also equipped with touch-down bearings. These touch-down bearings are intended to support the rotor when the AMB system is not activated or during a failure or overload of the AMB system. In these instances, the touch-down bearings are required to support the rotor until either levitation is recovered or the rotor is brought to zero rotational speed without damaging to other parts of the machine.

During normal operation of the machinery, the touch-down bearings have a clearance with the rotor and consequently do not apply force. The clearance at the touch-down bearings is typically the closest clearance within the rotating machine. This ensures in the event of a problem with the AMB, when the rotor moves away from its normal “centred” operating position, the first item to make contact between the rotor and stator is the touch-down bearing. Such an event occurring during rotation is referred to as a “touch-down event”, “landing event”, “contact event” or “drop event”. Such events have historically been categorized by some vendors as either “hard” landings, where a full de-levitation from high speed occurs or “soft” landings where either a partial de-levitation or a momentary contact occurs.

Touch-down bearings are required to constrain rotor movement in the degrees of freedom normally constrained by the AMB system. In the case of a rotor with two radial AMBs and one axial AMB, the touch-down bearings are required to constrain the associated five axes of movement. This is typically achieved by using:

- a) two radial touch-down bearings with a separate axial touch-down bearing;
- b) two radial touch-down bearings, each with a single acting thrust face; or
- c) one radial touch-down bearing with a combined radial/axial touch-down bearing.

Touch-down bearings use a range of technologies, such as:

- d) stator mounted rolling element bearings;
- e) rotor mounted rolling element bearings;
- f) dry lubricated plain bushings;
- g) dry lubricated pad construction;
- h) foil bearings;

- i) aero-static bearings;
- j) fluid-film bearings; and
- k) hybrids of technologies d) to j).

In most instances on large machines the touch-down bearing comprises of a rotor part (commonly referred to as a landing sleeve) together with a stator part. The landing sleeve is intended to ensure that no damage to the core shaft occurs on touch-down and typically is a replaceable item. An alternative to the landing sleeve is to land directly on the shaft surface, which has a wear resistant coating or treatment.

The stator part typically comprises a low-friction element, which contacts the landing surface and is supported by a compliant element. The compliant element has an associated stiffness and damping which is intended to improve vibration response during a touch-down event.

The compliant element can have these characteristics:

- l) preload;
- m) stiffness;
- n) damping;
- o) touch-down bearing hard-stop clearance.

When considering the minimum design clearance at any axial location, the total rotor motion at the touch-down bearings, which includes the clearance and the touch-down bearing hard-stop clearance, shall be considered together with other system stiffnesses and tolerances/concentricities. This is discussed in [Clause 6](#).

Schematic drawings of typical configurations are shown in [Figure 1](#) and [Figure 2](#).

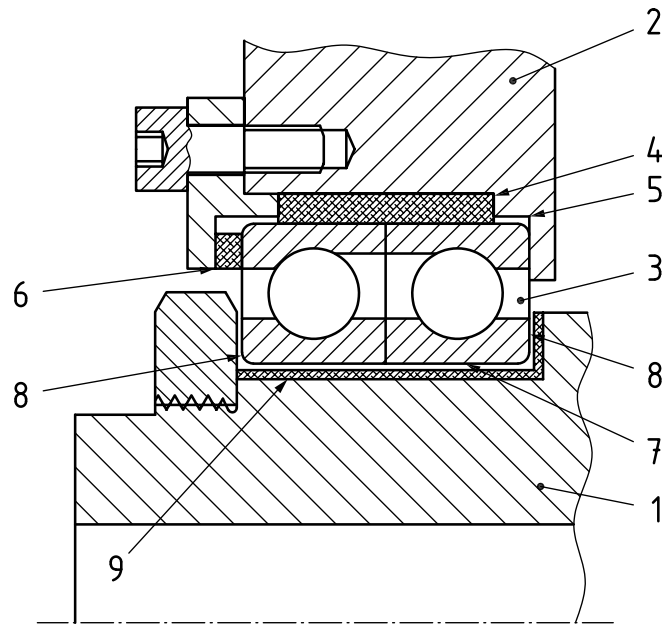

**Key**

- |   |                            |   |                              |
|---|----------------------------|---|------------------------------|
| 1 | core shaft                 | 6 | preload spring               |
| 2 | touch-down bearing housing | 7 | radial clearance             |
| 3 | rolling element bearing    | 8 | axial clearance              |
| 4 | compliant element          | 9 | landing surfaces (or sleeve) |
| 5 | hard stop clearance        |   |                              |

**Figure 1 — A typical configuration for a rolling element touch-down bearing installation**

For dry bush type radial touch-down bearings as depicted in [Figure 2](#), the landing surface may be either a cylindrical bush (which moves as a single entity) or by articulated pads which are able to move independently of each other. In both cases the moving element(s) are supported by one or more compliant elements which provide both stiffness and damping within the hard stop clearance. In the case of the pad arrangement, the compliant elements also provide a defined pre-load force. In both cases the material of the landing surface may be optionally bonded to a backing material with suitable mechanical properties.

The condition of the touch-down bearings can be of utmost importance in case of an AMB failure. The touch-down bearings shall be able to safely bear the rotor during an event such as momentary contact or a full rundown to standstill. The stringent operational demands, such as high acceleration rates and high forces, lead to a very limited number of such events being allowed, thus the touch-down bearings are considered consumable parts. However, replacing touch-down bearings which have not yet reached the end of their lifetime should be avoided. Therefore, condition monitoring of touch-down bearings is essential.

## 5 Functional targets

### 5.1 General

This clause introduces the functional requirements for a touch-down bearing system that would typically be communicated by a customer of such systems to the vendor. These requirements comprise the conditions under which the touch-down bearing system shall operate, the limits to rotor excursion that the touch-down bearing shall protect, and the lifetime that the touch-down bearing shall sustain.



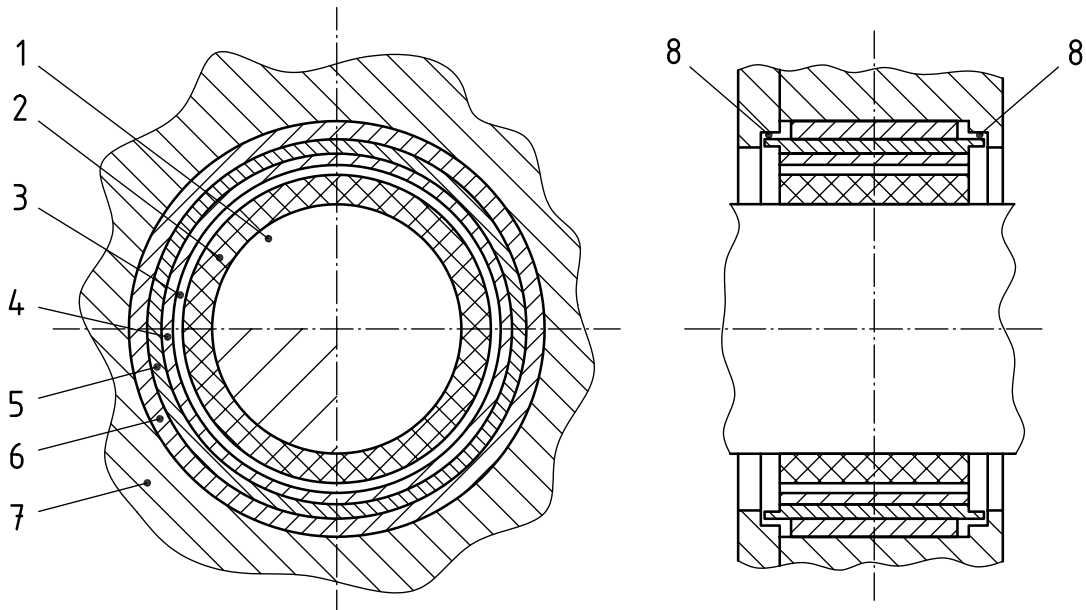

a) Radial bushing

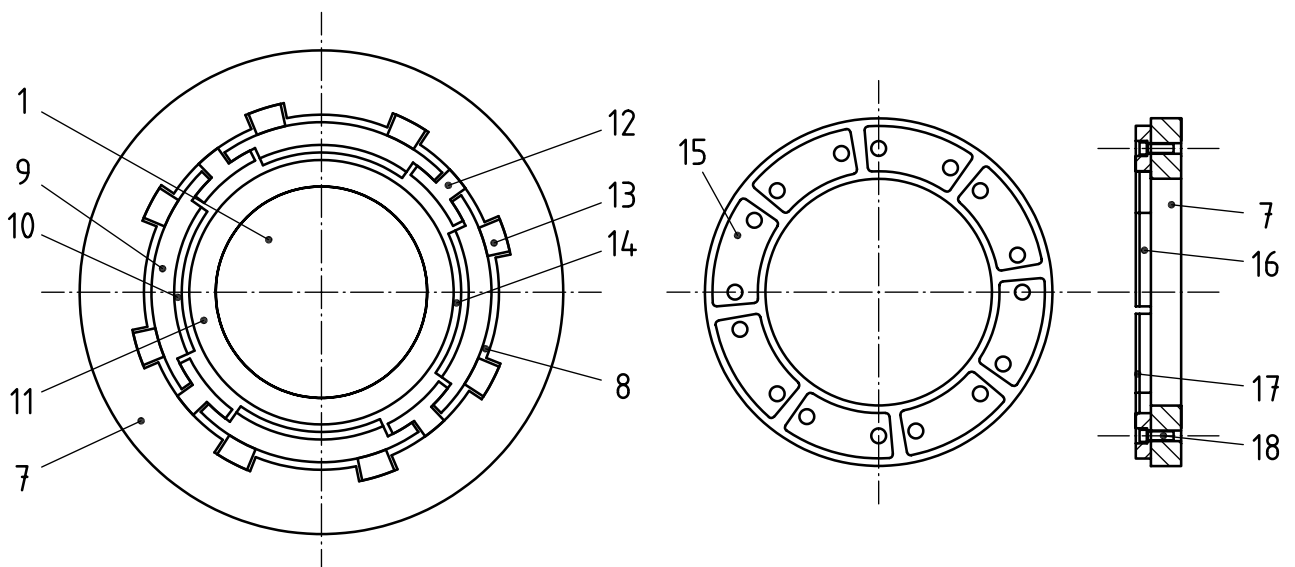

b) Radial articulated pads

c) Axial fixed pads

**Key**

- |   |                                    |    |                                   |
|---|------------------------------------|----|-----------------------------------|
| 1 | core shaft                         | 10 | articulated pad (landing surface) |
| 2 | landing sleeve (optional)          | 11 | rotor landing sleeve              |
| 3 | air gap                            | 12 | pad stop                          |
| 4 | bush landing surface               | 13 | compliant element with preload    |
| 5 | bush backing material (optional)   | 14 | rotor stator clearance            |
| 6 | compliant element                  | 15 | fixed pad                         |
| 7 | touch-down bearing housing         | 16 | pad backing material              |
| 8 | hard stop clearance                | 17 | pad landing surface               |
| 9 | articulated pad (backing material) | 18 | fixing screw                      |

**Figure 2 — Typical configurations for dry bush touch-down bearings**

## 5.2 Design life

Touch-down bearing design life requirements shall be agreed between the customer and vendor prior to project execution and specific requirements can vary depending on the application. The touch-down bearing system shall be designed to handle a minimum number of contact events without requiring replacement or refurbishment. The agreed upon minimum number of contact events shall consider both transient contact events (momentary contacts) and sustained contact events (rundowns) and the maximum time period over which this capacity shall be sustained (effective service life of the touch-down bearing).

Additional factors that can affect touch-down bearing design life requirements include, but are not limited to:

- a) the likelihood of abnormal process conditions;
- b) hazardous environmental risks;
- c) availability of a braking system (for sustained shutdown events);
- d) power grid reliability;
- e) the availability of uninterruptible power supplies (UPS) for backup power;
- f) machine availability requirements (see [6.2](#)).

It is important to recognize that the viability of the touch-down bearing can degrade over time due to environmental factors even if no hard or soft landings occur.

A means shall be provided to estimate the status of the in-service touch-down bearing system in relation to the design life requirements, without requiring a shutdown to perform the evaluation, see [8.3](#).

## 5.3 Clearance requirements

Permitted maximum motions within a machine depend on other close clearances within it (e.g. those in labyrinth seals). The touch-down bearings are required to limit the motions to ensure there is no unintended contact when running on the touch-down bearings.

Clearance control within the touch-down bearing will yield a maximum clearance requirement for it. This ensures that there will be no unintended contact with other parts of the machine when operating on the touch-down bearings. Clearance will depend on the assembly and manufacturing tolerances within the complete rotor and stator assembly, differential thermal effects, load cases, and other application specific forces and shall take account of the rotordynamic response when running on the touch-down bearings and during transient events.

Permitted minimum clearances in the touch-down bearing will ensure no un-intended contact with the touch-down bearing occur when the AMB is operating under specified conditions. This depends on the manufacturing concentricity tolerances of the rotor within the machine together with the nominal clearances at other locations within it. Lifetime factors such as contamination, differential thermal effects and other application specific forces need to be considered and taken into account.

Where lifetime factors are known to the machine designer, they shall be communicated to the AMB/touch-down bearing vendor as part of the AMB functional requirements.

## 5.4 Life-cycle requirements

The touch-down bearing system shall require inspection or replacement if the accumulated damage approaches or exceeds the design life requirements. The requirement for inspection or replacement shall be evaluated if the touch-down bearing system is operated outside its intended design requirements, especially for an extended period of time.

Following inspection, the touch-down bearing system can require maintenance, which can include refurbishment or replacement depending on the priorities at hand and spare parts will typically be available in advance to minimize machine downtime. The vendor shall maintain a source of touch-down bearing spare parts for an agreed period.

## **6 Touch-down bearing design considerations**

### **6.1 General**

This clause gives an overview of those items to be considered during the design of the touch-down bearing system by the AMB/touch-down bearing vendor and is intended to support the transformation of functional requirements into design requirements. Many requirements can be derived directly from the functional requirements where such information is known by the machine designer, but in many instances they need either to be synthesized by the vendor from the functional requirements or where this information is not known by the machine designer, estimated by the vendor based on prior experience. Touch-down bearings are included in AMB systems to provide backup or auxiliary rotor support in the rare situations where the AMBs cannot completely control the rotor. These rare situations are referred to as trigger events and are described in [6.2](#).

### **6.2 Trigger events**

#### **6.2.1 Overload due to abnormal process conditions**

##### **6.2.1.1 General**

AMBs have a limited peak load capability characterized by saturation in their ferromagnetic pole pieces. When loaded beyond saturation, the rotor falls out of support and needs to be retained by the touch-down bearings to prevent damage to the machine. Overload can be due to an abnormal process condition occurring or unexpected external loading source. In many cases, design margins can be included in the AMB sizing to provide extra capacity for such events; however, it is important to avoid providing substantial unneeded capacity in the AMB system. Oversized magnetic bearings can lead to poor actuator bandwidth, undesirable rotordynamic characteristics, and less robust control. Some common sources of overloading force are mentioned in [6.2.1.2](#) to [6.2.1.8](#).

##### **6.2.1.2 Compressor surge**

Although compressor surge is reasonably well understood, when it occurs, the affect on the AMB control system of the amplitude of the imposed load, its excitation frequency and frequency of occurrence is difficult to predict and depends on factors that are not always in the machine designer's control. In some cases, surge results in short-term or intermittent contact with the touch-down bearings (also called touch-and-go) followed by recovery to continuous operation on the AMBs.

##### **6.2.1.3 Shock from seismic events, explosions or external impacts**

These events are difficult to predict and can vary widely in magnitude and bandwidth. An AMB system can be designed to meet specific seismic requirements, but seismic events beyond the design requirements usually result in touch-down bearing impact. Occasionally, AMB systems are subjected to large shocks (e.g. resulting from explosions or external impacts), which are generally expected to be absorbed by the touch-down bearings.

If a shock load event is expected during the system lifetime, its amplitude and duration shall be defined in order that it can properly be taken account of in the AMB design analysis.

#### **6.2.1.4 Sudden rotor unbalance due to the loss of solids built-up during process flows**

Some turbomachinery processes result in a build-up of solid matter on rotor surfaces. Portions of this build-up can flake off during operation resulting in a sudden unbalance. Often the resulting unbalance is small enough to be acceptable for steady-state operation of the AMB, but the impulse created can produce a short-term or intermittent contact on the touch-down bearings.

#### **6.2.1.5 Sudden rotor unbalance from loss of a turbine blade or other partial failure**

A failure of this type usually results in an unbalance load that is well beyond the capability of the AMB system to tolerate and thus results in a substantial initial impact load being applied to the touch-down bearings, followed by a full-speed spin down onto the touch-down bearings. For some types of machine, a blade out failure is a design load requirement for the touch-down bearings.

#### **6.2.1.6 Abnormal motor loads – phase unbalance**

For machines driven by electric motors, a phase unbalance can result in a radial load on the rotor that does not exist in normal operation. Sudden loss of a phase during operation can result in an impulse load that overloads the AMBs, resulting in touch-down bearing contact.

#### **6.2.1.7 Rub at machine close clearance**

In a machine with an AMB control system, the touch-down bearing clearance shall be set such that any excursion of the rotor from its rotational axis centre shall result in touch-down bearing contact before touching any other stator element not intended to wear. Efficiency requirements in turbomachinery encourage seal clearances to be set at minimal levels in many machine designs. However, unintended rubbing contact with a seal can occur when the AMB system design has not allowed for adequate clearance margin or seal concentricity relative to the touch-down bearing. Abradable seals are designed for such contact and their use is permitted.

#### **6.2.1.8 Liquid slugging**

In some processes, a slug of liquid can be introduced in the machine causing a shock or impulse load that results in touch-down bearing contact.

### **6.2.2 AMB control instability**

#### **6.2.2.1 General**

The nature of AMB compensator design is such that there often are frequency bands or operating scenarios where the AMB forces produce negative damping for one or more natural vibration modes of the rotor/AMB/housing system. AMB design to avoid instabilities is covered in ISO 14839-3.

#### **6.2.2.2 Inadequate control robustness to allow for process variation**

Inadequate AMB control robustness can arise from a range of process variations that generate destabilizing forces, such as:

- a) fluid dynamic forces in compressors, turbines and labyrinth seals can be destabilizing under certain conditions (often characterized by cross-coupled stiffness);
- b) forces that are not adequately specified for the defined control scheme could not have the necessary stability margin to keep one or more modes stable under all operating conditions;
- c) process fluid density much higher than predicted can result in higher destabilizing forces;
- d) variation in suction pressure results in higher destabilizing forces.

### **6.2.2.3 Lack of slew rate margin to control the dynamic loads**

To respond to dynamic loads an AMB has to produce a certain control current at a required frequency. As the frequency increases, the required voltage to push the desired current through, the control increases. Since power amplifiers are sized with some specific overhead (or bus) voltage, the voltage demand of a particular load can exceed the available overhead. In this case the current is limited by the maximum  $di/dt$  or current slew rate. This situation almost always leads to touch-down bearing contact.

### **6.2.2.4 Lack of power supply capacity to control the axial dynamic loads**

AMBs generally impose very low real power requirements compared to other types of bearings. Additionally, in most cases it is straightforward to provide an adequately sized power supply. However, if process conditions impose unexpected axial dynamic loads, the AMB power requirements can exceed the design case due to the difficulty in predicting eddy current losses (which use real power) in the thrust bearing.

### **6.2.2.5 Operation of a machine outside of its design case speed range**

In highly gyroscopic machines, such as those with single overhung impellers, the AMB control may be gain scheduled. In this case the AMB control is adjusted based on spin speed. If the machine is operated above the design speed one or more rotor vibration modes can become unstable, resulting in touch-down bearing contact.

### **6.2.2.6 Unexpected machine acceleration/deceleration profile**

During excessive acceleration/deceleration, fluid dynamic forces can be much larger than designed for.

## **6.2.3 Loss of power**

### **6.2.3.1 General**

AMB systems require an electrical power source to operate. Loss of electrical power results in deactivation of the amplifiers and shutdown of the control system. If this happens, the rotor drops onto the touch-down bearings. Generally, some type of backup electrical power is included as part of the AMB control system design, so that the AMBs will operate to allow safe spin down when external power is lost.

### **6.2.3.2 AMB systems with no backup power source**

If no backup electrical power source is provided, a loss of power results in a rotor drop onto the touch-down bearings at speed.

### **6.2.3.3 System with an uninterruptable power supply (UPS)**

Many AMB systems have a UPS sized to allow spin down of the AMBs in the event of power loss. In these systems, power loss should not be an issue unless there is a defect or failure of the UPS.

### **6.2.3.4 Systems that incorporate a motor/generator having a regenerative backup system**

Such a system can generate enough electrical power to supply the AMB in the event of power loss; however, the electrical power generator can drop out below a certain speed, often 20 % to 25 % of maximum speed. Such systems generally have a relatively benign low-speed drop (e.g. without incurring measurable system damage) as part of a system power loss event.

## 6.2.4 Failure in the AMB system

### 6.2.4.1 General

Failure in some part of the AMB system generally results in a drop and spin down on the touch-down bearings. Depending on the action taken by the controller, this can be a drop of one or more axes up to and including a full machine drop followed by a spin down request from the magnetic bearing controller (MBC).

### 6.2.4.2 MBC component fault

Failure of the MBC power supply or a component or sub-system failure that stops the control program always results in a five-axis drop. Other component failures generally result in loss of control on one or more axes, followed by either a full or partial drop – depending on the control action taken.

### 6.2.4.3 Actuator or actuator cable failure

An actuator short or open circuit results in the inability to apply a reaction force to the rotor. This results in a loss of control and is detected as an excess displacement, excess control current, or low power supply voltage and results in a drop.

### 6.2.4.4 Transducer or transducer cable failure

A transducer failure can result in an undesirable control action that applies the full force of the AMB to push the rotor onto the touch-down bearings, adding an additional impact and static load to the touch-down bearing loading.

## 6.2.5 Misoperation

Misoperation of the system occurs when:

- a) the process flow spins the rotor while the AMB is shut down, which results in the rotor running on the touch-down bearings, possibly for some time;
- b) there are operator or maintenance errors, such as:
  - i) input power turned off;
  - ii) cables become disconnected during operation;
  - iii) accidental cutting of cables during operation;
  - iv) incorrect installation of the touch-down bearings.
- c) the system is sabotaged.

## 6.3 Transportation duty

### 6.3.1 General

The touch-down bearings may or may not provide adequate support to the rotor during transportation. Where the rotor is not locked by other means this shall be addressed.

When a machine has its AMB control system turned off, the rotor is typically free to move throughout the clearance defined by the touch-down bearings. This behaviour depends on whether the AMBs incorporate permanent magnets.

Standards for testing response to mechanical shock, and vibration due to transport can be found in

- a) ASTM D6344,



- b) ISO 2244, and
- c) ISO 13355.

Importantly, these standards include power spectral density data for typical shipping scenarios, so they provide a basis for the evaluation of possible damage to the rotor or touch-down bearings during transport.

In addition to mechanical shock considerations, transport can expose AMB equipment to corrosive or abrasive environments unless they are sealed adequately.

### **6.3.2 AMBs without permanent magnets**

In AMBs without permanent magnets, the rotor is free to move throughout the touch-down bearing clearance when the AMB is not activated. This freedom to move can result in damage to the rotor or to the touch-down bearings during transport or other events with high vibration levels (e.g. earthquakes).

The touch-down bearings are intended to prevent damage to the rotor and to themselves in the event of an overload or loss of control by the AMBs so, in some sense, the transport or earthquake condition is similar to these anticipated operating events. As such, assessment of potential touch-down bearing damage due to transport or earthquakes can take the same approach as is outlined in [6.7](#) with the exception that the rotor is assumed to not be rotating when it makes contact with the touch-down bearings. This lack of rotation means that touches are less likely to be distributed over the working contact surfaces of the touch-down bearing and rotor and can instead, repeatedly contact at the same point. This shall be considered in evaluating any potential damage.

AMB equipped machines are sometimes shipped dismantled so that the rotor is separate and fully restrained. In such cases, there is no particular concern about impact damage to the rotor or touch-down bearings. For machines which are shipped fully or partially assembled, potential damage to the rotor or touch-down bearings shall be considered.

Where damage during transportation or any other event is thought possible, a locking device shall be provided to restrain the rotor. A locking device fixes the position of the rotor radially and axially and as a result, any potential damage by bouncing is minimized. In the simplest case, the rotor lying on the touch-down bearings is braced against the machine casing. Permanent static stress on the touch-down bearings plus potential external shocks during transportation can be critical, especially with heavy rotors. Therefore, more advanced solutions aim at centering the rotor within the touch-down bearing clearance so that, ideally, it no longer contacts the touch-down bearings. Any type of transport lock shall be removed before commissioning the machine.

If a machine with AMBs is subjected to transportation without means to restrain the rotor and prevent contact with the touch-down bearings or it is subjected to an earthquake shock, then the condition of the touch-down bearing shall be evaluated after the shock event following the nonintrusive inspection procedures of [8.3.2](#) unless shock monitoring instrumentation has been installed on the machine and indicates the level of shock is within specification.

### **6.3.3 AMBs with permanent magnets**

For machines using permanent magnetic biased AMBs or a permanent magnetic motor/generator, the magnets produce passive radial and axial forces that pull the rotor against the touch-down bearings. As a result, when the AMBs in these machines are deactivated, they can sustain higher levels of transport or earthquake motion before the rotor can bounce in the clearance space and cause repeated impacts on the touch-down bearings. For such equipment, it is not necessary to evaluate potential damage to the rotor or touch-down bearings as long as the maximum casing acceleration is limited to a level below the ratio of contact pre-load of the touch-down bearings to rotor mass. If maximum casing acceleration exceeds this level, assessment of potential damage shall follow the procedure described in [6.3.2](#) for AMB supported machines without permanent magnets.

## 6.4 Failure modes

### 6.4.1 General

The touch-down bearings shall survive the specified contact events without failure. Examples of direct or subsequent failure mechanisms which can occur are:

- a) accumulated wear due to normal touch-down bearing operation leading to subsequent failure;
- b) yielding due to excessive load;
- c) fatigue failure due to excessive stress cycles;
- d) excessive temperature resulting in welding or loss of material due to material reaching its melting point;
- e) excessive temperature resulting in a change of material properties (e.g. heat treatment) leading to subsequent failure;
- f) wear due to contamination or lubrication failure;
- g) corrosion;
- h) seizure due to thermal growth and loss of clearance;
- i) loss of landing sleeve interference fit;
- j) damage to a compliant mount;
- k) undetected contact leading to subsequent failure.

Other failure modes which can be eliminated by design are associated with stress limits in both the rotor and stator parts. Touch-down bearing design shall ensure that all rotor and stator parts are below yield at the maximum specified load as determined by the rotordynamics analysis of [6.6](#). The rotor analysis shall take into account the shrink fit with which they are likely to be fitted to the shaft together with the stress cycling associated with each machine start/stop cycle. Inadequate design can lead to low-cycle fatigue failure.

The effect of corrosive contaminants and their associated pH levels shall be taken into account at the design stage, otherwise they can lead to premature failure of the touch-down bearings due to stress corrosion cracking. In these cases suitably qualified corrosion resistant materials shall be used.

Chemical contaminants (e.g. hydrogen or mercury) that can lead to embrittlement limit the choice of materials for the rotor.

Failure mechanisms specific to each type of touch-down bearing are identified in [6.4.2](#) and [6.4.3](#).

### 6.4.2 Rolling element failure modes

Failure mechanisms applicable to rolling element touch-down bearings include, but are not limited to:

- a) windmilling, which can result in wear when an unloaded touch-down bearing spins continuously due to gas flow through it;
- b) fretting, which can result in wear due to repeated micro-slippage between fitting surfaces and in the contact zones between a raceway and rolling elements;
- c) brinelling, in which repeated impacts or static overload cause localized indentations in a bearing raceway due to plastic deformation;
- d) skidding, in which high angular acceleration of a raceway can cause gross sliding of the rolling elements due to inertia forces exceeding the contact forces required to maintain rolling traction;



- e) cage failure.

### 6.4.3 Sliding bearing failure modes

The primary failure mode for sliding bearing type touch-down bearings is wear of the dry lubricated bush material. During each contact event wear of the dry bush material occurs. Eventually after multiple contact events the clearance in the touch-down bearings exceeds a pre-defined limit which is necessary to protect the other clearances within the machine. In normal service, touch-down bearing wear is predictable and repeatable and can be remotely inspected by performing a clearance check.

The amount of wear that occurs during each contact event depends on:

- a) the applied load;
  - b) the margin between the material peak surface temperature and its normal operating temperature;
  - c) the contact duration.
- b) and c) depend on the braking torque available to bring the rotor to zero speed (e.g. fluid dynamic load, regenerative braking). The peak surface temperatures also depend on the applied load and the design of the touch-down bearing stator and rotor.

Aggressively abrasive contaminants (e.g. sand) may be tolerated if appropriate material selections are made, but they shall also be factored into the design, otherwise excessive wear of the pad material and/or damage to the rotor sleeve can occur during contact.

## 6.5 Environmental factors

### 6.5.1 General

This clause addresses:

- a) corrosion resistance;
- b) erosion resistance;
- c) particulate contamination;
- d) liquid contamination;
- e) operating temperature;
- f) available cooling flow.

Environmental factors to be taken into account in designing an AMB are discussed in ISO 14839-2 and in addition, touch-down bearings are expected to survive the conditions outlined there while meeting the functional targets. The requirements set out in [6.5.2](#) to [6.5.6](#) do not supersede those in ISO 21940 (all parts) but are intended to highlight the considerations to be taken into account that are specific to touch-down bearings.

### 6.5.2 Corrosion resistance

When touch-down bearings are exposed to corrosive environments, this can lead to surface damage of rolling elements, inner races, and outer races in rolling-element type touch-down bearings or to inner and outer contact surfaces in bushing type touch-down bearings. Additionally, the compliant elements are also likely to be sensitive to corrosive environments. This damage will lead to increased friction in the event of a contact of the touch-down bearing and, consequently, degraded performance and degraded service life. Therefore, it is important that any surface of a touch-down bearing exposed to a corrosive environment is chemically compatible with it as to limit corrosive damage.

### 6.5.3 Erosion resistance, particulate contamination

When touch-down bearings are exposed to environments containing erosive materials or particulates, this can lead to damage to surfaces of rolling elements, inner races, and outer races in rolling-element type touch-down bearings or to inner and outer contact surfaces in bushing type touch-down bearings. This damage will lead to increased friction in the event of a contact of the touch-down bearing and, consequently, degraded performance and degraded service life. Therefore, it is important to take measures to prevent the ingress of erosive agents or other particulates into the touch-down bearings. Where it is not possible to prevent the ingress of particulate contamination, inspection plans, that establish the level of damage present, shall be defined in order to allow the touch-down bearings to be changed before failure (see [9.2](#) and [9.3](#)).

### 6.5.4 Liquid contamination

Liquid contamination of touch-down bearings will alter the micro-mechanical interaction of surfaces meant to roll or slide against one another. If the touch-down bearings use either a wet or dry lubricant, liquid contamination can degrade the effectiveness of such lubricants. The potential impact on touch-down bearing performance shall be considered when liquid contamination is either inevitable or is a potential by-product of off-design machine operation.

### 6.5.5 Operating temperature

It is generally assumed that the touch-down bearings will experience the same temperature environment as the rotor and the AMBs. Sliding and rolling contact performance are both generally degraded by temperature extremes (either hot or cold) and compliant elements can be similarly sensitive. It shall be ensured that the touch-down bearings are tested over the expected operating temperature range of the machine.

### 6.5.6 Available cooling flow

The design of the touch-down bearing will in some cases include a requirement for a minimum cooling flow through the touch-down rotor stator clearance and/or through the touch-down bearing assembly. In applications where the available cooling flow is restricted, this can limit the available choices of touch-down bearing. Whichever touch-down bearing design is selected, it shall have a cooling flow requirement compatible with the available cooling flow. This includes the temperature range of the cooling medium, range of pressure and range of flow.

## 6.6 Rotordynamic modelling considerations

### 6.6.1 General

Rotordynamic simulation is used to predict motion and force at the touch-down bearings for machines in critical service thus providing key touch-down bearing design requirements. The simulations shall also provide predictions of relative rotor-stator response sufficient to evaluate potential contact or excess motion at axial locations other than the touch-down bearings. This clause outlines rotordynamic modelling requirements to provide an adequate system model. [Clause 7](#) describes the types of simulation that should be performed to capture expected loading or event scenarios for touch-down bearing operation.

### 6.6.2 Rotor and housing modelling requirements

#### 6.6.2.1 General

Rotor and housing/casing models shall be able to reproduce the lateral as well as the axial dynamics of the system.

### 6.6.2.2 Rotor models

The rotor model shall describe the dynamics of the rotor before, during and after rotor-touch-down bearing contact. Vibration modes significantly higher than the rotor speed can be excited by the impact and so the models shall cover a frequency range, which is greater than the maximum rotor speed (typically 5× to 10× maximum rotor speed). If the rotor has blades or bladed impellers, the importance of their vibration modes to the overall system response shall be considered and if necessary, included in the model.

The rotor model may be nonlinear but usually linear models are used and are typically derived from a beam-element model or from a reduced finite element model. The granularity of the model shall be sufficient to allow the application of the expected forces and to predict the relative rotor/stator clearance at all axial locations of interest. In practice, this means nodes or stations shall be provided at:

- a) bearing locations (touch-down, magnetic, conventional);
- b) position sensors;
- c) seal locations;
- d) impeller locations;
- e) couplings or other added rigid components;
- f) balance planes;
- g) locations to represent added unbalance;
- h) motor/generator locations.

The topics to be taken account of in the rotor model are:

- i) lateral modes/critical speeds;
- j) axial modes (e.g. thrust disk mode);
- k) impellers, blades and couplings;
- l) seals and associated fluid and mechanical contact effects;
- m) motor magnetic forces;
- n) AMB permanent magnet forces;
- o) material damping;
- p) lateral and axial displacements and relative clearances at close clearance locations (e.g. touch-down bearings, sensors, seals).

### 6.6.2.3 Housing/casing models

Modelling the rotor is essential but in many cases housing vibration modes can be excited by rotor-stator contact and contribute to the relative clearances and a dynamic model of the housing/casing shall also be included in the simulation. As with the rotor model, nodes or stations should be provided at all locations where forces will be applied. Displacement information is needed of:

- a) bearing locations (touch-down, magnetic, conventional);
- b) position sensors;
- c) seal locations;
- d) impeller locations;

- e) motor/generator locations;
- f) housing support locations;
- g) non-rotating masses supported by the touch-down bearing compliant element.

The force transmitted between the rotor and housing is realized by the touch-down bearings in combination with existing magnetic and fluid effects. In addition to the touch-down bearing model itself, a model of the compliant mounts between touch-down bearing and touch-down bearing carrier is required (see 7.2, Step 5 and Step 6). This component can be crucial to the behaviour of the whole simulation model.

Requirements for housing/casing models (which may be either linear or nonlinear) are:

- h) relevant lateral and axial housing modes to be included;
- i) compliant housing support characterization;
- j) touch-down bearing compliant mount characterization;
- k) material damping characterization.

### 6.6.3 Touch-down bearing soft mount design considerations

When a rotor drops onto the touch-down bearings, the mechanical bearing will typically provide relatively little damping. This means that the rotor vibration response, as it runs down through various rotor/structural resonances, can be very high so as to produce unintended contact between the rotor and the stator. Consequently, there is a desire to provide a damping mechanism associated with the touch-down bearing and this is most readily and most commonly accomplished by adding compliance to the touch-down bearing by soft mounting it. This additional compliance would result in even larger rotor response excursions during the touch-down event if no further action were taken. Consequently, making the mount softer requires reducing the touch-down bearing clearance in order to ensure that the total displacement (touch-down bearing clearance plus soft mount deflection) is small enough to still protect the machine. A good design achieves an acceptable balance between damping and amount of rotor free motion prior to touch-down bearing contact.

### 6.6.4 Touch-down bearing clearance design considerations

The total rotor/stator relative displacement is a function of the sum of the soft mount deflection and the clearance in the touch-down bearing. Design of the clearance shall take into account expected AMB unbalance response, response when running on touch-down bearings, realistic manufacturing tolerances and thermal effects, and a good design seeks to minimize the total relative displacement. This is normally a subject of discussion between vendor and customer.

### 6.6.5 Friction between the rotor and touch-down bearing design considerations

When a spinning rotor makes contact with a stationary touch-down bearing, the initial slip induces a friction force applied to the rotor that opposes the spin. With rolling element touch-down bearings, the contact quickly spins up the inner ring (or race) of the bearing to closely match the rotor speed, and the remaining friction from radial contact is much smaller than the rolling friction of the touch-down bearing. For a damaged rolling element touch-down bearing or for a poorly designed sleeve touch-down bearing (one not having a properly low coefficient of sliding friction), the resisting torque can cause the rotor to roll around the touch-down bearing clearance in reverse spin direction (backward whirl).

Additionally, friction at the axial touch-down bearing contact face produces a forward tangential force on the rotor when the rotor is off-centre in the touch-down bearing. This force is proportional to the axial contact force and to the friction coefficient between the rotor and touch-down bearing. This force is the usual driver of low-frequency forward whirl during touch-down bearing operation. Such whirl is commonly observed both in vertical machines and in horizontal machines that have high thrust loads.

## 6.7 Contact classification/severity

### 6.7.1 Contact duration

#### 6.7.1.1 Momentary contact

The AMBs quickly re-centre the shaft after a large excursion. Following a momentary contact, the system returns to normal operation and a trip signal could or could not be generated. A momentary contact is typically triggered by a short overload of the AMBs (e.g. following compressor surge).

The AMB vendor sets the maximum time for a large excursion to be judged as a momentary contact based on the application. This can be proprietary information.

Although the contact time is short it shall not be neglected and should be included in the damage counter of [8.4](#).

#### 6.7.1.2 Longer-duration contact

If the contact lasts longer than the threshold for momentary contact time, it is considered as a longer-duration contact. Subsequent behaviour is influenced by control action as described in [6.8.2](#).

### 6.7.2 Types of motion

#### 6.7.2.1 General

The shaft can exhibit different orbit responses such as pendulum (rocking) vibration, combined rub and bouncing and full rub (backward or forward whirling), see [Figure 3](#).

#### 6.7.2.2 Bouncing

The initial transient motion of the rotor, as it contacts the touch-down bearing, is typically bouncing, where the rotor moves in a combination of radial and tangential directions until it contacts the touch-down bearing and the contact impact produces some degree of reversal of the radial component of the motion, so that the contact is nearly immediately broken. This process typically persists for a period. In most cases, bouncing decays and is replaced either by: forward whirl, backward whirl, or rocking. If bouncing persists, the result is an increased number of impacts and higher average load than a typical touch-down bearing event.

#### 6.7.2.3 Rocking

In rocking motion, the rotor exhibits persistent contact with the touch-down bearings, but the motion oscillates around an equilibrium position typically aligned with the mass of the rotor, but sometimes it is also partly controlled by the static loads acting on the rotor. In rocking motion, the oscillation is angular with the angular amplitude less than 180°. This is the most benign persistent rotor contact behaviour and results in the least damage both to the rotor and the touch-down bearings.

#### 6.7.2.4 Forward whirl

Forward whirl is generally induced by mass unbalance in the rotor or friction at an axial contact face (e.g. axial touch-down surface). It can also be induced by fluid dynamic cross-coupling. In fully developed forward whirl, the rotor axis exhibits a circular motion with a direction the same as that of rotor rotation. At the touch-down bearings, the motion is large enough that the rotor stays in contact with the touch-down bearings throughout the whirling motion. The frequency of the motion can be the same as the rotational speed (synchronous forward whirl) or it can be at a lower frequency.

### 6.7.2.5 Backward whirl

Backward whirl is generally induced by rotor-stator friction at the radial contact surface, although it can also be induced by fluid dynamic cross-coupling. In fully developed backward whirl, the rotor axis exhibits a circular motion with a direction opposite to that of rotor rotation. At the touch-down bearings, the motion is large enough that the rotor stays in contact with the touch-down bearings throughout the whirling motion. The frequency of the motion can be significantly higher than the shaft rotational speed or it can be at a lower frequency. Fully developed backward whirl in the clearance of the touch-down bearing involves very large contact forces at the touch-down bearings due to centrifugal forces with a very high potential for rotor and touch-down bearing damage, so it shall be avoided.

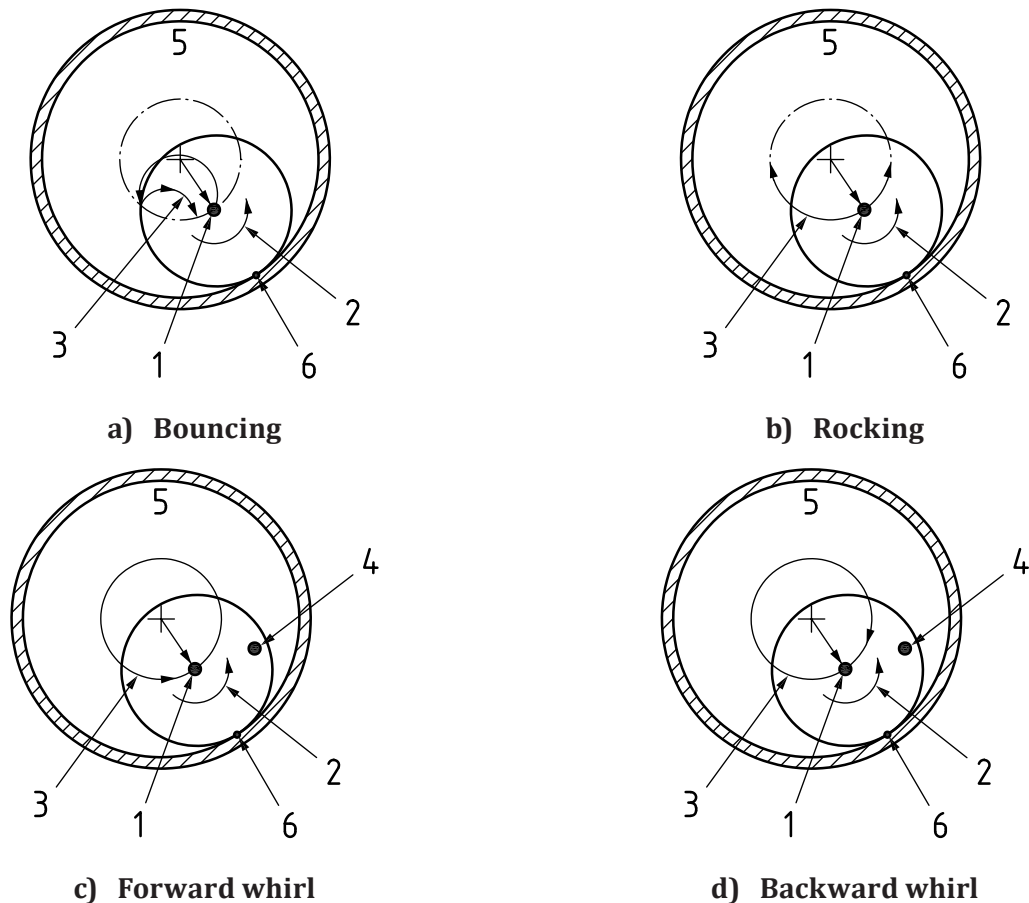

**Key**

- 1 shaft geometric centre
- 2 shaft rotational direction
- 3 motion of the shaft geometric centre
- 4 mass unbalance
- 5 touch-down bearing landing surface
- 6 contact area

**Figure 3 — Rotor orbit motion types when making contacts with a touch-down bearing**

## 6.8 Control actions following touch-down bearing contact

### 6.8.1 General

The actions taken by the MBC following touch-down bearing contact strongly influence the resulting severity, character and duration of the touch-down event. Introducing braking to quickly reduce the rotational speed of the rotor, results in less cumulative damage during a particular touch-down event.

### 6.8.2 AMB controller action

Options for controller action following touch-down bearing contact include:

- a) recovery of controlled levitation within a pre-set time;
- b) unsuccessful recovery within pre-set time, leading to some combination of these actions:
  - i) modification of control and attempt to recover levitation;
  - ii) delevitation followed by relevation after a pre-set time delay or lower speed;
  - iii) attempt to recover levitation and issue a trip request to the system controller;
  - iv) delevitate and issue a trip request;
  - v) delevitation followed by relevation on a redundant AMB controller.
- c) modification or suppression of alarm/trip warnings for known events (e.g. expected impulse).

### 6.8.3 Plant/variable-frequency drive control actions

In specific applications, one or more of these scenarios can apply during spin down and affect rundown speed versus time:

- a) rundown with compressor braking (consider lowest power scenario);
- b) rundown with regeneration/resistive braking and anti-surge valve open;
- c) rundown with compressor braking and regeneration/resistive braking;
- d) rundown with regeneration/resistive braking;
- e) rundown with mechanical braking;
- f) steam/turbine generator scenarios involving torque resistance;
- g) rundown.

Regenerative systems rely on having a connection to a power grid or have brake resistors to bring the rotor to a rapid stop. Single point failure modes that can result in both a hard rotor landing and the connection to a grid being lost shall be considered as part of the design.

## 7 Design and design verification

### 7.1 General

Where there is a temporary or sustained overload to the AMB, an AMB component failure or the AMBs are switched off, touch-down bearings are used to support the rotor. In the case of overload or failure, it is important that the touch-down bearings can withstand the impact of the rotor (e.g. a rotor drop) onto the touch-down bearings, at any operational speed and the subsequent rundown to standstill. It is hence necessary to follow a systematic design process in order to verify the design and durability of the touch-down bearings to ensure the protection of the facility personnel and machinery. The design



verification of the touch-down bearings is achieved using a combination of simulations, calculations, component tests and drop tests. The objective is to show that the touch-down bearing does not fail in relevant modes (e.g. the rolling elements do not break, the raceways do not deform, lose hardness or melt), the air gaps and tolerances are large enough to prevent dangerous contact between machine elements. 7.2 presents a systematic design process.

## 7.2 Design process details

Figure 4 provides an indication of the design process flow logic, which is explained in the following steps.

### Step 1: Functional requirements

The main classes of functional requirement are:

- a) load case requirements:
  - i) selection of important failure cases that lead to a contact events according to a risk analysis (e.g. power loss, component failure, excessive process forces). Consideration of additional forces due to operation of the shaft away from the touch-down bearing centre should be included in the requirements;
  - ii) braking conditions (e.g. active braking, process braking, friction braking);
  - iii) reaction strategy of the magnetic bearing controller;
  - iv) load duration (e.g. full rundown from operational speed to zero speed, intermittent contact, speed versus time curve); and
  - v) number and type of allowable contact events.



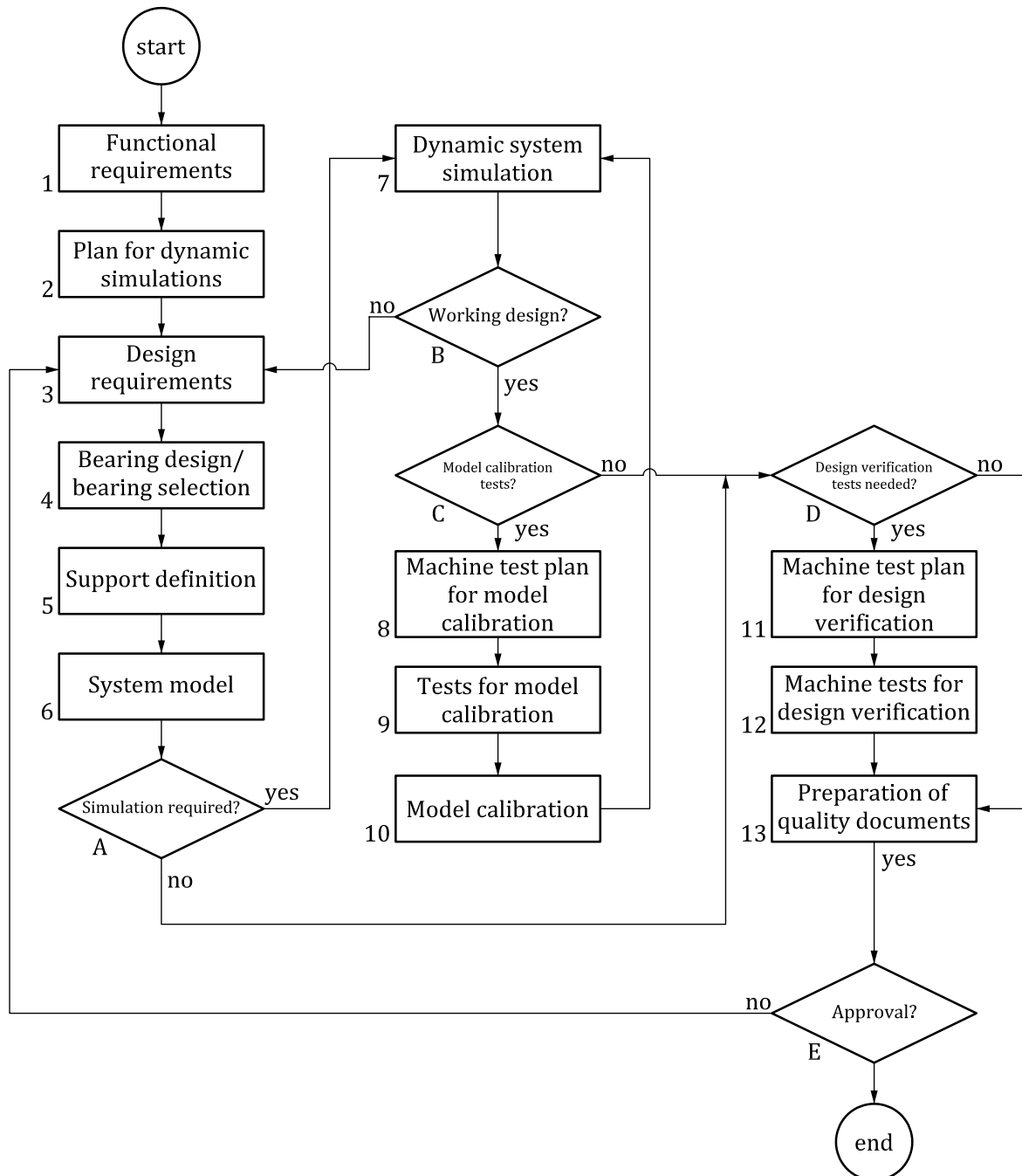

**Key**

- 1 to 13 process steps
- A to E decision points

**Figure 4 — Design process flow diagram**

- b) environmental requirements:
  - i) temperature;
  - ii) heat transfer mechanisms;
  - iii) pressure;
  - iv) humidity;

- v) composition of surrounding medium; and
- vi) dust.
- c) production and maintenance requirements:
  - i) dimensions and tolerances, fixation method used on pedestal/housing;
  - ii) ease of assembly and installation;
  - iii) accessibility for inspection and maintenance;
  - iv) lubrication requirements;
  - v) maintenance intervals;
  - vi) inspection plan;
  - vii) ease of inspection;
  - viii) ease of component replacement;
  - ix) transport requirements.
- d) certification requirements.

Environmental and production/maintenance requirements are mainly fulfilled by selecting proper materials and dimensions for the touch-down bearings. In order to define the nature and duration of the loads that will be imposed on the touch-down bearings during service, it is necessary to clarify which load cases a touch-down bearing shall withstand. Since not all cases can be covered, it is necessary to select the most important ones (e.g. the likelihood of an event and its severity) with the first step being to define and select those for which the touch-down bearings are intended to be used for. Case selection shall take account of response actions taken by the AMB control system, the process control system and, where applicable, the safety system (e.g. valve actuation, active braking, different braking profiles, recovery strategies of the AMB control system).

These cases are useful for use in subsequent development processes and they offer high-level descriptions for customers and engineers on site, which are useful for integration of the machinery in high-level risk analyses and operational safety procedures.

## **Step 2: Dynamic simulation plan**

Dynamic simulations are used to calculate forces, loads, stresses, deflections and temperatures within touch-down bearings and the machine due to the load cases described in Step 1. The level of detail in these simulations shall be adequate to arrive at the desired outcome. For machines in non-critical service, the detailed simulation process may be bypassed if the designer can show that it is unnecessary as discussed in [Figure 4](#), Decision Point A.

The dynamic simulation plan consists of:

- a) The cases to be simulated including those cases that can be used to calibrate the simulation models;
- b) The simulation setup, e.g.:
  - i) full multibody simulation;
  - ii) finite element simulation;
  - iii) simulation software; or

- iv) no simulation performed (only for machines not critical for operations).
- c) The definition of simulation parameters, e.g.:
  - i) rotational speed of the rotor;
  - ii) mass eccentricity distribution of the rotor when supported on touch-down bearings;
  - iii) braking torque versus time;
  - iv) rotor position prior to the touch-down event;
  - v) direction of rotor movement/acceleration prior to the touch-down event;
  - vi) direction, magnitude and dynamics of additional forces;
  - vii) heat transfer mechanisms.
- d) The assignment of numeric values to the parameters defined in Step 2c) and for the cases defined in Step 2a).
- e) Simulation outcome, for example:
  - i) forces;
  - ii) stresses;
  - iii) heat generation estimates (e.g. temperatures of touch-down bearings, rotor and stator parts);
  - iv) tilting and deflection of the rotor;
  - v) statistical certainty of the simulation results;
  - vi) eigenvectors of the rotor system.

### **Step 3: Design requirements**

Some of the design requirements are taken directly from the collection of functional requirements, dimensions and tolerances, while others need to be calculated (e.g. by dynamic simulation). Since dynamic simulations require a defined design (e.g. dimensions, number of balls for rolling element touch-down bearings, materials, assumptions about stiffness and damping values) as simulation input, the determination of the design requirements is generally an iterative process.

The design requirements for touch-down bearings shall take into account:

- a) dimensions of the bearing and its parts;
- b) peak stresses and required stress margins for the raceways and balls;
- c) surface pressure in the contact zone;
- d) peak temperatures and required temperature margins;
- e) fatigue cycles (e.g. S-N curve) and fatigue life assessment;
- f) corrosion resistance;
- g) maximum allowable speed;
- h) force limit depending on the tilting angle;
- i) lubrication and lubrication related (e.g. maintenance) requirements;
- j) damping properties.

#### **Step 4: Bearing design and selection**

Based on the requirements of Step 3 it is possible to select bearings from a catalogue or, if a suitable bearing is not available, a new bearing can be designed. For a new developed design, it is necessary to prove that the required properties are fulfilled by a combination of calculation and measurements.

The data sheet for the bearing unit shall include:

- a) geometric properties as defined in the drawings, confirmed by measurements including protocols (e.g. dimensions, inertia, groove factors, contact angle);
- b) damping and stiffness (as introduced by material or design), e.g. corrugated ribbon;
- c) tolerances (e.g. rotor sleeve eccentricity);
- d) lubrication and lubrication related requirements (e.g. maintenance);
- e) preload;
- f) number of balls;
- g) bearing friction (resisting torque);
- h) ball spin frequency (BSF), ball pass frequency inner ring (BPFI), ball pass frequency outer ring (BPFO);
- i) maximum allowed force/stress on raceways and balls;
- j) maximum allowed impulse;
- k) material properties, including stiffness, yield strength, tensile strength, breaking strength, and temperature behaviour.

#### **Step 5: Bearing/bushing and compliant support requirements**

For a dynamic simulation, it is necessary to define the touch-down bearing support properties. In most cases, a compliant (or resilient) mount is used to reduce the effective stiffness and to introduce damping. Thus, the direction-dependent stiffness and damping properties are essential parameters that need to be considered.

#### **Decision Point A: Is a dynamic simulation required?**

Dynamic simulations are used to calculate forces, loads, stresses and deflections within the touch-down bearings and the machine in accordance with the simulation plan described in Step 2. The level of detail in these simulations shall be adequate to achieve the desired outcome. For machines in non-critical service, the detailed simulation process may be bypassed if the designer can show that it is unnecessary. This choice could be made as a result of prior experience with a similar design and design requirements (e.g. benign loading conditions and fast spin down times). For machines used in critical applications (e.g. where premature failure of the touch-down bearings results in safety concerns, unacceptable down time to the machine or the overall system), a dynamic simulation shall be performed.

If a dynamic simulation is to be performed, the next task is Step 6, as a result of the next step is Decision Point D.

#### **Step 6: System model**

The system model comprises the complete machine setup including the rotor, bearings, support and foundation, and current best practice is to use a transient, nonlinear rotordynamic simulation. The objective is to obtain an adequate representation of the dynamic properties of these components with respect to their motions, forces and stresses so as to be sure that the simulation provides an adequate representation of the system and that the results can be relied upon as described in Step 2. These values provide a basis for deriving design requirements as described in Step 3.

The simulation setup is usually based on using a physical modelling approach (which allows extrapolation) taking into consideration the characteristic properties of the touch-down bearings and the machine setup (e.g. stiffness and damping of the balls, raceways and the compliant support as applicable). The system modelling can be undertaken with different levels of abstraction. These two approaches with respect to their internal model structure are commonly used:

a) Approach 1:

- i) touch-down bearing free clearance (deadband);
- ii) rotor/inner ring contact stiffness;
- iii) compliant mount stiffness, damping and hard stop clearance (see [Clause 4](#), [Figures 1](#) and [2](#));
- iv) detailed ball bearing model that accounts for ball/race stiffness, ball and ring dynamics and temperature;
- v) calculation of Hertzian contact stress, subsurface and surface shear stresses; and
- vi) damage and/or life assessment based on stress amplitude and cycles.

Approach 1 has the advantage of producing a stress and life estimate together with the dynamic analysis.

b) Approach 2:

- i) touch-down bearing free clearance (deadband);
- ii) rotor/inner ring contact stiffness;
- iii) compliant mount stiffness, damping and hard stop clearance (see [Clause 4](#), [Figures 1](#) and [2](#));
- iv) bearing stiffness represented by speed-dependent force versus deflection curves to represent the ball race interaction; and
- v) analysis for temperature effects, stress and life assessment are performed separately after the dynamic analysis.

Approach 2 has the advantage of having a much faster run time and higher stability allowing numerous parametric studies to be performed in a given time.

Beside the internal model structure, the system model defines the interfaces, e.g. the simulation input, the simulation output as well as the model parameters that are used to adjust the simulation. An incomplete list of such interface parameters is:

c) simulation input:

- i) static loads on the rotor;
- ii) dynamic loads on the rotor;
- iii) unbalance loads;
- iv) whirl loads – estimate from natural frequency;
- v) process loads;
- vi) impulse or transient loads and durations; and
- vii) braking curve.

d) simulation output:

- i) dynamic loads on the bearings and its parts;

- ii) transient temperatures in touch-down bearings;
  - iii) analytical load, power dissipation, displacement and temperature predictions using external loads, speed, time, temperature; and
  - iv) motion of the bearing and machine parts.
- e) adjustment parameters:
- i) damping of the bearing and the support;
  - ii) stiffness of the bearing and the support;
  - iii) friction coefficients;
  - iv) rotordynamic description of the rotor; and
  - v) parameters representing tolerances in the setup (e.g. clearances).

Since such a model is complex, it is highly advisable to use either already available commercial or proprietary software. If proprietary software is used, it should be developed in accordance with a structured development process which includes appropriate quality assurance measures.

Independent from the modelling approach used, the system model shall:

- f) be able to simulate the cases as described in Step 1 and Step 2;
- g) offer a method to calibrate the model, in particular where to obtain the values for the model parameters (e.g. data sheets, documented tests, text books, assumptions) and how to apply them;
- h) provide a method that can be used to evaluate the model quality, which is particularly important to estimate the reliability of the calculated results and to evaluate possible residual risk resulting from the uncertainties used.

### **Step 7: Dynamic system simulation**

The system model is used for dynamic simulation in order to obtain an estimate as to whether the touch-down bearing design will function in the applications described in Step 2. The output of the simulation as described in Step 6 together with its estimated uncertainties shall be compiled in a report for a later comparison against the limits given in the bearing data sheet and the limits resulting from the machine design.

Together with the simulation results, it is necessary to document the input data used as well as the simulation parameters and their origin. In particular, the usage of assumed values shall be clearly marked so that an evaluation of the uncertainties can be carried out and a decision can be made regarding whether calibration tests are required to reduce the residual uncertainty in the simulation results.

### **Decision Point B: Working design?**

Before starting the manufacturing phase, it is necessary to evaluate the design based on the results of the calculations and simulations carried out in Step 7. This decision point comprises of a comparison of the simulation results with the limits of the bearings and the other parts of the machine design. Exceeding any of the limits requires a change in the design requirements (e.g. a return to Step 3). If it is not possible to modify the design requirements, even a modification of the functional requirements could be envisaged.

If the simulation results are within the limits of the bearing and machine design, it is then possible to proceed with the manufacturing and assembly of the bearings.

### **Decision Point C: Model calibration tests required?**

Depending on the simulation setup and the uncertainties resulting from unknown parameter values, it can be necessary to obtain further information for use in the system model calibration by performing calibration tests.

This decision depends on having prior experience with similar designs, quality guidelines and a risk analyses. In many cases, it is possible to estimate unknown parameter values by interpolation or extrapolation of the information from previous projects that have implemented the designs.

If tests are necessary to obtain unknown parameter values then the next task to perform is Step 8, otherwise the next step is Decision Point D.

### **Step 8: Machine test plan for model calibration**

The test plan for model calibration comprises of performing tests for determining and inferring unknown parameter values for inclusion in the simulation model and carrying out an estimation of their uncertainties. The test plan shall include tests for training (estimating the model parameters) and validation (confirming that the estimated model is fit for purpose). Repeatability tests can be included in the test plan in order to estimate parameter uncertainties. Tests for model calibration can be performed as necessary in the completely assembled machine or in parts of the machine.

Typical parameters that can be identified by calibration tests are stiffnesses/compliances, damping coefficients, friction coefficients and actual dimensions of parts after manufacturing.

Furthermore, a test plan shall contain the criteria for the evaluation of the model quality, such as:

- a) resonance frequencies;
- b) rundown time-frequency analysis;
- c) rotor deflections as measured at the position sensors, including rotor deflection and rebound height due to the first impact;
- d) pedestal vibration data.

### **Step 9: Tests for model calibration**

Perform the tests described in Step 8.

### **Step 10: Model calibration**

In this step, the unknown parameters are inferred from the training data gained from the calibration tests. The parameter estimates are validated against the validation data of the calibration tests using the quality criteria specified in Step 8. In order to achieve a sufficient level of generalization it is necessary to strictly separate training from validation. The data from the repeatability tests are used to estimate the statistical uncertainty of the inferred parameter values.

The dynamic simulations described in Step 7 are repeated with the now calibrated model.

### **Decision Point D: Are design verification tests needed?**

Depending on prior experience from existing designs or customer requirements it can be necessary to validate the simulation results by performing tests in a real machine setup. Parameters that could be taken into account when deciding whether to perform tests on a real machine can include:

- a) rotordynamics;
- b) rotor speed and dimensions of the touch-down bearings;
- c) touch-down bearing design;
- d) external loads;
- e) control actions taken in response to a failure in the AMB system.

These and other criteria can be used in a risk analysis that informs the decision regarding whether additional tests using a real machine setup shall be performed.

### **Step 11: Machine test plan for design verification**

Tests in the machine setup are used to excite the whole system and to measure the related responses. Often, the excitation is performed by dropping the rotor into the touch-down bearings at different speeds – (drop tests).

In principle, there are various ways to accomplish a drop, e.g. by:

- a) switching off one or more of the AMB control axes;
- b) applying an additional force vector which pushes the rotor into the touch-down bearings applying a large off-centre set point for the closed-loop control;
- c) activating an unstable closed-loop controller (possibly difficult to choose).

The objective of the drop test is fivefold. A drop test can be used to:

- d) calibrate the simulation model, which is particularly useful as it excites the whole system with sufficient energy during touch-down;
- e) confirm the correctness of the simulations (in particular for the scenarios described in Step 1 and Step 2) by determining the estimation errors and the statistical uncertainty of the predicted results, including forces, stresses and deflections;
- f) provide verification data for effects that are difficult to simulate with respect to the proper functioning of the design such as when other damage occurs (e.g. cracks, the generation of metal particles, overheating, permanent deformation, wear and component loosening);
- g) provide the final verification of the proper functioning of the test set up (e.g. during a customer acceptance test);
- h) help to identify damage progression and to support the development of vibration condition monitoring acceptance criteria.

Once the drop test has been performed, additional inspection and analysis of the touch-down bearings can be carried out, e.g.:

- i) optical inspection;
- j) crack inspection;
- k) rolling element bearing condition monitoring (vibration and sound analysis);
- l) temperature measurement;
- m) endoscopic analyses;
- n) chemical abrasion analysis.

The successful outcome for the drop test depends on carrying out thorough test preparation. As a first step, a test plan shall be written including tests that have been simulated before and those described in Step 1. As part of completing the actions for Decision Point B, it is shown that the forces, stresses and deflections do not exceed the limits of the touch-down bearings and the machine. Furthermore, it is possible later on to validate the simulation results against the measurements taken from a drop test and hence to increase confidence in the simulation results that are not verified by carrying out a drop test.

An essential part of the test plan is to clarify how the drop test cases can be implemented in a test environment (e.g. how the simulation parameters can be brought in line with the capabilities of the test



facility). Careful planning shall ensure that the measured signals are in alignment with their simulated counterparts (e.g. direction of the measured vibrations, deflections).

Part of the test preparatory work is to define the quality of the measurement chain (e.g. with respect to noise, disturbance, sampling rate, synchronization and bit resolution).

Since potential damage to the touch-down bearing could be heavy, it is essential to carry out a risk analysis and to have a working safety concept in place in advance of performing drop tests. The drop test go/no-go criteria shall be evaluated after each drop test.

Prior to starting the tests, it is necessary to define a documentation concept so as to be able to handle (e.g. storage, data formats, analysis software) the huge amount of data which will be recorded. As part of the safety concept, it is required to define analysis procedures that shall be performed between the drop tests. In particular, investigations that cannot be covered by simulations shall be planned.

### **Step 12: Machine tests for design verification**

The drop test starts with the determination and documentation of the initial state of the touch-down bearings (e.g. by performing an initial fingerprint ball bearing condition monitoring run).

The execution of the drop test shall follow the test plan described in Step 8. After each drop is performed, it is necessary to establish the state of the touch-down bearings. In particular:

- a) ball bearing condition and monitoring status;
- b) to evaluate the dynamic measurements taken to check for any increase of the BSF or the occurrences of the BPF1 and BPF0;
- c) to establish the quality of the measurements taken (e.g. suitable frequency resolution, length of measurement, bit resolution);
- d) optical inspection (e.g. using an endoscope camera);
- e) crack inspection;
- f) chemical analysis of any abrasions (e.g. by metallurgical analysis).

Furthermore, after each drop it is necessary to compare the results of the prior simulation against the measured signals in order to continuously evaluate the quality of the simulation model based on the quality criteria from Step 8. Where differences are apparent, it can be necessary to re-calibrate the model and to re-run the drop test simulations in order to more accurately predict the expected forces and stresses, and to evaluate the potential risk of failure during the remaining drop tests.

In cases where the simulation is bypassed, but the verification tests were performed, the measured signals shall be reviewed for

- g) character of the trajectory during drop and spin down, for instance, looking for the existence of
  - i) forward or backward whirl and associated whirl frequencies,
  - ii) rotor rocking, and
  - iii) rotor bouncing in the clearance space;
- h) peak relative rotor/housing displacement compared to critical machine clearances, and
- i) temperature rise versus drop time (when measured).

### **Step 13: Preparation of quality documents**

In order to arrive at a final decision for the AMB design approval, the simulation results and the test results shall be compiled into a document which shall be used to provide the basis for making the decision.

## Decision Point E: Approval?

Based on the documentation compiled in Step 13 a decision regarding the design approval can be made.

### 7.3 Documentation

In order to achieve traceability of the verification process and the test and simulation results, it is necessary to have a documentation concept in place, which describes the

- a) model setup and parameter values used,
- b) measurements taken, certificates and sources of information used,
- c) the drop test setup and, in particular, the measurement equipment used and their positions,
- d) model quality/statistical certainty (e.g. simulation versus measurement, root-mean-square error);
- e) simulation results – in relation to the parameter limits set, and
- f) the verdict.

## 8 Condition monitoring and damage estimation methods

### 8.1 General

This clause describes methods that can be used for the condition monitoring of touch-down bearings and how to estimate their in-service status and the triggering of corrective actions when necessary. Damage to the touch-down bearings can be estimated either by using operational event triggered measurement data or from performing an inspection. The collected data are analysed either online in real-time by the MBC or offline using more advanced, higher order, algorithms.

### 8.2 Event detection and data capture

#### 8.2.1 Contact detection

A contact is detected by a radial or axial displacement of the shaft exceeding a predefined threshold. Such a predefined threshold shall be less than the touch-down bearing clearance.

Other signals could also be used to detect touch-down such as those generated by inner race speed probes, force transducers or accelerometers.

Regardless of the method used, the control system shall continuously monitor for contact events.

#### 8.2.2 Contact event

A typical method to determine, if a detected contact, is judged a contact event is to require that the rotor speed exceeds a specified threshold and the contact has duration longer than a specified minimum time. The minimum speed threshold and the minimum time depend on the application.

Alternative methods such as filtering of the contact signal can be deployed to achieve the same purpose.

Contacts that do not meet the event criteria are disregarded.

Examples of trigger events that can cause contact events are given in [6.2](#). The control system shall record contact events and counter increments together with other data (e.g. rotor speed, displacements, currents) for analysis.

Following touch-down, the shaft can exhibit different contact signal signatures which indicate different load cases of the touch-down bearings (see [6.7](#)). The condition monitoring system shall consider this

and distinguish different load cases with regards to contact time and signal signature and quantify them.

## **8.3 Inspection**

### **8.3.1 General**

Inspection can be required in order to verify the condition of the touch-down bearings following a contact or on a periodic basis (as defined in the inspection plan). These inspections can be categorized into two classes:

- a) non-intrusive, where disassembly of the machine is not required to access the touch-down bearings and it can be brought back into service as quickly as possible;
- b) intrusive where, as a minimum, partial disassembly of the machine is required in order to access the touch-down bearings in order to bring it back into service.

Any inspection shall start with the non-intrusive inspection. In the event that the non-intrusive inspection indicates a problem, an intrusive inspection shall be performed.

### **8.3.2 Common techniques in non-intrusive inspection**

#### **8.3.2.1 Clearance check**

A modified clearance between the rotor and touch-down bearing can be an indication of degradation of the touch-down bearing. The levitated rotor is shifted off the centre towards the inner race and the contact is detected by a steep increase in coil current. The sensed displacement at the contact point is the clearance. It is assumed that a certain deviation of the clearance from an initial value (increase or decrease) indicates a degradation of the touch-down bearing. The choice of the threshold for failure depends on the system and shall be specified by the vendor.

#### **8.3.2.2 Touch-down bearing low-speed rundown test**

A defect in a touch-down bearing can increase the braking torque, which it transfers to the rotor. By estimating the actual braking torque and comparing it to a reference value, possible defects of the touch-down bearings can be identified. The braking torque from the touch-down bearings is estimated by measuring speed curves over time (rundown curves) after the rotor has been dropped into the touch-down bearings at a low rotation speed.

In addition to the touch-down bearings, process gas also causes a braking torque on the rotor. In order to minimize its influence, each time a calibration rundown measurement is performed in which the rotor is not dropped, but only the drive is stopped, the values from the calibration curve are subtracted from those in the measurement data of the dropped rotor and the differences are evaluated.

[Figure 5](#) shows a schematic representation of the values obtained using this procedure.

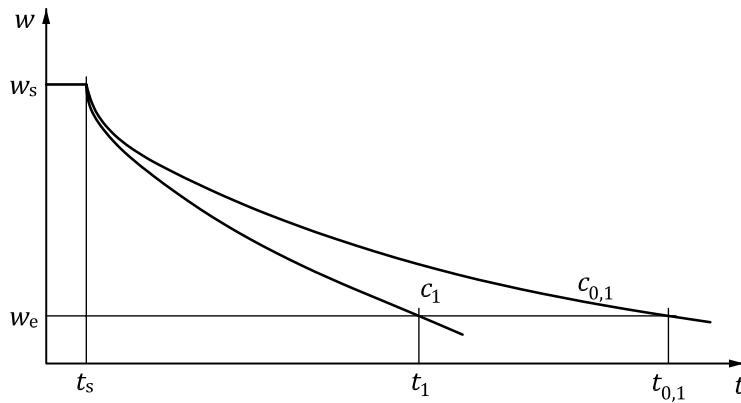

**Key**

- $t$  time [s]
- $w$  rotation speed [ $s^{-1}$ ]
- $w_s$  initial rotation speed
- $t_s$  drop time
- $c_{0,1}$  initial speed curve levitated
- $c_1$  speed curve delevitated
- $w_e$  minimum speed
- $t_1$  rundown duration with rotor delevitated
- $t_{0,1}$  rundown duration with rotor levitated

**Figure 5 — Schematic representation of low-speed rundown measurements**

NOTE A new touch-down bearing can initially exhibit a reduction in braking torque (improved performance) after the first one or two drops and rundown before starting to degrade after subsequent drops.

**8.3.2.3 Borescopic inspection**

A borescope can be used to detect particulate and/or liquid contamination and heavy damage of the touch-down bearings without the need for disassembling the machine. It depends on the design of bearings and machine whether this technique can be used.

**8.3.2.4 Ball pass frequency measurement**

Additional transducers allow for the measurement of ball pass frequencies:

- a) BPFi;
- b) BPFO; and
- c) BSF.

At a constant low speed (e.g. 600  $min^{-1}$ ), perform a frequency analysis of the BPFi, BPFO and BSF and compare the results with the stored values.

**8.3.3 Intrusive inspection**

When an intrusive inspection is indicated by 8.3.1 or a scheduled offline inspection cycle, a detailed inspection of the touch-down bearings can be required. Such an inspection will require, at minimum,

partial machine disassembly to gain access to the touch-down bearings. The aim of such an inspection is to

- a) evaluate the cumulative damage and estimate residual life of the bearings in terms of number of survivable worst-case rundowns,
- b) provide data for future optimization of the touch-down bearing design, and
- c) provide data for improving the online or offline damage estimation algorithm (condition monitoring system).

[8.3.3](#) d) describes a sequence of tasks that could be undertaken during the inspection but not all of the steps will be necessary in every situation. Determination of the level of detail should be agreed between vendor and customer with consideration given to the level of risk and cost to be taken.

- d) Document and photograph touch-down bearings as received for inspection to
  - i) optically inspect and photograph the assembled bearing, noting any accumulation of dirt or contaminants, corrosion, wear, and other defects,
  - ii) collect samples of the remaining lubricant (if any) and/or contaminants for laboratory analysis, and
  - iii) make a qualitative assessment of the rolling surfaces by manually turning the bearing. This can identify heavy brinelling or other damage; however, this may not be definitive due to the possible presence of dirt and debris in the bearing.
  - iv) make a quantitative measurement of breakaway torque, and
  - v) measure the bearing radial play (internal clearance).
- e) Disassemble the bearing and document the condition of its components:
  - i) Optically inspect and photograph the inner and outer raceways, landing surfaces, ball surfaces and other features of interest. Inspection and photographs shall be made with several levels of magnification. Note any accumulation of dirt or contaminants, corrosion, lubricant condition, wear, denting, ball scratches, and other material defects. Note any evidence of wear such as denting, brinelling, ball scratches, spalling, galling, bluing or other visible signs of wear.
  - ii) Clean the bearing with a solvent compatible with the materials of the various components. Note that depending on the application, the bearing may be cleaned before disassembly or not cleaned at all during the inspection.
- f) Measure these bearing component dimensions for comparison with those of a new bearing:
  - i) inner ring:
    - 1) raceway diameter;
    - 2) raceway radius of curvature;
    - 3) raceway profile;
    - 4) bore inner diameter; and
    - 5) axial width.
  - ii) outer ring:
    - 1) raceway diameter;
    - 2) raceway radius of curvature; and

- 3) raceway profile.
- iii) measurements on balls (e.g. 10 % selected at random):
  - 1) surface roughness and depth of roughness of the surface; and
  - 2) diameter.
- iv) measurements on rotor landing surfaces:
  - 1) roughness and diameter of radial landing surfaces; and
  - 2) roughness of axial landing surfaces and distance between them.
- g) For dry bush type touch-down bearings, additional/alternative inspections can include:
  - i) verification of the pre-load setting;
  - ii) inspection of the bonding between the backing material and the dry lubricated material;
  - iii) inspection of the dry lubricated landing surface for damage; and
  - iv) inspection of the dry lubricated landing surface for wear and comparison with wear limits.

These descriptions assume a touch-down bearing mounted to the casing, as shown in [Figure 1](#) and [Figure 2](#). In some machines, this arrangement may be inverted, with the touch-down bearing mounted to the shaft. In such cases, the references to the inner and outer rings are reversed.

## 8.4 Damage estimation

### 8.4.1 Event data

#### 8.4.1.1 General

Estimation of damage for an individual event can be made using either:

- a) touch-down event data analysed online in real-time, or
- b) touch-down event data analysed offline, possibly using more advanced algorithms.

#### 8.4.1.2 Damage estimation through event counters

Each touch-down event will cause some degree of additional damage to a touch-down bearing. A weighted event counter used as an indicator of the actual cumulative damage shall evaluate this damage.

Specific details of damage estimation algorithms can be addressed using these inputs:

- a) contact classification and duration;
- b) a global counter or specific bearing counters;
- c) the recommended weightings associated with each contact event based on experience, user expectation, experimental data and simulation results.

The weights of the individual event shall be adjustable. In case new insights on the touch-down bearing performance is gained over time, the bearing damage can be re-evaluated based on the actual counters.

Examples/parameters that can be used are:

- d) total number of drops;

- e) total number of speed-weighted revolutions of the bearings;
- f) number of momentary contacts (speed weighted);
- g) number of rundowns;
- h) damage from forward or backward whirl assessment; and
- i) normalization by using a single accumulated damage index.

NOTE Damage estimation does not give a direct measure of remaining bearing life. The weighting factors can be adjusted based on vendor and field experience.

It is not possible for the damage estimation algorithm to predict the effect of all types of landing events. Hence there is always a degree of uncertainty and algorithms are selected to be conservative.

### 8.4.1.3 Detection of critical failure

Ordinarily, failure of a touch-down bearing during operation is a cumulative event and is detected as discussed in 8.2. However, catastrophic failure is also a possibility and would be detected as a sudden high level of noise, temperature, vibration, or a combination of these during a touch-down bearing contact. In such an event, the machine shall be stopped as quickly as is practicable and the suspect touch-down bearing shall be inspected as described in 8.3.

## 8.4.2 Inspection-based estimation

### 8.4.2.1 Damage estimation through non-intrusive inspection

Failure of a touch-down bearing would be detected either by a start-up diagnostic examination of the radial clearance of the touch-down bearing (see [Clause 8](#)) or by evidence gathered during operation.

### 8.4.2.2 Damage estimation through full inspection

If an intrusive inspection is made, the results can be used to estimate remaining life or to drive a decision to replace the bearings. Qualitative observations or quantitative measurements from the inspection shall be weighed against similar historical observations from a drop testing campaign. Such a drop testing campaign shall include at least two post drop intrusive inspections to facilitate life estimation. The number of drop tests to perform between inspection cycles shall be based on the expected total.

Quantitative measures obtained from the intrusive inspection that can be compared to new dimensions include:

- a) calculated or directly measured bearing internal clearances;
- b) free radial clearance between bearing bore and landing surface;
- c) free axial clearance between bearing axial contact faces and landing surface;
- d) bearing race curvature;
- e) roughness of rotor landing surfaces and mating bearing surfaces; and
- f) bearing breakaway torque.

Qualitative observations from optical inspection and/or photographs include:

- g) the accumulation of dirt or contaminants, corrosion and poor lubricant condition;
- h) evidence of wear (e.g. debris denting, brinelling, ball scratches, spalling, galling, bluing or other visible signs of wear).

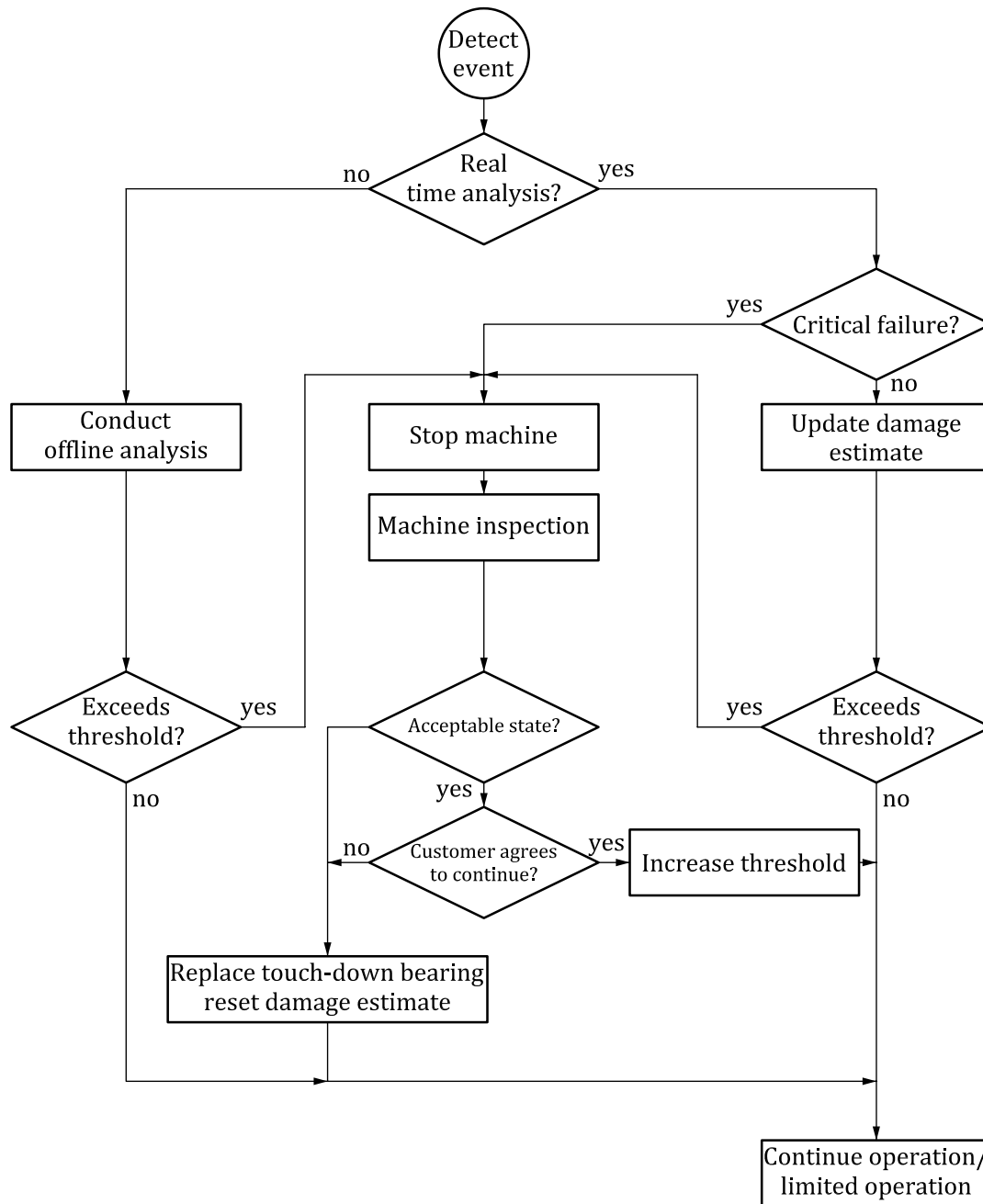

Figure 6 — Flow diagram to assess whether to continue with machine operation after a contact event has been detected

### 8.4.3 Criteria for further operation

Based on 8.4.1.1 a) or/and 8.4.1.1 b) an estimate of cumulative damage for each touch-down bearing can be derived and it shall be decided whether the machine can continue to be operated. Figure 6 shows the decision making process that shall be followed.

In order to continue with machine operation using the installed touch-down bearings, they shall have a predicted life of at least one worst case full-speed landing event remaining. Because of the uncertainty in the damage estimate (see 8.4.1.2), it is advisable to perform an inspection after a landing event and to evaluate the state of the touch-down bearing as described in 8.4.2.

If the inspection results are unsatisfactory, the touch-down bearings shall be refurbished or replaced. If the results are satisfactory, continued operation shall be permitted. If the inspection results are



satisfactory but the predictive life of the touch-down bearing has been exceeded, the vendor and customer may agree to continued operation of the machine either with an increased inspection frequency or for an agreed period until the touch-down bearing is refurbished or replaced. As part of such an agreement, the damage threshold shall be increased to an agreed level.

## **9 Maintenance and life cycle factors**

### **9.1 General**

Magnetic bearing systems require minimal maintenance (as described in ISO 14839-4), however, touch-down bearings can require maintenance, particularly when the accumulated damage approaches the permitted maximum level or operation outside design conditions occurs.

In order to facilitate such maintenance actions, touch-down bearings will typically be held as spare parts and removed units disposed of in an appropriate manner. In this section, in addition to reviewing the typical maintenance actions, the life cycle factors associated with the touch-down bearings to support operation of an AMB equipped machine for the agreed service life are considered.

The vendor shall provide documentation detailing inspection requirements, maintenance requirements, spare part management and decommissioning/disposal.

### **9.2 Inspection plan**

#### **9.2.1 General**

This clause provides a guideline regarding when and how non-intrusive and intrusive inspections should be executed. It is generally required to establish a regular (e.g. cyclic) inspection plan for maintenance as well as a plan for routine checks after the occurrence of a contact event.

#### **9.2.2 Minimum intervention cycle**

Customer and vendor shall agree on the minimum expected life of the touch-down bearings. As specified in [8.3.2](#), the touch-down bearings shall be inspected according to an inspection plan on a cycle that is shorter than the minimum expected life. Inspections are performed in order to verify the full, or in some cases limited, functionality of the touch-down bearings for further operation. If the touch-down bearings are found to have excessive wear as indicated by spalling, galling, bluing, other visible signs of wear by excessive clearance between the rotor and the touch-down surface, or in the case of rolling element bearings by play between the inner and outer races that cannot be corrected by changing the preload, then they shall be replaced. If the touch-down bearings are subject to contamination by particulates, then the inspection cycle shall factor this in.

### **9.3 Interventions**

#### **9.3.1 Routine checks**

##### **9.3.1.1 General**

Routine checks are scheduled either on a regular/cyclic basis or are triggered by an event (e.g. after a drop).

The scope of the routine checks depends on the application and, in particular on the risk connected to a failure of the touch-down bearings, as well as on the type of the touch-down bearings (e.g. roller bearings or sliding bearings).

[9.3.1.2](#) describes measures that shall be executed in case of a touch-down event occurring or as a result of a maintenance related check. They comprise of intrusive and non-intrusive checks but without disassembly of the touch-down bearings.

### 9.3.1.2 Event-triggered routine checks

Routine touch-down bearing checks include:

- a) ball bearing condition monitoring to check for smooth running of the bearings and for damage in the raceways;
- b) clearance check;
- c) borescopic inspection for visible damage (e.g. abrasion); and
- d) analysis of the event buffer data.

An event buffer is a data memory configured to receive and record signals. The signals from transducers shall be relevant to the operation of the AMBs, the touch-down bearings, and/or the AMB equipped machine immediately before and after an event. A typical recording time span can be 60 s before and 60 s after an event, selected by post processing of continuously recorded data.

Relevant signals can include, for example, voltage drops across and currents through the AMB coils, rotor vibration levels, rotor deflections, temperatures and one or more states of the AMB control system. The selection of signals to be recorded depends on their usefulness in an analysis of the state of the AMBs, the touch-down bearings, and/or the AMB equipped machine after the event. The signals can also be selected according to their relevance for the analysis of the event itself, for example, to investigate its origin and time duration.

As an example, rotor deflection signals can be used to analyse time duration(s) and/or intensity of one or more contacts between the rotor and touch-down bearings. For a proper analysis it is important to ensure the quality of the recorded signals (e.g. with respect to bit resolution sampling rate).

### 9.3.1.3 Maintenance related routine checks

Routine checks include:

- a) measurement of the breakaway torque (can be difficult to interpret in case of ball bearings without cage);
- b) ball bearing condition monitoring run to check for smooth running of the bearings and for damage in the raceways;
- c) borescopic inspection for visible damage (e.g. abrasion);
- d) chemical analysis of the abraded material;
- e) clearance check;
- f) actions to be performed in accordance with the maintenance schedule of the touch-down bearing vendor (e.g. relubrication/replacement of bearing balls after expiry of grease lifetime); and
- g) analysis of the event buffer data, reset of counters.

Customer and vendor shall agree which checks shall be performed.

### 9.3.2 Predicted excessive damage accumulation

In the event that predicted damage from accumulation of touch-down events exceeds a threshold agreed to by the customer and vendor, either:

- a) the associated touch-down bearing or bearings shall be refurbished or replaced; or
- b) after inspection, continued operation with a restricted operating profile shall be agreed between the vendor and customer following a suitable engineering assessment; or

- c) after inspection and carrying out a suitable engineering assessment, continued operation with an unrestricted operating profile. In this case, revised damage estimates shall be agreed between the vendor and customer.

### 9.3.3 Contamination

Contamination of either the rolling element or bushing type touch-down bearings by abrasive substances will always lead to damage of the touch-down bearings and shall be avoided. Corrosive substances can also damage the touch-down bearings if they are not rated specifically for use in corrosive service. Upon any indication that the touch-down bearings have been contaminated by an abrasive or corrosive substance and if they not rated for corrosive service, the touch-down bearing shall be cleaned to remove the contamination and checked for damage before return to service.

## 9.4 Maintenance actions

### 9.4.1 General

All maintenance actions associated with the touch-down bearings shall be in accordance with procedures agreed between the touch-down bearing vendor and the customer. The scope of maintenance actions which can be performed by the customer and those that are reserved for the touch-down bearing vendor shall be agreed upon by the customer and vendor.

Whether refurbishment or replacement of touch-down bearings is pursued will depend on their particular design and monetary value and this choice shall be agreed between the vendor and customer at the time of purchase.

Where special tooling is required to perform a maintenance action, the supply of such tooling shall be agreed between the customer and vendor. Such tooling shall be stored safely over the operating life of the machine.

The vendor shall provide to the customer a recommended spare parts list for the touch-down bearings.

References to touch-down bearing rotor parts are only applicable where a touch-down bearing landing sleeve is fitted or where a surface treatment is applied to a section of the rotor to form the landing surface.

### 9.4.2 Touch-down-bearing refurbishment

Touch-down bearing refurbishment can be a more cost-effective course of action than replacement to maintain the operational status of a machine. It can be combined with touch-down bearing replacement whereby the original touch-down bearings are replaced and then the removed touch-down bearing is refurbished to provide a spare.

Following refurbishment of both the rotor sleeve and stator parts of a touch-down bearing, the contact counters shall be reset.

Following refurbishment of only one out of the stator and rotor parts of the touch-down bearing, the action to be taken regarding contact counters shall be agreed between the customer and vendor.

Typical refurbishment actions can include:

- a) Bearing damping element renewal - This can be applied to both rolling element and dry bush-based touch-down bearings. Depending on the complexity of the damping element, this maintenance action may be performed by the customer.
- b) Rolling element bearing renewal - For rolling element-based touch-down bearings, the existing touch-down bearing housing can be retained and new rolling elements (balls and races) fitted into it. In this case, it is important to ensure that any pre-load on the rolling elements is correctly set.

- c) Clean and re-lubricate the bearing - For rolling element-based touch-down bearings, the bearings may be cleaned, dried and then re-lubricated. This process will ordinarily be done by the vendor.
- d) Cleaning - For bush type touch-down bearings, either the rotor or stator parts may be cleaned in order to remove material deposits.
- e) Pad renewal - For bush and washer (thrust) type touch-down bearings using separate pads (either articulated or fixed), the individual pads may be replaced with new pads while retaining the existing touch-down bearing housing. For fixed pads, the customer will typically perform this maintenance action. For articulated pads, because of the complex setup, the maintenance action is usually carried out by the vendor.
- f) Surface treatment of the landing surface - Where the running surface for the touch-down bearing is surface-treated (either directly onto the core shaft or as a removable sleeve), it can be desirable to renew/refurbish the surface treatment of the running surface to repair any damage. In the event of renewal/refurbishment, particular care shall be taken to ensure the touch-down bearing clearance is not affected.

### 9.4.3 Touch-down bearing replacement

Replacement of touch-down bearing assemblies may be of either

- a) touch-down bearing stator assembly, or
- b) rotor sleeve, or
- c) both rotor and stator parts.

It should be noted that removal of shrunk on touch-down rotor parts will typically involve

- d) the use of specialist hydraulic fittings and equipment, or
- e) localized heating, or
- f) slitting the old sleeve.

Following replacement of touch-down bearing assemblies the installation of the touch-down bearing shall be verified in accordance with normal commissioning procedures. Typical checks can include and verify:

- g) touch-down bearing radial clearance;
- h) touch-down bearing radial centring relative to AMB sensors;
- i) touch-down bearing axial clearance;
- j) touch-down bearing axial centring relative to the AMB sensors;
- k) breakaway torque (stiction) for touch-down bearings with pre-loaded angular contact rolling element bearings;
- l) rotor balance following replacement of landing sleeve.

Following replacement of both the rotor sleeve and stator parts of the touch-down bearing, the contact counters shall be reset.

Following replacement of either the stator and rotor parts of the touch-down bearing, the action to be taken regarding contact counters shall be agreed between the customer and vendor.

## 9.5 Life-cycle factors

### 9.5.1 General

This clause addresses the activities associated with spare part management, decommissioning, disposal and obsolescence management of magnetic bearing systems and are considered for the complete life-cycle of the machine.

During the complete life-cycle of a machine equipped with AMBs, the rotor, AMB and touch-down bearing components can become contaminated through contact with hazardous gases (e.g. sour gases containing H<sub>2</sub>S, NO<sub>x</sub> and SO<sub>x</sub>), process fluids (e.g. organic fluids, biological fluids, acids and refrigerants), radioactive isotopes (e.g. deuterium and tritium), heavy metals (e.g. mercury) and through bombardment (e.g. neutrons). These contaminants can adhere to a surface or be evident at subsurface levels. Hence, it should be a requirement to take the appropriate steps to make sure that the wider environment is not contaminated and that the well-being of humans and animals is not compromised when these components are handled for maintenance, repair or disposed of at the end of their service lives.

Precautions to be taken during maintenance, decommissioning and disposal can include (where appropriate):

- a) eliminating contamination of the wider environment through the use of ventilated and pressure-controlled enclosures; and
- b) minimizing the harm to technicians through the end use of appropriate personal protective equipment.

### 9.5.2 Spare part management

It is appropriate to maintain a stock of critical spare parts to minimize machine downtime.

The vendor shall provide to the customer a list of recommended spare parts to stock, which can include:

- a) landing sleeves;
- b) compliant elements;
- c) touch-down bearing sets;
- d) shims necessary for setting the required axial travel or alignment;
- e) specified greases or lubricants;
- f) touch-down bearing pads.

Replacement of parts shall take account of

- g) that in some cases, it can be necessary to transport all or part of the machine to an off-site facility to replace parts;
- h) where parts come in matched pairs, they shall be replaced as matched pairs.

The vendor shall specify those parts that can be refurbished and a process for their refurbishment.

The vendor shall provide indicative lead times for parts not maintained on-hand.

The vendor shall provide storage instructions for the spare parts.

If the part replacement is to be done by the OEM or customer, then the vendor shall provide a procedure for its removal and safe disposal of the old component and for the installation and testing of the new component.

### 9.5.3 Decommissioning, recycling and disposal

End of life, in the context of system or component life cycles, is the final stage of a product's existence and is due to the accumulation of damage, exceeding a threshold agreed between the customer and vendor. At this stage, several processes have to be considered:

- a) The decommissioning process to be used to safely remove a touch-down bearing and associated components from active service and their safe preparation for storage or disposal.
- b) The disassembly process, by which a decommissioned touch-down bearing is reduced to a group of components or subassemblies for safe disposal or reuse. Identification of dangerous parts and contaminated components shall be catalogued. This enables marking the different parts (e.g. type of material or treatment) in order to facilitate their proper disposal.
- c) The disposal process, during which the dismantled touch-down bearing is moved to a location for storage that is environmentally acceptable. Identification of facilities shall be undertaken to assess its availability for recycling, reconditioning or reuse.

### 9.5.4 Obsolescence management

Obsolescence management shall be undertaken so as to be able to prepare plans to identify and mitigate risk when parts, spare parts, manufacturing equipment, personnel skills, and software become obsolete.

ISO 9001 provides systematic processes for use by an organization, including:

- a) The need to demonstrate its ability to consistently provide products and services that meet customer and applicable statutory and regulatory requirements.
- b) Aims to enhance customer satisfaction through the effective application of the system, including processes for improvement of the system and the assurance of conformity to customer and applicable statutory and regulatory requirements.

Vendor and customer shall agree to an obsolescence management programme and the scenarios to be managed for touch-down bearings shall include:

- c) bought-in rolling element bearings no longer available for purchase;
- d) regulatory controls that prohibit the sale or manufacture of existing parts (e.g. coatings, lubricants);
- e) turnover of service personnel; and
- f) the non-availability of specialist manufacturing equipment.

## Bibliography

- [1] ISO 2244, *Packaging — Complete, filled transport packages and unit loads — Horizontal impact tests*
- [2] ISO 9001, *Quality management systems — Requirements*
- [3] ISO 13355, *Packaging — Complete, filled transport packages and unit loads — Vertical random vibration test*
- [4] ISO 14839-2, *Mechanical vibration — Vibration of rotating machinery equipped with active magnetic bearings — Part 2: Evaluation of vibration*
- [5] ISO 14839-3, *Mechanical vibration — Vibration of rotating machinery equipped with active magnetic bearings — Part 3: Evaluation of stability margin*
- [6] ISO 14839-4, *Mechanical vibration — Vibration of rotating machinery equipped with active magnetic bearings — Part 4: Technical guidelines*
- [7] ISO 21940 (all parts), *Mechanical vibration — Rotor balancing*
- [8] ASTM D6344-04, *Standard Test Method for Concentrated Impacts to Transport Packages*







## Bureau of Indian Standards

BIS is a statutory institution established under the *Bureau of Indian Standards Act, 2016* to promote harmonious development of the activities of standardization, marking and quality certification of goods and attending to connected matters in the country.

### Copyright

BIS has the copyright of all its publications. No part of these publications may be reproduced in any form without the prior permission in writing of BIS. This does not preclude the free use, in the course of implementing the standard, of necessary details, such as symbols and sizes, type or grade designations. Enquiries relating to copyright be addressed to the Head (Publication & Sales), BIS.

### Review of Indian Standards

Amendments are issued to standards as the need arises on the basis of comments. Standards are also reviewed periodically; a standard along with amendments is reaffirmed when such review indicates that no changes are needed; if the review indicates that changes are needed, it is taken up for revision. Users of Indian Standards should ascertain that they are in possession of the latest amendments or edition by referring to the website-[www.bis.gov.in](http://www.bis.gov.in) or [www.standardsbis.in](http://www.standardsbis.in).

This Indian Standard has been developed from Doc No.: PGD 13 (24945).

### Amendments Issued Since Publication

Amend No.	Date of Issue	Text Affected

## BUREAU OF INDIAN STANDARDS

### Headquarters:

Manak Bhavan, 9 Bahadur Shah Zafar Marg, New Delhi 110002

Telephones: 2323 0131, 2323 3375, 2323 9402

Website: [www.bis.gov.in](http://www.bis.gov.in)

### Regional Offices:

Central : 601/A, Konnectus Tower -1, 6<sup>th</sup> Floor,  
DMRC Building, Bhavbhuti Marg, New  
Delhi 110002

Telephones

{ 2323 7617

Eastern : 8<sup>th</sup> Floor, Plot No 7/7 & 7/8, CP Block, Sector V,  
Salt Lake, Kolkata, West Bengal 700091

{ 2367 0012  
{ 2320 9474

Northern : Plot No. 4-A, Sector 27-B, Madhya Marg,  
Chandigarh 160019

{ 265 9930

Southern : C.I.T. Campus, IV Cross Road, Taramani, Chennai 600113

{ 2254 1442  
{ 2254 1216

Western : 5<sup>th</sup> Floor/MTNL CETTM, Technology Street, Hiranandani Gardens, Powai  
Mumbai 400076

{ 25700030  
{ 25702715

**Branches :** AHMEDABAD, BENGALURU, BHOPAL, BHUBANESHWAR, CHANDIGARH, CHENNAI, COIMBATORE, DEHRADUN, DELHI, FARIDABAD, GHAZIABAD, GUWAHATI, HARYANA (CHANDIGARH), HUBLI, HYDERABAD, JAIPUR, JAMMU, JAMSHEDPUR, KOCHI, KOLKATA, LUCKNOW, MADURAI, MUMBAI, NAGPUR, NOIDA, PARWANOO, PATNA, PUNE, RAIPUR, RAJKOT, SURAT, VIJAYAWADA.