

यांत्रिक कंपन — सक्रिय चुंबकीय बियरिंग्स
से युक्त घूर्णन मशीनरी का कंपन
भाग 2 कंपन का मूल्यांकन

**Mechanical Vibration — Vibration of
Rotating Machinery Equipped with
Active Magnetic Bearings
Part 2 Evaluation of Vibration**

ICS 17.160

© BIS 2024
© ISO 2004



भारतीय मानक ब्यूरो
BUREAU OF INDIAN STANDARDS
मानक भवन, 9 बहादुर शाह ज़फर मार्ग, नई दिल्ली - 110002
MANAK BHAVAN, 9 BAHADUR SHAH ZAFAR MARG
NEW DELHI - 110002
www.bis.gov.in www.standardsbis.in

NATIONAL FOREWORD

This Indian Standard (Part 2) which is identical with ISO 14839-2 : 2004 'Mechanical vibration — Vibration of rotating machinery equipped with active magnetic bearings — Part 2: Evaluation of vibration' issued by the International Organization for Standardization (ISO) was adopted by the Bureau of Indian Standards on the recommendation of the Bearings Sectional Committee and approval of the Production and General Engineering Division Council.

This standard sets out general guidelines for measuring and evaluating rotating machinery equipped with active magnetic bearings (AMBs) with respect to the shaft vibratory displacement measured at the AMBs, and the working current and voltage measured in magnetic coils or power supply amplifiers.

This standard is published in five parts. Other parts in this series are:

- Part 1 Vocabulary
- Part 3 Evaluation of stability margin
- Part 4 Technical guidelines
- Part 5 Touch-down bearings

The text of ISO standard has been approved as suitable for publication as an Indian Standard without deviations. Certain conventions are, however, not identical to those used in Indian Standards. Attention is particularly drawn to the following:

- a) Wherever the words 'International Standard' appear referring to this standard, they should be read as 'Indian Standard'; and
- b) Comma (,) has been used as a decimal marker while in Indian Standards, the current practice is to use a point (.) as the decimal marker.

In this adopted standard, reference appears to the following International Standard for which Indian Standard also exist. The corresponding Indian Standard which is to be substituted in its place is listed below along with its degree of equivalence for the edition indicated:

<i>International Standard</i>	<i>Corresponding Indian Standard</i>	<i>Degree of Equivalence</i>
ISO 7919-1 Mechanical vibration of non-reciprocating machines — Measurements on rotating shafts and evaluation criteria — Part 1: General guidelines	IS/ISO 20816-1 : 2016 Mechanical vibration — Measurement and evaluation of machine vibration: Part 1 General guidelines	Identical

In reporting the result of a test or analysis made in accordance with this standard, if the final value, observed or calculated, is to be rounded off, it shall be done in accordance with IS 2 : 2022 'Rules for rounding off numerical values (*second revision*)'.

Contents

	Page
1 Scope	1
2 Normative references	1
3 Measurement and evaluation procedures	1
4 Evaluation criteria	6
Annex A (informative) Case study on an LP centrifugal compressor equipped with active magnetic bearings (AMBs)	8
Annex B (informative) Case study on current evaluation	14
Annex C (informative) Voltage saturation	17
Bibliography	20

Introduction

This part of ISO 14839 concerns steady-state values of rotor vibrations and the AMB coil currents and voltage measured during nominal steady-state operation, but not the transient condition while passing critical speeds. The regulations of these transient vibrations passing at the critical speeds are established in ISO 10814 in which the modal sensitivity, the so-called amplification factor (Q-factor), is then evaluated. This topic is beyond the scope of this part of ISO 14839.

Because of the stiff support of oil-film bearings with small clearances [e.g. bearing radial clearance (C) divided by the journal radius (R), $C/R \approx 0,001$], shaft vibration should be regulated within low levels to avoid oil-film rupture of the lubricant and metal contact inside the bearing. In contrast, the relatively soft support of AMBs and correspondingly large clearances (e.g. $C/R \approx 0,005$), a larger vibration level is often observed in AMB rotors, but is quite normal and acceptable. The lower stiffness introduces no major problems in the transmission force to the machine foundation. Compared to the oil-film bearing rotor standards (see the ISO 7919-1 series), this part of ISO 14839 provides greater values of zone limits for vibration assessment and acceptance.

Indian Standard

**MECHANICAL VIBRATION — VIBRATION OF ROTATING
MACHINERY EQUIPPED WITH ACTIVE MAGNETIC BEARINGS
PART 2 EVALUATION OF VIBRATION**

1 Scope

This part of ISO 14839 sets out general guidelines for measuring and evaluating rotating machinery equipped with active magnetic bearings (AMBs) with respect to the following two indices:

- shaft vibratory displacement measured at or close to the AMBs, and
- working current and voltage measured in magnetic coils or power supply amplifiers.

Both indices are measured under nominal operating conditions in house and/or on site. These guidelines are presented in terms of both steady-state running values of these indices and any magnitude changes which may occur in these steady-state operations.

This part of ISO 14839 is applicable to industrial rotating machines generating or consuming nominal power greater than 15 kW, and is not limited by size or operational rated speed (i.e. comprising turbo-compressors, turbo-pumps, steam turbines, turbo-generators, turbo-fans, electric drives and other rotors supported by AMBs). This part of ISO 14839 establishes the vibration, current and voltage evaluation of the rotating machinery equipped with AMBs, specified by a comparatively large power capacity as described above, excluding small-scale rotors such as turbo-molecular pumps, spindles and flywheels.

This part of ISO 14839 covers both AMB-equipped rigid rotors and AMB-equipped flexible rotors.

2 Normative references

The following referenced documents are indispensable for the application of this document. For dated references, only the edition cited applies. For undated references, the latest edition of the referenced document (including any amendments) applies.

ISO 7919-1, *Mechanical vibration of non-reciprocating machines — Measurements on rotating shafts and evaluation criteria — Part 1: General guidelines*

3 Measurement and evaluation procedures

3.1 Description of rotor-AMB system

A typical rotor system supported by AMBs is illustrated in Figure 1. An AMB is located at each end of the shaft and includes an adjacent displacement transducer and an emergency (auxiliary) ball bearing. The axial AMB is omitted in this figure. The control network for driving the AMB device is shown in Figure 2. As shown in these figures, each displacement transducer detects the shaft journal position at the bearing locations and its signal is fed back to the controller. Deviation from the bearing centre is delivered to the controller. This controller might, for example, implement a proportional, integral and differential actions (PID) control algorithm. The controller drives the power amplifiers to supply the coil current. If the shaft moves downward, the upper electromagnetic coil is activated to lift the rotor upward by the magnetic force. Since, in this manner, the magnetic force acts

upon the shaft so as to maintain the shaft at the neutral position inside the bearing, the AMB accomplishes both levitation and vibration control without mechanical contact.

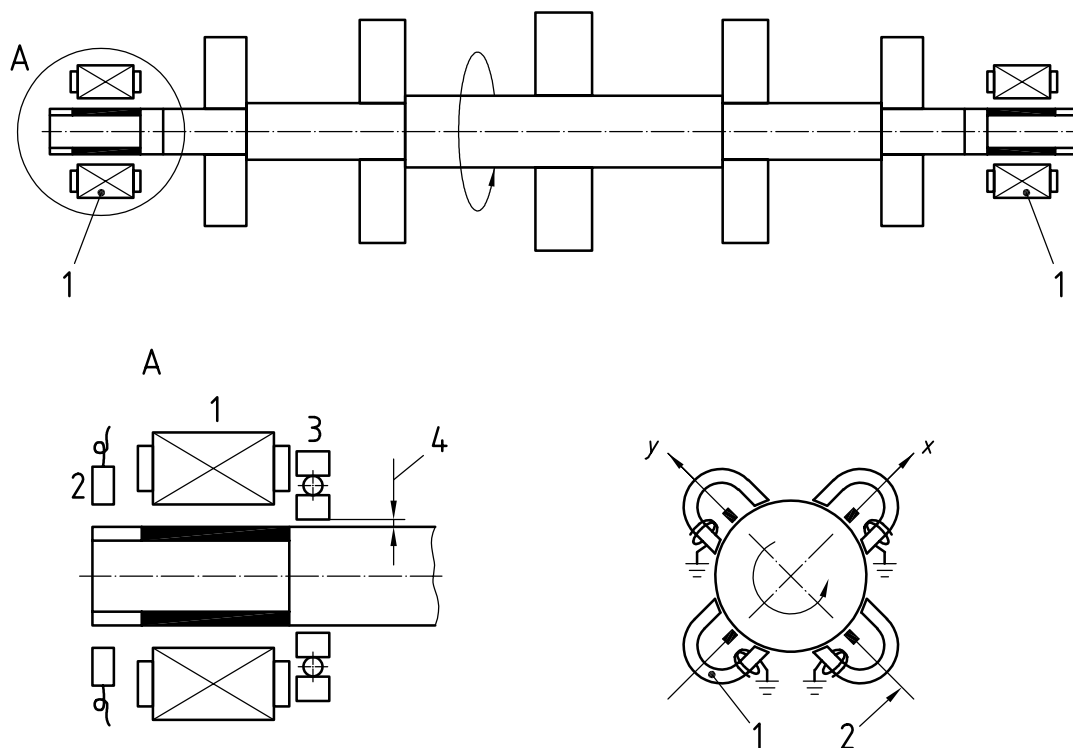

Key

- 1 AMB
- 2 displacement transducer
- 3 touch-down bearing
- 4 clearance

Figure 1 — Rotor system equipped with active magnetic bearings

3.2 Displacement

Throughout this part of ISO 14839, the term “vibratory displacement” refers to the total displacement of the shaft from the bearing’s centre, including any static displacement. The vibration measurement of the stationary parts of the machine (e.g. bearing housing) is excluded from this part of ISO 14839.

AMB equipment in rotating machines has its own displacement transducers for detecting shaft movement, $x(t)$ and $y(t)$, as shown in Figure 3. No additional displacement transducers are required. The detected values of shaft vibratory position by these displacement transducers is the subject of this part of ISO 14839.

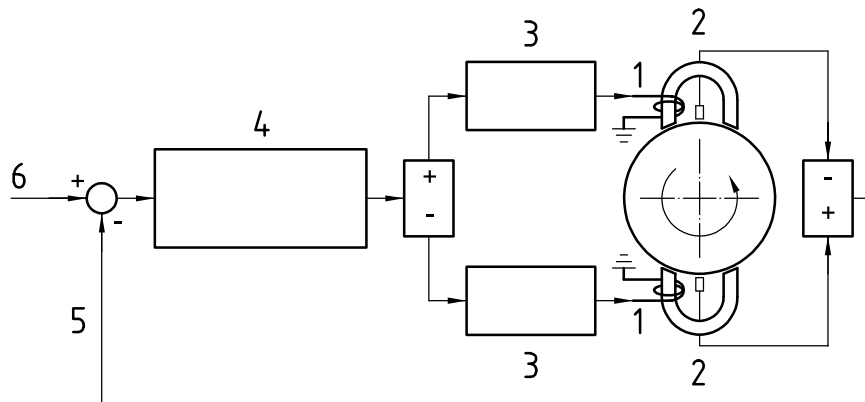

Key

- 1 AMB
- 2 displacement transducer
- 3 power amplifier
- 4 controller
- 5 journal position signal
- 6 reference signal

Figure 2 — Layout of AMB control network

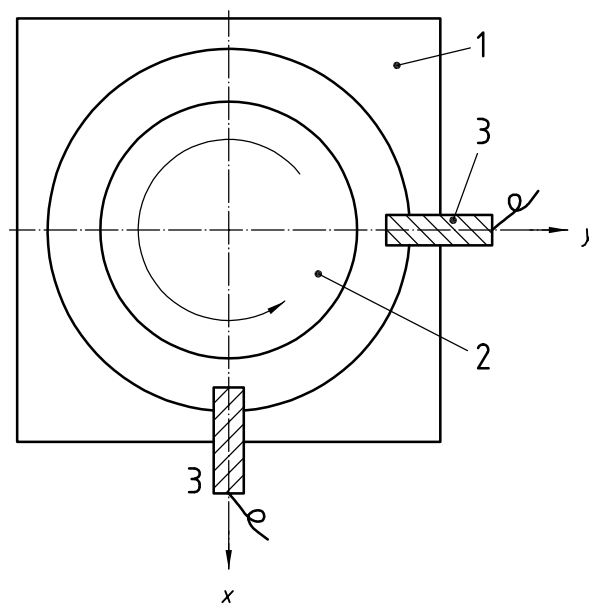

Key

- 1 casing
- 2 shaft
- 3 displacement transducers

Figure 3 — Displacement transducers of AMBs

As shown in Figure 3, the displacement transducers are oriented in the x and y directions at each radial bearing. The signals from these displacement transducers indicate the rotor journal position including the d.c. component (eccentricity) and a.c. component (vibration orbit) as shown in Figure 4. Eccentricities from the clearance centre of the AMB (designated O–O_i) in the x and y directions are designated $\varepsilon_x, \varepsilon_y$, while the vibration orbit amplitudes in the x and y directions are designated a_x, a_y . The maximum displacement of the rotor from the clearance centre of the radial AMB, designated D_{\max} , can be calculated from Equation (1) exactly

$$D_{\max} = \max \left[\sqrt{x^2(t) + y^2(t)} \right] \quad (1)$$

or approximated by Equation (2), based on the orbit observation:

$$D_{\max} \approx \sqrt{x_{\max}^2 + y_{\max}^2} \quad (2)$$

where

$$x_{\max} = \varepsilon_x + a_x$$

$$y_{\max} = \varepsilon_y + a_y$$

This formula to estimate the maximum displacement in a certain direction will generally overestimate the exact value with a maximum error of approximately 40 %.

The evaluation of D_{\max} from Equation (1) and (2) using the signals measured by two displacement transducers is relatively complex. A digital oscilloscope or other special instrument is required. As a simpler procedure, the maximum value of the displacement values measured in two orthogonal directions is recommended as shown in Figure 4, based on the waveform observation:

$$D_{\max} \geq \max[x_{\max}, y_{\max}] \quad (3)$$

This equation will, in general, underestimate the displacement.

Any of these three displacement quantities may be agreed upon as the method of characterizing the maximum displacement D_{\max} . In order to avoid contact problems between the rotor and stators, the following formula should be satisfied with a certain margin against the minimum radial clearance $C_{\min\text{-radial}}$:

$$D_{\max} < C_{\min\text{-radial}} \quad (4)$$

This D_{\max} is the index used to evaluate the clearance margin in this part of ISO 14839.

For assessment in this part of ISO 14839, the axial movement, z , of the rotor is measured to compare with the minimum axial clearance $C_{\min\text{-axial}}$ in the same manner as shown in Figure 4. In this case:

$$D_{\max} = z_{\max} < C_{\min\text{-axial}} \quad (5)$$

These measurements considering the radial and axial directions should be made under agreed conditions over the operational speed and load ranges of the machine. These measurements should typically be made after achieving agreed thermal and operating conditions. It should be noted that these D_{\max} indexes are measured only for the specified steady-state conditions including nominal slow changes in load. In addition, measurements may also be taken when different conditions exist or during transient changes, for example, during slow roll, warming-up speed, critical speeds or shut down. However, the result of these measurements may not be suitable for this evaluation.

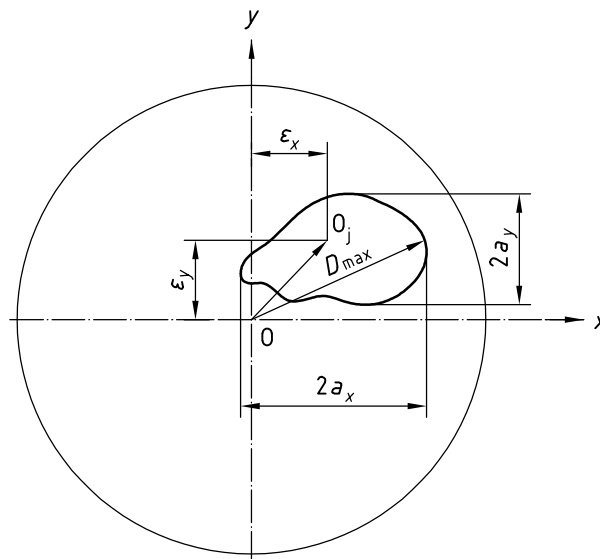

a) Orbit

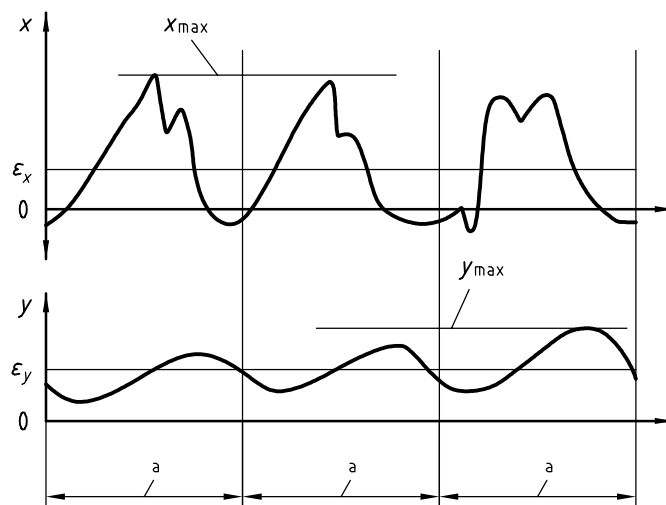

b) Vibration time history

- a is the vibration orbit amplitude
- t is the time
- ε is the eccentricity from the clearance centre
- ^a Time for one revolution.

Figure 4 — Unfiltered shaft orbit and vibration time history

3.3 Coil current and voltage

At the time of publication of this part of ISO 14839, there are not enough data to define a criterion that guarantees the reliable operation of the electrical part of the AMB system concerning the working current and voltage in the coils. These parameters are thus not put into the evaluation, but the corresponding information is stated as guidelines in Annexes A to C.

4 Evaluation criteria

4.1 General

Two evaluation criteria are used to assess the journal displacement of AMBs. One criterion considers the magnitude of the observed displacement; the second considers changes in magnitude, irrespective of whether they are increases or decreases.

4.2 Criterion I

Reliable operation of AMB machines requires satisfaction of Equations (4) and (5) to avoid contact between rotating and stationary parts of a machine (e.g. at AMB stators, adjacent displacement transducers, touch-down bearings or labyrinth seals). The minimum radial clearance, C_{\min} , can be defined by the minimum gap when statically moving the rotor in any radial direction. The touch-down bearing gap is generally set to be C_{\min} by design.

In the case of AMBs, this criterion is concerned with defining limits only for the journal displacement to maintain the running clearance margin. Other concerns with bearing dynamic load and the transmitted force to stationary structures, as stated in ISO 7919-1, are excluded due to the comparably soft and non-contact support of AMBs rather than oil-film bearings. Therefore, the speed dependency of the limit values does not exist in this part of ISO 14839 and these limit values shall be constant in the whole range of rated speeds.

ISO 7919-1 establishes vibration zone guidelines for oil-film bearings. The definitions of each zone are as follows.

Zone A: The vibratory displacement of newly commissioned machines would normally fall within this zone.

Zone B: Machines with vibratory displacement within this zone are normally considered acceptable for unrestricted long-term operation.

Zone C: Machines with vibratory displacement within this zone are normally considered unsatisfactory for long-term continuous operation. Generally, the machine may be operated for a limited period in this condition until a suitable opportunity arises for remedial action.

Zone D: Vibratory displacement within this zone is normally considered to be sufficiently severe to cause damage to the machine.

The corresponding zone table for magnetic bearings, established from international experience, is given in Table 1. The corresponding graphical descriptions are provided in Figure 5.

These values are not intended to serve as an acceptance specification on either a test stand or the commissioning installation. The acceptance specification shall be subject to agreement between the machine manufacturer and customer. However, the values in Table 1 provide guidelines for ensuring that gross deficiency or unrealistic requirements are avoided. The values in Table 1 may also provide guidance for condition monitoring, problem diagnosis and for setting operating limits. It should be noted that general information on alarm and trip operating limits is stated in ISO 7919-1.

Table 1 — Recommended criteria of zone limits

Zone limit	Displacement D_{max}
A/B	$< 0,3 C_{min}$
B/C	$< 0,4 C_{min}$
C/D	$< 0,5 C_{min}$

NOTE C_{min} is the minimum value of radial or axial clearance between rotor and stator.

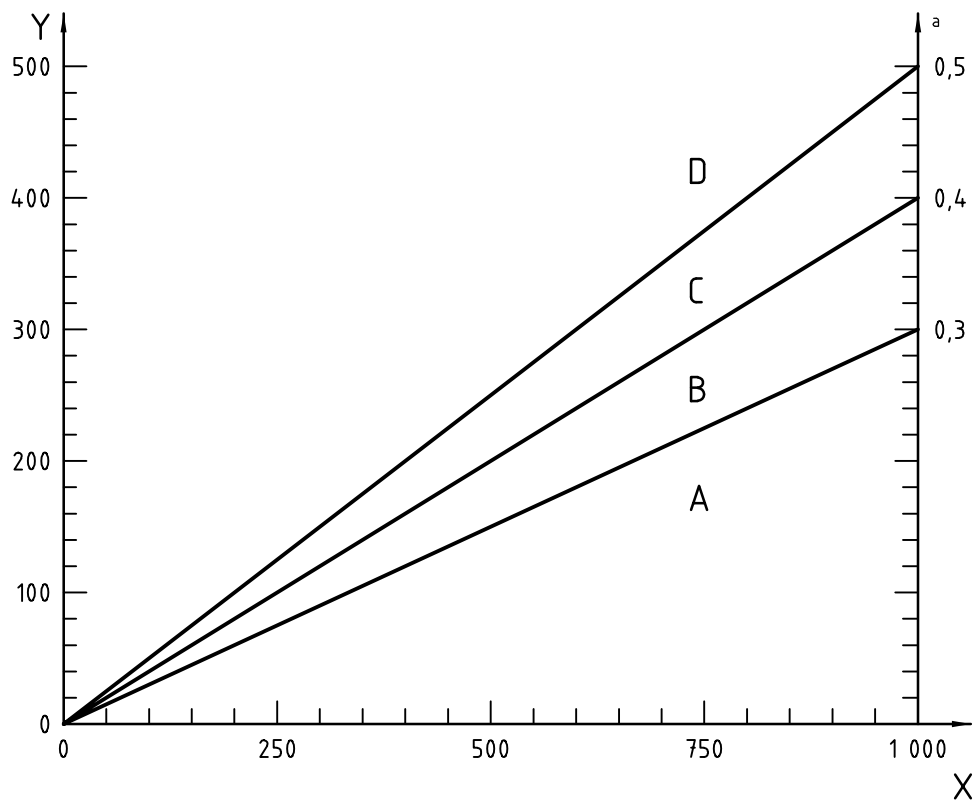

Key

X minimum radial clearance, C_{min} , in micrometres
Y maximum peak displacement, D_{max} , in micrometres

^a Ratio D_{max}/C_{min} .

Figure 5 — Zone limits for vibration criteria

4.3 Criterion II

This criterion provides an assessment of the change in the vibration magnitudes from a baseline. A significant change in broad-band magnitude may occur which would require some action even though zone C of Criterion I has not been reached. Such changes can be progressive with time or instantaneous, and may point to incipient damage or some other irregularity.

Criterion II is specified on the basis of the change in broad-band magnitude occurring under steady-state operating conditions. When Criterion II is applied, it is essential that the measurements being compared be taken under approximately the same machine operating conditions. Significant changes from the normal magnitudes should be regulated to less than 25 % of the upper boundary value of zone B, as defined in Table 1, because a potentially serious fault may be indicated. When the change in the magnitudes is beyond this criterion, the reason for the change shall be determined, and any further action required shall be decided.

Annex A (informative)

Case study on an LP centrifugal compressor equipped with active magnetic bearings (AMBs)

A.1 LP centrifugal compressor

The characteristics of a low-pressure (LP) compressor supported by AMBs are used as an example. The compressor geometry is shown in Figure A.1, including eigen mode shapes obtained by assuming average values of the AMB supporting stiffness. The LP compressor has seven stage impellers with a rotor mass of 780 kg. The design specification for this process compressor is shown in Table A.1. The rated speed is 10 900 r/min (182 Hz), with a nominal shaft power of 4 120 kW.

The AMB specification is shown in Table A.2. These radial AMBs are specified by $D/L = 0,98$, $C/R = 0,006\ 8$, where the AMB journal length $L = 150$ mm, journal diameter $D = 147$ mm, radial clearance $C = 500\ \mu\text{m}$, radius $R = D/2$.

Note that the radial clearance of the auxiliary bearing, $230\ \mu\text{m}$, is set at about half the AMB clearance to prevent emergency contacts of the AMB itself. Therefore, the minimum radial clearance $C_{\text{min}} = 230\ \mu\text{m}$ is applicable in accordance with this part of ISO 14839.

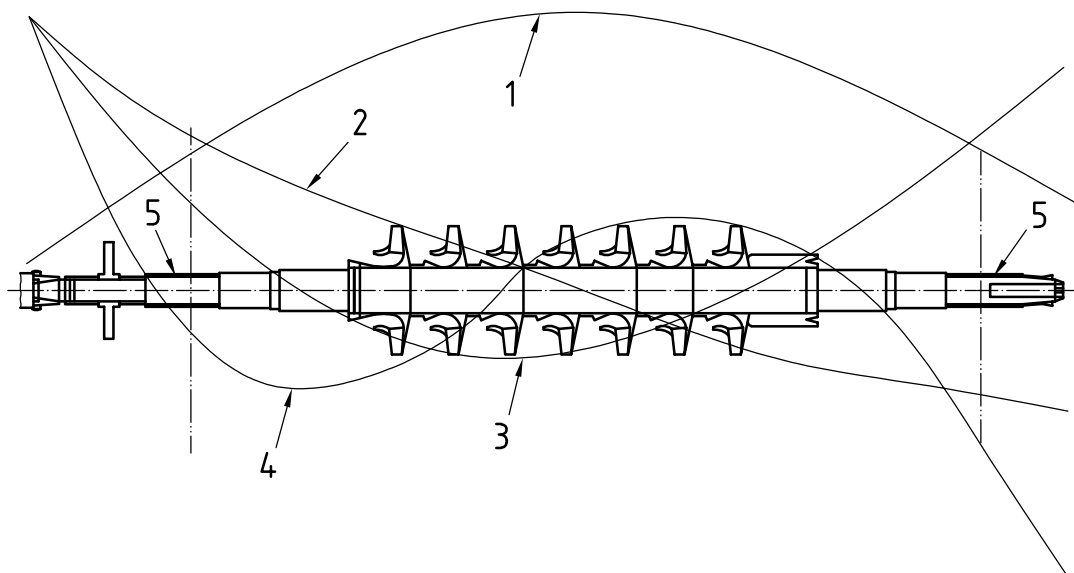

Key

- 1 first eigen mode
- 2 second eigen mode
- 3 third eigen mode
- 4 fourth eigen mode
- 5 AMB

NOTE The operational speed N is set between the 3rd and 4th critical speeds. The AMB locations are offset from the nodes of each eigen mode to maintain sufficient controllability.

Figure A.1 — Eigen mode shapes of LP rotor

Table A.1 — Compressor design specification

Service	LP casing	HP casing
Model	MCH 527	MCH 508
Gas	Enriched H ₂	
Flow	43 691 m ³ /h	43 486 m ³ /h
Suction pressure	0,33 MPa	0,79 MPa
Discharge pressure	0,91 MPa	2,03 MPa
Rated rotational speed, N	10 900 r/min = 182 Hz	
Operational speed range	9 625 r/min to 11 445 r/min	
Shaft power	4 120 kW	
Driver rating	5 300 kW	

Table A.2 — AMB specification

	LP	HP
Radial bearing		
Diameter, D	147 mm	147 mm
Length, L	150 mm	150 mm
Load	3 822 N	4 557 N
Capacity	10 340 N	10 340 N
Clearance, C	500 μm	500 μm
Radial auxiliary bearing		
Clearance, C	230 μm	230 μm

A.2 Critical speed layout

One of the most important aspects for designing flexible rotors is the critical speed layout. The rotodynamic behaviour of machines supported by AMBs is significantly different from that of machines with oil-film bearings. This can be understood more clearly by calculating a critical speed versus bearing stiffness map for the LP rotor and plotting on non-dimensional axes as shown in Figure A.2. The vertical axis is the natural frequency normalized by the frequency of the first free-free bending mode. The horizontal axis indicates the bearing stiffness normalized by the shaft stiffness. Typical bearing stiffness curves for oil-film bearings and for magnetic bearings are also plotted in Figure A.2.

The stiffness of oil-film bearings is typically high relative to the shaft stiffness as shown in Figure A.2. A compressor is typically considered to be supercritical if its operating speed is above N_{C1} , for instance if the operating speed range falls between N_{C1} and N_{C2} within a certain margin as indicated by the B2 region. Thus, the first and second critical speeds are marked by the intersections between the first two eigen frequency curves and the oil-film bearing stiffness, noted N_{C1} and N_{C2} , respectively.

The stiffness of AMBs is typically low relative to the shaft stiffness. A compressor is typically considered to be supercritical if its operating speed is above N_{C3} , for instance if the operating speed range falls between N_{C3} and N_{C4} within a certain margin as indicated in Figure A.2 by the region A2.

A typical unbalance response curve of an AMB-equipped flexible rotor is illustrated in Figure A.3. The unbalance resonance vibration peaks appear at N_{C1} , N_{C2} , N_{C3} and N_{C4} . The first two modes correspond to the rigid-mode critical speeds, i.e. parallel and conical modes, and the third critical speed N_{C3} is the first free-free bending mode frequency. The operational speed N is thus set in the range between the third (N_{C3}) and fourth (N_{C4}) critical speeds.

The critical speeds N_{C1} , N_{C2} and N_{C3} require a sufficient damping level to pass the resonance speeds. The vibration magnitude and the resonance severity of these critical speeds are regulated by ISO 10814, which is out of the scope of this part of ISO 14839.

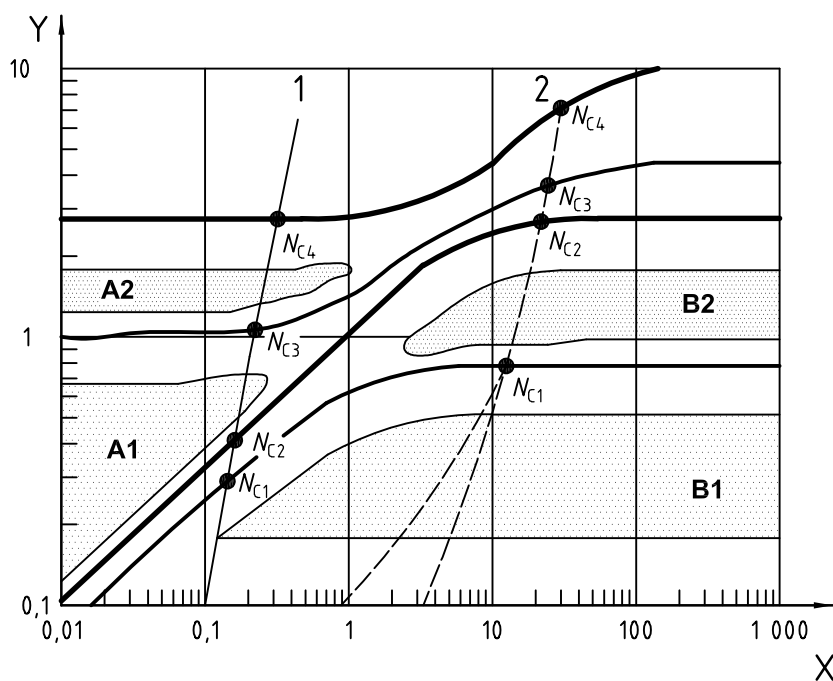

Key

- 1 AMB
- 2 oil-film bearing
- X ratio of bearing stiffness to shaft stiffness
- Y ratio of natural frequency to first free-free frequency

NOTE The critical speeds, N_{Ci} , are defined by intersections between natural frequency curves and bearing stiffness curves of oil-film bearing and AMB. The possible operational speeds are set separately from these critical speeds to allow certain margins, as indicated by shaded regions.

Figure A.2 — Typical critical speed map of a uniform shaft being equivalent to an LP rotor

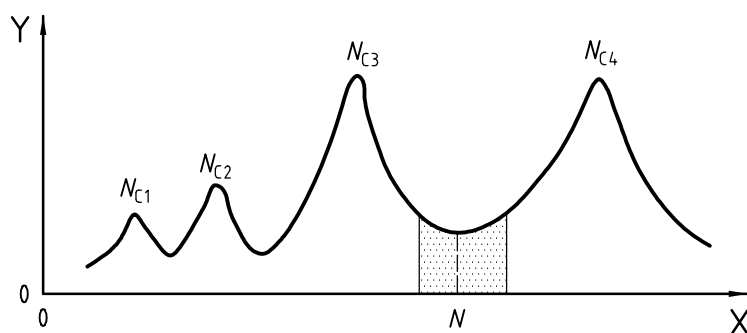

Key

- X rotational speed
- Y peak vibratory displacement

NOTE The shaded area indicates the operational speed range with rated rotational speed N .

Figure A.3 — Unbalance response curve

A.3 In-house rotation test results

The LP compressor was required to satisfy a shop performance test in accordance with ASME PTC 10 and the mechanical run test in accordance with ISO 10439. The test results at the final phase of the mechanical run done at the shop are shown in Figure A.4, as unbalance response curves. Due to precise rotor balancing, the maximum unbalance vibration has a peak value D_{\max} of less than $10\ \mu\text{m}$. Though this value is generally still larger than that of the oil-film bearing compressors, it is quite normal for AMB compressors.

According to Table 1, this evaluation result indicates the zone A, since for the ratio of the peak vibratory displacement to minimum clearance:

$$D_{\max}/C_{\min} = 10\ \mu\text{m}/230\ \mu\text{m} < 0,3.$$

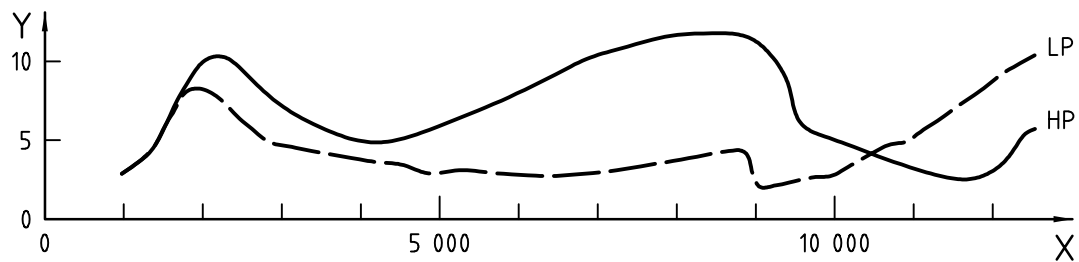

Key

- X rotational speed, r/min
- Y peak vibratory displacement, μm

Figure A.4 — Unbalance response curves from mechanical run of low-pressure (LP) and high-pressure (HP) rotors

A.4 Vibration data on site

This machine has been in continuous operation since it was commissioned on site. This includes scheduled maintenance every six months without any major problems. An example of the field data measured on site is shown in Figure A.5, showing that the peak vibratory displacement D_{\max} is less than $30\ \mu\text{m}$. The bar chart shown in Figure A.6 indicates the examples of steady-state data under normal operation conditions.

Measured vibration values are low enough in comparison with the minimum radial clearance $C_{\min} = 230\ \mu\text{m}$. According to Table 1, this evaluation result indicates the zone A since for the ratio of the peak vibratory displacement to minimum clearance:

$$D_{\max}/C_{\min} = 30\ \mu\text{m}/230\ \mu\text{m} < 0,3.$$

A.5 Current data on site

The working coil current is measured and the average current I_0 is monitored as shown by the bar chart in Figure A.6. The current (with unbalance force rejection control) showed an average of $I_0 = 35\ \text{A}$ for the current capacity $I_c = 60\ \text{A}$.

Since the average value I_0 of current was monitored, the dynamic component was not measured. However, it can be said that enough current margin is guaranteed due to the employment of the unbalance force rejection control (see Annex B).

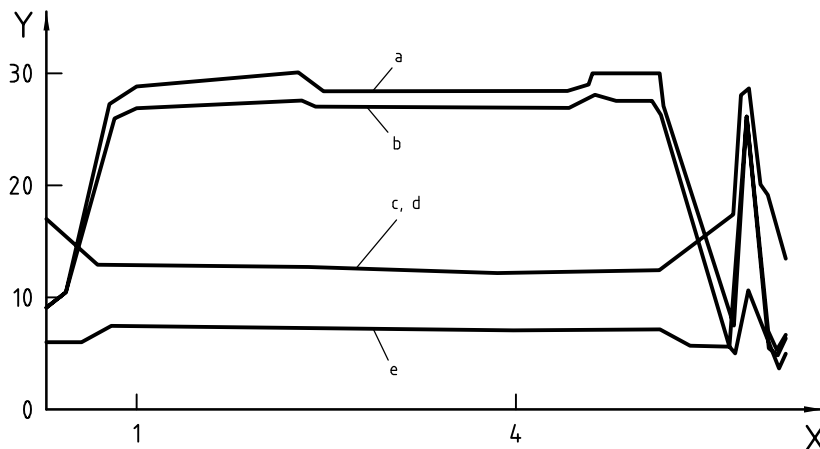

Key
 X time, h
 Y peak vibratory displacement, μm
 a-d Shaft radial vibration.
 e Axial vibration.

Figure A.5 — Field data of the LP rotor (during start-stop)

A.6 Comparison with other standards to be applied to oil-film bearings

The peak-to-peak displacement value on site is about $60 \mu\text{m}$ (twice the maximum peak value D_{max}) for the AMB-equipped compressor considered in the example (see Figure A.5). If these vibration data are evaluated by conventional criteria assuming oil-film bearings, the judgement will be different, as follows.

a) ISO 7919-3 provides for this compressor the judgement of zone B with peak-to-peak displacement $S_{\text{p-p}}$:

$$\text{Zone A: } S_{\text{p-p}} = 4\,800 \sqrt{N} = 45 \mu\text{m}$$

$$\text{Zone B: } S_{\text{p-p}} = 9\,000 \sqrt{N} = 84 \mu\text{m}$$

where $N = 11\,445 \text{ r/min}$ is the upper limit of the operational speed range.

b) According to the criteria in ISO 10439 regarding centrifugal compressors, this compressor is not accepted by the following assessment for the peak-to-peak displacement value L_v :

$$L_v = \left\{ 25,4 \sqrt{\frac{12\,000}{N_{\text{MCS}}}} = \sqrt{\frac{12\,000}{11\,445}} = 26,6 \text{ and } \leq 25,4 \right\} = 25,4 \mu\text{m}$$

where $N_{\text{MCS}} = 11\,445 \text{ r/min}$ is the maximum continuous speed.

As seen in these examples, the conventional standards for oil-film bearing rotors are not suitable for AMB rotors. Therefore, this part of ISO 14839 should be used when setting guidelines for the performance of AMB machines.

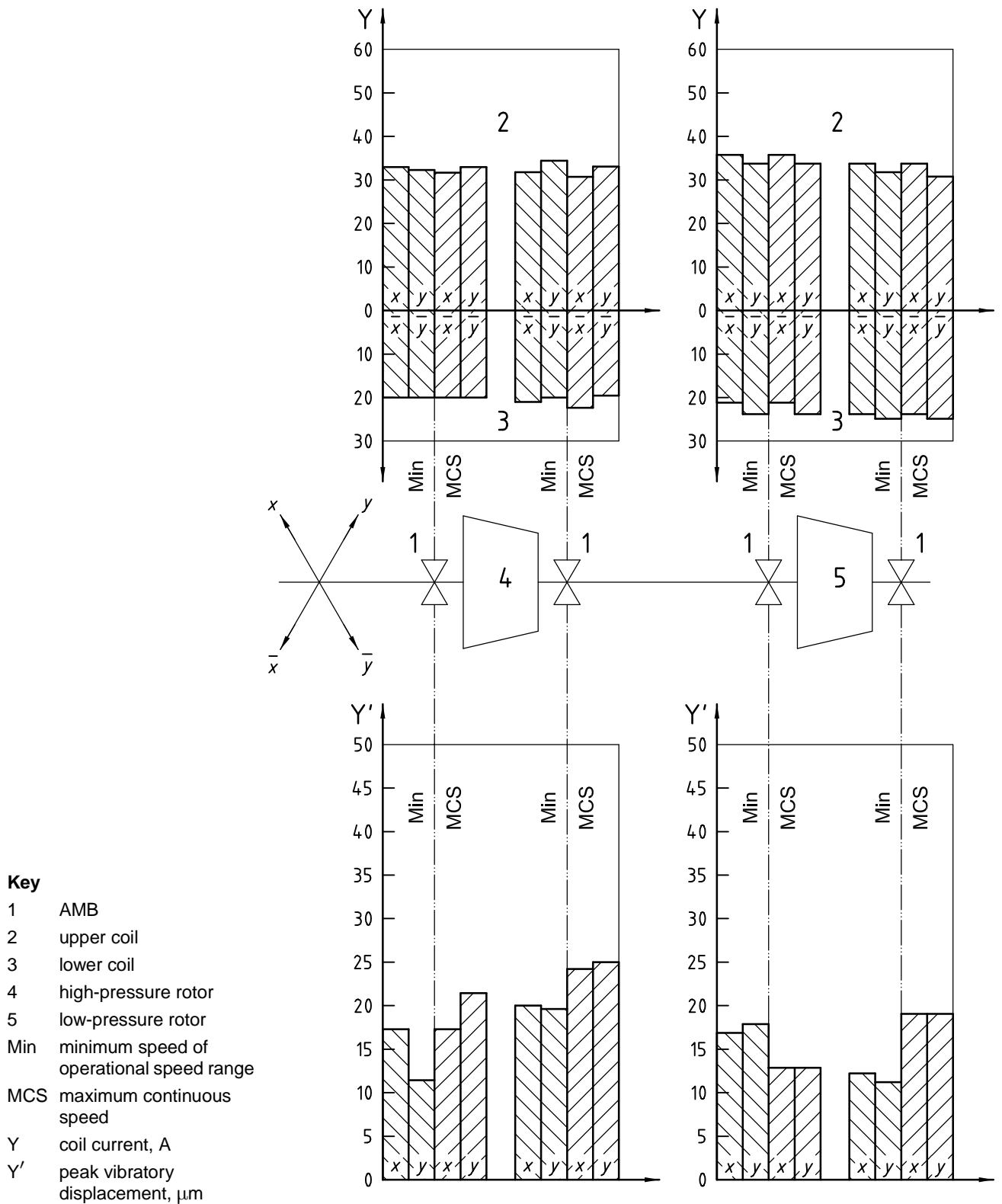

NOTE The power amplifiers work as the A-class specification by providing the constant current of 30 A to the upper and lower directional coils. The difference between these upper and lower coil currents is for the rotor levitation.

Figure A.6 — Field data (vibration and current)

Annex B (informative)

Case study on current evaluation

B.1 Current measurement

A power amplifier supplies current in the AMB coils corresponding to the control command as indicated in Figure 2. An example of a detailed schematic layout of a PWM (pulse width modulation) power amplifier is provided in Figure B.1. The input of the control command regulates the flow of current $I(t)$ from the power source to the electromagnetic coil L. This current can be monitored by the feedback loop:

$$I(t) = V_f(t)/R_f$$

where

$V_f(t)$ is the feedback voltage;

R_f is the feedback resistance.

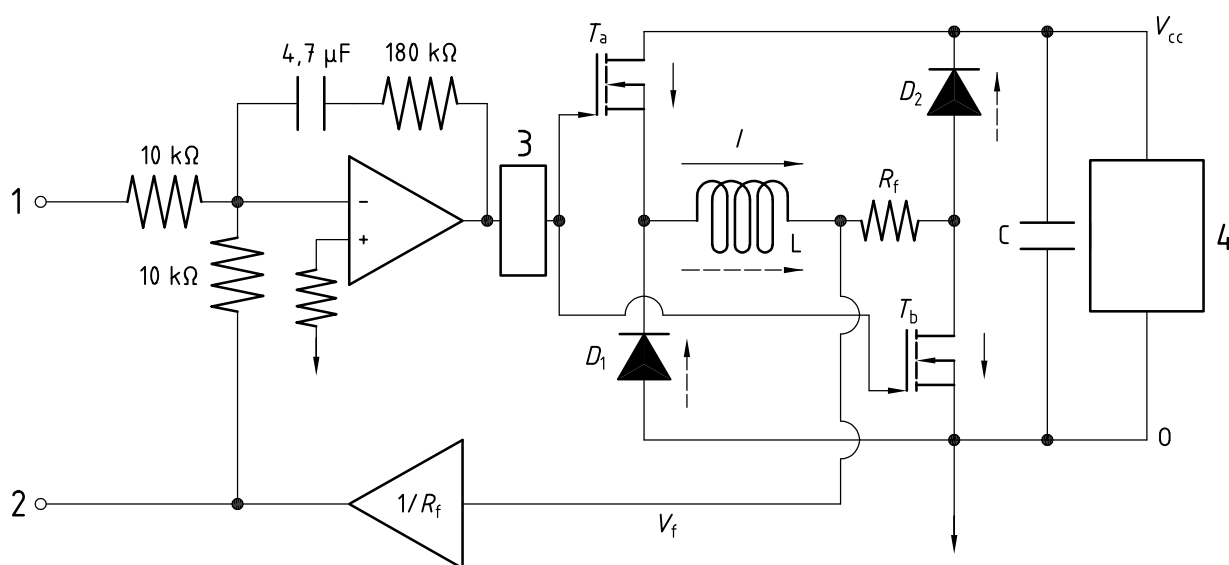

Key

- 1 control input
- 2 current monitor
- 3 PWM driver
- 4 d.c. power supply for the voltage V_{cc}

Figure B.1 — Pulse width modulation (PWM) power amplifier

This current monitor terminal of the PWM amplifier directly outputs the current waveform as shown in Figure B.2.

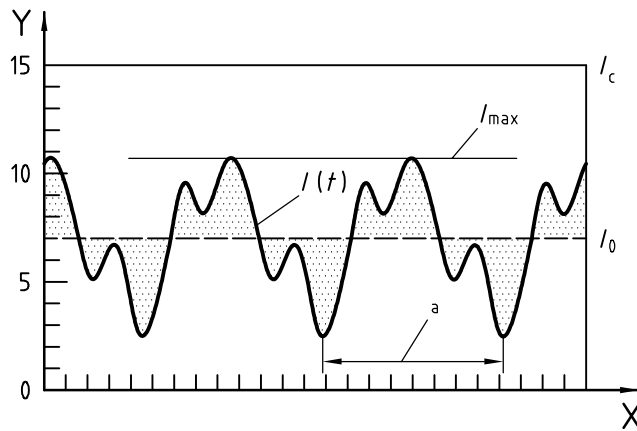

a) Without unbalance force rejection control

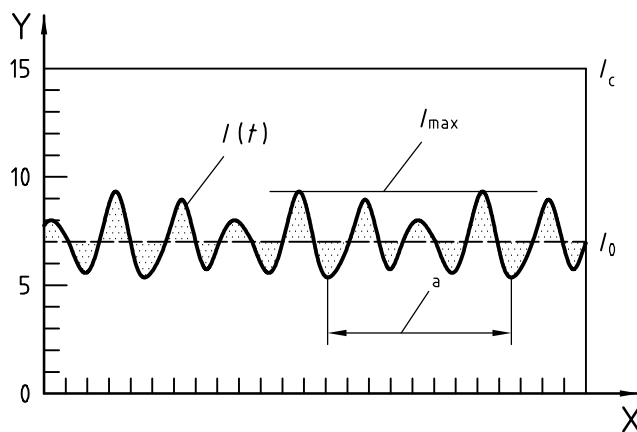

b) With unbalance force rejection control

Key

X time, t

Y current, I , A

^a Time for one revolution.

Figure B.2 — Current waveforms

If it is assumed that there is no rotor vibration, a nearly constant current should be observed at a certain level I_0 required for levitating the rotor, as shown by the horizontal dashed lines of Figure B.2. More typically, a dynamically varying current waveform $I(t)$ will be measured that includes response to control of rotor vibration, as shown by the solid lines of the figure. These current waveforms $I(t)$ are usually measured as in Figure B.2 a), i.e. without unbalance force rejection control. With unbalance force rejection control, the current waveform as in Figure B.2 b) is measured, excluding a synchronizing component with rotational speed.

In order to increase the accuracy of this current measurement, a filter with a cut-off frequency, for instance, which is greater than twice the rotor rotational speed, can be used.

B.2 Current evaluation

The maximum value, I_{\max} , of the current waveform $I(t)$ measured in magnetic coils during the rated operation is the index to be evaluated according to

$$I_{\max} = \max[I(t)] < I_c$$

where I_c is the current capacity of the power amplifier.

Every coil current should be checked against this criterion.

Annex C (informative)

Voltage saturation

C.1 General

In addition to vibration, there are other important quantities which should be kept within acceptable ranges. The most important quantities are temperature in the actuators and electronics, coil currents and amplifier control voltages. The temperature is an important factor affecting the reliability of the system. Also, it is clear that high coil currents indicate that the bearing load capacity is reached. On the other hand, the effects of the voltage saturation are not so obvious. Heavy saturation may lead to a situation where the radial vibration is small, but the machine is actually in the boundary of the safe operation and an unpleasant rotor dynamic behaviour may suddenly occur.

This annex is concentrated on the voltage saturation phenomenon and the effects associated with that. No threshold limits are given because the tolerated level of saturation depends on the application, control system design and the reason for the saturation. However, the key point is that the AMB vendor should take these aspects into consideration in the design and testing, and guarantee that the system is free of the pitfalls described in this annex. The pitfalls are mainly avoided by a proper design. However, it is often necessary to verify that the amplifier voltages remain under a sufficiently low level by testing the actual machine. Furthermore, in some cases on-line saturation monitoring is needed to guarantee safe operation in alternating operation conditions.

C.2 Operation of the amplifier

Switching amplifiers typically drive the coil current of an AMB. Such an amplifier is shown in Figure C.1. A reference value for a coil current is computed by a position control algorithm and the amplifier controls the actual current as close to the reference value as possible. The switching frequency of the amplifier is of the order of tens of kilohertz. The power switches (S1, S2) are typically power MOSFETs or IGBTs. The operation is such that when the switches are conducting, voltage over the coil is d.c. link voltage and the current is increasing with a slope defined by d.c. link voltage and coil inductance. When the switches are non-conducting, the voltage is minus d.c. link voltage and the current is decreasing with the same slope. In the case when only one of the switches is conducting, the voltage over the coil is practically zero and the current stays constant.

The effective coil voltage is the average value of the coil voltage over one switching period. From Figure C.1, it is obvious that the effective coil voltage is limited between plus or minus d.c. link voltage, and the maximum current slope is limited accordingly. Thus, the current and the bearing force are limited at high frequencies by the d.c. link voltage (see Figure C.2).

In a normal operation, the slope of the reference current is less than the maximum slope that the amplifier can produce and the actual current follows the reference value. However, when a steeper slope is asked, the actual current no longer follows the reference but is delayed. This delay, i.e. phase shift, has a deteriorating effect on the bearing dynamics. In the following, different scenarios associated with the voltage saturation phenomenon are discussed.

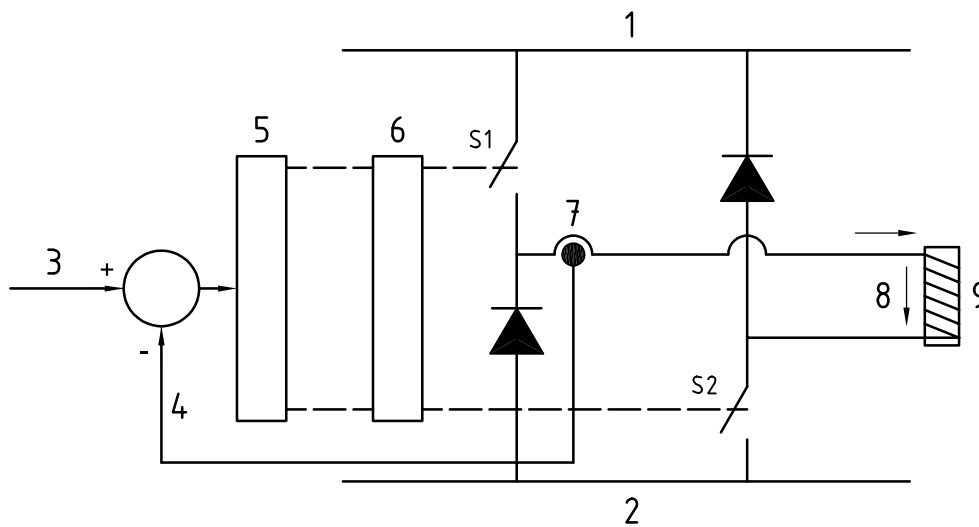

- Key**
- 1 d.c. link +
 - 2 d.c. link -
 - 3 reference current
 - 4 actual current
 - 5 control logic
 - 6 gate driver
 - 7 current measurement
 - 8 coil voltage
 - 9 electromagnet
 - S1, S2 power switches

Figure C.1 — Pulse width modulation (PWM) amplifier

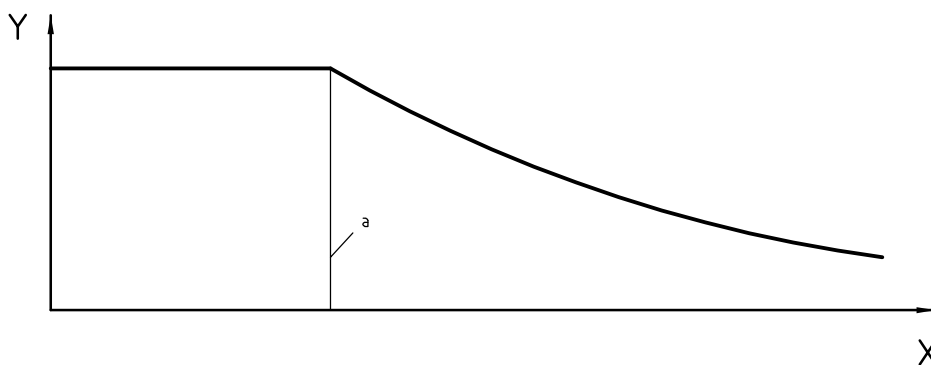

- Key**
- X frequency (linear scale)
 - Y maximum bearing force (linear scale)
 - ^a Knee frequency.

NOTE Below the knee frequency, the load capacity is limited by the magnetic circuit saturation and amplifier current limit. Above the knee frequency, the load capacity is limited by the d.c. link voltage. The slope is inversely proportional to the frequency.

Figure C.2 — AMB load capacity as a function of frequency

C.3 High-frequency disturbance saturating the amplifier

A large-amplitude disturbance signal at a high frequency leads to voltage saturation. Bearing dynamics deteriorate because a heavily saturated amplifier causes phase lag to signals of any frequency, not only for that signal that caused the saturation. Such a disturbance could be caused, for example, by a damaged transducer surface producing higher rotational harmonics, or simply an unbalanced rotor combined with an ineffective unbalance compensator. Furthermore, a frequency converter or some other external electric device can disturb an unshielded or otherwise low-quality AMB system and lead to voltage saturation. It should be noted that a well-designed AMB system tolerates a relatively high level of saturation before rotor dynamic instability occurs.

C.4 Rotor dynamic instability

One possible situation is that an incompatible control algorithm leads to instability of some rotor whirling mode or stator lateral mechanical resonance. Consequently, whirling or vibration amplitude increases until it is limited by the voltage saturation. Even if the amplitude would not be dangerously high, the saturated amplifier causes the rotor dynamic behaviour to deteriorate and, in the worst case, can even lead to instability of some other vibration modes. The risk of such a situation is eliminated by a proper control system design.

C.5 Large-amplitude instability

Another possible scenario is that the AMB operates well when disturbed by a small-amplitude disturbance. However, when larger disturbances are used, the system does not recover but starts oscillating. In testing, large-amplitude disturbances can be generated electrically using the diagnostic properties of the magnetic bearing or external function generator. Also, such disturbances can be generated using mechanical means, like hammering the rotor or stator with a rubber hammer. If the amplifier is too weak for the application, violent rigid-body vibration can result. There is a risk of such a situation when the unity gain frequency of the position control loop is above the knee frequency shown in Figure C.2 and the phase margins are not sufficient. A more realistic problem is that a large-amplitude disturbance leads to ringing of some elastic modes of the rotor or stator. The reason for this is the phase lag caused by the voltage saturation combined with too narrow phase margins in the control loop.

C.6 Critical speed passing

Passing of a bending critical speed can also lead to voltage saturation if the critical speed is at a higher frequency than the knee frequency shown in Figure C.2. Even a low level of saturation in this case can lead to rapidly increasing whirling amplitude. To avoid such a situation, there should be a monitoring system that ensures that the voltage saturation does not occur; i.e. the dynamic load capacity is not exceeded.

C.7 Measurement of voltage saturation

Basically, the effective coil voltage can be measured from the magnet connectors of the AMB controller using appropriate isolation and filtering circuits. However, a more elegant way is to measure it using the switch control signals coming from the control logic (see Figure C.1). The coil voltage can also be estimated from the reference current using a simple derivator circuit.

In the testing, the thus-obtained effective coil voltage can be viewed in the time domain and the conclusion of whether the situation is acceptable or not can be made from this signal plot. However, if an on-line monitoring system is used, it is better to generate a simpler index to describe the level of saturation. One index could be the maximum absolute value divided by the d.c. link voltage. Another possibility is to measure the relative time that the amplifier is in the saturated state over a period of time. By using such measures, an on-line voltage saturation monitoring can be realized.

Bibliography

- [1] ISO 7919-2, *Mechanical vibration — Evaluation of machine vibration by measurements on rotating shafts — Part 2: Land-based steam turbines and generators in excess of 50 MW with normal operating speeds of 1500 r/min, 1800 r/min, 3000 r/min and 3600 r/min*
- [2] ISO 7919-3, *Mechanical vibration of non-reciprocating machines — Measurements on rotating shafts and evaluation criteria — Part 3: Coupled industrial machines*
- [3] ISO 7919-4, *Mechanical vibration of non-reciprocating machines — Measurements on rotating shafts and evaluation criteria — Part 4: Gas turbine sets*
- [4] ISO 7919-5, *Mechanical vibration of non-reciprocating machines — Measurements on rotating shafts and evaluation criteria — Part 5: Machine sets in hydraulic power generating and pumping plants*
- [5] ISO 10439, *Petroleum, chemical and gas service industries — Centrifugal compressors*
- [6] ISO 10814, *Mechanical vibration — Susceptibility and sensitivity of machines to unbalance*
- [7] API 617, *Axial and centrifugal compressors and expander-compressors for petroleum, chemical and gas industry services*
- [8] ASME PTC 10, *Performance test code on compressors and exhausters*
- [9] FUKUSHIMA, Y. et al. Totally oil-less centrifugal compressor in oil refinery service. *Proceedings of Advancement in Bearing and Seal Technologies*, Calgary, Canada, 1994, pp. 18.1-18.36
- [10] HABERMANN, H. and BRUNET, M. The active magnetic bearing enables optimum control of machine vibrations. *ASME Paper 85-GT-221*, 1985
- [11] MATSUSHITA, O., KANEMITSU, Y., AZUMA, T. and FUKUSHIMA, Y. Vibration criteria considered from case studies of active magnetic bearing equipped rotating machines. *International Journal of Rotating Machinery*, **6**, No. 1, 2000, pp. 66-78
- [12] SHIRAKI, K. and KANKI, H. New vibration criteria for high speed/large capacity turbo machinery. *Proceedings of Eighth Turbomachinery Symposium*, 1979, pp. 59-70

Bureau of Indian Standards

BIS is a statutory institution established under the *Bureau of Indian Standards Act, 2016* to promote harmonious development of the activities of standardization, marking and quality certification of goods and attending to connected matters in the country.

Copyright

BIS has the copyright of all its publications. No part of these publications may be reproduced in any form without the prior permission in writing of BIS. This does not preclude the free use, in the course of implementing the standard, of necessary details, such as symbols and sizes, type or grade designations. Enquiries relating to copyright be addressed to the Head (Publication & Sales), BIS.

Review of Indian Standards

Amendments are issued to standards as the need arises on the basis of comments. Standards are also reviewed periodically; a standard along with amendments is reaffirmed when such review indicates that no changes are needed; if the review indicates that changes are needed, it is taken up for revision. Users of Indian Standards should ascertain that they are in possession of the latest amendments or edition by referring to the website-www.bis.gov.in or www.standardsbis.in.

This Indian Standard has been developed from Doc No.: PGD 13 (24935).

Amendments Issued Since Publication

Amend No.	Date of Issue	Text Affected

BUREAU OF INDIAN STANDARDS

Headquarters:

Manak Bhavan, 9 Bahadur Shah Zafar Marg, New Delhi 110002

Telephones: 2323 0131, 2323 3375, 2323 9402

Website: www.bis.gov.in

Regional Offices:

Central : 601/A, Konnectus Tower -1, 6th Floor,
DMRC Building, Bhavbhuti Marg, New
Delhi 110002

Telephones

{ 2323 7617

Eastern : 8th Floor, Plot No 7/7 & 7/8, CP Block, Sector V,
Salt Lake, Kolkata, West Bengal 700091

{ 2367 0012
2320 9474

Northern : Plot No. 4-A, Sector 27-B, Madhya Marg,
Chandigarh 160019

{ 265 9930

Southern : C.I.T. Campus, IV Cross Road, Taramani, Chennai 600113

{ 2254 1442
2254 1216

Western : 5th Floor/MTNL CETTM, Technology Street, Hiranandani Gardens, Powai
Mumbai 400076

{ 25700030
25702715

Branches : AHMEDABAD, BENGALURU, BHOPAL, BHUBANESHWAR, CHANDIGARH, CHENNAI, COIMBATORE, DEHRADUN, DELHI, FARIDABAD, GHAZIABAD, GUWAHATI, HARYANA (CHANDIGARH), HUBLI, HYDERABAD, JAIPUR, JAMMU, JAMSHEDPUR, KOCHI, KOLKATA, LUCKNOW, MADURAI, MUMBAI, NAGPUR, NOIDA, PARWANOO, PATNA, PUNE, RAIPUR, RAJKOT, SURAT, VIJAYAWADA.