

रीफ्रैक्टरीज़ — इम्पल्स एक्साईटेशन ऑफ़
वाइब्रेशन के द्वारा एलिंक्टेड टेम्परेचर्स में
डायनामिक यंग्स मॉड्यूलस (एमओइ)
निर्धारित करना

Refractories — Determination of
Dynamic Young's Modulus (MOE) at
Elevated Temperatures by Impulse
Excitation of Vibration

ICS 81.080

© BIS 2024
© ISO 2020



भारतीय मानक ब्यूरो
BUREAU OF INDIAN STANDARDS
मानक भवन, 9 बहादुर शाह ज़फर मार्ग, नई दिल्ली - 110002
MANAK BHAVAN, 9 BAHADUR SHAH ZAFAR MARG
NEW DELHI - 110002

www.bis.gov.in www.standardsbis.in

NATIONAL FOREWORD

This Indian Standard which is identical to ISO 22605 : 2020 'Refractories — Determination of dynamic Young's modulus (MOE) at elevated temperatures by impulse excitation of vibration' issued by the International Organization for Standardization (ISO) was adopted by the Bureau of Indian Standards on the recommendation of the Refractories Sectional Committee and approval of the Metallurgical Engineering Division Council.

The text of ISO standard has been approved as suitable for publication as in Indian Standard without deviations. Certain terminologies and conventions are, however, not identical with those used in Indian Standard. Attention is especially drawn to the following:

- a) Wherever the words 'International Standard' appear referring to this standard, it should be read as 'Indian Standard'; and
- b) Comma (,) has been used as a decimal marker while in Indian Standards the current practice is to use a point (.) as the decimal marker.

In this adopted standard, reference appears to certain International Standards for which Indian Standard also exists. The corresponding Indian Standards which are to be substituted in their place are listed below along with their degree of equivalence for the edition indicated:

<i>International Standard</i>	<i>Corresponding Indian Standard</i>	<i>Degree of Equivalence</i>
ISO 5022 Shaped refractory products — Sampling and acceptance testing	IS 1528 (Part 7) : 2010 Methods of sampling and physical tests for refractory materials: Part 7 methods of sampling and criteria for conformity (second revision)	Not Equivalent
ISO 8656-1 Refractory products — Sampling of raw materials and unshaped products — Part 1: Sampling scheme	IS 1528 (Part 7) : 2010 Methods of sampling and physical tests for refractory materials: Part 7 methods of sampling and criteria for conformity (second revision)	Not Equivalent
ISO 12680-1 Methods of test for refractory products — Part 1: Determination of dynamic Young's modulus (MOE) by impulse excitation of vibration	MTD 15 (23810) Methods of test for refractory products: Part 1 Determination of dynamic Young's modulus (MOE) by impulse excitation of vibration	Identical
ISO 16835 Refractory products — Determination of thermal expansion	IS 1528 (Part 19) : 2020/ISO 16835 : 2014 Methods of sampling and physical tests for refractory materials: Part 19 Determination of thermal expansion (first revision)	Identical
IEC 60584-1 Thermocouples — Part 1: EMF specifications and tolerances	IS 16923 (Part 1) : 2018/IEC 60584-1 : 2013 Thermocouples: Part 1 EMF specifications and tolerances (first revision)	Identical
IEC 60584-2 Thermocouples ¹⁾ — Part 2: Tolerances	IS 16923 (Part 1) : 2018/IEC 60584-1 : 2013 Thermocouples: Part 1 EMF specifications and tolerances (first revision)	Identical

¹⁾ The International Standard IEC 60584-2 : 1982 'Thermocouples — Part 2: Tolerances' has been replaced by IEC 60584-1 : 2013 'Thermocouples — Part 1: EMF specifications and tolerances' which is adopted as a Indian Standard IS 16923 (Part 1) : 2018 'Thermocouples: Part 1 EMF specifications and tolerances (first revision)' under dual numbering system.

Contents

Page

1	Scope	1
2	Normative references	1
3	Terms and definitions	1
4	Principle	3
5	Significance and use	3
6	Apparatus	4
7	Sampling	5
8	Test specimens	5
	8.1 Specimen geometry.....	5
	8.2 Specimen dimensions.....	6
	8.3 Surface finishing of specimens.....	6
9	Procedure	6
	9.1 Specimen drying.....	6
	9.2 Determination of specimen mass and dimension.....	6
	9.3 Loading of the test specimen.....	6
	9.4 Determination of the room temperature Young's modulus.....	6
	9.5 Determination of fundamental flexural resonant frequency.....	7
	9.5.1 Method A: Isothermal measurement at pre-set temperature.....	7
	9.5.2 Method B: Continuous measurement during ramping to test temperature.....	8
10	Calculations	8
11	Test report	8
	Annex A (informative) Factors affecting accuracy of determinations	10
	Annex B (informative) Calculation of Young's modulus at room temperature (according to ISO 12680-1)	11

Indian Standard

REFRACTORIES — DETERMINATION OF DYNAMIC YOUNG'S MODULUS (MOE) AT ELEVATED TEMPERATURES BY IMPULSE EXCITATION OF VIBRATION

1 Scope

This document specifies a method for determining the dynamic Young's modulus of rectangular cross-section bars and circular cross-section specimens of refractories by impulse excitation of vibration at elevated temperature. The dynamic Young's modulus is determined using the resonant frequency of the specimen in its flexural mode of vibration.

This document does not address the safety issues associated with its use. It is responsibility of the users of this standard to establish appropriate safety and health practices.

2 Normative references

The following documents are referred to in the text in such a way that some or all of their content constitutes requirements of this document. For dated references, only the edition cited applies. For undated references, the latest edition of the referenced document (including any amendments) applies.

ISO 5022, *Shaped refractory products — Sampling and acceptance testing*

ISO 8656-1, *Refractory products — Sampling of raw materials and unshaped products — Part 1: Sampling scheme*

ISO 12680-1, *Methods of test for refractory products — Part 1: Determination of dynamic Young's modulus (MOE) by impulse excitation of vibration*

ISO 16835, *Refractory products — Determination of thermal expansion*

IEC 60584-1, *Thermocouples — Part 1: EMF specifications and tolerances*

IEC 60584-2, *Thermocouples — Part 2: Tolerances*

3 Terms and definitions

For the purposes of this document, the following terms and definitions apply.

ISO and IEC maintain terminological databases for use in standardization at the following addresses:

- ISO Online browsing platform: available at <https://www.iso.org/obp>
- IEC Electropedia: available at <http://www.electropedia.org/>

3.1

modulus of elasticity

MOE

ratio of stress to strain below the *proportional limit* (3.2)

3.2

proportional limit

greatest stress which a material is capable of sustaining without deviation from proportionality of stress to strain (Hooke's Law)

3.3 homogeneous

uniform composition, density and texture

Note 1 to entry: A result of homogeneity is that any smaller specimen taken from the original is representative of the whole. In refractory practice, as long as the geometrical dimensions of the specimen are large with respect to the size of individual grains, crystals, components, pores and microcracks, the body can be considered homogeneous.

3.4 isotropic

condition of a specimen such that the values of the elastic properties are the same in all directions in the specimen

3.5 resonant frequency

natural frequencies of vibration of a body driven into *flexural vibration* (3.6)

Note 1 to entry: Resonant frequencies are determined by the elastic modulus, mass and dimensions of the specimen. The lowest resonant frequency in a vibrational mode is the fundamental resonant.

3.6 flexural vibrations

displacements in a *slender bar or rod* (3.11) in the plane normal to its length

3.7 nodes

location on a *slender bar or rod* (3.11) in resonance having a constant zero displacement

Note 1 to entry: For the fundamental flexural resonance of such a rod or bar, the nodes are located at $0,224L$ from each end, where L is the length of the specimen.

3.8 anti-nodes

locations, generally two or more, of local maximum displacement in an unconstrained *slender bar or rod* (3.11) in resonance

Note 1 to entry: For the fundamental flexural resonance, the anti-nodes are located at the two ends and the centre of the specimen.

3.9 out-of-plane flexure

flexural mode for rectangular parallelepiped geometry specimens in which the direction of the displacement is perpendicular to the major plane of the specimen

3.10 in-plane flexure

flexural mode for rectangular parallelepiped geometry specimens in which the direction of the displacement is in the major plane of the specimen

3.11 slender bar slender rod

slender bar whose ratio of length to width is at least 3 and the ratio of length to thickness is at least 5, slender rod whose ratio of length to diameter is at least 5

Note 1 to entry: This applies to dynamic property testing.

4 Principle

A test specimen of suitable geometry is heated up to the test temperature and allowed to stabilize at this temperature. It is then excited mechanically with a single elastic strike by an adequate impulse tool (Method A).

Alternatively, the test specimen is heated up (resp. cooled down) at a low heating rate (resp. cooling rate) to the test temperature, excited mechanically with a single elastic strike by an adequate impulse tool at regular intervals and the fundamental resonant frequency values are determined (Method B).

A vibration signal detector (e.g. non-contacting microphone or laser vibrometer) senses the mechanical vibrations in the specimen resulting from the excitation and transforms the vibrations into electrical signals. Specimen supports, impulse locations and signal pick-up points are selected to induce and measure a specific mode of transient vibrations, i.e. the flexural mode. The signals are analysed and a signal analyser that provides data about the frequency and/or the period of the specimen's vibration determines the fundamental resonant frequency. The appropriate fundamental resonant frequency, dimensions and mass of the specimen are then used to calculate the dynamic Young's modulus at this test temperature.

5 Significance and use

This test method may be used for refractory characterization, development and quality control purposes.

This test method is appropriate for determining the modulus of elasticity of refractory bodies that are homogeneous in nature.

This method addresses the determination of the dynamic moduli of elasticity of slender rectangular bars and cylindrical rods.

This test method is non-destructive in use, so it may be used on specimens prepared for other tests. The specimens are subjected to only minute strains; hence the moduli are measured at or near the origin of the stress-strain curve with a minimum possibility of specimen fracture.

The test provides options for variations in test specimen sizes and procedure to accommodate most refractory compositions and textures.

The impulse excitation test method utilizes an impact tool (hammer) and simple supports for the test specimen.

This test method is not suitable for specimens with major cracks or voids.

This test method is limited to determining moduli of specimens with regular geometries, such as rectangular parallelepipeds and cylinders, for which analytical equations are available to relate geometry, mass and modulus to the resonant vibration frequency.

The analytical equations assume parallel or concentric dimensions for the geometry of the specimens. Deviations in the dimensions of the specimens will introduce errors in the calculations and in the results of the test.

Uneven or excessively rough surfaces of as-formed specimens can have a significant effect on the accuracy of the determination. The dynamic modulus value is inversely proportional to the cube of the thickness, so the thickness variation is significant.

This test method assumes that the specimen is vibrating freely with no significant or impediment. Specimen supports should be designed and located so the specimen can vibrate freely in the proper mode.

6 Apparatus

The equipment includes the furnace, the pulse excitation, measure device and the specimen support device. The structure principle of the equipment is shown in [Figure 1](#).

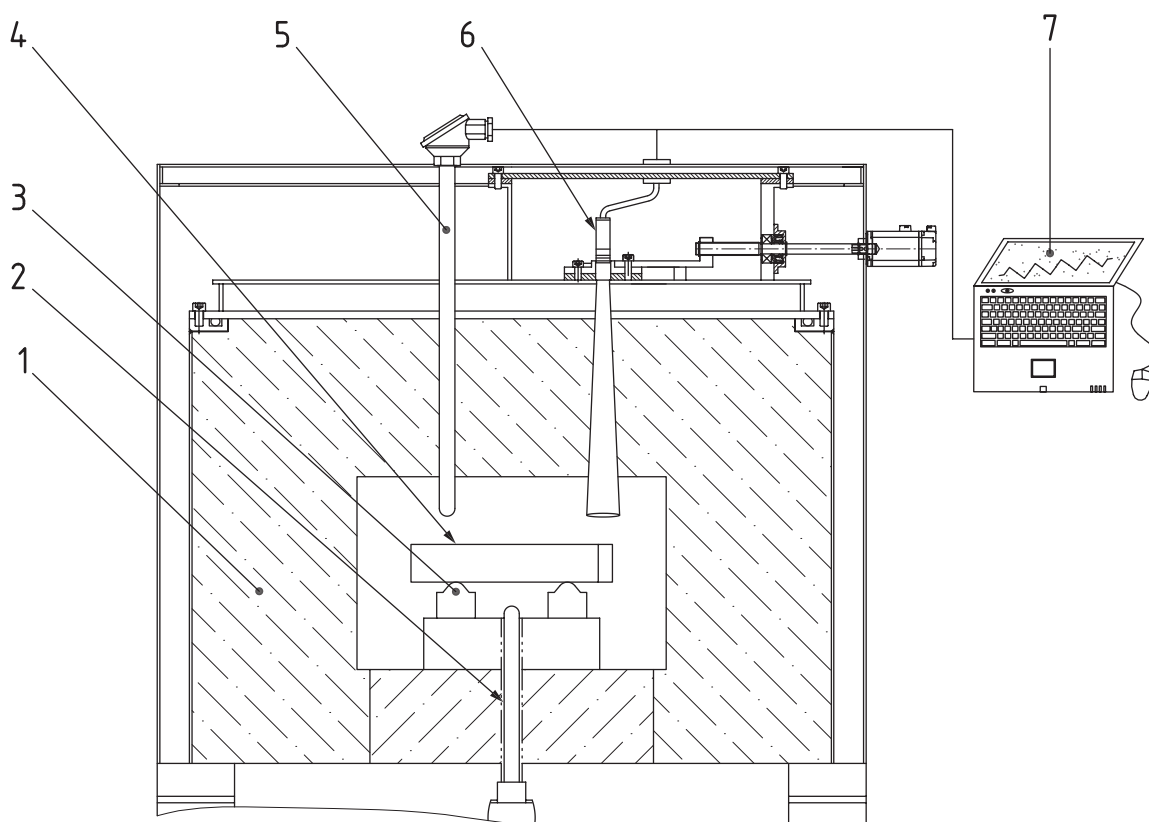

Key

- 1 lining
- 2 impulse excitation tool
- 3 specimen support device
- 4 specimen
- 5 thermocouple
- 6 vibration signal detector
- 7 signal analyser

Figure 1 — Structure principle of the equipment

6.1 Furnace

An electrical furnace can be used, capable of raising the temperature of the specimen to the test temperature at the specified rate (see [9.5.2](#)) and shall be so designed that at the moment of test the temperature distribution in the test pieces is uniform within ± 5 °C.

The atmosphere in the furnace shall be air, inert gas or some other specified gas, at atmospheric pressure, as agreed between the parties concerned in the test.

6.2 Impulse excitation measuring device

Including impulse excitation tool, vibration signal detector and signal analyser (see [Figure 1](#)). Used for excitation, detection, analysis and recording the natural frequencies of the specimens.

6.2.1 The impulse excitation tool and the specimen should not occur any chemical reaction or deformation under the test temperature. The force of the impulse excitation tool should be adjustable to be able to make the specimen to produce the appropriate vibration amplitude but cannot cause physical damage to the specimen or cause the specimen to move.

6.2.2 Including vibration signal detector set-up suitable for high temperature measurements, the measuring range is at least 50 Hz to 20 kHz.

The frequency response of the vibration signal detector across the frequency range of interest shall have a bandwidth of at least 10 % of the maximum measured frequency before -3 dB power loss occurs.

NOTE The vibration signal detectors are commonly acoustic microphones. However laser, magnetic or capacitance methods to measure the vibration can also be used.

6.2.3 The frequency analysed by the signal analyser shall have an accuracy of 0,1 % or lower.

6.3 Specimen support device

The specimen is supported, preferably by lightweight materials, on sharp knife edges or cylindrical surfaces. Alternatively, a wire suspension system is used. The specimen should be positioned horizontally in the furnace.

The specimen support device should ensure that the specimen is free vibrating in the flexural vibration mode after the impulse excitation. At the test temperature, there should not be any chemical reaction or deformation. The supports should be examined periodically.

The supports are located at the nodes of the flexural vibration mode, which is $0,224L$ from the ends of the specimen.

6.4 Thermocouple, meeting the requirements of IEC 60584-1 and IEC 60584-2.

The thermocouple to measure the specimen temperature shall be positioned as close as possible to the specimen.

6.5 Vernier caliper, division values 0,02 mm.

6.6 Drying box, can control the temperature in (110 ± 5) °C.

6.7 Electronic balance, division values 0,01 g.

7 Sampling

The number of specimens to be tested shall be determined in accordance with ISO 5022 for shaped products or ISO 8656-1 for unshaped products or using a sampling plan agreed upon between the interested parties.

8 Test specimens

8.1 Specimen geometry

The specimens shall be simple beams or slender rods, either rectangular or circular in cross section. See [3.11](#).

8.2 Specimen dimensions

Resonant frequencies of specimens are a function of the specimens' dimensions as well as their masses and moduli of elasticity. Using an estimated modulus, specimen size shall be chosen so that the expected resonant frequencies fall within the frequency response range of the transducers and the signal analysis system to be used. The smallest dimension of the specimen shall be at least 4 times the largest grain or particle size.

8.3 Surface finishing of specimens

All surfaces of a rectangular specimen shall be flat and sufficiently parallel so that opposite faces across the length, width and thickness dimensions are parallel to within 1 %. The diameter of a cylindrical specimen shall vary by no more than 1 %.

9 Procedure

9.1 Specimen drying

The test pieces shall be dried at 110 ± 5 °C to constant mass.

9.2 Determination of specimen mass and dimension

Determine the mass of specimens to a precision of 0,2 % and measure the length, width and thickness of the specimens to a precision of 0,2 %.

9.3 Loading of the test specimen

Place the specimen on supports located at the fundamental nodal points, i.e. $0,224L$ from each end (see [Figure 2](#)). Determine the direction of maximum sensitivity for the vibration signal detector. Orient the vibration signal detector in the direction that will utilize this maximum sensitivity to detect the desired vibrations.

a) Direct-contact vibration signal detector

Place the direct-contact vibration signal detector in contact with the test specimen to pick up the desired vibration. If the vibration signal detector is placed at an antinode (a location of maximum displacement), its mass may load the test specimen and modify the natural vibration. The vibration signal detector should preferably be placed only as far from the nodal points as necessary to obtain a reading. This location will minimize the damping effect of the contacting vibration signal detector. The vibration signal detector contact force should be sufficient to obtain a good response, yet only mainly interfere with the free vibration of the specimen.

b) Non-contact vibration signal detector

Place the non-contact vibration signal detector over an antinode point, close enough to the test specimen to pick up the desired vibration but not so close as to interfere with the free vibration of the test specimen.

9.4 Determination of the room temperature Young's modulus

Adjust the impulse excitation force, test and record the fundamental resonance frequency in flexural mode of the specimen at room temperature. Calculate the corresponding Young's modulus according to [Annex B](#).

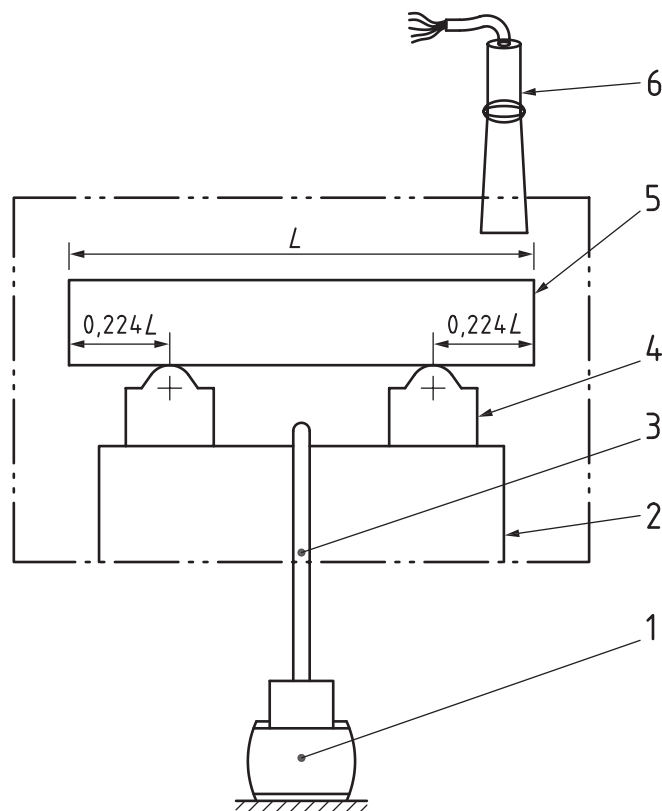

Key

- 1 impulse excitation tool
- 2 high temperature platform
- 3 impacter
- 4 specimen support
- 5 specimen
- 6 vibration signal detector

Figure 2 — Schematic of sample placement

9.5 Determination of fundamental flexural resonant frequency

9.5.1 Method A: Isothermal measurement at pre-set temperature

Heat the test specimen to the test temperature using a convenient heating rate. When the test temperature is reached, maintain the test temperature for a period in order to stabilize and homogenize the temperature of the test specimen. After the holding period, strike the test specimen lightly at one of the anti-node positions of the specimen (see [Figure 2](#)). Record the reading from the electronic frequency analyser system. Repeat this striking and reading sequence until five consecutive readings lie with 1 % of each other. Use the mean average of these five readings to determine the fundamental resonant frequency of the test specimen in flexure.

The holding period is about 15 to 30 minutes for normal test pieces of fired bricks. For unfired bricks or unshaped refractories, a pre-treatment or soaking time and temperature shall be agreed between the interested parties.

NOTE 1 The test temperature is chosen by agreement between parties.

9.5.2 Method B: Continuous measurement during ramping to test temperature

Heat the test specimen at a low heating rate of typically 1 °C/min or 2 °C/min up to the maximum test temperature.

NOTE 1 The maximum test temperature is chosen by agreement between parties.

Strike the test specimen lightly at one of the antinode positions of the specimen at regular intervals.

NOTE 2 The interval can be defined either in terms of time (e.g. every 2 min) or in terms of temperature (e.g. every 2 °C).

Record the reading of the fundamental resonant frequency of the test specimen in flexure at this intermediate temperature from the electronic frequency analyser system.

NOTE 3 Similar continuous measurement can be performed while cooling the test specimen back to room temperature, provided that the cooling rate is also kept low (typically 1 or 2 °C/min).

10 Calculations

Young's modulus at elevated temperature, E_T , in Pascal, corrected for the thermal expansion effects, using [Formula \(1\)](#):

$$E_T = E_{RT} \left(\frac{f_T}{f_{RT}} \right)^2 \left[\frac{1}{1 + \alpha (T_T - T_{RT})} \right] \quad (1)$$

where

E_T Young's modulus at elevated temperature (T_T), Pa;

E_{RT} Young's modulus at room temperature (T_{RT}), Pa;

f_T the resonant frequency of specimen at elevated temperature, Hz;

f_{RT} the resonant frequency of specimen at room temperature, Hz;

α the average linear thermal expansion coefficient of specimen from room temperature to elevated temperature, expressed as change in length per unit length per degree Celsius, °C⁻¹;

T_T elevated temperature, °C;

T_{RT} room temperature, °C.

NOTE 1 The average linear thermal expansion coefficient value (α) to be used is ideally determined according to ISO 16835, using an adequate test specimen of the same refractory product; alternatively known values from the literature for the same type of refractory products can be used.

NOTE 2 Omission of the correction of the thermal expansion can induce, at high temperature (i.e. >1 000 °C), a maximum underestimation of the Young's modulus in the range of 1 % to 2 %.

NOTE 3 The factors affecting accuracy of determinations are shown in [Annex A](#).

11 Test report

The test report shall include following information:

- a) all information necessary for identification of the sample tested;
- b) a reference to this document (ISO 22605:2020);

- c) details of the method used, including:
 - 1) the number of items tested;
 - 2) the size, shape and heat treatment conditions of the test specimens;
 - 3) chosen method, isothermal or continuous;
 - 4) the Poisson ratio used in the calculations and how it was obtained;
 - 5) the average linear thermal expansion value used in the calculations and how it was obtained;
- d) test results:
 - 1) for Method A: the results of the test, including the results of the individual determinations and their mean calculated as specified in [Clause 10](#), including numerical values obtained for the measured fundamental resonant frequencies and the calculated dynamic Young's moduli of elasticity;
 - 2) for Method B: a curve of the evolution with temperature of the dynamic Young's moduli of elasticity calculated according to [Clause 10](#);
- e) the name of the test establishment;
- f) any deviations from the procedure specified;
- g) any unusual features (anomalies) observed during the test;
- h) the date and time the test was begun and terminated.

Annex A (informative)

Factors affecting accuracy of determinations

A propagation of errors analysis of the equations for calculating E , using the tolerances for dimensions, mass and frequency measurements noted in this method, has shown that a 1 % error in the measurement of the key variables produces a range of errors in the calculated modulus of elasticity, which is based on the variable's exponent in the equation used to calculate the modulus. [Table A.1](#) shows error in the calculated modulus of elasticity resulting from errors in the different key measured variables.

Table A.1 — Effect of measured variables errors on calculated modulus of elasticity

Variable	Measurement error/%	Variable exponent in modulus equation	Calculation modulus of elasticity error/%
Frequency, f	1	F^2	2
Length, L	1	L^3	3
Mass, m	1	m	1
Width, b	1	b^{-1}	1
Thickness, t	1	t^{-3}	3
Diameter, D	1	D^{-4}	4

Annex B (informative)

Calculation of Young's modulus at room temperature (according to ISO 12680-1)

B.1 Calculations

B.1.1 Rectangular specimens. Calculate the Young's modulus, E , in pascals, for a rectangular specimen using [Formula \(B.1\)](#):

$$E = 0,9465 \left(\frac{mf_1^2}{b} \right) \left(\frac{L^3}{t^3} \right) T_1 \quad (\text{B.1})$$

where

m is the mass of the test specimen, in grams;

b is the width of the test specimen, in millimetres;

L is the length of the test specimen, in millimetres;

t is the thickness of the test specimen, in millimetres;

f_1 is the fundamental resonant frequency of the test specimen in flexure, in hertz;

T_1 is the correction factor for the fundamental flexural mode to account for the finite thickness of the bar, Poisson's ratio, etc. calculated from [Formula \(B.2\)](#):

$$T_1 = 1 + 6,585 \left(1 + 0,0752\mu + 0,8109\mu^2 \right) \left(\frac{t}{L} \right)^2 - 0,868 \left(\frac{t}{L} \right)^4 - J \quad (\text{B.2})$$

where

$$J = \frac{\left[8,340 \left(1 + 0,2023\mu + 2,173\mu^2 \right) \left(\frac{t}{L} \right)^4 \right]}{\left[1 + 6,338 \left(1 + 0,1408\mu + 1,536\mu^2 \right) \left(\frac{t}{L} \right)^2 \right]} \quad (\text{B.3})$$

and μ is Poisson's ratio

B.1.2 If L/t is equal to or greater than 20, T_1 can be simplified to

$$T = 1 + 6,585 \left(\frac{t}{L} \right)^2 \quad (\text{B.4})$$

and E can be calculated directly.

B.1.3 If L/t is less than 20 and Poisson's ratio is known, T_1 can be calculated from [Formula \(B.2\)](#) and then used to calculate Young's modulus, E .

NOTE The frequency (f_1) is the flexural frequency.

B.1.4 Young's modulus can be calculated from the flexural resonant frequency alone by assuming a value for Poisson's ratio. Unless the value of the Poisson's ratio is known or measured by other means, 0,15 shall be used as it is considered an appropriate value for most refractories.

B.2 Cylindrical rod specimens

B.2.1 Calculate Young's modulus, E , in pascals, for a cylindrical rod specimen using [Formula \(B.5\)](#):

$$E = 1,6067 \left(\frac{L^3}{D^4} \right) (mf_1^2) T_1 \quad (\text{B.5})$$

where

m is the mass of the test specimen, in grams;

L is the length of the test specimen, in millimetres;

D is the diameter of the test specimen, in millimetres;

f_1 is the fundamental resonant frequency of the test specimen in flexure, in hertz;

T_1 is the correction factor for the fundamental flexural mode to account for the finite thickness of the specimen, Poisson's ratio, etc. calculated from [Formula \(B.6\)](#):

$$T_1 = 1 + 4,939 \left(1 + 0,0752\mu + 0,8109\mu^2 \right) \left(\frac{D}{L} \right)^2 - 0,4883 \left(\frac{D}{L} \right)^4 - J \quad (\text{B.6})$$

where

$$J = \frac{\left[4,691 \left(1 + 0,2023\mu + 2,173\mu^2 \right) \left(\frac{D}{L} \right)^4 \right]}{\left[1 + 4,754 \left(1 + 0,1408\mu + 1,536\mu^2 \right) \left(\frac{D}{L} \right)^2 \right]} \quad (\text{B.7})$$

and μ is Poisson's ratio.

B.2.2 If L/D is equal to or greater than 20, then T_1 can be simplified to:

$$T_1 = \left[1 + 4,939 \left(\frac{D}{L} \right)^2 \right] \quad (\text{B.8})$$

and E can be calculated directly.

B.2.3 If L/D is less than 20 and Poisson's ratio is known, T_1 can be calculated from [Formula \(B.6\)](#) and then used to calculate Young's modulus, E .

NOTE The frequency (f_1) is the flexural frequency.

B.3 Alternative calculations

Young's modulus can be calculated from the flexural resonant frequency alone by assuming a value for Poisson's ratio. Unless the value of the Poisson's ratio is known or measured by other means, 0,15 is considered an appropriate value for most refractories.

(Continued from second cover)

In reporting the result of a test or analysis made in accordance with this standard, is to be rounded off, it shall be done in accordance with IS 2 : 2022 'Rules for rounding off numerical values (*second revision*)'. The number of significant places retained in the rounded off value should be the same as that of the specified value in this standard.

Bureau of Indian Standards

BIS is a statutory institution established under the *Bureau of Indian Standards Act, 2016* to promote harmonious development of the activities of standardization, marking and quality certification of goods and attending to connected matters in the country.

Copyright

BIS has the copyright of all its publications. No part of these publications may be reproduced in any form without the prior permission in writing of BIS. This does not preclude the free use, in the course of implementing the standard, of necessary details, such as symbols and sizes, type or grade designations. Enquiries relating to copyright be addressed to the Head (Publication & Sales), BIS.

Review of Indian Standards

Amendments are issued to standards as the need arises on the basis of comments. Standards are also reviewed periodically; a standard along with amendments is reaffirmed when such review indicates that no changes are needed; if the review indicates that changes are needed, it is taken up for revision. Users of Indian Standards should ascertain that they are in possession of the latest amendments or edition by referring to the website-www.bis.gov.in or www.standardsbis.in.

This Indian Standard has been developed from Doc No.: MTD 15 (23822).

Amendments Issued Since Publication

Amend No.	Date of Issue	Text Affected

BUREAU OF INDIAN STANDARDS

Headquarters:

Manak Bhavan, 9 Bahadur Shah Zafar Marg, New Delhi 110002

Telephones: 2323 0131, 2323 3375, 2323 9402

Website: www.bis.gov.in

Regional Offices:

Central : 601/A, Konnectus Tower -1, 6th Floor,
DMRC Building, Bhavbhuti Marg, New
Delhi 110002

Telephones

{ 2323 7617

Eastern : 8th Floor, Plot No 7/7 & 7/8, CP Block, Sector V,
Salt Lake, Kolkata, West Bengal 700091

{ 2367 0012
2320 9474

Northern : Plot No. 4-A, Sector 27-B, Madhya Marg,
Chandigarh 160019

{ 265 9930

Southern : C.I.T. Campus, IV Cross Road, Taramani, Chennai 600113

{ 2254 1442
2254 1216

Western : Manakalya, 4th Floor, NTH Complex (W Sector), F-10, MIDC, Andheri
(East), Mumbai 400093

{ 283 25838

Branches : AHMEDABAD, BENGALURU, BHOPAL, BHUBANESHWAR, CHANDIGARH, CHENNAI, COIMBATORE, DEHRADUN, DELHI, FARIDABAD, GHAZIABAD, GUWAHATI, HARYNA, HUBLI, HYDERABAD, JAIPUR, JAMMU & KASHMIR, JAMSHEDPUR, KOCHI, KOLKATA, LUCKNOW, MADURAI, MUMBAI, NAGPUR, NOIDA, PARWANOO, PATNA, PUNE, RAIPUR, RAJKOT, SURAT, VIJAYAWADA.