

भारतीय मानक
Indian Standard

IS 16052 (Part 7) : 2024
ISO 13765-7 : 2021

(Superseding IS 13185 : 1991)

अग्निसह मोर्टारस

भाग 7 तापन पर आयाम में स्थायी परिवर्तन ज्ञात
करना

Refractory Mortars

Part 7 Determination of Permanent
Change in Dimensions on Heating

ICS 81.080

© BIS 2024

© ISO 2021



भारतीय मानक ब्यूरो

BUREAU OF INDIAN STANDARDS

मानक भवन, 9 बहादुर शाह ज़फ़र मार्ग, नई दिल्ली - 110002

MANAK BHAVAN, 9 BAHADUR SHAH ZAFAR MARG

NEW DELHI - 110002

www.bis.gov.in

www.standardsbis.in

October 2024

Price Group 6

NATIONAL FOREWORD

This Indian Standard (Part 7) which is identical to ISO 13765-7 : 2021 'Refractory mortars — Part 7: Determination of permanent change in dimensions on heating' issued by the International Organization for Standardization (ISO), was adopted by the Bureau of Indian Standards on the recommendation of the Refractories Sectional Committee and approval of the Metallurgical Engineering Division Council.

This Indian Standard (Part 7) was adopted after thoroughly reviewing the already existing indigenous Indian Standards on drying shrinkage measurement namely IS 13185 : 1991 'Method of test for determination of drying shrinkage of refractory mortars' and on testing of air-setting mortars namely IS 11452 : 1985 'Methods of testing air-setting refractory mortars' vis-a-vis the corresponding ISO standard namely ISO 13765-7 : 2021 and other six parts of the aforementioned ISO standard which were already adopted as Indian Standards under dual numbering system mentioned below.

During the review, it was observed that the indigenous Indian Standard, namely IS 13185 : 1991, covers only the drying shrinkage of refractory mortars as compared to ISO 13765-7 : 2021 which covers determination of permanent change in dimensions on heating (drying and/or firing) of refractory mortars. Hence, this Indian Standard (Part 7), over and above prescribing the test method for determination of firing shrinkage, also covers the determination of drying shrinkage as given in IS 13185 : 1991.

Further, the methods of testing air-setting refractory mortars were earlier also covered in IS 11452 : 1985 which specified the test methods of all types of air-setting mortars available in premixed state (dry/wet) or as two components (powder and liquid binder supplied separately). The test methods described in IS 11452 : 1985 were sieve analysis, chemical analysis, bond strength, refractoriness and, drying and firing shrinkage. However, the standard lacked consistency measurement methods which is the measure of the viscosity of the material in its ready-to-use state and is considered a vital requirements for any type of mortar and is already covered in IS 16052 (Part 1) : 2013/ISO 13765-1 : 2004 Refractory mortars: Part 1 Determination of consistency using the penetrating cone method. The Sectional Committee while reviewing felt necessary to withdraw the Indian standard IS 11452 : 1985 as the test methods for determination of bond strength/flexural bond strength, sieve analysis, drying and firing shrinkage were already covered in IS 16052 (Part 4) : 2013/ISO 13765-4 : 2004 'Refractory mortars: Part 4 Determination of flexural bonding strength', IS 16052 (Part 5) : 2013/ISO 13765-5 : 2004 'Refractory mortars: Part 5 Determination of grain size distribution (sieve analysis)' and this part of Indian Standard (Part 7) respectively.

Hence in view of aforementioned paragraphs, this current part of Indian Standard, completely supersedes IS 13185 : 1991, and partially supersedes the test methods of drying and firing shrinkage covered in IS 11452 : 1985.

NOTE — The IS 11452 : 1985 will be withdrawn and superseded by IS 16052 (Part 4), IS 16052 (Part 5), IS 16052 (Part 7) for determination of bond strength, sieve analysis and, drying and firing shrinkage respectively.

This standard is published in several parts. Other parts in this series are:

Part 1 Determination of consistency using the penetrating cone method

[\(Continued on third cover\)](#)

Contents

Page

1	Scope	1
2	Normative references	1
3	Terms and definitions	1
4	Principle	1
5	Apparatus	1
6	Test preparation	2
	6.1 Sampling	2
	6.2 Preparation of the refractory bricks	2
7	Procedure	3
	7.1 Preparation of the test specimens	3
	7.2 Measurement of test specimens	4
	7.3 Drying the test specimens	4
	7.4 Firing the test specimens	4
	7.5 Measurement of test specimens after heating (drying or firing)	5
8	Calculations	5
	8.1 The permanent change in dimensions on drying	5
	8.2 The permanent change in dimensions on firing	5
	8.3 The permanent change in dimensions on heating	5
9	Precision	6
	9.1 Interlaboratory tests	6
	9.2 Repeatability	6
	9.3 Reproducibility	6
10	Reporting	6
	Annex A (informative) Results of interlaboratory tests	7

Indian Standard
REFRACTORY MORTARS
PART 7 DETERMINATION OF PERMANENT CHANGE IN DIMENSIONS
ON HEATING

1 Scope

This document describes the method for determining the permanent change in dimensions on heating (drying and/or firing) of refractory mortars.

2 Normative references

The following documents are referred to in the text in such a way that some or all of their content constitutes requirements of this document. For dated references, only the edition cited applies. For undated references, the latest edition of the referenced document (including any amendments) applies.

ISO 8656-1, *Refractory products — Sampling of raw materials and unshaped products — Part 1: Sampling scheme*

ISO 13765-1, *Refractory mortars — Part 1: Determination of consistency using the penetrating cone method*

ISO 13765-2, *Refractory mortars — Part 2: Determination of consistency using the reciprocating flow table method*

ISO 13765-3, *Refractory mortars — Part 3: Determination of joint stability*

3 Terms and definitions

No terms and definitions are listed in this document.

ISO and IEC maintain terminology databases for use in standardization at the following addresses:

- ISO Online browsing platform: available at <https://www.iso.org/obp>
- IEC Electropedia: available at <https://www.electropedia.org/>

4 Principle

A mortar sample is heated and the dimensional change after heating is determined. Place the test specimens of refractory mortars, whose length between two marks has been determined, in a drying oven or furnace. Heat (drying and/or firing) to a specified temperature for a specified time and then cool to room temperature. Measure the length between two marks again. Calculate the permanent change in dimensions on heating.

5 Apparatus

5.1 Mixer, as specified in ISO 13765-1 or ISO 13765-2.

5.2 Balance, with a maximum weighing capacity of 10 kg and capable of weighing to the nearest 1 g.

5.3 **Cutting device**, a trowel.

5.4 **Nylon filter cloth**, single layer nylon mesh filter cloth, 80 mesh~200 mesh.

5.5 **Electrical drying oven**, fitted with a temperature controller and capable of operating at $110\text{ }^{\circ}\text{C} \pm 5\text{ }^{\circ}\text{C}$.

5.6 **Furnace**, the maximum temperature for the furnace should not lower than $1\ 600\text{ }^{\circ}\text{C}$. And the temperature difference shall not exceed $\pm 10\text{ }^{\circ}\text{C}$ in the furnace.

5.7 **Refractory powders**, the particle size shall less than 0,1 mm.

5.8 **Refractory bricks**, $(114 \pm 1)\text{ mm} \times (65 \pm 1)\text{ mm} \times (32 \pm 1)\text{ mm}$, which should be the same as the bricks used in the actual construction of refractory mortars.

5.9 **Length determining device**, capable of measuring to the nearest 0,05 mm.

5.10 **Rectangular frame**, 2 mm thick, with an inner length of 100_0^{+2} mm , width of 50_0^{+2} mm .

6 Test preparation

6.1 Sampling

For dry mortar, sample the mortar in accordance with ISO 8656-1 or as agreed between parties. Reduce the sample to 5 kg by quartering or with a riffle sampler.

For ready-mixed mortars, sample the mortar after mixing thoroughly. It is important that any supernatant liquid not be discarded. Ensure that a representative sample of the wet mixture is obtained.

6.2 Preparation of the refractory bricks

The size of the test specimens and the refractory bricks recommended to use is shown in [Table 1](#). The initial distance between two marks referred in [Table 1](#) is the spacing of the two marks on each diagonal of the rectangular test specimens.

At least six refractory bricks which are similar to the ones to be used in service are required. These are used for making three test specimens. Each refractory mortar test specimen is formed by two refractory bricks. The surfaces of refractory bricks to be bonded shall be clean and have no visible craters, open cracks, fins, protrusions and indentations in the surface. The bricks used in the test shall be compatible with the mortar being tested. Before testing, place the bricks in the drying oven, raise the temperature to $110\text{ }^{\circ}\text{C} \pm 5\text{ }^{\circ}\text{C}$ and hold for at least 2 h or until constant weight is achieved. Then cool to room temperature naturally.

Table 1 — Size of the test specimens and the refractory bricks

Test specimen size $l \times b$ mm	Initial distance between two marks l_0 mm	Refractory brick size recommended $l \times b \times t$ mm
$(100_0^{+2}) \times (50_0^{+2})$	90~100	$(114 \pm 1) \times (65 \pm 1) \times (32 \pm 1)$

7 Procedure

7.1 Preparation of the test specimens

7.1.1 For dry mortars, sample 2 kg using the balance and mix with water (or a specified mixing liquid) in accordance with ISO 13765-1 or ISO 13765-2 to attain the desired consistency. Determine the consistency in accordance with ISO 13765-1 and ISO 13765-2 and allow to rest for 30 min or in accordance with the manufacturer's instructions.

For ready-mixed mortars, sample 2,5 kg after mixing thoroughly.

After determining the consistency, carry out the procedures described in [7.1.2](#).

7.1.2 Take a pair of dried refractory bricks and lay nylon filter cloth on both of the uncut faces for bonding. Take out one brick and put a 2 mm thick rectangular frame with an inner length of 100_0^{+2} mm, width of 50_0^{+2} mm on the nylon filter cloth, which is used to ensure the 2 mm~4 mm thick mortar joint, then apply a layer of the well-mixed mortar to the nylon filter cloth. Place the other refractory brick with the nylon filter cloth on the mortars as shown in [Figure 1](#). Press the top brick and move it laterally at the same time according to ISO 13765-3.

The faces of each brick shall be parallel to each other within a tolerance of 1mm. Force out the excess mortar to form a joint of 2 mm~4 mm thick, unless otherwise agreed.

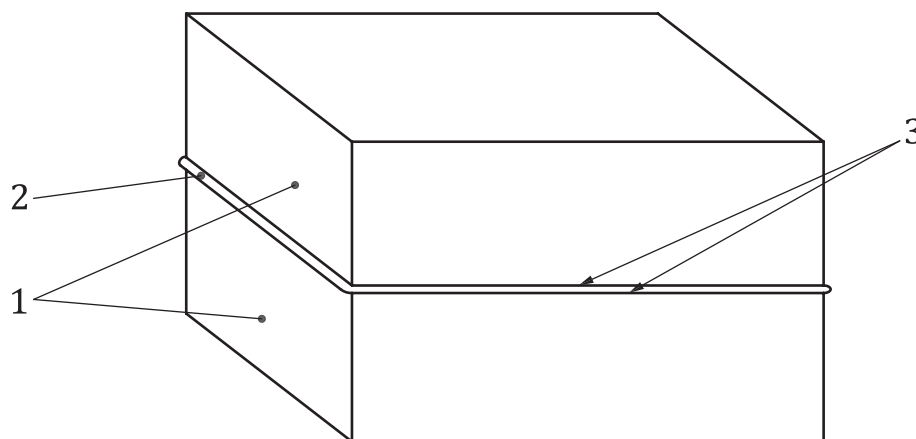

Key

- 1 brick
- 2 mortar
- 3 nylon filter cloth

Figure 1 — Placement of bricks

7.1.3 Leave the specimen at room temperature for $4 \text{ h} \pm 0,5 \text{ h}$ to become stable (according to ISO 13765-3), remove the top refractory brick and peel off the top nylon filter cloth on the mortar samples. Sprinkle a layer of dry, fine refractory powders ($\leq 0,1 \text{ mm}$), which does not react with the refractory mortars and bricks when heating, on the exposed surface, and place the refractory brick on the mortars again. Reverse the two refractory bricks and mortars as a whole and remove the top refractory brick and peel off the nylon filter cloth on the mortars just like the former step.

Do not break the mortar layer when peeling off the nylon filter cloth. Clearly visible bubbles and cavity are not permitted. Otherwise the specimens should be prepared again.

7.1.4 Separate the refractory mortar from the rectangular frame. Remove the rectangular frame and remove excess mortar (The mortar sample is stationary relative to the firebrick).

Repeat the above operations, using the six refractory bricks to make three specimens.

7.2 Measurement of test specimens

Mark 2 points on one diagonal of the mortar samples in the range of 90 mm~100 mm. Record the actual distance, mark as l_0 . Repeat the above operations on the other diagonal. As shown in [Figure 2](#).

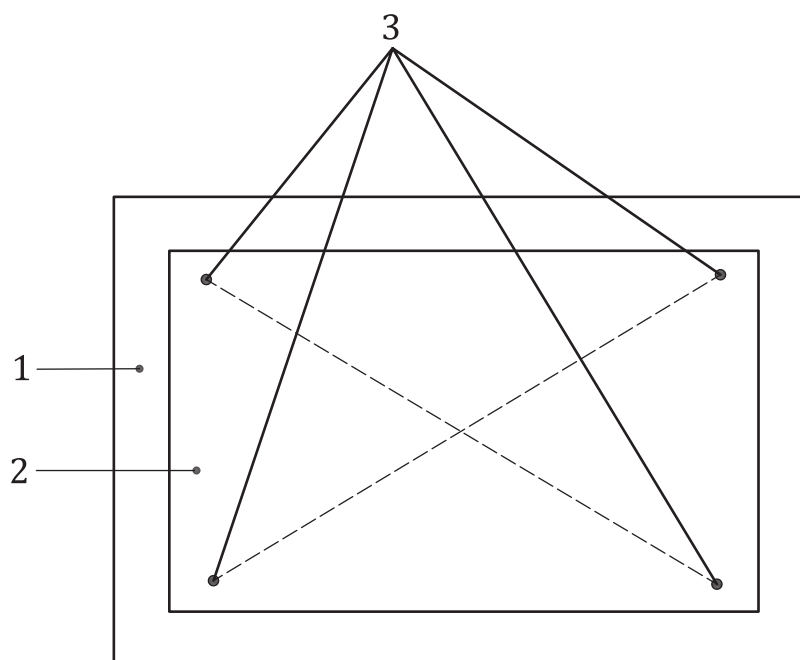

Key

- 1 brick
- 2 mortar specimen
- 3 marks

Figure 2 — Test specimen

7.3 Drying the test specimens

Air dry the test specimens and bricks naturally at room temperature for $24 \text{ h} \pm 1 \text{ h}$, and then carefully place the air-dried specimens and bricks in the drying oven, raise the temperature to $65 \text{ }^\circ\text{C} \pm 5 \text{ }^\circ\text{C}$ for $4 \text{ h} \pm 0,5 \text{ h}$. Then raise the temperature to $110 \text{ }^\circ\text{C} \pm 5 \text{ }^\circ\text{C}$ and hold for $24 \text{ h} \pm 1 \text{ h}$.

7.4 Firing the test specimens

Place the dried specimens and bricks in the soaking zone of the furnace. The distance between the specimens themselves shall not be less than 10 mm. The distance between the specimens and the heating element shall not be less than 20 mm.

When heating, maintain an oxidizing atmosphere in the furnace. Use the following heating rate:

- Normally $5 \text{ }^\circ\text{C}/\text{min}$,
- Silica mortar $3 \text{ }^\circ\text{C}/\text{min}$.

When the specified temperature (The specified temperature varies from the type of mortars and shall be negotiated by both parties) is reached, hold for $3 \text{ h} \pm 0,5 \text{ h}$ ($5 \text{ h} \pm 0,5 \text{ h}$ for silica mortar), over which the fluctuations of the temperature shall not exceed $\pm 10 \text{ }^\circ\text{C}$.

After the holding period, cool the specimens in the furnace to room temperature naturally.

7.5 Measurement of test specimens after heating (drying or firing)

For each brick measure the distance (with an accuracy of 0,05 mm) between marks of both sets of two, marks l_1 after drying and l_2 after firing.

8 Calculations

Calculate the permanent change in dimensions for each of the two diagonals, in percentage. Report the permanent change in dimensions on heating of each test specimen as the mean value of the two results.

8.1 The permanent change in dimensions on drying

The permanent change in dimensions on drying, L_d , using [Formula \(1\)](#):

$$L_d = \frac{l_1 - l_0}{l_0} \times 100 \quad (1)$$

where

- l_0 is distance between the two marks along the same diagonal of the specimens before drying, in millimetres;
- l_1 is distance between the two marks along the same diagonal of the specimens after drying, in millimetres.

8.2 The permanent change in dimensions on firing

The permanent change in dimensions on firing, L_f , using the [Formula \(2\)](#):

$$L_f = \frac{l_2 - l_1}{l_1} \times 100 \quad (2)$$

where

- l_1 is distance between the two marks along the same diagonal of the specimens after drying, in millimetres;
- l_2 is distance between the two marks along the same diagonal of the specimens after firing, in millimetres.

8.3 The permanent change in dimensions on heating

The permanent change in dimensions on heating, L_c , using the [Formula \(3\)](#):

$$L_c = \frac{l_2 - l_0}{l_0} \times 100 \quad (3)$$

where

- l_0 is distance between the two marks along the same diagonal of the specimens before drying, in millimetres;
- l_2 is distance between the two marks along the same diagonal of the specimens after firing, in millimetres.

The permanent change in dimensions of a specimen on heating is the average value of three specimens respectively. Report the individual values calculated for each test specimen, together with the mean value, to the nearest 0,1 %. "+" stands for expansion and "-" stands for shrinkage.

The conditions of cracking of the specimens after drying and firing shall be recorded if any cracks occur.

9 Precision

9.1 Interlaboratory tests

Details of interlaboratory tests on the precision of the method are summarized in [Annex A](#). The values derived from these interlaboratory tests may not be applicable to matrices other than those given.

9.2 Repeatability

The absolute difference between two independent single test results, obtained using the same method on identical test material in the same laboratory by the same operator using the same equipment within a short interval of time, will not in more than 5 % of the cases exceed the value of the repeatability limit, r , given in [Table A.1](#).

9.3 Reproducibility

The absolute difference between two single test results, obtained using the same method on identical test material in different laboratories with different operators using different equipment, will not in more than 5 % of cases exceed the value of the reproducibility limit, R , given in [Table A.1](#).

10 Reporting

The test report shall include the following information:

- a) all information necessary for identification of the material tested, including a description of the material, manufacturer, type, brand, batch number, etc.;
- b) a reference to this document, i.e., ISO 13765-7:2021;
- c) the name of the testing establishment;
- d) in the case of a dry mortar, the mass fraction of water (or specified liquid) added;
- e) the results of the test, i.e. including the results of the individual determinations and their mean;
- f) the consistency of the mortar tested and the method used to determine the consistency, i.e. ISO 13765-1 or ISO 13765-2;
- g) the firing temperature and holding time;
- h) any deviation from the procedure specified;
- i) any unusual features (anomalies) observed during the test;
- j) the date of the test.

Annex A (informative)

Results of interlaboratory tests

Nine laboratories participated in the interlaboratory tests on the determination of permanent change in dimensions on heating of water or chemical combined refractory mortars after drying or firing respectively, i.e. experiments with four levels were carried out. Each laboratory reported eight test results for each level. The results are shown in [Table A.1](#).

Table A.1 — Results of interlaboratory tests on different refractory mortars

Level	Phosphate-bonded corundum mortars	Phosphate-bonded corundum mortars	High aluminum mortars	High aluminum mortars
	110 °C x24 h after drying	1 500 °C x3 h after firing	110 °C x24 h after drying	1 400 °C x3 h after firing
Number of laboratories	9	9	9	9
Number of laboratories retained after eliminating outliers	9	9	9	9
Mean value, %	-0,796	-0,582	-0,900	+1,113
Repeatability standard deviation, s_r	0,087	0,079	0,107	0,102
Repeatability limit, r	0,245	0,224	0,303	0,288
Reproducibility standard deviation, s_R	0,087	0,088	0,111	0,102
Reproducibility limit, R	0,245	0,248	0,315	0,288

[\(Continued from second cover\)](#)

Part 2 Determination of consistency using the reciprocating flow table method

Part 3 Determination of joint stability

Part 4 Determination of flexural bonding strength

Part 5 Determination of grain size distribution (sieve analysis)

Part 6 Determination of moisture content of ready-mixed mortars

The text of ISO standard has been approved as suitable for publication as in Indian Standard without deviations. Certain terminologies and conventions are, however, not identical with those used in Indian Standard. Attention is especially drawn to the following:

- a) Wherever the words 'International Standard' appear referring to this standard, it should be read as 'Indian Standard'; and
- b) Comma (,) has been used as a decimal marker while in Indian Standards the current practice is to use a point (.) as the decimal marker.

In this adopted standard, reference appears to certain International Standards for which Indian Standards also exists. The corresponding Indian Standards which are to be substituted in their place are listed below along with their degree of equivalence for the editions indicated:

<i>International Standard</i>	<i>Corresponding Indian Standard</i>	<i>Degree of Equivalence</i>
ISO 8656-1 Refractory products — Sampling of raw materials and unshaped products — Part 1: Sampling scheme	IS 1528 (Part 7) : 2010 Methods of sampling and physical tests for refractory materials: Part 7 Methods of sampling and criteria for conformity (<i>second revision</i>)	Technically Equivalent
ISO 13765-1 Refractory mortars — Part 1: Determination of consistency using the penetrating cone method	IS 16052 (Part 1) : 2013/ISO 13765-1 : 2004 Refractory mortars: Part 1 Determination of consistency using the penetrating cone method	Identical
ISO 13765-2 Refractory mortars — Part 2: Determination of consistency using the reciprocating flow table method	IS 16052 (Part 2) : 2013/ISO 13765-2 : 2004 Refractory mortars: Part 2 Determination of consistency using the reciprocating flow table method	Identical
ISO 13765-3 Refractory mortars — Part 3: Determination of joint stability	IS 16052 (Part 3) : 2013/ISO 13765-3 : 2004 Refractory mortars: Part 3 Determination of joint stability	Identical

In reporting the result of a test or analysis made in accordance with this standard, is to be rounded off, it shall be done in accordance with IS 2 : 2022 'Rules for rounding off numerical-values (*second revision*)'. The number of significant places retained in the rounded off value should be the same as that of the specified value in this standard.

Bureau of Indian Standards

BIS is a statutory institution established under the *Bureau of Indian Standards Act, 2016* to promote harmonious development of the activities of standardization, marking and quality certification of goods and attending to connected matters in the country.

Copyright

BIS has the copyright of all its publications. No part of these publications may be reproduced in any form without the prior permission in writing of BIS. This does not preclude the free use, in the course of implementing the standard, of necessary details, such as symbols and sizes, type or grade designations. Enquiries relating to copyright be addressed to the Head (Publication & Sales), BIS.

Review of Indian Standards

Amendments are issued to standards as the need arises on the basis of comments. Standards are also reviewed periodically; a standard along with amendments is reaffirmed when such review indicates that no changes are needed; if the review indicates that changes are needed, it is taken up for revision. Users of Indian Standards should ascertain that they are in possession of the latest amendments or edition by referring to the website-www.bis.gov.in or www.standardsbis.in.

This Indian Standard has been developed from Doc No.: MTD 15 (23720).

Amendments Issued Since Publication

Amend No.	Date of Issue	Text Affected

BUREAU OF INDIAN STANDARDS

Headquarters:

Manak Bhavan, 9 Bahadur Shah Zafar Marg, New Delhi 110002

Telephones: 2323 0131, 2323 3375, 2323 9402

Website: www.bis.gov.in

Regional Offices:

Central : 601/A, Konnectus Tower -1, 6th Floor,
DMRC Building, Bhavbhuti Marg, New
Delhi 110002

Telephones

{ 2323 7617

Eastern : 8th Floor, Plot No 7/7 & 7/8, CP Block, Sector V,
Salt Lake, Kolkata, West Bengal 700091

{ 2367 0012
2320 9474

Northern : Plot No. 4-A, Sector 27-B, Madhya Marg,
Chandigarh 160019

{ 265 9930

Southern : C.I.T. Campus, IV Cross Road, Taramani, Chennai 600113

{ 2254 1442
2254 1216

Western : Manakalya, 5th Floor/MTNL CETTM, Technology Street, Hiranandani Gardens, Powai
Mumbai 400076

{ 25700030
25702715

Branches : AHMEDABAD, BENGALURU, BHOPAL, BHUBANESHWAR, CHANDIGARH, CHENNAI, COIMBATORE, DEHRADUN, DELHI, FARIDABAD, GHAZIABAD, GUWAHATI, HARYANA (CHANDIGARH), HUBLI, HYDERABAD, JAIPUR, JAMMU, JAMSHEDPUR, KOCHI, KOLKATA, LUCKNOW, MADURAI, MUMBAI, NAGPUR, NOIDA, PARWANOO, PATNA, PUNE, RAIPUR, RAJKOT, SURAT, VIJAYAWADA.