

ब्रेज़िंग सोल्डर के रासायनिक विश्लेषण
की पद्धतियाँ
(पहला पुनरीक्षण)

Methods of Chemical Analysis
of Brazing Solder
(First Revision)

ICS 77.040.30

© BIS 2024



भारतीय मानक ब्यूरो
BUREAU OF INDIAN STANDARDS
मानक भवन, 9 बहादुर शाह ज़फर मार्ग, नई दिल्ली - 110002
MANAK BHAVAN, 9 BAHADUR SHAH ZAFAR MARG
NEW DELHI - 110002
www.bis.gov.in www.standardsbis.in

November 2024

Price Group 7

FOREWORD

This Indian Standard (First Revision) was adopted by the Bureau of Indian Standards after the draft finalized by the Methods of Chemical Analysis of Metals Sectional Committee had been approved by the Metallurgical Engineering Division Council.

This standard was first published in 1959. This revision has been brought out to bring the standard in the latest style and format of the Indian Standards. In addition, following significant modifications have been made in the current revision of the standard.

- a) References clause has been added; and
- b) The standard IS 24 : 1956 was superseded by IS 2927 : 1975, hence the scope of the standard has been modified accordingly.

The composition of the Committee responsible for the formulation of this standard is given in [Annex A](#).

In reporting the result of a test or analysis made in accordance with this standard, if the final value, observed or calculated, expressing the result of a test or analysis, shall be rounded off in accordance with IS 2 : 2022 'Rules for rounding off numerical values (*second revision*)'.

Indian Standard

METHODS OF CHEMICAL ANALYSIS OF BRAZING SOLDER

(First Revision)

1 SCOPE

1.1 This standard covers the test procedure for the chemical analysis of various grades of copper-and-copper-zinc brazing alloys (*see* IS 2927) having composition within the following range:

Sl No. (1)	Elements (2)	Percent (3)
i)	Copper	40 to 85
ii)	Lead	0.5 to 1
iii)	Cadmium	0.5 to 1.5
iv)	Tin	0.01 to 1.5
v)	Iron, <i>Max</i>	0.15
vi)	Arsenic, <i>Max</i>	0.05
vii)	Antimony, <i>Max</i>	0.05
viii)	Bismuth, <i>Max</i>	0.05
ix)	Zinc	Remainder

NOTE — The analytical procedures appear in the following order:

Sl No. (1)	Analytical Procedure (2)	Clause No. (3)
i)	Copper and lead — by the electrolytic method	5
ii)	Cadmium — by the sulphide separation (gravimetric) method	6
iii)	Iron — by the photometric method	7
iv)	Zinc — by the ferrocyanide method	8
v)	Tin — by the iodimetric method	9
vi)	Arsenic and antimony — by the distillation (iodimetric) method	10
vii)	Bismuth — by the iodine (colorimetric) method	11

2 REFERENCES

The Indian Standards given below contains provisions which, through reference in this text,

constitutes provisions of this standard. At the time of publication the edition indicated was valid. All standards are subject to revision and parties to agreement based on these standards are encouraged to investigate the possibility of applying the most recent edition of these standard:

IS No.	Title
IS 264 : 2005	Nitric acid — Specification (<i>third revision</i>)
IS 265 : 2021	Hydrochloric acid — Specification (<i>fifth revision</i>)
IS 266 : 1993	Sulphuric acid — Specification (<i>third revision</i>)
IS 1070 : 2023	Reagent grade water — Specification (<i>fourth revision</i>)
IS 2927 : 1975	Specification for brazing alloys (<i>first revision</i>)

3 SAMPLING

3.1 Samples shall be drawn by sawing the ingots selected in accordance with the procedure laid down in IS 2927.

3.2 Saw cuts shall be made in the ingot at points as indicated in [Fig. 1](#) and described in the note below the figure, in such a manner as to represent the average cross section of all ingots or bars selected for each consignment or lot of metal.

3.3 No lubricant shall be used for sawing. The sawings shall, be carefully gone over with a magnet to remove any particle of steel introduced while taking the samples.

3.4 The sawings, when thoroughly mixed, shall constitute the sample for chemical analysis and shall be taken as being representative of the consignment or lot.

To access Indian Standards click on the link below:

https://www.services.bis.gov.in/php/BIS_2.0/bisconnect/knowyourstandards/Indian_standards/isdetails/

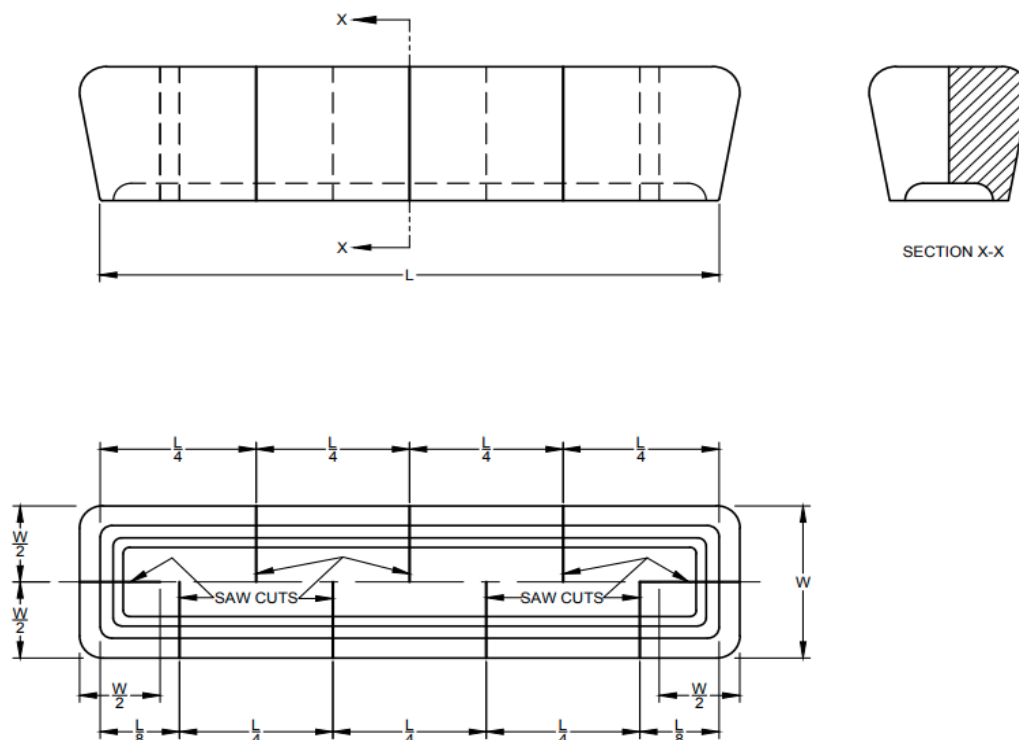

All dimensions in millimeters.

NOTE — With notched ingots the saw cuts shall be distributed along the ingot in a similar manner, avoiding, if possible, saw cuts directly through a notch.

FIG. 1 METHOD OF SAMPLING OF UN-NOTCHED INGOTS

4 QUALITY OF REAGENTS

Unless specified otherwise, pure chemicals shall be employed in tests, and distilled water (conforming to IS 1070) shall be used where the use of water as a reagent is intended.

NOTE — 'Pure chemicals' shall mean chemicals that do not contain impurities which affect the results of analysis.

5 DETERMINATION OF COPPER AND LEAD SIMULTANEOUSLY BY THE ELECTROLYTIC METHOD

5.1 Apparatus

5.1.1 Platinum Electrodes — with or without rotating stirrer

5.1.1.1 Cathode

It shall be formed either from a sheet or wire gauze and shall have a depositing surface of about 100 square cm.

5.1.1.2 Anode

It shall be in the form of either spiral or made from wire gauze. The former is recommended when the

anode serves also as a stirrer and the latter when samples contain above 0.2 percent of lead.

5.1.2 Beaker

It shall be 250 ml to 300 ml, tall-form lipless beaker with a well-fitting split cover glass.

5.2 Reagents

5.2.1 Dilute Nitric Acid — 1 : 1 and 1 : 99 (by volume)

5.2.2 Dilute Hydrochloric Acid — 0.1 N approximately

5.2.3 Ethyl Alcohol (Ethanol) — 95 percent (by volume)

5.2.4 Methyl Alcohol (Methanol) — 95 percent (by volume)

5.3 Procedure

5.3.1 Dissolve two grams of the accurately weighed sample in 25 ml of dilute nitric acid (1 : 1). Heat on a steam-bath and boil gently to expel brown fumes.

Add 50 ml of hot water and allow to stand on a steam-bath for one hour. Add paper pulp and filter off the meta-stannic acid through a close-texture filter paper into the 250 ml beaker. Wash several times with hot dilute nitric acid (1 : 99).

5.3.2 Add one drop of 0.1 N hydrochloric acid to the filtrate and dilute to 150 ml with water. Insert electrodes into the solution, cover the beaker with a pair of well-fitting split cover glass and electrolyze at a current density of 4 amperes per square decimetre using a gauze cathode. When the solution is colourless, wash down the split cover glass, electrodes and the sides of the beaker and continue the electrolysis at a lower current density of 0.3 amperes per square decimetre, until the deposition of copper is complete. This will be indicated by the failure to plate on the new exposed surface of platinum when the level of the solution is raised. When no copper appears on the cathode, it can be assumed that all lead has also been deposited on the anode. Without breaking the current, raise the electrode assembly, rinse thoroughly with water and collect the washings into the electrolyte. Reserve the electrolyte for the determination of cadmium and zinc. Dip the cathode in successive baths of ethanol or methanol and dry in an air oven at 110 °C for 3 min to 5 min and weigh for copper. Dry the anode at 110 °C to 120 °C for 30 min; the deposit being fragile should be handled with care. Cool the anode and weigh as lead peroxide.

5.4 Calculation

$$\text{Copper, percent} = \frac{A}{B} \times 100$$

$$\text{Lead, percent} = \frac{B \times 0.866}{C} \times 100$$

where

A = mass, in g, of copper;

B = mass, in g, of lead peroxide; and

C = mass, in g, of the sample used.

6 DETERMINATION OF CADMIUM BY THE SULPHIDE SEPARATION (GRAVIMETRIC) METHOD

6.1 Apparatus

6.1.1 Gooch Crucible

A loose-bottom Gooch crucible shall be used.

6.2 Reagents

6.2.1 Dilute Sulphuric Acid — 1 : 5, 1 : 4 and 1 : 1 (by volume)

6.2.2 Dilute Ammonium Hydroxide — 1 : 1 (by volume)

6.2.3 Hydrogen Sulphide — gas

6.2.4 Ammonium Chloride — solid

6.2.5 Dilute Hydrochloric Acid — 1 : 3 (by volume)

6.3 Procedure

6.3.1 Transfer the electrolyte reserved in accordance with [5.3.2](#) to a 600 ml beaker and boil to expel dissolved gases. Make the solution slightly alkaline with dilute ammonium hydroxide solution and then just neutral with dilute sulphuric acid (1 : 4). Add 25 ml of dilute sulphuric acid (1 : 4) in excess, dilute to 300 ml with water, heat to boiling and pass hydrogen sulphide gas into the solution for one hour. Allow it to stand until the precipitate has settled and filter off impure cadmium sulphide in a loose-bottom gooch crucible. Remove the precipitate by punching out the bottom of the gooch crucible into a 200 ml beaker, wash and wipe the sides of the crucible with a little asbestos pulp. Add 60 ml of dilute sulphuric acid (1 : 5) and boil for 30 min. Filter, wash and add about 5 g of ammonium chloride to the filtrate. Dilute to 300 ml with water, heat to boiling and pass hydrogen sulphide gas into the solution for one hour has settled and filter. Allow it to stand until the precipitate reserve the combined filtrate for the determination of zinc.

6.3.2 Dissolve the precipitate of cadmium sulphide in 25 ml of dilute hydrochloric acid solution in a weighed platinum dish, add 10 ml of dilute sulphuric acid (1 : 1) and evaporate to dense white fumes. Remove the excess sulphuric acid by heating the dish cautiously, and finally heat to 500 °C to 600 °C. Cool and weigh as cadmium sulphate.

6.4 Calculation

$$\text{Cadmium, percent} = \frac{A \times 0.5392}{B} \times 100$$

where

A = mass, in g, of cadmium sulphate; and

B = mass, in g, of the sample used.

7 DETERMINATION OF IRON BY THE PHOTOMETRIC METHOD

7.1 Reagents

7.1.1 Hydrobromic Acid - Bromine Mixture

Mix 20 ml of bromine with 180 ml of hydrobromic acid.

7.1.2 Perchloric Acid (HClO₄) — 70 percent

7.1.3 Hydrobromic Acid — 48 percent

7.1.4 Dilute Sulphuric Acid — 1 : 1 (by volume)

7.1.5 Test Lead

Lead containing not more than 0.000 1 percent and 0.001 percent of copper and iron respectively.

7.1.6 Sodium Acetate-Acetic Acid Buffer Solution

Dissolve 270 g of anhydrous sodium acetate in 500 ml of water, add 240 ml of acetic acid, cool and dilute to one litre.

7.1.7 Hydroxylamine Hydrochloride Solution (NH₂OH.HCl) — 10 g per litre

Dissolve one gram of the reagent in water and dilute to 100 ml.

7.1.8 Ortho-phenanthroline Solution — two grams per litre

Dissolve 0.2 g of ortho-phenanthroline monohydrate in 90 ml of water with stirring and gentle heat. Cool and dilute to 100 ml with water.

7.1.9 Standard Iron Solution — (1 ml = 0.02 mg of Fe)

Dissolve 0.140 5 g of ferrous ammonium sulphate [Fe (NH₄)₂ (SO₄)₂.6H₂O] in 100 ml of dilute hydrochloric acid (1 : 19) and dilute to one litre in a volumetric flask. Prepare fresh.

7.2 Procedure

7.2.1 Transfer up to two grams of the accurately weighed sample, from which foreign iron particles have been removed, to a 250 ml wide mouth flask. Add 20 ml of hydrobromic acid-bromine mixture. If necessary, add a few drops of bromine to ensure complete dissolution and heat in a well-ventilated hood at low temperature to dryness.

7.2.2 Add 10 ml of perchloric acid and heat with continuous swirling over an open flame in a well-ventilated hood to expel bromides of tin and antimony. When copious white fumes of perchloric acid appear, heat gently and intermittently to decompose any lead bromide that may be present. After complete removal of stannic bromide, nitric acid may be added to destroy lead bromide, if persisting. If the solution is cloudy, showing incomplete removal of tin and antimony, add 5 ml of hydrobromic acid and repeat the fuming. Repeat hydrobromic acid treatment one or more times, if

necessary, until fairly clear solution is obtained. Finally, add 15 ml of dilute sulphuric acid solution and evaporate to dense white fumes to expel perchloric acid. Continue heating until the volume of the solution has been reduced about two millilitres. Add 40 ml of water depending on the copper content of the sample under analysis, and one to two grams of test lead, and boil for 15 min. If there is any reason to suspect that the solution still contains more than two milligrams of copper, add one gram of test lead and boil for 10 min. Filter through a fine filter paper to remove lead, copper, etc.

7.2.3 Transfer the filtrate to a 100 ml volumetric flask. Dilute to 50 ml. Add 25 ml of sodium acetate-acetic acid buffer solution and shake well. Add 2 ml of hydroxylamine hydrochloride and 10 ml of o-phenanthroline solutions, dilute to the mark and shake well.

7.2.4 Transfer a suitable portion of the solution obtained in [7.2.3](#) to an absorption cell and take the photometric reading of the solution using a light filter at 490 mμ.

7.3 Calibration Curve

Take a series of standard iron solutions and a reagent blank. Using same quantities of reagents, carry through the entire stages of procedure as described under [7.2](#) and record the photometric readings of all the standard solutions along with the blank one. Construct the calibration curve by plotting the photometric readings of standard solutions against the quantities of iron.

7.4 Calculation

Convert the photometric reading of the sample to milligrams of iron by means of the calibration curve, and calculate the percentage of iron as follows:

$$\text{Iron, percent} = \frac{A}{B} \times \frac{1}{10}$$

where

A = mass, in mg, of iron found in the sample used; and

B = mass, in g, of the sample used.

8 DETERMINATION OF ZINC BY THE FERROCYANIDE METHOD

8.1 Reagents

8.1.1 Bromine Water — saturated solution

8.1.2 Concentrated Ammonium Hydroxide — specific gravity 0.90

8.1.3 Ammonium Chloride Solution

Dissolve 20 g of ammonium chloride in water and dilute to one litre.

8.1.4 Ammonium Chloride — solid**8.1.5 Dilute Sulphuric Acid — (1 : 4) by volume****8.1.6 Diphenylamine Indicator Solution**

Dissolve one gram of the reagent in 100 ml of concentrated sulphuric acid.

8.1.7 Standard Potassium Ferrocyanide Solution
[K₄Fe (CN)₆·3H₂O]

Dissolve 43.2 g of potassium ferrocyanide in one litre of water and standardize against pure zinc before use.

8.2 Procedure

8.2.1 Boil the filtrate reserved under [6.3.1](#) to expel the dissolved gases and add excess of bromine water to oxidize hydrogen sulphide. Add concentrated ammonium hydroxide until slightly alkaline and boil it gently for a few minutes. Allow the precipitate to settle for a few minutes and filter hot. Wash the beaker and the precipitate a few times alternatively with ammonium chloride solution and water. Reject the precipitate and collect the filtrate and washings in a 500 ml flask. Concentrate the solution to 200 ml, neutralize with dilute sulphuric acid and add 15 ml in excess. Add 10 g of ammonium chloride and two drops of diphenylamine indicator. Heat the solution to 60 °C and titrate with standard potassium ferrocyanide solution added at a moderate rate at first, but dropwise near the end point until the blue colour changes to a yellowish green. Just near the end point, dark blue solution turns suddenly yellowish green but changes back to blue. The end point is reached only when the yellowish green colour persists for 20 s.

NOTE — In order to get accurate results, the titration should be carried out carefully by following the procedure strictly.

8.3 Calculation

$$\text{Zinc, percent} = \frac{A \times B}{C} \times 100$$

where

A = volume, in ml, of potassium ferrocyanide solution required to titrate the sample;

B = mass, in g, of zinc which is equivalent to one millilitre of potassium ferrocyanide solution; and

C = mass, in g, of the sample taken.

9 DETERMINATION OF TIN BY THE IODIMETRIC METHOD**9.1 Apparatus**

A 500 ml conical flask fitted with a three-hole rubber stopper containing an inlet tube for carbon dioxide, an air condenser, and a hole for a burette. Thus hole shall be kept closed by means of a glass rod until the titration is started. During reduction, a very slow stream of carbon dioxide shall be passed through the flask. When the reduction is complete, the flow shall be increased to maintain a protective cover of carbon dioxide during the cooling and titration (see [Fig. 2](#)).

9.2 Reagents

9.2.1 Concentrated Hydrochloric Acid — specific gravity 1.16 (conforming to IS 265)

9.2.2 Dilute Nitric Acid — 1 : 1 (by volume)

9.2.3 Ferric Chloride Solution — (FeCl₃·6H₂O) one percent (w/v)

9.2.4 Concentrated Ammonium Hydroxide — specific gravity 0.90

9.2.5 Ammonium Chloride Solution — one percent (w/v)

9.2.6 Dilute Hydrochloric Acid — 1 : 1 and 1 : 9 (by volume)

9.2.7 Iron wire, Strip or Rod — of relatively pure iron containing not less than 99.85 percent of iron. The wire, strip or rod shall be properly cleaned before use.

9.2.8 Carbon Dioxide — oxygen-free gas

9.2.9 Antimony Chloride Solution — two percent (w/v)

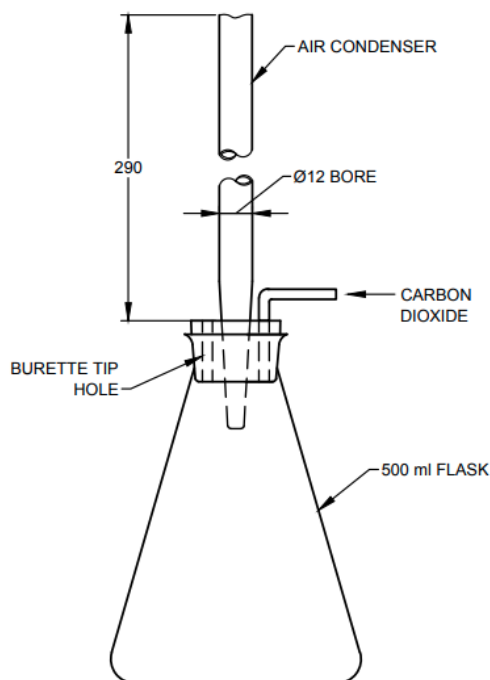

All dimensions in millimeters.

FIG. 2 APPARATUS FOR REDUCTION OF TIN

9.2.10 Starch Solution

Make a suspension of one gram of soluble starch in about 10 ml of water, and add it carefully to 100 ml of boiling water. Boil for two or three minutes and cool. Prepare the solution fresh as needed.

9.2.11 Standard Potassium Iodate Solution — 0.01 N approximately

Dissolve 0.3567 g of the recrystallized potassium iodate in 200 ml of water containing one gram of sodium hydroxide and 10 g of potassium iodide. When the solution is complete, dilute to one litre with water. Standardize against tin or an alloy of tin, copper, zinc and lead using such an amount as to give approximately the same titration as the sample to be analyzed. Reduce the tin and titrate with potassium iodate solution as described in [9.3](#).

9.2.12 Standard Iodine Solution — 0.01 N approximately

Dissolve 1.27 g of recrystallized iodine and 4 g of potassium iodide in 25 ml of water. When the solution is complete, dilute to one litre with water and store, cool place, in dark coloured glass-stoppered bottle. Standardize the iodine solution as prescribed for potassium iodate solution under [9.2.11](#).

9.3 Procedure

9.3.1 Transfer 5 g of the accurately weighed sample to a 250 ml beaker, cover and dissolve in 5 ml of concentrated hydrochloric acid and 20 ml of dilute nitric acid solution adding more concentrated hydrochloric acid, if necessary, to keep the tin in solution. Heat on a steam-bath until the solution of the sample is complete and brown fumes are expelled. Add about 10 ml of ferric chloride solution, neutralize with concentrated ammonium hydroxide and add a slight excess. Heat to boiling and filter through a rapid filter paper, and wash the beaker and precipitate several times with hot ammonium chloride solution. Dissolve the precipitate in hot dilute hydrochloric acid (1 : 1). Reprecipitate with concentrated ammonium hydroxide, boil, filter and wash thoroughly with hot ammonium chloride solution. Remove the paper and the precipitate from the funnel and place it in a 500 ml conical flask. Add 25 ml of dilute hydrochloric acid (1 : 9) and swirl the flask to break up the paper. Dilute the solution to about 200 ml. Add 60 ml of concentrated hydrochloric acid, 2 drops of antimony chloride and 5 g of iron in the form of wire, strip or rod. Fit up the apparatus as shown in [Fig. 2](#) and heat the solution to boiling with continuous evolution of gas for about 30 min. Some undissolved iron should remain after reduction.

9.3.2 After the reduction is complete, cool the contents of the flask to about 10 percent maintaining an atmosphere of carbon dioxide by passing a current of the gas in the flask. Add 5 ml of starch solution and titrate with either standard potassium iodate or standard iodine solution.

9.4 Calculation

$$\text{Tin, percent} = \frac{A \times B}{C} \times 100$$

where

A = volume, in ml, of the standard potassium iodate or iodine solution required to titrate the sample;

B = tin equivalent of the standard potassium iodate or iodine solution in g per ml; and

C = mass, in g, of the sample used.

10 DETERMINATION OF ARSENIC AND ANTIMONY BY THE DISTILLATION (IODIMETRIC) METHOD

10.1 Apparatus

An all-glass distillation apparatus as shown in [Fig. 3](#) shall be used.

10.2 Reagents

10.2.1 *Concentrated Sulphuric Acid* — specific gravity 1.84 (conforming to IS 266)

10.2.2 *Potassium Bisulphate* — solid

10.2.3 *Carbon Dioxide* — oxygen-free gas

10.2.4 *Concentrated Hydrochloric Acid* — see [9.2.1](#)

10.2.5 *Dilute hydrochloric Acid* — 1 : 1 (by volume)

10.2.6 *Hypophosphorous Acid Solution* (H₃PO₂) — 50 percent (w/v)

10.2.7 *Sodium Hydroxide Solution* — 20 percent (w/v)

10.2.8 *Methyl Red Indicator Solution*

Dissolve 0.1 g of methyl red in 60 ml of rectified spirit and make up to 100 ml with water.

10.2.9 *Sodium Bicarbonate* — solid

10.2.10 *Starch Solution* — see [9.2.10](#)

10.2.11 *Potassium Iodide Solution* — 10 percent (w/v)

10.2.12 *Sodium Sulphite* — solid

10.2.13 *Tartaric Acid Solution* — 10 percent (w/v)

10.2.14 *Standard Iodine Solution* — 0.01 N approximately

Dissolve 1.27 g of recrystallized iodine and 4 g of potassium iodide in 25 ml of water. When the solution is complete, dilute to one litre with water and store in a dark coloured glass-stoppered bottle. Standardize against pure arsenic trioxide (As₂O₃).

10.3 Procedure

10.3.1 Transfer 1.00 g to 5.00 g of the sample (depending on the arsenic and antimony content) to a 500 ml round bottom flask. Add 5 g of potassium bisulphate and 20 ml of concentrated sulphuric acid. Heat to decompose the sample avoiding very high temperature during the initial heating lest the sample should melt and incomplete decomposition may result. When the decomposition is complete, heat vigorously over an open flame to expel or wash down the sulphur on the walls of the flask. Transfer the clear solution to the distillation flask and fit up the apparatus as shown in [Fig. 3](#). Evaporate to white fumes while passing a current of carbon dioxide through the apparatus at a rate of 6 to 8 bubbles per second. Allow the solution to cool. Place a 400 ml beaker containing 50 ml of ice cold water under the condenser so that the tip of the condenser is dipped about 6 mm in water. Add 35 ml of concentrated hydrochloric acid and one millilitre of hypophosphorus acid solution in the distillation flask.

10.3.2 Place 75 ml of concentrated hydrochloric acid in the 100 ml separating funnel, and pass a stream of carbon dioxide through the apparatus. Heat the solution in the distillation flask while dropping hydrochloric acid from the separating funnel at a rate that will maintain; the temperature of the flask at 110 °C to 112 °C. Continue distillation until all the acid in the separating funnel is added.

10.4 Determination of Arsenic

10.4.1 Without disturbing the current of carbon dioxide, remove the receiver and rinse the end of the condenser with water. Preserve the solution in the distillation flask for the determination of antimony. Cool the distillate in the beaker below 30 °C; neutralize with sodium hydroxide solution using methyl red as indicator and add dilute hydrochloric acid solution to make it just acidic. Cool and add 8 g to 10 g of sodium bicarbonate, 5 ml of starch solution and one millilitre of potassium iodide solution. Titrate with 0.01 N iodine solution to a persistent blue tint.

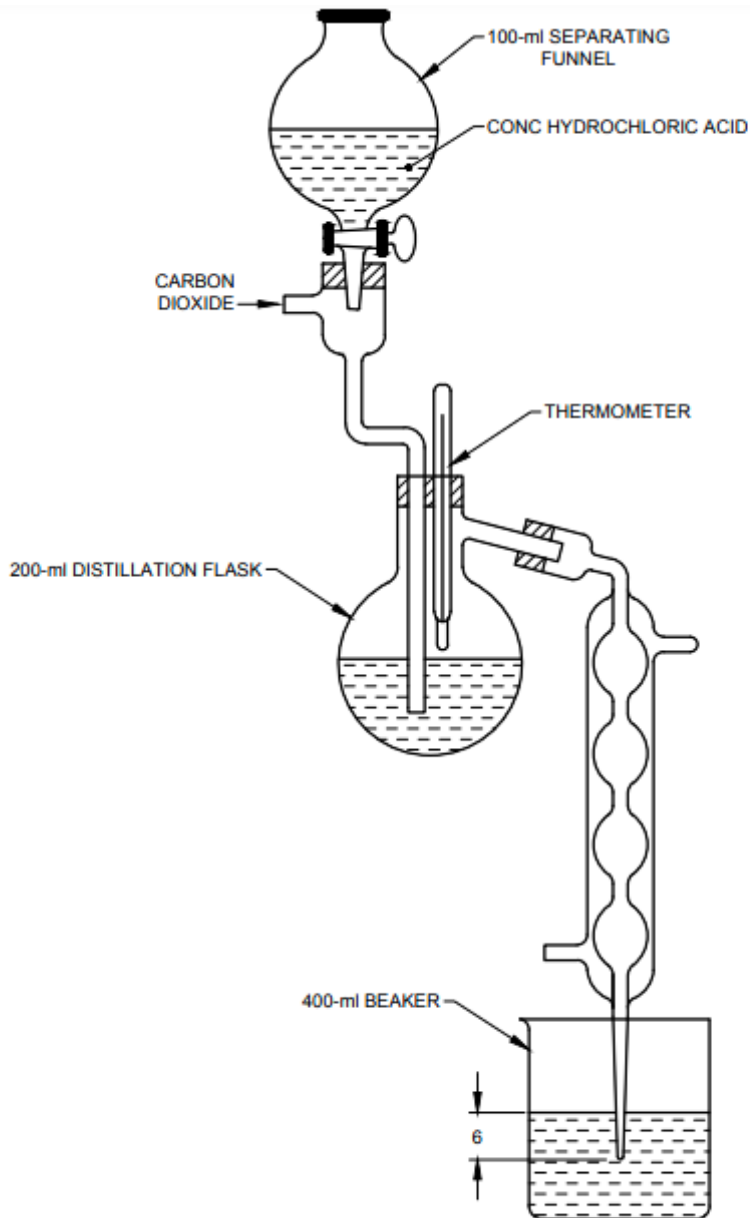

All dimensions in millimeters.

FIG. 3 APPARATUS FOR DETERMINATION OF ARSENIC AND ANTIMONY BY DISTILLATION

10.4.2 Make a blank determination following the same procedure and using the same amounts of all reagents, but without the material.

10.4.3 Calculation

$$\text{Arsenic, percent} = \frac{(A - B) C \times 0.0375}{D} \times 100$$

where

A = volume, in ml, of the standard iodine solution required to titrate the

sample;

B = volume, in ml, of the standard iodine solution required for the blank;

C = normality of the standard iodine solution; and

D = mass, in g, of the sample used.

10.5 Determination of Antimony

10.5.1 Place another 400 ml beaker containing 50 ml of ice cold water under the condenser so that the tip of the condenser is submerged about 6 mm in water. Fit up the apparatus as shown in [Fig. 3](#) and pass through it a current of carbon dioxide, at a rate of 6 to 8 bubbles, per second. Place 75 ml of concentrated hydrochloric acid in the separating funnel and distil the solution in the flask preserved under [10.4.1](#), adding hydrochloric acid at a rate sufficient to maintain the temperature of the flask between 155 °C to 158 °C. Continue the distillation until all the acid in the separating funnel has been emptied.

10.5.2 Add about one gram of sodium sulphite to the distillate in the beaker, cover it with a watch glass and place on a hot plate. Boil until the volume is reduced to 40 ml to 50 ml. Wash down the watch glass and sides of the beaker with water, replace the watch glass, and boil until the volume is reduced to 20 ml.

10.5.3 Add 80 ml of water and 10 ml of tartaric acid solution. Neutralize with sodium hydroxide solution using methyl red as indicator and add dilute hydrochloric acid solution to make it just acidic. Cool and titrate with standard iodine solution in the presence of sodium bicarbonate as described under [10.4.1](#).

10.5.4 Make a blank determination following the same procedure and using the same amount of all the reagents, but without the material.

10.5.5 Calculation

$$\text{Antimony, percent} = \frac{(A - B) C \times 0.0609}{D} \times 100$$

where

A = volume, in ml, of the standard-iodine solution required to titrate the sample;

B = volume, in ml, of the standard-iodine solution required to titrate the blank;

C = normality of the standard iodine solution; and

D = mass, in g, of the sample used.

11 DETERMINATION OF BISMUTH BY THE IODIDE (COLORIMETRIC) METHOD

11.1 Reagents

11.1.1 Concentrated Nitric Acid — specific gravity 1.42 (conforming to IS 264)

11.1.2 Ferrous Ammonium Sulphate — solid

11.1.3 Concentrated Ammonium Hydroxide — specific gravity 0.90

11.1.4 Dilute Ammonium Hydroxide — 1 : 9 (by volume)

11.1.5 Ammonium Carbonate Solution

Dissolve 100 g of ammonium carbonate in water and dilute to one litre

11.1.6 Dilute Sulphuric Acid — 1 : 4 (by volume)

11.1.7 Potassium Iodide Solution 100 ml of water

Dissolve 10 g of potassium iodide in 100 ml of water.

11.1.8 Sodium Hypophosphite Solution (Na₃PO₂)

Dissolve 20 g of sodium hypophosphite in 100 ml of water.

11.1.9 Standard Bismuth Solution — (1 ml = 0.000 1 g of Bi)

Dissolve 0.000 1 g of pure bismuth metal in 10 ml of dilute nitric acid (1 : 1), add 2 ml of concentrated sulphuric acid and evaporate to fumes. Add 20 ml of water, heat to boiling and dilute to one litre.

11.2 Procedure

11.2.1 Transfer 10 g to 50 g of the accurately weighed sample in a 400 ml beaker and add concentrated nitric acid at the rate of 40 ml per 10 g of the material. When the dissolution is complete, add 0.25 g of ferrous ammonium sulphate and boil for 2 min. Dilute to 200 ml with water and add concentrated ammonium hydroxide until the precipitated copper hydroxide is re-dissolved, and then add a little in excess. Add 10 ml of ammonium carbonate solution and heat to boiling. Allow the solution to stand overnight. Filter through a rapid filter paper and wash with hot ammonium hydroxide solution. Dissolve the precipitate through the filter paper with 20 ml of hot dilute sulphuric acid solution and wash with hot water. Re-precipitate with concentrated ammonium hydroxide, boil for 2 min and allow the precipitate to settle overnight. Filter and wash with hot dilute ammonium hydroxide solution to remove the copper completely and then twice with hot water. Dissolve the precipitate through the filter paper with 20 ml of hot dilute sulphuric acid solution, and wash thoroughly with hot water. Cool and add 10 ml of potassium iodide and 5 ml of sodium hypophosphite solutions. Allow

IS 999 : 2024

the solution to stand for 10 min. If there is a precipitate, filter it off and wash with water.

11.2.2 Transfer the clear solution to one of a pair of matched 100 ml Nessler tubes and dilute up to the 100 ml mark. In the other tube put 20 ml of dilute sulphuric acid, 10 ml of potassium iodide and 5 ml of sodium hypophosphite solutions and dilute to a few milliliters less than 100 ml mark. Into this tube, run the standard bismuth solution until the colours in the two tubes match. Not more than 4 ml of the standard bismuth solution should be used. If necessary, take an aliquot of the sample solution and dilute it to 100 ml before comparison.

11.3 Calculation

$$\text{Bismuth, percent} = \frac{A}{B} \times 0.01$$

where

A = volume, in ml, of standard bismuth solution required for matching the colour; and

B = mass, in g, of the sample used.

ANNEX A

(Foreword)

COMMITTEE COMPOSITION

Methods of Chemical Analysis of Metals Sectional Committee, MTD 34

<i>Organization</i>	<i>Representative(s)</i>
CSIR - National Metallurgical Laboratory, Jamshedpur	DR SANCHITA CHAKRAVARTY (Chairperson)
Arcelor Mittal Nippon Steel, Mumbai	SHRI MANOJ GUPTA SHRI KIRIT TAILOR (<i>Alternate</i>)
Bhabha Atomic Research Centre, Mumbai	MS SANJUKTA A. KUMAR SHRI M. V. RANA (<i>Alternate</i>)
CSIR - National Metallurgical Laboratory, Jamshedpur	DR ASHOK K. MOHANTY (<i>Alternate</i>)
Defence Metallurgical Research Laboratory, Ministry of Defence, Hyderabad	SHRI S. S. KALYAN KAMAL
Directorate General of Quality Assurance, Ministry of Defence, New Delhi	SHRI A. MITRA SHRI D. KARTIKEY (<i>Alternate</i>)
Geological Survey of India, New Delhi	SHRI NITIN PURUSHOTTAM SHRIMATI SANJUKTA DEY PAL (<i>Alternate</i>)
Hindalco Industries Limited, Mumbai	SHRI KRISHANU MAHAPATRA SHRI ASHUTOSH ACHARYA (<i>Alternate</i>)
Indian Metals and Ferro Alloys Limited, Bhubaneswar	SHRI DINESH KUMAR MOHANTY
Jawaharlal Nehru Aluminium Research Development and Design Centre, Nagpur	DR UPENDRA SINGH
JSW Steel Limited, Mumbai	SHRI KOTRABASAVARAJU SHRI MARULASIDDESHA U. M. (<i>Alternate</i>)
National Aluminium Company Limited, Bhubaneswar	SHRIMATI SUKLA NANDI SHRI DEBANANDA BHATTACHARYYA (<i>Alternate</i>)
National Test House, Kolkata	DR RAJEEV KUMAR UPADHYAY SHRI AKBAR H. (<i>Alternate</i>)
Shriram Institute for Industrial Research, Delhi	DR LAXMI RAWAT SHRI PUNEET KAPOOR (<i>Alternate</i>)
Steel Authority of India Limited - Salem Steel Plant, Salem	SHRI L. SIVAKUMAR SHRI VIVEKANANDHAN G. (<i>Alternate</i>)
Tata Steel Limited, Kolkata	DR JATIN MOHAPATRA DR RAVIKRISHNA CHATTI (<i>Alternate</i>)
BIS Directorate General	SHRI SANJIV MAINI, SCIENTIST 'F'/SENIOR DIRECTOR AND HEAD (METALLURGICAL ENGINEERING) [REPRESENTING DIRECTOR GENERAL (<i>Ex-officio</i>)]

Member Secretary

SHRI ASHISH PRABHAKAR WAKLE
SCIENTIST 'C'/DEPUTY DIRECTOR
(METALLURGICAL ENGINEERING), BIS

Bureau of Indian Standards

BIS is a statutory institution established under the *Bureau of Indian Standards Act, 2016* to promote harmonious development of the activities of standardization, marking and quality certification of goods and attending to connected matters in the country.

Copyright

BIS has the copyright of all its publications. No part of these publications may be reproduced in any form without the prior permission in writing of BIS. This does not preclude the free use, in the course of implementing the standard, of necessary details, such as symbols and sizes, type or grade designations. Enquiries relating to copyright be addressed to the Head (Publication & Sales), BIS.

Review of Indian Standards

Amendments are issued to standards as the need arises on the basis of comments. Standards are also reviewed periodically; a standard along with amendments is reaffirmed when such review indicates that no changes are needed; if the review indicates that changes are needed, it is taken up for revision. Users of Indian Standards should ascertain that they are in possession of the latest amendments or edition by referring to the website-www.bis.gov.in or www.standardsbis.in.

This Indian Standard has been developed from Doc No.: MTD 34 (20817).

Amendments Issued Since Publication

Amend No.	Date of Issue	Text Affected

BUREAU OF INDIAN STANDARDS

Headquarters:

Manak Bhavan, 9 Bahadur Shah Zafar Marg, New Delhi 110002

Telephones: 2323 0131, 2323 3375, 2323 9402

Website: www.bis.gov.in

Regional Offices:

	Telephones
Central : 601/A, Konnectus Tower -1, 6 th Floor, DMRC Building, Bhavbhuti Marg, New Delhi 110002	{ 2323 7617
Eastern : 8 th Floor, Plot No 7/7 & 7/8, CP Block, Sector V, Salt Lake, Kolkata, West Bengal 700091	{ 2367 0012 2320 9474
Northern : Plot No. 4-A, Sector 27-B, Madhya Marg, Chandigarh 160019	{ 265 9930
Southern : C.I.T. Campus, IV Cross Road, Taramani, Chennai 600113	{ 2254 1442 2254 1216
Western : 5 th Floor/MTNL CETTM, Technology Street, Hiranandani Gardens, Powai Mumbai 400076	{ 25700030 25702715

Branches : AHMEDABAD, BENGALURU, BHOPAL, BHUBANESHWAR, CHANDIGARH, CHENNAI, COIMBATORE, DEHRADUN, DELHI, FARIDABAD, GHAZIABAD, GUWAHATI, HARYANA (CHANDIGARH), HUBLI, HYDERABAD, JAIPUR, JAMMU, JAMSHEDPUR, KOCHI, KOLKATA, LUCKNOW, MADURAI, MUMBAI, NAGPUR, NOIDA, PARWANOO, PATNA, PUNE, RAIPUR, RAJKOT, SURAT, VIJAYAWADA.