



भारतीय मानक
Indian Standard

IS 18879 (Part 3) : 2024
ISO 8536-3 : 2009



चिकित्सीय उपयोग के लिए इन्फ्यूजन उपकरण

भाग 3 इन्फ्यूजन बोतलों के लिए एल्यूमीनियम कैप

Infusion Equipment for Medical Use Part 3 Aluminium Caps for Infusion Bottles

ICS 11.040.20

© BIS 2024

© ISO 2009



भारतीय मानक ब्यूरो
BUREAU OF INDIAN STANDARDS
मानक भवन, 9 बहादुर शाह ज़फर मार्ग, नई दिल्ली - 110002
MANAK BHAVAN, 9 BAHADUR SHAH ZAFAR MARG
NEW DELHI - 110002

www.bis.gov.in www.standardsbis.in

August 2024

Price Group 6

NATIONAL FOREWORD

This Indian Standard (Part 3) which is identical to ISO 8536-3 : 2009 'Infusion equipment for medical use — Part 3: Aluminium caps for infusion bottles' issued by the International Organization for Standardization (ISO), was adopted by the Bureau of Indian Standards on the recommendation of the Hospital Equipment and Surgical Disposable Products Sectional Committee and after approval of the Medical Equipment and Hospital Planning Division Council.

This Indian Standard is published in fifteen parts. The other parts in this series are:

- Part 1 Infusion glass bottles
- Part 2 Closures for infusion bottles
- Part 4 Infusion sets for single use, gravity feed
- Part 5 Burette infusion sets for single use, gravity feed
- Part 6 Freeze drying closures for infusion bottles
- Part 7 Caps made of aluminium-plastics combinations for infusion bottles
- Part 8 Infusion sets for single use with pressure infusion apparatus
- Part 9 Fluid lines for single use with pressure infusion equipment
- Part 10 Accessories for fluid lines for single use with pressure infusion equipment
- Part 11 Infusion filters for single use with pressure infusion equipment
- Part 12 Check valves for single use
- Part 13 Graduated flow regulators for single use with fluid contact
- Part 14 Clamps and flow regulators for transfusion and infusion equipment without fluid contact
- Part 15 Light-protective infusion sets for single use

Amendment 1 published in 2022 to ISO 8536-3 : 2009 is given at the end of this publication.

The text of ISO Standard has been approved as suitable for publication as an Indian Standard without deviations. Certain conventions are however, not identical to those used in Indian Standards. Attention is particularly drawn to the following:

- a) Wherever the words 'International Standard' appear referring to this standard, they should be read as 'Indian Standard'; and
- b) Comma (,) has been used as a decimal marker while in Indian Standards, the current practice is to use a point (.) as the decimal marker.

In this adopted standard, reference appears to certain International Standards for which Indian Standards also exist. The corresponding Indian Standards which are to be substituted in their respective places are listed below along with their degree of equivalence for the editions indicated:

(Continued on third cover)

Introduction

The materials from which infusion glass bottles (including elastomeric closures) are made are suitable primary packaging materials for storing infusion solutions until they are administered. However, in this part of ISO 8536, aluminium caps are not considered as primary packaging material in direct contact with the infusion solution.

Indian Standard

**INFUSION EQUIPMENT FOR MEDICAL USE
PART 3 ALUMINIUM CAPS FOR INFUSION BOTTLES**

1 Scope

This part of ISO 8536 specifies aluminium caps for infusion glass bottles which are in accordance with ISO 8536-1.

2 Normative references

The following referenced documents are indispensable for the application of this document. For dated references, only the edition cited applies. For undated references, the latest edition of the referenced document (including any amendments) applies.

ISO 2768-1, *General tolerances — Part 1: Tolerances for linear and angular dimensions without individual tolerance indications*

ISO 2768-2, *General tolerances — Part 2: Geometrical tolerances for features without individual tolerance indications*

ISO 8536-1, *Infusion equipment for medical use — Part 1: Infusion glass bottles*

ISO 8872, *Aluminium caps for transfusion, infusion and injection bottles — General requirements and test methods*

3 Dimensions and tolerances

3.1 Dimensions

The dimensions of the caps shall be as shown in Figures 1 to 3 and as given in Table 1.

The shapes of the caps are shown only as typical examples.

The components of a two-piece tear-off cap are:

- an aluminium cap with centre hole, type A;
- a protective aluminium cap with complete tear-off tab, type F.

The components of a three-piece tear-off cap are:

- an aluminium cap with centre hole, type A;
- a protective disc, E;
- a protective aluminium cap with complete tear-off tab, type F.

NOTE The width and the number of bridges for types C and F are a function of the intended resistance.

3.2 Tolerances

The tolerances shall be in accordance with ISO 2768-1 and ISO 2768-2.

4 Designation

Caps shall be designated as one-, two- or three-piece, and according to type.

The designation is expressed as the word “cap”, the number and part of ISO 8536 followed by the type letter plus the number of pieces if more than one and the nominal size of the cap.

EXAMPLE A type A two-piece aluminium cap of nominal size 32 complying with the requirements of this part of ISO 8536 is designated as follows:

Cap ISO 8536-3 - A2 - 32

5 Requirements

5.1 General requirements

5.1.1 Under normal conditions of use and handling, assembled caps shall be considered as a whole until the crimping operation.

5.1.2 The caps shall meet the requirements of ISO 8872.

5.2 Force required to remove tab

5.2.1 Three-bridge tab (type C)

The force needed to remove the tab shall be determined as specified in ISO 8872 and shall be within the range given in Table 2.

5.2.2 Complete tear-off tab (type F)

The force needed to remove the tab completely shall be determined as specified in ISO 8872 and shall be within the range given in Table 2.

5.2.3 Three-piece tear-off cap

The minimum force required to push the cap with centre hole (type A) into the protective cap with complete tear-off tab (type F) shall be 5 N.

6 Packaging

The packaging of aluminium caps shall comply with the requirements of ISO 8872.

7 Marking

The aluminium caps shall be marked in accordance with ISO 8872 and with the designation as defined in Clause 4.

Table 1 — Dimension of aluminium caps

Dimensions in millimetres

Nominal size	Type	d_1	d_2	d_4	h	e^a	r	
		$+0,1$ $-0,05$	$\pm 0,2$	min.	$\pm 0,25$			$\pm 0,2$
28	A, C	28,1	12 to 21		8,6 to 9,0	0,168 < e < 0,242	1	
	Disc E			27,3				
	F		15 to 21				1	
32	A, C	32,6	15 to 21		11,9			1
	Disc E			30				
	F		15 to 21				1	

^a The thickness shall be agreed upon between the manufacturer and the user within the given range. The thickness shall not differ from the nominal value by more than 0,022 mm. The extreme limits are given without tolerance.

Dimensions in millimetres

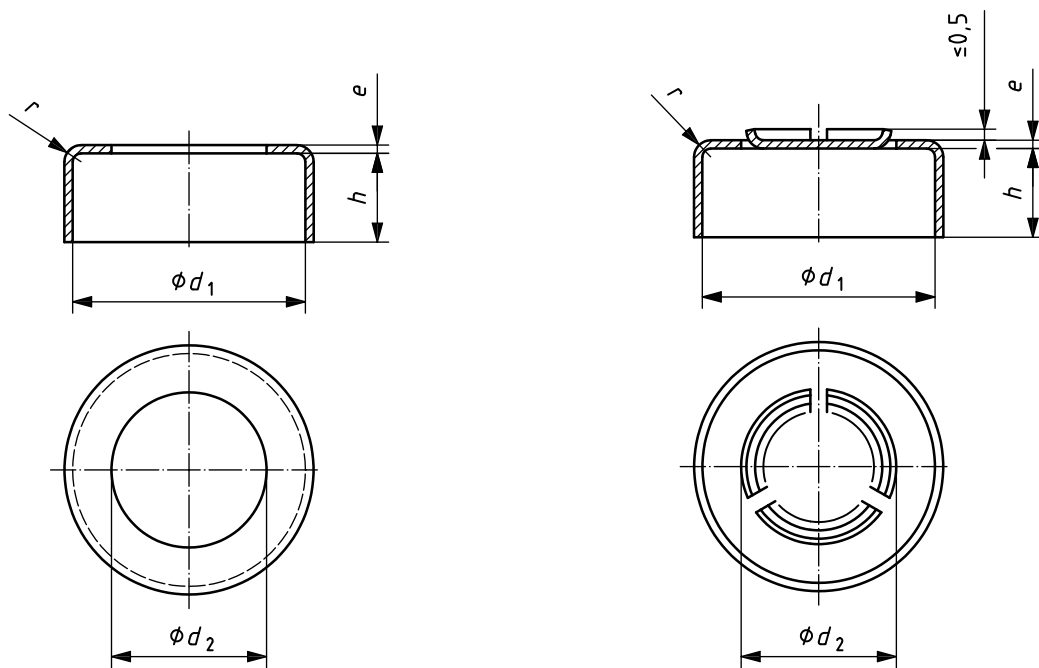

a) Type A — Aluminium cap with centre hole

b) Type C — Aluminium cap with three-bridge tab

Figure 1 — One-piece tear-off cap

Dimensions in millimetres

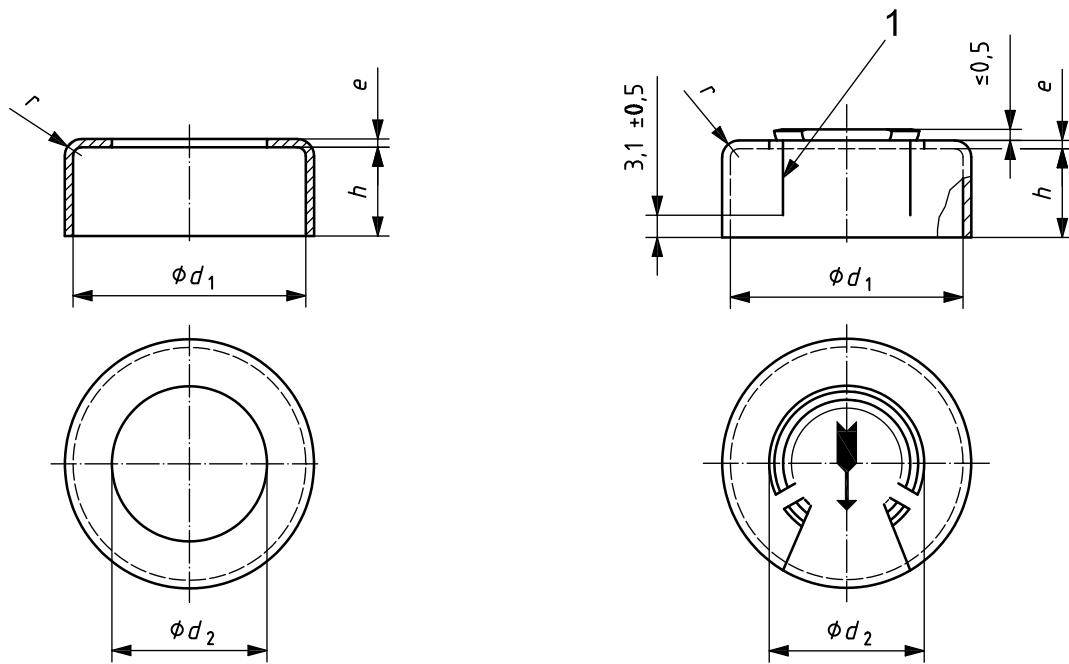

a) Type A — Aluminium cap with centre hole

b) Type F — Protective aluminium cap with complete tear-off tab

Key

1 tear-off perforation

Figure 2 — Two-piece tear-off cap

Dimensions in millimetres

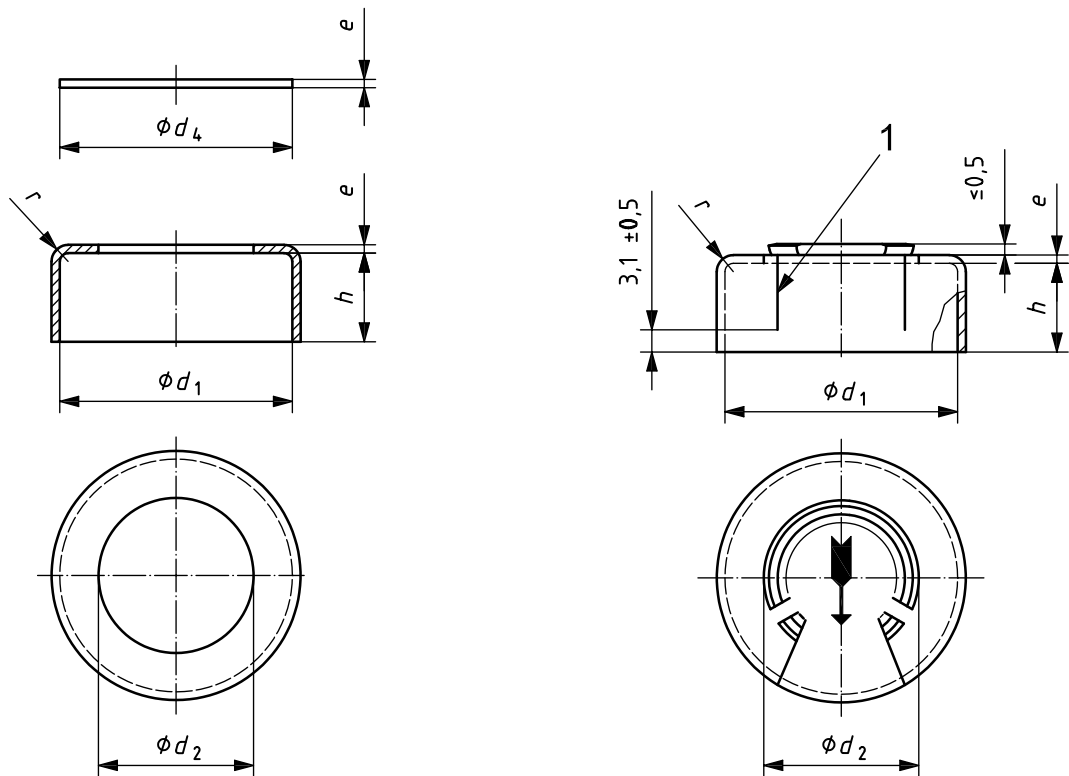

a) Type A — Aluminium cap with centre hole

b) Type F — Protective aluminium cap with complete tear-off tab

Key

1 tear-off perforation

Figure 3 — Three-piece tear-off cap

Table 2 — Minimum and maximum forces to remove the complete tear-off tab (type F) or three-bridge tab (type C)

Nominal size	Force to break bridges		Force to tear off tab completely	
	min.	N max.	min.	N max.
28	10	40	5	25
32	30	60	20	40

NOTE In the case of multiple bridges, the resistance against pressure shall be sufficient, but the breaking force is reduced accordingly.

NATIONAL ANNEX A

[*\(National Foreword\)*](#)

A-1 BIS CERTIFICATION MARKING

The product(s) conforming to the requirements of this standard may be certified as per the conformity assessment schemes under the provisions of the *Bureau of Indian Standards Act, 2016* and the Rules and Regulations framed thereunder, and the product(s) may be marked with the Standard Mark.

[\(Continued from second cover\)](#)

<i>International Standard</i>	<i>Corresponding Indian Standard</i>	<i>Degree of Equivalence</i>
ISO 2768-1 General tolerances — Part 1: Tolerances for linear and angular dimensions without individual tolerance indications	IS 2102 (Part 1) : 1993/ ISO 2768-I : 1989 General tolerances: Part 1 Tolerances for linear and angular dimensions without individual tolerance indications (<i>third revision</i>)	Identical
ISO 2768-2 General tolerances — Part 2: Geometrical tolerances for features without individual tolerance indications	IS 17894 : 2022/ISO 22081 : 2021 Geometrical product specifications (GPS) — Geometrical tolerancing — General geometrical specifications and general size specifications	Technically Equivalent
ISO 8536-1 Infusion equipment for medical use — Part 1: Infusion glass bottles	IS/ISO 8536-1 : 2011 Infusion Equipment for medical use: Part 1 Infusion glass bottles	Identical

The technical committee has reviewed the provisions of the following International Standards referred in this adopted standard and has decided that they are acceptable for use in conjunction with this standard:

<i>International Standard</i>	<i>Title</i>
ISO 8872	Aluminium caps for transfusion, infusion and injection bottles — General requirements and test methods

This standard also makes a reference to the BIS Certification Marking of the product. Details of which is given in [National Annex A](#).

For the purpose of deciding whether a particular requirement of this standard is complied with, the final value, observed or calculated, expressing the result of a test shall be rounded off in accordance with IS 2 : 2022 'Rules for rounding off numerical values (*second revision*)'.

Bureau of Indian Standards

BIS is a statutory institution established under the *Bureau of Indian Standards Act, 2016* to promote harmonious development of the activities of standardization, marking and quality certification of goods and attending to connected matters in the country.

Copyright

BIS has the copyright of all its publications. No part of these publications may be reproduced in any form without the prior permission in writing of BIS. This does not preclude the free use, in the course of implementing the standard, of necessary details, such as symbols and sizes, type or grade designations. Enquiries relating to copyright be addressed to the Head (Publication & Sales), BIS.

Review of Indian Standards

Amendments are issued to standards as the need arises on the basis of comments. Standards are also reviewed periodically; a standard along with amendments is reaffirmed when such review indicates that no changes are needed; if the review indicates that changes are needed, it is taken up for revision. Users of Indian Standards should ascertain that they are in possession of the latest amendments or edition by referring to the website-www.bis.gov.in or www.standardsbis.in.

This Indian Standard has been developed from Doc No.: MHD 12 (25422).

Amendments Issued Since Publication

Amend No.	Date of Issue	Text Affected

BUREAU OF INDIAN STANDARDS

Headquarters:

Manak Bhavan, 9 Bahadur Shah Zafar Marg, New Delhi 110002

Telephones: 2323 0131, 2323 3375, 2323 9402

Website: www.bis.gov.in

Regional Offices:

	Telephones
Central : 601/A, Konnectus Tower -1, 6 th Floor, DMRC Building, Bhavbhuti Marg, New Delhi 110002	{ 2323 7617
Eastern : 8 th Floor, Plot No 7/7 & 7/8, CP Block, Sector V, Salt Lake, Kolkata, West Bengal 700091	{ 2367 0012 2320 9474
Northern : Plot No. 4-A, Sector 27-B, Madhya Marg, Chandigarh 160019	{ 265 9930
Southern : C.I.T. Campus, IV Cross Road, Taramani, Chennai 600113	{ 2254 1442 2254 1216
Western : Manakalya, 5 th Floor/MTNL CETTM, Technology Street, Hiranandani Gardens, Powai Mumbai 400076	{ 25700030 25702715

Branches : AHMEDABAD, BENGALURU, BHOPAL, BHUBANESHWAR, CHANDIGARH, CHENNAI, COIMBATORE, DEHRADUN, DELHI, FARIDABAD, GHAZIABAD, GUWAHATI, HARYANA (CHANDIGARH), HUBLI, HYDERABAD, JAIPUR, JAMMU, JAMSHEDPUR, KOCHI, KOLKATA, LUCKNOW, MADURAI, MUMBAI, NAGPUR, NOIDA, PARWANOO, PATNA, PUNE, RAIPUR, RAJKOT, SURAT, VIJAYAWADA.