

न्यूरोसर्जिकल उपकरण — सुई
धारक — आकार और आयाम
(पहला पुनरीक्षण)

Neurosurgical Instruments —
Needle Holder — Shape and
Dimensions
(First Revision)

ICS 11.040.30

© BIS 2024



भारतीय मानक ब्यूरो
BUREAU OF INDIAN STANDARDS
मानक भवन, 9 बहादुर शाह ज़फर मार्ग, नई दिल्ली - 110002
MANAK BHAVAN, 9 BAHADUR SHAH ZAFAR MARG
NEW DELHI - 110002
www.bis.gov.in www.standardsbis.in

September 2024

Price Group 6

FOREWORD

This Indian Standard (First Revision) was adopted by the Bureau of Indian Standards after the draft finalized by the Neurosurgery Instruments, Implants and Accessories Sectional Committee had been approved by the Medical Equipment and Hospital Planning Division Council.

This standard was first published in 1991. The revision of this standard has been brought out to align it with recent developments and to bring the standard in line with the latest style and format of Indian Standards.

It has been revised to cover the requirements in respect of shape and dimensions only, as the specification part of these types of instruments is covered in IS 3642 (Part 1) : 1990 'Surgical instruments — Specification: Part 1 Non-cutting, articulated instruments (*second revision*)'. This standard is, therefore, intended to be used only in respect of shape and dimensions, which are referred to in **4.1** of IS 3642 (Part 1).

The composition of the Committee responsible for formulation of this standard is given in [Annex A](#).

For the purpose of deciding whether a particular requirement of this standard is complied with the final value, observed or calculated, expressing the result of a test or analysis shall be rounded off in accordance with IS 2 : 2022 'Rules for rounding off numerical values (*second revision*)'. The number of significant places retained in the rounded off value should be same as that of the specified value in this standard.

Indian Standard

NEUROSURGICAL INSTRUMENTS — NEEDLE HOLDER — SHAPE AND DIMENSIONS

*(First Revision)***1 SCOPE**

This standard prescribes shape and dimensions for needle holder used in neurosurgery.

2 REFERENCES

The standard given below contain provisions, which, through reference in this text, constitute provisions of this standard. At the time of publication, the editions indicated was valid. All Standards are subject to revision, and parties to agreements based on this standard are encouraged to investigate the possibility of applying the most recent edition of this standards.

<i>IS No.</i>	<i>Title</i>
IS 3642 (Part 1): 1990	Surgical instruments — Specification: Part 1 Non-cutting, articulated instruments (<i>second revision</i>)

3 SHAPE AND DIMENSIONS

3.1 The shape and dimensions holder shall be as shown in [Fig. 1](#).

3.2 Joint

The joint shall be of box type in accordance with **13.2.2** of IS 3642 (Part 1).

3.3 Ratchet

Ratchet teeth shall conform to Section 4 of IS 3642 (Part 1) with a combination of 3 in 3.

3.3.1 The ratchet teeth shall be designed such that the load at which the first ratchet just engages shall be between 2.0 kg to 2.5 kg.

3.4 Finger Loop

The finger loop shall conform to size no. 1 of Section 6 of IS 3642 (Part 1).

3.5 Bows

The bows of needle holder shall be gold plated.

3.6 Jaws

The needle holder shall have tungsten carbide insert jaws with matt finish.

3.7 Serrations

These shall be cross type serrations in accordance with Fig. 2C of IS 3642 (Part 1).

4 MARKING

Each Holder shall be marked with the following:

- a) Manufacturer's name, initials or registered trade-mark in the space provided on country of manufacture;
- b) Serial number; and
- c) Batch number.

5 BIS CERTIFICATION MARKING

The product(s) conforming to the requirements of this standard may be certified as per the conformity assessment schemes under the provisions of the *Bureau of Indian Standards Act, 2016* and the Rules and Regulations framed thereunder, and the product(s) may be marked with the Standard Mark.

6 PACKAGING

Each product shall be wrapped in a moisture-proof paper or polyethylene bag and packed in a suitable cardboard carton. The packing may also be done as agreed between the purchaser and the supplier. On the package of the product batch number, lot number, and serial number shall be mentioned.

To access Indian Standards click on the link below:

https://www.services.bis.gov.in/php/BIS_2.0/bisconnect/knowyourstandards/Indian_standards/isdetails/

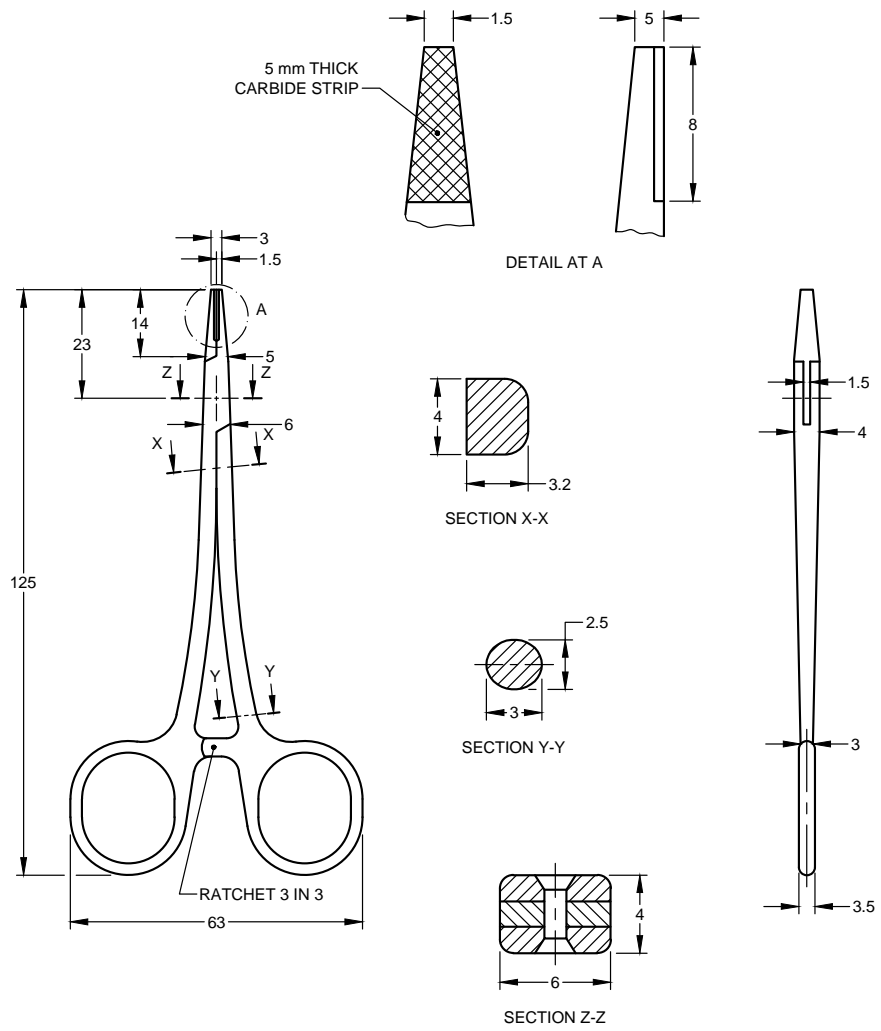

FIG. 1 NEEDLE HOLDER

ANNEX A

(Foreword)

COMMITTEE COMPOSITION

Neurosurgery Instruments Implants and Accessories Sectional Committee, MHD 07

<i>Organization</i>	<i>Representative(s)</i>
G B Pant Hospital, New Delhi	DR DALJIT SINGH (<i>Chairperson</i>)
Abbott Healthcare India Private Limited, Mumbai	MS LIPI CHAKHAIYAR MS SHWETA SHARMA (<i>Alternate</i>)
Association of Indian Medical Device Industry, New Delhi	SHRI NAVEEN KHANNA SHRI PUHAZHENDI KALIYAPPAN (<i>Alternate I</i>) SHRI ANKUR BHARGAVA (<i>Alternate II</i>)
Boston Scientific India Private Limited, Gurugram	SHRI DEV CHOPRA SHRI PRASHANTH PRABHAKAR (<i>Alternate</i>)
Central Drugs Standard Control Organization, New Delhi	SHRI ASEEM SAHU MS SHYAMNI SASIDHARAN (<i>Alternate</i>)
Defence Bio-Engineering and Electromedical Laboratory, Ministry of Defence, Bengaluru	SHRI JAYANT DANIEL SHRI G. SRIPATHY (<i>Alternate</i>)
Directorate General of Health Services, New Delhi	DR. AJAY CHOUDHARY DR K. B. SHANKER (<i>Alternate</i>)
Happy Reliable Surgeries Private Limited, Bengaluru	SHRI. HEMANT SAVALE SHRI SANJEEV GAUTAM (<i>Alternate</i>)
Indian Institute of Technology Hyderabad, Hyderabad	SHRI AVINASH ERANKI SHRI KOUSIK SARATHY S. (<i>Alternate</i>)
Kalam Institute of Health Technology, Vishakhapatnam	SHRI SANTOSH KUMAR BALIVADA MS DIVYA ANIL PATIL (<i>Alternate I</i>) MS PURVA SUHAS PHALKE (<i>Alternate II</i>)
Skull Base Surgery Society of India, Chennai	DR HARSH DEORA
In Personal Capacity (<i>Office Floor, The Suryaa Hotel, New Friends Colony. New Delhi - 110025</i>)	SHRI ASOK KUMAR RAGHAVAN NAIR
BIS Directorate General	SHRI A. R. UNNIKISHNAN, SCIENTIST 'G' AND HEAD (MEDICAL EQUIPMENT AND HOSPITAL PLANNING) [REPRESENTING DIRECTOR GENERAL (<i>Ex-officio</i>)]

Member Secretary

MS HARSHADA GANESH KADAM
SCIENTIST 'B'/ASSISTANT DIRECTOR
(MEDICAL EQUIPMENT AND HOSPITAL PLANNING), BIS

Bureau of Indian Standards

BIS is a statutory institution established under the *Bureau of Indian Standards Act, 2016* to promote harmonious development of the activities of standardization, marking and quality certification of goods and attending to connected matters in the country.

Copyright

BIS has the copyright of all its publications. No part of these publications may be reproduced in any form without the prior permission in writing of BIS. This does not preclude the free use, in the course of implementing the standard, of necessary details, such as symbols and sizes, type or grade designations. Enquiries relating to copyright be addressed to the Head (Publication & Sales), BIS.

Review of Indian Standards

Amendments are issued to standards as the need arises on the basis of comments. Standards are also reviewed periodically; a standard along with amendments is reaffirmed when such review indicates that no changes are needed; if the review indicates that changes are needed, it is taken up for revision. Users of Indian Standards should ascertain that they are in possession of the latest amendments or edition by referring to the website-www.bis.gov.in or www.standardsbis.in.

This Indian Standard has been developed from Doc No.: MHD 07 (25836).

Amendments Issued Since Publication

Amend No.	Date of Issue	Text Affected

BUREAU OF INDIAN STANDARDS

Headquarters:

Manak Bhavan, 9 Bahadur Shah Zafar Marg, New Delhi 110002

Telephones: 2323 0131, 2323 3375, 2323 9402

Website: www.bis.gov.in

Regional Offices:

	Telephones
Central : 601/A, Konnectus Tower -1, 6 th Floor, DMRC Building, Bhavbhuti Marg, New Delhi 110002	{ 2323 7617
Eastern : 8 th Floor, Plot No 7/7 & 7/8, CP Block, Sector V, Salt Lake, Kolkata, West Bengal 700091	{ 2367 0012 2320 9474
Northern : Plot No. 4-A, Sector 27-B, Madhya Marg, Chandigarh 160019	{ 265 9930
Southern : C.I.T. Campus, IV Cross Road, Taramani, Chennai 600113	{ 2254 1442 2254 1216
Western : 5 th Floor/MTNL CETTM, Technology Street, Hiranandani Gardens, Powai Mumbai 400076	{ 25700030 25702715

Branches : AHMEDABAD, BENGALURU, BHOPAL, BHUBANESHWAR, CHANDIGARH, CHENNAI, COIMBATORE, DEHRADUN, DELHI, FARIDABAD, GHAZIABAD, GUWAHATI, HARYANA (CHANDIGARH), HUBLI, HYDERABAD, JAIPUR, JAMMU, JAMSHEDPUR, KOCHI, KOLKATA, LUCKNOW, MADURAI, MUMBAI, NAGPUR, NOIDA, PARWANOO, PATNA, PUNE, RAIPUR, RAJKOT, SURAT, VIJAYAWADA.