रबर गैस्केट — विशिष्टि

(पहला पुनरीक्षण)

Rubber Gaskets — Specification

(First Revision)

ICS 23.040.80; 83.060; 83.140.50

© BIS 2024



भारतीय मानक ब्यूरो
BUREAU OF INDIAN STANDARDS
मानक भवन, 9 बहादुर शाह ज़फर मार्ग, नई दिल्ली - 110002
MANAK BHAVAN, 9 BAHADUR SHAH ZAFAR MARG
NEW DELHI - 110002

www.bis.gov.in www.standardsbis.in

October 2024

Price Group 8

FOREWORD

This Indian Standard (First Revision) was adopted by the Bureau of Indian Standards, after the draft finalized by the Chemical Engineering Plants and Related Equipment Sectional Committee had been approved by the Mechanical Engineering Divisional Council.

This standard was first issued in 1984. This revision has been taken up with a view incorporating the modification found necessary as a result of experience gained in the use of this standard. Also, in this revision, the standard has been brought into the latest style and format of Indian Standards, and references to Indian Standards, wherever applicable have been updated.

The vulcanized rubber gaskets covered by this standard are used in water, steam (low pressure), gas installations, diesel engines, etc.

In this revision, amendment has been incorporated. The following major modifications have been incorporated in this revision of the standard:

- a) Scope has been revised to add foam rubber gaskets;
- b) Acid resistant gaskets (Type V) has been added;
- c) The unit of hardness changed from IRHD to Shore A scale; and
- d) Method of determination of hardness in Shore A scale has been added.

The composition of the Committee responsible for the formulation of this standard is given in [Annex E](#).

For the purpose of deciding whether a particular requirement of this standard is complied with, the final value, observed or calculated, expressing the result of a test or analysis, shall be rounded off in accordance with IS 2 : 2022 'Rules for rounding off numerical values (*second revision*)'. The number of significant places retained in the rounded off value should be the same as that of the specified value in this standard.

Indian Standard
RUBBER GASKETS — SPECIFICATION
(First Revision)

1 SCOPE

1.1 This standard specifies different types of rubber gaskets, their characteristics and applications.

1.2 The standard is divided in 2 sections as follows:

- a) Section I — Rubber gaskets of five different types for various applications. Each type is divided into a number of classes in different hardness ranges; and
- b) Section II — Foam rubber gaskets of different material for various applications.

2 REFERENCES

The standards listed in [Annex A](#) contain provisions which through reference in this text, constitute provisions of this standard. At the time of publication, the editions indicated were valid. All standards are subject to revision, and parties to agreements based on this standard are encouraged to investigate the possibility of applying the most recent edition of the standards.

3 TERMINOLOGY

For the purpose of this standard, the following definitions shall apply:

3.1 Gasket — Deformable material (or combination of materials) intended to be clamped between flanges to prevent leakage of contained fluid.

SECTION I RUBBER GASKETS**4 TYPES AND CLASSES****4.1 Types**

Vulcanized rubber gaskets shall be of five types depending upon the service conditions and applications as follows:

<i>Sl No.</i>	<i>Type</i>	<i>Application</i>
(1)	(2)	(3)
i)	I	General purpose gaskets having superior physical properties.
ii)	II	General purpose gaskets having moderately good physical properties.

<i>Sl No.</i>	<i>Type</i>	<i>Application</i>
(1)	(2)	(3)
iii)	III	Oil resistant gaskets suitable for lubricating oil and fuels.
iv)	IV	Heat and oil resistant gaskets.
v)	V	Acid resistant gaskets.

4.2 Classes

There shall be five classes in Type I, three classes each in Type II, III and V, and 2 or 3 classes (based on temperature and material) in Type IV depending upon their hardness as given [Table 1](#) to [Table 5](#).

5 REQUIREMENTS**5.1 Polymer**

The polymer or blends of polymers shall be as given under each type. However, other polymers as agreed to between purchaser and supplier may be used provided all other test requirements are satisfied. All the constituent of the mix shall be free from foreign matter and grit.

5.2 Workmanship and Finish

The gaskets shall be free from all such defects which may be detrimental to performance.

5.3 Thickness

The recommended thicknesses of the rubber gaskets shall be as per requirement.

5.4 Tolerances on Specified Dimensions

Tolerances on specified dimensions shall be as agreed to between the purchaser and the supplier.

6 SPECIFIC REQUIREMENTS FOR TYPE I

6.1 This type refers to gaskets having superior physical properties, and useful at temperatures up to 70 °C, not resistant to oils or solvents. Either natural or synthetic rubber or a blend thereof shall be used in the manufacture of these gaskets. Use of reclaimed rubber or ground vulcanized rubber is not permitted.

6.2 The gaskets are classified in five classes (A, B, C, D, and E) and their physical properties shall be as given in [Table 1](#).

6.3 Accelerated Ageing

The maximum variation of hardness after ageing at $70\text{ }^{\circ}\text{C} \pm 1\text{ }^{\circ}\text{C}$ for 72 h in accordance with the method prescribed under [11.3](#) shall not be more than ± 5 Shore A. The tensile strength shall not vary more than + 10 percent and ultimate elongation shall not vary more than - 15 percent when tested in accordance with the method prescribed under [11.3](#).

6.4 Water Absorption

The gaskets shall not absorb more than 10 percent water by weight, when tested as prescribed in [Annex B](#). If the gaskets are to be used for food products, the water shall be free from turbidity, odour, or taste at the end of the test.

7 SPECIFIC REQUIREMENTS FOR TYPE II

7.1 This type refers to gaskets having moderately good physical properties and not intended for use in stringent working conditions. Either natural

or synthetic rubber or a blend thereof may be used in their manufacture. Reclaimed rubber and ground vulcanized rubber may also be used.

7.2 The gaskets are divided in three classes (2A, 2B, and 2C) and their physical properties shall be as given in [Table 2](#).

7.3 Accelerated Ageing

The maximum variation of hardness after ageing at $70\text{ }^{\circ}\text{C} \pm 1\text{ }^{\circ}\text{C}$ for 72 h in accordance with method prescribed in [11.3](#) shall be more than ± 5 Shore A. The tensile strength shall not vary by more than + 10 percent and ultimate elongation shall not vary more than - 35 percent from that of unaged samples.

8 SPECIFIC REQUIREMENTS FOR TYPE III OIL RESISTANT GASKETS

8.1 The gaskets shall be suitable for oil and heat resistant applications up to $121\text{ }^{\circ}\text{C}$ temperature. Basic polymer (nitrile or polychloroprene) shall be used in their manufacture.

8.2 The physical properties of these gaskets shall be as given in [Table 3](#).

Table 1 Physical Properties of Type I Gaskets

(Clauses [4.2](#) and [6.2](#))

SI No.	Physical Properties	Class				
		1A	1B	1C	1D	1E
(1)	(2)	(3)	(4)	(5)	(6)	(7)
i)	Hardness, Shore A	41 to 50	51 to 60	61 to 70	71 to 80	81 to 90
ii)	Tensile strength, (kg/cm ²), <i>Min</i>	200	175	175	140	120
iii)	Ultimate elongation (percent), <i>Min</i>	500	450	400	350	200
iv)	Compression set at $70\text{ }^{\circ}\text{C}$, <i>Max</i>	20	25	30	35	40

Table 2 Physical Properties of Type II Gaskets

(Clauses [4.2](#) and [7.2](#))

SI No.	Physical Properties	Class		
		2A	2B	2C
(1)	(2)	(3)	(4)	(5)
i)	Hardness (A), Shore A	51 to 60	61 to 70	71 to 80
ii)	Tensile strength, (kg/cm ²), <i>Min</i>	85	70	60
iii)	Ultimate elongation (percent), <i>Min</i>	200	250	200
iv)	Compression set at $70\text{ }^{\circ}\text{C}$, <i>Max</i>	35	35	45

Table 3 Physical Properties of Type III Gaskets

(Clauses 4.2 and 8.2)

SI No.	Physical properties	Class		
		3A (3)	3B (4)	3C (5)
(1)	(2)			
i)	Hardness (A), Shore A	50 ± 5	60 ± 5	70 ± 5
ii)	Tensile strength, (kg/cm ²), <i>Min</i>	100	140	170
iii)	Elongation at break (percent), <i>Min</i>	300	300	300
iv)	Compression set (100 °C for 22 h), <i>Max</i>	25	25	25
v)	Accelerated ageing (100 °C for 70 h)			
		<i>Nitrile</i>		<i>Polychloroprene</i>
a)	Change in hardness (A)	± 10		+ 15
b)	Change in tensile strength (percent)	- 20		- 15
c)	Change in elongation at break (percent)	- 30		- 40
vi)	Ageing in oil no. 1 (100 °C for 70 h)			
a)	Change in hardness (A)	± 10		± 10
b)	Change in tensile strength (percent)	- 20		- 30
c)	Change in elongation at break (percent)	- 20		- 30
d)	Change in volume (percent)	± 10		- 10 to + 15
vii)	Ageing in fuel A (23 °C for 70 h)			
a)	Change in hardness (A)	± 10		-
b)	Change in tensile strength (percent)	- 25		-
c)	Change in elongation at break (percent)	- 25		-
d)	Change in volume (percent)	- 5 to + 10		-

NOTE — Properties of oil and fuel shall be as follows:

a) Oil:

- 1) Flashpoint: 171;
- 2) Density at 15 °C 920 kg/m³;
- 3) Flash point cleveland 171 °C;
- 4) Kinematic viscosity at 40 °C 29.5 mm²/s;
- 5) Kinematic viscosity at 100 °C 4.3 mm²/s; and
- 6) Pourpoint -33 °C.

b) Fuel:

- 1) Density at 15 °C 882 kg/m³;
- 2) Flash point cleveland 243 °C;
- 3) Kinematic viscosity at 40 °C 213 mm²/s.
- 4) Kinematic viscosity at 100 °C 19.1 mm²/s; and
- 5) Pourpoint - 12 °C.

8.3 Accelerated Ageing

The maximum variation of hardness after ageing at $100\text{ }^{\circ}\text{C} \pm 2\text{ }^{\circ}\text{C}$ for 70 h in accordance with method prescribed under [11.3](#) shall not be more than ± 15 Shore A. The tensile strength shall not vary by more than + 10 percent and elongation by - 35 percent from that of unaged sample.

8.4 Ageing in Oil

After ageing in applicable oil (*see* Note) at $100\text{ }^{\circ}\text{C} \pm 2\text{ }^{\circ}\text{C}$ for 72 h, the hardness Shore A shall not vary by more ± 8 points, the tensile strength shall not vary by more than - 35 percent and volume by $\pm 8^{+20}$ percent with respect to actual values recorded before ageing.

NOTE — Additives used in various oils can affect the performance of rubber and hence while selecting the polymer, compatibility with oil under application needs to be established.

8.5 Ageing in Iso-octane

After ageing in iso-octane [*see* 'Liquid A' in Table A-1 IS 3400 (Part 6)/ISO 1817] at $70\text{ }^{\circ}\text{C} \pm 2\text{ }^{\circ}\text{C}$ for 70 h, Shore A shall not vary more than $-_{13}^{+0}$ Shore A, the tensile strength shall not vary by more than + 0 percent to - 40 percent and volume shall not vary by more than + 12 percent with respect to actual values recorded before ageing.

9 SPECIFIC REQUIREMENTS FOR TYPE IV

9.1 This type refers to gaskets having good to excellent heat and oil resistance properties. Basic polymer such as alkyl acrylate copolymer (ACM) (polyacrylate), FKM (fluorocarbon-based fluoroelastomer), or silicone rubber shall be used in their manufacture.

9.2 The gaskets are divided into three classes and their physical properties shall be as given in [Table 4](#).

Table 4A Physical Properties of Type IV Gaskets

(Clauses [4.2](#) and [9.2](#))

Sl No.	Physical properties	Class		
		4A (3)	4B (4)	4C (5)
(1)	(2)			
i)	Hardness (A), Shore A	50 ± 5	60 ± 5	70 ± 5
ii)	Tensile strength, (kg/cm ²), <i>Min</i>	70	80	80
iii)	Elongation at break (percent), <i>Min</i>	225	175	150
iv)	Compression set (175 °C for 22 h), <i>Max</i>	60	60	60
v)	Accelerated ageing (150 °C for 70 h)			
a)	Change in hardness (A)		+ 10	
b)	Change in tensile strength (percent)		- 25	
c)	Change in elongation at break (percent)		- 30	
vi)	Ageing in oil no.1 (150 °C for 70 h)			
a)	Change in hardness (A)		- 8 to 15	
b)	Change in tensile strength (percent)		- 20	
c)	Change in elongation at break (percent)		- 30	
d)	Change in volume (percent)		- 5 to 10	

9.3 Accelerated Ageing

The maximum variation of hardness after ageing at 100 °C ± 2 °C for 72 h in accordance with method prescribed under 11.3 shall not be more than ± 15 Shore A. Tensile strength and ultimate elongation shall not vary beyond the value given below:

Tensile strength ± 20 percent, elongation at break $\begin{matrix} +10 \\ -25 \end{matrix}$ percent from that of unaged sample.

9.4 Ageing in Oil

After ageing in applicable oil (*see* note) at 100 °C ± 2 °C Shore A for 72 h, the hardness shall not vary by more than ±8 percent, the tensile

strength shall not vary by more than – 35 percent and volume by $\begin{matrix} +20 \\ -8 \end{matrix}$ percent with respect to actual values recorded before ageing.

NOTE — Additives used in various oils can affect the performance of rubber and hence while selecting the polymer, compatibility with oil under application needs to be established.

10 SPECIFIC REQUIREMENTS FOR TYPE V

This type refers to gasket having good to excellent acid resistance. Basic polymer such as EPDM (ethylene propylene diene monomer) shall be used in their manufacture. The physical properties shall be as given in [Table 5](#).

Table 4B Physical Properties of Type IV Gaskets

(Clauses [4.2](#) and [9.2](#))

Sl No.	Physical Properties	Class	
		4C	4D
(1)	(2)	(3)	(4)
i)	Hardness (A), Shore A	70	80
ii)	Tensile strength, (kg/cm ²), <i>Min</i>	100	100
iii)	Elongation at break (percent), <i>Min</i>	175	150
iv)	Compression set (175 °C for 22 h), <i>Max</i>	35	35
v)	Accelerated ageing (200 °C for 70 h)		
a)	Change in hardness (A)		± 10
b)	Change in tensile strength (percent)		– 25
c)	Change in elongation at break (percent)		– 25
vi)	Ageing in oil no.1 (23 °C for 70 h)		
a)	Change in hardness (A)		±5
b)	Change in tensile strength (percent)		– 25
c)	Change in elongation at break (percent)		– 20
d)	Change in volume (percent)		0 to 10

Table 5 Physical Properties of Type V Gaskets

(Clauses [4.2](#) and [10](#))

Sl No.	Physical properties	Class		
		5A	5B	5C
(1)	(2)	(3)	(4)	(5)
i)	Hardness (A), Shore A	50 ± 5	60 ± 5	70 ± 5
ii)	Tensile strength, kg/cm ² , (<i>Min</i>)	70	100	100
iii)	Elongation at break (percent), <i>Min</i>	300	250	200
iv)	Compression set (150 °C for 22 h), <i>Max</i>	25	25	25
v)	accelerated ageing (150 °C for 70 h)			
a)	Change in hardness (A)		+ 10	
b)	Change in tensile strength (percent)		– 20	
c)	Change in elongation at break (percent)		– 20	
vi)	Water resistance (100 °C for 70 h)		± 5	

11 TEST METHODS

11.1 Hardness

Hardness of the gaskets shall be tested in accordance with the method prescribed in [Annex C](#).

11.2 Tensile Strength and Ultimate Elongation

Shall be carried out in accordance with method prescribed in IS 3400 (Part 1) using Type I dumbbell test piece.

11.3 Accelerated Ageing

The test pieces shall be subjected to this test in accordance with method prescribed in IS 3400 (Part 4).

11.4 Compression Set

Compression set shall be tested at $70\text{ }^{\circ}\text{C} \pm 1\text{ }^{\circ}\text{C}$ for 24 h under 25 percent strain according to the method prescribed in IS 3400 (Part 10/Sec 1). Recovery time of 60 min shall be allowed. *see* [Annex D](#).

11.5 Sample Thickness

For all types of gaskets, two test slabs, each of the following sizes shall be supplied:

- a) 2.5 mm (dumbbell shape); and
- b) 10 mm (button shape).

These slabs shall be compounded identically and cured to the same degree as the gaskets.

11.6 Unless otherwise agreed to between the purchaser and the supplier, all tests shall be carried out within 3 months from the receipt of the material by the purchaser.

PART II FOAM RUBBER GASKETS

12 FOAM RUBBER GASKETS

Foam rubber gasket is coming under special category of rubber gasket material mostly custom built to suit to the specific requirement of the buyer. Foam rubber gaskets are produced using the material foam rubber, which is manufactured with a foaming agent/blowing agents to create an air-filled matrix structure. Foam rubber for gaskets is generally made using either polyurethane foam rubber/silicone foam rubber/polychloroprene and natural rubber (either as closed cell or open cell structures). Foam rubber gaskets are coming in multiple grades and used to seal enclosures and devices. Material properties, compressibility, environmental exposure, sealing effectiveness and specifications should be

considered during the material selection.

13 TYPES OF FOAM RUBBER GASKETS

Foam rubber gaskets are of following four types:

- a) Strip;
- b) Die-cut;
- c) Form-in-place; and
- d) Bulb extrusion.

NOTE — Bulb extrusion help to seal according to the requirements of IS/IEC 60529.

14 MATERIAL

14.1 Polyurethane Foam Rubber Gaskets

Polyurethane foam gaskets are used in medical, industrial, and electronic packaging applications like medical filters, prosthetic devices, and healthcare facilities and laboratories, industrial, electrical and to protect electronic devices.

14.2 Silicone Foam Rubber Gaskets

Silicon foam rubber gaskets are used for high-temperature and low-temperature services and sanitary applications.

15 SEALING TEST

15.1 Gaskets are designed to seal many types of media, including water, air, dust, oil and others gasket material's sealing performance is tested using water as the medium of infiltration.

15.2 Hydro-test pressure applied will be 0.25 psi to 1 psi according to the application for a duration of about 30 min.

15.3 Equipment based on the design as Annex E of IS 17796 shall be used to carry out this sealing performance test of the foam rubber material used for this gasket.

15.4 Measurements/Findings

The leakage rate is measured as displacement in the column holding the pressurized water. The leakage is calculated in ml/min.

16 SAMPLING

Unless otherwise agreed to between the purchaser and the supplier, the procedure given in IS 2500 (Part 1) shall be followed. For this purpose, the inspection Level III and AQL value of 2.5 percent as per IS 2500 (Part 1) shall be taken.

17 MARKING

The following details shall be clearly marked on every gasket:

- a) Manufacturer's name and address;
- b) Type of gasket; and
- c) Date of manufacture.

17.1 BIS Certification Marking

The product(s) conforming to the requirements of this standard may be certified as per the conformity

assessment schemes under the provisions of the *Bureau of Indian Standards Act, 2016* and the Rules and Regulations framed thereunder, and the product(s) may be marked with the Standard Mark.

18 STORAGE

Recommendation regarding storage conditions after receipt from the manufacturer are given in IS 6713/ISO 2230.

ANNEX A

(Clause 2)

LIST OF REFERRED STANDARDS

<i>IS No.</i>	<i>Title</i>	<i>IS No.</i>	<i>Title</i>
IS 196 : 1966	Atmospheric conditions for testing (<i>revised</i>)		effect of liquids (<i>fourth revision</i>)
IS 2500 (Part 1) : 2000/ISO 2859-1 : 1999	Sampling procedure for inspection by attributes: Part 1 Sampling schemes indexed by acceptance quality limit (AQL) for lot-by-lot inspection (<i>third revision</i>)	IS 3400 (Part 10/ Sec 1) : 2020/ ISO 815-1 : 2014	Methods of test for vulcanized rubbers: Part 10 Compression set, Section 1 At ambient or elevated temperatures (<i>second revision</i>)
IS 3400 (Part 1) : 2021/ISO 37 : 2017	Methods of test for vulcanized rubber: Part 1 Tensile stress-strain properties (<i>fourth revision</i>)	IS 6713 : 2016/ ISO 2230 : 2002	Rubber products — Guidelines of storage (<i>second revision</i>)
IS 3400 (Part 4) : 2012/ISO 188 : 2011	Methods of test for vulcanized rubber: Part 4 Accelerated ageing and heat resistance (<i>third revision</i>)	IS 17796 : 2023	Gasket and packings — Compressed non-asbestos fibre (CNAF) based gasket jointing sheets — Specification
IS 3400 (Part 6) : 2018/ISO 1817 : 2015	Methods of test for vulcanized rubbers: Part 6 Determination of the	IS/IEC 60529 : 2001	Degrees of protection provided by enclosures (IP code)

To access Indian Standards click on the link below:

https://www.services.bis.gov.in/php/BIS_2.0/bisconnect/knowyourstandards/Indian_standards/isdetails/

ANNEX B(Clause [6.4](#))**WATER ABSORPTION TEST****B-1 PROCEDURE**

From the finished gasket, cut a piece of about 3 g and weigh it accurately. Put in 150 ml of distilled water. Boil under reflux with air condenser for 168 h. Remove the piece and weigh again after surface water layer is dried up with filter paper.

B-2 CALCULATION

Water absorption, percent by mass

$$= \frac{W_2 - W_1}{W_1} \times 100$$

where

w_2 = mass, in grams, of the test piece after immersion in water; and

w_1 = original mass, in grams, of test piece before immersion in water.

B-3 This test is not applicable for foam gaskets.

ANNEX C(Clause [11.1](#))**DETERMINATION OF HARDNESS SHORE A****C-1 APPARATUS**

- a) Presser foot with a hole between 2.5 mm and 3.2 mm in diameter, centered at least 6 mm from any edge of the foot;
- b) Indenter formed from hardened steel rod between 1.15 and 1.40 mm in diameter to the shape and dimensions as shown in [Fig. 1](#);
- c) Indenter extension indicating device (analog or electronic), having a scale reading from 0 to 100 with equal divisions throughout the range; for reading the extent of protrusion of the point of the indenter beyond the face of the presser foot; this may be read directly in terms of units ranging from zero, for full protrusion of 2.50 mm \pm 0.04 mm to 100, for nil protrusion obtained by placing the pressure foot and indenter in firm contact with a flat piece of glass. The scale reading is an inverse function of the indenter extension. The device shall have a pointer that moves on the scale at a rate of one hardness point for each 0.025 mm of indenter movement;
- d) Timing device (optional), capable of being set to a desired elapsed time, signaling the operator or holding the hardness reading when the desired elapsed time has been reached. The timer should be automatically activated when the presser foot is in firm contact with the specimen being tested; and
- e) Calibrated spring for applying force to the indenter in accordance with the following equation:

$$\text{Force, } N = 0.550 + 0.075 Hx$$
 where Hx is hardness reading on Type A durometer.

C-2 TEST PIECE

For the determination of hardness by Type A shore durometer, the test piece should be at least 6 mm thick and of convenient area, unless it is known that results equivalent to the 6 mm values are obtained with a thinner test piece. A test piece may be composed of plied thin pieces to obtain the necessary thickness, but determinations made on such test pieces may not agree with those made on one-piece solid test pieces because the surfaces between plies may not be in complete contact with each other. The dimensions of the test piece should be sufficient to permit measurements at least 12 mm away from any edge, unless it is known that identical results are obtained when measurements are made at a lesser distance from an edge. The surface of the test piece should be flat over an area sufficient to permit the presser foot to be in contact with the test piece over an area having a radius of at least 6 mm from the indenter point. Satisfactory hardness determinations cannot be made on rounded, uneven or rough surfaces.

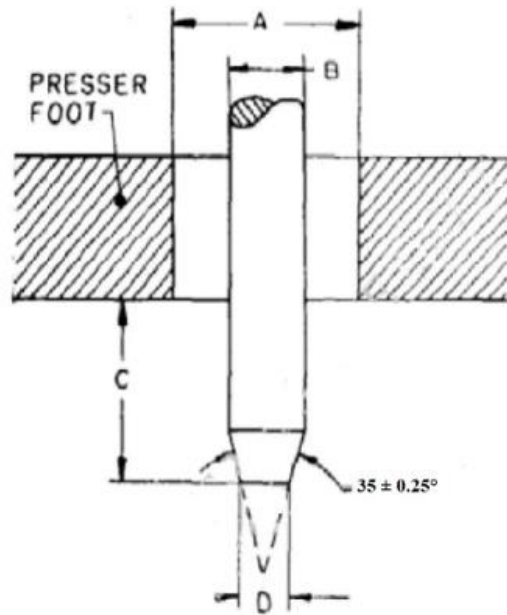

Key

- A = 2.5 to 3.2 mm
- B = 1.15 to 1.40 mm
- C = 2.5 ± 0.04 mm
- D = 0.79 ± 0.03 mm

FIG. 1 INDENTER FOR TYPE A DUROMETER

C-3 CALIBRATION

The durometer spring shall be calibrated by supporting the durometer in a vertical position and applying a measurable force to the indenter tip (see Fig. 2). The device used to apply the force may be a dead weight or electronic load cell device capable of measuring applied force at 50 percent of the calibration tolerance. Care should be taken to ensure that the force is applied vertically to the indenter tip, as side loads will cause errors in calibration. Spring calibration shall be verified for durometer at scale readings of 20, 30, 40, 50, 60, 70, 80 and 90. The measured force ($9.8 \times$ mass in kilograms) shall be equivalent to the force calculated by the equation 1. The measured force for type A durometer shall be within ± 0.08 N. Indenter shape and extension must be in accordance with C-1.

NOTE — Instruments specifically designed for calibration of durometers may be used. Test blocks (rubber or spring type) provided for checking durometer operation are not to be relied upon as calibration standards.

C-4 CONDITIONING OF TEST PIECE

Test shall be made at $27 \text{ }^\circ\text{C} \pm 2 \text{ }^\circ\text{C}$ and relative humidity of 65 percent ± 5 percent (see IS 196). Before testing the test pieces, the durometer and test pieces shall be conditioned at the

temperature and humidity of test for a minimum of 40 h for test pieces of 7 mm or under in thickness and for a minimum of 88 h for test pieces over 7 mm in thickness. Provide adequate air circulation on all sides of the test specimens by placing them in suitable racks, hanging them from metal clips or laying them on wide-mesh, wire screen frames with at least 25 mm between the screen and the surface of the bench. If, for any particular material or test, a specific longer time of conditioning is required, the time shall be agreed upon by the interested parties. Shorter conditioning times may be used for thin test pieces provided equilibrium is substantially reached.

C-5 PROCEDURE

Place the test piece on a hard horizontal, plane surface. Hold the durometer in a vertical position with the point of the indenter at least 12 mm from any edge of the test piece, unless it is known that identical results are obtained when measurements are made with the indenter at a lesser distance. Apply the presser foot to the test piece as rapidly as possible, without shock, keeping the foot parallel to the surface of the test piece. Apply just sufficient pressure to obtain firm contact between presser foot and test piece (see Notes). After the presser foot is in firm contact with the test piece, the scale reading is to be taken

within 1 s or after any period of time agreed upon between supplier and user unless the durometer has a maximum indicator, in which case the maximum reading is taken. The hardness reading may progressively decrease with time delay. Make one measurement at each of three or five different points distributed over the test piece at least 6 mm apart using the median of these measurements for the hardness value.

NOTES

1 This test is not applicable for foam gaskets.

2 Better reproducibility may be obtained by using a mass centered on the axis of the indenter. Recommended mass is 1 kg for the Type A durometer. Durometer stands using the masses above as a constant load and a controlled descent speed, without shock, produce maximum repeatability.

C-6 This test is not applicable for foam gaskets.

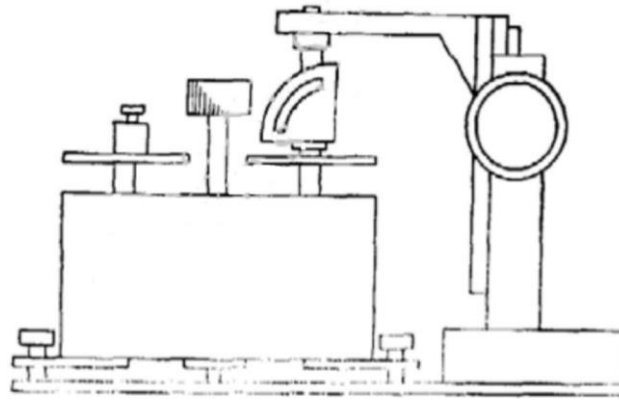

FIG. 2 APPARATUS FOR CALIBRATION OF DUROMETER SPRING

ANNEX D

(Clause [11.4](#))

COMPRESSION SET

D-1 CONTINUOUS COMPRESSION

Tests include tensile and elongation retention after exposure to 70 °C. Dimensional changes after oil immersion are also evaluated. This test is not applicable for foam gaskets.

D-2 PERIODIC RECOMPRESSION

In addition to continuous compression (above), a

compression set test is cycled at room temperature, 70 °C and – 30 °C. Impact testing is also performed at – 30 °C only.

D-3 This test is not applicable for foam gaskets.

ANNEX E

(Foreword)

COMMITTEE COMPOSITION

Gasket and Packing Sectional Committee, MED 30

<i>Organization</i>	<i>Representative(s)</i>
Engineers India Limited, New Delhi	SHRI U. CHAKRAVARTY (Chairperson)
Bharat Corrub Industries, Vadodara	SHRI B. M. TOLIA SHRI S. R. DESAI (<i>Alternate</i>)
Bharat Heavy Electricals Ltd, Delhi	SHRI SUBRATA RAY SHRI S. SUBBA (<i>Alternate I</i>) RAO SHRI R. ELAYARAJA (<i>Alternate II</i>)
Bharat Petroleum Corporation Ltd, Noida	SHRI S. MANIVANNAN
Champion Jointings Pvt Ltd, Mumbai	SHRI FARZAD J. PALIA SHRI MANOHAR S. DHANDEKAR (<i>Alternate</i>)
Crompton Greaves Ltd, Mumbai	SHRI P. S. RAMACHANDRAN
Defence Research and Development Organization, Research Centre Imarat, Hyderabad	SHRI A. K. MANDAL SHRI I. S. DAS (<i>Alternate</i>)
Department of Scientific and Industrial Research, New Delhi Directorate of Steam Boilers, Mumbai	SHRI PURUSHOTTAM KUMAR SHRI G. D. WANKHEDE SHRI S. S. SOLANKE (<i>Alternate</i>)
Engineers India Ltd, New Delhi	MOHAMMED ISMAEEL SHRI G. BALAJI (<i>Alternate I</i>) MS SULAKSHNA NAGNATH (<i>Alternate II</i>)
Ferolite Jointings Ltd, Ghaziabad	SHRI AKSHAY SHARMA SHRI PRADEEP KUMAR (<i>Alternate</i>)
GAIL (India) Ltd, New Delhi	SHRI NITIN NIMJE SHRI AMRESH BEDAR (<i>Alternate I</i>) SHRI ASHIF TADVI (<i>Alternate II</i>)
Hindustan Petroleum Corporation Ltd, Visakhapatnam	SHRI SANDIPTA NATH SHRI PRABHUDATTA PADARBINDA (<i>Alternate</i>)
ICAR - National Institute of Natural Fibre Engineering and Technology, Kolkata	DR SANJOY DEBNATH
I.G.P. Engineers Pvt Ltd, Chennai	SHRI G. GANESAN SHRI P. SUNDAR (<i>Alternate</i>)
Indian Sealing Association, New Delhi	SHRI RASIKLAL M. DOSHI SHRI DARSHAN A. PAREKH (<i>Alternate</i>)
Indian Valve and Actuator Manufacturers Association (IVAMA), Coimbatore L&T-Sargent & Lundy Limited, Vadodara	SHRI VISHAL WAKCHOURE SHRI R. MURUGANANTHAM (<i>Alternate</i>) SHRI MANISH V. SANE SHRI PINKESH PATEL (<i>Alternate</i>)

<i>Organization</i>	<i>Representative(s)</i>
Mecon Limited, Ranchi	SHRI GURNEK SINGH SHRI SUJOY BANERJEE (<i>Alternate</i>)
Ministry of Commerce and Industry, Department for Promotion of Industry and Internal Trade, New Delhi	SHRI SHAISH KUMAR SHRI M. Z. KHAN (<i>Alternate</i>)
Ministry of Science and Technology, Department of Science & Technology, New Delhi	SHRI PURUSHOTTAM KUMAR
NTPC Limited, Noida	SHRI U. K. MUKHOPADHYAY SHRI S. CHAKRABORTY (<i>Alternate</i>)
Nu-Cork Products Pvt Ltd, Gurugram	SHRI SWAPAN KUMAR DATTA
Ordnance Factory Board, Jabalpur	SHRI RAJNISH LODWAL SHRI M. K. MISHRA (<i>Alternate</i>)
Projects and Development India Ltd, Noida	SHRI HARISH KUMAR SHRI JITENDER KUMAR SINGH (<i>Alternate</i>)
RITES Ltd, Gurugram	SHRI PANKAJ AGARWAL SHRI MUKESH SINHA (<i>Alternate</i>)
Safe Water Network, New Delhi	SHRI PANKAJ AGARWAL SHRI MUKESH SINHA (<i>Alternate</i>)
Spareage Sealing Solution, Mumbai	SHRI SHIVA SHINDE
Super Waudite Jointing Pvt Ltd, Ahmedabad	SHRI PRADEEP J. PANDYA SHRI C. D. GAZDAR (<i>Alternate</i>)
Superlite Jointings Private Limited, Ghaziabad	SHRI VARUN AGARWAL SHRI PHERU SINGH (<i>Alternate</i>)
The Tata Power Company Ltd, Mumbai	SHRI DHIRAJ B. KAMATH SHRI V. V. NAMJOSHI (<i>Alternate</i>)
Uni Klinger Limited, Pune	SHRI MAHESH AVACHAT
BIS Directorate General	SHRI RAJNEESH KHOSLA, SCIENTIST 'F'/SENIOR DIRECTOR AND HEAD (MECHANICAL ENGINEERING) [REPRESENTING DIRECTOR GENERAL (<i>Ex-officio</i>)]

Member Secretary

MS KHUSHBU JYOTSNA KINDO
SCIENTIST 'C'/DEPUTY DIRECTOR
(MECHANICAL ENGINEERING), BIS

This Page has been Intentionally left blank

Bureau of Indian Standards

BIS is a statutory institution established under the *Bureau of Indian Standards Act, 2016* to promote harmonious development of the activities of standardization, marking and quality certification of goods and attending to connected matters in the country.

Copyright

BIS has the copyright of all its publications. No part of these publications may be reproduced in any form without the prior permission in writing of BIS. This does not preclude the free use, in the course of implementing the standard, of necessary details, such as symbols and sizes, type or grade designations. Enquiries relating to copyright be addressed to the Head (Publication & Sales), BIS.

Review of Indian Standards

Amendments are issued to standards as the need arises on the basis of comments. Standards are also reviewed periodically; a standard along with amendments is reaffirmed when such review indicates that no changes are needed; if the review indicates that changes are needed, it is taken up for revision. Users of Indian Standards should ascertain that they are in possession of the latest amendments or edition by referring to the website-www.bis.gov.in or www.standardsbis.in.

This Indian Standard has been developed from Doc No.: MED 30 (22221).

Amendments Issued Since Publication

Amend No.	Date of Issue	Text Affected

BUREAU OF INDIAN STANDARDS

Headquarters:

Manak Bhavan, 9 Bahadur Shah Zafar Marg, New Delhi 110002

Telephones: 2323 0131, 2323 3375, 2323 9402

Website: www.bis.gov.in

Regional Offices:

Central : 601/A, Konnectus Tower -1, 6th Floor,
DMRC Building, Bhavbhuti Marg, New
Delhi 110002

Telephones

{ 2323 7617

Eastern : 8th Floor, Plot No 7/7 & 7/8, CP Block, Sector V,
Salt Lake, Kolkata, West Bengal 700091

{ 2367 0012
{ 2320 9474

Northern : Plot No. 4-A, Sector 27-B, Madhya Marg,
Chandigarh 160019

{ 265 9930

Southern : C.I.T. Campus, IV Cross Road, Taramani, Chennai 600113

{ 2254 1442
{ 2254 1216

Western : 5th Floor/MTNL CETTM, Technology Street, Hiranandani Gardens,
Powai, Mumbai 400076

{ 2570 0030
{ 2570 2715

Branches : AHMEDABAD, BENGALURU, BHOPAL, BHUBANESHWAR, CHANDIGARH, CHENNAI, COIMBATORE, DEHRADUN, DELHI, FARIDABAD, GHAZIABAD, GUWAHATI, HARYANA (CHANDIGARH), HUBLI, HYDERABAD, JAIPUR, JAMMU, JAMSHEDPUR, KOCHI, KOLKATA, LUCKNOW, MADURAI, MUMBAI, NAGPUR, NOIDA, PARWANOO, PATNA, PUNE, RAIPUR, RAJKOT, SURAT, VIJAYAWADA.