

घरेलू सिलाई मशीनें — आर्म शाफ्ट —
विशिष्टि
(पहला पुनरीक्षण)

Household Sewing Machines — Arm
Shaft — Specification
(Second Revision)

ICS 61.080

© BIS 2024



भारतीय मानक ब्यूरो
BUREAU OF INDIAN STANDARDS
मानक भवन, 9 बहादुर शाह ज़फर मार्ग, नई दिल्ली - 110002
MANAK BHAVAN, 9 BAHADUR SHAH ZAFAR MARG
NEW DELHI - 110002
www.bis.gov.in www.standardsbis.in

FOREWORD

This Indian Standard (Second Revision) was adopted by the Bureau of Indian Standards, after the draft finalized by the Sewing Machine Sectional Committee had been approved by the Mechanical Engineering Division Council.

This standard was first published in 1966 and subsequently revised in 1991. This standard is being revised to keep pace with the latest technological developments and international practices. Also, in this revision, the standard has been brought into the latest style and format of Indian Standards, and references of Indian Standards, wherever applicable have been updated. BIS certification marking clause has been modified to align with the revised *Bureau of Indian Standards Act, 2016*. The major change in this revision is in the dimensions of the arm shaft such as diameter, length, width, taper, timing hole distance, timing hole angle, and pitch.

The composition of the Committee responsible for the formulation of this standard is given in [Annex B](#).

For the purpose of deciding whether a particular requirement of this standard is complied with the final value, observed or calculated, expressing the result of a test or analysis, shall be rounded off in accordance with IS 2 : 2022 'Rules for rounding off numerical values (*second revision*)'. The number of significant places retained in the rounded off value should be the same as that of the specified value in this standard.

*Indian Standard***HOUSEHOLD SEWING MACHINES — ARM SHAFT —
SPECIFICATION***(Second Revision)***1 SCOPE**

This standard specifies the requirements for arm shafts for sewing machines for household purposes.

2 REFERENCES

The standards given below contain provisions which, through reference in this text, constitute provision of this standard. At the time of publication, the editions indicated were valid. All standards are subject to revision, and parties to agreements based on this standard are encouraged to investigate the possibility of applying the most recent edition of these standards:

<i>IS No.</i>	<i>Title</i>
IS 1501 (Part 1) : 2020/ISO 6507- 1 : 2018	Metallic materials — Vickers hardness test: Part 1 Test method (<i>fifth revision</i>)
IS 2102 (Part 1) : 1993/ISO 2768- 1 : 1989	General tolerances: Part 1 Tolerances for linear and angular dimensions without individual tolerance indications (<i>third revision</i>)
IS 2500 (Part 1) : 2000/ISO 2859- 1 : 1999	Sampling procedures for inspection by attributes: Part 1 Sampling schemes indexed by acceptance quality limit (AQL) for lot-by-lot inspection (<i>third revision</i>)
IS 4905 : 2015/ ISO 24153 : 2009	Random sampling and randomization procedures (<i>first revision</i>)

3 TERMINOLOGY

The terminology of the arm shaft is shown in [Fig. 1](#).

4 TYPES

The arm shaft shall be of the following two types:

- a) Type A; and
- b) Type B.

5 MATERIAL

Suitable material shall be used for the manufacture of arm shaft.

6 HARDNESS

The bearing surfaces of the arm shaft shall be case hardened to attain a hardness value of minimum 500 HV [*see* IS 1501 (Part 1)].

7 DIMENSIONS AND TOLERANCES

7.1 The main dimensions for arm shafts shall be as given in [Fig. 2](#).

7.2 Tolerances on untoleranced dimensions shall be in accordance with medium class of IS 2102 (Part 1).

NOTE — The arm shafts may be supplied without thread take up timing screw hole, if so desired by the purchaser.

8 WORKMANSHIP AND FINISH

The arm shafts shall be well finished and free from any defects such as crack, burr, flaw, and rust.

9 MARKING

9.1 The arm shafts may be marked with the manufacturer's name or trademark.

9.2 BIS Certification Marking

The product(s) conforming to the requirements of this standard may be certified as per the conformity assessment schemes under the provisions of the *Bureau of Indian Standards Act, 2016* and the Rules and Regulations framed thereunder, and the product(s) may be marked with the Standard Mark.

10 PACKING

Each arm shaft shall be given a suitable antirust coating and wrapped in polyethylene bags. The wrapped arm shaft shall be securely packed in accordance with the best prevalent trade practice. Each package shall bear indication of the source of manufacture, type and description of contents.

11 SAMPLING

Unless otherwise agreed to between the purchaser and the supplier the sampling plan as given in [Annex A](#) shall be followed. For further information, reference may be made to IS 2500 (Part 1).

To access Indian Standards click on the link below:

https://www.services.bis.gov.in/php/BIS_2.0/bisconnect/knowyourstandards/Indian_standards/isdetails/

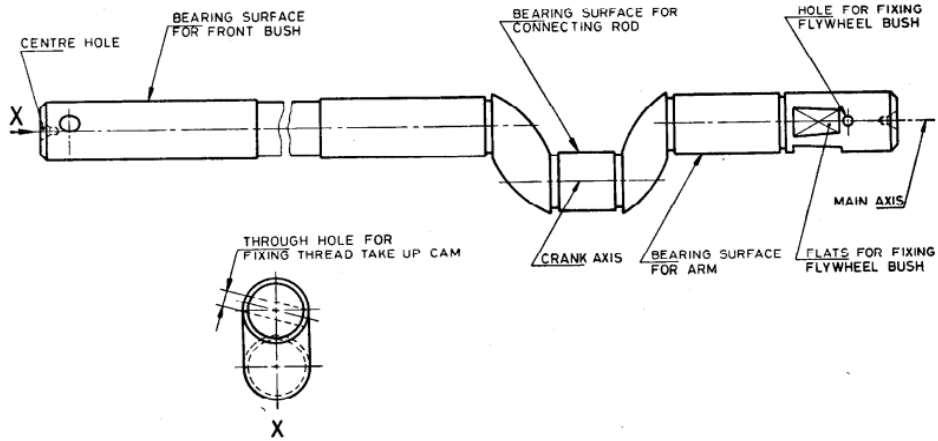
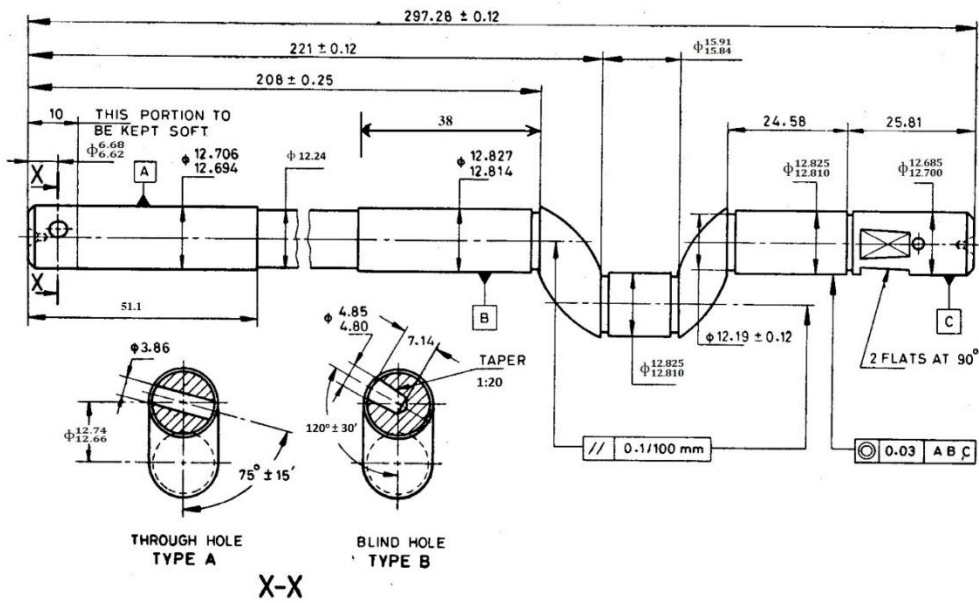

FIG. 1 TERMINOLOGY FOR ARM SHAFT



Sl No.	Item	Type A	Type B
(1)	(2)	(3)	(4)
i)	Hole for fixing thread take-up cam	Through taper hole for taper dowel pin (drilled in assembly)	Taper hole for screw
ii)	Fixing of fly wheel bush	Two flats at right angles	Through taper hole for taper dowel pin (drilled in assembly)

All dimensions in millimetres.

FIG. 2 DIMENSIONS FOR ARM SHAFT

ANNEX A

(Clause 11)

SCALE OF SAMPLING AND CRITERIA FOR CONFORMITY

A-1 SCALE OF SAMPLING

A-1.1 Lot

In any consignment, all the arm shafts of the same type and manufactured from the same material under essentially similar conditions of manufacture shall be grouped together to constitute a lot.

A-1.2 For ascertaining the conformity of the lot to the requirements of the specification, tests shall be carried out for each lot separately. The number of arm shafts to be selected at random for this purpose shall be in accordance with col (2) and col (3) of [Table 1](#).

A-1.3 If the arm shafts are packed individually in order to ensure the randomness of selection, IS 4905 shall be used.

A-1.4 If the arm shafts are packed in different cartons, a suitable number of cartons (not less than 20 percent of the total in the lot subject to a minimum of 2) shall be chosen, at random. From each of the cartons so chosen an approximately equal number of arm shafts shall be picked up from its different parts so as to obtain the required number

of arm shafts specified in col (3) of [Table 1](#).

A-2 NUMBER OF TESTS AND CRITERIA FOR CONFORMITY

A-2.1 The arm shafts selected according to [A-1.2](#) and [A-1.3](#) or [A-1.4](#) shall be examined for dimensions and tolerances (*see* [7](#)) and workmanship and finish (*see* [8](#)). If the number of arm shaft failing to meet one or more of the requirements mentioned above is less than or equal to the permissible number of defectives given in col (4) of the [Table 1](#), the lot shall be declared as conforming to the requirements of these characteristics.

A-2.2 In case of those lots which have been found satisfactory according to [A-2.1](#), a number of arm shafts equal to the sample size indicated in col (5) of [Table 1](#), shall be subjected to hardness test (*see* [6](#)). Any arm shaft failing to meet the requirement for hardness shall be considered to be defective.

If no defectives are found among the arm shafts subjected to the hardness test (*see* [A-2.2](#)), the lot shall be declared as conforming to the requirements of the specification, otherwise not.

Table 1 Scale of Sampling and Permissible Number of Defectives

(Clauses [A-1.2](#), [A-1.4](#), [A-2.1](#) and [A-2.2](#))

Sl No.	No. of Arm Shafts in the Lot	For Dimensions, Tolerances, Workmanship, Finish and Test		
		Sample Size n	Permissible No. of Defectives ¹⁾	Sample Size for Hardness
(1)	(2)	(3)	(4)	(5)
i)	Up to 15	5	0	2
ii)	16 to 40	8	0	3
iii)	41 to 110	13	0	3
iv)	111 to 300	20	1	5
v)	301 to 500	32	1	6
vi)	501 to 800	50	2	8
vii)	801 to 1 300	80	3	10
viii)	1 301 and above	125	5	15

¹⁾This ensures that lots containing one and half percent or less defective will be accepted most of the time

ANNEX B

(Foreword)

COMMITTEE COMPOSITION

Sewing Machines Sectional Committee, MED 29

<i>Organization</i>	<i>Representative (s)</i>
Research & Development Centre for Bicycle and Sewing Machines, Ludhiana	SHRI RAKESH PATHAK (<i>Chairperson</i>)
Brother International (India) Private Limited, Mumbai	SHRI MATHEW YOHANNAN
C.R. Auluck & Sons Private Limited, Ludhiana	SHRI SUNIL AULUCK SHRI KULJEET SINGH (<i>Alternate</i>)
Directorate General of Quality Assurance, New Delhi	SHRI R. V. JAIN
G.D. Rupal Industries, Ludhiana	SHRI GURMUKH SINGH
Gee Tech Hooks, Ludhiana	SHRI MANJEET SINGH
Geminy Industrial Enterprises Private Limited, Ludhiana	SHRI VINAY DUA SHRI B. C. PANDEY (<i>Alternate</i>)
Ludhiana Sewing Machine Association, Ludhiana	SHRI HARDEEP SINGH SHRI RAJVINDER (<i>Alternate</i>)
Makhan Sewing Machines, Ludhiana	SHRI DALBIR SINGH DHIMAN
Mechanical Engineering Research and Development Organization (MERADO) , Ludhiana	SHRI SYED SALMAN MOJIZ SHRI BHAGWANT SINGH LAL (<i>Alternate</i>)
Narindera & Company, Ludhiana	SHRI S. BALDEV SINGH SHRI HARINDER JIT SINGH (<i>Alternate</i>)
Navrang Manufacturing Corporation, Ludhiana	SHRI DINESH KAPILA SHRI SUDESH KAPILA (<i>Alternate</i>)
Northern India Textile Research Association, Ghaziabad	SHRI VIKAS SHARMA SHRI VIVEK AGARWAL (<i>Alternate</i>)
Novel Sewing Machine Technologies, Pune	SHRI BHARAT NARAYENDAS PARMAR SHRI ARJUN BHARAT PARMAR (<i>Alternate</i>)
ORAA International, Ludhiana	SHRI ASHISH GUPTA
Office of Development Commissioner (MSME), New Delhi	SHRI SUVANKAR SANTRA MS MAITREYEE TALAPATRA (<i>Alternate</i>)
Research & Development Centre for Bicycle and Sewing Machines, Ludhiana	SHRI VISHWAS MEHTA SHRI SURIENDER PAL SINGH (<i>Alternate</i>)
Ranew Engineering (India) Private Limited, Ludhiana	SHRI SANJEEV KUMAR JAIN SHRI ABHILASH JAIN (<i>Alternate</i>)
Rita Machines India Private Limited, Ludhiana	SHRI SUNIL K. JAIN SHRI JAGDISH CHANDRA AULUCK (<i>Alternate</i>)
Singer India Limited, New Delhi	SHRI PRASHANT AGGARWAL SHRI ATUL KUMAR SETH (<i>Alternate</i>)
Swan Mechanical Works, Ludhiana	SHRI AMARJIT SINGH

<i>Organization</i>	<i>Representative (s)</i>
United Sewing Machines and Parts Manufacturing Association, Ludhiana	SHRI DALBIR SINGH DHIMAN
Usha International Limited, New Delhi	SHRI RUP LAL KANGLA SHRI PRANAY SRIWASTAV (<i>Alternate</i>)
Uttam Sewing Machine Company (Private) Limited, Jalandhar	SHRI JAGDEEP RAI SHRI MANOHAR LAL (<i>Alternate</i>)
Virindra Engineering Works, Ludhiana	SHRI AMANPREET SINGH SHRI SWARN SINGH (<i>Alternate</i>)
Voluntary Organisation in Interest of Consumer Education (VOICE), New Delhi	SHRI . M. A. U. KHAN
BIS Directorate General	SHRI K. VENKATESWARA RAO, SCIENTIST 'F'/ SENIOR DIRECTOR AND HEAD (MECHANICAL ENGINEERING) [REPRESENTING DIRECTOR GENERAL (<i>Ex-officio</i>)]

Member Secretary

SHRI SHUBHAM TIWARI
SCIENTIST 'C'/DEPUTY DIRECTOR
(MECHANICAL ENGINEERING), BIS

Bureau of Indian Standards

BIS is a statutory institution established under the *Bureau of Indian Standards Act, 2016* to promote harmonious development of the activities of standardization, marking and quality certification of goods and attending to connected matters in the country.

Copyright

BIS has the copyright of all its publications. No part of these publications may be reproduced in any form without the prior permission in writing of BIS. This does not preclude the free use, in the course of implementing the standard, of necessary details, such as symbols and sizes, type or grade designations. Enquiries relating to copyright be addressed to the Head (Publication & Sales), BIS.

Review of Indian Standards

Amendments are issued to standards as the need arises on the basis of comments. Standards are also reviewed periodically; a standard along with amendments is reaffirmed when such review indicates that no changes are needed; if the review indicates that changes are needed, it is taken up for revision. Users of Indian Standards should ascertain that they are in possession of the latest amendments or edition by referring to the website-www.bis.gov.in or www.standardsbis.in.

This Indian Standard has been developed from Doc No.: MED 29 (19877).

Amendments Issued Since Publication

Amend No.	Date of Issue	Text Affected

BUREAU OF INDIAN STANDARDS

Headquarters:

Manak Bhavan, 9 Bahadur Shah Zafar Marg, New Delhi 110002

Telephones: 2323 0131, 2323 3375, 2323 9402

Website: www.bis.gov.in

Regional Offices:

	Telephones
Central : 601/A, Konnectus Tower -1, 6 th Floor, DMRC Building, Bhavbhuti Marg, New Delhi 110002	{ 2323 7617
Eastern : 8 th Floor, Plot No 7/7 & 7/8, CP Block, Sector V, Salt Lake, Kolkata, West Bengal 700091	{ 2367 0012 2320 9474
Northern : Plot No. 4-A, Sector 27-B, Madhya Marg, Chandigarh 160019	{ 265 9930
Southern : C.I.T. Campus, IV Cross Road, Taramani, Chennai 600113	{ 2254 1442 2254 1216
Western : Manakalya, 5 th Floor/MTNL CETTM, Technology Street, Hiranandani Gardens, Powai Mumbai 400076	{ 25700030 25702715

Branches : AHMEDABAD, BENGALURU, BHOPAL, BHUBANESHWAR, CHANDIGARH, CHENNAI, COIMBATORE, DEHRADUN, DELHI, FARIDABAD, GHAZIABAD, GUWAHATI, HARYANA (CHANDIGARH), HUBLI, HYDERABAD, JAIPUR, JAMMU, JAMSHEDPUR, KOCHI, KOLKATA, LUCKNOW, MADURAI, MUMBAI, NAGPUR, NOIDA, PARWANOO, PATNA, PUNE, RAIPUR, RAJKOT, SURAT, VIJAYAWADA.