

AMENDMENT NO. 2 NOVEMBER 2024

TO

IS 16988 : 2018 COMPRESSED NATURAL GAS CYLINDER VALVE INTEGRATED WITH SOLENOID OPERATION (REMOTELY CONTROLLED) FOR AUTOMOTIVE USE — SPECIFICATION

(Page 5, clause 7.2.1) — Substitute the following for existing:

‘Where the pressure relief device is a bursting disc fitted to the valves of CNG cylinders, the maximum bursting pressure shall not exceed the 110 percent of test pressure of the cylinder and shall be more than the developed pressure of gas at 65 °C. The rated bursting pressure shall meet the requirement as mentioned above and same shall be specified in drawing. The actual burst pressure of the disc shall not be in excess of its rated burst pressure and not less than 90 percent of its rated burst pressure.’

(Page 13, clause 9.1.1, Note) — Insert the following note at the end and number the previous note as 1:

‘2 Outlet connection for CNG valves shall be subjected to agreement between the purchaser and the manufacturer.’

(Page 14, Outlet No. 21A) — Substitute the existing 'ENLARGED DETAIL AT X' by the following 'ENLARGED DETAIL AT X':

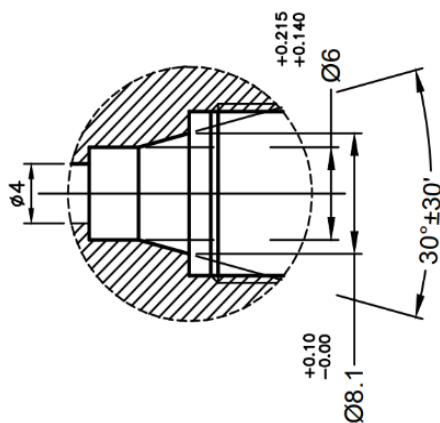

ENLARGE DETAIL OF X

Kindly change highlighted to "AT"

(Page 16, clause 10, para 6) — Insert the following at the end:

‘(n) Changes of the O-ring material of a valve parallel inlet connection (repetition of impact test).’

(Page 23, clause 11.1.5) — Delete the clause and its sub clause.

(Page 24, clause 11.1.7, para 1) — Delete ‘and condensate corrosion resistance test (see 11.1.5)’.

(Page 24, clause 11.1.8.2.3, line 2) — Delete ‘and condensate corrosion resistance test (see 11.1.5)’.

(Page 24, clause 11.1.8.3.2, line 2) — Delete ‘and condensate corrosion resistance test (see 11.1.5)’.

(Page 24, clause 11.1.8.4.2, line 2) — Delete ‘and condensate corrosion resistance test (see 11.1.5)’.

(MED 16)

Price Group 1

Publication, BIS, New Delhi