

मुख्यतः कोयले में वेधन करने हेतु घूर्णी वेध
बिट्स — विशिष्टि
(दूसरा पुनरीक्षण)

**Rotary Drill Bits for Drilling
Principally in Coal — Specification**
(*Second Revision*)

ICS 73.020

© BIS 2024



भारतीय मानक ब्यूरो
BUREAU OF INDIAN STANDARDS
मानक भवन, 9 बहादुर शाह ज़फर मार्ग, नई दिल्ली - 110002
MANAK BHAVAN, 9 BAHADUR SHAH ZAFAR MARG
NEW DELHI - 110002

www.bis.gov.in www.standardsbis.in

FOREWORD

This Indian Standard (Second Revision) was adopted by the Bureau of Indian Standards after the draft finalized by the Mining Techniques and Equipment Sectional Committee had been approved by the Mechanical Engineering Divisional Council.

This standard was first published in 1976 and then subsequently revised in 1988. This revision has been brought out with a view to incorporate the modification found necessary as a result of experience gained in the use of this standard. Also, in this revision, the standard has been brought into the latest style and format of Indian Standards, and references to Indian Standards, wherever applicable have been updated. BIS certification marking clause has been modified to align with the revised *Bureau of Indian Standard Act*, 2016. The following major modifications have been incorporated in this revision of the standard.

- a) A reference clause has been added mentioning the latest version of all the referred standards.

The composition of the Committee responsible for the formulation of this standard is given in [Annex A](#).

For the purpose of deciding whether a particular requirement of this standard is complied with, the final value, observed or calculated, expressing the result of a test or analysis, shall be rounded off in accordance with IS 2 : 2022 'Rules for rounding off numerical values (*second revision*)'. The number of significant places retained in the rounded-off value should be the same as that of the specified value in this standard.

*Indian Standard***ROTARY DRILL BITS FOR DRILLING PRINCIPALLY IN
COAL — SPECIFICATION***(Second Revision)***1 SCOPE**

1.1 This standard covers the requirements for rotary drill bits used for drilling holes. The tools are principally for use in coal but are applicable to other materials having appropriate driving characteristics.

1.2 This standard also covers the pilot and reamer bits for drilling large diameter holes.

2 REFERENCES

The standard given below contains provisions which, through reference in this text, constitute provision of this standard. At the time of publication, the edition indicated was valid. All standards are subject to revision, and parties to agreements based on this standard are encouraged to investigate the possibility of applying the most recent edition of this standard.

<i>IS No.</i>	<i>Title</i>
IS 4005 : 1967	Specification for tungsten carbide for mining tools

3 TYPES

- a) Type A — One piece bits; and
- b) Type B — Two piece bits consisting of pilot and reamer bits.

4 NOMINAL SIZES

<i>Sl No.</i>	<i>Type A</i>	<i>Type B</i>	
		<i>Pilot</i>	<i>Reamer</i>
(1)	(2)	(3)	(4)
i)	35	35	63
ii)	38	43	75
iii)	43	-	-
iv)	52	-	-

5 DIMENSIONS**5.1 Shanks** (See Fig. 1)

To access Indian Standards click on the link below:

https://www.services.bis.gov.in/php/BIS_2.0/bisconnect/knowyourstandards/Indian_standards/isdetails/

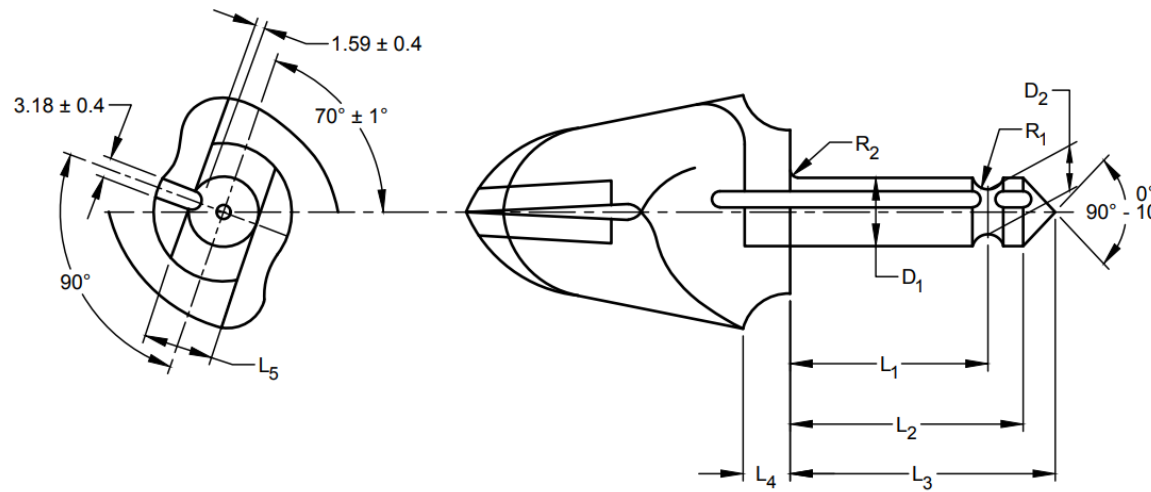

Please add following:
Fig. 1 Shanks

All dimensions in millimetres.

<i>Sl No.</i>	<i>Type of Bit</i>	D_1	D_2	L_1	L_2	L_3	L_4	L_5	R_1	R_2
		0 - 0.10	0 - 0.25	+ 0.15 0	± 0.4	<i>Max</i>	± 0.3	0 - 0.33	± 0.13	<i>Max</i>
(1)	(2)	(3)	(4)	(5)	(6)	(7)	(8)	(9)	(10)	(11)
i)	A	12.7	8.6	23.0	29.9	39.3	9.7	13.1	3.2	0.3
ii)	B	12.7	8.6	40.5	47.4	57.2	9.7	13.1	3.2	0.3

5.2 Body

5.2.1 Type A Bits and Pilot Bits for Type B Bits (See Fig. 2)

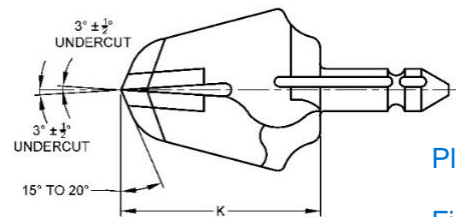
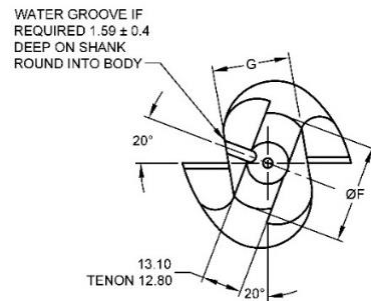
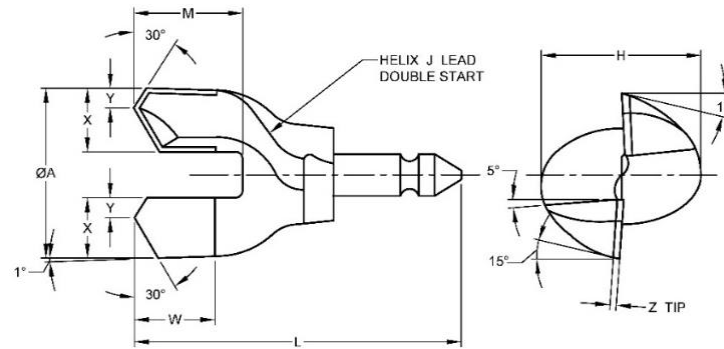

Please add following:

Fig. 2 Body - Typa A Bits and Pilot Bits for Type B Bits

All dimensions in millimetres.

Sl No.	Nominal Size	Cutting Diameter A +0.76 0	Tip Width X	Tip Chamfer Y	Tip Height W	Tip Thickness Z Min	Tenon Diameter F	Body Width G	Core Width H	Lead J	Body length K	Overall Length L		Gap Height M
												Type A	Type B	
(1)	(2)	(3)	(4)	(5)	(6)	(7)	(8)	(9)	(10)	(11)	(12)	(13)	(14)	(15)
i)	35	35	14	4	19	3	20	22	32	64	52	91.3	109.2	24
ii)	38	38	14	4	19	3	21	19	32	76	52	91.3	—	27
iii)	43	43	16	4	24	3	22	22	40	76	56	95.3	113.2	30
iv)	52	52	19	6	25	4	29	24	49	127	60	99.3	—	32

5.2.2 Reamer Bits for Type B Bits (See Fig 3)

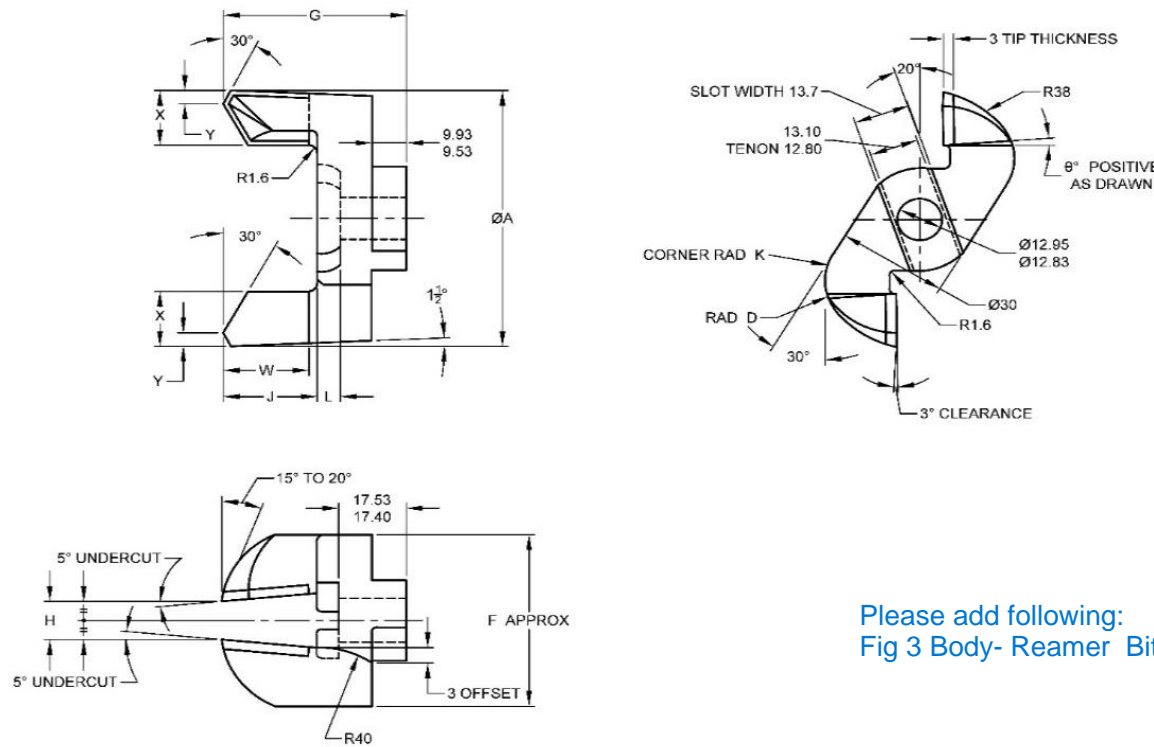

Please add following:
Fig 3 Body- Reamer Bits for Type B Bits

All dimensions in millimetres.

Sl No.	Nominal Size	Cutting Dia. A +0.51 0	Tip Width X	Tip Chamfer Y	Heal Radius D	Tip Length W	Bit Width F	Bit Height G	Gap Width H	Gas Height J	Corner Radius K	Slot Depth L	Clearance Angle θ
(1)	(2)	(3)	(4)	(5)	(6)	(7)	(8)	(9)	(10)	(11)	(12)	(13)	(14)
i)	63	63	14	4	10	19	48	51	9	25	3	9	15° NEG
ii)	75	75	16	4	16	24	51	51	11	25	6	6	3° POS

6 MATERIAL

- a) Shank and body — High tensile steel with 0.55 percent carbon, *Min*; and
- b) Tips — Tungsten carbide conforming to IS 4005. Grade used shall be at the option of the purchaser.

7 DESIGNATION

A rotary drill bit of Type A, nominal size 38 and having tip of H grade of tungsten carbide shall be designated as:

Rotary Drill Bit A38H

8 HARDNESS

210 HV, *Min* for bit bodies.

9 GENERAL REQUIREMENTS

9.1 The bit body shall allow an unrestricted flow of cuttings away from the bit when the latter is fitted into the rod.

9.2 The attachment of the bit to the drill rod shall be streamlined to give unobstructed flow of the cuttings.

9.2 The tips shall be firmly brazed to the body of the bits.

9.3 Rotary drill bits shall be supplied with or without

water grooves as specified by the purchaser.

9.4 Rotary drill bit shall have rake angle normally of + 3°. However, if required by the purchaser, rotary drill bit with 0 to - 4° rake angle may be supplied.

10 IDENTIFICATION

Except for the shank, the bits shall be painted with the colour appropriate to the grade of tungsten carbide used in the manufacture of the tip (*see* IS 4005).

11 MARKING

Each rotary drill bit shall be marked on the driving flats with the following:

- a) Manufacturer's name or trademark;
- b) Letter H, M, T or XT to identify the grade of tungsten carbide; and
- c) Nominal size.

11.1 BIS Certification Marking

The product(s) conforming to the requirements of this standard may be certified as per the conformity assessment schemes under the provisions of the *Bureau of Indian Standards Act, 2016* and the Rules and Regulations framed thereunder, and the products may be marked with the Standard Mark.

Your
suggestion
is found
in order



ANNEX A

(Foreword)

COMMITTEE COMPOSITION

Mining Techniques and Equipment Sectional Committee, MED 08

<i>Organization</i>	<i>Representative(s)</i>
Directorate General of Mines Safety, Dhanbad	SHRI SAIFULLAH ANSARI (<i>Chairperson</i>)
Automotive Research Association of India, Pune	SHRI MILIND KANDALKAR SHRI DHONDIRAM MOLE (<i>Alternate</i>)
BEML Limited, Bengaluru	SHRI V. R. S. PRASAD RAO SHRI H. G. SURESH (<i>Alternate</i>)
CSIR - Central Institute for Mining and Fuel Research, Dhanbad	DR MANOJ KUMAR SINGH SHRI SURAJIT DEY (<i>Alternate I</i>) PROF S. K. KASHYAP (<i>Alternate II</i>)
Directorate General of Mines Safety, Dhanbad	SHRI M. ARUMUGAM
Eastern Coalfields Limited, Dishergarh	SHRI SARVESH KUMAR SHRI AJAY BHOWMIK (<i>Alternate</i>)
Eimco Elecon (India) Limited, Vallabh Vidyanagar	SHRI RAM RAMESH KALE SHRI VINAY JAYNARAYAN SHARMA (<i>Alternate</i>)
Hutti Gold Mines Company Limited, Bengaluru	DR PRABHAKAR SANGOORMATH SHRI MALLIKARJUN SARAPUR (<i>Alternate I</i>) MS MEGA HIREMATH (<i>Alternate II</i>)
Indian Institute of Technology (ISM), Dhanbad	SHRI L. A. KUMARASWAMIDHAS
Manganese Ore Limited, Nagpur	SHRI RAKESH KUMAR VERMA SHRI ATUL SHARMA (<i>Alternate I</i>) SHRI ASHWINI BAGHELE (<i>Alternate II</i>)
Metso Outotec India Private Limited, Vadodara	SHRI SANDEEP DEOKISAN BHATTAD
Nanda Millar Company, Kolkata	SHRI J. P. GOENKA SHRI MADHUR GOENKA (<i>Alternate</i>)
Tata Steel Limited, Dhanbad	SHRI SOUMENDHU MANJHI SHRI ABINASH JHA (<i>Alternate</i>)
BIS Directorate General	SHRI K. VENKATESWARA RAO, SCIENTIST 'F'/ SENIOR DIRECTOR AND HEAD (MECHANICAL ENGINEERING) [REPRESENTING DIRECTOR GENERAL (<i>Ex-officio</i>)]

Member Secretary

SHRI SHUBHAM TIWARI
SCIENTIST 'C'/DEPUTY DIRECTOR
(MECHANICAL ENGINEERING), BIS

Bureau of Indian Standards

BIS is a statutory institution established under the *Bureau of Indian Standards Act, 2016* to promote harmonious development of the activities of standardization, marking and quality certification of goods and attending to connected matters in the country.

Copyright

BIS has the copyright of all its publications. No part of these publications may be reproduced in any form without the prior permission in writing of BIS. This does not preclude the free use, in the course of implementing the standard, of necessary details, such as symbols and sizes, type or grade designations. Enquiries relating to copyright be addressed to the Head (Publication & Sales), BIS.

Review of Indian Standards

Amendments are issued to standards as the need arises on the basis of comments. Standards are also reviewed periodically; a standard along with amendments is reaffirmed when such review indicates that no changes are needed; if the review indicates that changes are needed, it is taken up for revision. Users of Indian Standards should ascertain that they are in possession of the latest amendments or edition by referring to the website-www.bis.gov.in or www.standardsbis.in.

This Indian Standard has been developed from Doc No.: MED 08 (21735).

Amendments Issued Since Publication

Amend No.	Date of Issue	Text Affected

BUREAU OF INDIAN STANDARDS

Headquarters:

Manak Bhavan, 9 Bahadur Shah Zafar Marg, New Delhi 110002

Telephones: 2323 0131, 2323 3375, 2323 9402

Website: www.bis.gov.in

Regional Offices:

Central : 601/A, Konnectus Tower -1, 6th Floor,
DMRC Building, Bhavbhuti Marg, New
Delhi 110002

Telephones

{ 2323 7617

Eastern : 8th Floor, Plot No 7/7 & 7/8, CP Block, Sector V,
Salt Lake, Kolkata, West Bengal 700091

{ 2367 0012
2320 9474

Northern : Plot No. 4-A, Sector 27-B, Madhya Marg,
Chandigarh 160019

{ 265 9930

Southern : C.I.T. Campus, IV Cross Road, Taramani, Chennai 600113

{ 2254 1442
2254 1216

Western : 5th Floor/MTNL CETTM, Technology Street, Hiranandani Gardens, Powai
Mumbai 400076

{ 25700030
25702715

Branches : AHMEDABAD, BENGALURU, BHOPAL, BHUBANESHWAR, CHANDIGARH, CHENNAI, COIMBATORE, DEHRADUN, DELHI, FARIDABAD, GHAZIABAD, GUWAHATI, HARYANA (CHANDIGARH), HUBLI, HYDERABAD, JAIPUR, JAMMU, JAMSHEDPUR, KOCHI, KOLKATA, LUCKNOW, MADURAI, MUMBAI, NAGPUR, NOIDA, PARWANOO, PATNA, PUNE, RAIPUR, RAJKOT, SURAT, VIJAYAWADA.