सौर तापन — पानी गर्म करने की घरेलू
परणाली

भाग 3 कॉम्पोनेन्ट परफॉरमेंस डेटा के आधार
पर सिस्टम कॉम्पोनेन्ट अभिलक्षण तथा
वार्षिक परफॉरमेंस पूर्वानुमान के लिए विधि
(पहला पुनरीक्षण)

**Solar Heating — Domestic Water
Heating Systems**

**Part 3 Procedures for System
Component Characterization and
Predication for Yearly Performance
Using Component Performance Data**

(*First Revision*)

ICS 27.160

© BIS 2024



भारतीय मानक ब्यूरो
BUREAU OF INDIAN STANDARDS
मानक भवन, 9 बहादुर शाह ज़फर मार्ग, नई दिल्ली - 110002
MANAK BHAVAN, 9 BAHADUR SHAH ZAFAR MARG
NEW DELHI - 110002

www.bis.gov.in www.standardsbis.in

FOREWORD

This Indian Standard (Part 3) (First Revision) was adopted by the Bureau of Indian Standards, after the draft finalized by the Renewable Energy Sources Sectional Committee had been approved by the Mechanical Engineering Division Council.

This standard was first published in 1991. A wide variety of solar domestic hot water (SDHW) systems are marketed throughout the world. A natural consequence of this highly dispersed activity is the need to understand, predict and compare the performance of these systems. Standardized test methods are essential for assessing the performance potential. This standard has been developed to facilitate the comparison of these systems.

Because of the various testing methodologies for determining thermal performance are being followed and acceptance in the industry, it was decided to prepare separate parts of this standard each covering a separate methodology.

This standard describes two different test procedures to determine the necessary system parameters for a specific system to be used in the computer model of the system which is to be tested.

The described test method is developed for domestic hot water system (DHWS) for typical single family houses, where the system can be tested in the laboratory, but in principle much bigger system can be treated in the same way when the system for practical reasons are to be *in-situ*. The method is only restricted to be systems where it is not possible to establish verified models of the function of the systems.

This revision has been taken up to keep pace with the latest technological developments. In this revision, the standard has been brought into latest style and format of Indian Standards, and references to Indian Standards, wherever applicable have been updated.

Other parts of the standard under the general title ‘Solar heating — domestic water heating system’ are:

- Part 1 Performance rating procedure using indoor test methods;
- Part 2 Procedure for system performance characterization and yearly performance prediction; and
- Part 4 Test methods to determine durability and reliability.

The composition of the Committee responsible for the formulation of this standard is given in [Annex F](#).

For the purpose of deciding whether a particular requirement of this standard is complied with, the final value, observed or calculated, expressing the result of a test or analysis, shall be rounded off in accordance with IS 2 : 2022 ‘Rules for rounding off numerical values (*second revision*)’. The number of significant places retained in the rounded off value should be the same as that of the specified value in this standard.

*Indian Standard***SOLAR HEATING — DOMESTIC WATER HEATING SYSTEMS****PART 3 PROCEDURES FOR SYSTEM COMPONENT CHARACTERIZATION AND PREDICATION FOR YEARLY PERFORMANCE USING COMPONENT PERFORMANCE DATA***(First Revision)***1 SCOPE**

This standard (Part 3) specifies a method for predication of the long-term yearly performance of solar water heaters based on detailed simulation of the system. The standard specifies two approaches to characterize the necessary system parameters for the simulation, either by separate component testing or by a certain computer simulation programme, but well-established detailed national programmes are to be used for this purpose.

2 REFERENCES

The standards given below contain provisions which, through reference in this text, constitute provisions of this standard. At the time of publication, the edition indicated were valid. All standards are subject to revision and parties to agreements based on this standard are encouraged to investigate the possibility of applying the most recent edition of these standards:

<i>IS No.</i>	<i>Title</i>
IS 12933	Solar flat plate collector — Specification:
(Part 1) : 2003	Requirements (<i>second revision</i>)
(Part 2) : 2003	Components (<i>second revision</i>)
(Part 3) : 2003	Measuring instruments (<i>first revision</i>)
(Part 5) : 2003	Test methods (<i>second revision</i>)

3 DEFINITIONS**3.1 Solar Domestic Hot Water Systems**

3.1.1 Solar Hot Water System — A solar hot water system is the complete assembly of sub-systems and components necessary to convert solar irradiation into thermal energy for the heating of water. The system may include an auxiliary heat source.

3.1.2 Domestic — Domestic refers to use in residential and small commercial buildings.

3.1.3 Direct System — In a direct system the water that will ultimately be drawn from the hot taps passes through the collector.

3.1.4 Indirect System — In an indirect system; a fluid other than the water ultimately drawn from the hot tap passes through the collector.

3.1.5 Forced Circulation — In a forced circulation (pumped) system, the heat transfer fluid is circulated by means of a pump.

3.1.6 Thermosiphon System — In a thermosiphon system, circulation of the heat transfer fluid is achieved by natural convection.

3.1.7 Integral Collector Storage System — In integral collector storage (ICS) system, the functions of collecting solar energy storing energy thermal energy are performed within the same device.

3.1.8 Remote Storage System — In a remote storage system the storage vessel is separate from the collector and located at a distance from it.

3.1.9 Close-Coupled Collector and Storage System — In a close-coupled collector and storage system, the storage vessel is situated next to the collector, and is mounted on a common support frame.

3.2 Components

3.2.1 Solar Collector — A solar collector is a device which absorbs solar radiation, converts it into heat and passes this heat on to a heat transfer fluid.

3.2.2 Aperture Area of Collector (A_a) — The aperture area of a collector is the opening or projected area of collector through which the unconcentrated solar energy is admitted.

3.2.3 Gross Area of Collector (A_g) — The gross area of a solar collector is the overall projected area of the collector including its enclosure.

3.2.4 Heat Transfer Fluid — The heat transfer fluid is the medium by which thermal energy is transferred between the components in a system.

To access Indian Standards click on the link below:

https://www.services.bis.gov.in/php/BIS_2.0/bisconnect/knowyourstandards/Indian_standards/isdetails/

3.2.5 Storage — The storage device (storage vessel) is a thermal store for the energy transferred from the collector. It is the container(s) plus all the contents of the container(s) used for storing thermal energy. The heat transfer fluid and accessories such as heat exchangers, flow switching devices, valves and baffles which are firmly fixed to the thermal storage container(s) are considered part of the storage device. The container is usually a tank storing hot water.

3.2.6 Heat Exchanger — The heat exchanger is a device specifically designed to transfer heat between two physically separated fluids. Heat exchanges can have either single or double walls.

3.2.7 Differential Temperature Controller — A differential temperature controller is a device that is able to detect a small temperature difference, and to control pumps and other electrical devices in accordance with this temperature difference.

3.2.8 Auxiliary Heat Source — An Auxiliary heat source (auxiliary heater) is a source of thermal energy, other than solar energy, used to supplement the output of the hot water system. It often takes the form of an electrical resistance heater.

3.3 Radiation and Solar Angles

3.3.1 Radiation — Radiation is the emission or transfer of energy in the form of electromagnetic waves.

3.3.2 Radiant Flux — Radiant flux is power emitted, transferred or received in the form of radiation.

3.3.3 Irradiance (measured in W/m^2) — The irradiance at a surface is the ratio of the radiant flux incident on the surface to the area of that surface. Solar irradiance is sometimes termed ‘incident solar radiation intensity’, ‘instantaneous insolation’, or ‘incident radiant flux density’.

3.3.4 Irradiation (measured in J/m^2) — The irradiation of a surface is the time integral of the irradiance at that surface. Irradiation is sometimes termed radiant exposure.

3.3.5 Solar Radiation — Solar radiation is the radiation emitted by the sun. (Approximately all of the solar energy incident at the earth’s surface is at wavelengths less than 4.0μ , and is often termed shortwave radiation).

3.3.6 Direct Solar Radiation — Direct solar radiation

is the solar radiation received at a surface from the solid angle subtended by sun’s disk.

3.3.7 Diffuse Solar Radiation — Diffuse solar radiation is the solar radiation received at a surface from a solid angle of 2π with the exception of the solid angle subtended by the sun’s disk.

3.3.8 Global Solar Radiation — Global solar radiation is the sum of the direct and diffuse solar radiation incident on a surface from a solid angle of 2π .

3.3.9 Angle of Incidence of Direct Solar Radiation — The angle of incidence of direct solar radiation is angle between the direct solar radiation beam and the outward drawn normal from the plane of the collector.

3.3.10 Solar Noon — For any given location solar noon is the local time of day when the sun is at its highest altitude for that day, is the time when the sun crosses the observer’s meridian.

3.4 General Concepts

3.4.1 Surrounding Air Temperature — The surrounding air temperature (ambient air temperature) is the mean temperature of the air within 10 m of the collector or storage device, whichever is applicable, measured by a sensor which is shielded from solar radiation and placed at least 1 m above the local ground surface.

3.4.2 Surrounding Air Speed — The surrounding air speed is the speed of the ambient air passing over the collector at a distance of 50 mm above its aperture.

3.4.3 Wind Speed — The wind speed is the speed of the air measured in accordance with the recommendations of the World Meteorological Organisation normally measured ten metres above ground level.

3.4.4 Water Draw-off Rate — The water draw-off rate is the rate at which domestic hot water is withdrawn from the system.

3.4.5 Draw-off Temperature — The draw-off temperature is the temperature of hot water withdrawn from the system.

3.4.6 Collector Tilt Angle — The collector tilt angle is the lower angle between the aperture plane of a solar collector and the horizontal plane.

4 UNITS SYMBOLS

<i>Sl No.</i>	<i>Symbol</i>	<i>Meaning</i>	<i>Units</i>
(1)	(2)	(3)	(4)
i)	A_a	Aperture area of collector	m ²
ii)	A_d	Equivalent area of the system	m ²
iii)	A_g	Gross area of collector	m ²
iv)	A_s	Effective area of the system	m ²
v)	C	Thermal capacity of storage tank	J/K
vi)	c_p	Specific heat capacity	J/kg°C
vii)	D	Date	Y-M-D
viii)	e	Error of curve fit	—
ix)	G	Solar irradiance	W/m ²
x)	G_d	Diffuse solar irradiance	W/m ²
xi)	G_L	Longwave irradiance (4 µm)	W/m ²
xii)	G_m	Maximum irradiance on the collector aperture	W/m ²
xiii)	LT	Local time	hour
xiv)	$K(v)$	Incidence angle modifier	—
xv)	h	Heat transfer coefficient	W/°C
xvi)	H	Solar irradiation at collector aperture	MJ/m ²
xvii)	H_d	Diffuse solar irradiation at collector aperture	MJ/m ²
xviii)	m	Mass of flow rate	kg/s
xix)	M_g	Mass of water in the storage tank	kg
xx)	M^*	Thermal mass of the storage tank	kg
xxi)	N	Number of data points	—
xxii)	N_h	Number of hours in a month	—
xxiii)	q	Flow rate of water drawn-off from system	l/s
xxiv)	Q	Energy extracted from the system	MJ
xxv)	Q_{aux}	Energy consumed by auxiliary heat source	MJ
xxvi)	Q_c	Energy contained in a volume, V_c of water extracted from the system	MJ
xxvii)	Q_{load}	Energy content of hot water load	MJ
xxviii)	Q_{losses}	Thermal losses from the store	MJ
xxix)	Q_{out}	Useful energy extracted from the system	MJ
xxx)	Q_R	Energy remaining in the system after a volume of water has been extracted	MJ
xxxi)	Q_{sol}	Solar energy transferred to the store	MJ
xxxii)	t	Time	s
xxxiii)	T_a	Ambient or surrounding air temperature	°C
xxxiv)	$T_a(\text{day})$	Ambient or surrounding air temperature during a 12 hour day time period	°C
xxxv)	T_{as}	Ambient or surrounding air temperature in location of store	°C
xxxvi)	T_c	Cold water temperature	°C
xxxvii)	T_d	Temperature of water drawn-off from the store	°C
xxxviii)	T_e	Store or collector outlet (exit) temperature	°C
xxxix)	T_f	Final temperature	°C
xl)	T_h	Required hot water temperature	°C

<i>Sl No.</i>	<i>Symbol</i>	<i>Meaning</i>	<i>Units</i>
(1)	(2)	(3)	(4)
xli)	T_i	Store or collector inlet temperature; initial temperature	°C
xlii)	T_s	Average (mean) temperature of water in the store	°C
xliii)	u	Surrounding air speed	m/s
xliv)	U_s	Store heat loss coefficient	W/°C
xlv)	U_t	Heat loss coefficient of collector and piping	W/°C
xlvi)	V_s	Fluid capacity of the store	l
xlvii)	V_c	Volume of daily hot water consumption	l
xlviii)	Δt	Time interval	S
xliv)	ΔT	Temperature difference	°C
l)	ϕ	Latitude	—
li)	η_0	Collector thermal efficiency	—
lii)	ρ_w	Density of water	kg/m ³
liii)	(av)	Average (mean) value of parameter	—
liv)	(day)	Average (mean) value of parameter during the period 6 hours before solar noon to 6 hours after solar noon	—
lv)	(Max)	Maximum value of parameter	—

5 TEST FACILITY REQUIREMENTS

5.1 System Mounting and Location

In this section, recommendations are made concerning the structure on which DWH systems should be mounted during testing and monitoring, and the local environment surrounding both the storage and the collectors. These recommendations apply to outdoor testing and testing in solar simulators.

5.1.1 Safety

The system should be mounted in a manner such as to ensure safety to personnel. Due consideration should be paid to the likelihood of glass failure and the leakage of hot liquids, etc mountings outdoors should be able to withstand the effects of wind gusts.

5.1.2 System Mounting

Whenever possible the system should be mounted on the mounting structure provided by the manufacturer. If no mounting is provided, then unless otherwise specified (for example when the system is part of an integrated roof array) an open mounting system is recommended. The system mounting should in no way obstruct the aperture of the collectors and the mounting structure should not significantly affect the back or side insulation of the collectors or storage vessel.

5.1.3 Tilt Angle

The tilt angle at which the system should be mounted is specified in each test procedure. In order to test systems at tilt angles recommended by

manufacturers or specified for actual installation, test frames allowing fixed tilt angles between 0° and 60° may be required.

5.1.4 Storage Tank Location

Except for systems where the storage vessel is fixed to the collectors in some way (for example integral collector storage systems and close coupled thermosiphon systems) the store should be installed, in the lowest position allowed in the manufacturers installation instructions.

5.1.5 Pipework between the Collector and Store

For systems where the hot water store is separate from the collectors, the total length of the connecting pipes between the collector and store should be 10 m. The diameter of the pipes should be in accordance with the manufacturer's installation instructions. The pipe insulation should be 1 cm thick and its thermal resistance should be at least 0.25 m²K/W.

5.1.6 Controller

Any controller included in the system should be set in accordance with the manufacturer's instructions OT if no instructions are supplied then the controller should be set for the minimum temperature difference. If 'user' adjustments are available, then these should be set to the minimum temperature difference positions

5.1.7 Heat Transfer Fluid

The heat transfer fluid used in the system during testing should be the fluid recommended by the

manufacturer. When testing forced-circulation systems, the fluid flow rate recommended by the manufacturer should be used.

5.2 Field of View Outdoors

5.2.1 Collector Orientation

The collector should be mounted in a fixed position facing south.

5.2.2 Shading from Direct Solar Irradiance

The collector should be located such that a shadow will not be cast into the collector at any time during the test period.

5.2.3 Diffuse and Reflected Solar Irradiance

5.2.3.1 For the purposes of test analysis, solar irradiance not coming directly from the sun's disk is usually assumed to come isotropically from the hemispherical field of view of the collector. In order to minimize the errors resulting from this approximation the collector of a system should be located where there will be no significant solar radiation reflected into it from surrounding buildings or surfaces during the tests, and where there will be no significant obstructions in the field of view. The reflectance of most rough surfaces such as grass, weathered concrete or chippings is not usually high enough to cause problems during collector testing. Surfaces to be avoided in the collector's field of view include large expanses of glass, metal or water.

5.2.3.2 Not more than 5 percent of the collector's field of view should be obstructed, and it is particularly important to avoid buildings or large obstructions subtending an angle of greater than 15 degrees with the horizontal in front of the collectors. Radiation reflected into the back of the collector is less important than that reflected into the front for most collectors. However, the field of view behind the collector can significantly influence the performance of collectors with little back insulation and evacuated tubular collectors, hence influencing the performance of the system.

5.2.4 Thermal Irradiance

The temperature of surfaces adjacent to the system should be as close as possible to that of ambient air. For example, the field of view of the system should not include chimneys, cooling towers or hot exhausts.

5.2.5 Wind

5.2.5.1 The performance of many collectors is sensitive to air speeds over the collector in the range 0 m/s to 3 m/s. In order to maximize the

reproducibility of results, collectors should be mounted such that air with a mean speed of between 3 m/s and 5 m/s will freely pass over the aperture, back and sides of the collector. If it is possible to control the wind speed to this degree, then the mean wind speed should be kept within 3 m/s and 8 m/s.

5.2.5.2 The use of artificial wind generator to achieve these wind speeds may be necessary in some locations. The average speed of the air flowing over the collector should lie between 3 m/s and 8 m/s when measured in the plane of the collector at a distance of 50 mm the surface of the cover, and at no point over the collector aperture should the speed deviate from the mean by more than ± 25 percent. The speed at any point over the collector aperture should remain steady and the temperature of the air leaving the wind generator should lie within ± 1 °C of the ambient air temperature.

5.2.5.3 Warm currents of air, such as those which rise up the walls of a building should not be allowed to pass over the system. Where system are tested on the roof of a building, they should be located at least 2 m away from the roof edge. Collectors designed for integration into a roof may have their backs protected from the wind, though this must be reported with the test results.

5.3 Test Installations for Component Testing and Monitoring of System Performance

For the component testing and system monitoring outlined in [5](#) the following test facilities are required. The guidelines given in [5.1](#), [5.2](#) and [5.3](#) on system mounting system location and test facilities should also be followed.

5.4 Storage Testing Facility

An example of a test facility for storage testing is shown in [Fig. 1](#). The storage tests should be conducted using an electrical heater and pump to simulate the input of the collector to the store, and a draw-off system to simulate hot water consumption. The electrical heater should be able to keep the heat transfer fluid at a constant temperature and be capable of supplying a constant power to the heat transfer fluid. The ambient temperature in the test facility should be between 20 °C to 25 °C. It should be monitored during testing. The temperature inside the store should be measured at several points, including the top and bottom of the tank.

5.5 Test Facility for Monitoring System Performance

An example of test facility for monitoring system performance is shown in [Fig. 2](#). The recommendations in [5.1.5](#) and [5.3](#) may be followed.

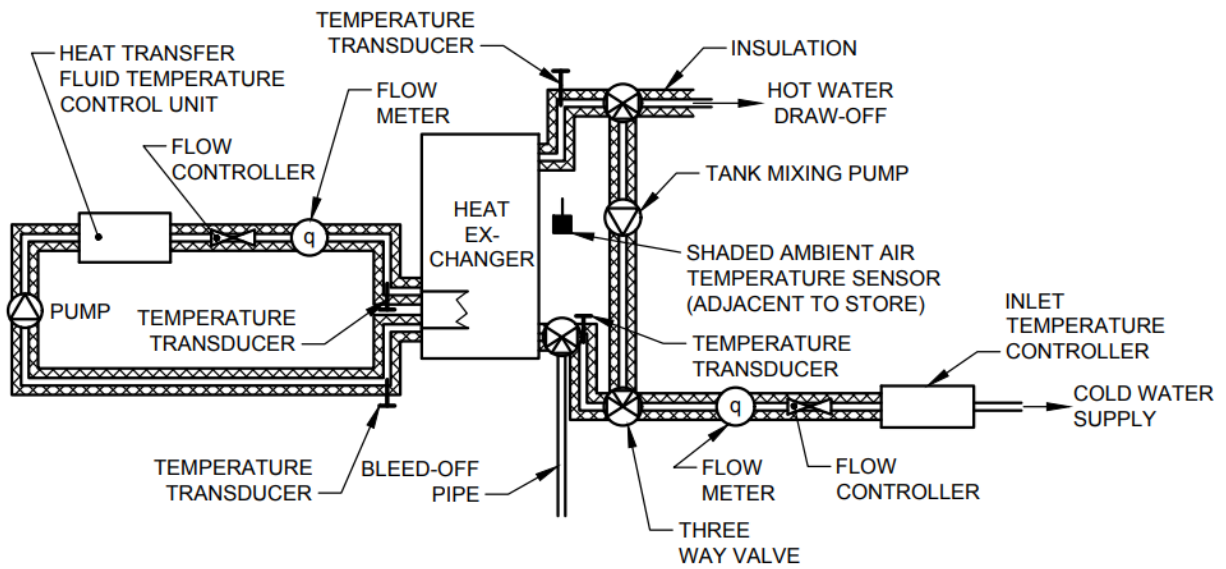

FIG. 1 EXAMPLE OF A STORAGE TESTING FACILITY

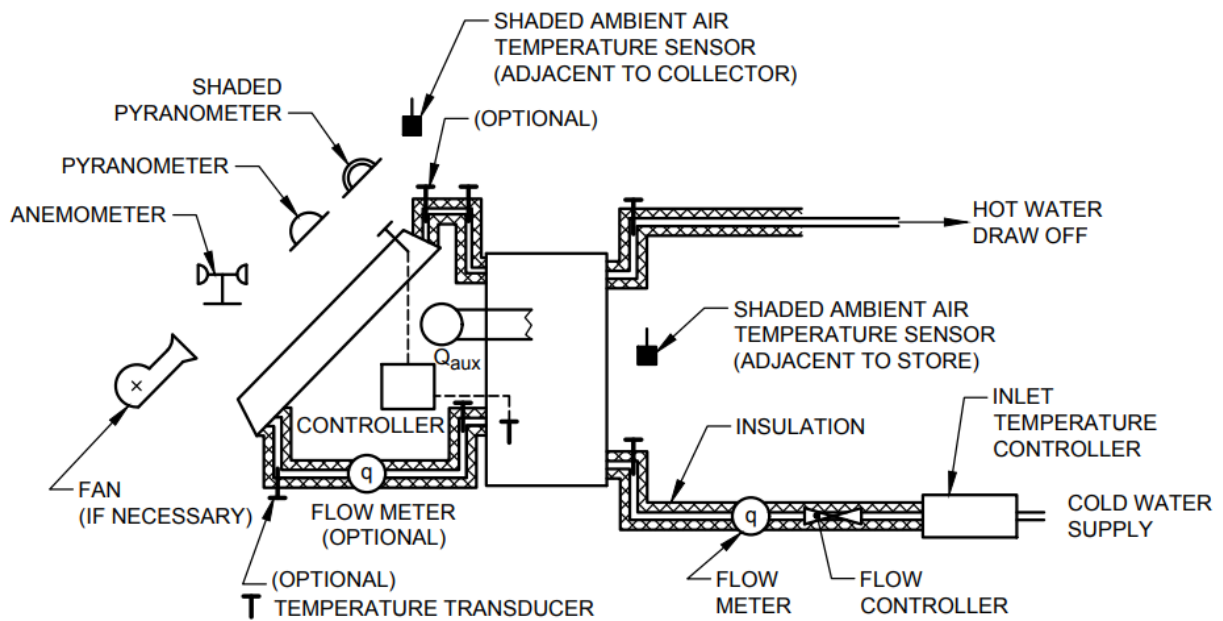

FIG. 2 EXAMPLE OF A TEST LOOP FOR THE MONITORING OF SYSTEM PERFORMANCE

6 INSTRUMENTATION FOR USE IN SYSTEM TESTING

The test methods used for the determination of the performance of solar domestic hot water heating systems require the measurement of experimental variables as shown in [Table 1](#).

6.1 Solar Radiation Measurement

6.1.1 Solar Radiation Measuring Instruments

6.1.1.1 Pyranometer

A pyranometer is an instrument for measuring the solar irradiance from a solid angle of 2π on a plane surface. When the solar radiation coming from the solid angle of the sun's disk is obscured from the instrument, a pyranometer can be used to determine the diffuse solar irradiance on a plane surface.

6.1.1.2 Pyrliometer

A pyrliometer is an instrument normally used to measure the total irradiance including all wavelengths from a small solid angle. When orientated towards the sun, a pyrliometer can be used to determine the direct solar irradiance.

6.1.1.3 Pyrradiometer

A pyrradiometer is an instrument for measuring the

total irradiance of all wavelengths from a solid angle of 2π on a plane surface.

6.1.2 Pyranometers

Pyranometers (some types of which are termed solarimeters) have the characteristics given in [Table 2](#). Pyranometers have a hemispherical field of view and are therefore able to measure total solar irradiance that is the sum of direct, diffuse and ground reflected solar radiation. Only pyranometers meeting the 1st Class classifications should be used for collector and system testing.

6.1.3 Mounting, Maintenance and Calibration of Pyranometers

6.1.3.1 The pyranometer should be mounted such that its detector is located in the plane of the collector, at the mid height. The mounting position is shown pictorially in [Fig. 1](#). Pyranometers are primarily designed for use in a horizontal position and are fitted with a large white disc to shade the instrument body from solar radiation. When pyranometers are used in a tilted position additional protection is required to shade the back of the instrument from diffuse solar radiation.

Table 1 Measurement Accuracies Required for Testing the Performance of DHW Systems

([Clauses 6](#) and [7.2.2.3](#))

Sl No. (1)	Experimental Variable (2)	Precision (3)	Accuracy (4)
Measurement Required in all Test Methods:			
i)	Local time	+ 0.01 h	+ 0.01 h
ii)	Solar irradiance	—	—
iii)	Surrounding air speed	± 0.5 m/s	± 0.5 m/s
iv)	Ambient air temperature	± 0.2 °C	± 0.2 °C
v)	Temperature of cold water inlet to store	± 0.1 °C	± 0.1 °C
vi)	Difference in temperature of water at cold water inlet to store and hot water outlet of store	± 0.1 °C	± 0.1 °C
vii)	Flow rate of water during hot water draw-off	± 1 %	± 1 %
Measurement Only Required in Component Testing and System Monitoring:			
viii)	Temperature inside store	± 0.1 °C	± 0.1 °C
ix)	Temperature of heat transfer fluid at inlet to heat exchanger or store	± 0.1 °C	± 0.1 °C
x)	Difference in temperature of heat transfer fluid at inlet and outlet of heat exchanger or store	± 0.1 °C	± 0.1 °C
xi)	Mass flow rate of heat transfer fluid in collector loop	± 1 %	± 1 %
xii)	Auxiliary energy use during monitoring period	± 2 %	± 2 %

NOTE — Precision refers to the repeatability error, or the uncertainty involved in interpreting the reading of the measurement. Accuracy refers to the maximum permissible bias error, or the difference between the measured value and the true value.

6.1.3.2 Pyranometers should be well ventilated with ambient air on all surfaces both in front and behind. Any heating of the instrument body is likely to cause measurement errors. The cables should be shielded from direct solar radiation and screened from electromagnetic interference. Prior to collector or system testing the glass dome of the pyranometer should be cleaned and checked to ensure that it is free of condensation. If condensation is present, then the desiccant in the instrument should be dried. No condensation can be accepted whilst the instrument is in use. In order to measure the total irradiance at the collector aperture including ground reflected irradiance the pyranometer should be mounted the plane of the collector (that is usually tilted at 45°).

6.1.3.3 The variation of most pyranometer calibrations with tilt angle is small (1 percent), but if possible the pyranometer should be calibrated at the tilt angle for which it will be used. The zero offset of a pyranometer may be checked by placing a light-tight box over it. A pyranometer will not always give a zero reading outdoors at night because of the low values of effective sky temperature which sometimes occur. Low sky temperatures depress the zero reading of pyranometers.

6.1.4 Diffuse Solar Radiation Measurement

6.1.4.1 Use of shade disc

The diffuse solar irradiance in the plane of a collector may be determined by shading the detector

of the pyranometer from the direct solar radiation in the solid angle subtended by the sun's disc. This may be accomplished by using an opaque disc of approximately 50 mm diameter attached to a slender rod on a direct line between the detector and the sun. The disc should be held at a distance such that just the dome of the pyranometer is shaded.

6.1.4.2 Use of shade ring

As an alternative to a shade disc, a second pyranometer may be mounted adjacent to the first and fitted with a shade ring of suitable width such that the detector is shielded from direct solar radiation during the period in which tests are performed. The outer surface of a shade ring is white, its inner surface is black and it is mounted with its axis tilted at an angle to the horizontal equal to the latitude, such that the plane of the ring is parallel to the plane defined by the daily motion of the sun. The pyranometer is placed with its detector on the axis of the shade ring (either tilted to the same angle as a collector or horizontally), and the ring is moved every few days, following the declination of the sun, to keep, the pyranometer in shadow.

6.1.4.3 Shade ring correction factor

The reading from a pyranometer with a shade ring should be increased to allow for the region of sky obscured by the ring. The obscured fraction 's' may be calculated using the calculation given in [Annex A, Table 3](#) shows the value of 's' for typical tilt angles and latitudes.

Table 2 Classification of Pyranometer

([Clause 6.1.2](#))

SI No.	Characteristic	Secondary Standard	First Class	Second Class
(1)	(2)	(3)	(4)	(5)
i)	Resolution (smallest detectable change in W/m ²)	± 1	± 5	± 10
ii)	Stability (percentage of full scale, change/year)	± 1	± 2	± 5
iii)	Cosine response (percentage deviation from ideal at 10 percent solar elevation on a clear day)	< ± 3	< ± 7	< ± 10
iv)	Azimuth response (percentage deviation from the mean at 10° solar elevation on a clear day)	< ± 3	< ± 5	< ± 5
v)	Temperature response (percentage maximum error due to change of ambient temperature within the operating range)	± 1	± 2	± 5
vi)	Non-linearity (percentage of full scale)	± 0.5	± 2	± 5
vii)	Spectral sensitivity (percentage deviation from mean absorptance 0.3 µm to 3 µm)	± 2	± 5	± 10
viii)	Response time (99 percent response)	< 25 s	< 1 min	< 4 min

Table 3 Value of 's' for Typical Tilt Angles and Latitudes

(Clause 6.1.4.3)

SI No.	Latitude (°N)	Typical Tilt Angles		
		0°	45°	90°
(1)	(2)	(3)	(4)	(5)
i)	45	0.102	0.102	0.101
ii)	50	0.096	0.102	0.106
iii)	55	0.050	0.064	0.078

6.1.4.4 Use of pyrhelimeter

Diffuse radiation may also be determined from the difference between global radiation measurements made with a pyranometer and direct radiation measurements made with a pyrhelimeter pointed at the sun. The direct solar irradiance measurement needs to be corrected for the incidence angle between the solar beam and the plane of the pyranometer detector.

6.2 Temperature Measurement

The temperature measurements required for solar DHW system testing are the temperature of the cold water inlet to the system, the temperature of hot water drawn off from the store, and the ambient air temperatures adjacent to both the collector and the store. In addition, if the system is assessed using component testing, it is necessary to measure the temperature of the heat transfer fluid at the collector inlet and outlet, at the store inlet and outlet, and the temperature at various points in the store. The required accuracy and environment for these measurements are different and hence the transducer and associated equipment required may be different.

6.2.1 Temperature Measurement Instruments**6.2.1.1 Mercury in glass thermometers**

Mercury in glass thermometers are only used for calibration purposes and are available graduated at 0.1 °C or 0.05 °C intervals. The range of calibration reference thermometers is usually small (typically 30 °C), and hence more than one thermometer may be needed. Most thermometers are calibrated for total immersion in the fluid and hence errors will be introduced if the thermometers are used when only partially immersed. Good thermal contact with the fluid is essential. Calibration reference thermometers should be regularly re-calibrated over their operating range by a recognized standards laboratory.

6.2.1.2 Platinum resistance thermometers

Platinum resistance thermometers (PRTs) have an especially stable and reproducible resistance/temperature relationship. For this reason, PRTs offer an accurate method of measuring temperature. The temperature resistance relationship for PRT may be expressed either as:

$$R_T/R_0 = 1 + a_1[T - a_2(T/100 - 1)(T/100)] \quad \dots(1)$$

$$T = a + b\sqrt{c - R_T} \quad \dots(2)$$

Where R_T is the thermometer resistance at temperature T °C, R_0 is the thermometer resistance at 0 °C, and a_1 , a_2 , a , b and c are constants for the individual thermometer. Calibration of the thermometer, associated connecting leads, bridge circuit and readout device should be performed approximately once per year in a temperature controlled water or oil bath.

In order to obtain accurate results from PRT compensation must be provided for the resistance of the leadwires, which will vary with the length of the wire and the ambient temperature in the surroundings of the leadwire. The PRT may be used in four basic configurations, two wires three wires, four wires and four wires compensated. A basic two wire arrangement where the PRT forms one arm of a Wheatstone bridge is shown in Fig. 3. The total resistance seen by the bridge is the measuring resistance of the PRT plus the resistance of the leadwire. At 20 °C, the resistance of a typical PRT is approximately 110 ohms so, a total lead resistance of one or two ohms will alter the temperature reading by one or two percent. The two wire arrangement should only be used when the leadwire resistance may be considered an additive constant. It

is not recommended for general use in collector and system testing. In the three wire arrangement shown in [Fig. 4](#), a third leadwire, which should be of the same length of the sensor lead wire provides a measurement of the resistance of the leadwire and is used to compensate for the resistance of the sensor leadwires. The two four wire arrangements shown in [Fig. 5](#) and [Fig. 6](#) provide highly accurate measurements of the PRT resistance value, compensating for both leadwire resistance and ambient temperature. In the arrangement shown in [Fig. 5](#) one pair of wires passes a constant current through the sensor from a constant current generator and a second pair of wires measures the voltage across the sensors. The second pair of wires feeds into a high impedance amplifier, so that the resistance of the leadwires is negligible. In the compensated four wire arrangement shown in [Fig. 7](#) the PRT lead impedances are assumed to be equal.

6.2.1.3 Quartz thermometers

Quartz thermometers employ a precisely cut quartz crystal which has a stable and repeatable relationship between resonant frequency and temperature. Each probe is factory calibrated and supplied with its own calibration module for use in the thermometer unit. Quartz is capable of very high accuracy but is rather expensive.

6.2.1.4 Thermocouples

Thermocouples have been widely used for solar collector testing, but great care is needed in order to minimize electrical noise and unwanted voltages in thermocouple circuits. In recent years, PRT's and semi-conductor devices have increasingly been used in place of thermocouples because of their higher signal levels and because they are less prone to errors. A thermocouple is formed by joining together two wires made of dissimilar metals. When the free ends of the wires are held at a reference temperature, usually 0 °C. A voltage E is generated

which is a non-linear function of temperature (T). This function may be approximated by:

$$T = b_c + b_1E + b_2E^2 \quad \dots(3)$$

Suitable pairs of thermocouple materials are copper/constantan, iron constantan and chromel/alumel. As the voltage generated by a thermocouple is derived from both the junctions and the wires close to the junctions in which there is a temperature gradient, care must be taken in both their construction and use if high accuracy is to be ensured. Junctions should not be placed directly into water, but should be protected by a suitable dielectric compound and encapsulated in a metal sheath to provide protection from corrosion, and to ensure that the wires are not subjected to stresses which might change the calibration of the junction.

Most suppliers of thermocouple materials offer a wide range of encapsulated junctions which are suitable for use in collector and system testing. The connections between a thermocouple and the readout device will produce unwanted voltages unless compensated for, either thermally or electrically, as shown schematically in [Fig. 7](#) and [Fig. 8](#) respectively.

All connecting leads should be screened from electromagnetic interference, and suitable connections should be used to minimize the risk of unwanted voltages. Proprietary plugs and sockets are available on the market for the common thermocouple systems, but to avoid electrical noise it is important to keep these clean. Heat leakage along connecting leads can be minimized by using thin leads, insulation, and adequate depths of immersion. A thermocouple should be calibrated against a reference thermometer over the range of temperatures for which it is to be used, and a calibration curve obtained. Annual checks at a few selected points on the calibration curve should be sufficient to verify the calibration.

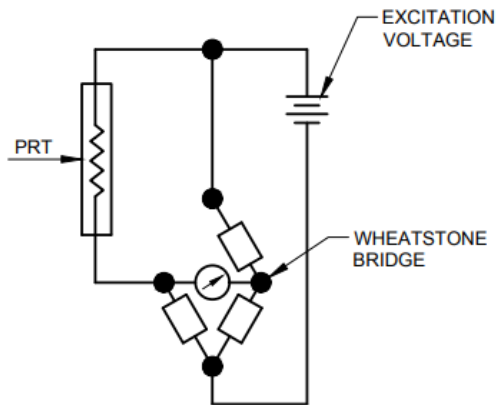

FIG. 3 TWO WIRE ARRANGEMENT FOR PRT SENSOR

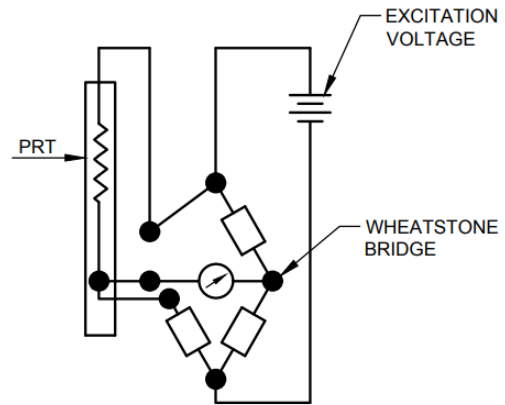

FIG. 4 THREE WIRE ARRANGEMENT FOR PRT SENSOR

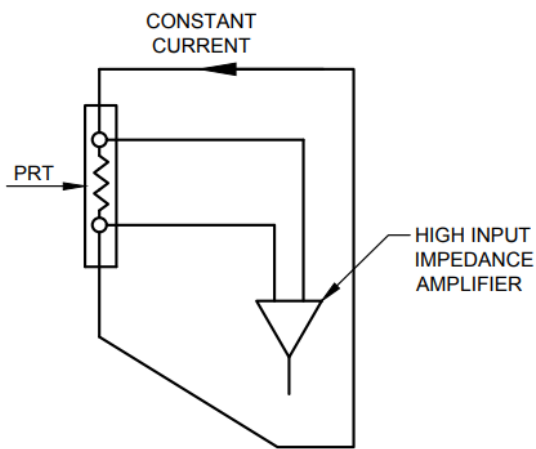

FIG. 5 FOUR WIRE ARRANGEMENT FOR PRT SENSOR

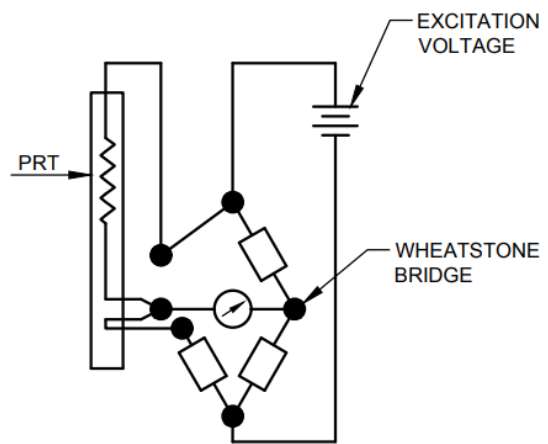

FIG. 6 FOUR WIRE COMPENSATED ARRANGEMENT FOR PRT SENSOR

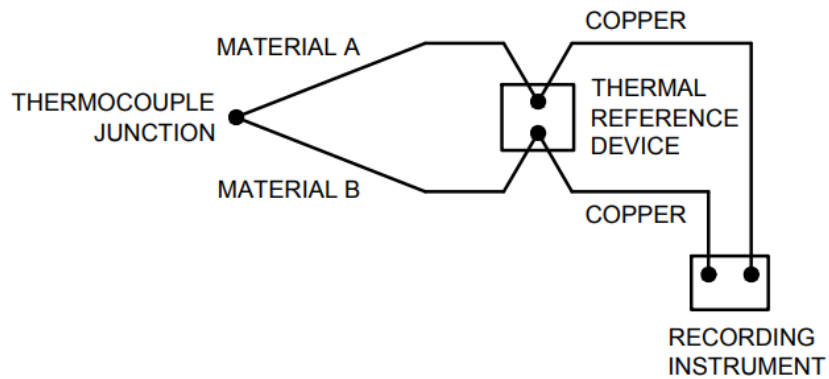

FIG. 7 ARRANGEMENT FOR THERMAL COMPENSATION OF THE JUNCTION BETWEEN THE RECORDING INSTRUMENT AND THERMOCOUPLE

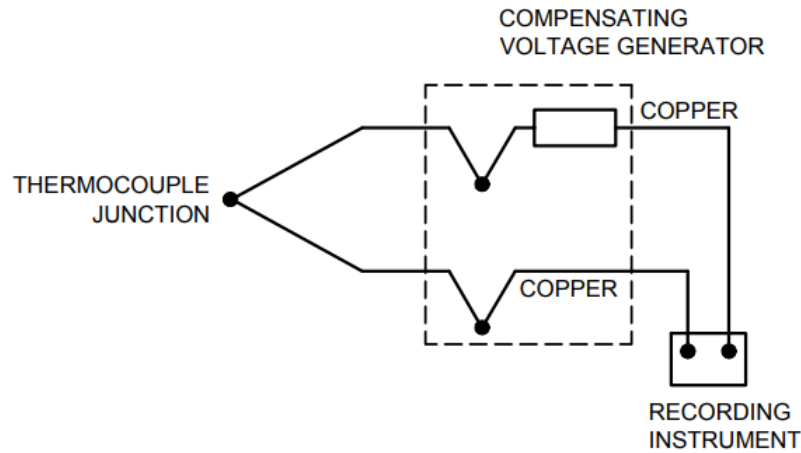

FIG. 8 ARRANGEMENT FOR ELECTRONIC COMPENSATION OF THE JUNCTION BETWEEN THE RECORDING INSTRUMENT AND THERMOCOUPLE

6.2.2 Measurement of Temperature of Water at Inlet and Outlet of the Store

6.2.2.1 Required accuracy

The temperature of the water at the inlet and outlet of the store should be measured to an accuracy of ± 0.1 °C.

6.2.2.2 Mounting of sensors

The transducer should be mounted at no more than 200 millimetres from the outlet or inlet of the store. If it is necessary to position it outside this range then it should be verified that the fluid temperature measurement is not affected. To ensure mixing of the water at the position of temperature measurement, a bend in the pipework, an orifice or a fluid mixing device should be placed upstream of the transducer, and the transducer probe should point upstream as shown in [Fig. 9](#).

6.2.3 Measurement of Heat Transfer Fluid Temperature Difference (ΔT)

6.2.3.1 Required accuracy

In component testing, the temperature difference

between the collector outlet and inlet and the temperature difference between the inlet and outlet of the heat exchanger needs to be measured to an accuracy of ± 0.1 °C in order to achieve ± 1 percent accuracy for temperature differences of 10 °C. Accuracies approaching ± 0.02 °C can however be achieved with high quality modern measuring systems, and hence it is possible to measure temperature differences down to, 1 °C or 2 °C with a reasonable accuracy.

6.2.3.2 Transducer arrangements and calibration checks

6.2.3.3 Platinum resistance thermometers

Platinum resistance thermometers (PRTs) may be arranged differentially to measure temperature difference. A matched pair of PRTs is required with some instruments, whilst in others the matching can be accomplished during calibration by a simple adjustment of the equipment. A zero check for PRTs should be performed regularly by placing both PRTs in a well stirred fluid bath at several temperatures spaced over the operating range.

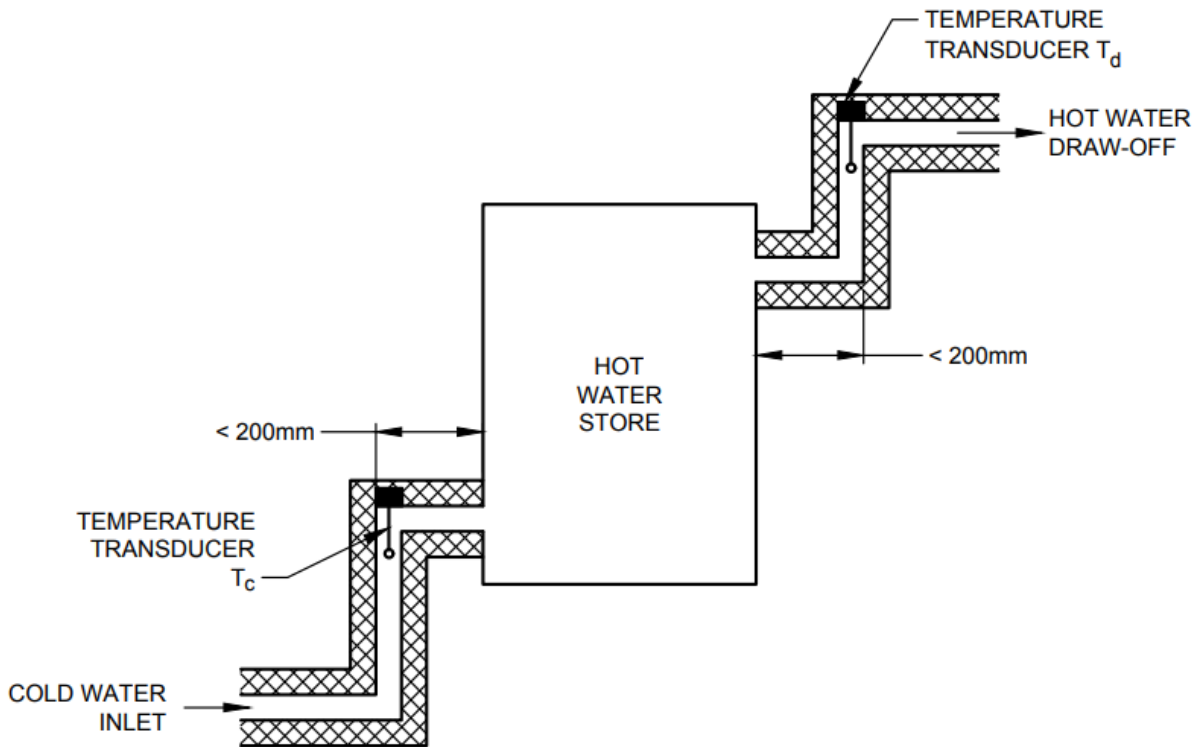

FIG. 9 RECOMMENDED TRANSDUCER POSITIONS FOR MEASURING THE TEMPERATURE OF WATER AT THE INLET AND OUTLET OF THE STORE

6.2.3.4 Thermopiles

Thermocouples may be connected in series to form thermopiles (see Fig. 10) and used to measure temperature differences. To provide sufficient resolution, the minimum number of junctions recommended is 6 (3 by 3), and they should be electrically insulated from each other. The relationship between voltage and temperature for a thermocouple varies with absolute temperature, and it is therefore important to calibrate differential thermopiles as a function of absolute temperature. Differential thermopiles may be calibrated by placing the cold junctions in one well stirred fluid bath and the hot junctions in another, each with a reference thermometer. For high accuracy, it is preferable to perform the calibrations using the same

readout instrumentation as is used for system testing.

6.2.4 Measurement of Surrounding Air Temperatures (T_a)

6.2.4.1 Required accuracy

The ambient or surrounding air temperature should be measured to an accuracy of ± 0.5 °C.

6.2.4.2 Mounting of sensors

For outdoor measurements the transducer should be shaded from direct and reflected solar radiation by means of a white painted, well ventilated shelter, such as a meteorological screen, or by two concentric vertical metal pipes. The shelter should

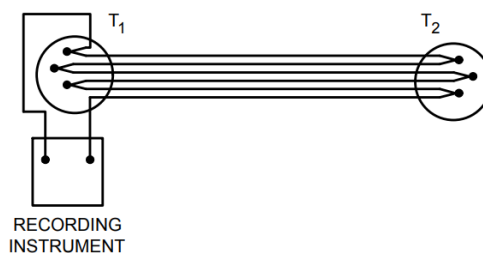

FIG. 10 THERMOPILES ARRANGEMENT FOR MEASURING THE TEMPERATURE DIFFERENCE ACROSS THE SOLAR COLLECTOR OR HEAT EXCHANGER

be placed at the mid height of the collector but at least 1 metre above the local ground surface to ensure that it is away from the influences of ground heating. The shelter should be positioned to one side of the collector within 10 metres of it. If air is forced over the collector by a wind generator, the air temperature should be measured in the outlet of the wind generator and checks made to ensure that this temperature does not deviate from the surrounding air temperature by more than ± 1 °C. A typical arrangement of an ambient air temperature sensor is shown in [Fig. 11](#).

6.3 Flowrate Measurement

6.3.1 Flowrate Measuring Instruments

Both the turbine meters and magnetic flow meters described below are unaffected by the viscosity of the fluid and are capable of accuracies within ± 1 percent. The accuracy of a flowmeter is usually specified as a percentage of the full scale reading, and therefore meters with a suitable flowrate range should be used. Both magnetic and turbine meters measure volumetric flowrate and hence the density of the fluid must be known as a function of temperature. The variation of density with temperature for water is given in [Annex B](#).

6.3.1.1 Magnetic flowmeters

The range of commercially available magnetic flowmeters has increased substantially over the last few years and some inexpensive meters of this type are now available. They have a high accuracy and usually introduce only a very small pressure drop.

6.3.1.2 Turbine meters

Turbine meters are widely used for collector and system testing since accuracies of within ± 1 percent may be achieved if the device is suitably

calibrated over the flowrate range. In order to protect these rather delicate instruments, special attention should be given to ensuring that the fluid is free of entrained air and contaminants. The calibration of turbine meters should be checked frequently, for example before each new system test, to ensure that the required accuracy of ± 1 percent is maintained.

6.3.2 Measurement of Water Flowrate during Hot Water Draw-off

6.3.1.1 Required accuracy

The mass flowrate of the water during the draw-off of hot water should be measured to an accuracy of within ± 1 percent. In order to ensure that this accuracy is maintained, it is recommended that the flow meter be calibrated before each series of system tests. The output signal from a flowmeter may be either in the form of a voltage or a series of pulses. If a pulse output is used, then the number of pulses per unit volume should be high enough to permit a resolution of better than ± 1 percent in the flowrate.

6.3.2.2 Calibration

The flow meter should be calibrated at a flow rate of 600 l/h and over the fluid temperature to be used during system testing. If component testing is carried out flow meters may be required to measure other flow rates. Meters should then be calibrated over the range of fluid flowrates and temperatures to be used during component testing. The recommended method of calibration is to collect the fluid downstream of the flow rate transducer over a period of approximately 60 s. The mass of the fluid collected should then be accurately determined and the average flow rate over the period obtained. It is important that during this period the flow rate is maintained constant to within 21 percent. This may

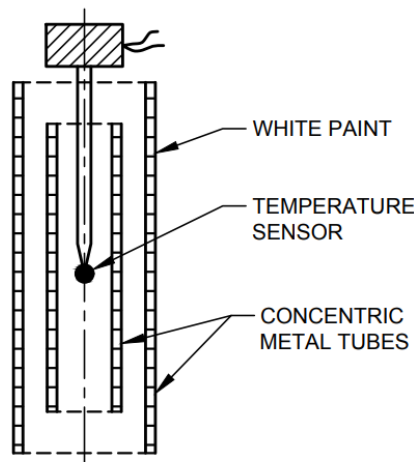

FIG. 11 AMBIENT AIR TEMPERATURE SENSOR

be achieved by means of a constant head device.

6.4 Air Speed Measurement

6.4.1 Air Speed Measuring Instruments

6.4.1.1 Cup anemometers

A cup anemometer is a device for measuring the total horizontal component of air speed and is suitable for outdoor testing when no forced air movement is employed. A cup anemometer does not indicate the direction of the air movement.

6.4.1.2 Vane anemometers (air meters)

A vane anemometer consists of a number of vanes supported on short radial arms and mounted on a spindle. It is a directional transducer which measures the air speed in the direction of the spindle axis. These instruments contain a hot element which is cooled by the air. The resistance of the element changes with temperature and also with air speed. Hand held devices are especially suited for determine the air speed at various positions around the system. Most models are directional transducers. Hot wire anemometers are expensive and may be damaged easily. Hot thermistors are more suitable for system testing.

6.4.1.3 Vortex anemometers

Vortex anemometers, which sense the formation frequencies of vortices created by the air flowing past an obstruction, may be used for measuring the air speed both, indoors and outdoors. Most models are directional transducers.

6.4.1.4 Pressure tubes (Pilot tubes)

Pressure tube anemometers are suitable for the measurement of air speed both indoors and outdoors. The pressure tube is a directional transducer.

6.4.2 Measurement of Surrounding Air Speed

The heat losses from a collector increase with the air speed over the collector but the influence of wind direction is not well understood. Measurements of wind direction are therefore not used for collector or DHW system testing. The relationship between the meteorological wind speed and the air speed over the collector depends on the location of the test facility, so meteorological wind speed is not a useful parameter for collector or DHW system testing. By using the wind speed measured over the collector it is possible to define clearly the conditions in which the tests were performed.

6.4.2.1 Mounting of sensors

For outdoor and indoor testing the air speed may vary from one end of the collector to the other. A series of measurements should therefore be taken at a distance of 50 mm in front of the collector aperture. At equally spaced positions over the collector area. An average value should then be determined. Non-directional measurements may be using a directional transducer if a vane is used to keep the transducer pointing in the direction of the air movement. When testing outdoors in unsteady wind conditions it may be necessary to obscure part of the collector aperture from solar radiation in order to take sample measurements of the air speed. For this procedure the transducer and its mounting should obscure less than 5 percent of the collector aperture for less than 10 percent of the test period. Alternatively, an anemometer may be fixed to the middle of a board of the same size and mounting arrangement as the test collector and placed nearby.

6.4.2.2 Calibration

The anemometer should be recalibrated at yearly intervals.

6.5 Data Recording

6.5.1 General

The quality of the test results depends on the design and maintenance of the system used for measuring the test parameters. A measurement system includes transducers, signal conditioning units and readout equipment. Each of these three elements should be regularly calibrated and, where possible, the three should be calibrated together. The choice in data recording systems becomes wider each year. With the availability of microcomputers and instrument interfaces it is now cost effective to record, analyze and print out test results using a single set of equipment, and this is becoming an increasingly common approach. However, many laboratories retain a visual indication of the current status of parameters for the experimenter to monitor during a test, either as a computer display or by the use of digital indicators.

6.5.2 Signal Averaging

Data recorders must be able to accommodate small variations in transducer signals, and this implies the use of averaging techniques. The rate at which a signal should be sampled is related by statistical theory to the confidence in average values deduced from the readings. With this problem in mind, one can move towards the use of analogue integrators which can be sampled at a lower frequency and this minimise the quantity of stored data. The quality of the integrator should be good enough to maintain the

required accuracy of the parameter whose signal it is integrating.

7 TEST PROCEDURE

The complete testing procedure is to be done by the following steps:

- a) System parameter determination — Two options:
 - 1) Separate test of component; and
 - 2) Test of the complete unit.
- b) Establishment of system model using data from (a);
- c) Verification of the system model by comparison of monitored behavior of the system with the model simulation for the same weather and load-data as monitored;
- d) Choice of test reference year and load data for yearly performance; and
- e) Prediction of long term yearly performance for the system using the verified system model from step (a). System parameters from step (a) and weather and load data from step (d).

The component characteristics are used in a detailed transient computer simulation model of the system to predict the long term performance of the system. For new types of system, it is important to verify that the simulation model has been set up to give an accurate representation of the system and this is done by monitoring the system performance over a range of weather and load conditions and comparing the measurements made to those predicted by the model for the same conditions. For all systems the store model which is based on the characteristics determined in the store tests, is verified by a dynamic test of the store. Once verified the computer simulation model can be used to predict long term performance in any operating conditions. The model can also be used by manufacturers for the development and optimization of their systems and where a component is used in more than one system configuration, performance predictions for several systems can be made without having to re-test each component. The simulation method may also be used to determine the performance of relatively large systems.

7.1 System Component Characterization by Testing Component Separately (Step 1, Option A)

7.1.1 Introduction

In this approach to system testing, the system components (the collector, store and control system) are tested and characterized separately, as per [Annex C](#). For the testing of the collector the test

procedures recommended in IS 12933 (Parts 1 to Part 3 and Part 5) are to be followed.

7.1.2 Collector Testing

7.1.2.1 Collector efficiency test

The collector efficiency curve expressed in equation 7.1.1 should be determined for a collector tilt angle of 45°.

$$\eta = \eta_0 - a_1 (T_m - T_a)/G - a_2 (T_m - T_a)^2/G \dots(4)$$

The test procedures document or the procedure recommended in (1) should be used. For some computer models the use of the coefficient a_2 in the model is optional and only η_0 and a_1 , need to be determined. where the efficiency (η) are expressed by $(T_{fm} - T_a)/G$, where $T_{fm} = (T_{fi} + T_{fo})/2$.

$$F'(\tau\alpha)_{en} = \eta_0 = \underline{\hspace{10em}}$$

$$F'U_L = a_1 = \underline{\hspace{10em}}$$

or where the efficiency (η) are expressed by $(T_{fi} - T_a)/G$

$$F'.F''.(\tau\alpha)_{en} = FR(\tau\alpha)_{en} = \eta_0 = \underline{\hspace{10em}}$$

$$F'.F''.U_L = F_R.U_L = a_1 = \underline{\hspace{10em}}$$

$$\dot{m} = \underline{\hspace{10em}}$$

where

T_{fm} = Collector fluid mean temperature (°C);

T_a = Ambient air temperature outside collector (°C);

G = Solar irradiance (W/m²);

T_{fi} = Collector fluid inlet temperature (°C);

T_{fo} = Collector fluid outlet temperature (°C); and

\dot{m} = Test fluid flowrate (kg/s).

7.1.3 Testing of Control Systems

If a control system is included in the DHW system, the differential thermostat in the control system should be tested as follows.

7.1.3.1 Differential thermostat test

The differential thermostat should be tested using variable resistance boxes to simulate the resistances produced by the temperature sensors in the control system or by varying the temperatures of the sensors using temperature controlled oil baths. The store temperature sensor or its simulator should be set to the desired store temperature, T_{store} . The temperature

of the collector temperature sensor or its simulator should then be slowly increased. When the pump switch in the thermostat is activated, the starting temperature, T_{start} should be recorded. The temperature of the collector temperature sensor should then be slowly decreased. When the pump switch in the thermostat is turned off the temperature, T_{stop} should be recorded. The temperature differential necessary to start the pump is $T_{\text{start}} - T_{\text{store}}$. The temperature differential necessary to stop the pump is $T_{\text{stop}} - T_{\text{store}}$. The controller characteristics should be checked over the relevant range of storage operating temperatures.

7.1.4 Storage Testing

Four parameters should be determined for the store:

- The heat loss coefficient of the store while the system is at a standstill, which is during a period of cooling;
- The effective thermal capacity of the store (expressed in J/°C). This may be determined by testing the store or by calculation;
- The heat transfer coefficient of the heat exchange system between collector and store; and
- For thermosiphon systems only, the pressure drop across the heat exchanger for different fluid flow rates.

At the end of these tests, a dynamic test of the store should be performed, in order to provide measurements which can be used to validate the simulation model of the store. This test is described in 7.1.5.2. The storage test facility described in 5.4 should be used for the storage testing. Table 4 shows the measurements and frequency of measurements which should be made for the tests outlined in 7.1.4. Measurements should be made in

accordance with the recommendations in 6.

7.1.4.1 Measurement of the store heat loss coefficient

The store heat loss coefficient should be measured using the method described below:

The storage vessel should be heated to a uniform temperature by passing heat transfer fluid at a constant inlet temperature of 60 °C through the heat exchanger. The store should then be allowed to cool for 24 h. The temperature in the store and the ambient air temperature should be measured every hour. After 24 h the store is heated to a uniform temperature by circulating heat transfer fluid at a constant temperature and a flow rate of 0.07 kg/s through the heat exchanger. The temperature of the heat transfer fluid should be greater by at least 5 °C, then the temperature at the top of the storage vessel at the end of the 24 h cooling period. Temperatures

in the storage vessel and the temperature of the heat transfer fluid at the store inlet and outlet should be measured, and values averages over 30 min periods. The temperature in the tank may be assumed to be uniform when the average values of these temperatures deviate by less than 0.1 °C from the average temperature measured on the previous 30 min test period. Circulation of the fluid should be stopped when a uniform temperature has been reached. Assuming that the store heat loss coefficient and the ambient air temperature remain constant during the cooling period the store heat loss coefficient can be calculated as follows:

$$U_s = C \cdot \ln \left[\frac{(T_{s(\text{final})} - T_a)}{(T_{s(\text{initial})} - T_a)} \right] / \Delta t \quad \dots(5)$$

C is the effective thermal capacity of the store as calculated in next chapter. T_s (initial) and T_s (final)

Table 4 Measurements to be Made During Storage Testing

(Clauses 7.1.4 and 7.1.4.2)

SI No.	Measurement	Symbol	Frequency (Min)
(1)	(2)	(3)	(4)
i)	Temperatures in the storage tank	T_s (°C)	3
ii)	Ambient air temperature	T_a (°C)	3
iii)	Temperature of heat transfer fluid at the inlet to the heat exchanger/store	T_i (°C)	3
iv)	Temperature difference in heat transfer fluid at the inlet and outlet of the heat exchanger/store	$T_i - T_s$ (°C)	3
v)	Flow rate of heat transfer fluid	\dot{m} (kg/s)	3

denote the average temperature in the store at the beginning and end of the cooling period T_s (final) cannot be determined directly due to stratification effects in the store. It is calculated by measuring the heat needed to raise the store to a uniform temperature.

$$T_{s(\text{final})} = T'_s - Q_{\text{in}}/C \quad \dots(6)$$

where T'_s is the uniform temperature to which the store is heated and Q_{in} is the heat supplied to the store by the heat transfer fluid.

$$Q_{\text{in}} = \int_0^{t_1} m c_p (T_i - T_c) \quad \dots(7)$$

where t_1 is the duration of the heating period.

7.1.4.2 Effective thermal capacity of the storage vessel

The effective thermal capacity of the store is the total thermal capacity of the store, reduced by the thermal capacity of any dead zones in the tank. For example, large volumes of water below the heat exchanger, which are never heated by the heat exchanger. The effective thermal capacity of the storage tank may be calculated from the weight of the empty storage tank, the weight of water contained in the tank and by examination of drawings of the tank to determine dead zones in the tank. The effective thermal capacity of the store may also be determined experimentally as described below. A uniform temperature representative of the mains cold water temperature should be obtained in the tank. Heat transfer fluid should then be circulated through the heat exchanger in order to exchange heat tank. The fluid flow rate should be 0.02 l/min of water in the store and the temperature of the heat transfer fluid such that it supplies 10 W for each litre of water in the store. The circulation should be stopped when the temperature measured by the top sensor in the tank exceeds 75 °C. Measurements should be made as in [Table 4](#). The effective thermal capacity of the storage vessel is defined as follows:

Effective thermal capacity of the store

$$= \frac{\text{Increase in heat content of the store during test}}{\text{Increase in the mean temperature of the store during test}} \quad \dots(8)$$

$$C = Q_1 / (T_{s(\text{final})} - T_{s(\text{initial})}) \quad \dots(9)$$

Q_1 is the increase in the heat content of the store is calculated using equation (10).

$$Q_1 = \text{Heat supplied by heater} - \text{heat losses from store transfer fluid} \quad \dots(10)$$

$$\dot{Q}_1 = \sum_{i=1}^N \Delta t [\dot{Q}_{\text{in}}(i) - \dot{Q}_{\text{losses}}(i)] \quad \dots(11)$$

where Δt is the duration (30 min) of each i^{th} period during the test.

$Q_{\text{in}}(i)$ is the energy supplied by the heat transfer fluid during period (i) and is calculated according to equation (12).

$$Q_{\text{in}}(i) = m(i) c_p(i) [T_e(i) - T_i(i)] \quad \dots(12)$$

$Q_{\text{losses}}(i)$ is the losses from the storage tank during period (i), and is calculated according to equation (13).

$$Q_{\text{losses}}(i) = U_s [T_m(i) - T_a(i)] \quad \dots(13)$$

The total losses from the storage tank will be small compared to Q_{in} .

7.1.4.3 Measurement of the store heat exchanger heat transfer coefficient

The heat transfer coefficient indicates how much energy can be transferred from the heat transfer fluid to the store per °C of temperature difference between the heat transfer fluid and the store. The test procedure described in [7.1.4.2](#) may be used to calculate the heat transfer coefficient. For each 30 min period.

$$h = -\dot{m} c_p \ln[1 - (T_i - T_e)/(T_i - T_1)] \quad \dots(14)$$

T_1 is the average temperature of the store in the vicinity of the heat exchanger. It may be calculated by measuring the temperature of the store at several points near the heat exchanger and averaging these measurements, or may be measured as the temperature in the store at a point level with the midpoint of the heat exchanger. The value of h calculated during each 30 min period is the value of h corresponding to the average temperature in the store during that 30 min period.

7.1.4.4 Measurement of the pressure drop across the heat exchanger

This test is only required for thermosiphon systems. The test should be made using the same heat transfer fluid as is used in the other tests. The fluid should be kept at a constant temperature. For a series of flow rates from 0.017 kg/s to 0.17 kg/s, the pressure at the inlet and outlet of the heat exchanger is measured. Between measurements, the flow rate should be increased by approximately 0.017 kg/s. If the storage unit contains components such as a pump, expansion tank or valves then these should be included in the test. The test should be performed once with the fluid at 20 °C and once with the fluid at 60 °C.

7.1.5 Simulation Model of Store

7.1.5.1 Validation of the store model

Before the simulation model is used to predict the long term performance of the system, it is important to check that the system has been modeled correctly. In order to verify the part of the model dealing with the store, a dynamic test of the storage system should be made. The results of this test can be used to tune the model of the store.

7.1.5.2 Dynamic test of the store

The store should be tested over a period of three days, in the test installation which was used to determine the store characteristics. The heat input to the store from the collector should be simulated using an electric heater. The output from the heater for each time period in the test should be calculated using equation (15).

$$Q_{\text{coll}} = \eta_o AG - a_1 A(T_i + 2.5 - T_a) \quad \dots(15)$$

This equation represents the performance of a collector, with an increase in temperature across the collector of 5 °C, where T_i is the temperature at the outlet from the heat exchanger or store. The collector area A should be 1 m² per 50 litres of store volume. The values of η_o and a_1 used should be typical values for a good collector, for example, 0.8 W/°C and 5.5 W/°C respectively. G and T_a should be taken from the weather data used for the test. The weather data should reflect first a sunny day, then a cloudy day and then a day with no irradiation. The store will therefore go through periods of heating and cooling. A new value of coll should be calculated every 10 min during test, using the weather data for the beginning of the 10 min period. The energy supplied by the heater should be kept constant over the 10 min period. Hot water consumption should be simulated by drawing-off

hot water several times a day. The draw off rate off hot water several times a day. The draw off rate should be about 10 litre/min. The tank should be refilled with cold water. During the tests the measurements listed in [Table 5](#) should be made.

In addition the measurements listed below should be made every 20 s while hot water is being drawn-off.

- a) Temperature of hot water drawn-off;
- b) Temperature of cold water entering the store;
- c) Temperature difference between hot and cold water; and
- d) Hot water draw-off rate.

All the measurements should be made in accordance with the recommendations in [6](#).

7.1.5.3 Tuning of the store model

The store model should be used to predict the performance of the store using the same heat input from the collector, and same hot water draw-off pattern as in the dynamic test of the store. The values of the parameters determined in the store tests described in [7.1.4](#) should be used in the model. In addition it will be necessary to determine how many layers the store should be divided into in the model and how the overall heat loss coefficient of the store should be distributed among the layers in the store model. It is suggested that the predicted values of energy input to the store, energy output from the store and the predicted hot water draw-off profiles are compared to the measured values and draw-off profiles obtained during the dynamic test. The store model may be considered accurate enough when the predicted values and draw-off profiles agree with the measured values and draw-off profiles within the

Table 5 Measurement to be Made During the Dynamic Test of the Store delete space

([Clause 7.1.5.2](#))

SI No.	Measurement	Frequency of Measurement (Min)
(1)	(2)	(3)
i)	Temperature in the store ¹	10
ii)	Ambient temperature	10
iii)	Temperature of heat transfer fluid at inlet to the store or heat exchanger	1
iv)	Temperature difference of heat transfer fluid at inlet and outlet of the store or heat exchanger	1
v)	Heat transfer fluid flow rate	1

¹ At 4 to 7 levels depending on the height of the store.

uncertainty band of the test measurements. If the predicted results do not agree with the measured results then the number of store layers used in the model, and the distribution of the store heat loss coefficient should be varied until agreement is obtained.

7.2 System Characterization by Testing a Complete Unit (Step 1 Option B)

7.2.1 Introduction

The test method is designed for forced and thermosiphon system with/without auxiliary heater and for ICS system. Basic approach of the method is to characterize system components on the basis of testing the system as a complete unit. The test procedure consists of several separate tests in order to identify system design parameters:

- a) Storage heat loss coefficient test and storage effective capacity test
- b) Test on a complete unit in order to identify:
 - 1) The solar loop heat loss coefficient (solar loop incorporates a collector field, pipings and a heat);
 - 2) Exchanger (if external) for active/thermosiphon systems or complete ICS system;
 - 3) The solar loop optical efficiency;
 - 4) The effective product of the heat exchanger heat transfer coefficient and heat transfer surface area;
 - 5) The storage model (the number of storage layers and their dimensions);
 - 6) The optical efficiency dependence on the part of diffuse irradiation; and
 - 7) Temperature dependence of the heat loss coefficient of solar loop.
- c) Estimation of the parameters:
 - 1) The heat loss coefficient of pipes in solar loop;
 - 2) The collector incident angle modifier/optional; and
 - 3) The pressure drop for solar loop and storage heat exchanger (for thermosiphon system only).
- d) Separate tests for specific types of the system should be carried out as follows:
 - 1) Test to determine a storage model (number of layers and their dimension) for storage with auxiliary heater; and
 - 2) Testing of a control system.

NOTE — Points (3) and (4) of (b), point (c) and point (d) do not concern ICE systems.

Test on a complete unit is the main part of the method consisting of a set of 5 to 8 one-day tests taken independently. Additional 3 to 5 test days are necessary if optional measurements listed in point 'b' are to be identified. The test is based on specific operating conditions selected so as to simplify the mathematical model of the system and so to enable system parameters identification. Namely, the draw-off during active conversation of solar energy (that is the operating period of a collector pump for a forced system) should be held constant during one-day measurement but is different for a set of one-day tests. By identification of the thermal and optimal performance of the system components, a long-term prediction of system performance is enabled for various sets of climatic and operating conditions as well as for certain modifications of the system installation. There is no experimental verification of the applicability of the test method to system with boiling/condensing collectors. The theoretically estimated values of parameters listed in point 'c' could be determined either by experimental procedure described in [7.1](#) for pressure drop measurements or theoretical approximation (calculating the heat losses of the pipes). The test for points (b) and (d) are described in the following [7.2.2](#) and [7.2.3](#).

7.2.2 Test on a Complete Unit

7.2.2.1 Test installation

The considerations outlined in [5](#) and [6](#) should be followed. For testing the ICS and forced/thermosiphon system, a test loop similar to that shown in [Fig. 12](#) and [Fig. 13](#) should be used. The flow controller should be capable of maintaining the flow-rate through the storage at 2.5 percent relative stability. The temperature regulator should be able to control the inlet fluid temperature within 0.2 °C when the flow rate is 600 l/h.

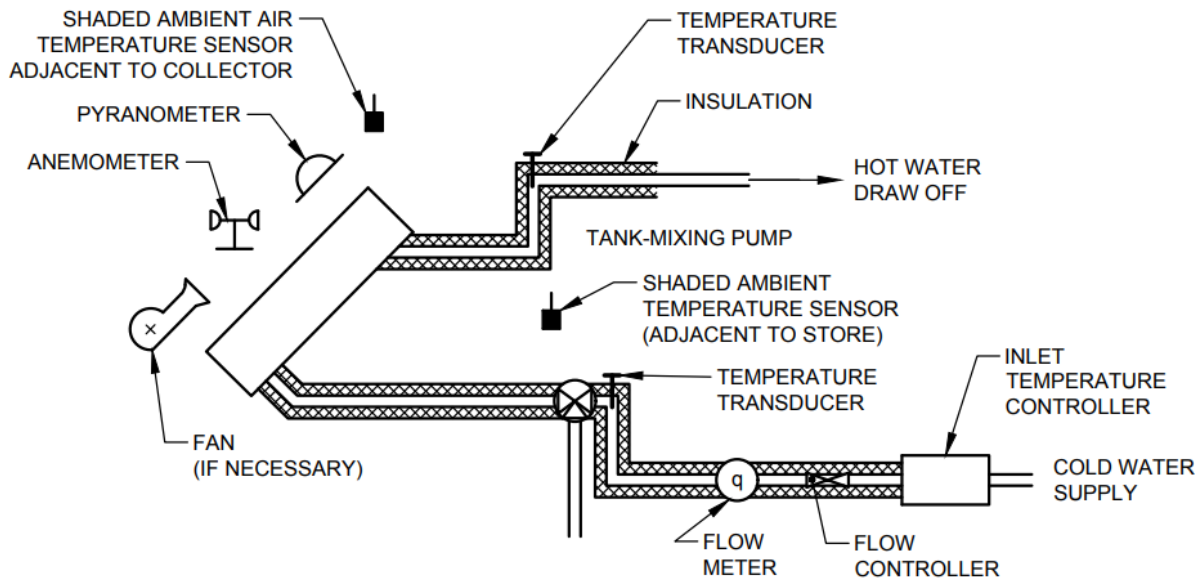

FIG. 12 TEST LOOP FOR THE FORCED/THERMOSIPHON SYSTEM TEST

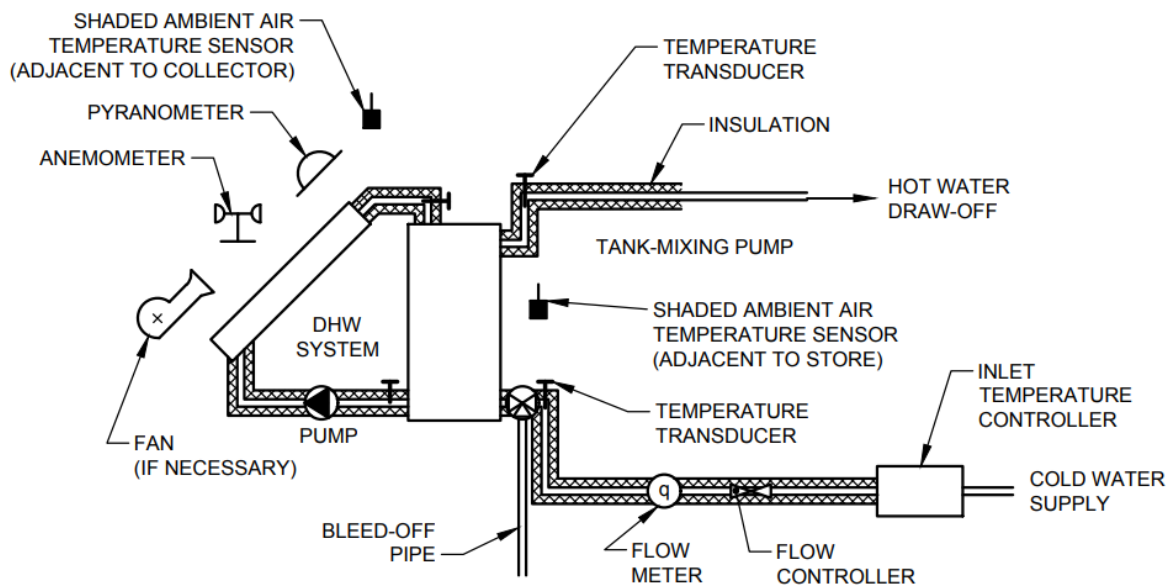

FIG. 13 TEST LOOP FOR THE ICS SYSTEM TEST

7.2.2.2 Preconditioning of the system

After routine inspection of the system and cleaning collector cover, a particular demand flow-rate and reference (that is, mains) temperature should be selected. The demand flow-rate and reference temperature are to be selected in accordance with the next paragraph. The controller (if any) should be disabled and the auxiliary heater turned off. A particular continuous flow-rate should be applied several hours ahead in order to bring the system at uniform temperature. During preconditioning, the collector field should be shielded and the collector

pump, if present, turned on manually. The system may be considered to have reached a uniform temperature if the difference in the temperatures at storage outlet and that at the inlet is less than 0.5 °C.

7.2.2.3 Test conditions and test procedure

The test starts by displacing the collector shield if the following conditions are fulfilled:

- a) Minimum irradiance, G_{Min} , on collector plane should be : $G_{Min} \geq 20 (T_{ci} - T_a)$; and
- b) The incident angle, θ should be: $\theta \leq 35^\circ$.

The operating conditions outlined in previous section should remain the same. It should be noticed that the first part of the test is carried out during the collector active conversion. For thermosiphon and ICS systems, it is assumed, that the time collector field is being not covered is the time of active conversion. The test may be carried out for the days with minimum irradiation during operating period of 9 MJ/m² and for the days with diffuse part of irradiation not higher than 40 percent. It is recommended that a daily test should be taken symmetrically over the solar noon, if possible. Data listed in [Table 6](#) are to be monitored during the first part of measurement. Data necessary for identification of the solar loop parameters are (the mean values are taken over the operating time):

- a) The global irradiation over operating time, H_g ;

$$H_g = \int_{t_1}^{t_2} G dt \quad \dots(16)$$

where

- t_1 = Test starting point; and
 t_2 = Test (first part) stopping point.

- b) The diffuse part of global irradiation, f_d ;
c) The mean surrounding air temperature in vicinity of collector, \bar{T}_{ce} ;
d) The mean surrounding air temperature in vicinity of the storage, \bar{T}_{as} ;
e) The mean solar loop inlet temperature, \bar{T}_{ci} ;
f) The mean reference (mains) temperature, \bar{T}_e ;
g) The demand flow rate, \dot{m}_d ;
h) The integrated temperature differences: and

$$V_{sc} = \int_{t_1}^{t_2} (T_a - T_c) dt = (\bar{T}_a - \bar{T}_c)(t_2 - t_1) \quad \dots(17)$$

$$V_{sc} = \int_{t_1}^{t_2} (T_{as} - T_c) dt = (\bar{T}_{as} - \bar{T}_c)(t_2 - t_1) \quad \dots(18)$$

$$V_{sc} = \int_{t_1}^{t_2} (T_{ac} - T_c) dt = (\bar{T}_{ac} - \bar{T}_c)(t_3 - t_2) \quad \dots(19)$$

$$V_o = \int_{t_1}^{t_2} (T_o - T_c) dt \quad \dots(20)$$

$$V_{o1} = \int_{t_1}^{t_2} (T_o - T_c) dt \quad \dots(21)$$

$$V_{col} = \int_{t_1}^{t_2} (T_{co} - T_{ci}) dt \quad \dots(22)$$

$$V_{cc} = \int_{t_1}^{t_2} (T_{ci} - T_c) dt = (\bar{T}_{ci} - \bar{T}_c)(t_2 - t_1) \quad \dots(23)$$

where

- T_{ci} = The solar loop inlet temperature;
 T_{co} = The solar loop outlet temperature;
 T_o = The storage (demand) outlet temperature; and
 t_3 = The test stopping point.

- j) The mean wind speed on the collector plane, \bar{w} .

The measurements of point (d), point (e) and point (h), equation (18), equation (20), and equation (21) do not concern ICS systems.

The required accuracy of measurement equipment is given in [Table 1](#). The first part of measurement should be terminated if one of the following conditions occurs:

- a) The temperature difference in solar loop ($T_{co} - T_{ci}$) is less than 1°C (for ICS systems $T_o - T_r$, is to be less than 1°C); and
b) Incident angle gets higher than 35°.

If any of these conditions is reached, the collector aperture area should be shielded again the first part of the test is accomplished. The collector pump, if present, should be turned off 5 min (or approximately one time constant of the collector) after collector was shielded. The average wind speed on collector plane should be in the range 3 m/s to 5 m/s during the first part of measurement. Results are to be obtained for minimum five test days for the range of integrated reduced temperature constant, T^* :

- a) Forced systems

$$T^*_i = \frac{\int_{t_1}^{t_2} (T_{ci} - T_a) dt}{H_g} = \frac{\theta_{cc} - \theta_{sc}}{H_g} \quad \dots(24)$$

- b) Forced/Thermosiphon systems

$$T^*_m = \frac{\int_{t_1}^{t_2} (T_{cm} - T_a) dt}{H_g} = \frac{\theta_{col} + 2\theta_{cc} - 2\theta_{se}}{2H_g} \quad \dots(25)$$

where T_{cm} is mean collector temperature
 $[T_{cm} = (T_{co} + T_{ci})/2]$

- c) ICS systems

$$T^*_o = \frac{\int_{t_1}^{t_2} (T_o - T_a) dt}{H_g} = \frac{\theta_o - \theta_{sc}}{H_g} \quad \dots(26)$$

NOTE — For T^* , value data are to be equally distributed, if possible

Minimum value of integrated temperature constant should be selected so as to correspond to $\eta \leq \eta_o/2$ and its maximum value should correspond to $\eta \approx \eta_o$. The value of integrated reduced temperature constant can be influenced either by selecting various reference temperatures or by selecting different demand flow-rates. Measurements should be carried out for a range of demand flow-rates (that is, 4 litre/min, 5 litre/min to 5.5 litre/min, 9 litre/min to 11 litre/min and 13 litre/min to 16 litre/min) for forced/thermosiphon systems. ICS systems should be tested at an approximately same demand flow rate each day. Relative standard deviations of the solar loop parameters should not exceed:

- a) 3 percent for the optical efficiency; and
- b) 10 percent for the heat loss coefficient.

If these limits are exceeded, it is recommended to identify the temperature dependence of the heat loss coefficient and/or dependence of the optical efficiency on diffuse irradiation. In order to identify above dependences, additional tests should be carried out. Extension of the test is carried out by additional measurements on 3 to 5 test days with higher percentage of diffuse irradiation during operating period. The part of diffuse irradiation, f_d , should be:

$$f_d = (50 \pm 10) \text{ percent (1 to 2 points)}$$

$$f_d \geq 70 \text{ percent (2 to 3 points)}$$

It can be assumed that by these tests (8 to 13 daily tests) a range of temperature difference between the mean collector temperature and the ambient temperature (averaged over operating period) is scaled. So, the temperature dependence of the collector heat loss coefficient can be identified as outlined in [7.2.4](#).

If the range of these averaged temperature differences is not sufficient, additional test points should be performed by selecting an appropriate reference temperature(s). Under the operation conditions applied in the test it can be reasonably assumed that store behaves as a countercurrent

heat exchanger. Hence, the heat exchanger theory can be applied. In that sense, the instantaneous data for temperatures c_i , c_o , o and c should be taken. Measurement should be carried out during quasi steady state conditions only.

Quasi steady state condition is assumed to be reached if the above temperatures do not vary more than 0.2 °C for at least 15 min. If the heat exchanger is situated in the top layer, then one-day measurement should be carried out with demand flow capacity lower than collector flow capacity in order to identify the heat exchanger effectiveness as outlined in [7.2.4](#). If external heat exchanger is present, the four clamp-on Pt-100 sensors should be mounted near to the exchanger inlets and outlets. There should be at least six measurement points for heat exchanger effectiveness during daily test. After shielding the collectors the demand flow-rate should be continued, preferably with a higher flowrates, in order to measure heat content in the storage (with respect to the reference temperature). This, second part of test is completed at the moment (noted as t_3) when the temperature difference of the temperatures at the outlet and inlet of the demand loop is less than 0.5 °C. Heat content of the storage could be measured by drawing off the storage water through bleed-off pipe as well.

7.2.3 An Additional Test for a Storage with Internal Heater

7.2.3.1 Preconditioning

The procedure is similar to that described in [7.2.2](#). The whole system has to be brought to the uniform, reference temperature during preconditioning period. In this period the collector should be shielded and collector pump if present, turned on. The system should be checked by a routine procedure.

7.2.3.2 Test procedure

After system has reached uniform temperature the collector shield is to be displaced, demand flow-rate stopped and measurement can start. System should operate from this point as in normal operating conditions (that is for the system with internal heater, the heater will be turned on by the controller). The test should last at least 3 days which can be taken independently with the same initial temperature in the storage but the various flow-rates

each day. The daily irradiation should exceed 12 MJ/m²/day. Continuous demand flow-rate should be applied from 11 a.m. to 1 p.m. each day. A range of flow rates should be applied: preferably 4 l/min to 6 litre/min, 9 litre/min to 11 litre/min and 13 litre/min to 16 litre/min. These measurements (along with meteorological measurements) should be carried out:

- a) The electrical energy supplied by the heater;
- b) The heat extracted from the storage during draw-off; and
- c) The carry-over energy in the storage the following morning.

These data are to be used for determining the number of layers and their dimension by comparison with computer simulation data (using previously identified parameters).

7.2.4 Identification Procedure

The test data should be used only for identification of parameters of a system under the test. The parameters to be identified are the optical efficiency and overall heat loss coefficient of a solar loop. The solar loop parameters may be determined by the least square fitting method. The mathematical model can be presented as a linear function of the parameters which are to be identified. This makes identification procedure extremely simple. It should be pointed out that parameters T^* and η (representing efficiency of solar loop) contain measurable quantities only. The models for identification are following:

- a) Forced system

$$\eta_i = AF_R\eta_o - T^*_i AF_R U_L \quad \dots(27)$$

where

$$\eta_i = \frac{Q_o + Q_{sop} + A_s U_s (\alpha \theta_o - \theta_{sc})}{H_g} \quad \dots(28)$$

- b) Forced/Thermosiphon system

$$\eta_m = AF_m\eta_o - T^*_m F_m U_L \quad \dots(29)$$

where

$$\eta_m = \frac{Q_o + Q_{sop} + A_s U_s (\alpha \theta_o - \theta_{sc})}{H_g} \quad \dots(30)$$

- iii) ICS system

$$\eta_{ics} = AF_o\eta_o - T^*_o AF_o U_L \quad \dots(31)$$

where

$$\eta_{ics} = \frac{Q_c + Q_{sop}}{H_g} \quad \dots(32)$$

where

Q_o = Heat extracted from the storage during operating period:

$$Q_o = \dot{m}_{dc} \int_{t_1}^{t_2} (T_o - T_c) dt = \dot{m}_{dc} \theta_o \quad \dots (33)$$

Q_{sop} = Carry-over energy into the storage at the moment t_z :

$$Q_{sop} = (A_s U_s + \dot{m}_{d2} c) \theta_{o1} - A_s U_s \theta_{sc1} + \Delta Q \quad \dots(34)$$

ΔQ = Correction in heat balance due to the difference between initial and final temperature condition of the storage.

Correction in heat balance is approximated by the equation:

$$\Delta Q = \frac{m_{sc} c}{2} [T_o(t_s) - T_o(t_1)] \quad \dots(35)$$

β = Stratification parameter defined by the equation:

$$\beta = \frac{\theta_{ce}}{\theta_o} \quad \dots(36)$$

α = Stratification parameter approximated by equation:

$$\alpha = \frac{\beta + 1}{2}$$

A = Collector area;

$A_s U_s$ = Storage heat loss coefficient performed by test 1 in 7.2; and

c = Specific heat of heat transfer fluid.

F_R, F_m and F_o are equivalent overall heat removal factors of solar loop regarding inlet, mean, and outlet temperature.

\dot{m}_{d2} is demand flow-rate for time period $t_3 - t_2$

m_s = Storage volume

$T_o(t_3), T_o(t_1)$ = Storage outlet temperatures at the test starting (t_1) and stopping point (t_3)

After that identification, the averaged solar loop flow-rate (\dot{m}_c) for forced/thermosiphon systems should be determined using relationship:

$$\dot{m}_c = \frac{AF_R\eta_o H_g - AF_R U_L (\theta_{ce} - \theta_{se})}{\theta_{col} c} \quad \dots(37)$$

Naturally, equivalent equation can be used with F_m instead of F_R and $0.5 (\bar{T}_{ci} + \bar{T}_{co})$ instead of \bar{T}_{ci} in nominator. After this procedure has been

accomplished, it is recommended to transform all identified values with respect to a mean collector temperature (using F_m values). The next parameter to be identified is the effective product of average overall heat transfer coefficient and heat transfer surface area for a storage with internal heat exchanger. Prior to that identification, heat exchanger effectiveness should be identified. If the collector heat capacity rate is lower than demand heat capacity rate, and if the submerged heat exchanger is situated in a bottom (or middle) layer, exchanger effectiveness may be approximated by the equation:

$$\epsilon = \frac{T_{co}-T_{ci}}{T_{co}-T_c} \quad \dots(38)$$

If demand flow capacity should be lower than collector capacity rate then the heat exchanger effectiveness can be approximated by the equation:

$$\epsilon_q = \frac{T_o-T_c}{T_{co}-T_c} \quad \dots(39)$$

The effective product of average overall heat transfer coefficient and heat transfer surface area has to be calculated for each value of the heat exchanger effectiveness (ϵ) measured during the test (for $\dot{m}_c \leq \dot{m}_d$):

$$(UA)_{exc} = \frac{1-\epsilon \frac{\dot{m}_c c}{\dot{m}_d c}}{\ln \frac{1-\epsilon}{1-\epsilon \frac{\dot{m}_c c}{\dot{m}_d c}}} \cdot \dot{m}_c c \quad \dots(40)$$

If the extension of test 2 in 7.2 has been applied, the identification should be carried out by using the following substitutions in equation (15), equation (28) and equation (31).

Forced/Thermosiphon and ICS systems:

$$\eta_o = \eta_{od} f_d = (1 - f_d) \eta_{ob} \quad \dots(41)$$

Forced/Thermosiphon systems:

$$U_L = U_{Lo} + \gamma [0.5(\bar{T}_{ci} + \bar{T}_{co}) - \bar{T}_a] \quad \dots(42)$$

ICS systems:

$$U_L = U_{Lo} + \gamma [0.5(\bar{T}_o + \bar{T}_c) - \bar{T}_a] \quad \dots(43)$$

The parameters $F_R \eta_{od}$, $F_R \eta_{ob}$, $F_R U_{Lo}$ and $F_{R\gamma}$ or $F_m \eta_{od}$, $F_m \eta_{ob}$, $F_m U_{Lo}$ and $F_{m\gamma}$ or $F_o \eta_{od}$, $F_o \eta_{ob}$, $F_o U_{Lo}$ are to be identified. Apart from optimal values of the parameters, there should be stated the standard deviations of these parameters as well.

The set of data obtained in previous tests should be used in order to determine a storage model by means of detailed simulation programme. Identification of the storage model is performed using the following data:

- a) The above identified parameters;
- b) The operating conditions during the test (demand flow-rate); and
- c) The meteorological parameters (irradiance profile, surrounding air temperature).

The number of layers and their dimension are to be determined with the best fit to the measurement values. Prediction is to be made by the trial and error method by using a range of number of layers with various dimensions with the heat loss distribution corresponding to each storage layer area. The model is considered valid if it predicts the data within the uncertainty band of measurements. The determination of the storage model described here is optional if storage with internal auxiliary heater is considered. In that case, the storage model has to be identified by a similar procedure but with the input data from the test described in 7.2.3. The summarized procedure of the test procedure (option B) is presented in Table 7.

7.3 Establishment of Computer Model and Verification of the Model (Step 2 and Step 3)

The modelling of the system should be carried out using a detailed transient simulation programme in which it is possible to model the different system and storage configurations involved, and in which all the parameters determined in the component tests can be varied.

NOTE — The level of detail needed for most system types is similar to that employed in the models TRNSYS or EMGP2. Guidelines to the type of model needed are given in Annex D.

Before the simulation programme is used to predict the long term performance of the system, it is important to check that the model has been set up to give an accurate representation of the system. This should be done by monitoring the system performance over a range of weather and load conditions and, comparing the measurements made to those predicted by the model for the same weather and load conditions. This verification procedure needs only to be performed once for each type of system. For types of systems for which the simulation model has already been verified once, the monitoring may be considered optional.

Table 6 The Measurement Values During the First Part of the Test*(Clause 7.2.2.3)*

SI No.	Experimental Variable	Integrated Over Time t_1 to t_2 Symbol
(1)	(2)	(3)
i)	Global irradiance, G	H_g
ii)	Diffuse part of irradiance	f_d
iii)	Ambient air temperature in vicinity of collector, T_a	
iv)	Ambient air temperature in vicinity of storage, T_{as}	
v)	Flowrate of cold water supply, m_d	
vi)	Temperature difference at:	
vii)	Outlet and inlet of collector loop, $T_{co} - T_{ci}$	θ_{col}
viii)	Outlet and inlet of demand loop, $T_o - T_c$	θ_o
ix)	Inlet of collector loop and cold water temperature, $T_{ci} - T_c$	θ_{oc}
x)	Collector ambient temperature and cold water temperature, $T_a - T_c$	θ_{ac}
xi)	Storage ambient temperature and cold water temperature, $T_{as} - T_c$	θ_{sc}

NOTE – Measurements of θ_{oc} , θ_{col} , θ_{sc} do not concern ICS systems.

Table 7 The Summarized Procedure of the Test Procedure (Option B)*(Clause 7.2.4)*

SI No.	Procedure	System			
		Forced/Thermosiphon			ICS
		Without Heat Exchanger	Heat Exchanger	Internal Heater	
(1)	(2)	(3)	(4)	(5)	(6)
i)	Testing 7.2.1	Point	Point	Point	Point
a)	Step 1	a	a	a	a
b)	Step 2	b	b	b	b
c)	Step 3	e	e	d	
d)	Step 4			e	
e)	Step I	c	c	c	
ii)	Identification of solar loop parameters 7.2.4	equation	equation	equation	equation
a)	Step 1	29	29	29	31
b)	Step 2	35	35	35	
c)	Step 3		36 to 37		
d)	Step 4		38		
e)	Step I	39	39	39	39
f)	Step II	40	40	40	40
iii)	Identification of storage model 7.2.4	Using detailed simulation programme			

Table 7 (Concluded)

SI No.	Procedure	System				
		Forced/Thermosiphon			ICS	
		Without Heat Exchanger	Heat Exchanger	Internal Heater		
(1)	(2)	(3)	(4)	(5)	(6)	
iv)	Verification of system model 7.3					
			optional		optional	
v)	Prediction of long-term performance 7.4/7.5	Using detailed simulation programme				

7.3.1 Monitoring of the System

7.3.1.1 Option A

The system should be installed as described in 5.5 a tilt angle of 45°. The measurements listed below should be made in accordance with the recommendations of 5 and 6.

- Global irradiance;
- Diffuse irradiance;
- Surrounding air speed;
- Ambient air temperature in region of collector;
- Ambient air temperature in region of store;
- Temperature of heat transfer at collector inlet;
- Temperature of heat transfer fluid at collector outlet;
- Temperature of hot water drawn-off from store;
- Temperature of cold water supplied to store;
- Temperature of heat transfer fluid at store inlet;
- Temperature of heat transfer fluid at store outlet;
- Temperature at control temperature sensor in collector;
- Temperature at a minimum of 6 points in store;
- Flow rate in collector loop;
- Flow-rate of hot water drawn-off; and
- Auxiliary energy use.

The system monitoring period should include:

- A sequence of two sunny days, where the irradiation is greater than 15 MJ/m² per

day, followed by a 'no sun' day. This 'no sun' day may be achieved by covering the collector. During this three day sequence, no hot water should be drawn-off until the end of the third day when a volume of water equal to three times the volume of the storage tank should be drawn off at a rate of 600 l/h; and

- A sunny day with an irradiation of greater than 15 MJ/m² during which water is drawn-off continuously at a rate of about 1.5 l/min per m² of collector area.

7.3.1.2 Option B

The system should be installed as described in 5.5. The measurements listed below should be made in accordance with recommendations of 5 and 6.

- Meteorological measurements (global and diffuse irradiance, surrounding air speed, ambient air temperature in vicinity of storage and collectors);
- Temperature of water drawn-off from store;
- Flow rate of the demand; and
- Auxiliary energy use.

The system monitoring period includes 4 to 7 single day measurements. Except one 'no sun' day, daily irradiation should exceed 12 MJ/m². Measurement procedure is identical to procedure described in 7.2.3 with only difference that real draw off consumption profile(s) should be applied (that is the consumption profile expected to be used in the particular application: with three or more draw-offs during the day/night and/or profile with one evening draw-off, etc).

7.3.2 Tuning of the System Model

The model should be run using the parameters

determined in the component tests and dynamic store test, and the weather and load conditions measured during the monitoring period. It is recommended that the predicted and measured values of the daily energy input to the store, the daily energy output from the store, the maximum temperature reached in the store each day and the hot water draw-off temperature profile are compared. If the values predicted by the model are within the accuracy of the measurements made during the monitoring period, then it can be assumed that the prediction of the long term performance of the system made using the model will be reliable. However, if deviations are observed between the measured and predicted values, then a check must be made for errors in the way the system is installed, the monitoring measurements which were made, the component characteristics which were measured, and the way that the model has been set up. Any errors found should be corrected and the verification process repeated until agreement between the measured and predicted values is obtained.

7.4 Choice of Test Reference Year and Load Data for Yearly Performance (Step 4)

Choice of weather data are to be fixed. The load of the system has also to be fixed accordingly to the typical national consumption.

7.5 Prediction of Long Term Performance (Step 5)

The performance of the system is predicted using a simulation model, which has been verified in accordance with Step 3 and in which the component characteristics are those which were measured in accordance with the procedures given by Step 1. The performance of the system can be predicted for any climate and hot water consumption pattern, but for comparison reasons values are to be fixed in accordance with Step 4. The predicted long term performance should be reported using the format sheets in [Annex E](#).

ANNEX A

(Clause 6.1.4.3)

CALCULATION OF SHADE RING CORRECTION FACTOR

A-1 The reading from a pyranometer with a shade ring should be increased to allow for the region of sky obscured by the ring. The obscured fractions may be found for a ring of radius R , and width w when it is located with its centre at declination δ_o by using the following relations to find A and B :

$$A = R \tan \delta_o - w/2 \quad \dots (A1)$$

$$B = R \tan \delta_o + w/2 \quad \dots (A2)$$

The values of A and B may then be used to define δ_1 and δ_2 , which in turn permit the calculation of s :

$$\sin \delta_1 = A/\sqrt{(R^2 + A^2)} \text{ and } \tan \delta_1 = A/R \quad \dots (A3)$$

$$\sin \delta_2 = B/\sqrt{(R^2 + B^2)} \text{ and } \tan \delta_2 = B/R \quad \dots (A4)$$

For a horizontally placed pyranometer at latitude ϕ ,

$$s(\delta_o) = 1/\pi \left[\sin^{-1}(\sin \delta / \cos \phi) + \sin \delta \sqrt{(\cos^2 \phi - \sin^2 \delta)} - \sin \phi \cos^2 \delta \cos^{-1}(-\tan \phi \tan \delta) \right]_{\delta_1}^{\delta_2} \quad \dots (A5)$$

For a pyranometer mounted at a tilt angle β and pointing south at latitude, ϕ

$$s(\delta_o) = \begin{aligned} & 2/\pi (1 + \cos \beta) \left[\cos \beta \sin^{-1}(\sin \delta / \cos \phi) \right. \\ & \left. + \cos(\phi - \beta)/\cos \phi \sin \delta \sqrt{(\cos^2 \phi - \sin^2 \delta)} - \sin(\phi - \beta) \cos^2 \delta \cos^{-1}(-\tan \phi \tan \delta) \right]_a^b \\ & + 2/\pi (1 + \cos \beta) \left[\sin^{-1} \sin \delta / \cos(\phi - \beta) / + \sin \delta \sqrt{[\cos^2(\phi - \beta) - \sin^2 \delta]} - \sin(\phi - \beta) \right. \\ & \left. \cos^2 \delta \cos^{-1}(-\tan(\phi - \beta) \tan \delta) \right]_c^d \quad \dots (A6) \end{aligned}$$

where the limits are:

if	$\delta_1, \delta_2 \leq 0,$	$a = \delta_1,$	$b = \delta_2,$	$c = 0,$	$d = 0,$
if	$\delta_1 < 0, \delta_2 > 0,$	$a = \delta_1,$	$b = 0,$	$c = 0,$	$d = \delta_2,$
if	$\delta_1, \delta_2 \geq 0,$	$a = 0,$	$b = 0,$	$c = \delta_1,$	$d = \delta_2,$

The reading of the pyranometer is divided by the factor $(1-s)$ to give the corrected value of solar irradiance.

ANNEX B

(Clause 6.3.1)

DENSITY OF WATER

<i>Sl No.</i>	<i>Temperature</i> <i>T (°C)</i>	<i>Density</i> $\rho \times 10^{-3} \text{ (kg/m}^3\text{)}$
(1)	(2)	(3)
i)	5	0.999 9
ii)	10	0.999 7
iii)	15	0.999 0
iv)	20	0.998 2
v)	25	0.997 0
vi)	30	0.995 6
vii)	35	0.994 0
viii)	40	0.992 2
ix)	45	0.990 2
x)	50	0.988 1
xi)	55	0.985 2
xii)	60	0.983 3
xiii)	65	0.980 4
xiv)	70	0.977 5
xv)	75	0.974 7
xvi)	80	0.971 8
xvii)	85	0.969 0
xviii)	90	0.965 3
xix)	95	0.961 5

ANNEX C

(Clause 7.1.1)

RESULT OF COMPONENT CHARACTERIZATION

SYSTEM REFERENCE: _____

TESTS PERFORMED BY: _____

ADDRESS: _____

C-1 DESCRIPTION OF SOLAR DOMESTIC HOT WATER SYSTEM

(PLEASE COMPLETE AS APPLICABLE)

C-1.1 NAME OF SYSTEM AND MANUFACTURER: _____**C-1.2 SERIAL NUMBER OF SYSTEM:** _____**C-1.3 SYSTEM TYPE:** _____

Forced circulation: _____ Thermosiphon: _____ ICS: _____

Boiling/condensing: _____ Other: _____

Close coupled: _____ Separated tank and collector: _____

C-1.4 PRIMARY HEAT TRANSFER FLUID

Water: _____ Oil: _____ Freon: _____

Other: _____

C-1.5 ANTIFREEZE PROTECTION

Type: _____

C-1.6 COLLECTOR

Collector type: _____

Collector aperture dimensions (or tube length): _____

Number of tubes: _____ Tube diameter: _____

Tube pitch:

* Collector ETA Zero $\eta_o = F'(\tau\alpha)_{en} =$ _____ or $\eta_o = F'F'' \cdot (\tau\alpha)_{en} =$ _____* Collector loss coefficient $a_1 = F'U_L =$ _____ or $a_1 = F'F'' \cdot U_L =$ _____Collector flow-rate under test $\dot{m} =$ _____ kg/s

Test laboratory providing this data: _____

* (If known from previous tests — see [7.1.2.1](#))

C-1.7 STORAGE TANK

Manufacturer: _____

Type: _____

Tank dimensions: _____

Tank volume: _____

Material used to insulate Tank: _____

Thickness of Insulation: _____

C-1.8 PUMP

Manufacturer: _____

Type: _____

Power consumption: _____ W

C-1.9 CONTROLLER

Type: _____

C-1.10 AUXILIARY HEATER

Rating: _____ kW, Thermostat setting: _____ °C

Comments on time control of heater: _____

C-1.11 COMMENTS ON SYSTEM DESIGN

C-1.12 SCHEMATIC DIAGRAM OF SYSTEM

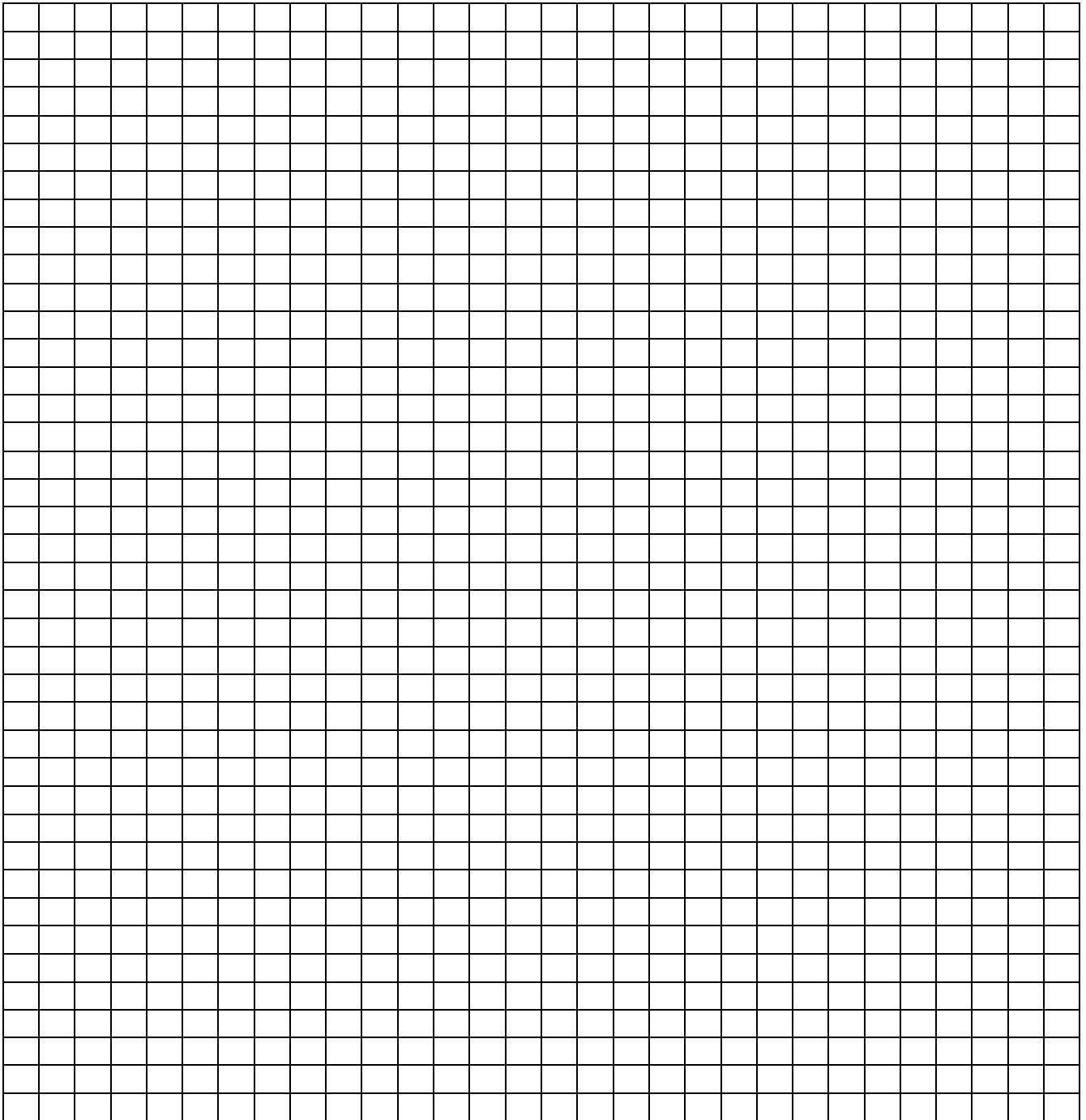

C-2 SYSTEM PERFORMANCE

C-2.1 METHOD

COMPONENT TEST: _____ SYSTEM TEST: _____

Option A

Option B

OTHER: _____

C-2.2 SCHEMATIC DIAGRAM OF TEST LOOP

C-2.3 PHOTOGRAPH OF SYSTEM TEST RIG

C-2.4 TEST INSTALLATION

Piping supplied by: Manufacturer: _____

Laboratory: _____

Distance between the collector and tank: _____

Connecting pipe length: _____ (m) Pipe diameter: _____ (mm)

Pipe insulation material: _____ Thickness: _____ (mm)

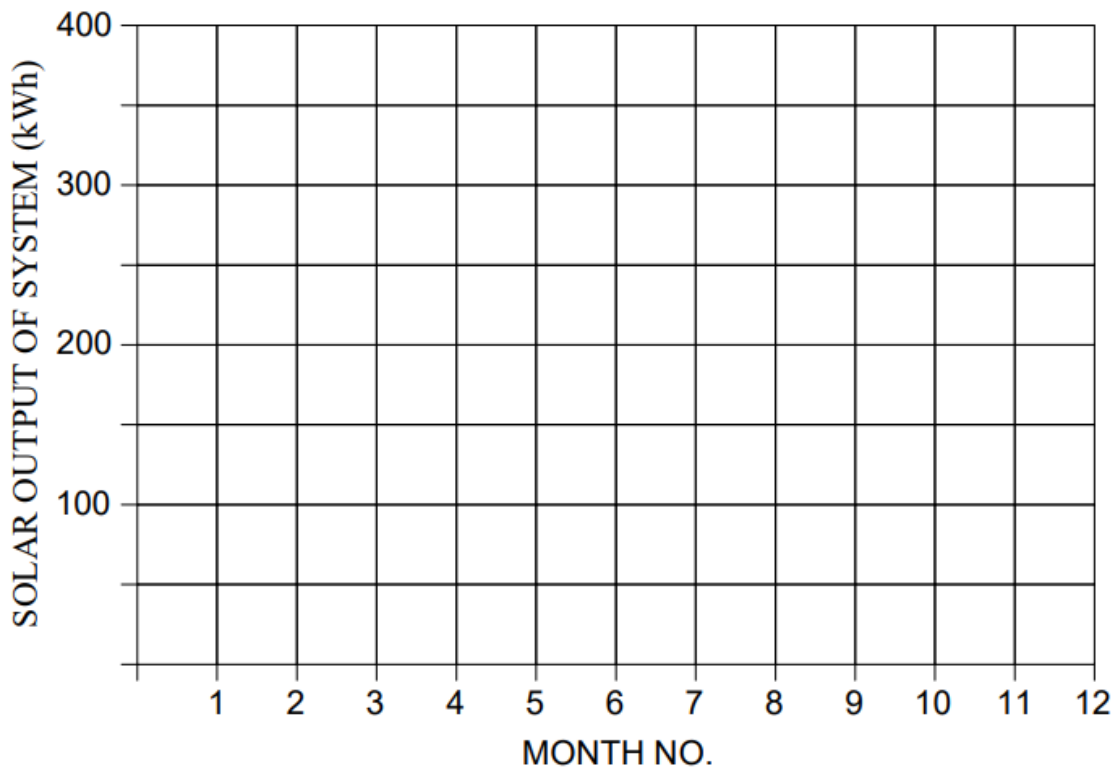

C-3 STORAGE HEAT LOSSES

Tick as appropriate

_____ Indoor

_____ Outdoor

_____ Collector loop connected (recommended test)

_____ Collector loop disconnected (optional)

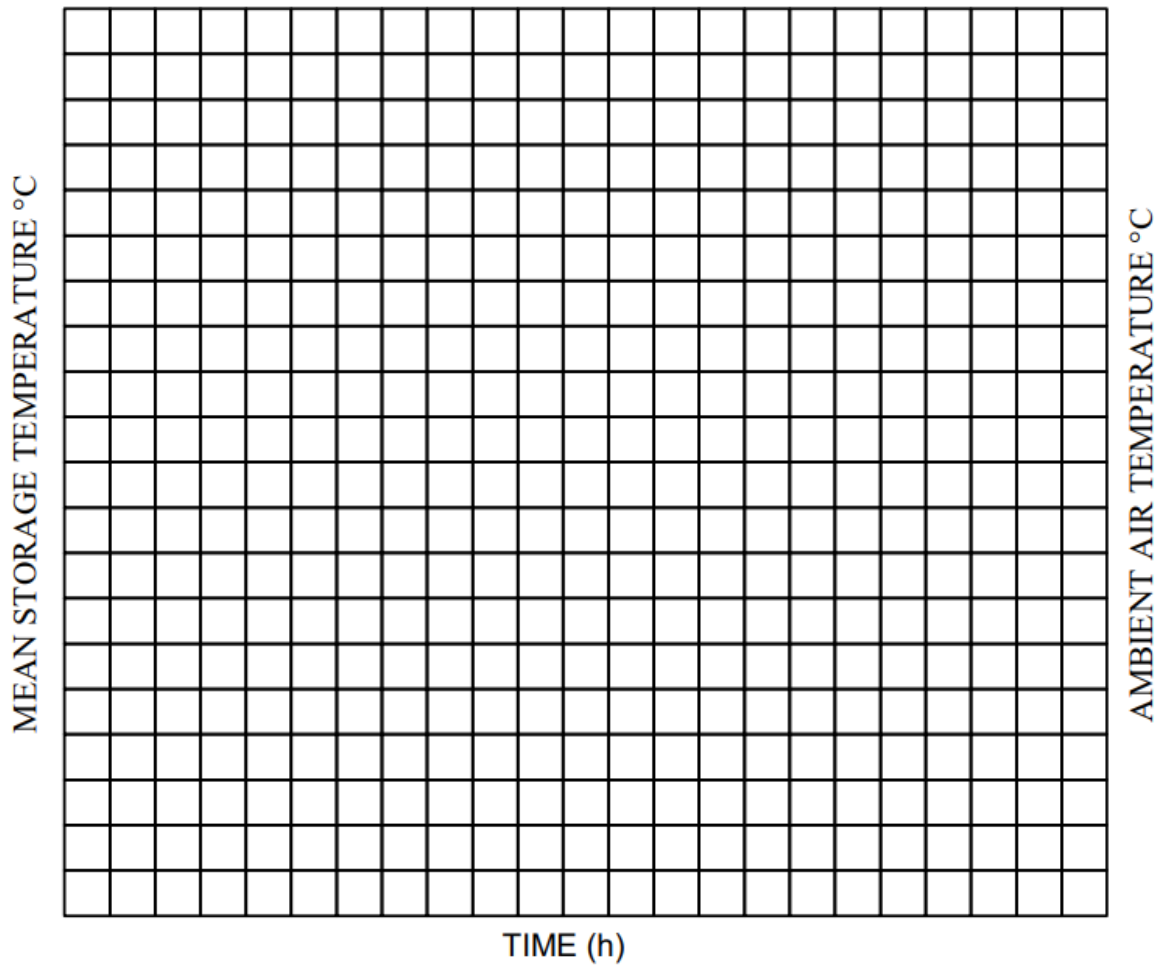

$$U_s = C \ln [T_s (\text{final}) - T_a (\text{av})] / [T_s (\text{initial}) - T_a (\text{av})] / \Delta t$$

Tank capacity (C) _____ J/°C

Initial average temperature of water in tank T_s (initial) _____ °C (measured)

Final average temperature of water in tank T_s (final) _____ °C calculated after equation (6).

Average ambient temperature during test T_a (av) _____ °C

Average wind speed: over collector _____ m/s

over tank _____ m/s

NOTE — Wind speeds should lie between 3 and 8 m/s.

Duration of test Δt _____ s

Deduced value of mean storage heat loss coefficient (U_s) _____ W/°C
calculated after equation (5).

C-4 DRAW-OFF TEMPERATURE PROFILE

IS 13129 (Part 3) : 2024

Draw-off flow rate _____ l/h

Tank volume _____ l

Cold water supply temperature T_c _____ °C

Daily irradiation in plane of collector _____ MJ/m²

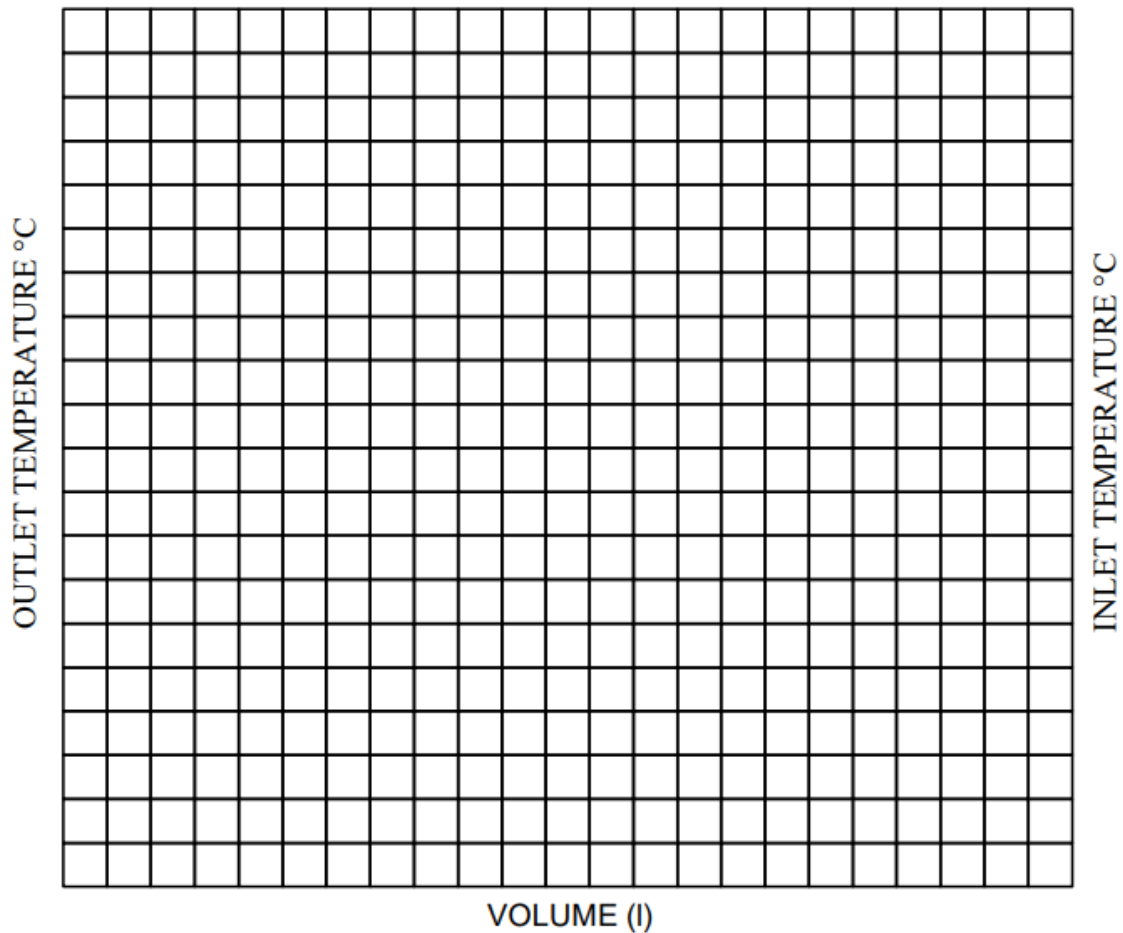

Comments:

C-5 INSTRUMENT AND CALIBRATION

C-5.1 RADIATION MEASUREMENT

Instrumentation: _____

Date of last calibration: _____

Institution providing the calibration: _____

Are the results temperature compensated? _____

Are the results corrected for tilt? _____

Accuracy of alignment to plane of collector \pm _____ °C

Overall accuracy of radiation measurements data \pm _____ %

C-5.2 AMBIENT TEMPERATURE (T_a)

Instrumentation: _____

Date of last calibration: _____

Method of calibration (reference instrument, procedure, etc) _____

Overall accuracy of water outlet temperature \pm _____ °C

C-5.3 STORE INLET WATER TEMPERATURE (T_c)

Instrumentation: _____

Method of calibration (reference instrument, procedure, etc) _____

Overall accuracy of ambient temperature data \pm _____ °C

C-5.4 STORE INLET TEMPERATURE CONTROL

Instrumentation: _____

Stability: _____ \pm _____ °C/h

C-5.5 STORE OUTLET WATER TEMPERATURE

Instrumentation: _____

Date of last calibration: _____

Method of calibration (reference instrument, procedure, etc): _____

Overall accuracy of water outlet temperature: \pm _____ °C

C-5.6 OUTLET FLOW CONTROLLER

Instrumentation: _____

Date of last calibration: _____

Method of calibration (accuracy, etc): _____

Overall accuracy of flow rate controller: \pm _____ °C

C-5.7 SURROUNDING AIR SPEED (u)

Instrumentation: _____

Date of last calibration: _____

Method of calibration: _____

Method of measurement: _____

Artificial wind direction: _____

Overall accuracy of wind data: ± _____ m/s

C-5.8 SOLAR SIMULATION

Lamp type: _____

Excess thermal radiation: _____

Corrections applied: _____

Beam incidence angles: _____

Corrections applied: _____

Comments: (uniformity, etc): _____

C-6 NOMENCLATURE

<i>Sl No.</i>	<i>Symbol</i>	<i>Meaning</i>	<i>Units</i>
(1)	(2)	(3)	(4)
i)	H	Solar irradiation at collector aperture	MJ/m ² .day
ii)	H_d	Diffuse solar irradiation	MJ/m ² .day
iii)	Q	Useful energy extracted from system	MJ
iv)	T_a	Ambient air temperature	°C
v)	$T_a(av)$	Average ambient air temperature	°C
vi)	T_c	Store inlet temperature	°C
vii)	T_i	Initial temperature	°C
viii)	T_f	Final temperature	°C
ix)	Δt	Duration of test	s
x)	u_s	Surrounding air speed	m/s
xi)	U_s	Store heat loss coefficient	W/°C
xii)	V	Storage tank volume	l

ANNEX D

(Clause 7.3)

SYSTEM SIMULATION MODEL

D-1 INTRODUCTION

The model used to simulate the system and predict its long term performance should be detailed, transient model in which all the parameters determined in the component tests can be varied.

D-2 NOMENCLATURE

The nomenclature used in this Annex is as far as possible consist with the nomenclature used in the rest of the document. A list of all the symbols used is given below:

SI No.	Symbol	Meaning	Units
(1)	(2)	(3)	(4)
i)	A_c	Collector surface area	m^2
ii)	A_{exch}	Heat transfer surface area of heat exchanger	m^2
iii)	c_p	Specific heat capacity	J/kgK
iv)	C_c	Thermal capacity of the collector per unit surface area (including the collector fluid thermal capacity)	$J/m^2\text{°C}$
v)	C_s	Thermal capacity of the water in the store per unit volume	$J/m^3\text{°C}$
vi)	F'	Collector efficiency factor	—
vii)	G	Solar irradiance in the collector plane	W/m^2
viii)	h	Heat transfer coefficient	W/m^2
ix)	h_{exch}	Average overall heat transfer coefficient of heat exchanger	$W/m^2\text{°C}$
x)	h_p	Total heat transfer coefficient to a submerged preheating tank	$W/\text{°C}$
xi)	K_{eff}	Effective heat conductivity coefficient	$W/m\text{°C}$
xii)	L	Height of layer in storage tank	m
xiii)	L_{pipe}	Length of piping	m
xiv)	n	Number of ways in which energy is supplied and extracted by directly connected fluid flows or by a submerged heat exchanger	—
xv)	\dot{Q}_{aux}	Power supplied by an auxiliary heater	W
xvi)	\dot{Q}_d	Net power in hot water drawn off from the system	W
xvii)	\dot{Q}_{pump}	Power of circulation pump	W
xviii)	\dot{Q}_p	Power supplied by preheating system during a draw-off hot water	W
xix)	r	Ratio of tank height to tank diameter	—
xx)	T	Instantaneous temperature of collector; Instantaneous temperature of store	°C
xxi)	T_a	Ambient temperature	°C
xxii)	T_{aux}	Temperature of auxiliary tank	°C
xxiii)	T_c	Cold water temperature	°C
xxiv)	T_h	Hot water demand temperature	°C
xxv)	T_{in}	Fluid inlet temperature	°C
xxvi)	T_s	Temperature of fluid in store surrounding heat exchanger	°C
xxvii)	T_{∞}	Outdoor ambient temperature (supplied by meteorological data file)	°C
xxviii)	U_L	Total heat loss coefficient of collector per unit surface area	$W/m^2\text{°C}$

Table (concluded)

Sl No.	Symbol	Meaning	Units
(1)	(2)	(3)	(4)
xxix)	U_{pipe}	Heat loss coefficient per unit length	$\text{W/m}^2\text{°C}$
xxx)	U_s	Total heat loss coefficient of storage	W/°C tank
xxxii)	V_s	Volume of storage tank	m^3
xxxiii)	W	Fluid thermal capacitance flow rate ($W = \eta C_p V$)	W/°C
xxxiv)	W_d	Thermal capacitance flow rate of hot water drawn-off	W/°C
xxxv)	W_{exch}	Fluid thermal capacitance flow rate in the heat exchanger	W/°C
xxxvi)	W_k	Fluid thermal capacitance flow rate in the heat extraction loop or load sub-system	W/°C
xxxvii)	W_p	Thermal capacitance flow rate of water extracted from the pre-heating tank	W/°C
xxxviii)	δw	Fluid flow status variable ($\delta w = 0$ in non-flow conditions, $\delta w = 1$ with fluid flow)	—
xxxix)	γ	Fraction of pump power dissipated in fluid	—
xli)	η	Collector efficiency; Efficiency of heat transfer between the storage tank and a heat supply or heat extraction (for a directly connected fluid flow loop, $\eta = 1$)	—
xlii)	η_{exch}	Heat transfer efficiency of heat exchanger	—
xliii)	Ω	Cross-sectional area of the storage tank	m^2
xliiii)	$(\tau \alpha)$	Average value of the collector transmittance absorptance product	—

D-3 FLAT PLATE COLLECTOR MODEL

The collector, including the collector fluid, is described by a single node model. The collector array is represented by three series connected equal collector segments in order to account for the temperature profile in the flow direction. Each collector segment is described by a differential equation as follows:

$$C_c A_c dT/dt = A_{c\eta} G + \delta w W (T_{\text{in}} - T) \dots (D1)$$

The product ηG is given by:

$$\eta G = F'[(\tau\alpha)G - U_L(T - T_\infty)] \dots (D2)$$

The heat loss coefficient U_L may depend linearly on the temperature difference $(T - T_\infty)$.

$$U_L = U_L + aU_L(T - T_\infty) \dots (D3)$$

D-4 TANK MODELS

D-4.1 Unstratified Tank Model

An unstratified tank model is used to represent the solar energy storage tank, the preheating tank for domestic hot water production and series connected auxiliary tank. The solar storage tank is assumed to be a water tank. The following equation, of which some terms are not applicable to all cases, describes

the tank temperature T :

$$V_s C_s dT/dt = U_s(T - T_a) + \sum_{i=1}^n \delta W_i h_i W_i (T_{\text{ini}} - T) + H_p (T_p - T) + \dot{Q}_{\text{aux}} \dots (D4)$$

Where n refers to the number of ways in which energy is supplied or extracted from the tank, either through a submerged heat exchanger, or by directly connected fluid flows. The subscript, i , refers to the heat exchange loop under consideration. For a directly connected fluid flow loop, the efficiency heat transfer to or from the tank, η_i ; will be 1.

D-4.2 Stratified Tank Model

In the 'stratified models' the collector array is represented by three series connected collector segments and the solar storage tank is described by a stratified tank model with five layers. The model accounts for internal heat conduction between adjacent layers as well as for internal natural circulation whenever a reversed temperature gradient occurs. For systems with a submerged preheating tank in the solar storage, tank or systems with an external preheating tank connected to the solar storage tank by means of a secondary heat transfer loop, the preheating tank is also described by the five layer stratified tank model. The differential equation used to describe each layer of water in the tank is similar to equation (D4) which is used. to describe an unstratified tank, but includes

additional terms to account for heat conduction and water flow between adjacent layers.

$$C_{si} dT_i/dt = -U_{si}(T_i - T_a) + \delta w_{\eta_{exch,i}} W_{exch,i}(T_{ini} - T_i) - h_{ij}(T_i - T_j) + \sum_{k=1}^n W_k(T_{i+1} - T_i) + (\Omega_{kj,i-1,ef})(T_{i-1} - T_i)/L + (\Omega_{kj+1,i,ef})(T_{i+1} - T_i)/L + Q_{aux,i} \dots(D5)$$

The subscript i refers to one layer in the tank, for example, T_i is the temperature in layer i and U_{si} , are the fraction of C_s and U_s which must be attributed to that layer. The layers are each one fifth of the tank volume, so C_{si} is the same for each layer. The total heat loss coefficient for the tank, U_s , is split among the tank layers using the following equations which assume a heat loss coefficient for each layer which is proportional to the outer surface of each layer.

For the top and bottom layer $i = 1$ to 5 and

$$U_{s1} = U_{s5} = U_s(1.25 + r)/(2.5 + 5r) \dots(D6)$$

For the Intermediate layers, $1 = 2, 3$ and 4 and

$$U_{s2} = U_{s3} = U_{s4} = U_{s(r)}/(2.5 + 5r) \dots(D7)$$

The term $h_{ij}, (T_i - T_j)$ in equation (D5) represents the heat transfer from a layer i in the tank to the corresponding layer j of a submerged tank, if it is present. n refers only to the number of directly connected fluid flows. The effective heat conductivity from one layer to the next, $k_{i-1, i, ef}$ or $k_{i, i+1, ef}$, is equal to the heat conduction coefficient of the fluid when $T_i < T_{i-1}$ or $T_{i+1} < T_i$. When a reversed temperature gradient occurs, that is when $T_i > T_{i-1}$ or $T_{i+1} > T_i$, buoyancy forces cause turbulent mixing and the temperatures of both layers rapidly become equal.

D-5 MODEL FOR PIPING ELEMENTS

The piping of all systems, in the collector loop as well as in secondary loops, is described by a steady state equation, that is, the thermal capacity of the piping is neglected. This approximation is used to improve the speed of the computation. When the fluid flow in a piping element is switched on, the steady state value of its outlet temperature is given by:

$$T_{out} = T_{in} e^{U_{pipe} L/W} + [T_a + \gamma Q_{pump}/KL][1 - e^{U_{pipe} L/W}] \dots(D8)$$

For a perfectly insulated pipe, U_{pipe} is 0 and equation (D8) cannot be used. The outlet temperature is then given by:

$$T_{out} = T_{in} + P_{pump}/W \dots(D9)$$

When the fluid flow is switched off, the pipe outlet temperature is not calculated and the piping heat losses are assumed to be zero.

D-6 SUBMERGED HEAT EXCHANGER MODEL

The thermal capacity of a submerged heat exchanger is neglected so that its outlet temperature can readily be calculated from a steady state equation.

$$\eta_{exch} = 1 - \exp(-h_{exch} A_{exch}/W) \dots(D10)$$

$$T_{out} = (i - \eta)T_{in} + \eta T_s \dots(D11)$$

The heat exchanger outlet temperature is only calculated when the fluid flow is switched on. A submerged heat exchanger in a stratified tank is segmented in five series connected parts, submerged in the different layers of the tank. Each segment is characterized by its total heat transfer coefficient and equation (D10) and equation (D11) are applied to each segment. When the heat exchanger does not extend overall layers, the heat transfer coefficient in the other layers is taken as zero.

D-7 MODEL FOR CONTROLLERS

In systems where there is an auxiliary heater either in the main hot water tank or in a separate auxiliary tank, the heating element is switched on and off by a thermostat. A time switch can be included in the on-off control for the auxiliary heater to simulate, for example, a system where the auxiliary heater is run on off-peak electricity. The thermostats and differential thermostats are modelled as on-off controllers, with a hysteresis loop in the switching characteristic.

D-8 MODEL FOR HOT WATER DRAW-OFF SUBSYSTEMS

The distribution of the daily hot water consumption over a 24 h period is specified by the user of the model. Within each hour, the hot water consumption flow rate is taken as constant.

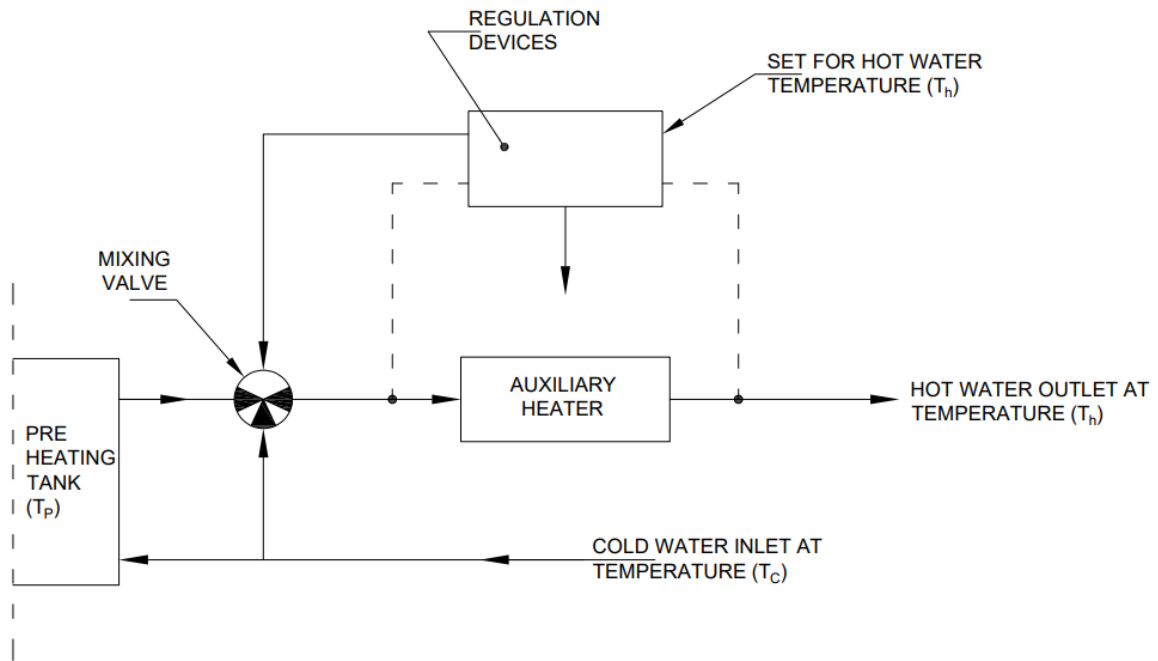

FIG. 14 HOT WATER DRAW-OFF SUBSYSTEM WITH AN AUXILIARY HEATER CONNECTED IN SERIES

The net power of the hot water draw-off is given by:

$$\dot{Q}_d = W_d(T_h - T_c) \quad \dots(D12)$$

The power output of the preheating tank is given by:

$$\dot{Q}_p = W_d(T_p - T_c) \text{ when } T_p < T_h \quad \dots(D13)$$

$$\dot{Q}_p = Q_d \text{ when } T_p > T_h \quad \dots(D14)$$

The power supplied by the auxiliary heater is given by:

$$\dot{Q}_{aux} = \dot{Q}_d - \dot{Q}_s \quad \dots(D15)$$

D-8.1 Hot Water Draw-off Subsystem with an Auxiliary Tank

In this type of system, shown in [Fig. 15](#), a second tank with an auxiliary heater is connected in series with the preheating tank. The auxiliary tank is modelled as an unstratified tank.

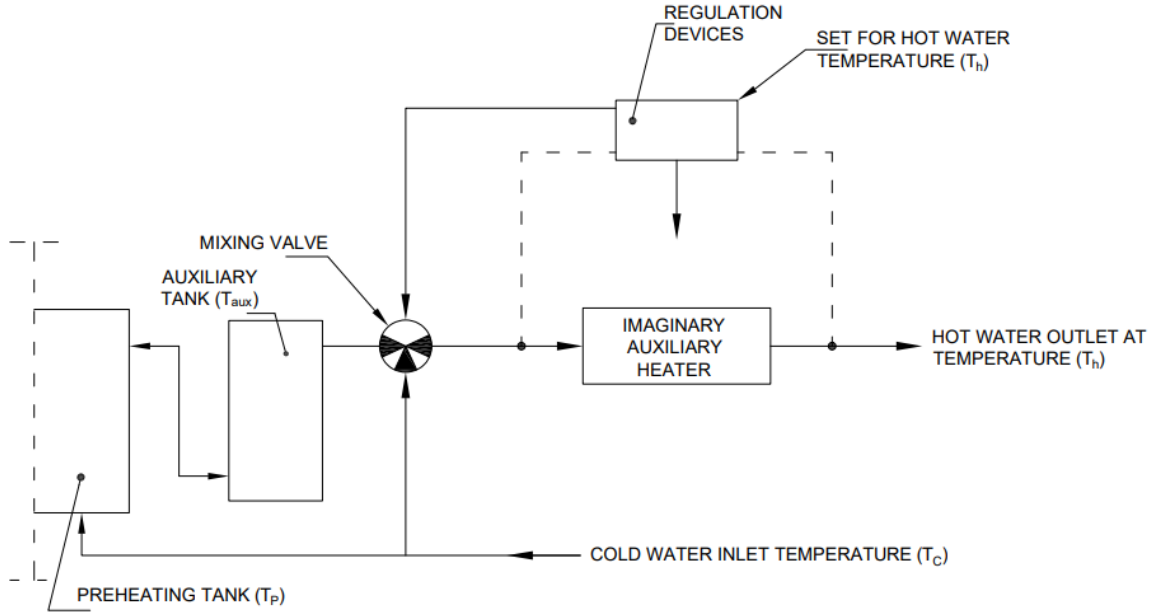

FIG. 15 HOT WATER DRAW-OFF SUBSYSTEM WITH AN AUXILIARY HEATED TANK

The flow rate of the water drawn-off from the tanks is determined by the temperature of the water in the auxiliary tank. The tanks are refilled by cold water entering the preheating tank. The net power of the hot water draw-off is given by equation (D12). The draw-off system is regulated such that the thermal capacitance rate of water extracted from the preheat tank is given by:

$$W_p = W_d \quad \text{when } T_{aux} > T_n \quad \dots(D16)$$

$$W_p = W_d (T_h - T_c) / (T_{aux} - T_c) \quad \text{when } T_{aux} \geq T_h \quad \dots(D17)$$

The power extracted from the preheating tank is given by:

$$\dot{Q}_p = W_p (T_p - T_c) \quad \dots(D18)$$

Accounting for the heat losses of the interconnection pipe between the preheating tank and the auxiliary tank, the auxiliary tank inlet temperature, T_{in} , is given by:

$$T_{in} = T_a (T_p - T_a) \cdot \exp(-U_{pipe} \cdot L_{pipe} / W_p) \quad \dots(D19)$$

The power of the solar energy input to the auxiliary tank, referenced to the cold water inlet temperature T_c and accounting for pipe losses is thus given by:

$$\dot{Q}_1 = W_p (T_{in} - T_c) \quad \dots(D20)$$

and the auxiliary tank power output, also referenced to T_c , is:

$$\dot{Q}_2 = W_p (T_{aux} - T_c) \quad \dots(D21)$$

A system should generally be dimensioned such that the heat demand can be met at all times, that is, $Q_2 = Q_d$. In order to enable the model user to verify that this condition is met, an imaginary, once through auxiliary heater is connected in series to the auxiliary tank at the outlet of the modulation valve. The power supplied by this imaginary heat is calculated and integrated.

$$\dot{Q}_3 = \int \dot{Q}_d - \dot{Q}_2 \quad \dots(D22)$$

ANNEX E

(Clause 7.5)

FORMAT SHEETS FOR THE PRESENTATION OF THE LONG TERM PERFORMANCE PREDICTION

FORMAT SHEETS

LONG TERM PERFORMANCE PREDICTION

SYSTEM REFERENCE: _____

TESTS PERFORMED BY: _____

ADDRESS: _____

1 DESCRIPTION OF SOLAR DOMESTIC HOT WATER SYSTEM

(PLEASE COMPLETE AS APPLICABLE)

1.1 NAME OF SYSTEM AND MANUFACTURER _____

1.2 SERIAL NUMBER OF SYSTEM _____

1.3 SYSTEM TYPE: _____

Forced Circulation: _____ Thermosiphon: _____ ICS: _____

Boiling/condensing: _____ Other: _____

Close coupled: _____ Separated tank and collector: _____

1.4 COLLECTOR

Collector Type: _____

Collector Aperture Dimensions (or tube length): _____

Number of tubes: _____ Tube Diameter: _____

Tube pitch: _____

Collector ETA Zero $\eta_o = F'(\tau\alpha)_{en} =$ _____ or $\eta_o = F' \cdot F''(\tau\alpha)_{en} =$ _____

Collector loss Coefficient $a_1 = F'U_L =$ _____ or $a_1 = F' \cdot F''U_L =$ _____

Collector flow rate under test $\dot{m} =$ _____ kg/s

See 7.1.2.1.

1.5 PIPINGS:

Length: _____

Diameter: _____

Insulation: _____

Thickness of insulation: _____

1.6 HEAT EXCHANGER TYPE:

Submerged: _____

Wrap around: _____

External: _____

1.7 TEST RESULT OF SOLAR LOOP PARAMETERS:

Option A

Editor's note: to be written

Option B

 $\eta_o =$ _____ $F_m U_L =$ _____ $m_c C =$ _____ $(AU)_{exc} =$ _____

Optional

 $F_m \eta_{ob} =$ _____ $F_m U_{Lo} =$ _____ $F_m \eta_{od} =$ _____ $F_m \gamma =$ _____**1.8 STORAGE TANK**

Manufacturer: _____ Type: _____

Tank Volume: _____ (litres) Auxiliary Heater Rating: _____ (kW)

Time periods for which heater is on: _____

1.9 IDENTIFIED STORAGE MODEL

(Simulation programme used, number of layers and their dimensions)

2 LONG TERM PERFORMANCE OF SYSTEM**2.1 PREDICTION METHOD USED**

The used simulation programme has to be specified.

2.2 LOCATION FOR WHICH PREDICTION IS MADE

Place: _____

Latitude: _____

Collector orientation: _____

Collector tilt: _____

2.3 CLIMATIC DATA AND HOT WATER LOAD ASSUMED IN PREDICTION

Reference for climatic data:

Month No.	1	2	3	4	5	6	7	8	9	10	11	12
H_{hor} (MJ/m ²)												
H_{tilt} (°C)												
T_c (°C)												
$T_a(av)$ (°C)												
V_c (l)												
T_h (°C)												

where

- H_{hor} = Monthly average daily irradiation, on a horizontal plane in month;
- H_{tilt} = Monthly average daily irradiation on the collector plane;
- T_c = Monthly average mains water temperature;
- $T_a(av)$ = Monthly average daily ambient temperature;
- V_c = Monthly average daily load; and
- T_h = Hot water demand temperature (if applicable).

Hot water demand profile (if applicable)

SOLAR TIME (h)	1	2	3	4	5	6	7	8	9	10	11	12
percent of consumption volume												

SOLAR TIME (h)	13	14	15	16	17	18	19	20	21	22	23	24
percent of consumption volume												

2.4 PREDICTED SOLAR ENERGY OUTPUT OF SYSTEM

Month No.	1	2	3	4	5	6	7	8	9	10	11	12
kWh												

Annual solar output of system: _____ kWh/year

ANNEX F

(Foreword)

COMMITTEE COMPOSITION

Renewable Energy Sources Sectional Committee, MED 04

<i>Organisation</i>	<i>Representative(s)</i>
Ministry of New and Renewable Energy, New Delhi	DR A. K. TRIPATHI (Chairperson)
Bharat Heavy Electrical Limited, New Delhi	SHRI AMRISH GUPTA
Biogas Forum India, New Delhi	SHRI A. R. SHUKLA
CSIR - Central Leather Research Institute, Chennai	DR P. SHANMUGAM
CSIR - Central Mechanical Engineering Research Institute, Durgapur	DR CHANCHAL LOHA SHRI SUBHO SAMANTA
Cement Manufacturers Association, New Delhi	SHRI RAJU GOYAL SHRI VAIBHAV GUPTA (<i>Alternate I</i>) SHRI MANMOHAN RATHI (<i>Alternate II</i>)
Central Arid Zone Research Institute, Jodhpur	SHRI ANIL KUMAR SINGH DR PRIYABRATA SANTARA(<i>Alternate</i>)
Central Public Works Department, New Delhi	SHRI VIMAL KUMAR SHRI RAJIV GUPTA (<i>Alternate</i>)
Consumer Coordination Council, Noida	SHRI ARUN KUMAR MISHRA SHRI R. K. KAPLASH (<i>Alternate</i>)
Emmvee Photovoltaic Power Private Limited, Bengaluru	SHRI VIJAY KUMAR C. R. SHRI MANJUNATH ULLUR H. (<i>Alternate</i>)
India Meteorological Department, New Delhi	SHRI H. S. SAWHNEY DR ANIKENDER KUMAR (<i>Alternate</i>)
Indian Council of Agricultural Research, New Delhi	DR KANCHAN K. SINGH DR PANNA LAL SINGH(<i>Alternate</i>)
Indian Institute of Technology (BHU), Mechanical Engineering Department, Varanasi	SHRI S. KUMAR SHUKLA
Indian Institute of Technology Bombay, Mumbai	SHRI J. K. NAYAK DR SHIREESH KEDARE (<i>Alternate</i>)
Indian Institute of Technology Delhi, New Delhi	PROF DIBAKAR RAKSHIT PROF K. RAVI KUMAR (<i>Alternate</i>)
Indian Renewable Energy Development Agency Limited, New Delhi	SHRI SOM PAL SHRI S. K. DEY (<i>Alternate</i>)
International Copper Association India, Mumbai	SHRI DEBDAS GOSWAMI SHRI V. K. GUPTA (<i>Alternate</i>)
Maharashtra Energy Development Agency, Pune	SHRI MANOJ A. PISE SHRI HEMANT MANIK (<i>Alternate I</i>) SHRI ANAND V. KULKARNI (<i>Alternate II</i>) SHRI SAMEER GHODAKE (<i>Alternate III</i>)
Ministry of New and Renewable Energy, New Delhi	DR S. R. MEENA DR A. K. SINGHAL (<i>Alternate</i>)
Ministry of Ports, Shipping and Waterways, New Delhi	SHRI ANIL PRUTHI

IS 13129 (Part 3) : 2024

<i>Organisation</i>	<i>Representative(s)</i>
National Institute of Solar Energy, Gurugram	DR CHANDAN BANERJEE SHRI KISHORE K. MENON (<i>Alternate</i>)
Nuetech Solar Systems Private Limited, Bengaluru	SHRI SHRY ANANTH
Rites Limited, Gurugram	SHRI SHRI RUPESH KUMAR SHRI MANISH TIWARI (<i>Alternate</i>)
Rajagiri School of Engineering and Technology, Kochi	DR VARGHESE SHRI JOEL GEORGE (<i>Alternate</i>)
Regional Test Centre, Pune	SHRI PROF SANDESH R. JADKAR DR ANAGHA M. PATHAK (<i>Alternate I</i>) PROF KIRAN DESHPANDE (<i>Alternate II</i>)
Sardar Patel Renewable Energy Research Institute, Mechanical Engineering Department, Vallabh Vidyanagar	SHRI E. R. ASIM KUMAR DR SHAISHAV SHARMA (<i>Alternate</i>)
Solar Thermal Federation of India, Pune	SHRI JAIDEEP N. MALAVIYA
The Energy and Resources Institute, New Delhi	SHRI N. K. RAM
In Personal Capacity (<i>C-103 A, JVTS Garden Chaterpur Extension, New Delhi -110074</i>)	SHRI ATAM KUMAR
BIS Directorate General, New Delhi	SHRI RAJNEESH KHOSLA, SCIENTIST 'F'/SENIOR DIRECTOR AND HEAD (MECHANICAL ENGINEERING) [REPRESENTING DIRECTOR GENERAL (<i>Ex-officio</i>)]

Member Secretary
SHRI AMAN DHANAWAT
SCIENTIST 'B'/ASSISTANT DIRECTOR
(MECHANICAL ENGINEERING), BIS

Bureau of Indian Standards

BIS is a statutory institution established under the *Bureau of Indian Standards Act, 2016* to promote harmonious development of the activities of standardization, marking and quality certification of goods and attending to connected matters in the country.

Copyright

BIS has the copyright of all its publications. No part of these publications may be reproduced in any form without the prior permission in writing of BIS. This does not preclude the free use, in the course of implementing the standard, of necessary details, such as symbols and sizes, type or grade designations. Enquiries relating to copyright be addressed to the Head (Publication & Sales), BIS.

Review of Indian Standards

Amendments are issued to standards as the need arises on the basis of comments. Standards are also reviewed periodically; a standard along with amendments is reaffirmed when such review indicates that no changes are needed; if the review indicates that changes are needed, it is taken up for revision. Users of Indian Standards should ascertain that they are in possession of the latest amendments or edition by referring to the website-www.bis.gov.in or www.standardsbis.in.

This Indian Standard has been developed from Doc No.: MED 04 (21160).

Amendments Issued Since Publication

Amend No.	Date of Issue	Text Affected

BUREAU OF INDIAN STANDARDS

Headquarters:

Manak Bhavan, 9 Bahadur Shah Zafar Marg, New Delhi 110002
Telephones: 2323 0131, 2323 3375, 2323 9402

Website: www.bis.gov.in

Regional Offices:

	Telephones
Central : 601/A, Konnectus Tower -1, 6 th Floor, DMRC Building, Bhavbhuti Marg, New Delhi 110002	{ 2323 7617
Eastern : 8 th Floor, Plot No 7/7 & 7/8, CP Block, Sector V, Salt Lake, Kolkata, West Bengal 700091	{ 2367 0012 2320 9474
Northern : Plot No. 4-A, Sector 27-B, Madhya Marg, Chandigarh 160019	{ 265 9930
Southern : C.I.T. Campus, IV Cross Road, Taramani, Chennai 600113	{ 2254 1442 2254 1216
Western : Plot No. E-9, Road No.-8, MIDC, Andheri (East), Mumbai 400093	{ 2821 8093

Branches : AHMEDABAD. BENGALURU. BHOPAL. BHUBANESHWAR. CHANDIGARH. CHENNAI. COIMBATORE. DEHRADUN. DELHI. FARIDABAD. GHAZIABAD. GUWAHATI. HIMACHAL PRADESH. HUBLI. HYDERABAD. JAIPUR. JAMMU & KASHMIR. JAMSHEDPUR. KOCHI. KOLKATA. LUCKNOW. MADURAI. MUMBAI. NAGPUR. NOIDA. PANIPAT. PATNA. PUNE. RAIPUR. RAJKOT. SURAT. VISAKHAPATNAM.