

रेफ्रिजरेटेड डिस्प्ले कैबिनेट

भाग 2 वर्गीकरण, अपेक्षाएँ और परीक्षण शर्तें

(ISO 23953-2 : 2015, संशोधित)

(पहला पुनरीक्षण)

Refrigerated Display Cabinets

Part 2 Classification, Requirements and
Test Conditions

(ISO 23953-2 : 2015, MOD)

(First Revision)

ICS 27.080; 27.200

© BIS 2024

© ISO 2015



भारतीय मानक ब्यूरो

BUREAU OF INDIAN STANDARDS

मानक भवन, 9 बहादुर शाह ज़फर मार्ग, नई दिल्ली - 110002

MANAK BHAVAN, 9 BAHADUR SHAH ZAFAR MARG
NEW DELHI - 110002

www.bis.gov.in www.standardsbis.in

NATIONAL FOREWORD

This Indian Standard (Part 2) (First Revision) which is modified adoption of ISO 23953-2 : 2015 'Refrigerated Display Cabinets — Part 2 Classification, requirements and test conditions' issued by the International Organization for Standardization (ISO), was adopted by the Bureau of Indian Standards on recommendation of the Refrigeration and Air Conditioning Sectional Committee and approval of the Mechanical Engineering Division council.

This standard was first published in 2017 as IS 16672 (Part 2) : 2017/ISO 23953-2 : 2015 'Refrigerated display cabinets — Part 2: Classification, requirements and test conditions'. This revision has been contemplated to bring it line with ISO 23953-2 : 2015 incorporating the national deviation taking into account the Indian conditions.

After the publication of this standard, IS 1474 : 1959 'Specification for commercial refrigerators' shall be treated as withdrawn.

Under the general title 'Refrigerated display cabinets', the standard is in two parts, other part in this series is as follows:

Part 1 Vocabulary

The text of ISO standard has been approved for publication as Indian Standard with modifications (see [National Annex E](#)). Additionally, certain terminologies and conventions are, however, not identical to those used in Indian Standards. Attention is particularly drawn to the following:

- a) Wherever the words 'International Standard' appears referring to this standard, they should be read as 'Indian Standard'; and
- b) Comma (,) has been used as a decimal marker while in Indian Standards, the current practice is to use a point (.) as the decimal marker.

In this adopted standard, reference appears to certain International Standards for which Indian Standards also exist. The corresponding Indian Standards, which are to be substituted in their respective places, are listed below along with their degree of equivalence for the editions indicated:

<i>International Standard</i>	<i>Corresponding Indian Standard</i>	<i>Degree of Equivalence</i>
ISO 817 Refrigerants — Designation and safety classification	IS 16656 : 2017/ISO 817 : 2014 Refrigerants — Designation and safety classifications	Identical
ISO 5149-2 : 2014 Refrigerating systems and heat pumps — Safety and environmental requirements — Part 2: Design, construction, testing, marking and documentation	IS 16678 (Part 2) : 2018/ISO 5149-2 : 2014 Refrigerating systems and heat pumps — Safety and environmental requirements: Part 2 Design, construction, testing, marking and documentation	Identical
ISO 23953-1 : 2015 Refrigerated display cabinets — Part 1: Vocabulary	IS 16672 (Part 1) : 2017/ISO 23953-1 : 2015 Refrigerated display cabinets: Part 1 Vocabulary	Identical
IEC 60335-1 Household and similar electrical appliances — Safety — Part 1: General requirements	IS 302 (Part 1) : 2008/IEC 60335-1 : 2020 Household and similar electrical appliances — Safety: Part 1 General requirements (<i>seventh revision</i>)	Identical

(Continued on third cover)

Contents

Page

1	Scope	1
2	Normative references	1
3	Terms, definitions, symbols and abbreviated terms	1
3.1	General.....	1
3.2	Compression-type refrigeration systems.....	2
3.3	Indirect refrigeration-type systems.....	3
4	Requirements	3
4.1	Construction.....	3
4.1.1	General.....	3
4.1.2	Materials.....	5
4.1.3	Thermal insulation.....	5
4.1.4	Refrigerating system.....	6
4.1.5	Electrical components.....	6
4.1.6	Temperature display.....	6
4.2	Operating characteristics.....	7
4.2.1	Absence of odour and taste.....	7
4.2.2	Classification according to temperature.....	8
4.2.3	Defrosting.....	8
4.2.4	Water vapour condensation.....	8
4.2.5	Energy consumption.....	8
4.2.6	Specific Energy Consumption.....	9
5	Tests	9
5.1	General.....	9
5.2	Tests outside test room.....	9
5.2.1	Seal test for doors and lids on low temperature applications.....	9
5.2.2	Linear dimensions, areas.....	9
5.3	Tests inside test room.....	10
5.3.1	General conditions.....	10
5.3.2	Preparation of test cabinet and general test procedures.....	19
5.3.3	Temperature test.....	45
5.3.4	Water vapour condensation test.....	50
5.3.5	Electrical energy consumption test.....	51
5.3.6	Heat extraction rate measurement when condensing unit is remote from cabinet.....	51
6	Test report	60
6.1	General.....	60
6.2	Tests outside test room.....	60
6.2.1	Seal test of doors and lids.....	60
6.2.2	Linear dimensions, areas and volumes.....	60
6.2.3	Test for absence of odour and taste.....	61
6.3	Tests inside test room.....	61
6.3.1	General test conditions.....	61
6.3.2	Cabinet preparation.....	61
6.3.3	Temperature test.....	62
6.3.4	Water vapour condensation test.....	62
6.3.5	Electrical energy consumption test.....	63
6.3.6	Heat extraction rate measurement when the condensing unit is remote from the cabinet.....	63
7	Marking	65
7.1	Load limit.....	65
7.2	Marking plate.....	66

7.3 Information to be supplied by the manufacturer.....	66
Annex A (normative) Total display area (TDA)	68
Annex B (informative) Comparison between laboratory and in-store conditions	76
Annex C (informative) Test for absence of odour and taste.....	78
Annex D (normative) Performance and energy rating of commercial refrigerated display cabinets.....	80
Bibliography	89

Indian Standard

REFRIGERATED DISPLAY CABINETS

PART 2 CLASSIFICATION, REQUIREMENTS AND TEST CONDITIONS

(ISO 23953-2 : 2015, MOD)

(First Revision)

1 Scope

This part of ISO 23953 specifies requirements for the construction, characteristics and performance of refrigerated display cabinets used in the sale and display of foodstuffs. It specifies test conditions and methods for checking that the requirements have been satisfied, as well as classification of the cabinets, their marking and the list of their characteristics to be declared by the manufacturer. It is not applicable to refrigerated vending machines. It is also not applicable to cabinets intended for storage or cabinets intended for use, for instance, in catering or non-retail refrigerated applications nor does it cover the choice of the types of foodstuffs chosen to be displayed in the cabinets.

2 Normative references

The following documents, in whole or in part, are normatively referenced in this document and are indispensable for its application. For dated references, only the edition cited applies. For undated references, the latest edition of the referenced document (including any amendments) applies.

ISO 817, *Refrigerants — Designation and safety classification*

ISO 5149-2:2014, *Refrigerating systems and heat pumps — Safety and environmental requirements — Part 2: Design, construction, testing, marking and documentation*

ISO 23953-1:2015, *Refrigerated display cabinets — Part 1: Vocabulary*

IEC 60335-1, *Household and similar electrical appliances - Safety - Part 1: General requirements*

IEC 60335-2-89, *Household and similar electrical appliances - Safety - Part 2-89: Particular requirements for commercial refrigerating appliances with an incorporated or remote refrigerant unit or compressor*

3 Terms, definitions, symbols and abbreviated terms

3.1 General

t_{run}	running time — time during which compressor is running (or solenoid valve is open) or secondary refrigerant is circulating (or solenoid valve is open), within 24 h, expressed in hours
t_{stop}	stopping time — time during which compressor is not running (or solenoid valve is closed) or secondary refrigerant is not circulating (or solenoid valve is closed), within 24 h and excluding defrost time, expressed in hours
t_{defst}	defrost time — time during defrost during which compressor is not running (or solenoid valve is closed) or secondary refrigerant is generally not circulating, within 24 h, but not considered as stopping time, expressed in hours
q_m	mass flow rate of liquid refrigerant or secondary refrigerant in kilograms per second
Δt	time between two consecutive measuring samples, in hours

N_{\max}	number of measuring samples in 24 hours
n_{deft}	number of defrosts during 24 h
Φ_{24}	heat extraction rate during a whole day excepting defrost time, in kilowatts
$\Phi_{24\text{-deft}}$	heat extraction rate during a whole day excepting defrost time, in kilowatts
DEC	direct daily electrical energy consumption, in kilowatt hours per 24 h period
DECR	revised direct daily electrical energy consumption, in kilowatt hours per 24 h period
REC _{RC}	refrigeration daily electrical energy consumption, in kilowatt hours per 24 h period, for remote cabinet for compression-type refrigerating system
REC _{RI}	refrigeration daily electrical energy consumption, in kilowatt hours per 24 h period, for remote cabinet for indirect refrigerating system
RECR _{RC}	revised refrigeration daily electrical energy consumption, in kilowatt hours per 24 h period, for remote cabinet for compression-type refrigerating system
RECAR _{RC}	additional refrigeration daily electrical energy consumption, in kilowatt hours per 24 h period, for remote cabinet for compression-type refrigerating system
RECR _{RI}	revised refrigeration daily electrical energy consumption, in kilowatt hours per 24 h period, for remote cabinet for indirect refrigerating system
RECA _{RI}	additional refrigeration daily electrical energy consumption, in kilowatt hours per 24 h period, for remote cabinet for indirect refrigerating system
TEC	total daily electrical energy consumption in kilowatt hours per 24 h period
TECR	total revised daily electrical energy consumption in kilowatt hours per 24 h period
TDA	total display area, in square meters (see Annex A)
SEC	TEC/TDA Specific Daily Electrical Energy Consumption (SEC) for Refrigerated Display Cabinet expressed in kilowatt hours per 24h per square meters
t_{rr}	relative or percentage running time:

$$t_{\text{rr}} = \frac{t_{\text{run}}}{t_{\text{run}} + t_{\text{stop}}} = \frac{t_{\text{run}}}{24 - t_{\text{deft}}}$$

where

$$t_{\text{run}} + t_{\text{stop}} + t_{\text{deft}} = 24\text{h}$$

Φ_n instant heat extraction rate in kilowatts

3.2 Compression-type refrigeration systems

h_8, h_4	specific enthalpy in kilojoules per kilogram, where state at point 8 corresponds to refrigerant outlet, and state at point 4 to refrigerant inlet, of cabinet
θ_7	refrigerant temperature at evaporator outlet, in degrees Celsius
θ_8	refrigerant temperature at cabinet outlet, in degrees Celsius
θ_4	refrigerant temperature at cabinet inlet, in degrees Celsius

θ_5	refrigerant temperature at evaporator inlet, in degrees Celsius
p_8	refrigerant pressure at cabinet outlet, in Pascals
θ_{mrun}	arithmetic average of evaporator-saturated temperature obtained from pressure p_8 by referring to table of saturation properties for refrigerant in use, during t_{run} , in degrees Celsius
θ_{min}	arithmetic average of evaporator-saturated temperature obtained from pressure p_8 by referring to table of saturation properties for refrigerant in use, during the last 10 % of all running periods, in degrees Celsius
T_{mrun}	$= \theta_{mrun} + 273,15$ in Kelvin

3.3 Indirect refrigeration-type systems

θ_i	secondary refrigerant temperature at cabinet inlet, in degrees Celsius
θ_o	secondary refrigerant temperature at cabinet outlet, in degrees Celsius
θ	secondary refrigerant median temperature, in degrees Celsius $(\theta_i + \theta_o)/2$
θ_{mrun}	arithmetic average of the secondary refrigerant median temperature (θ) during t_{run} , in degrees Celsius
θ_{min}	arithmetic average of the secondary refrigerant median temperature (θ) during last 10 % of all running periods, in degrees Celsius
q_{mrun}	arithmetic average of the secondary refrigerant mass flow during t_{run} , in kilograms per second
c_i	specific heat of secondary refrigerant, in kilojoules per kilogram per degree Celsius at cabinet inlet
c_o	specific heat of the secondary refrigerant, in kilojoules per kilogram per degree Celsius, at cabinet outlet
$p_{irun} - p_{orun}$	pressure drop between inlet and outlet of cabinet during t_{run} , in kilo Pascals
CPEC	pumping electrical energy consumption expressed in kilowatt hours per 24 h period
v	specific volume of secondary refrigerant, in cubic metres per kilogram (simplification: $v = \text{const.} = 0,001 \text{ m}^3/\text{kg}$)

4 Requirements

4.1 Construction

4.1.1 General

4.1.1.1 Strength and rigidity

The cabinet and its parts shall be constructed with adequate strength and rigidity for normal conditions of handling, transport and use. Attention shall be given to the following:

- interior fittings, including shelves, baskets, rails, etc. and their supports, shall be sufficiently strong for the duty required;

- b) where sliding shelves, baskets, trays or drawers are fitted they shall retain their shape and ease of movement when fully loaded;
- c) any fitments which are provided with stops to prevent accidental removal shall be self-supporting when fully loaded and withdrawn to the limit of the stops;
- d) stops.

4.1.1.2 Pipes and connections

Pipes and connections to moving or resiliently mounted parts shall be arranged so as not to foul or transmit harmful vibrations to other parts. All other pipes and connections shall be securely anchored and sufficient free length and/or vibration eliminators shall be provided to prevent failure due to fatigue. Where necessary, pipes and valves shall be adequately thermally insulated.

4.1.1.3 Condensate drainage

Where drains, drip trays or evaporation receptacles are fitted, they shall have ample capacity and shall be easily accessible and cleanable.

Any condensate or defrost water receptacle, or group of receptacles, requiring to be emptied manually shall have a capacity equivalent to at least 48 h of normal operation in the appropriate climate class for which the cabinet is intended.

4.1.1.4 Closed refrigerated cabinets (self-service type)

Closed refrigerated cabinets shall meet certain special requirements as follows.

Hinged lids and doors shall be opened by different angles of at least 60°.

Transparent doors and lids shall be condensate-free at the climate class specified by the manufacturer.

Door fasteners and hinges under normal conditions of use shall be smooth and positive in action and designed to function properly without undue wear.

When any doors or lids provided to ensure an air seal to the refrigerated space are closed, there shall be no undue leakage of ambient air into the interior.

The doors or lids shall not open of their own accord.

The gasket shall be made from a material whose characteristics are compatible with the operating conditions (especially temperatures). If the fastening device is mechanical, a stop or other means shall be provided to prevent the gasket from being excessively deformed.

4.1.1.5 Joints and seams

All construction joints and seams within the net volume shall prevent the accumulation of potentially contaminating substances.

All construction joints and seams within the net volume shall permit the easy removal of any deposits of potentially contaminating substances.

4.1.1.6 Sneeze guard

The front façade constitutes a guard against risks of contamination emanating from consumers through handling, coughing, etc. in case of display and sale of unpacked foodstuffs.

For this, the sum of vertical dimension *A* and horizontal dimension *B* as shown in [Figure 1](#) shall be not less than 1 500 mm.

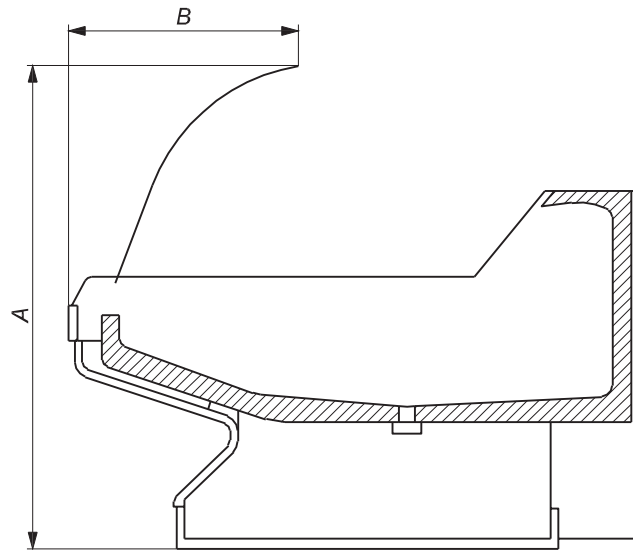
**Key**

A vertical dimension

B horizontal dimension

Figure 1 — Dimensions for sneeze guard**4.1.2 Materials****4.1.2.1 General**

The materials shall be durable and shall not favour the development of mould or emit odours.

Under normal conditions of use, materials in contact with foodstuffs shall be resistant to moisture and shall neither be toxic nor contaminate them.

4.1.2.2 Wear resistance

Internal and external finishes shall be resistant to wear and capable of being cleaned effectively and hygienically. Finishes shall not crack, chip, flake, rub off or soften under normal conditions of use or during cleaning.

4.1.2.3 Corrosion resistance

Metal parts, used in the construction of cabinets, shall have resistance to corrosion appropriate to their location and function.

4.1.3 Thermal insulation**4.1.3.1 Efficiency**

The thermal insulation shall be efficient and permanently fixed. In particular, the insulating material shall not be subject to shrinkage and shall not allow under normal working conditions an accumulation of moisture (see [4.2.4](#)).

4.1.3.2 Vapour barrier

Suitable means shall be used to prevent deterioration of the thermal insulation by the ingress of moisture.

4.1.3.3 Containment of insulation material

Where the insulation space is vented to the inside, it shall be ensured that particles of the insulation material cannot escape into the foodstuff display compartment.

For fibrous insulation materials, it shall not be possible to insert a rigid probe of 1 mm diameter through any aperture which allows access to the insulating material, the probe being applied with negligible force.

4.1.4 Refrigerating system

4.1.4.1 Design and construction

The design and construction of all parts of the refrigerating system subject to internal pressure shall take into account the maximum working pressure to which they are subjected when the cabinet is in operation or at rest.

For refrigerated display cabinets with integral condensing unit or components thereof which are charged with refrigerant prior to transportation, the maximum ambient temperature during transit shall be taken into account. All refrigerant containing components shall be in accordance with ISO 5149-2.

4.1.4.2 Condensation

There shall be suitable means to prevent water condensed on cold surfaces of the cabinet and its parts from harmfully affecting the operation of the refrigerating system or its controls.

4.1.4.3 System protection

For cabinets fitted with doors or lids, the refrigerating system shall suffer no damage if any door or lid in the cabinet is left open while the cabinet is operating in an ambient temperature corresponding to the climate class (see [Table 3](#)) for which the cabinet is intended.

When the door or lid is kept open under normal operating conditions (for example, during product loading) or is left open accidentally, any automatic motor overload protective device may come into operation.

4.1.4.4 Refrigerant

When deciding on the refrigerant for the system, attention shall be given to the possible hazards associated with the use of certain refrigerants and heat-transfer media or secondary refrigerant, due to their toxicity, flammability etc. Guidance on this point is available in ISO 5149-2.

4.1.5 Electrical components

Electrical components shall be in accordance with IEC 60335-2-89 and IEC 60335-1.

4.1.6 Temperature display

The cabinets shall incorporate a temperature display instrument showing the air temperature in the refrigerated display cabinets to provide an indication of the operation and functioning of refrigerating equipment and information on its operating state.

NOTE As a rule, measured air temperature is not identical with foodstuff temperature in refrigerated display cabinets.

4.1.6.1 Temperature-measuring instrument

Suitable temperature-measuring instruments shall be used, i.e. those that fulfil the following requirements:

- the unit symbol (°C or °F) shall be inscribed or displayed on the temperature-measuring instrument;

- the range of measurement shall be at least from -25 °C to $+15\text{ °C}$;
- the scale division or smallest numerical increment shall be less than or equal to 1 °C ;
- the maximum errors shall be 2 K over the total measuring range;
- the time constant t_{90} of the sensor shall be equal to or less than 20 min.

NOTE The t_{90} time is the time in which 90 % of a sudden temperature change of 20 °C is indicated, the measurement medium being moderately agitated air (velocity 1 m/s).

4.1.6.2 Temperature sensor location

The temperature sensor location shall be readily accessible to enable on site testing for the correct indication of temperature and replacement of the temperature measuring instrument on site in service.

NOTE 1 The temperature sensor of a thermometer is considered to be “readily accessible” if it can be reached directly for examination. It may be necessary to remove access panel(s) to carry out replacement.

NOTE 2 For cabinets with natural convection cooling, the positioning of the temperature sensor in a guide tube is also considered to be “readily accessible” if the sensor can be introduced into and removed from the guide tube without a tool.

NOTE 3 For an electronic controller, it is possible to display a calculated temperature.

Wherever possible, the mounting method shall not supply heat to, or withdraw heat from the temperature sensor.

The temperature sensor shall be protected against heat radiation from the external ambient.

The temperature sensor location is defined as part of the temperature test of the refrigerated display cabinet. During the temperature test air temperatures at the declared sensor location shall be measured and these values noted in the test report.

NOTE 4 It is the responsibility of the supplier and end user to ensure that the temperature measurements comply with national regulation on temperature control of foodstuffs.

4.1.6.3 Number of temperature-measuring instruments

When temperature measuring instruments are employed in refrigerated display cabinets:

- one temperature measuring instrument shall be employed for each refrigerated display cabinet with its own refrigerating circuit;
- in the case of several refrigerated display cabinets with a common refrigerating circuit operating in one temperature class, a minimum of one temperature measuring instrument shall be employed for maximum two refrigerated display cabinets with a total length of maximum $3,75\text{ m}$;
- in the case of several refrigerated display cabinets with a common refrigerating circuit working in different temperature classes, the above requirement shall be observed, but with separate temperature-measuring instruments employed for each temperature class.

4.2 Operating characteristics

4.2.1 Absence of odour and taste

The absence of odour and taste is not compulsory. An optional test method of is given in [Annex D](#).

4.2.2 Classification according to temperature

The performance of cabinets shall comply with one of the classifications defined in [Table 1](#). The performance shall be verified in accordance with the conditions and test methods specified in [5.3.3](#).

NOTE [Annex B](#) compares laboratory and store condition.

Table 1 — M-package temperature classes

Class	Highest temperature, θ_{ah} , of warmest M-package colder than or equal to ^{ab}	Lowest temperature, θ_b , of coldest M-package warmer than or equal to ^b	Highest minimum temperature, θ_{al} , of all M-package colder than or equal to ^a
	°C		
L1	-15	—	-18
L2	-12	—	-18
L3	-12	—	-15
M0	+4	-1	—
M*	6	-1	—
M1	+5	-1	—
M2	+7	-1	—
H1	+10	+1	—
H2	+10	-1	—
S	Special classification		
a	See Figure 29a		
b	See Figure 29b		
For Class M, the highest temperature of warmest package θ_{ah} colder than or equal to 6,1 °C but the average of the warmest M package colder than or equal to 5 °C			

4.2.3 Defrosting

The accumulation of ice, frost or snow on surfaces within the refrigerated space (excluding the surfaces of the test packages), as well as the accumulation of drained defrost water, shall not occur, as it would impair the performance of cabinets other than those which are intended to be defrosted manually.

The proposed defrosting procedures (automatic or manual) shall not affect the temperature requirements.

For cabinets or parts of cabinets with manual defrosting, the manufacturer shall supply all necessary instructions for the correct operation of the defrosting system.

4.2.4 Water vapour condensation

The performance of cabinets shall not be impaired by water vapour condensation. The amount of water vapour condensation shall be verified according to the conditions and test methods specified in [5.3.4](#).

4.2.5 Energy consumption

The heat extraction rate and the energy consumption shall be stated by the manufacturer.

The direct daily electrical energy consumption (DEC) and, when the condensing unit is remote from the cabinet, the refrigeration daily electrical energy consumption (REC) and total daily energy consumption (TEC) shall be measured and calculated according to the conditions and the test methods specified in [5.3.5](#) and [5.3.6](#).

4.2.6 Specific Energy Consumption

The Cabinet Specific Daily Electrical Energy consumptions SEC as ratio between TEC and TDA shall be stated by the manufacturer; this value, representing the best index for performance evaluation of a commercial refrigerated display cabinet.

5 Tests

5.1 General

When the characteristics of a cabinet are to be verified, all the tests and inspections shall be applied to one and the same cabinet. These tests and inspections may also be made individually for the study of a particular characteristic.

[Table 2](#) lists the tests and inspections. Cabinets shall comply with the requirements specified in this part of ISO 23953 using the appropriate test method.

Table 2 — Test summary

Tests and inspections	Requirement clause in this part of ISO 23953	Test method	
Seal test	4.1	5.2.1	Outside test room (see 5.2)
Physical dimensions of sneeze guard	4.1.1.6	5.2.2	
Absence of odour and taste (not compulsory)	—	Annex C	
Temperature	4.2.2	5.3.3	Inside test room (see 5.3)
Defrosting	4.2.3	5.3.3	
Water vapour condensation	4.2.4	5.3.4	
Energy consumption	4.2.5	5.3.5 and 5.3.6	

5.2 Tests outside test room

The tests which may be carried out outside the test room deal with the inspection of construction characteristics, physical dimensions and the absence of odour and taste.

5.2.1 Seal test for doors and lids on low temperature applications

The effectiveness of doors or lids provided to ensure a seal shall be tested as follows (with the cabinet not running).

Insert a strip of paper 50 mm wide, 0,08 mm thick and of a suitable length at any point of the seal. With the door or lid closed normally on it the strip of paper shall not slide freely.

NOTE 1 Attention is drawn to the fact that some cabinets having doors provided to ensure an air seal are fitted with decompression valves which allow air to penetrate for a short period of time so that any drop in pressure created inside the cabinet may be compensated. No test is required for such valves.

NOTE 2 The most unfavourable points can be found by inspecting the contact of the seal with the cabinet closed and lit from the inside.

5.2.2 Linear dimensions, areas

Measurements shall be made with the cabinet not in operation but situated in a place where the temperature is maintained between 16 °C and 30 °C.

For cabinets having detachable ends, overall dimensions are given with and without ends. If the cabinet includes jacks or other components for adjustment of height, the height defined shall be the minimum height necessary at installation of the cabinet.

The total display area (TDA) shall be calculated according to [Annex A](#).

5.3 Tests inside test room

The tests which are carried out inside the test room deal with the measurement of the following characteristics:

- temperature and defrosting;
- water vapour condensation;
- electrical energy consumption;
- heat extraction rate.

These measurements should be made simultaneously.

5.3.1 General conditions

In the following, general testing conditions which are common for all tests specified in [5.3.3](#) to [5.3.6](#) carried out inside the test room are defined. These conditions concern the test room, the test and M-packages, and the measuring instruments.

5.3.1.1 Test room — General design, walls, floor and radiant heat

The test room shall be a parallelepiped space in which two of the opposite side walls, referred to as the discharge technical side wall and the return technical side wall, are designed to create an even, horizontal air flow within the test room. By convention, the distance separating these two technical side walls is referred to as the “length” of the test room.

The minimum useful dimensions (length, width, height) of the test room shall be dependent on the overall dimensions (length, depth, height) of the cabinet to be tested and on the location of the display opening of the cabinet (see [5.3.2.1](#)).

The ceiling and the two non-technical side walls of the room shall be thermally insulated and shall be equipped with an inner metal skin.

A minimum insulation level equivalent to 60 mm of rigid polyurethane foam ($\lambda = 0,03 \text{ W/m } ^\circ\text{C}$) should be used for the building of a new test room.

The floor shall be made of concrete or of thermally equivalent material and/or shall be sufficiently insulated to ensure that external climatic conditions do not affect the floor temperature.

Fluorescent or led lighting shall be installed to maintain $600 \pm 100 \text{ lx}$ measured at a height of 1 m above the floor level and shall be lit continuously during the test period. The emission spectrum of that lighting device within the infrared field shall not include peaks of a value of more than 500 W/5 nm/lm .

The walls, ceilings and any partitions of rooms intended for the testing of refrigerated display cabinets shall be painted in light grey (for example, NCS 2706-G90Y or RAL 7032) so that the emissivity is between 0,9 and 1 at $25 \text{ }^\circ\text{C}$.

5.3.1.2 Test room (empty) — Thermal and air flow characteristics

An experimental evaluation of the test-room performances shall be carried out minimum once per year

- with test room empty and with lighting switched on,

- in a test-room climate class 3 (see [Table 3](#)),
- measuring the velocity, temperature and relative humidity of the air at different points of two vertical planes parallel to the technical side walls and 600 mm away from the technical side walls, and
- with the climate measuring point located at the geometrical centre of the test room during this evaluation.

These measuring points shall form a two-dimensional grid in which the step is a maximum of 500 mm in the horizontal and vertical directions. The peripheral line of points shall be located at a maximum of 500 mm from the other two side walls, floor and ceiling.

A three-dimensional grid inside the test room shall be investigated when obstacles/irregularities projected into the room of more than 1 m² surface area facing the discharge technical side wall exist along the walls.

The mean horizontal air velocity measured during 1 min with a maximal interval of 5 s at each of the points defined above shall lie between 0,1 m/s and 0,2 m/s.

Air temperature measured at each of the points defined above shall not deviate from the rated temperature of the test-room climate class by more than 2 °C.

The test room shall be capable of maintaining values of humidity within ± 3 units of the relative humidity percentage figures of the rated humidity of the test room temperature class at the specified measuring points.

Surface temperature of walls, ceiling and floor shall be measured in proximity to the points which constitute the peripheral line of the grid defined above. These surface temperatures shall remain within a tolerance of ± 2 °C in relation to the air temperature measured at the nearest point of the grid.

5.3.1.3 Test room climate definition

5.3.1.3.1 Test room climate classes

Tests shall be carried out in one of the climate classes according to [Table 3](#).

During the test, the test room shall be capable of maintaining values of temperature and humidity within ± 1 °C of the temperature and ± 5 units of the relative humidity percentage figures at the specified climate measuring point(s) (see [5.3.1.3.2](#)). The exception to this is test-room climate class 3, for which the tolerance of the relative humidity is instead ± 3 units.

Table 3 — Climate classes

Test room climate class	Dry bulb temperature °C	Relative humidity %	Dew point °C	Water vapour mass in dry air g/kg
0	20	50	9,3	7,3
1	16	80	12,6	9,1
8	24	55	14,4	10,2
2	22	65	15,2	10,8
3	25	60	16,7	12,0
4	30	55	20,0	14,8
6	27	70	21,1	15,8
5	40	40	23,9	18,8

NOTE The water vapour mass in dry air is one of the main points influencing the performance and the energy consumption of the cabinets. Therefore the order of the climate class in the table is based on the water vapour mass column. See also [Annex B](#) to compare lab and store conditions.

Table 3 (continued)

Test room climate class	Dry bulb temperature °C	Relative humidity %	Dew point °C	Water vapour mass in dry air g/kg
7	35	75	30,0	27,3

NOTE The water vapour mass in dry air is one of the main points influencing the performance and the energy consumption of the cabinets. Therefore the order of the climate class in the table is based on the water vapour mass column. See also [Annex B](#) to compare lab and store conditions.

5.3.1.3.2 Climate measuring point

The point for measurement of ambient temperature and relative humidity shall be midway along the length of the cabinet and in accordance with [Figures 2](#) to [5](#).

In the case of typical island cabinets, and island with air discharge in the middle, temperatures shall be taken at both sides [see [Figure 3](#) a), b), c)].

For plug-in cabinets, the warm condenser air flow shall be prevented from influencing the temperature at the measuring point by air deflectors or other suitable means (see [5.3.2.1](#), [Figure 9](#)).

Dimensions in millimetres

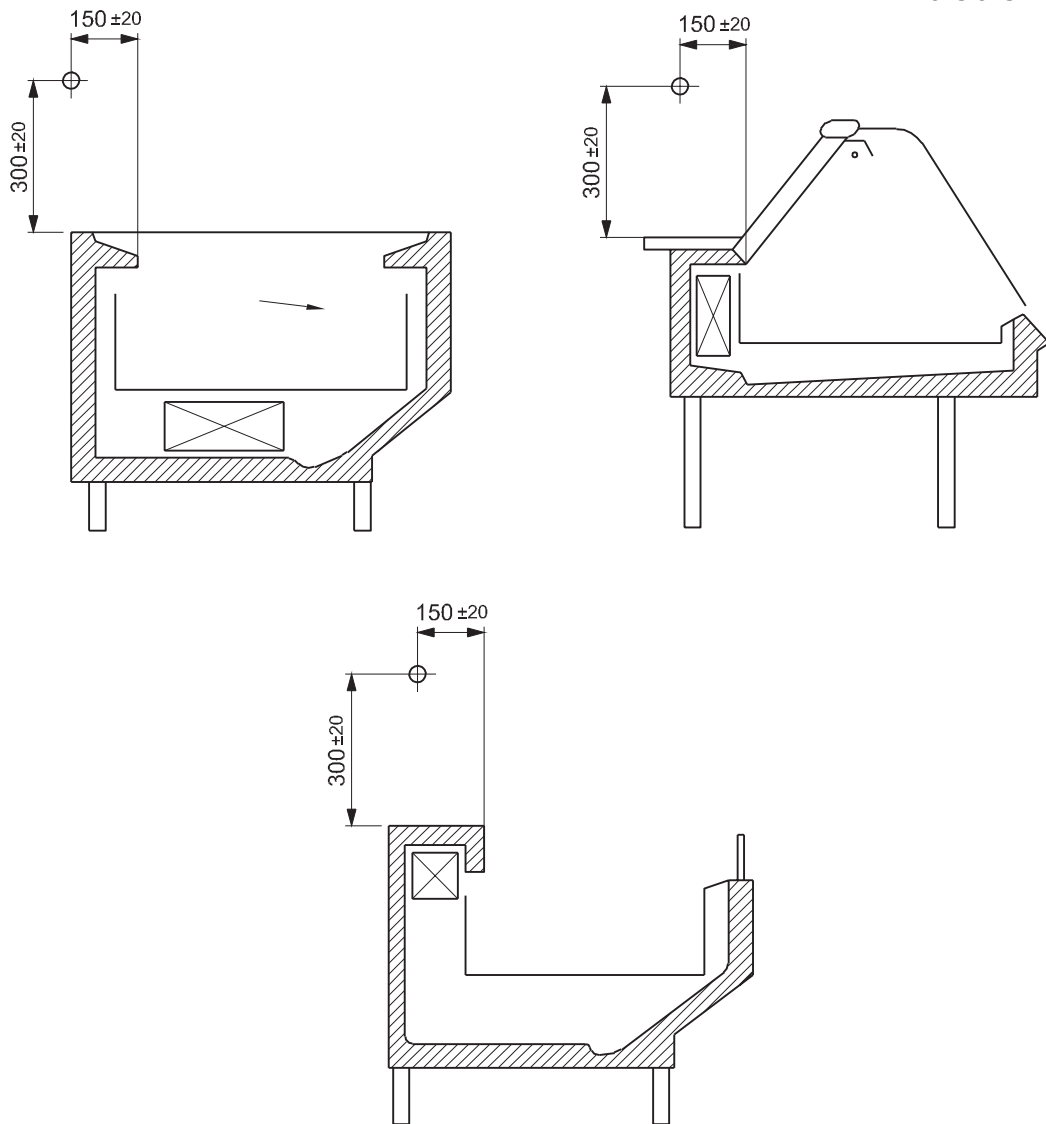

Figure 2 — Climate measuring point for two typical examples of horizontal open, wall site cabinets, and one example of serve-over counter cabinet

Dimensions in millimetres

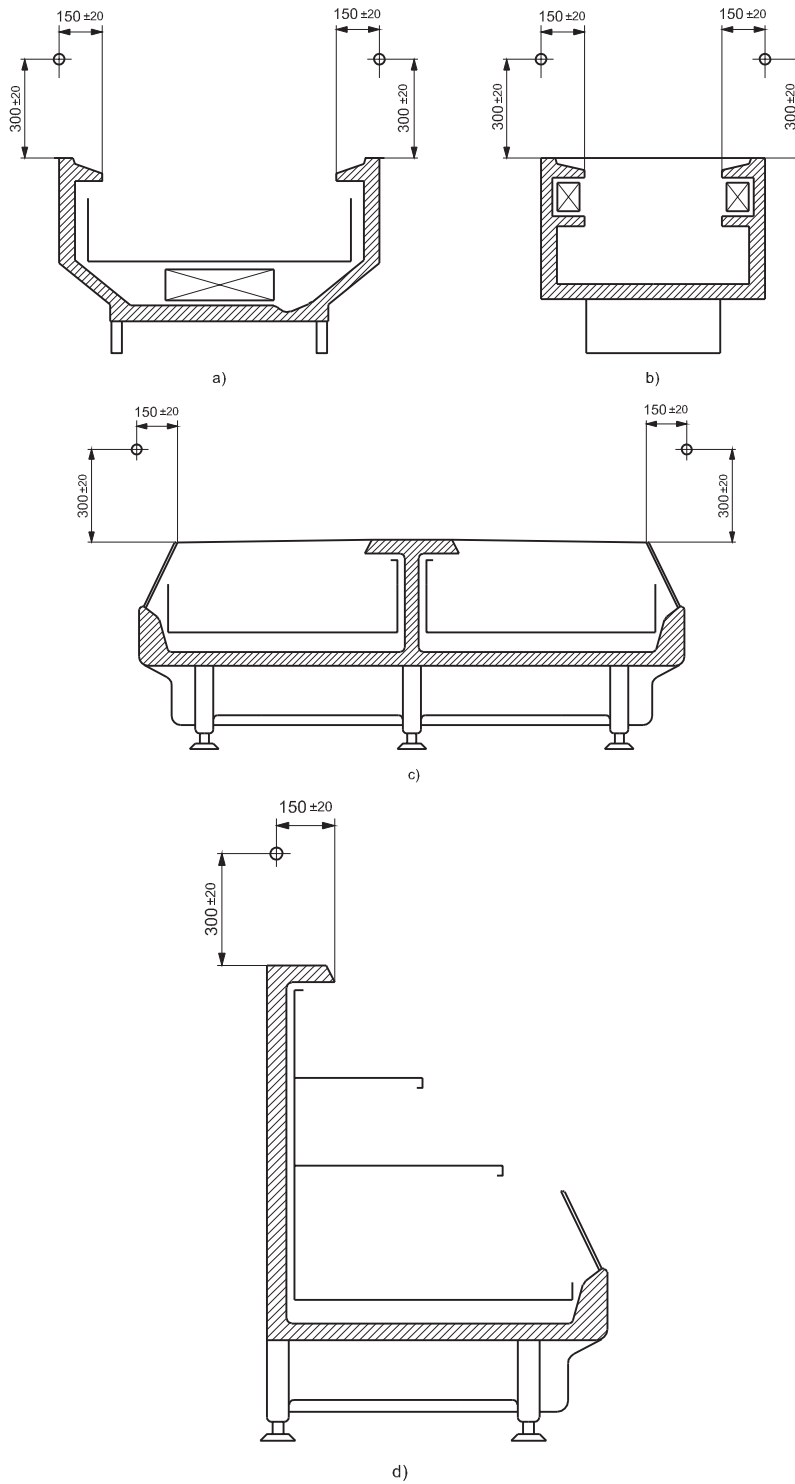

Figure 3 — Climate measuring point for two typical examples of horizontal, open, island site cabinets [a), b)] for island with air discharge in the middle [c)] and for semi-vertical cabinet [d)]

Dimensions in millimetres

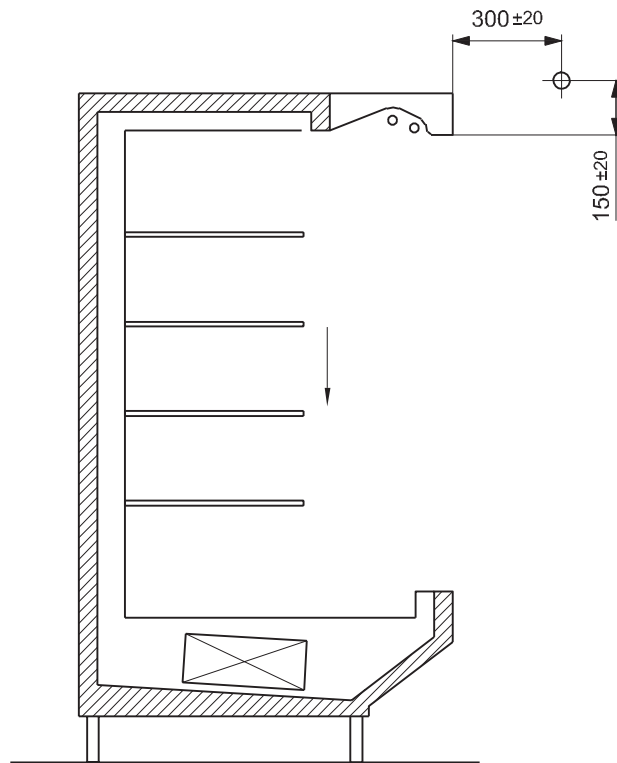

Figure 4 — Climate measuring points for one typical example of vertical multi-deck cabinet

Dimensions in millimetres

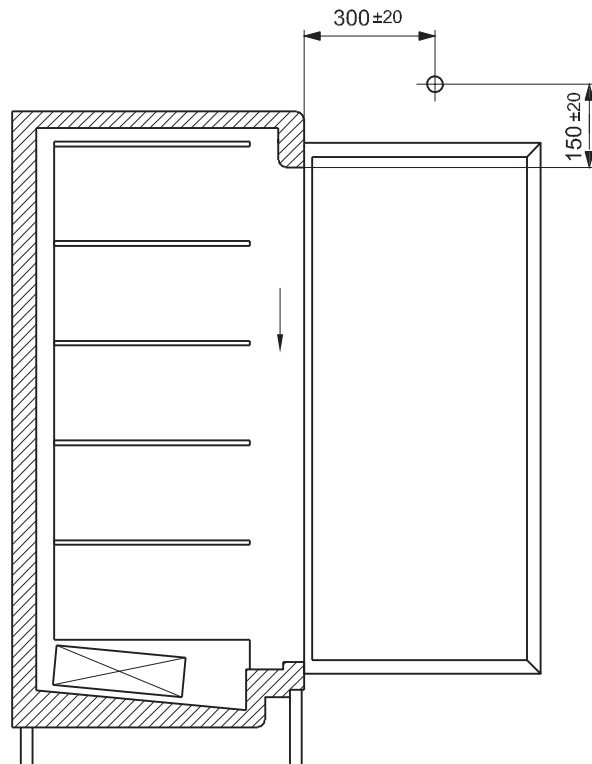

Figure 5 — Climate measuring point for one typical example of vertical glass door cabinet

5.3.1.4 Test packages and life-time

When tests are carried out, test packages in the form of right parallelepipeds shall be used; the size and mass of the test packages, including their packaging, shall be as specified in [Table 4](#).

The tolerances for new test packages shall be

- ±2 mm for linear dimensions 25 mm to 50 mm,
- ±4 mm for linear dimensions 100 mm to 200 mm, and
- ±2 % for mass.

Table 4 — Dimensions and mass of test packages

Dimensions mm	Mass g
50 × 100 × 100	500
50 × 100 × 200	1 000
The following packages may be used as fillers to complete the cabinet loading:	
25 × 100 × 200	500

Due to the frequency of use and to the loading pressure, the package could change in dimensions and weight. Test packages shall be checked at least annually for conformity with the following life-time tolerances. When a test package is found to exceed one of the tolerances, it shall be replaced.

- a) Loss of mass: -5 %
- b) On the wrapper: no visible hole
- c) Change in linear dimensions:
 - 1) ±4 mm for dimensions 25 mm and 50 mm;
 - 2) ±8 mm for dimensions 100 mm and 200 mm.

Each test package shall consist of filling material and a wrapper.

Filling material containing, per 1 000 g:

- 230,0 g of oxyethylmethylcellulose,
- 764,2 g of water,
- 5,0 g of sodium chloride, and
- 0,8 g of para-chlorometa-cresol.

The freezing point of this material is -1 °C (its thermal characteristics corresponding to those of lean beef). The enthalpy value of 285 kJ/kg shall correspond to the temperature (-1 ± 0,5) °C (see [Figure 6](#), [Tables 5](#) and [6](#)).

About 4 % of water should be added in order to compensate for evaporation during the preparation of the filling material.

Wrapper: a sheet of transparent colourless plastic or any other suitable material of such nature that exchange of moisture with the ambient medium is negligible being the surface emissivity coefficient equal to or greater than 0,9 at 25 °C. The maximum total thickness shall be 1,0 mm. After filling this sheet shall be sealed.

The correspondence of the packages' material composition with the above mentioned characteristics should be verified by the supplier or by an independent laboratory.

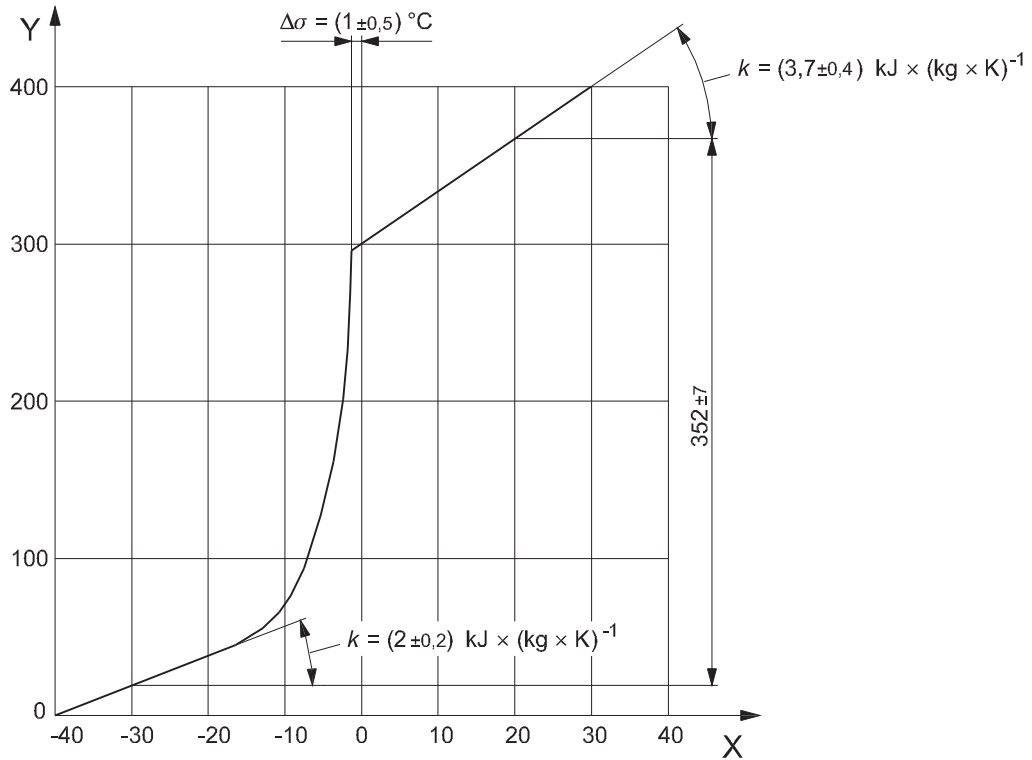

Key

X temperature, °C

Y specific enthalpy, kJ/kg

Figure 6 — Thermal characteristics of test packages

Table 5 — Temperature and specific enthalpy of test packages

Temperature °C	Specific enthalpy kJ/kg
-40	0
-30	19
-25	28
-20	39
-18	43
-16	49
-14	55
-12	63
-10	73
-9	79
-8	85
-7	93
-6	102
-5	114

Table 5 (continued)

Temperature °C	Specific enthalpy kJ/kg
-4	129
-3	152
-2	194
-1	285
0	297
+10	334
+20	371

Table 6 — Temperature and increase in specific enthalpy of test packages

Temperature range °C	Increase in specific enthalpy kJ/kg
-30 to -20	20 ± 2
+10 to +20	37 ± 4
-30 to +20	352 ± 7

5.3.1.5 M-packages and life-time

Some of the 500 g packages (50 mm × 100 mm × 100 mm) specified in 5.3.1.4 shall be equipped for temperature measurement, being fitted with temperature sensors inserted in the geometrical centre of the packages in direct contact with the filling material. All precautions shall be taken to minimize extraneous conduction of heat and to avoid any possibility of entrance of the air from the hole in the wrapper for the passage of the temperature sensor that could create oxidation and loss of weight in the filling material. These packages are called M-packages (see Figure 7).

Due to frequency of use and loading pressure the package could change in dimensions and weight. All M-packages shall be checked at least annually for conformity with the life time tolerances specified in 5.3.1.4. The checking results shall be recorded for each lot of M-packages. When an M-package is found to exceed one of the tolerances, it shall be replaced.

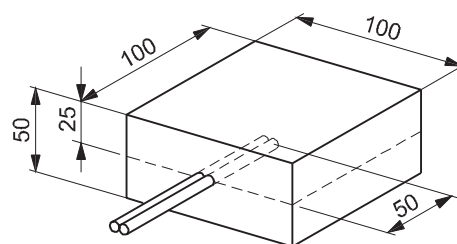

Dimensions in millimetres

Figure 7 — M-Package

5.3.1.6 Alternative for filling test packages

Alternative filling test packages having the dimensions shown in Table 4 and density of $(480 \pm 80) \text{ kg/m}^3$ can be used, except for rows and columns on transverse section containing M-packages.

This test package may be a box made of plastic material of any density, and of 1 mm nominal thickness. Cellular or foam material shall not be used. The case shall not incorporate any protrusions that would cause the vertical separation of packages in a stack. Opposite faces shall be substantially parallel,

and moulding draft shall be the minimum practicable. Seams or joints shall not result in protrusions sufficient to cause significant air gaps between adjacent packages.

Colour can be important if dark enough to be affected by ambient heat radiation; however, a pastel colour, e.g. light pink, pale blue or green, shall have no significant effect in normal surroundings.

The contents shall be water containing 0,08 % of para-chlorometa-cresol and 0,5 % of sodium chloride, soaked into a porous material such as a natural, plastics or cellulose sponge.

5.3.1.7 Instruments, measuring equipment and measuring accuracy

All measurements shall be carried out with instruments that have been calibrated.

- Temperature measurements shall be made to an accuracy of $\pm 0,8$ °C. Climate temperatures shall be measured by sensors, inserted in the centre of tinned solid copper or copper-zinc alloy cylinders having a mass of 25 g and of minimum external area (diameter = height = approximately 12,5 mm).

Specially for the test of a cabinet intended for connection to an indirect type refrigerating system, secondary refrigerant temperature difference measurements shall be made to an accuracy of $\pm 0,1$ °C (see [5.3.6.2.2](#)).

- Illumination flux per square metre shall be measured to an accuracy of ± 10 %.
- Pressures shall be measured to an accuracy of ± 1 %.
- Relative humidity shall be measured to an accuracy of ± 3 units of the percentage figure.
- Electrical energy consumption shall be measured to an accuracy of ± 2 % (see [5.3.5](#)).
- Time interval measurements shall be made to an accuracy of ± 1 % or better. All the temperatures are checked every 60 s.

The time interval for the measurements of refrigerant mass flow rate, inlet/outlet temperature and inlet and suction pressure shall be 20 s (see [5.3.6.2](#)).

- Air velocity shall be measured using a laboratory-type instrument with an accuracy of 10 % or $\pm 0,03$ m/s whichever is the greater and with a minimum sensitivity of 0,03 m/s in the range of 0 m/s to 1,5 m/s in horizontal flow at the temperature of the selected ambient class.
- Mass flow rate shall be measured to an accuracy of ± 1 % (see [5.3.6](#)).

5.3.2 Preparation of test cabinet and general test procedures

5.3.2.1 Cabinet selection, installation and positioning within the test room

Each refrigerated display cabinet intended to be tested, unless a prototype, shall be selected from stock or routine production and shall be representative as to construction and adjustment.

The cabinet, including all components required for normal operation, shall be assembled, set up and sited as it would be installed in service as far as practicable and in accordance with the manufacturer's instructions. All permanently located accessories required for normal use shall be in their respective places.

The cabinet shall be located as follows (see [Figure 8](#)).

$X \geq 1,5$ m and $B \geq 0,5$ m for vertical glass door cabinets of length less than 1,6 m and horizontal closed cabinets;

- $X = 2$ m and $B \geq 1$ m for all other cabinets;
- $Y \geq 1,5$ m for open vertical cabinets and combined cabinets with open top, defined as cabinet families VC1, VC2, VC3, VF1, VF2, YC1, YC2, YF1, YF2, YM5, YM6 (see ISO 23953-1:2015, Annex A);

- $Y \geq 0,8$ m for horizontal cabinets, vertical cabinets with glass doors and combined cabinets with glass door top, defined as cabinet families HC1, HC2, HC3, HC4, HC5, HC6, HF1, HF3, HF4, HF5, HF6, VC4, VF4, YC3, YC4, YF3, YF4, YM7, YM8 (see ISO 23953-2:2015, Annex A);
- $A \geq 0,8$ m
 $A = Y$ should be used when $A \geq 1,5$ m;
- $C \geq$ height of cabinet +0,5 m (for vertical cabinets).

The cabinet shall be located within the test room perpendicularly to the two technical side walls in such a way that the distances A (and respectively Y) measured at the two ends of the cabinet is equal with a tolerance of ± 4 mm for each meter of length of the cabinet.

For cabinets intended to be placed against a wall, and in order to check the running of cabinets with incorporated condensing unit correctly according to [5.3.2](#) or the water vapour condensation according to [5.3.4](#), a vertical partition shall be placed either against the rear of the cabinet or at a distance d_p from the rear as specified by the manufacturer [see [Figure 8](#) and [9](#)].

For all vertical and semi-vertical cabinets, with incorporated condensing unit, when the warm condenser air flow direction is across the testing room air flow direction, from the front to the back of the cabinet, then an air deflector positioned as shown in [Figure 9](#) shall be used in such a way to create a duct between the back of the cabinet and the vertical panel. This duct shall be closed in the front end side towards the testing room airflow discharge direction and open in the opposite side. On the top this duct shall be closed at the same height of the cabinet.

The distance, d_p , between the back of the cabinet and the vertical panel shall be specified by the manufacturer (see [Figure 9](#)).

Dimensions in millimetres

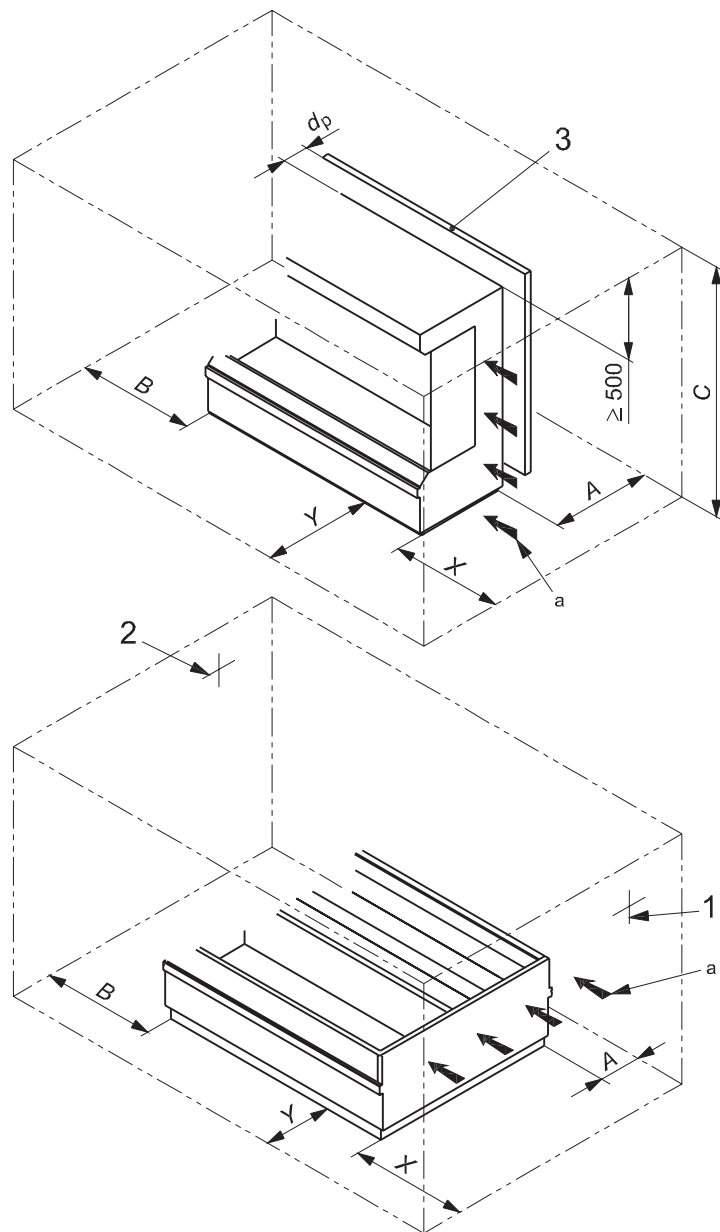

Key

- d_p partition distance specified by the manufacturer
- 1 technical side wall — test room air discharge
- 2 technical side wall — test room air return
- 3 vertical partition for wall site cabinet with same length and height as cabinet
- a air currents parallel to the plane of the opening (in longitudinal direction)

Figure 8 — Cabinet location within test room

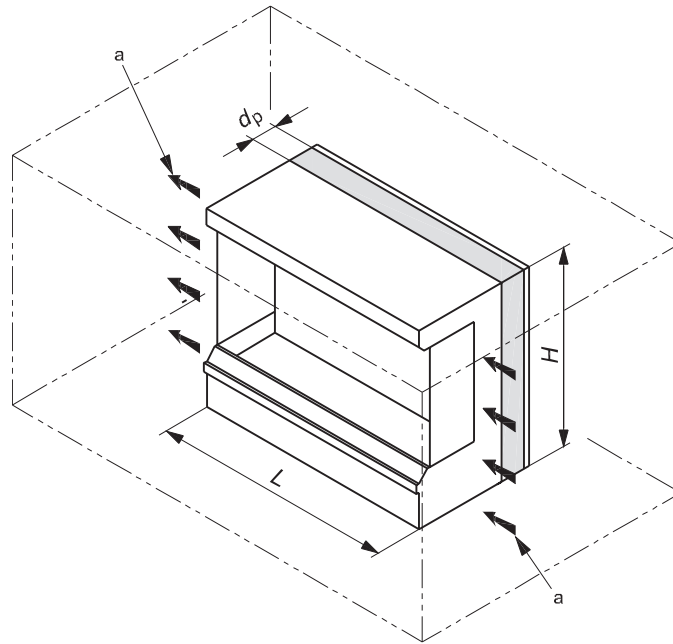

Key

L length of the air back duct = length of the cabinet

H height of the air back duct = height of the cabinet

d_p depth of the air back duct

a air currents parallel to the plane of the opening (in longitudinal direction)

Figure 9 — Size and position of the air back duct

For horizontal plug-in cabinets a back duct is not required.

NOTE In general the power of horizontal cabinets is much lower than that of vertical cases.

The warm condenser air can be removed by the test room airflow.

The air movement of the test room shall be parallel to the longitudinal axis according to [5.3.2.2](#).

The direction of the warm condenser airflow should be the same as the test room air flow direction and not opposed to it.

If this is not possible because of the cabinet's design the condenser airflow should be across the test room airflow direction (see [Figure 10](#)).

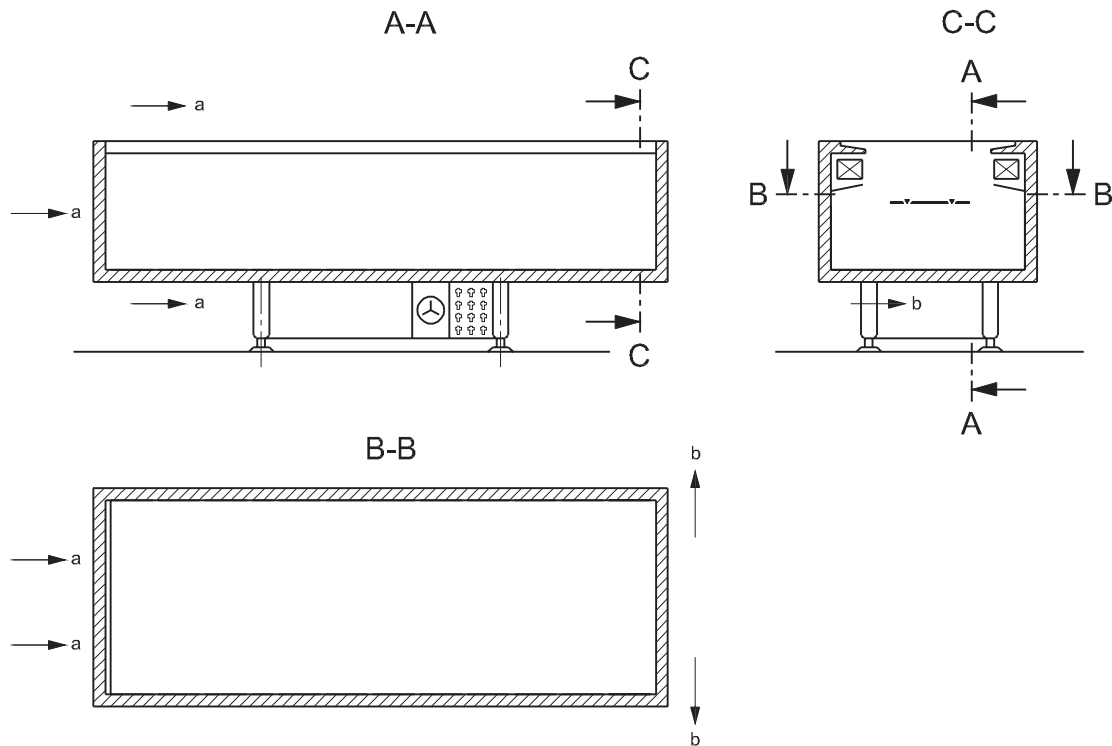
**Key**

- a air currents parallel to the plane of the opening (in longitudinal direction)
- b air flow direction of condensing unit

Figure 10 — Condensing air with test room air flow, or across, but not opposed the test room air flow

5.3.2.2 Air movement

Air movement shall be provided. The air movement, shall be, as far as practicable, parallel to the plane of the cabinet display opening and to the longitudinal axis. The length of the cabinet is defined as the longest horizontal dimension of the display opening. With the refrigerated display cabinet switched off, the air velocity at the three points along the line shown in [Figure 11](#) shall be $0,2 \begin{smallmatrix} +0 \\ -0,1 \end{smallmatrix}$ m/s.

For closed refrigerated cabinets with lids or doors hinged in a way that the rotation axis is perpendicular to the longitudinal axis of the cabinet the direction of air flow shall be such that the air movement is parallel to the plane of the cabinet display opening and the air enters the cabinet when the door(s) or lid(s) is (are) open.

The majority of the doors or lids shall open in order to allow the air entry into the cabinet; if doors or lids can be indifferently hinged left and right, all doors or lids shall open in the same direction.

Test room air movement shall be checked during the test in order to be sure that the test room is running correctly. The method of checking is left to the discretion of testing authority.

Dimensions in millimetres

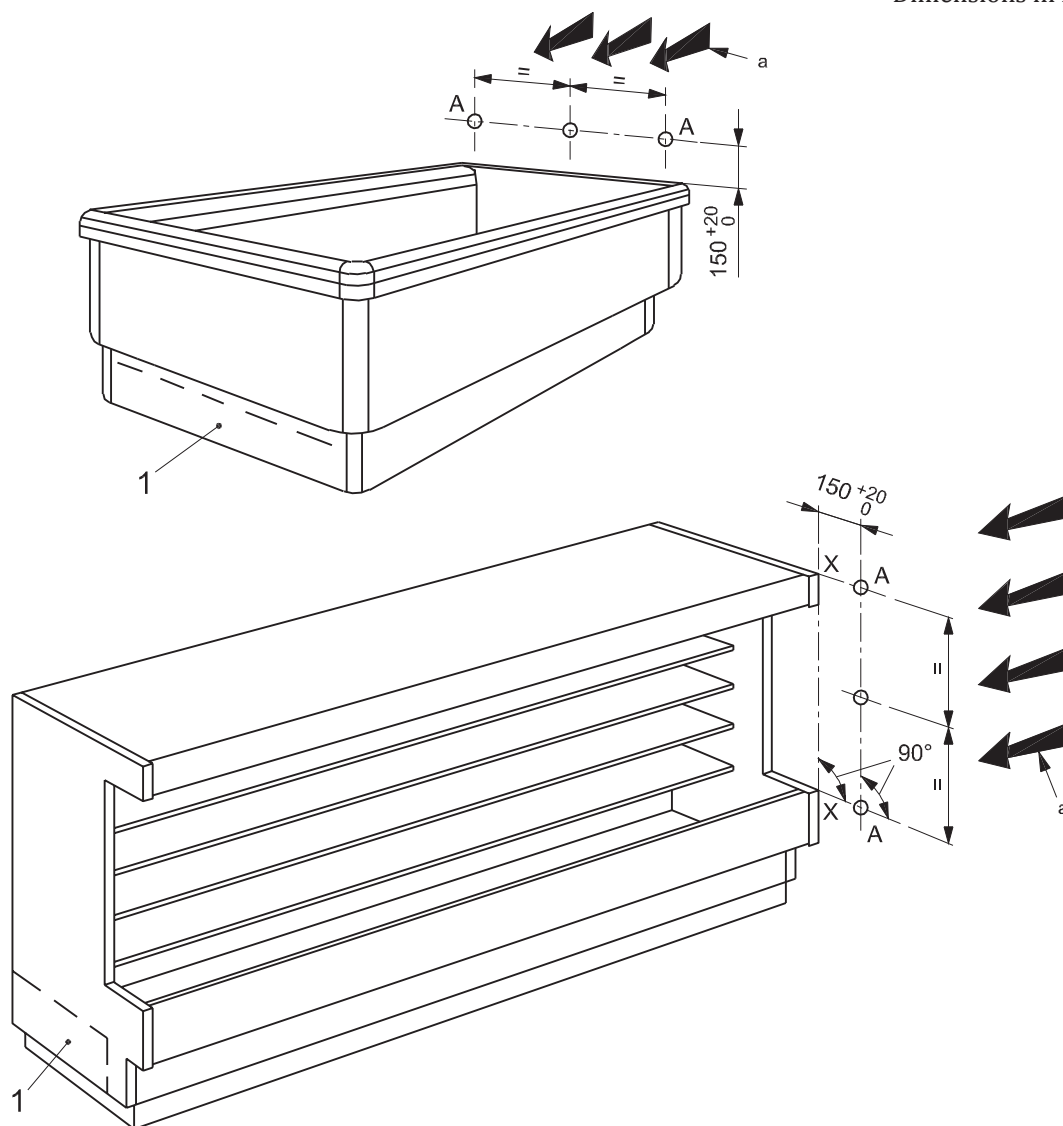

Key

- A-A line for the measurement of the air velocity
- X-X reference line joining the end of the upper part and the end of the lower part of the cabinet
- 1 possible location of condensing unit
- a air currents parallel to the plane of the opening (in longitudinal direction)

Figure 11 — Air movement

5.3.2.3 Loading the cabinet

5.3.2.3.1 General

The cabinet shall be loaded with test packages and M-packages (see 5.3.1.4 and 5.3.1.5) up to the load limit, as illustrated in Figures 12 to 27. These packages shall have been brought previously to a temperature equal to that expected during the test.

1 000 g packages and 500 g packages should be used.

To complete the loading, use test packages of the following sizes as fillers:

- 25 mm × 100 mm × 200 mm.

The test packages shall be arranged so as to form an even level.

Each refrigerated shelf area shall be loaded with test packages arranged in such a way that they form rows with a width of 200 mm by the depth of the cabinet in the direction of the airflow in the cabinet.

A clearance of 25 mm ± 5 mm shall be left between package rows and adjacent to the internal end walls of the cabinet.

It is permitted to use partitions with a thickness of approximately 25 mm to position the packages on condition that they have minimal effect on normal airflow and minimal thermal conduction.

Lengthways, any remaining spaces shall be filled with test packages to obtain one or two adjustment rows of which the width can measure from 100 mm up to 300 mm.

Depth-wise, any remaining spaces of less than 25 mm wide shall be filled with wooden vertical dividers, placed approximately midway along the space between two M-packages.

For roll-in cabinets or multi-deck cabinets with a loading height above 500 mm (see [Figure 26](#)), some wood loading may be used. The thickness of each layer is not specified.

EXAMPLE Varnished pieces of exterior grade beech plywood with good water resistance, 200 mm by 50 mm by the depth of loading.

Metallic grids can be used to support the test package loading on M-package rows and the adjacent ones.

For roll-in cabinets, if not otherwise stated in the manufacturer's manual or marked inside the cabinet, the packages and the wood shall be loaded on standard Euro pallets (1 200 × 800 × 144) mm or if not applicable on a similar tray of the same height. The surface of the pallet should be covered by a sheet of plastic or carton so that the packages can be loaded properly.

If the cabinet is designed for the use of special storage trolleys, these trolleys shall be used for testing. In this case the M-packages shall be positioned as specified in the above [Figure 26](#) but inside the trolleys.

NOTE Sensitive foodstuff loading type might be possible only for top part (shelves) of this kind of cabinets.

5.3.2.3.2 Loading heights

The loading height of the refrigerated shelves shall be as follows:

- a) For horizontal cabinets, the loading height shall be equal to the height defined by the load limit, with a tolerance of $\begin{matrix} 0 \\ -25 \end{matrix}$ mm (see [Figure 12](#) and [Figures 14](#) to [19](#)).
- b) For chilled vertical cabinets with a minimum of two superimposed refrigerated shelves, the loading height shall be equal the free height between the refrigerated shelves minus 25 mm, with a tolerance of $\begin{matrix} 0 \\ -25 \end{matrix}$ mm (see [Figures 20](#) to [24](#) and [Figure 26](#)).
- c) For all cabinets, intended for sensitive foodstuffs not suitable for multiple layer stacking, the loading shall be equal to 100 mm (for an example, see [Figures 13](#) and [25](#)).
- d) For closed frozen vertical cabinets, the loading height shall be equal to half of the maximum free height above the refrigerated shelf, with a tolerance of $\begin{matrix} +25 \\ 0 \end{matrix}$ mm (see [Figure 27](#)).

NOTE The meaning of "intended for sensitive foodstuffs not suitable for multiple layer stacking" is that the foodstuffs are displayed on tilted shelves, where it is not possible to make a load level over 100 mm. This type of loading can also be used for horizontal shelves. It is intended that manufacturers indicate the load limit in the technical documentation and also specify the type of loading used for testing the cabinet.

5.3.2.3.3 M-package locations

The M-packages shall be placed at the position shown on the cabinet drawings (see [Figures 12 to 27](#)).

5.3.2.3.3.1 Longitudinal section

For cabinet lengths of less than or equal to 700 mm, M-packages shall be located into two transverse sections of the loading such that the M-package axis is situated at 75 mm from each cabinet end wall.

For cabinet lengths of more than 700 mm, a third transverse section shall be placed midway along the cabinet length, with a tolerance of 75 mm. When the cabinet includes at its central area any mechanical structure, M-packages of this third transverse section and located against the back panel shall be shifted towards the test room air discharge side by 325 mm.

5.3.2.3.3.2 Cross-section

For all shelf depths, M-packages shall be located into two longitudinal sections, such that the M-package axis is situated at 50 mm from the back panel and 50 mm from the front limit of loading (see [Figures 20 to 27](#)).

For all refrigerated base decks, M-packages shall be located into two longitudinal sections, such that the M-package axis is situated at 50 mm from the back panel and 50 mm from the front limit of loading (see [Figures 12 to 27](#)).

Additionally, for refrigerated base deck depths of more than 550 mm, a third longitudinal section shall be placed midway across the base deck depth with a tolerance of

- $d/2 +_0^{100}$ mm from the air-discharge side for cabinets with forced-air cooling [see [Figures 12 to 14](#), [Figure 16](#) (a) and (b) and [Figures 20 to 27](#)], or
- $d/2 \pm 50$ mm for natural-convection-cooled cabinets equipped with two evaporators or having a symmetrical layout (see [Figures 17 to 19](#)), or
- $d/2 +_0^{100}$ mm from the evaporator side for other natural-convection-cooled cabinets (see [Figure 15](#)).

In the height, for the base deck and each refrigerated shelf, M-packages shall be located into the lower and upper loading layers. When the distance between the axes of M-packages is more than 400 mm, another M-package layer shall be introduced (see [Figure 26](#)).

For cabinets with superimposed refrigerated shelves, M-packages shall be located in the following places (see [Figures 20 to 27](#)):

- on the chest;
- on the shelf above the chest;
- on the top shelf;
- plus every alternate shelf starting from the top shelf.

Dimensions in millimetres

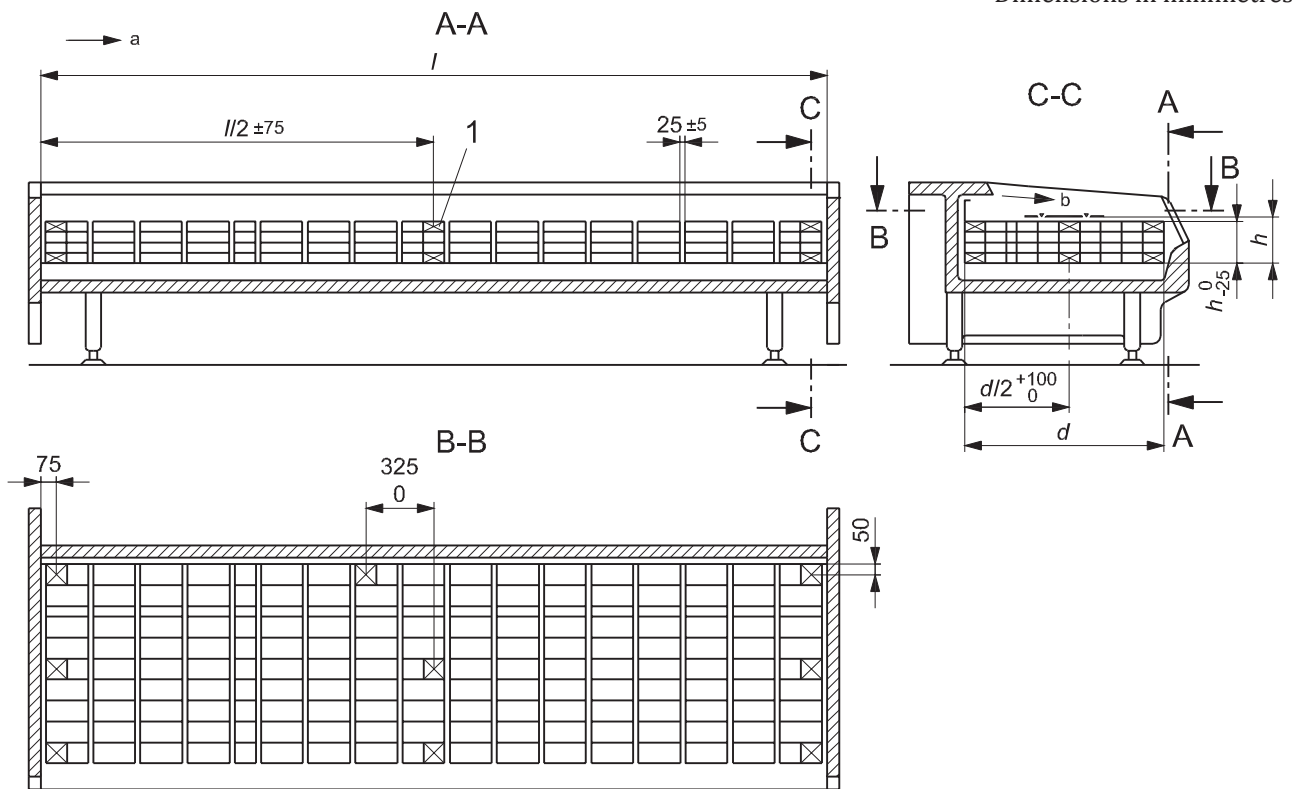

Key

- 1 M-package
- d depth of base deck
- h height at load limit
- l length of the cabinet
- a air currents parallel to the plane of the opening (in longitudinal direction)
- b direction of forced air flow

Figure 12 — Self-service counter provided with forced air cooling (horizontal open and closed)

Dimensions in millimetres

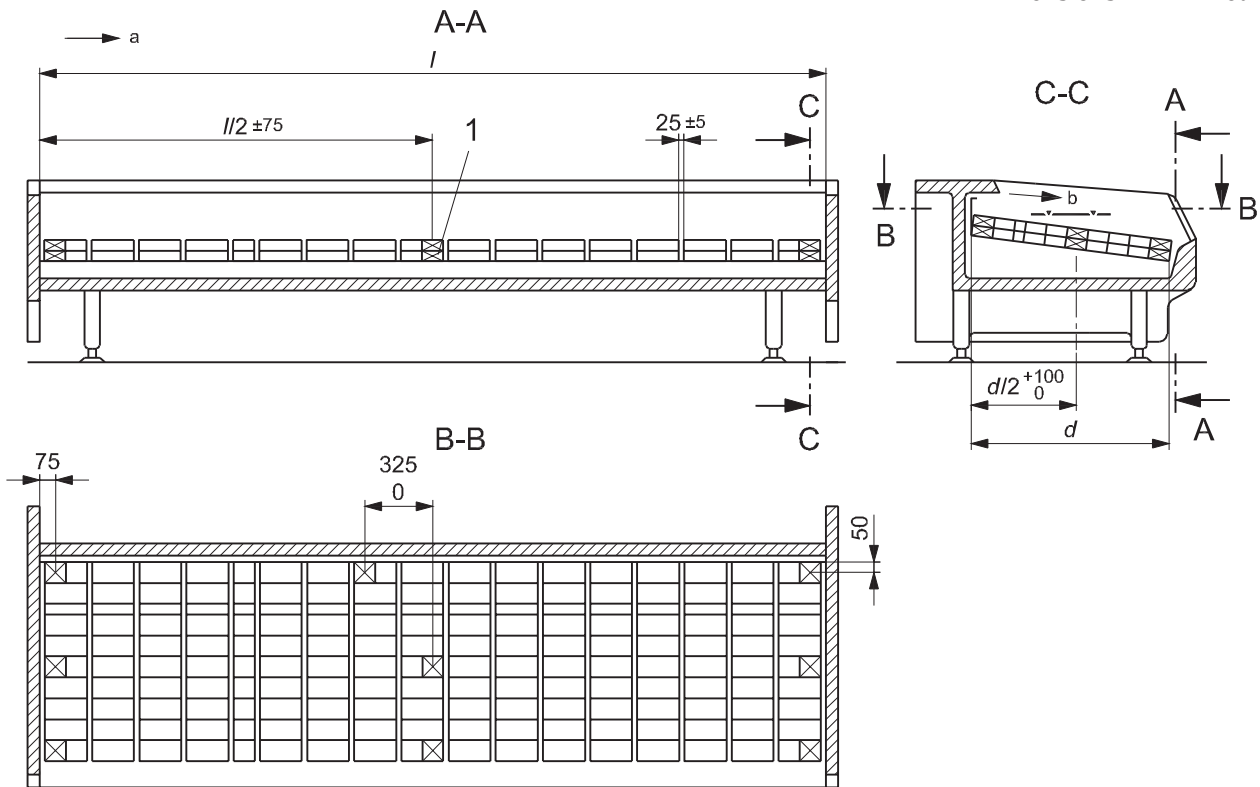

Key

- 1 M-package
- d depth of base deck
- l length of the cabinet
- a air currents parallel to the plane of the opening (in longitudinal direction)
- b direction of forced air flow

Figure 13 — Self-service counter provided with forced air cooling for sensitive foodstuffs (horizontal, open and closed)

Dimensions in millimetres

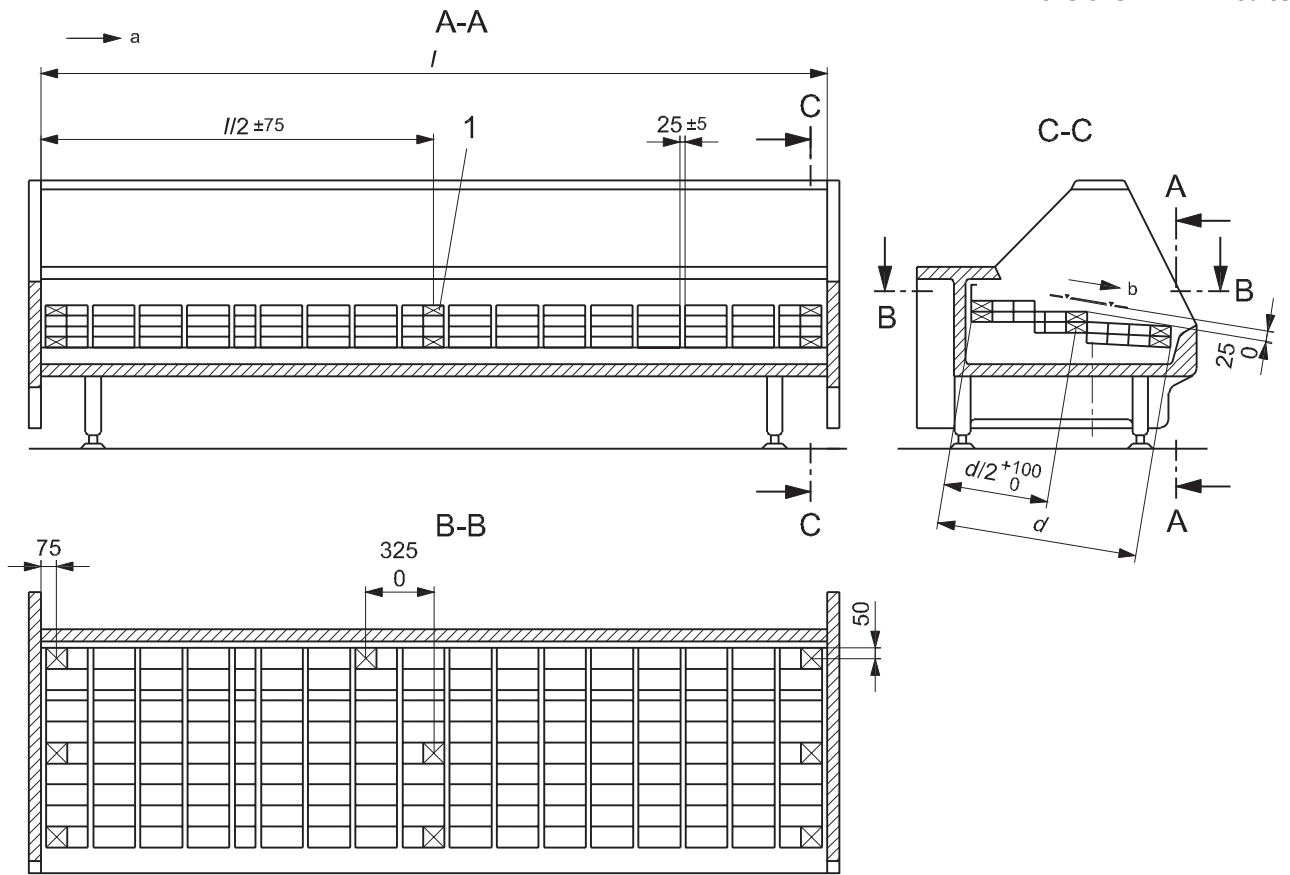

Key

- 1 M-package
- d depth of base deck
- l length of the cabinet
- a air currents parallel to the plane of the opening (in longitudinal direction)
- b direction of forced air flow

Figure 14 — Serve-over counter provided with forced air cooling (horizontal open and closed)

Dimensions in millimetres

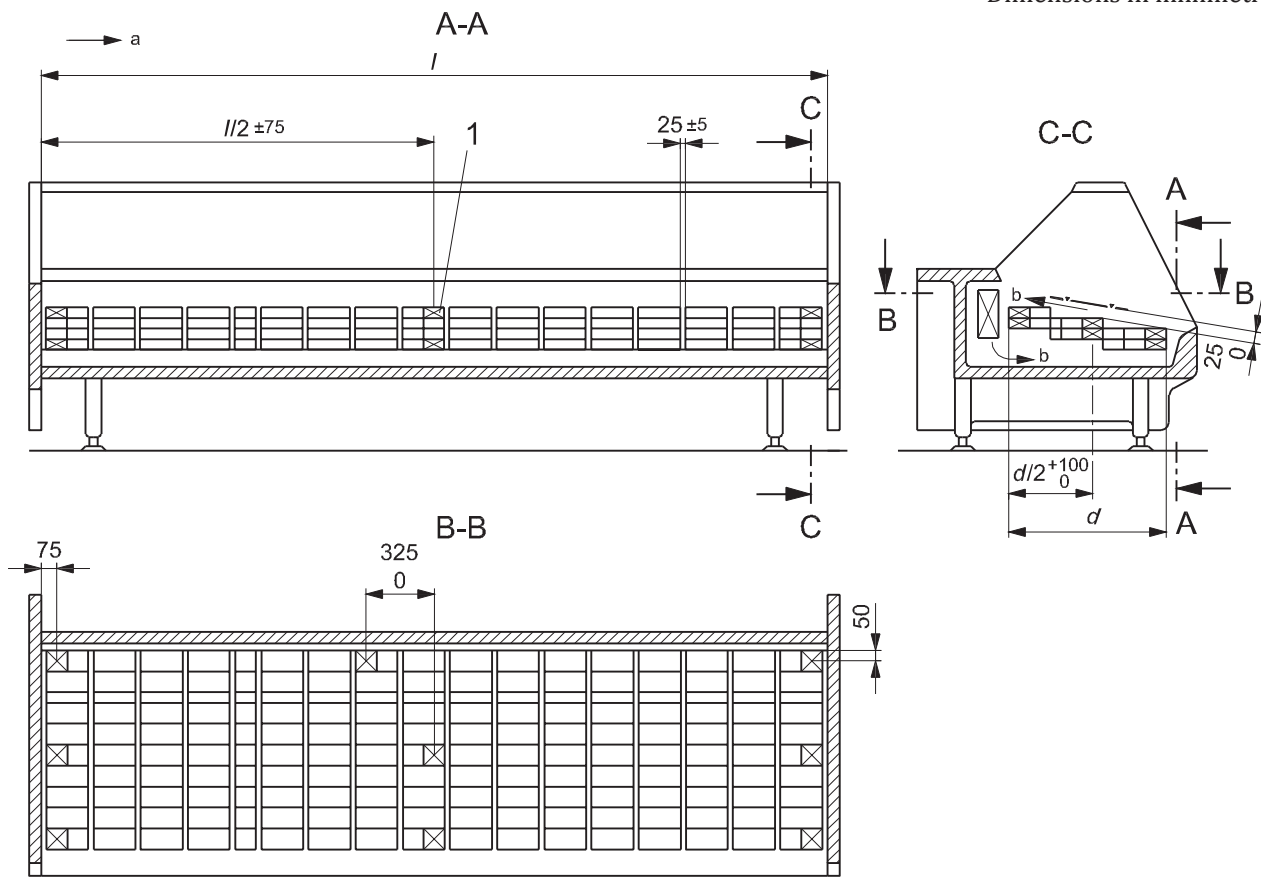

Key

- 1 M-package
- d depth of base deck
- l length of the cabinet
- a air currents parallel to the plane of the opening (in longitudinal direction)
- b direction of air flow

Figure 15 — Serve-over counter provided with natural convection cooling (horizontal open and closed)

Dimensions in millimetres

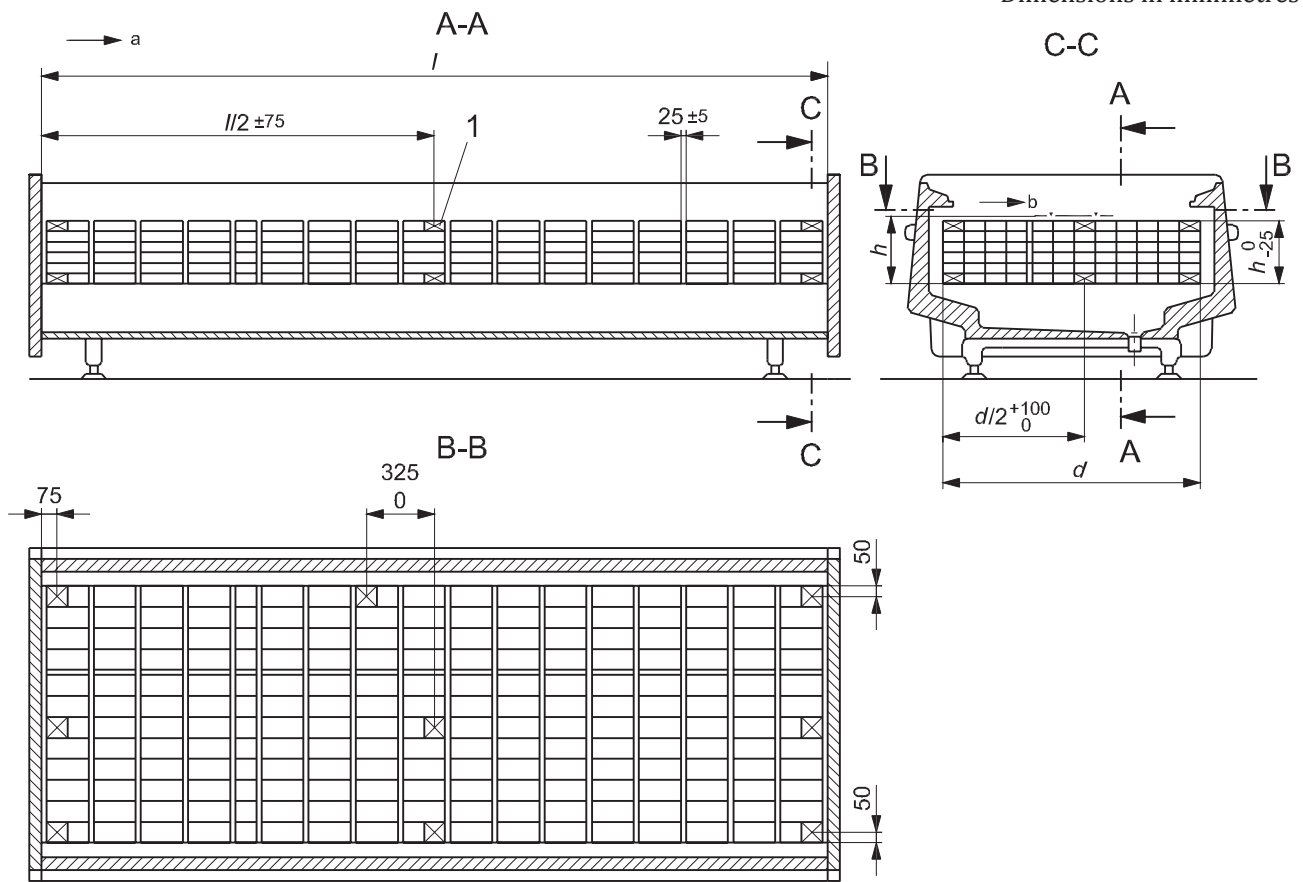

a) Island cabinet provided with forced air cooling (horizontal open and closed)

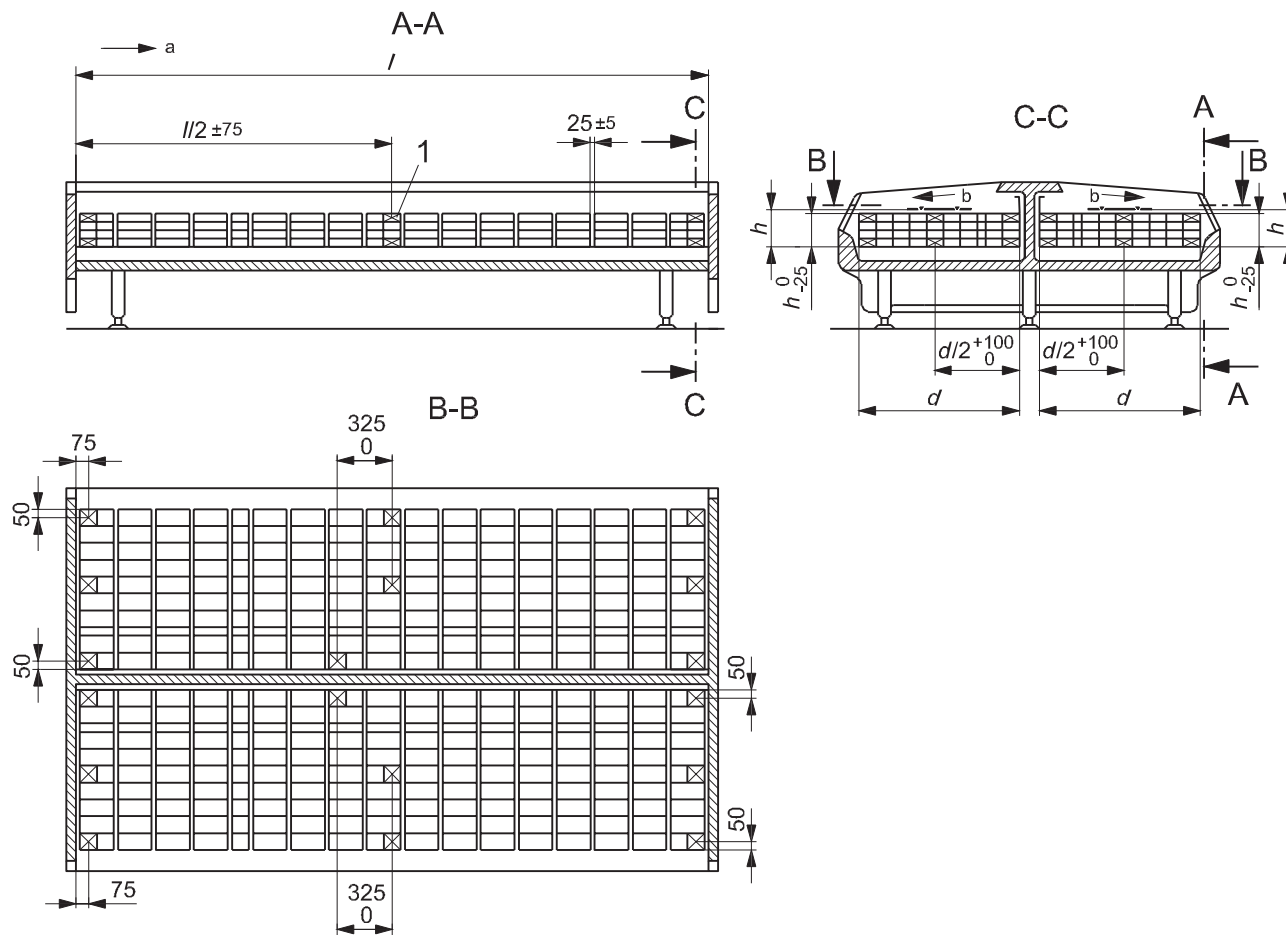

b) Island cabinet with air discharge in the middle

Key

- 1 M-package
- d depth of base deck
- h height at load limit
- l length of the cabinet
- a air currents parallel to the plane of the opening (in longitudinal direction)
- b direction of forced air flow

Figure 16 — Island cabinet provided with forced air cooling (horizontal open and closed) and island with air discharge in the middle

Dimensions in millimetres

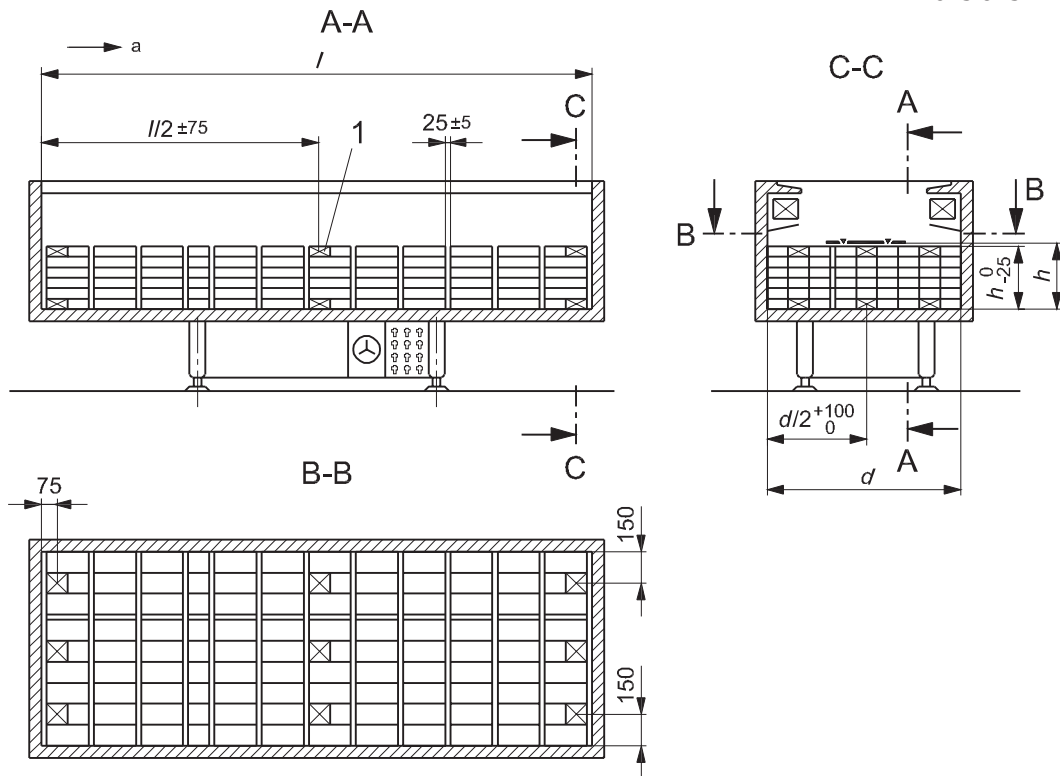

Key

- 1 M-package
- d depth of base deck
- h height at load limit
- l length of the cabinet
- a air currents parallel to the plane of the opening (in longitudinal direction)

Figure 17 — Island cabinet provided with natural convection cooling (horizontal, open and closed)

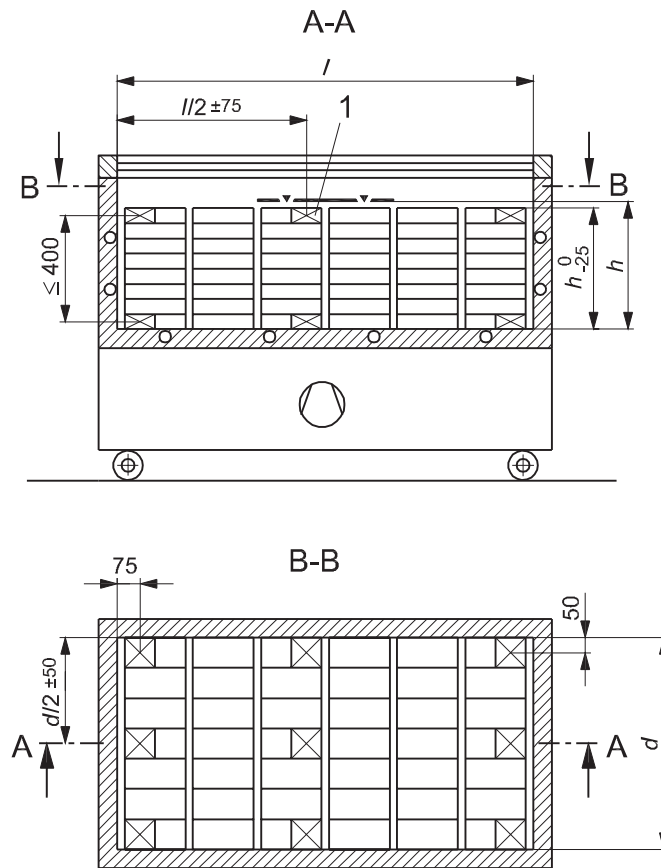

Key

- 1 M-package
- d depth of base deck
- h height at load limit
- l length of the cabinet

Figure 18 — Glass lid, island cabinet with flat base deck with and without tubes laid at the base (horizontal, closed)

Dimensions in millimetres

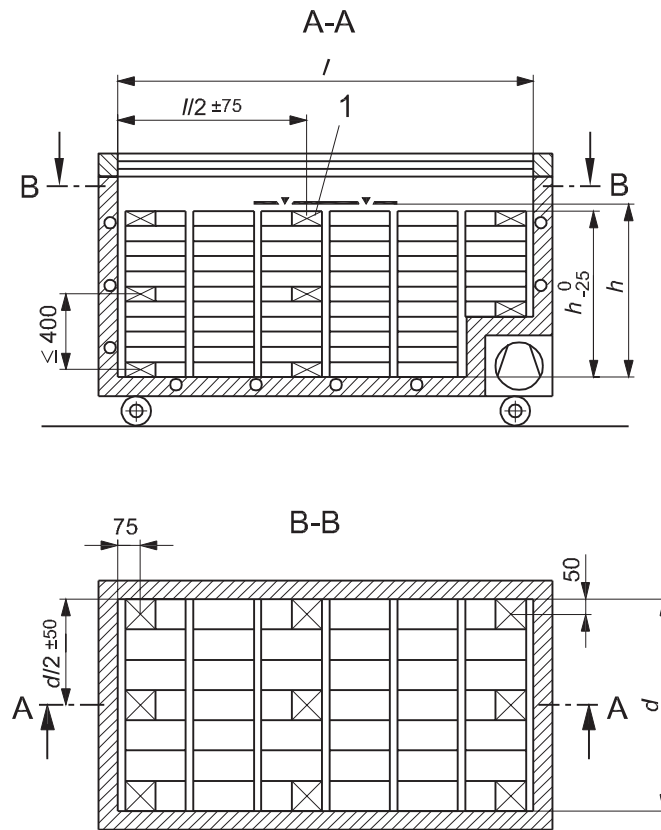

Key

- 1 M-package
- d depth of base deck
- h height at load limit
- l length of the cabinet

Figure 19 — Glass lid, island cabinet with stepped base deck with and without tubes laid at the base (horizontal, closed)

Dimensions in millimetres

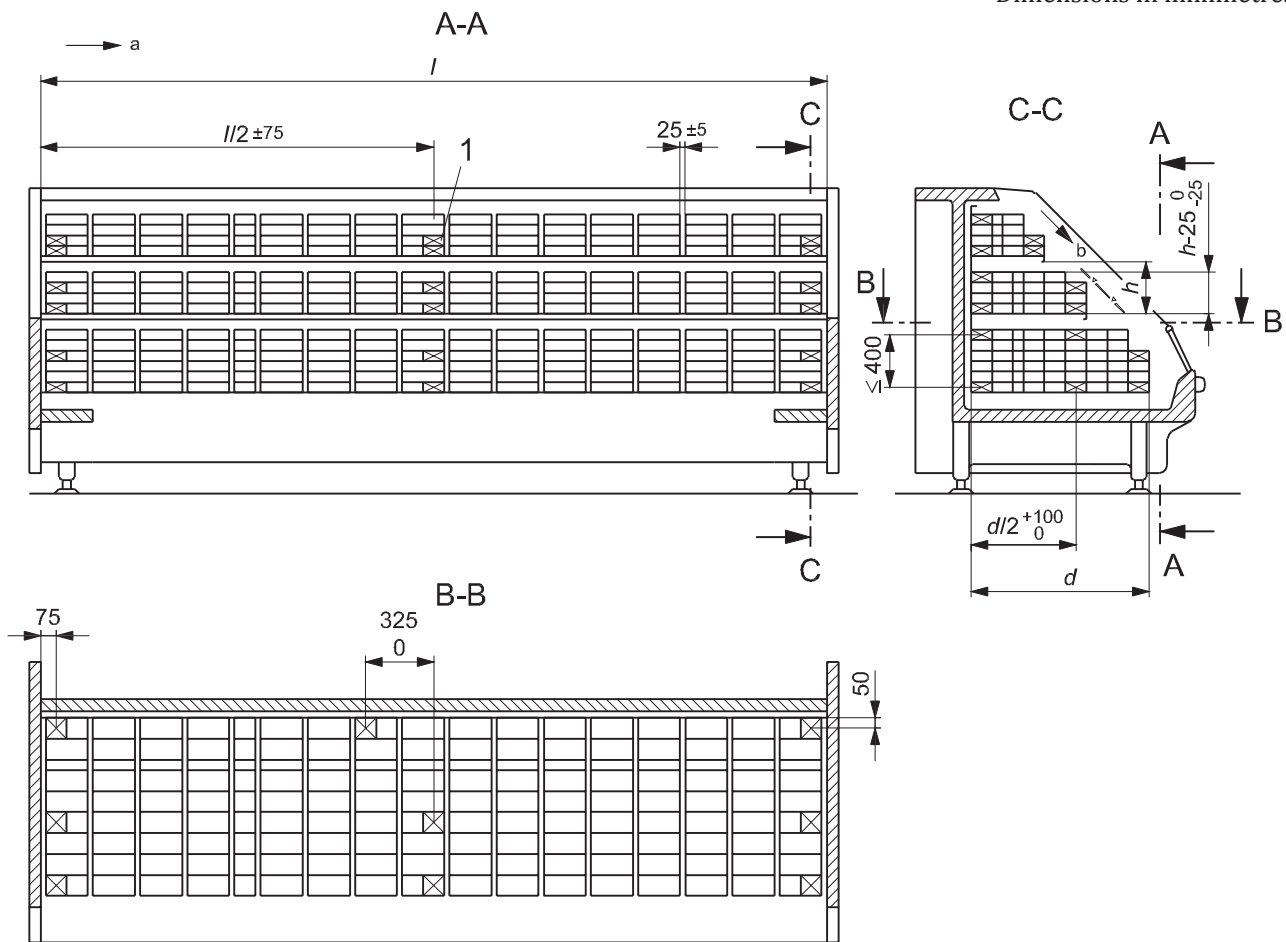

Key

- 1 M-package
- d depth of base deck
- h height at load limit
- l length of the cabinet
- a air currents parallel to the plane of the opening (in longitudinal direction)
- b direction of forced air flow

Figure 20 — Semi-vertical chilled cabinet (2 shelves) provided with forced air cooling (open and closed)

Dimensions in millimetres

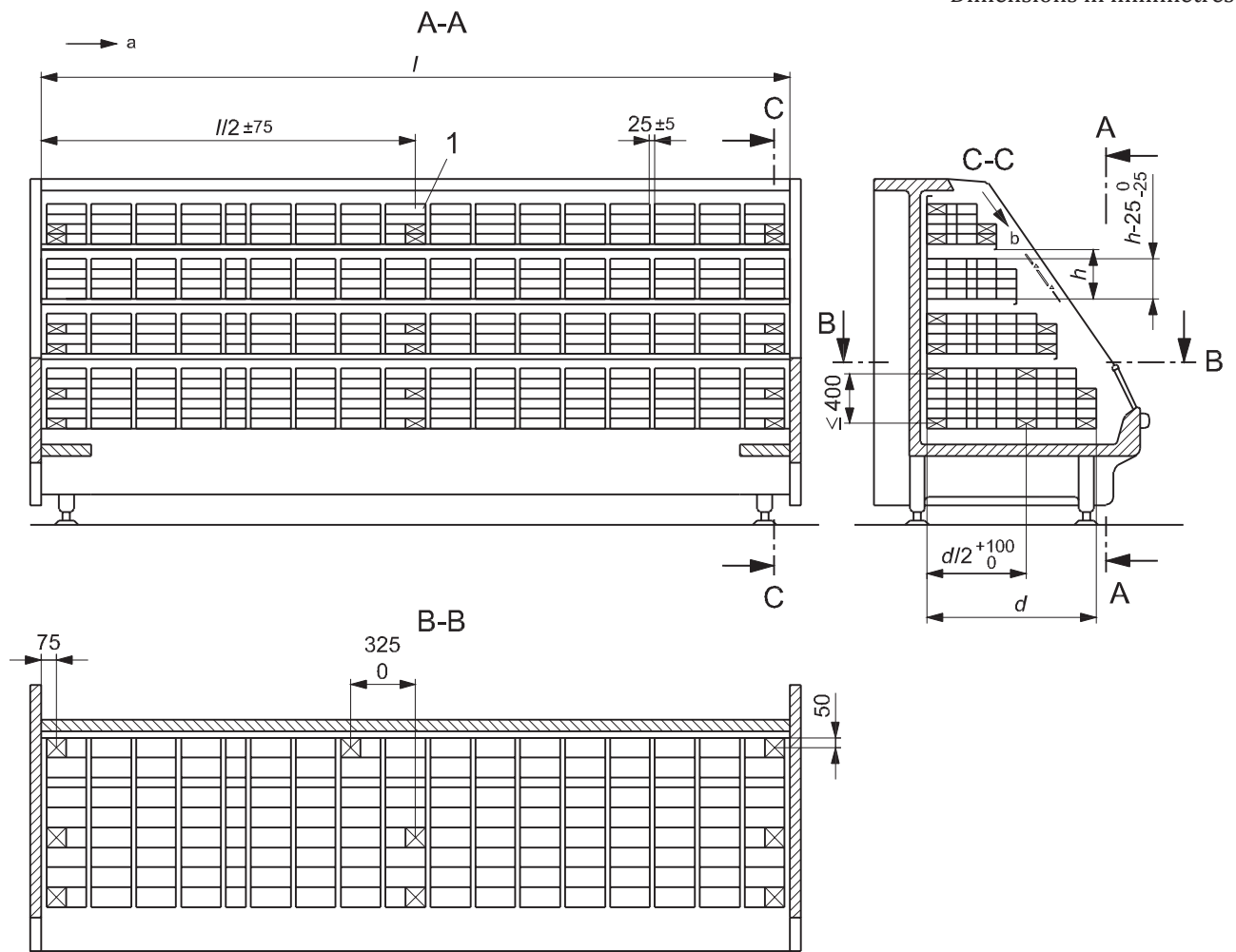

Key

- 1 M-package
- d depth of base deck
- h height at load limit
- l length of the cabinet
- a air currents parallel to the plane of the opening (in longitudinal direction)
- b direction of forced air flow

Figure 21 — Semi-vertical chilled cabinet (3 shelves) provided with forced air cooling (open and closed)

Dimensions in millimetres

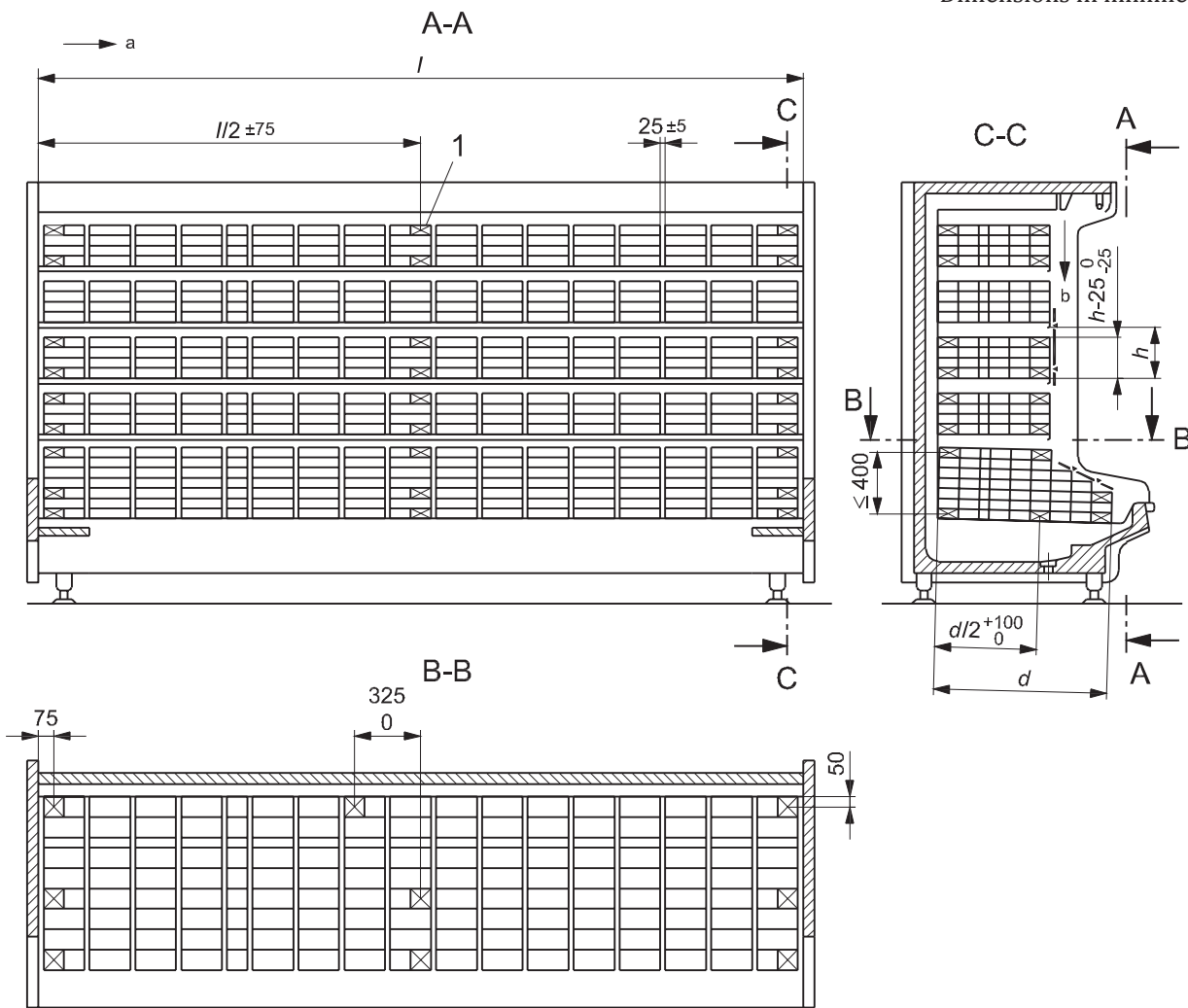

Key

- 1 M-package
- d depth of base deck
- h height at load limit
- l length of the cabinet
- a air currents parallel to the plane of the opening (in longitudinal direction)
- b direction of forced air flow

Figure 22 — Multi-deck chilled cabinet (4 shelves) provided with forced air cooling (vertical, open and closed)

Dimensions in millimetres

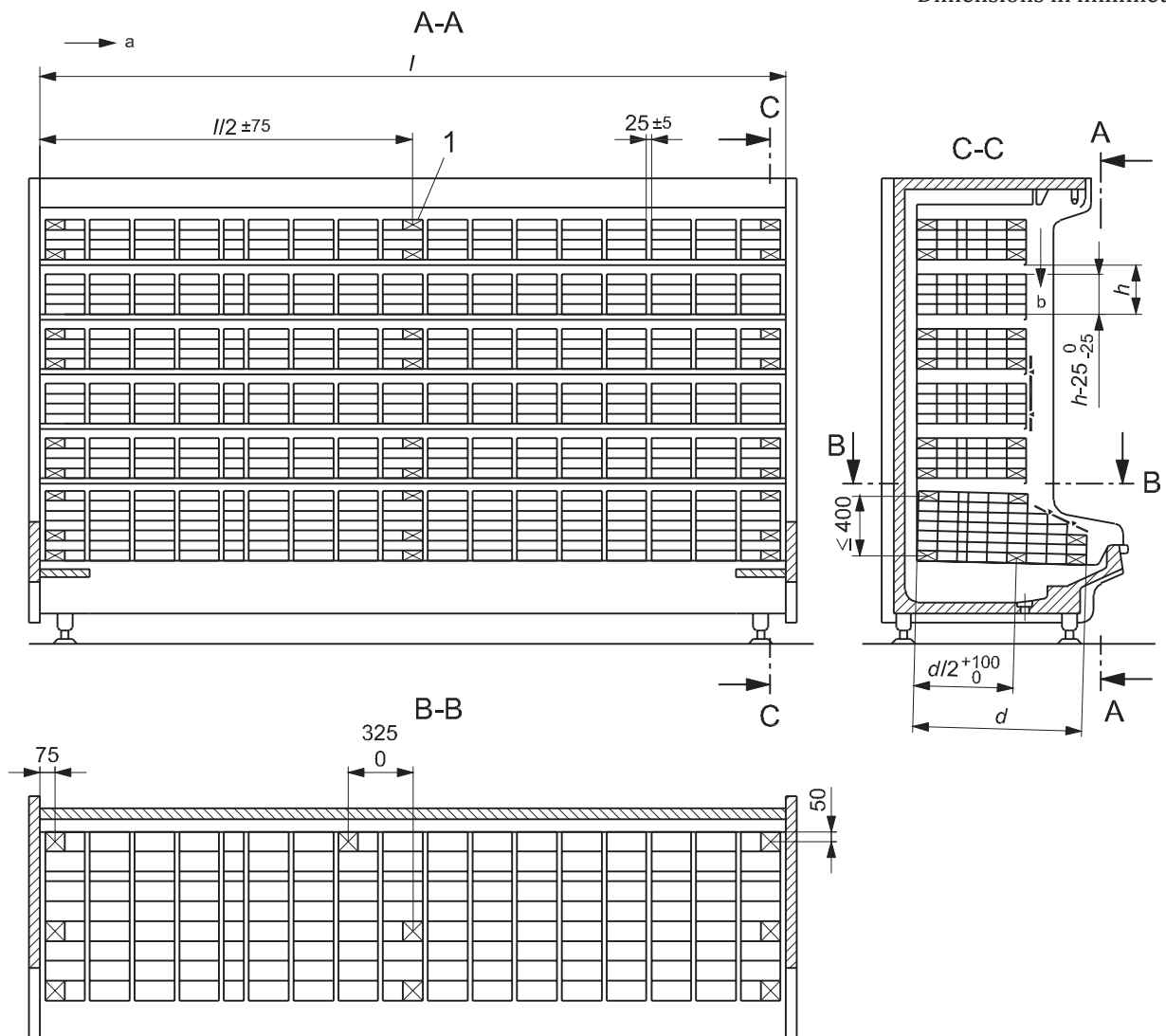

Key

- 1 M-package
- d depth of base deck
- h height at load limit
- l length of the cabinet
- a air currents parallel to the plane of the opening (in longitudinal direction)
- b direction of forced air flow

Figure 23 — Multi-deck chilled cabinet (5 shelves) provided with forced air cooling (vertical, open and closed)

Dimensions in millimetres

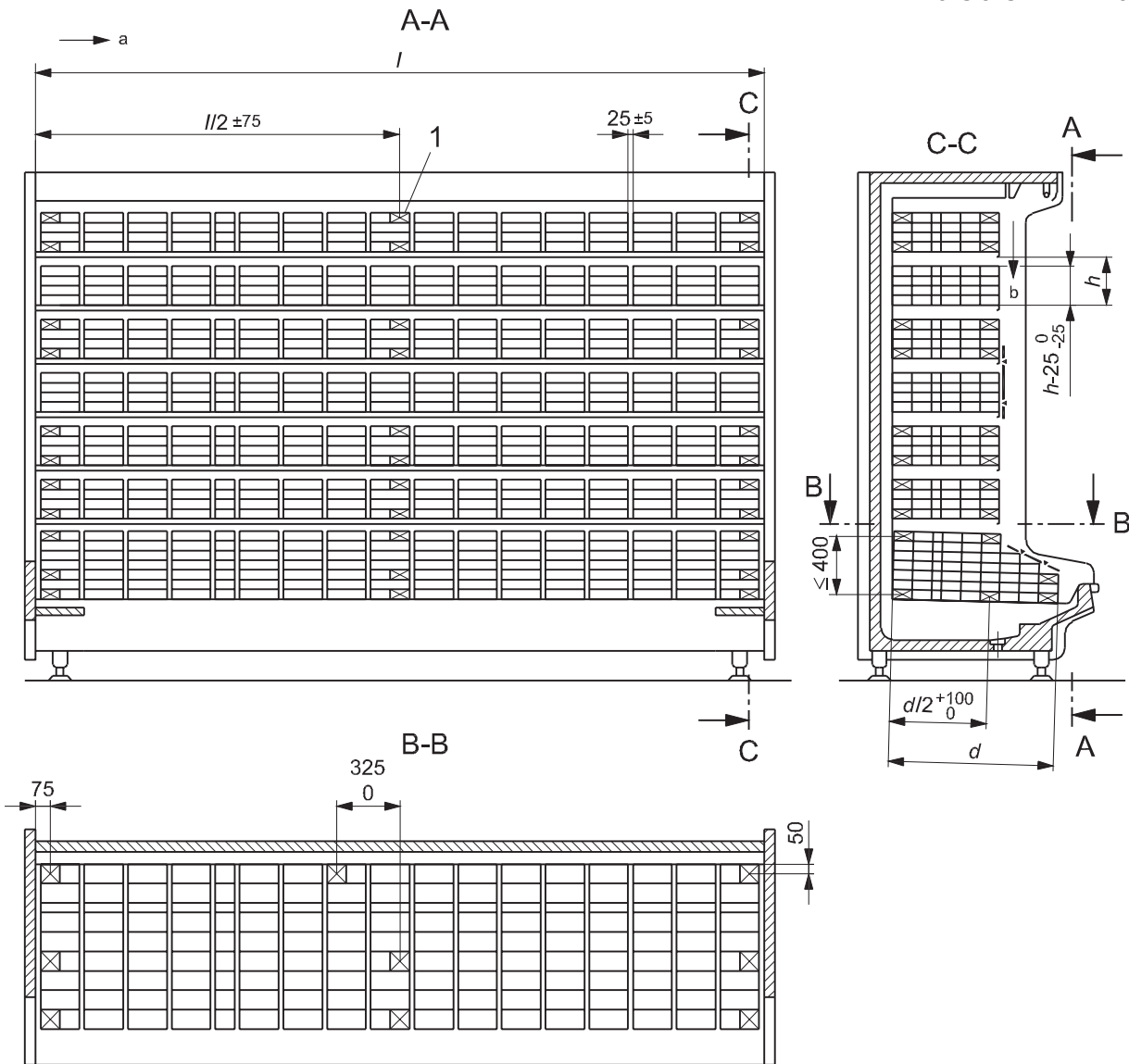

Key

- 1 M-package
- d depth of base deck
- h height at load limit
- l length of the cabinet
- a air currents parallel to the plane of the opening (in longitudinal direction)
- b direction of forced air flow

Figure 24 — Multi-deck chilled cabinet (6 shelves) provided with forced air cooling (vertical, open and closed)

Dimensions in millimetres

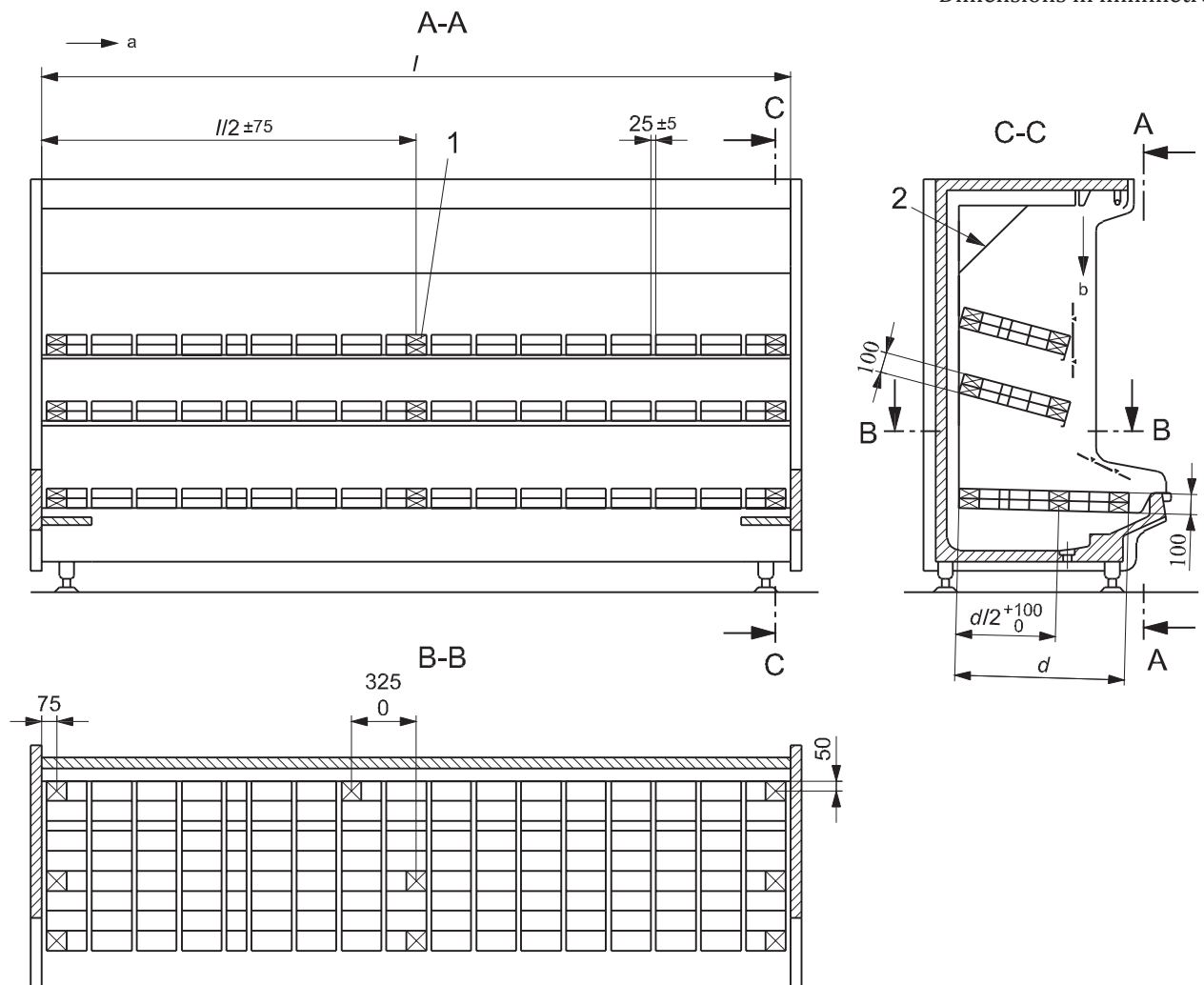

Key

- 1 M-package
- 2 mirror
- l* length of cabinet
- d* depth of base deck
- a* air currents parallel to the plane of the opening (in longitudinal direction)
- b* direction of forced air flow

Figure 25 — Multi-deck chilled cabinet (2 shelves) provided with forced-air cooling for sensitive foodstuffs (vertical, open and closed)

Dimensions in millimetres

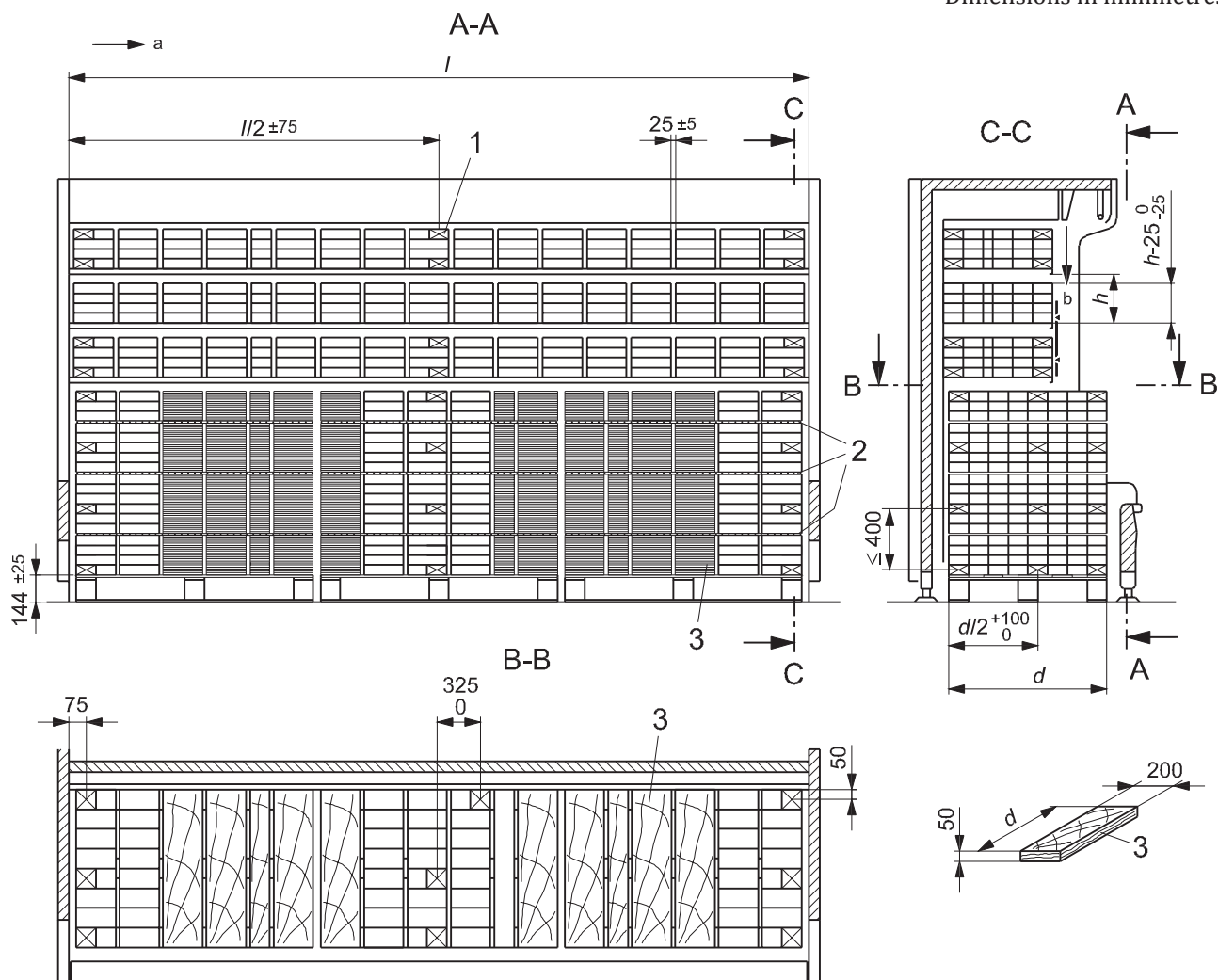

Key

- 1 M-package
- 2 grids
- 3 wood loading
- d* depth of base deck
- h* height at load limit
- l* length of the cabinet
- a* air currents parallel to the plane of the opening (in longitudinal direction)
- b* direction of forced air flow

Figure 26 — Roll-in and Multi-deck chilled cabinet (3 shelves) with high load limit in the base, provided with forced air cooling (vertical, open and closed)

Dimensions in millimetres

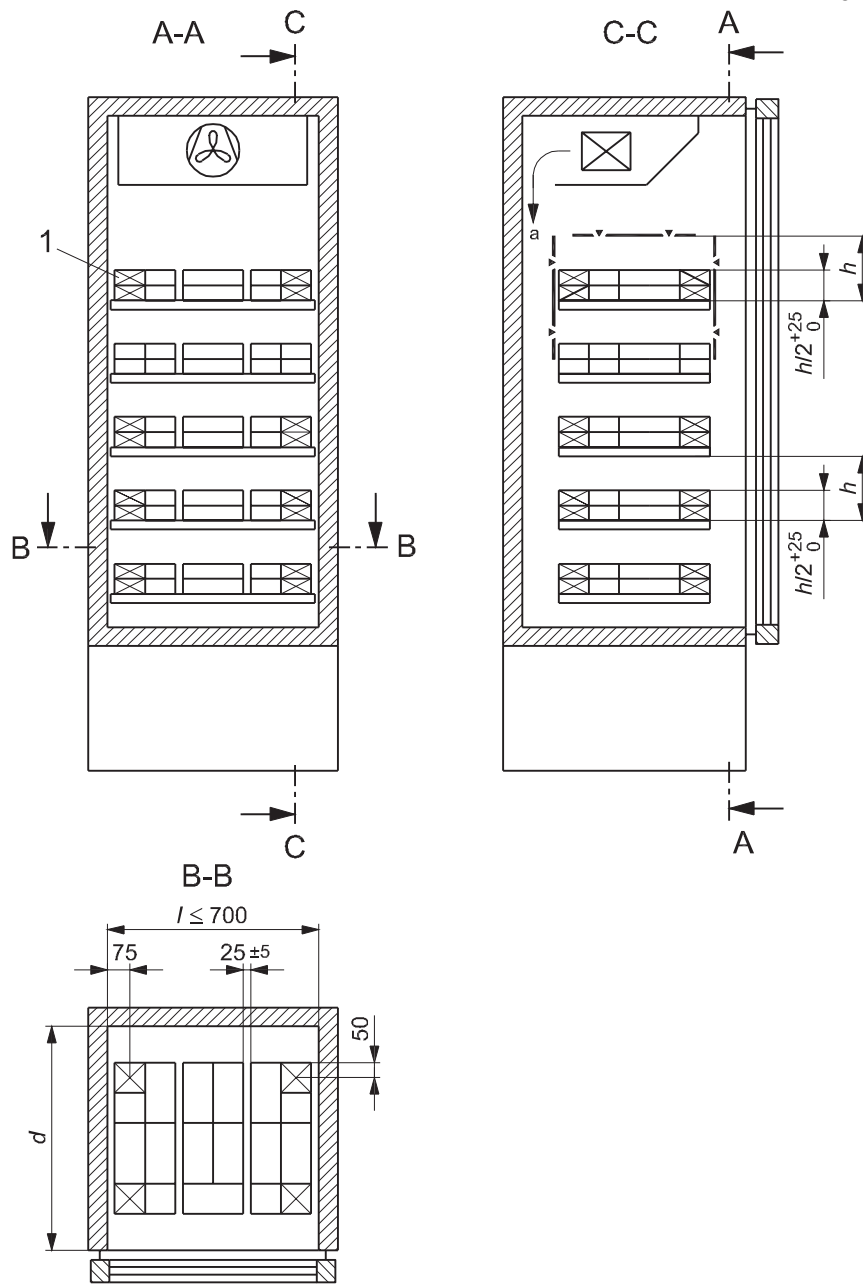

Key

- 1 M-package
- l length of cabinet
- d depth of base deck
- h height at load limit
- a direction of forced air flow

Figure 27 — Vertical frozen cabinet (4 shelves) with glass door

5.3.2.4 Running in

When a cabinet with a remote condensing unit is tested, the operating conditions should comply with those stated by the cabinet manufacturer.

Adjustable automatic controllers should be set in such a way that the required M-package temperature class of the cabinet is reached. Where the controller is not adjustable, the cabinet should be tested as delivered.

The manufacturer's recommended routine of defrosting should be followed. Before tests are started, the cabinet should be switched on and allowed to run for at least 2 h at the specified climate class with no packages in the cabinet and without erratic functioning of the refrigerating system, controls or defrosting operations. Otherwise, the running-in period should be continued accordingly.

After the running-in period the cabinet shall be filled with test packages and M-packages according to [5.3.2.3](#) for the tests.

After loading, the cabinet shall be operated until stable conditions have been reached (see [5.3.2.5](#)) and during the test period (see [5.3.2.6](#)) the test room should be maintained at the desired climate class as specified in [5.3.1](#), while the temperatures of the M-packages are recorded.

5.3.2.5 Stable conditions

The temperatures vary cyclically and the length of the cycle is dependent on the time between two successive defrost periods.

A cabinet is considered to operate under stable conditions if, during a period of 24 h, the temperature of each M-package agrees within $\pm 0,5$ °C at the corresponding points on the temperature curve. Changes or adjustments to the settings of the test room and to the cabinet during the stabilization period are not allowed.

For closed refrigerated cabinets, stable conditions shall be determined prior to the doors opening sequence (see [5.3.3.2](#)) and, if the cabinet is fitted with lighting, the lights shall be continuously left switched on.

For open refrigerated cabinets fitted with lighting and night covers, stable conditions are reached with the cabinet continuously opened with the light continuously switched on.

5.3.2.6 Test period

After stable conditions have been reached, the test period shall be not less than 24 h for all cabinets. Changes or adjustments to the settings of the cabinet during the test period are not allowed.

5.3.2.7 Lighting and night-covers

5.3.2.7.1 Lighting

If the test cabinet is fitted with lighting, carry out the tests according to [5.3.3](#), [5.3.4](#), [5.3.5](#) and [5.3.6](#) as follows:

- a) firstly, leave the cabinet lighting switched on continuously for a period of 24 h;
- b) secondly, leave the cabinet lighting switched on for a period of 12 h, followed by 12 h with cabinet lighting switched off.

5.3.2.7.2 Night-covers

If night-covers are supplied for open cabinets, carry out the tests as follows:

- a) firstly, with the night-covers removed, leave the cabinet lighting on continuously for a period of 24 h;
- b) secondly, with the night-covers removed, leave the cabinet lighting switched on for a period of 12 h, followed by 12 h with the night-covers on and the cabinet lighting switched off.

5.3.2.8 Accessories

An additional, separate test shall be conducted if performance-enhancing accessories are fitted, and this shall be stated in the test report (see [Clause 6](#)).

5.3.2.9 Liquid refrigerant inlet condition

The liquid refrigerant temperature at the cabinet inlet shall not be more than 10 °C above the specified test room temperature. During the test no “flash gas” condition shall occur. This shall be confirmed by observation.

5.3.2.10 Power supply

The tolerance on power supply shall be ± 2 % for voltage and ± 1 % for frequency in relation to the nominal values given on the marking plate or otherwise stated.

5.3.2.11 Testing several cabinets in the same room

If more than one cabinet in the same room is being tested, appropriate arrangements, such as the use of partitions, shall be made in order to ensure that the conditions surrounding each cabinet are in accordance with the test requirements specified in [5.3.1](#) to [5.3.2](#).

5.3.3 Temperature test

5.3.3.1 Test conditions

The cabinet shall be located and loaded in accordance with [5.3.1](#) and [5.3.2](#), operated in accordance with the manufacturer’s instructions at the conditions appropriate to the test room climate class for which it is intended (see [5.3.1.3.1](#)), and then operated for the test period defined in [5.3.2.6](#), during which measurements shall be recorded. Lighting, and night-covers, if any, shall be manipulated according to [5.3.2.7](#).

5.3.3.2 Closed refrigerated cabinets

The test for closed refrigerated cabinets shall always be carried out on the complete cabinet, regardless of the number of doors or lids. Each door or lid shall be opened for frozen food applications six times per hour, while for chilled food applications, each shall be opened 10 times per hour. Doors that are used for service, cleaning or loading of the cabinet only shall not be opened during this test. Where more than one door or lid pertains to the cabinet under test, the sequence in which the doors and lids are opened shall be staggered, i.e. in the case of two doors for frozen food applications: door 1 at 0 min, door 2 at 5 min, door 1 at 10 min, door 2 at 15 min, etc. For chilled food applications, door 1 at 0 min, door 2 at 3 min, door 1 at 6 min, door 2 at 9 min, etc.

Hinged lids and doors shall be opened beyond an angle of 60°. Sliding glass doors or lids shall be opened beyond 80 % of the maximum area which can be opened.

For frozen food applications, the door or lid shall be opened for a total of 6 s, while for chilled food applications, the door or lid shall be opened for a total of 15 s. During this opening period, the doors or lids shall be kept open beyond the minimum required opening, that is 4 s for frozen food applications and for 13 s for chilled food applications.

Prior to the start of the 12-h period of door opening, each door or lid shall be opened once for 3 min. Where a cabinet is provided with more than one door or lid, each door or lid shall be opened once for 3 min consecutively.

Within the test period, the doors or lids shall be opened cyclically for 12 h within 24 h. The 12-h cycle of door or lid opening shall start at the beginning of the test period.

For closed cabinets, only the test of [5.3.2.7.1 b](#)) is required.

5.3.3.3 Island with air discharge in the middle

5.3.3.3.1 The test for island with air discharge in the middle shall consider the following design variations:

- a) one chest, parts of the air distribution (fans, air ducts) and/or the refrigeration system (evaporator) are used for both sides of the cabinet;
- b) one chest, air distribution and refrigeration system are completely separated; the sides of the island are equal and symmetric; all electrical components (fan motors, anti-sweat heaters, defrost heaters), the evaporators and thermostatic expansion valves are the same in each refrigerated volume, and the temperature control system, such as the defrost control system, are symmetrically mounted and independently operative in each specific refrigerated volume.

Test procedure:

- For design variation a)

The piping has to be organized in such a way that the whole cabinet is connected to a single refrigeration plant by one main liquid and one main suction line. Even if the island has two evaporators with separate piping, the suction and the liquid lines shall be connected to two main lines (one suction, one liquid line) inside or outside the cabinet. All temperatures, pressure and mass flow measurements of the refrigerant shall be taken on the main lines. The piping shall be thermally insulated from the cabinet outlet to the locations where the measurements are taken. Both sides of the cabinet shall be loaded with M-packages and the temperature from both sides shall be monitored [see [Figure 28 a\)](#)].

- For design variation b)

Only one side of the cabinet may be tested considering it like a single case. Only the tested side(s) shall be loaded with M-packages and connected to the refrigerant plant [see [Figure 28 b\)](#)].

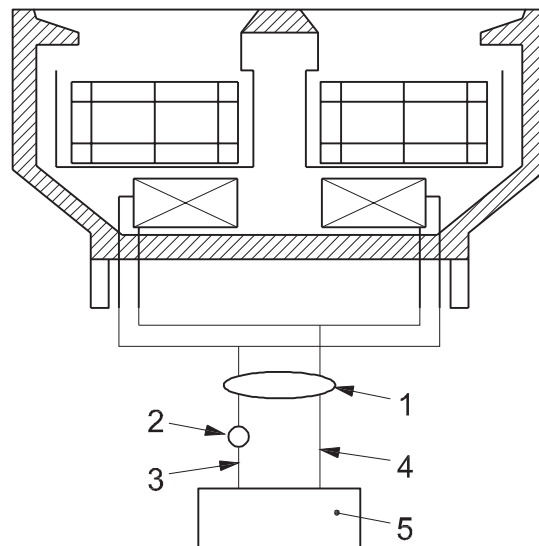

a) Design variation a)

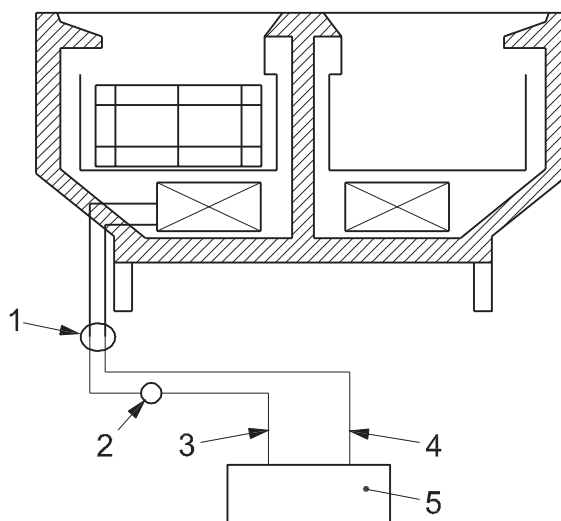

b) Design variation b)

Key

- 1 temperature and pressure measurements as in a single case (see 5.3.6.2.1 and Figure 30)
- 2 refrigeration mass flow meter (see 5.3.6.2.1 and Figure 30)
- 3 liquid supply (see 5.3.6.2.1 and Figure 30)
- 4 vapour return (see 5.3.6.2.1 and Figure 30)
- 5 condensing unit

Figure 28 — Island with air discharge in the middle

5.3.3.3.2 As far as DEC and REC measurement and calculations are concerned (see 5.3.6), the following shall be considered.

— For design variations b), single side test:

the total value of REC is double the value calculated for the single side tested;

the total value of DEC is double the value calculated for the single side tested.

— For design variations b), double side tests, follow design variation a).

— For the calculation of TDA, see Figure A.8.

5.3.3.4 Temperature curves of M-packages

From the recorded temperatures of all M-packages, the following curves shall be plotted as a function of time:

For frozen cabinets:

- 1) the temperature of the warmest M-package (i.e. the one with the highest peak temperature during defrost or door opening θ_{ah}) (see curve a - Figure 29);
- 2) the temperature that during test period T, excluding the periods during defrost or during the door openings, presents the highest minimum value θ_{al} (see curve c - Figure 29a);

For chilled cabinets:

- 3) the temperature of the warmest M-package (i.e. the one with the highest peak temperature θ_{ah}) (see curve a Figure 29b);

- 4) the temperature of the coldest M-package (i.e. the one with the lowest minimum temperature θ_b) (see curve b - [Figure 29b](#)).

All other M-package temperatures shall be available for reference if required.

In the case of cabinets with multiple temperature classes, curves a, b and c shall be prepared separately for each temperature class.

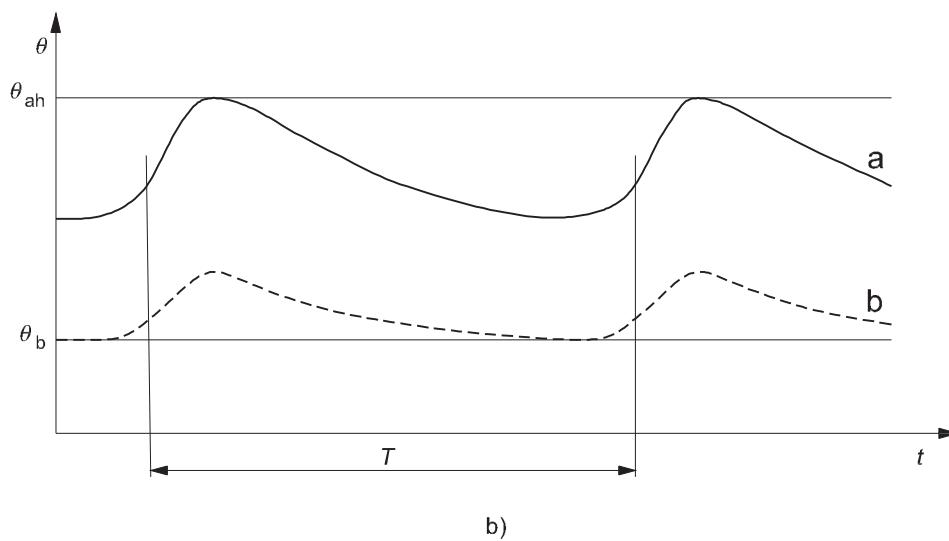
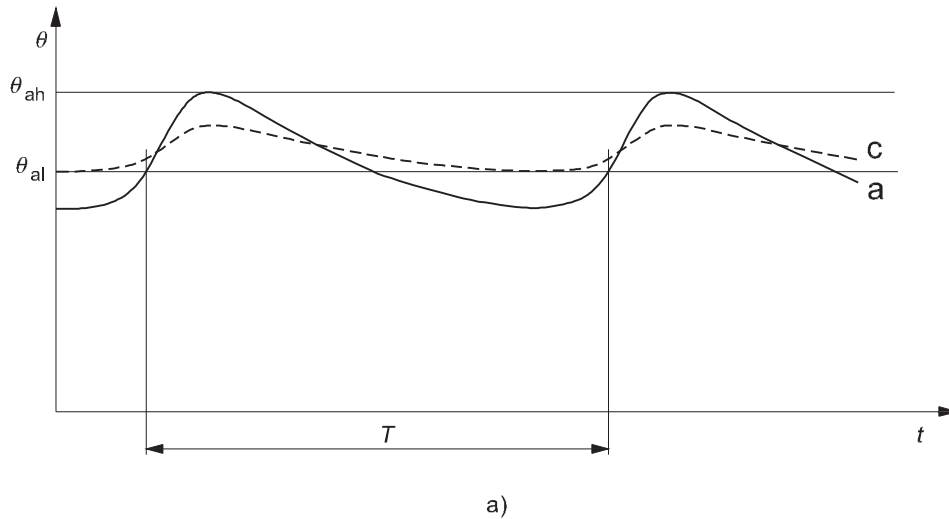

Key

- θ temperature
- θ_{ah} highest temperature of warmest M-package
- θ_b lowest temperature of coldest M-package [for chilled cabinets only; see [4.2.2 \(Table 1\)](#)]
- θ_{al} temperature that during test period T, excluding the periods during defrost or during the door openings, presents the highest minimum value see [4.2.2 \(Table 1\)](#)
- t time
- T test period
- a temperature curve of warmest M-package
- b temperature curve of coldest M-package
- c temperature curve with the highest minimum value of all M-package

Figure 29 — Relevant temperature curves of M-package

5.3.3.5 Calculation of average mean temperature

The average instant temperature at measuring sample n of all M-packages, θ_{cn} (curve d in [Figure 30](#)), is expressed by the Formula (1):

$$\theta_{cn} = \frac{1}{K_{\max c}} \times \sum_{k=1}^{K_{\max c}} (\theta_k)_n \quad (1)$$

where

n is the time index for the instant measuring sample;

k is the index for the individual M-package;

$K_{\max c}$ is the number of all M-packages;

$(\theta_k)_n$ is the instant measured temperature of M-package k at measuring sample n .

From these average instant temperatures the arithmetic mean temperatures of all M-packages θ_m for the test period shall be calculated as Formula (2):

$$\theta_m = \frac{1}{N_{\max}} \times \sum_{n=1}^{N_{\max}} \theta_{cn} \quad (2)$$

where N_{\max} is the number of measuring samples taken during the test period.

The formula is valid only for constant time intervals during the test period.

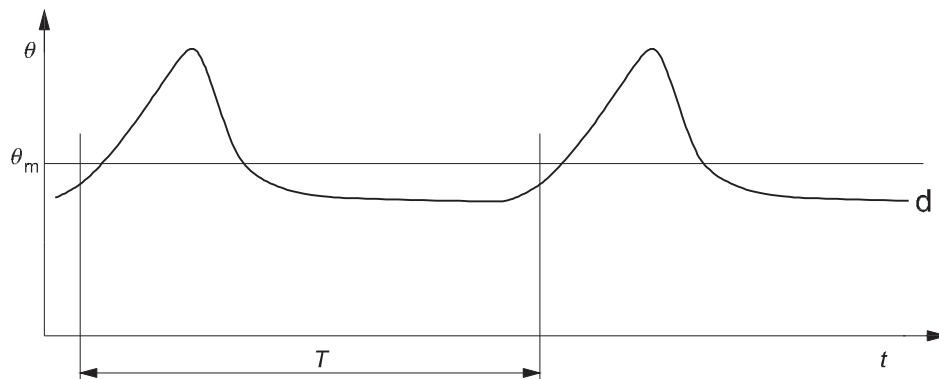

Key

θ temperature

θ_m average mean temperature

t time

T test period

d curve of arithmetic mean temperature of all M-packages

Figure 30 — Arithmetic mean temperature of M-packages

The arithmetic mean temperature of M packages curve d shall be plotted together with curves a, b and c and separately for each temperature class in the case of cabinets with multiple temperature classes.

5.3.4 Water vapour condensation test

5.3.4.1 Test conditions

The cabinet shall be located and loaded in accordance with 5.3.1 and 5.3.2, operated in accordance with the manufacturer’s instructions at the conditions appropriate to the test room climate class for which it is intended (see Table 3), and then operated for the test period according to 5.3.2.6, during which measurements shall be recorded. Lighting and night-covers, if any, shall be manipulated according to 5.3.2.7. The test may be carried out during the temperature test.

If anti-condensation heaters are provided which can be switched on and off by the user they shall not be switched on. If, however, running water appears externally when the cabinet is subjected to the water vapour condensation test, the test shall be repeated with the anti-condensation heaters switched on.

Before starting the test period, all external surfaces of the cabinet shall be carefully wiped dry with a clean cloth. If the cabinet is fitted with automatic defrosting equipment this test period shall be selected during the period when condensation is most likely to occur.

5.3.4.2 Test results

The cabinet shall be considered satisfactory if the test report shows that during the test period there is no evidence of condensed water vapour having been in direct contact with, or having dripped on to, any test packages and — depending on the method used to detect water vapour condensation — provided the following results have been obtained:

- a) all cabinet surfaces, whether adjacent or otherwise, remain free of moisture by the provision of insulation, ventilation or heating to maintain a temperature above dew point for the climate class specified (Table 3);
- b) internal surfaces, wherever practical, remain free of moisture collection or ice gather;
- c) mirrors that can periodically mist during defrost clear by evaporation on the return to refrigeration cycle.

5.3.4.3 Expression of results

During the test period, external surface areas exhibiting fog, droplets or running water shall be outlined and designated with the letters F, D and R respectively. A coded sketch shall be made showing the maximum area and degree of condensation appearing during the test on all surfaces; the code shown in Figure 31 shall be used.

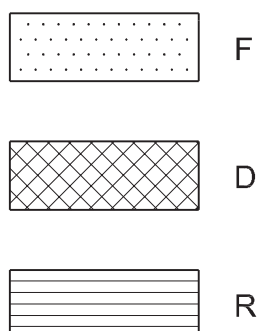

Key

- F fog/mist
- D droplets
- R running water

Figure 31 — Condensation code

5.3.5 Electrical energy consumption test

5.3.5.1 Test conditions

The cabinet shall be located and loaded in accordance with [5.3.1](#) and [5.3.2](#), operated in accordance with the manufacturer's instructions at the conditions appropriate to the test room climate class for which it is intended (see [Table 3](#)), and then operated for the test period according to [5.3.2.6](#), during which measurements shall be recorded. Lighting and night-covers, if any, shall be manipulated according to [5.3.2.7](#).

The test shall be carried out during the temperature test.

5.3.5.2 Cabinets fitted with incorporated condensing unit

For cabinets with an incorporated condensing unit the direct daily electrical energy consumption (DEC) equals the total daily energy consumption (TEC), as it includes the condensing unit energy consumption. Refrigeration daily electrical energy consumption (REC) is not defined for these cabinets.

Measure the TEC, including the condensing unit energy consumption, reported in kilowatt hours per 24-h period, the compressor switching on/off frequency and the relative running time (ratio of running time to overall duration of a measurement cycle excluding defrost time), with all fitted electrical power-using components switched on.

5.3.5.3 Cabinets with remote condensing unit

For cabinets with a remote condensing unit the DEC does not include the REC which shall be determined in accordance with [5.3.6](#).

Measure the DEC of the cabinet only, with all fitted electrical power-using components switched on.

The DEC recorded for each test shall be the summation of all electrical energy consumed by the refrigerated cabinet during the test period, without the control unit and, for indirect type refrigerating system, including the pump energy consumption CPEC.

NOTE If, for technical reasons, it is too difficult to measure separately the component powers, it is possible to use the DEC directly measured or the power consumed by any group of single components.

5.3.6 Heat extraction rate measurement when condensing unit is remote from cabinet

5.3.6.1 Test conditions

5.3.6.1.1 General

The cabinet shall be located and loaded in accordance with [5.3.1](#) and [5.3.2](#), operated in accordance with the manufacturer's instructions at the conditions appropriate to the test room climate class for which it is intended (see [Table 3](#)), and then operated for the test period according to [5.3.2.6](#), during which measurements shall be recorded. Lighting and night-covers, if any, shall be manipulated according to [5.3.2.7](#).

The test shall be carried out during the temperature test.

The refrigeration system shall be connected to the cabinet as given below.

The refrigerant inlet and outlet temperatures shall be measured using temperature sensors directly inserted into the pipe or inserted into pockets or clamped between the piping and a copper recovery half-sleeve on the inlet and outlet pipe-lines positioned no further than 150 mm from the cabinet wall [see [Figures 32 a](#)) and [33 a](#))].

Where thermocouples or similar devices are utilized, the sensor cables shall be arranged such that external influences on the connection cables are eliminated by the use of insulation.

Temperature sensors, connecting wires and pipelines shall be insulated from the outlet of the cabinet up to at least 150 mm beyond the measuring points.

A flow measuring device (flow meter) shall be installed in the liquid inlet supply line to the cabinet in order to measure mass flow rate of the liquid refrigerant.

A liquid sight glass shall be installed in the liquid piping downstream and, if necessary, optionally upstream of the flow meter in order to verify the vapour-free state of the refrigerant being supplied to the cabinet during the test period.

A temperature sensor shall be installed as stated above within, or at (150 ± 10) mm upstream of, the liquid flow meter, with the piping being insulated at least 150 mm upstream and from the sensor to the inlet of the flow meter.

A measurement of pressure shall be carried out at the cabinet outlet for compression type systems and both inlet and outlet for indirect type systems at less than 150 mm from the cabinet.

The heat extraction rate necessary for the cabinet shall be determined from temperature, pressure and flow rate readings which allow a resultant accuracy of ± 5 %.

5.3.6.1.2 Specific test conditions for cabinets intended for connection to compression-type refrigerating systems

The refrigeration system remotely located from the cabinet shall be connected to the cabinet in accordance with [Figure 32 a\)](#).

The refrigeration system selected for the test shall be capable of operating as follows:

- with the refrigerant at the saturated evaporating pressure or temperature in service at the cabinet outlet specified by the manufacturer;
- with the liquid refrigerant vapour free supplied at the cabinet inlet at a temperature not more than 10 °C above the specified test room temperature, or supplying sub-cooled liquid when specified.

In both conditions, the liquid temperature shall be stated.

An oil separator may be installed at the discharge of compressor to minimize the oil content of the refrigerant.

5.3.6.1.3 Specific test conditions for cabinets intended for connection to indirect-type refrigerating systems

The indirect-type refrigerating system shall be connected to the cabinet intended for this system in accordance with [Figure 33 a\)](#).

The refrigerating system shall be capable of supplying secondary refrigerant fluid at the temperature and flow rate specified by the manufacturer.

During defrost and cycling, the secondary refrigerant circulates through the bypass valves.

5.3.6.2 Determination of heat extraction rate

5.3.6.2.1 Cabinets intended for connection to compression-type refrigerating systems

See [Figure 33 a\)](#).

The instant heat extraction rate in kilowatts is defined as in Formula (3):

$$\Phi_n = q_m (h_8 - h_4) \tag{3}$$

for each individual measuring instant, where n indicates the measuring sample ($\Phi_n = 0$ kW during stopping and defrost time).

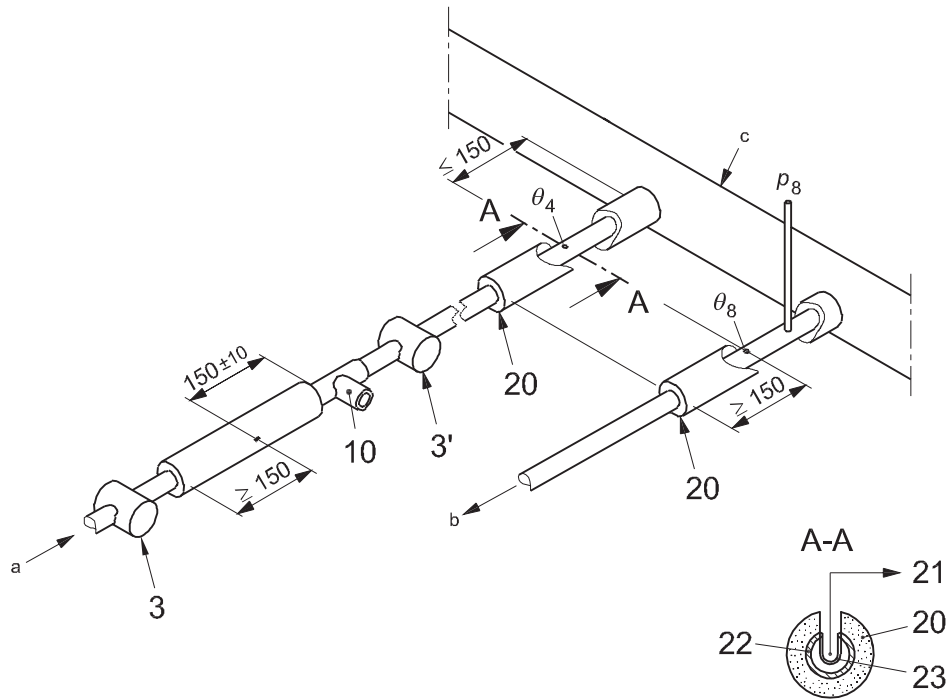

a) Connection to remote compression-type refrigerating system

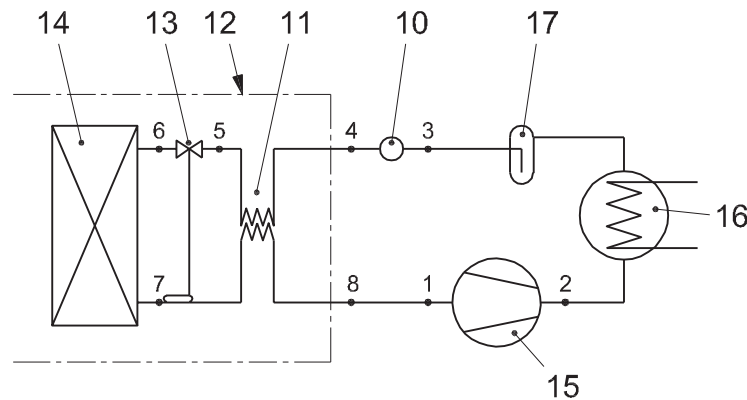

b) Connection to remote compression-type refrigerating system

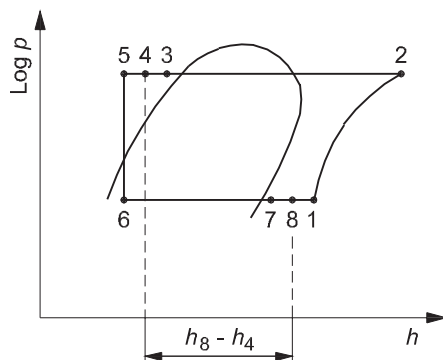

c) Pressure enthalpy diagram showing points referred to in [Figure 32 b\)](#)

Key

- | | | | |
|----|--|----|---|
| 1 | compressor inlet | 13 | expansion device |
| 2 | compressor outlet | 14 | evaporator |
| 3 | sight glass location for subcooled liquid state upstream flow meter | 15 | compressor |
| 3' | sight glass, optional for subcooled liquid state downstream flow meter | 16 | condenser |
| 4 | measurement point at the cabinet inlet | 17 | liquid receiver |
| 5 | expansion device inlet | 20 | insulation (to at least 150 mm from temperature sensor) |
| 6 | expansion device outlet and inlet of the evaporator | 21 | to temperature recorder |
| 7 | outlet of the evaporator and superheat measurement of the evaporator | 22 | refrigerant circulation pipe |
| 8 | measurement point at the outlet of the cabinet | 23 | copper thermo-pocket for housing the temperature sensor (shall be filled with glycerine or a similar fluid) |
| 10 | refrigerant mass flow meter | a | liquid supply |
| 11 | fluid vapour heat exchange, if any | b | vapour return |
| 12 | cabinet | c | cabinet wall |

Figure 32 — Cabinets intended for connection to compression-type refrigerating systems

5.3.6.2.2 Cabinets intended for connection to indirect-type refrigerating systems

See [Figure 33](#).

The instant heat extraction rate in kilowatts is defined as in Formula (4):

$$\Phi_n = q_m \left[(c_o \times \theta_o) - (c_i \times \theta_i) \right] \tag{4}$$

for each individual measuring instant, where n indicates the measuring sample ($\Phi_n = 0$ kW during stopping and defrost time).

Dimensions in millimetres

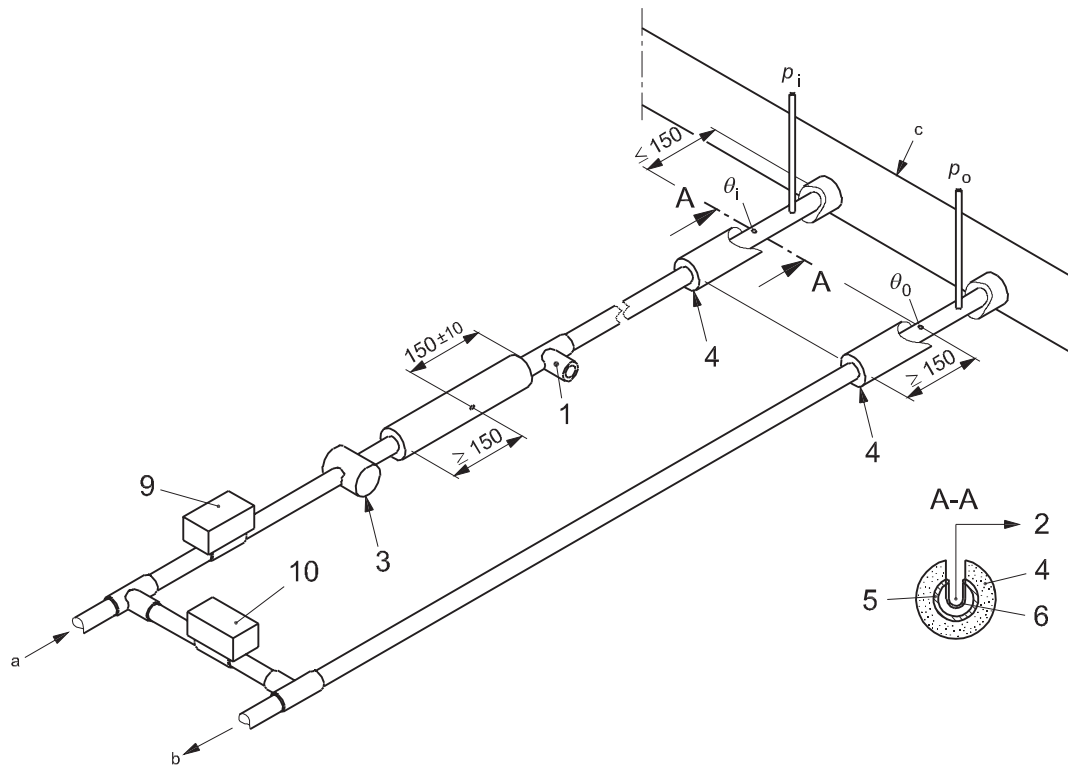

a) Connection to remote indirect-type refrigerating system

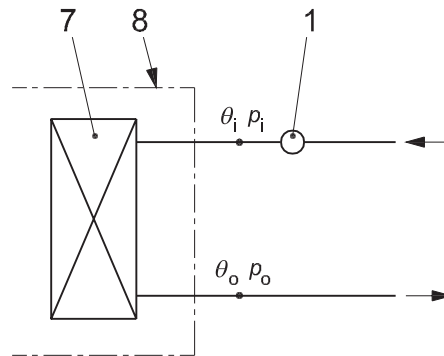

b) Reference point locations

Key

- | | | | |
|---|---|----|---|
| 1 | flow meter | 8 | cabinet |
| 2 | to temperature recorder | 9 | inlet valve: open during refrigeration, closed during switch off or defrosting |
| 3 | sight glass | 10 | outlet valve: closed during refrigeration, open during switch off or defrosting |
| 4 | insulation (to at least 150 mm from temperature sensor) | a | liquid supply |
| 5 | refrigerant circulation pipe | b | liquid return |
| 6 | copper thermo-pocket for housing the temperature sensor (shall be filled with glycerine or a similar fluid) | c | cabinet wall |
| 7 | heat exchanger | | |

Figure 33 — Cabinets intended for connection to indirect-type refrigerating systems

5.3.6.3 Method

5.3.6.3.1 General

The summation of the instant heat extraction rates Φ_n , in kilowatts, over 24 h gives the following.

Total heat extraction, Q_{tot} , in kilowatt hours (see [Figures 34](#) to [36](#)):

$$Q_{tot} = \sum_{n=1}^{n=N_{max}} \Phi_n \times \Delta t \quad (5)$$

where $\Phi_n = 0$ kW during stopping and defrost time.

The following shall be given when reporting the heat extraction rate for compression and indirect-type refrigerating systems:

- Φ_{24} the heat extraction rate necessary for a multi-cabinet installation in laboratory conditions, in kilowatts;
- $\Phi_{24\text{-defst}}$ the heat extraction rate for calculating the energy consumption of a cabinet in laboratory conditions, in kilowatts.

5.3.6.3.2 Determination of heat extraction rates

See [Figures 34](#) to [36](#).

The heat extraction rate necessary for a single cabinet installation, Φ_{run} , shall be calculated by arithmetic averaging of the instant heat extraction rates Φ_n during the running time only (t_{run}):

$$\Phi_{run} = \frac{Q_{tot}}{t_{run}} = \frac{Q_{tot}}{24 - t_{defst} - t_{stop}} \quad (6)$$

The heat extraction rate necessary for a multi-cabinet installation Φ_{24} shall be calculated by arithmetic averaging of the instant heat extraction rates during a whole day, including running, stopping and defrost times (t_{run} , t_{stop} and t_{defst}):

$$\Phi_{24} = \frac{Q_{tot}}{t_{run} + t_{stop} + t_{defst}} = \frac{Q_{tot}}{24} \quad (7)$$

A heat extraction rate for calculating the energy consumption of a cabinet $\Phi_{24\text{-defst}}$ shall be calculated by arithmetic averaging of the instant heat extraction rates during a whole day excepting defrost time (t_{defst}), e.g. only during running and stopping time (t_{run} and t_{stop}):

$$\Phi_{24\text{-defst}} = \frac{Q_{tot}}{t_{run} + t_{stop}} = \frac{Q_{tot}}{24 - t_{defst}} \quad (8)$$

The $\Phi_{24\text{-defst}}$ value shall be used in the REC calculation formula (see [5.3.6.3.3](#)).

5.3.6.3.3 Calculation of REC

The refrigeration daily electrical energy consumption for a cabinet intended for a remote compression-type refrigerating system, REC_{RC} , is calculated from the following Formula (9):

$$REC_{RC} = (24 - t_{defst}) \times \Phi_{24\text{-defst}} \times \frac{(T_c - T_{mrun})}{(0,34 \times T_{mrun})} = Q_{tot} \times \frac{(T_c - T_{mrun})}{(0,34 \times T_{mrun})} \quad (9)$$

with a constant condensing temperature of $T_c = 308,15$ K (35 °C, but calculation in Kelvin).

For a cabinet intended for an indirect type refrigerating system, the evaporation temperature T_{mrun} of the compression-type refrigerating system is lower than the secondary refrigerant temperature at the cabinet inlet (θ_i), and the evaporating temperature, which is not measured, shall be calculated as Formula (10):

$$T_{mrun} = \theta_i - 4K \quad (10)$$

Furthermore, electrical energy is consumed by the pump(s) necessary for circulating the secondary refrigerant. This consumption is not measured and is dependent on the practical design of the secondary refrigerant circuit. As a conventional rule, the pumping daily energy consumption (CPEC) in kilowatt hours per 24-h period is calculated using the following equation; assuming a pressure drop in the system equalling 2,5 times the pressure drop over the cabinet and a pump efficiency of 0,5:

$$CPEC = v\tau \frac{2,5q_{mrun}(P_{irun} - P_{orun})}{0,5} \quad (11)$$

The factor τ in the above formula represents the running time of the pump in hours per day. As a conventional rule, τ is established as follows:

- for systems with hot brine defrost, $\tau = 19$ (h/day);
- for all other systems, $\tau = 18$ (h/day).

Due to a lack of sufficient (measured) data, the prescribed values for τ shall be seen as preliminary choices that could need alteration.

The value of CPEC as above defined shall be added to the Direct Cabinet Consumption DEC (see [5.3.5.3](#)).

The refrigeration daily electrical energy consumption for a cabinet intended for a remote indirect refrigerating system, REC_{RI} , in kilowatt hours per 24-h period is calculated from the following Formula (12):

$$REC_{RI} = \left[(24 - t_{def}) \times \dot{V}_{24-def} + 0,5CPEC \right] \times \frac{(T_c - T_{mrun})}{(0,34 \times T_{mrun})} \quad (12)$$

with a constant condensing temperature of $T_c = 308,15$ K (35 °C).

NOTE For both direct and indirect systems, the calculated refrigeration daily electrical energy consumption refers to a standard refrigeration plant. Although the actual energy consumption of a refrigeration plant is generally not equal to that of the standard plant, it can be mathematically proven that the “ranking order” of cabinets remains the same.

5.3.6.3.4 Calculation of TEC

The total daily electrical energy consumption expressed in kWh/24h is calculated from the Formula (13):

$$TEC = DEC + REC \quad (13)$$

5.3.6.3.5 Calculation of SEC

The value of SEC representing the Specific Daily Electrical Energy Consumption for a Refrigerated Display Cabinet is calculated from the Formula (14):

$$SEC = TEC / TDA \quad (14)$$

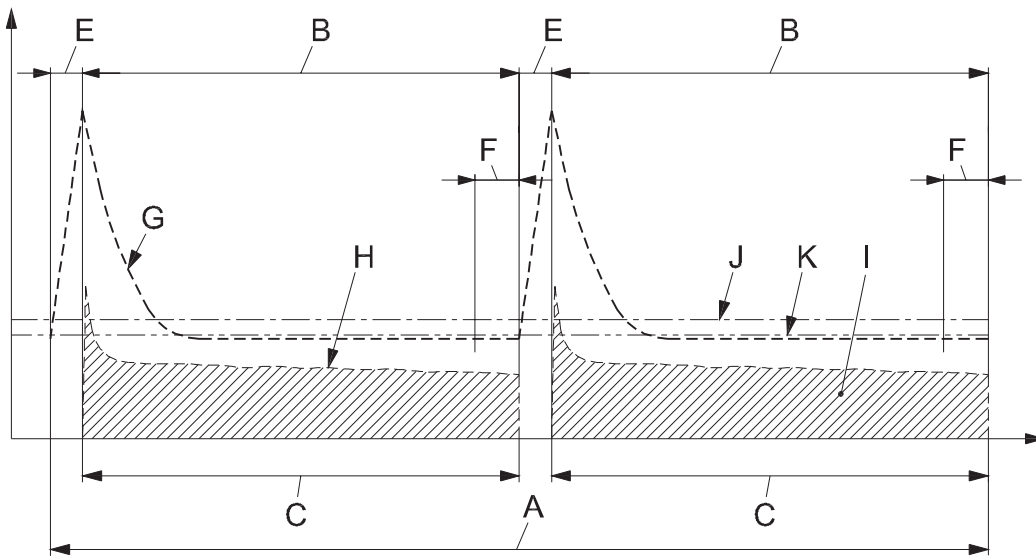

a) Constant evaporating pressure, no cycling

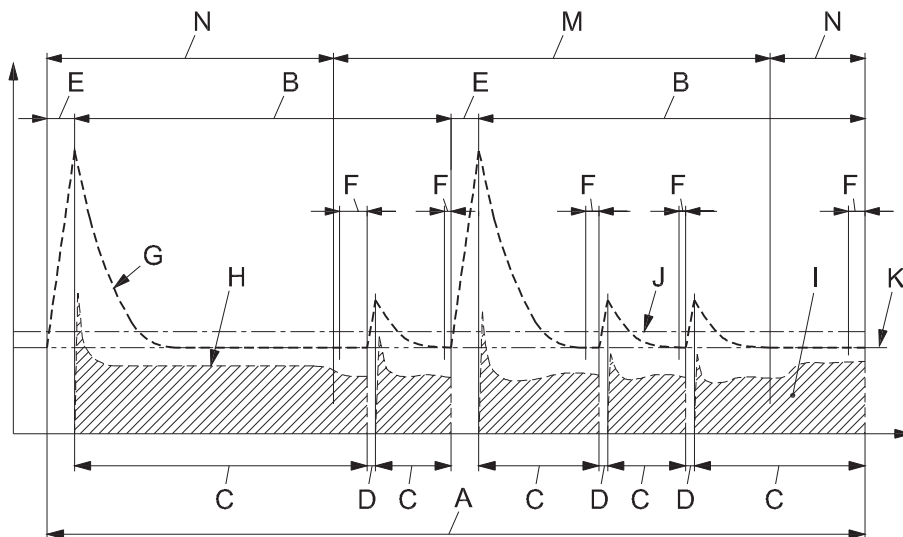

b) Constant evaporating pressure, no cycling, and cycling with night covers on

Key

- | | | | |
|---|---|---|--|
| A | 24 h (ref.) | H | instant heat extraction rate (Φ_n) |
| B | refrigerating period (ref.) | I | total heat extraction (Q_{tot} = area under graph) |
| C | running time (t_{run}) | J | average of evaporator saturated temperature (θ_{mrun}) |
| D | off time (t_{stop}) | K | average of evaporator saturated temperature during last 10 % of running periods (θ_{min}) |
| E | defrost off period (t_{defl}) | M | night covers on 12 h |
| F | running time for reporting minimum evaporating temperature ($t_{run} \cdot 10\%$) | N | night covers off 12 h |
| G | evaporating temperature | | |

Figure 34 — Refrigeration cycle — Constant evaporating pressure — No cycling

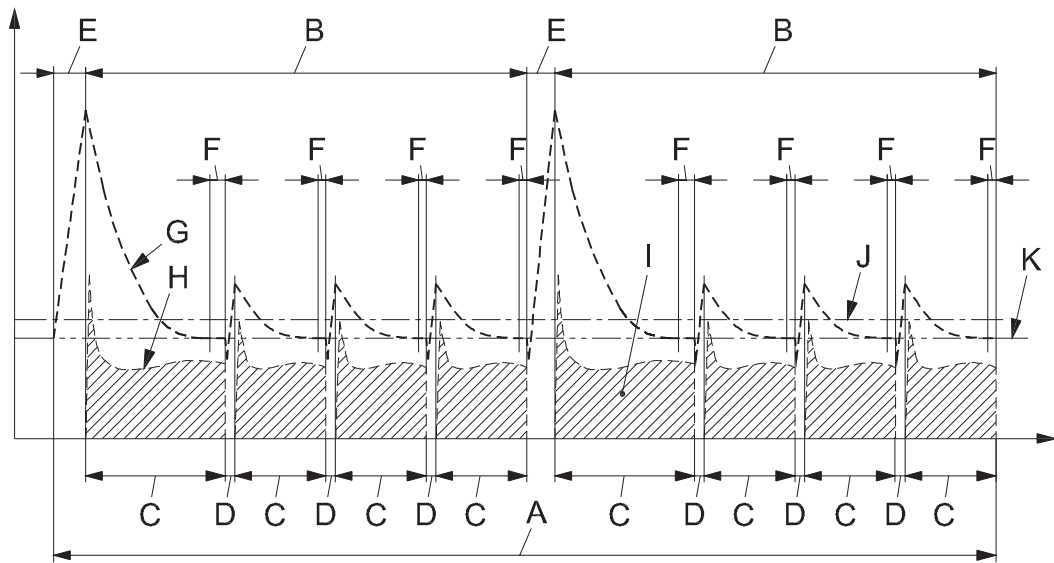

Key

- | | | | |
|---|---|---|--|
| A | 24 h (ref.) | G | evaporating temperature |
| B | refrigerating period (ref.) | H | instant heat extraction rate (Φ_n) |
| C | running time (t_{run}) | I | total heat extraction (Q_{tot} = area under graph) |
| D | off time (t_{stop}) | J | average of evaporator saturated temperature (θ_{mrun}) |
| E | defrost off period (t_{defl}) | K | average of evaporator saturated temperature during last 10 % of running periods (θ_{min}) |
| F | running time for reporting evaporating minimum temperature ($t_{run} \cdot 10\%$) | | |

Figure 35 — Refrigeration cycle — Cycling including pump down

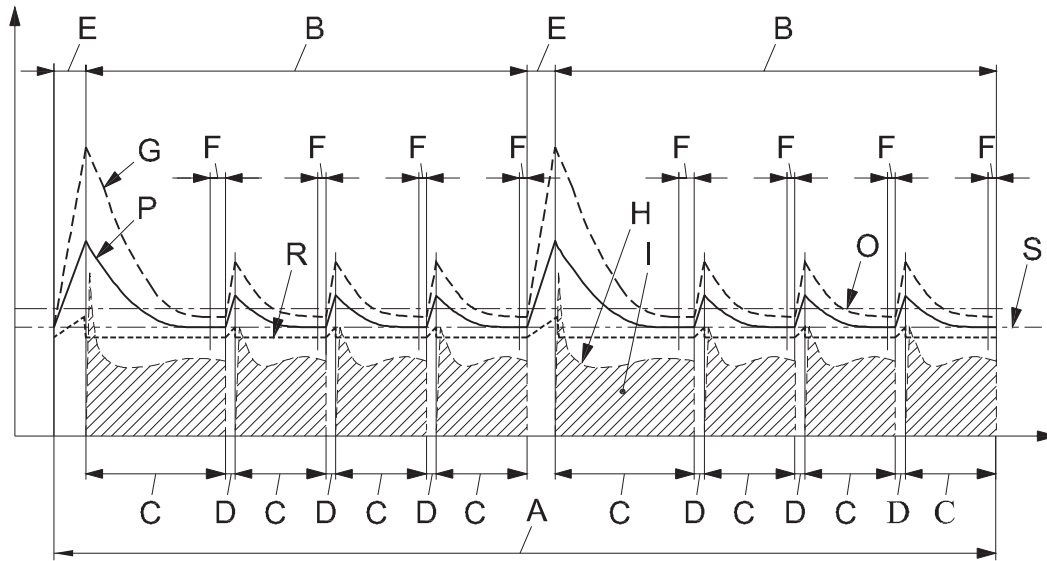

Key

- | | | | |
|---|---|---|---|
| A | 24 h (ref.) | H | instant heat extraction rate (Φ_n) |
| B | refrigerating period (ref.) | I | total heat extraction (Q_{tot} = area under graph) |
| C | running time (t_{run}) | O | secondary refrigerant inlet temperature (θ_i) |
| D | off time (t_{stop}) | P | secondary refrigerant median temperature (θ) |
| E | defrost off period (t_{defl}) | R | average of secondary refrigerant median temperature (θ_{mrun}) |
| F | running time for reporting evaporating minimum temperature ($t_{run} \cdot 10\%$) | S | average of secondary refrigerant median temperature during last 10% of running periods (θ_{min}) |
| G | secondary refrigerant outlet temperature (θ_o) | | |

Figure 36 — Refrigeration cycle with secondary refrigerant with cycling

6 Test report

6.1 General

For each test carried out, general information and specific test results shall be given as follows.

NOTE For information to be given on the cabinet, see [7.2](#).

6.2 Tests outside test room

6.2.1 Seal test of doors and lids

According to [5.2.1](#).

Test that the doors or lids seal effectively.

6.2.2 Linear dimensions, areas and volumes

According to [5.2.2](#).

See [Table 7](#).

Table 7 — Linear dimensions, areas and volumes

Description	Symbol	Unit	Number of decimal places
Overall external dimensions at installation	L, H, W	mm	0
Overall external dimensions in service		mm	0
Refrigerated shelf area for each declared temperature class		m ²	2
Display opening area		m ²	2
Total display area	TDA	m ²	2
Sneeze guard, see Figure 1	A + B	mm	0

6.2.3 Test for absence of odour and taste

(if applicable)

See [Annex C](#).

6.3 Tests inside test room

6.3.1 General test conditions

According to [5.3.1](#).

See [Table 8](#).

Table 8 — Conditions for tests inside test room

Subclause no.	Description
5.3.1.1	Statement that the test room, test packages, filling material (wood loading), M-packages and the instrumentation used are in accordance with 5.3.1 specifying if alternative for filling test packages described in 5.3.1.6 are used.
5.3.1.3	Test room climate class for which the cabinet is intended and in which the test has been made.

6.3.2 Cabinet preparation

See [Table 9](#).

Table 9 — Cabinet preparation for tests inside test room

Subclause no.	Description	Symbol	Unit
5.3.2.1	The cabinet location within the test room using the Figure 8 presentation.	X, B, Y, A	mm
5.3.2.1	For cabinets intended to be placed against a wall, the location of the vertical partition at the rear of the cabinet.	d _p	mm
5.3.2.3	Number of the figure according to which the cabinet was loaded.		
5.3.2.4	The method of temperature control, defrost process, defrost termination, setting parameters and sensor locations.		
5.3.2.7	Whether the test was made with or without night-covers and/or light.		
5.3.2.6	Whether the test was made using alternative filling test packages as specify in 5.3.1.6 .		

Table 9 (continued)

Subclause no.	Description	Symbol	Unit
5.3.2.9	When the condensing unit is remote from the cabinet for compression-type refrigerating systems the international number of the refrigerant (see ISO 817).		
5.3.2.9	When the condensing unit is remote from the cabinet for indirect-type refrigerating systems:		
	chemical composition of the secondary refrigerant;		
	concentration of the secondary refrigerant.		
	The physical properties of the secondary refrigerant:		
	specific heat at the cabinet inlet/outlet;	c_i/c_o	kJ/kg/K
	Density.	ρ	kg/m ³

6.3.3 Temperature test

According to [5.3.3](#).

See [Table 10](#).

Table 10 — Temperature test for tests inside test room

Subclause no.	Description	Symbol	Unit
5.3.3.1	For cabinets fitted with night-covers and/or lights, if the results are for the “a)” or the “b)” test of 5.3.2.7.1 and 5.3.2.7.2 or for both tests (two sets of results shall be provided for the latter case)		
5.3.3.2	The time/temperature curves of the warmest and the coldest M-packages and the extreme values θ_{ah} , θ_b and if necessary θ_{al} and the resulting cabinet classification (see 4.2.2 Table 1 , 5.3.3.4 and Figure 29)	θ_{ah} θ_b θ_{al}	°C
5.3.3.5	The average mean temperatures of all M-packages (see also 5.3.3.4 and Figure 30)	θ_m	°C
5.3.3.4	For temperature display systems, the sensor location and the maximum values displayed		
	under stable operating conditions, and		°C
	at the warmest moment, during or just after the defrost period.		°C
	Conditions where the display of temperature may be interrupted (e.g. during defrosting)		

6.3.4 Water vapour condensation test

According to [5.3.4](#).

See [Table 11](#).

Table 11 — Water vapour condensation test

Subclause no.	Description	Symbol	Unit
5.3.4.1	For cabinets fitted with night-covers and/or lights, state whether the results are for the "a)" or the "b)" test of 5.3.2.7.1 and 5.3.2.7.2 or for both tests. Two sets of results shall be provided in the latter case		
5.3.4.1	Whether any manual switch provided for anti-condensation heaters was switched off		
5.3.4.2	The duration of the period of observation		h
	Coded sketches as defined in 5.3.4.3		

6.3.5 Electrical energy consumption test

According to [5.3.5](#).

See [Table 12](#).

Table 12 — Electrical energy consumption test

Subclause no.	Description	Symbol	Unit
5.3.5.1	For cabinets fitted with night-covers and/or lights, state whether the results are for the "a)" or the "b)" test of 5.3.2.7.1 and 5.3.2.7.2 or for both tests. Two sets of results shall be provided in the latter case		
5.3.5.2	For cabinets fitted with integral condensing unit:		
	direct electrical energy consumption (= total electrical energy consumption)	<i>DEC</i> <i>(TEC)</i>	kWh/24 h
	compressor switching on/off frequency		
	relative running time		
5.3.5.3	For cabinets with remote condensing unit:		
	direct electrical energy consumption	<i>DEC</i>	kWh/24 h

6.3.6 Heat extraction rate measurement when the condensing unit is remote from the cabinet

According to [5.3.6](#).

See [Table 13](#).

Table 13 — Heat extraction rate measurement when the condensing unit is remote from the cabinet

Subclause no.	Description	Symbol	Unit
5.3.6.1.1	For cabinets fitted with night-covers and/or lights, state whether the results are for the "a)" or the "b)" test of 5.3.2.7.1 and 5.3.2.7.2 or for both tests. Two sets of results shall be provided in the latter case		

Table 13 (continued)

Subclause no.	Description	Symbol	Unit
5.3.6.1.2 See Figures 32, 34 and 35	For compression-type refrigerating systems:		
	curves and mean values of the suction pressure, in service, and the refrigerant temperature at the cabinet outlet	p_8 θ_8	Pa °C
	mean value of the saturated evaporator temperature during the running time and during the last 10 % of all running periods	θ_{mrun} θ_{min}	°C °C
	arithmetic mean suction superheat at the cabinet outlet		°C
	arithmetic mean suction superheat at the evaporator outlet		°C
	curve and mean value of the liquid temperature at the cabinet inlet	θ_4	°C
	curve and mean value of the mass flow rate of refrigerant	q_m	kg/s
5.3.6.1.3 See Figures 33 and 36	For indirect refrigerating systems:		
	curve and mean value of the secondary refrigerant temperature at the cabinet inlet	θ_i	°C
	curve and mean value of the secondary refrigerant temperature at the cabinet outlet	θ_o	°C
	mean value of the median temperature of the secondary refrigerant during the running time	θ_{mrun}	°C
	mean value of the median temperature of the secondary refrigerant during the last 10 % of all running periods	θ_{min}	°C
	curve and mean value of the mass flow rate	q_m	kg/s
	pressure drop between the inlet and outlet of the cabinet excluding valves not fitted by the manufacturer as part of the cabinet	$p_{irun} - p_{orun}$	Pa
5.3.6.3	Heat extraction rates necessary for the cabinet which result from the foregoing measurements:	Φ_{run}	
	heat extraction rate during the running time only		kW
	heat extraction rate during a whole day, including running, stopping and defrost times	Φ_{24}	kW
	heat extraction rate during a whole day excepting defrost time	$\Phi_{24-defst}$	kW
	refrigeration daily electrical energy consumption	REC	kWh/24 h
	total daily electrical energy consumption	TEC	kWh/24 h
	specific daily electrical energy consumption	SEC	kWh/24h*m ²
	for cabinets where cycling of the system is necessary for operational reasons, the percentage running time	t_{rr}	%

7 Marking

7.1 Load limit

Every cabinet shall be clearly and permanently marked with one or several load limit line(s) [see [Figure 37 b\)](#)], on the inside face, as shown in [Figure 39](#), to denote the load limit. Where it is not possible to exceed the load limit, no marking is required.

The load limit line shall be continuous [see [Figure 37 a\)](#)], or repeated at intervals [[Figure 37 b\)](#)] to ensure that it cannot be overlooked. Individual markings shall be at least 50 mm long and shall contain at least one equilateral triangle with side dimension, d_1 , included within 5,5 mm and 15 mm (see [Figure 38](#)).

Where a load limit line cannot be marked on the inside face because of cabinet design, an outline sketch showing the load limit shall be fixed in a visible position and in the manufacturer's instruction handbook.

Dimensions in millimetres

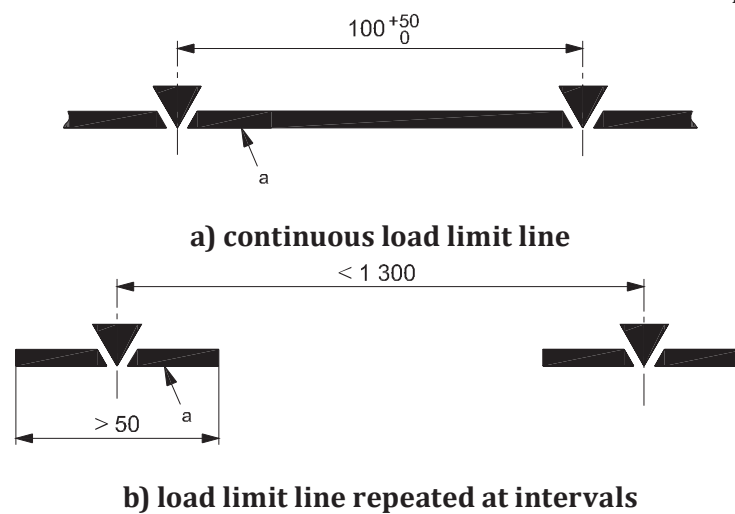

Key

a This denotes the load limit.

Figure 37 — Load limit markings

Dimensions in millimetres

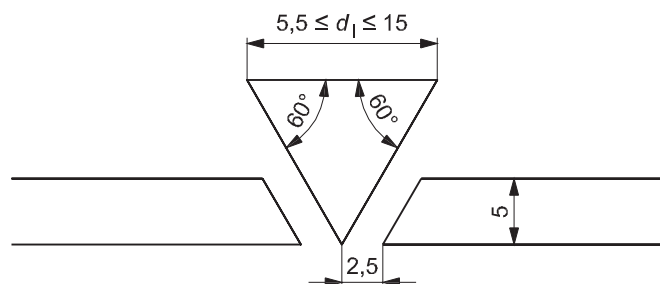

Figure 38 — Dimensions of load limit line

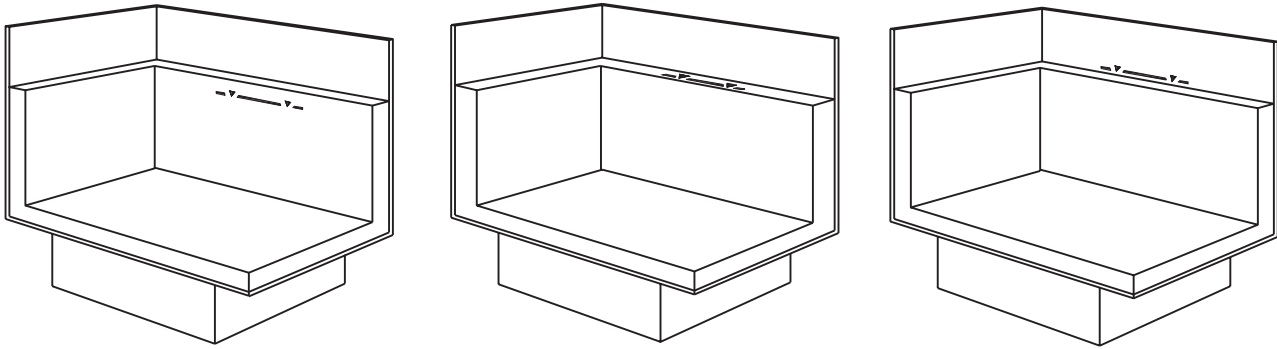

Figure 39 — Different positions for the load limit

7.2 Marking plate

Each cabinet shall have the following information marked in a permanent and legible manner in locations where it is readily accessible:

- a) the manufacturer's name or trademark or both (not necessarily the same name as that of the condensing unit);
- b) model and serial number of the cabinet, integral condensing unit(s), etc., or sufficient information to provide adequate identification for replacement of parts or necessary servicing;
- c) a description of the cabinet's internal fittings;
- d) all information relating to the power supply for which the cabinet is designed;
- e) for cabinets with integral condensing unit, the international number of refrigerant(s) (see ISO 817) used and its (their) mass;
- f) for cabinets having remote condensing units, marking in accordance with ISO 5149-2.

7.3 Information to be supplied by the manufacturer

The following information shall be provided by the manufacturer for each cabinet model.

- a) Overall external dimensions at installation.
- b) Overall external dimensions in service including: distance d_p between the back of the cabinet and the vertical test panel if applicable (see [5.3.2.1](#))
- c) The intended cabinet classification/s (see ISO 23953-1, 3.6.5) and for each class the following information:
 - 1) the display opening area;
 - 2) total display area (see [Annex A](#));
 - 3) where applicable, the refrigerated shelf area;
 - 4) the maximum load, in kilograms, permitted on the trays and shelves and in the baskets or on the base deck for the various methods of arranging them in the cabinet;
 - 5) the direct daily electrical energy consumption (DEC), in kilowatt hours per 24 h, measured in accordance with the test described in [5.3.5](#),
 - 6) the specific daily electrical energy consumption SEC; in kilowatt hours per 24 h per m^2 of total display area

- 7) if the condensing unit is not fitted in the refrigerated cabinet, the information referred to heat extraction rate according to [5.3.6](#).

NOTE For temperature and climate classes, see [4.2.2](#) and [5.3.1.3.1](#).

- 8) for cabinets fitted with night-covers and/or lights, if the results are for the “a)” or the “b)” test of [5.3.2.7.1](#) and [5.3.2.7.2](#) or for both tests, in the latter case with two sets of information being provided for 5), 6) and 7)
- 9) location of the temperature sensor;
- 10) maximum values displayed by the instrument or measured at the sensor location in stable operating conditions;
- 11) maximum value displayed by the instrument or measured at the sensor location at the warmest moment during or just after the defrosting period;
- 12) conditions where the display of temperature may be interrupted (for example during defrosting).

Annex A (normative)

Total display area (TDA)

A.1 General

The TDA is determined by the sum of vertical and horizontal projected areas from visible foodstuff, in square metres. For multi-deck and semi-vertical cabinets, the horizontal projected area is measured from a plane located at 1,55 m from the ground in order to take into account the visible foodstuffs located in the front part of the shelves (see [Figure A.3](#)).

A.2 Measurement of TDA in a refrigerated display cabinet

A.2.1 Calculation of TDA

The total display area shall be calculated as in Formula (A.1):

$$TDA = (H_o \times L_{oh}) + (H_g \times L_{gh}) + (V_o \times L_{ov}) + (V_g \times L_{gv}) \quad (A.1)$$

where

- H is the horizontal projection, in metres;
- V is the vertical projection, in metres;
- L is the cabinet length without end walls, in metres;
- index o is the open surface;
- index g is the glazing surface;
- index h is the horizontal;
- index v is the vertical;
- index t is the top
- index b is the base
- index w is the end wall.

NOTE 1 Price rails are not considered in the calculation of the TDA as their visibility is equally important to that of foodstuff.

NOTE 2 The opaque areas of the frames, hand rails or handles shall be deducted from the measurement.

[Figures A.1](#) to [A.9](#) illustrate the calculation for the most common cabinets with a length of 2,5 m.

Dimensions in metres

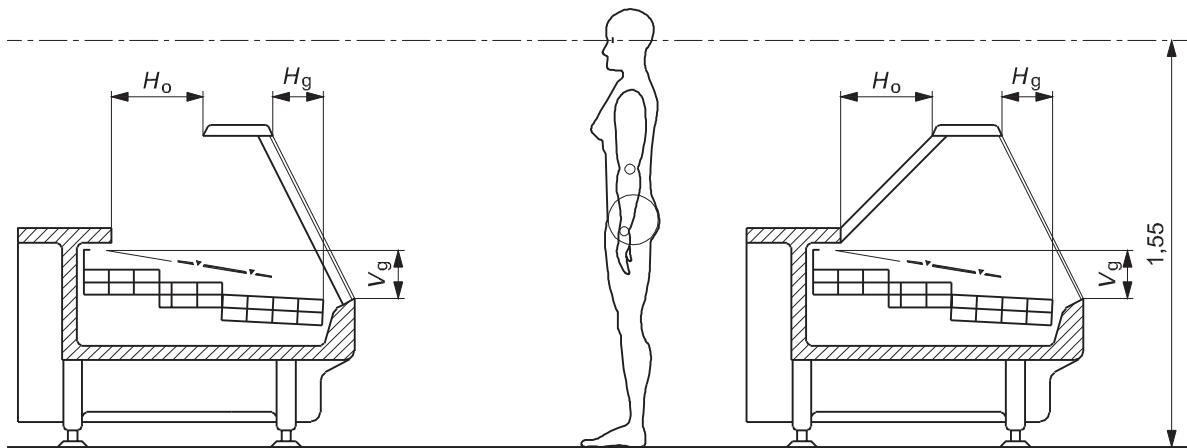

$L_{oh} = 2,500$	$H_o = 0,291$	$L_{oh} = 2,400$	$H_o = 0,350$	
$L_{gh} = 2,500$	$H_g = 0$	$L_{gh} = 2,500$	$H_g = 0,194$	
$L_{ov} = 2,500$	$V_o = 1,367$	$L_{ov} = 2,500$	$V_o = 0$	
$L_{gv} = 2,500$	$V_g = 0$	$L_{gv} = 2,500$	$V_g = 0,185$	
TDA = $(H_o \times L_{oh}) + (H_g \times L_{gh}) + (V_o \times L_{ov}) + (V_g \times L_{gv})$		1,785	TDA = $(H_o \times L_{oh}) + (H_g \times L_{gh}) + (V_o \times L_{ov}) + (V_g \times L_{gv})$	
			1,788	

Figure A.1 — Horizontal, serve-over counters

Dimensions in metres

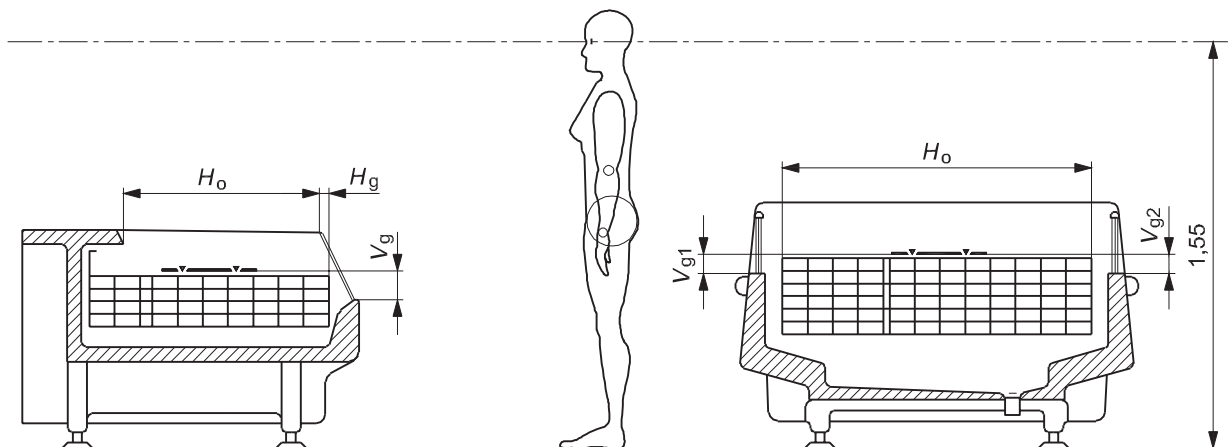

		$L_{oh} = 2,500$	$H_o = 1,176$	
$L_{oh} = 2,500$	$H_o = 0,770$	$L_{gh} = 2,500$	$H_g = 0$	
$L_{gh} = 2,500$	$H_g = 0,012$	$L_{ov} = 2,500$	$V_o = 0$	
$L_{ov} = 2,500$	$V_o = 0$	$L_{gv1} = 2,400$	$V_{g1} = 0,058$	
$L_{gv} = 2,500$	$V_g = 0,090$	$L_{gv2} = 2,400$	$V_{g2} = 0,058$	
TDA = $(H_o \times L_{oh}) + (H_g \times L_{gh}) + (V_o \times L_{ov}) + (V_g \times L_{gv})$		2,18	TDA = $(H_o \times L_{oh}) + (H_g \times L_{gh}) + (V_o \times L_{ov}) + (V_{g1} \times L_{gv1}) + (V_{g2} \times L_{gv2})$	
			3,218	

Figure A.2 — Horizontal, open, wall-site and island cabinets

Dimensions in metres

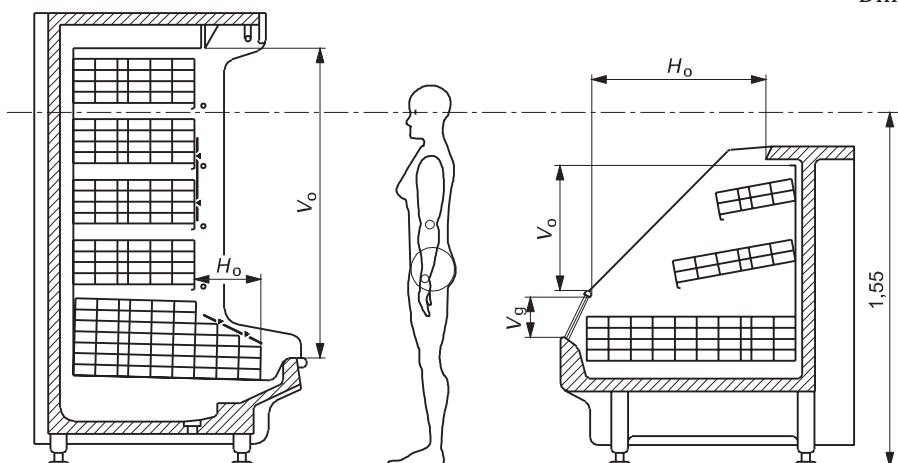

$L_{oh} = 2,500$	$H_o = 0,291$	$L_{oh} = 2,500$	$H_o = 0,761$
$L_{gh} = 2,500$	$H_g = 0$	$L_{gh} = 2,500$	$H_g = 0$
$L_{ov} = 2,500$	$V_o = 1,367$	$L_{ov} = 2,500$	$V_o = 0,546$
$L_{gv} = 2,500$	$V_g = 0$	$L_{gv} = 2,400$	$V_g = 0,175$
$TDA = (H_o \times L_{oh}) + (H_g \times L_{gh}) + (V_o \times L_{ov}) + (V_g \times L_{gv})$		4,145	$TDA = (H_o \times L_{oh}) + (H_g \times L_{gh}) + (V_o \times L_{ov}) + (V_g \times L_{gv})$
			3,688

Figure A.3 — Vertical, multi-deck and semi-vertical cabinets

Dimensions in metres

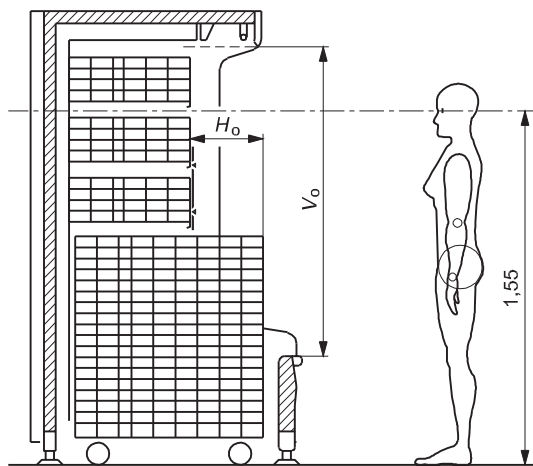

$L_{oh} = 2,500$	$H_o = 0,321$
$L_{gh} = 2,500$	$H_g = 0$
$L_{ov} = 2,500$	$V_o = 1,367$
$L_{gv} = 2,500$	$V_g = 0$
$TDA = (H_o \times L_{oh}) + (H_g \times L_{gh}) + (V_o \times L_{ov}) + (V_g \times L_{gv})$	
4,220	

Figure A.4 — Vertical, roll-in cabinet

Dimensions in metres

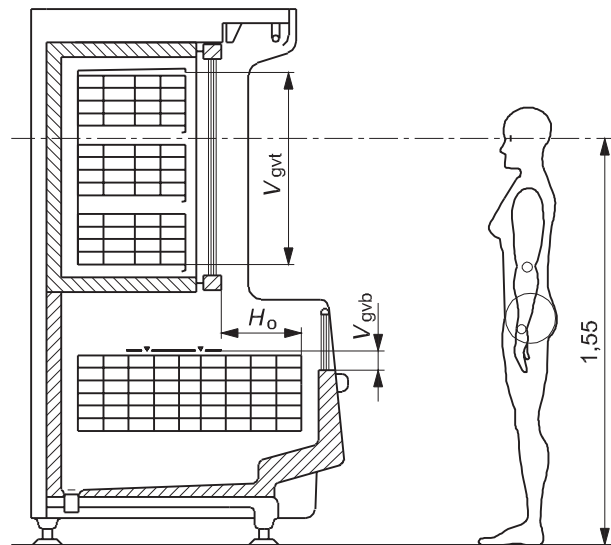

$L_{oh} = 2,500$	$H_o = 0,306$
$L_{gh} = 2,500$	$H_g = 0$
$L_{ov} = 2,500$	$V_o = 0$
$L_{gvt} = 2,250$	$V_{gt} = 0,731$
$L_{gvb} = 2,400$	$V_{gb} = 0,058$
$TDA = (H_o \times L_{oh}) + (H_g \times L_{gh}) + (V_o \times L_{ov}) + (V_{gt} \times L_{gvt}) + (V_{gb} \times L_{gvb})$	
2,549	

Figure A.5 — Combined, glass door top, open bottom, cabinet

Dimensions in metres

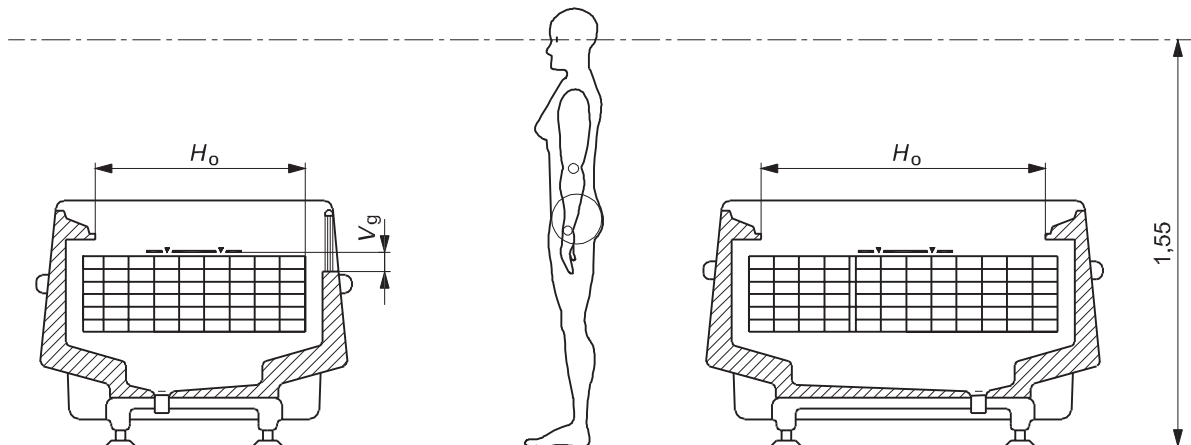

$L_{oh} = 2,500$	$H_o = 0,800$	$L_{oh} = 2,500$	$H_o = 1,084$
$L_{gh} = 2,500$	$H_g = 0$	$L_{gh} = 2,500$	$H_g = 0$
$L_{ov} = 2,500$	$V_o = 0$	$L_{ov} = 2,500$	$V_o = 0$
$L_{gv} = 2,400$	$V_g = 0,058$	$L_{gv} = 2,500$	$V_g = 0$
$TDA = (H_o \times L_{oh}) + (H_g \times L_{gh}) + (V_o \times L_{ov}) + (V_g \times L_{gv})$		$TDA = (H_o \times L_{oh}) + (H_g \times L_{gh}) + (V_o \times L_{ov}) + (V_g \times L_{gv})$	
2,139		2,710	

Figure A.6 — Horizontal, open, island cabinets

Dimensions in metres

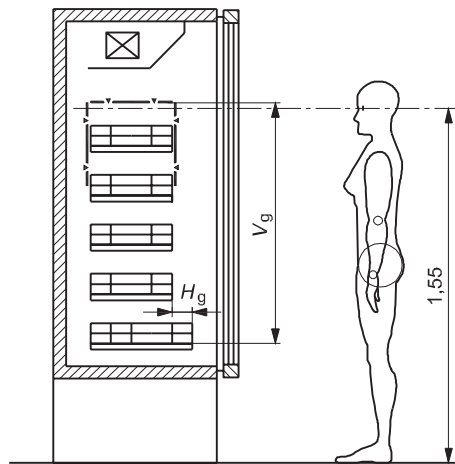

$L_{oh} = 2,500$	$H_o = 0$	
$L_{gh} = 2,500$	$H_g = 0,25$	
$L_{ov} = 2,500$	$V_o = 0$	
$L_{gv} = 2,250$	$V_g = 1,053$	
$TDA = (H_o \times L_{oh}) + (H_g \times L_{gh}) + (V_o \times L_{ov}) + (V_g \times L_{gv})$		2,994

Figure A.7 — Vertical, glass door, cabinet

Dimensions in metres

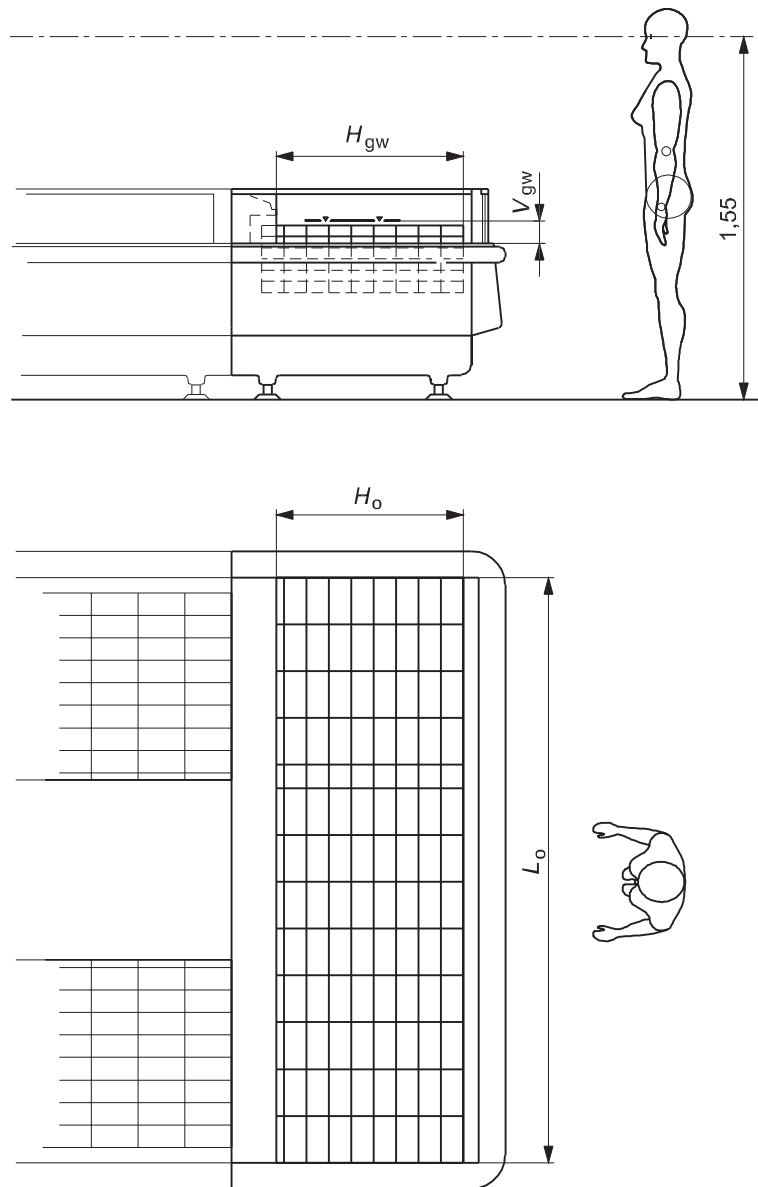

$L_{oh} = 2,500$	$H_o = 0,800$
$L_{gh} = 2,500$	$H_g = 0$
$L_{ov} = 2,500$	$V_o = 0$
$L_{gv} = 2,400$	$V_g = 0,058$
$V_{gw} = 0,058$	$H_{gw} = 0,800$
$TDA = (H_o \times L_{oh}) + (H_g \times L_{gh}) + (V_o \times L_{ov}) + (V_g \times L_{gv}) + (2 \times V_{gw} \times H_{gw})$	
2,232	

Figure A.8 — Horizontal, open, island end cabinet

Dimensions in metres

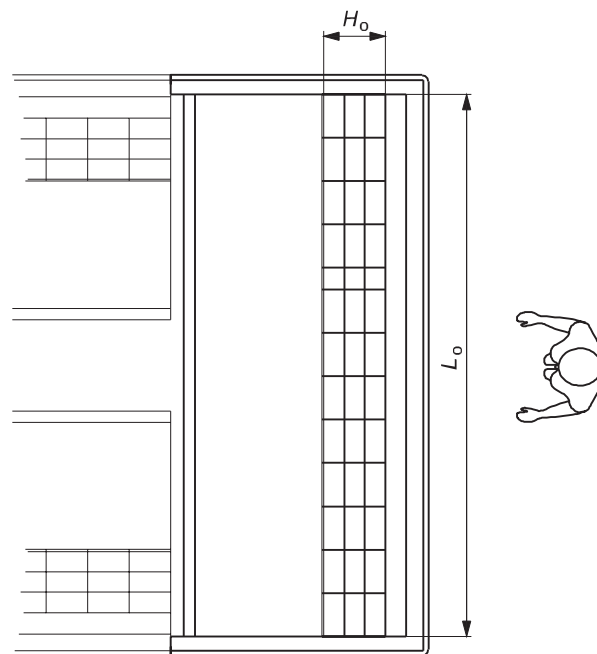
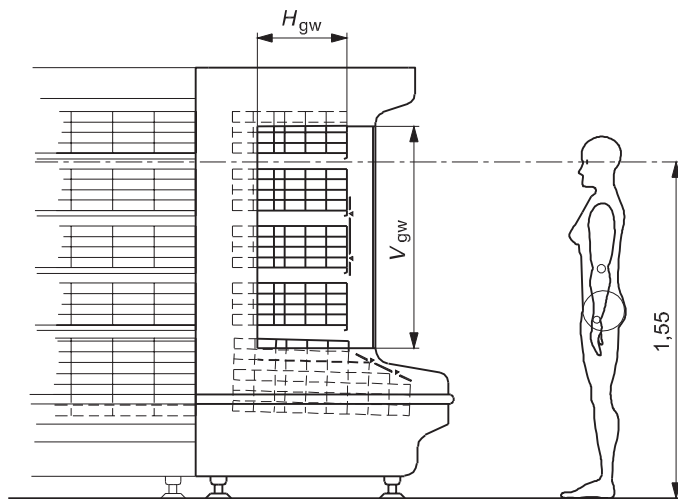

$L_{oh} = 2,500$	$H_o = 0,291$
$L_{gh} = 2,500$	$H_g = 0$
$L_{ov} = 2,500$	$V_o = 1,367$
$L_{gv} = 2,500$	$V_g = 0$
$V_{gw} = 1,022$	$H_{gw} = 0,415$
$TDA = (H_o \times L_{oh}) + (H_g \times L_{gh}) + (V_o \times L_{ov}) + (V_g \times L_{gv}) + (2 \times V_{gw} \times H_{gw})$	
4,993	

Figure A.9 — Vertical, multi-deck end cabinet

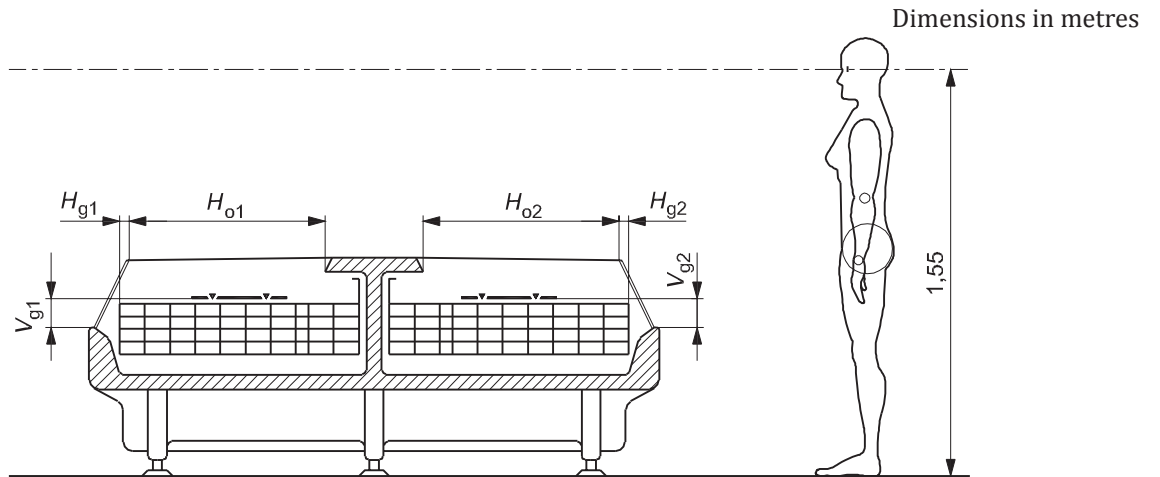

$L_{oh1} = 2,500$	$H_{o1} = 0,770$	
$L_{oh2} = 2,500$	$H_{o2} = 0,770$	
$L_{gh1} = 2,400$	$H_{g1} = 0,012$	
$L_{gh2} = 2,400$	$H_{g2} = 0,012$	
$L_{gv1} = 2,400$	$V_{g1} = 0,090$	
$L_{gv2} = 2,400$	$V_{g2} = 0,090$	
$TDA = (H_{o1} \times L_{oh1}) + (H_{o2} \times L_{oh2}) + (H_{g1} \times L_{gh1}) + (H_{g2} \times L_{gh2}) + (V_{g1} \times L_{gv1}) + (V_{g2} \times L_{gv2})$		4,340

Figure A.10 — Island with air discharge in the middle

Annex B (informative)

Comparison between laboratory and in-store conditions

The complete range of various climate conditions and various ways of loading in stores cannot be simulated in the laboratory. For these reasons, specific climate classes and loading are defined for tests in the laboratory to classify cabinets and to make comparisons.		
For open refrigerated display cabinets, test results in laboratory cannot be directly transposed in stores.		
	Laboratory	In-store
The reference is defined by:	ISO 23953	The law in the country concerned.
	The M-package temperature and the corresponding classes H2, H1, M2, M1, L3, L2, L1.	The temperature of each foodstuff type, affected by its own packaging (dimensions, material, emissivity) and thermal inertia.
	The same standardized loading throughout the test.	A continuous loading variation throughout the day.
The surrounding space is:	The test room climate class and the corresponding stabilized conditions (example: Class 3: 25 °C, 60 % RH).	Some variations of temperature and humidity, notably between day and night or summer and winter.
	A little variation of temperature along the test room height.	A significant stratification of the temperature in the chilled foodstuff zone in the store which is favourable for cabinet running.
	A continuous and horizontal air flow at 0,2 m/s (0; -0,1) which highlights the weak points of the cabinet and so imposes a strong air flow influence.	Some short disruptions made by consumers which creates few disturbances because they are spaced in time and length.
	A defined infrared radiation from the internal lab surfaces.	An undefined infrared radiation from the store surfaces, depending on building insulation, air stratification, lighting type.

The performance evaluation is taken on:	The M-package temperature when the variation is less than 0,5 °C after 24 h in stable conditions.	The foodstuffs temperature in the cabinet; it can depend on the foodstuff temperature at the loading; the most exposed to the infrared radiation, are the first taken by the consumers.
	And the heat extraction rate and the electrical energy consumption measured according to ISO 23953.	The real needs of the store are the figures to calculate the refrigerating system and the yearly energy consumption, taking into account the seasons (summer/winter), the daily cycle (day/night), the store opening periods.

Annex C (informative)

Test for absence of odour and taste

C.1 Preparation and testing

C.1.1 Ambient temperature

The ambient temperature shall be between +16 °C and +30 °C.

C.1.2 Cleaning

The cabinet shall be cleaned prior to the test in accordance with the manufacturer's instructions and afterwards with pure water.

C.1.3 Thermostat setting

The cabinet shall be operated for 48 h, with the thermostat and other control devices set in accordance with the manufacturer's instructions which give the required temperature according to the relevant classification (see [4.2.2](#)).

C.1.4 Samples

The analytical samples and check samples respectively for each cabinet or compartment are:

- 100 ml potable water;
- a slice of fresh unsalted butter of 75 mm × 35 mm × 5 mm.

From each of the above, six samples at least are necessary to serve as analytical samples and six at least to serve as check samples.

The analytical samples shall be placed in Petri dishes and the check samples in glass containers, the latter being hermetically sealed.

Prior to the test, all Petri dishes and containers which are used for the test shall be cleaned with fuming nitric acid and subsequently washed with distilled water until a complete absence of odour is obtained.

The analytical samples of water and butter shall be placed uncovered into the cabinet or compartment. The check samples in the hermetically sealed glass containers shall be placed close to the analytical samples.

C.1.5 Test period

The analytical samples and the check samples shall be left in the operating cabinet with the door(s), if any, closed and at the specified temperature conditions for 48 h. After 48 h, the analytical samples shall be covered.

The analytical samples and check samples shall be removed and warmed to approximately 20 °C.

C.2 Examination of samples

C.2.1 Conditions

Examination shall be made about 2 h after removal of the samples from the cabinet and shall be carried out by at least three examiners familiar with the test method.

Each examiner shall receive

- two analytical samples of water,
- two check samples of water,
- two analytical samples of butter, and
- two check samples of butter.

The identity of the samples shall not be made known to the examiners.

The samples of water shall be examined prior to the samples of butter, unless a separate examination by different examiners takes place.

The examiners shall record their remarks independently of each other, in writing.

C.2.2 Evaluation

The evaluation of the analytical samples shall be carried out with reference to the following scale.

- Mark 0: no foreign odour or foreign taste
- Mark 1: slight foreign odour or foreign taste
- Mark 2: definitely perceptible foreign odour or foreign taste
- Mark 3: distinct foreign odour or foreign taste

When the mean value of the individual results during each evaluation for odour and taste exceed Mark 1, the test shall be repeated. The following provisions shall be made for this second test:

- defrosting of the evaporator;
- cleaning of the cabinet or compartments;
- operation of the empty cabinet for one week;
- repetition of defrosting of the evaporator;
- temperature adjustment for the second test for absence of odour and taste.

Annex D (normative)

Performance and energy rating of commercial refrigerated display cabinets

D.1 Scope

This Annex is intended for establish data requirements to Standard Ratings of Refrigerated Display Cabinets with remote or incorporated condensing units. It is intended for the guidance of the industry, including manufacturers, engineers, installers, contractors and users. The values reported using this Annex allow comparison of Specific Energy Consumption (SEC) of different models of Commercial Refrigerated Display Cabinets within the same product family, at the same product temperature classification, at Standard Rating Conditions. Furthermore, using this Annex it is possible to compare the specific energy consumption of the same cabinet model when alternative electric components are used.

The following definitions shall be used:

a) **Product family**

Group of cabinets in accordance with ISO 23953-1:2015, Annex A (see [Table 1](#) below).

b) **Product Temperature**

One of the classifications defined in [4.2.2](#), Table of this part of ISO 23953. The Product Temperature establish the performance level of the Refrigerated Display Cabinet.

c) **Anti-condensate Energy Consumption (AEC)**

The Total Daily Energy Consumption used in condensate removal on the outside of the Commercial Refrigerated Display Cabinet, which typically includes condensate heater energy expressed in kW•h per day.

d) **Defrost Energy Consumption (DFEC)**

The energy consumed by defrost heaters during defrost period expressed in kW•h per day.

e) **Fan Energy Consumption (FEC)**

The energy consumed by fan motors expressed in kW•h per day.

f) **Lighting Energy Consumption (LEC)**

The energy consumed by lights fitted in the refrigerated display cabinet expressed in kW•h per day.

g) **Condensate Evaporator Pan Energy Consumption (PEC)**

The amount of heat energy required to change condensate from liquid to a vapor in the pan of an automatic water evacuation system of a cabinet with an incorporated condensing unit and expressed in kW•h per day.

h) **Compressor Energy Consumption (CEC)**

The energy consumed by the compressor of a condensing unit incorporated in a refrigerated display cabinet and expressed in kW•h per day.

i) **Total Revised Daily Electrical Energy Consumption (TECR)**

The sum of the Revised Refrigeration Daily Electrical Energy Consumption (RECR) with the recalculated value of Direct Daily Electrical Energy Consumption (DECR) when alternate electric components are used in a cabinet intended for a remote compression type or indirect type refrigerating system and expressed in kW•h per day.

j) Revised Refrigeration Energy Consumption (RECR)

The sum of the Refrigeration Daily Electrical Energy Consumption (REC) and the additional Refrigeration Daily Electrical Energy Consumption (RECA) for each alternate electric component(s) for a cabinet intended for a remote compression type or indirect type refrigerating system and expressed in kW•h per day.

k) Additional Refrigeration Daily Electrical Energy Consumption (RECA)

The additional indirect effect of alternate electric component(s) on the Refrigeration Daily Electrical Energy Consumption for a cabinet intended for a remote compression type or indirect type refrigerating system and expressed in kW•h per day.

l) Published Standard Rating

A statement of the assigned values of those performance characteristics, under stated Standard Rating Conditions, by which a unit may be chosen for its application. The term Published Standard Rating includes the rating of all performance characteristics shown on the unit or published in specifications, advertising or other literature controlled by the manufacturer, at stated Standard Rating.

m) Standard Rating

A rating based on tests performed at Standard Rating Conditions.

n) Rating Conditions

Any set of operating conditions under which a single level of performance results and which causes only that level of performance to occur.

o) Standard Rating Conditions

Rating Conditions used as the basis of comparison for performance characteristics.

p) Incorporated compressor Coefficient of Performance (COP_{ic})

The ratio between the cooling capacity in watts and the electric power input values in watts at any given set of Rating Conditions for an incorporated compressor expressed in W/W.

Table D.1 — Designation of refrigerated display cabinet families (Informative Annex A of ISO 23953-1)

Application	Temperature positive		Temperature negative	
To be used for	Chilled foodstuffs		Frozen, quick frozen foodstuffs, and ice cream	
Horizontal	Chilled, serve-over counter open service access	HC1	Frozen, serve-over counter open service access	HF1
	Chilled, serve-over counter with integrated storage open service access	HC2		
	Chilled, open, wall site	HC3	Frozen, open, wall site	HF3
	Chilled, open, island	HC4	Frozen, open, island	HF4
	Chilled, glass lid, wall site	HC5	Frozen, glass lid, wall site	HF5
	Chilled, glass lid, island	HC6	Frozen, glass lid, island	HF6
	Chilled, serve-over counter closed service access	HC7	Frozen, serve-over counter closed service access	HF7
	Chilled, serve-over counter with integrated storage closed service access	HC8		
Vertical	Chilled, semi-vertical	VC1	Frozen, semi-vertical	VF1
	Chilled, multi-deck	VC2	Frozen, multi-deck	VF2
	Chilled, roll-in	VC3		
	Chilled, glass door	VC4	Frozen, glass door	VF4
Combined	Chilled, open top, open bottom	YC1	Frozen, open top, open bottom	YF1
	Chilled, open top, glass lid bottom	YC2	Frozen, open top, glass lid bottom	YF2
	Chilled, glass door top, open bottom	YC3	Frozen, glass door top, open bottom	YF3
	Chilled, glass door top, glass lid bottom	YC4	Frozen, glass door top, glass lid bottom	YF4
	Multi-temperature, open top, open bottom			YM5
	Multi-temperature, open top, glass lid bottom			YM6
	Multi-temperature, glass door top, open bottom			YM7
	Multi-temperature, glass door top, glass lid bottom			YM8
R Remote condensing unit	V Vertical			
I Incorporated condensing unit	Y Combined			
A Assisted service	C Chilled			
S Self-service	F Frozen			
H Horizontal	M Multi-temperature			
General classification can be used as follows: HC1, VF1, YM5. When necessary, the classification can be more precise, for example, RHC1A, IVF1S.				
NOTE Serve-over counters are primarily in assisted service but can be in self-service. Chilled multi-deck cabinets are primarily in self-service but can be in assisted service.				

D.2 Standard Rating Conditions for Refrigerated Display Cabinets

Standard Rating Conditions are defined as follow:

- a) Test: in compliance with this part of ISO 23953;
- b) Climate Class: Climate Class 3: Dry bulb temperature 25 °C; Relative Humidity. 60 %;
- c) Supply Voltage and Frequency: that is reported in the cabinet name plate.

NOTE If cabinet is not designed for climate class 3, rating conditions should be explicitly stated.

D.3 Standard Rating Requirements for Remote Refrigerated Display Cabinets

D.3.1 General

This section identifies the necessary data required to calculate the Specific Daily Electrical Energy Consumption values (SEC) at Standard Rating Conditions for Remote Commercial Refrigerated Display Cabinets from measured data or from calculated data when, alternate electrical components are applied.

The SEC value is expressed by the Formula (D.1):

$$SEC = TEC/TDA \text{ [kWh/24h*m}^2\text{]} \quad (D.1)$$

The TDA value is calculated for each cabinet model following indication of [Annex B](#) of this Standard.

The TEC value is given by the sum of the Total Direct Daily Electrical Energy consumption (DEC) with the Total Refrigeration Daily Electrical Energy Consumption (REC) and expressed by the Formula (D.2):

$$TEC = DEC + REC \text{ [kWh/24h]} \quad (D.2)$$

D.3.2 Evaluation of DEC

For cabinets with a remote condensing unit the DEC does not include the REC.

For each cabinet, the DEC value shall be measured, with all fitted electrical power-using components switched on.

The DEC recorded for each test shall be the summation of all electrical energy consumed by the refrigerated cabinet during the test period and shall be expressed by the Formula (D.3):

$$DEC = FEC + LEC + AEC + DFEC + PEC + CPEC \text{ [kWh/24h]} \quad (D.3)$$

NOTE 1 The value of CPEC shall be defined only for cabinets intended for an indirect type refrigerating system.

NOTE 2 If, for technical reasons, it is too difficult to measure separately the component powers, it is possible to use the DEC directly measured or the power consumed by any group of single components.

D.3.2.1 Evaluation of FEC

The FEC shall be measured data for all fan motors or calculated data using the motor efficiency:

$$FEC = (Pf \cdot tf)/(1000) \quad (D.4)$$

where

$$Pf = (Pfi \cdot n) \quad (\text{measured}) \text{ or}$$

$$Pf = (Pfo \cdot n)/hm \quad (\text{calculated})$$

with:

Pf = Power of all fans, W

tf = Time fans are on in 24 h period, h

n = Number of fan motors

P_{fi} = Input power of single fan, W

P_{fo} = Power fan output found on part nameplate, W

hm = Motor efficiency

D.3.2.2 Evaluation of LEC

The LEC shall be measured data for all lights or calculated data, using the following Formula (D.5):

$$LEC = (P_{li} \cdot t_l) / (1000) \quad (D.5)$$

with:

P_{li} = Power light input, W

t_l = Time lights are on in 24 h period, h

D.3.2.3 Evaluation of AEC

The AEC shall be measured data for all anti condensate heaters or calculated data, using the following Formula (D.6):

$$AEC = (P_{ai} \cdot t_a) / (1000) \quad (D.6)$$

with:

P_{ai} = Power anti-condensate heater input, W

t_a = Time anti-condensate heaters are on in 24 h period, h

D.3.2.4 Evaluation of DFEC

The DFEC shall be measured data for all defrost heaters or calculated data, using the following Formula (D.7):

$$DFEC = (P_d \cdot t_d) / (1000) \quad (D.7)$$

with:

P_d = Power defrost heater input, W

t_d = Time defrost heaters are on in 24 h period, h

D.3.2.5 Evaluation of PEC

The PEC shall be measured data for all pan heaters or calculated data, using the following Formula (D.8):

$$PEC = (P_c \cdot t_c) / 1000 \quad (D.8)$$

with:

P_c = Power condensate evaporator pan heaters input, W

t_c = Time condensate evaporator pan heaters are on in 24 h period, h

D.3.2.6 Evaluation of CPEC

For the pumping electrical energy consumption CPEC calculation see [5.3.6.3.3](#).

D.3.2.7 Other Electric Energy Consumption

If there are additional options that decrease or increase the electrical units, they shall be noted under "Other Loads" with an appropriate calculation for energy consumption expressed in kW•h per day.

D.3.3 Evaluation of REC

The refrigeration electrical energy consumption for a cabinet intended for a remote compression-type or indirect type refrigerating system, REC, is calculated as specify at [Clause 5.3.6.3.3](#) of this part of ISO 23953.

D.3.4 Electric energy consumption calculation when alternate components are used

D.3.4.1 Alternate Components - Effect on DEC

When removing or substituting an electric component the energy consumption of substituted or alternate components shall be measured or can be calculated using Formulae (D.4), (D.5), (D.6), (D.7) (D.8) and the component's nameplate rating. In this case, the energy usage of the substituted or alternate components shall be used to recalculate the DEC using the Formula (D.3) and changing the value (FEC, LEC, AEC DFEC, PEC or CPEC) corresponding to measurement/calculation of the specific component substituted.

When calculating the fan motor energy (FEC) for substituting a fan motor, the airflow rate produced from the assembly shall be equal to the original configuration.

When calculating the pump motor energy (CPEC) for substituting a pump, the flow rate and pressure drop produced from the assembly shall be equal to the original configuration.

D.3.4.2 Alternate Components - Effect on REC

The Revised Refrigeration Energy Consumption (RECR) for a cabinet intended for both a remote compression type both indirect type refrigerating system when alternate component(s) are used, shall be measured or calculated, only when the substituted component is fitted within the refrigerated space, as the sum of the REC and the Additional Refrigeration Energy Consumption (RECA) for each component:

$$RECR = REC + \sum RECA \quad (D.9)$$

where the value of each Additional Refrigeration Energy Consumption RECA is given by the Formula (D.10):

$$RECA = \left[(P_s \times t_s - P_o \times t_o) \right] \times \frac{(T_c - T_{mrun})}{0,34 \times T_{mrun}} \quad (D.10)$$

with:

P_s = Power input calculated for substitution part, fitted within the refrigerated space (W)

P_o = Power input calculated for original part, (W)

t_s = Time substitution part is on, in 24 h period, (h)

t_o = Time original part is on, in 24 h period, (h)

D.3.4.3 Alternate Components - Effect on TEC

The Total Revised Refrigeration Energy Consumption (TECR) for a cabinet intended for both a remote compression type both indirect type refrigerating system when alternate component(s) are used, is the sum of the RECR and the recalculated value of Direct Electrical Energy Consumption (DECR) as specify in [D.3.4.1](#):

$$TECR = RECR + DEC \quad (D.11)$$

D.4 Standard Rating Requirements for Commercial Refrigerated Display Cabinets with incorporated condensing unit

D.4.1 General

This section identifies the necessary data required to calculate the Specific Daily Electrical Energy Consumption (SEC) at Standard Rating Conditions for Commercial Refrigerated Display Cabinets with incorporated condensing unit, from measured data or from calculated data when, alternate electrical components are applied.

The SEC value is expressed by the Formula (D.12):

$$SEC = TEC/TDA \text{ [kWh/24h*m}^2\text{]} \quad (D.12)$$

The TDA value is calculated for each cabinet model following indication of [Annex B](#) of this Standard.

For cabinets with an incorporated condensing unit, the Direct Daily Electrical Energy Consumption (DEC) equals the total daily electrical energy consumption (TEC), as it includes the compressor energy consumption. Refrigeration daily electrical energy consumption (REC) is not defined for these cabinets.

As a consequence, the DEC is expressed by:

$$TEC = DEC \text{ [kWh/24h]} \quad (D.13)$$

D.4.2 Evaluation of TEC

The TEC recorded for each test shall be the summation of all electrical energy using components given in the Formula (D.14):

$$TEC = DEC = FEC + LEC + AEC + DFEC + PEC + CEC \quad (D.14)$$

Measure the TEC, including the compressor energy consumption, reported in kilowatt hours per 24-h period, the compressor switching on/off frequency and the relative running time (ratio of running time to overall duration of a measurement cycle excluding defrost time), with all fitted electrical power-using components switched on and including the energy consumption due to an automatic defrost water removal.

NOTE If, for technical reasons, it is too difficult to measure separately the component powers, it is possible to use the TEC directly measured or the power consumed by any group of single components.

The values of FEC, LEC, AEC, DFEC and PEC can be evaluated using respectively the Formulae (D.4), (D.5), (D.6), (D.7) and (D.8).

D.4.3 Evaluation of CEC

The CEC shall always be measured data following Formula (D.15):

$$CEC = \left(P_{cpr} \cdot t_{cpr} \right) / 1000 \quad (D.15)$$

where

P_{cpr} power compressor input, W (average value measured during compressor running time);

t_{cpr} time compressors are on in 24 h period, h.

D.4.4 Electric energy consumption calculation when alternate components are used in Commercial Refrigerated cabinets with incorporated condensing unit

The direct energy consumption of alternate components shall be measured or calculated from the component's nameplate rating. A calculated change in the energy usage for the alternate component can be substituted, for the energy usage of the component used in the total energy test.

The revised direct electrical energy consumption with alternate components RDEC is the summation of the direct electrical energy consumption to the effect on heat extraction rate which is part of the direct electrical energy consumption of the compressor of each energy using component, expressed in Formula (D.16):

$$DECR = DEC + (FECR + LECR + AECR + DFECR + PECR) \quad (D.16)$$

Where DEC value is expressed in Formula (D.10) and values from alternate components FECR, LECR, AECR, DFECR and PECR can be calculated by the following formulae:

$$FECR = \left(Pf \cdot tf \cdot COP_{ic} \right) / 1000 \text{ [kWh/24h]} \quad (D.17)$$

$$LECR = \left(Pli \cdot tli \cdot COP_{ic} \right) / 1000 \text{ [kWh/24h]} \quad (D.18)$$

$$AECR = \left(Pai \cdot ta \cdot COP_{ic} \right) / 1000 \text{ [kWh/24h]} \quad (D.19)$$

$$DFECR = \left(Pd \cdot td \cdot COP_{ic} \right) / 1000 \text{ [kWh/24h]} \quad (D.20)$$

$$PECR = \left(Pc \cdot tc \cdot COP_{ic} \right) / 1000 \text{ [kWh/24h]} \quad (D.21)$$

And the Coefficient of Performance of the incorporated compressor is given by Formula (D.22):

$$COP_{ic} = 3,08 \cdot e^{(35-0,024 \cdot \theta_{mrun}) / t_c} \quad (D.22)$$

where

t_c arithmetic average of condenser-saturated temperature obtained from condensing pressure by referring to table of saturation properties for refrigerant in use, during t_{run} , °C.

Typical COP values for reciprocating compressors used in cabinets with incorporated condensing units at a reference operating condition of $\theta_{mrun} = -10$ °C (chilled), $\theta_{mrun} = -35$ (frozen). $t_c = 35$ °C are:

$COP_{ic} = 1,3$ for frozen cabinets

$COP_{ic} = 2,3$ for chilled cabinets

NOTE These COP values, typical for reciprocating compressors can be used when direct measurement of θ_{mrun} is difficult due to hermetic refrigeration circuit without service valves to connect pressure transducer.

Bibliography

- [1] EN 378-1, *Refrigerating systems and heat pumps — Safety and environmental requirements — Part 1: Basic requirements, definitions, classification and selection criteria*
- [2] EN 614-1, *Safety of machinery — Ergonomic design principles — Part 1: Terminology and general principles*
- [3] EN 12830, *Temperature recorders for the transport, storage and distribution of chilled, frozen, deep-frozen/quick-frozen food and ice cream — Tests, performance, suitability*

NATIONAL ANNEX E

(National Foreword)

LISTS OF TECHNICAL DEVIATIONS

E-1 The text of the International Standard ISO 23953-2 : 2015 has been approved for publication as Indian Standard with agreed modifications as indicated below.

<i>Sl No.</i>	<i>Clause/Sub-clause</i>	<i>Modification</i>
i)	1	<p>Add the following to the existing clause at the end:</p> <p>'Following are excluded from the scope of this standard:</p> <ul style="list-style-type: none"> a) Products falling under IS 7872; b) Combined appliance (freezer plus cooler); c) Appliances which are designed for medical applications; and d) Appliances other than mains operated appliances. <p>NOTE — The appliances covered under this standard are not intended for cooling down (pull-down) but are intended for maintaining the intended product temperature.'</p>
ii)	2	<p>Add the following to the list of references:</p> <p>'IS 7872 : 2020 Deep freezers — Specification (<i>second revision</i>)'.</p>
iii)	4.1.1.1, a)	<p>Add the following to the existing at the end:</p> <p>'Compliance shall be checked by the test as per 21.102 of IS/IEC 60335-2-89.'</p>
iv)	4.1.1.3, para 2	<p>Substitute the following for the existing:</p> <p>'Any condensate or defrost water receptacle, or group of receptacles, requiring to be emptied manually shall have a capacity equivalent to at least 48 h of normal operation as defined in 3.1.9 of IS/IEC 60335-2-89) in the appropriate climate class for which the cabinet is intended.'</p>
v)	4.1.1.4	<p>Add the following at the end of last para:</p> <p>'The transparent doors and lids should be subjected to water vapor condensation test as per 4.2.4 and 5.3.4. The acceptance criteria are condensation code 'F' or better as defined in 5.3.4.'</p>
vi)	4.2.6	<p>Add the following new sub-clause after 4.2.6:</p> <p>'4.3 Safety requirements shall be met through compliance of IS/IEC 60335-2-89.'</p>
vii)	5.2.2	<p>Add the following new sub-clause to the existing at the end:</p> <p>5.2.3 Net Volume</p> <p>The net volume (V_n) shall be calculated as the sum of the individual volumes which is obtained as follows.</p> <ul style="list-style-type: none"> a) For shelves: by multiplying each refrigerated shelf area by the distance from the top of the shelf up to 10 mm from the next shelf top surface. For the top shelf the volume shall be obtained multiplying the refrigerated shelf area by the distance up to the load limit. b) For horizontal cabinets: by multiplying each bottom basket area by the distance from internal bottom of the basket up to 10 mm

from the next top surface. For the top basket the volume shall be obtained multiplying the bottom basket area by the distance up to the load limit.

- c) For horizontal cabinets without baskets: by multiplying internal floor area by the distance from internal floor up to load line. Each individual volume above a shelf is the vertical projection of the refrigerated shelf area.

Each of the individual volumes shall be expressed in litres, to one decimal place. The net volume shall be rounded to one decimal place.

The net volume shall be calculated by summing-up all individual volumes.

The volume of constructional shelf support protuberances shall be excluded from the volume calculation (see Figure 1). Compartment(s) of a combined refrigerated cabinet that are not foreseen for storage are not subjected to calculation of net volume:

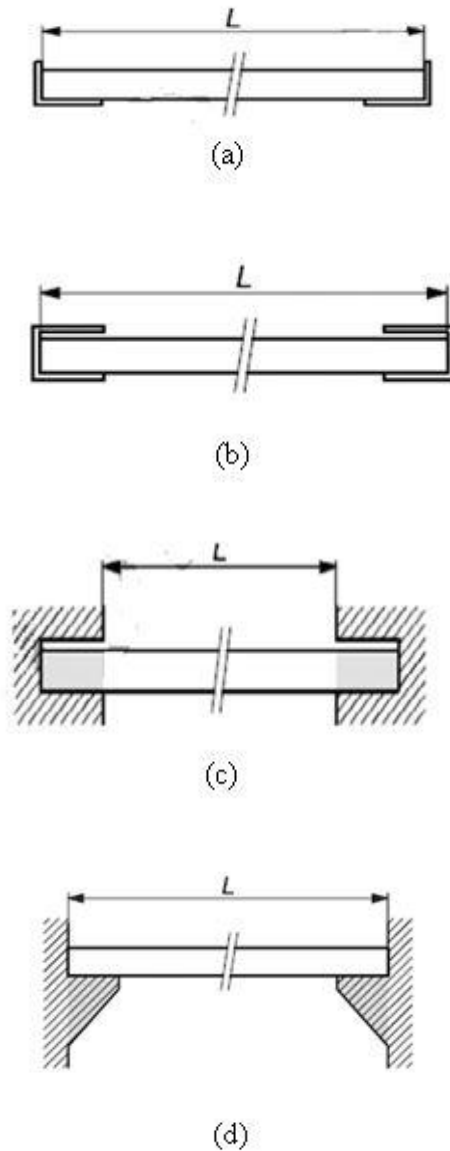

Fig. 1'

viii)	5.3.1.1 , para 1, first sentence	Substitute the following for the existing: 'The test room shall be a parallelepiped space in which two of the opposite side walls, referred to as the discharge technical side wall and the return technical side wall, are designed to create an even, horizontal or vertical air flow within the test room.'
ix)	5.3.1.1 , last para	Substitute the following for the existing: 'The walls, ceilings and any partitions of rooms intended for the testing of refrigerated display cabinets shall be so painted that the emissivity is between 0.9 and 1 at 25 °C.'
x)	5.3.1.2 , para 4	Substitute the following for the existing: 'The mean horizontal or vertical air velocity measured during 1 min with a maximal interval of 5 s at each of the points defined above shall not exceed beyond 0.25 m/s.'
xi)	6.3.6	Add the following new clauses after 6.3.6 : 6.4 Type Test The tests specified below shall constitute the type tests and shall be carried out on a sample selected preferably at random from regular production or from the finished stock. Before commencement of the tests, the sample shall be visually examined and inspected of components, parts and their assembly, constructions, mechanical hazards, marking provision of suitable terminals for supply connections, earthing, and the screws effectiveness and connection. The external surface finish shall be even and free from finishing defects. The following tests shall constitute the type tests: <ul style="list-style-type: none"> a) Seal test of doors and lids (see 6.2.1); b) Linear dimensions, areas and volumes (see 6.2.2); c) Test for absence of odour and taste (see 6.2.3); d) Temperature test (see 6.3.3); e) Water vapour condensation test (see 6.3.4); f) Electrical energy consumption test (see 6.3.5); and g) Heat extraction rate measurement when the condensing unit is remote from the cabinet (see 6.3.6). 6.5 Routine Test Each unit shall be subjected to the routine tests at the manufacturer's works. The following shall constitute as a routine test as per IS 302-1 : <ul style="list-style-type: none"> a) Earth continuity test (see A-1); and b) Electric strength (see A-2).'
xii)	7.2, (c)	Delete the existing and renumber the subsequent SI No.
xiii)	7.2	Add the following to the existing at the end: 'f) Country of manufacture.'
xiv)	7.3, (c), (12)	Add the following to the existing at the end:

		'13) A description of the cabinet's internal fittings (if any).'
xv)	7.3	<p>Add the following new clause after 7.3:</p> <p>'7.4 BIS Certification Marking</p> <p>The product conforming to the requirements of this standard may be certified as per the conformity assessment schemes under the provisions of the <i>Bureau of Indian Standards Act, 2016</i> and the Rules and Regulations framed thereunder, and the product may be marked with the Standard Mark.'</p>

[\(Continued from second cover\)](#)

<i>International Standard</i>	<i>Corresponding Indian Standard</i>	<i>Degree of Equivalence</i>
IEC 60335-2-89 Household and similar electrical appliances — Safety — Part 2-89: Particular requirements for commercial refrigerating appliances with an incorporated or remote refrigerant unit or compressor	IS/IEC 60335-2-89 : 2010 Household and similar electrical appliances — Safety: Part 2-89 Particular requirements for commercial refrigerating appliances with an incorporated or remote refrigerant unit or compressor	Identical

This standard also makes a reference of technical deviation (modifications) to the ISO standard. The deviations are given in [National Annex E](#).

While formulating this [National Annex E](#), the following standard has also been reviewed:

ANSI AHAM HRF-1 : 2004 Energy, performance and capacity of household refrigerators, refrigerator-freezers and freezers.

For the purpose of deciding whether a particular requirement of this standard is complied with, the final value, observed or calculated, expressing the result of a test or analysis, shall be rounded off in accordance with IS 2 : 2022 'Rules for rounding off numerical values (*second revision*)'. The number of significant places retained in the rounded off value should be the same as that of the specified value in this standard.

Bureau of Indian Standards

BIS is a statutory institution established under the *Bureau of Indian Standards Act, 2016* to promote harmonious development of the activities of standardization, marking and quality certification of goods and attending to connected matters in the country.

Copyright

BIS has the copyright of all its publications. No part of these publications may be reproduced in any form without the prior permission in writing of BIS. This does not preclude the free use, in the course of implementing the standard, of necessary details, such as symbols and sizes, type or grade designations. Enquiries relating to copyright be addressed to the Head (Publication & Sales), BIS.

Review of Indian Standards

Amendments are issued to standards as the need arises on the basis of comments. Standards are also reviewed periodically; a standard along with amendments is reaffirmed when such review indicates that no changes are needed; if the review indicates that changes are needed, it is taken up for revision. Users of Indian Standards should ascertain that they are in possession of the latest amendments or edition by referring to the website-www.bis.gov.in or www.standardsbis.in.

This Indian Standard has been developed from Doc No.: MED 03 (19252).

Amendments Issued Since Publication

Amend No.	Date of Issue	Text Affected

BUREAU OF INDIAN STANDARDS

Headquarters:

Manak Bhavan, 9 Bahadur Shah Zafar Marg, New Delhi 110002

Telephones: 2323 0131, 2323 3375, 2323 9402

Website: www.bis.gov.in

Regional Offices:

Central : 601/A, Konnectus Tower -1, 6th Floor,
DMRC Building, Bhavbhuti Marg, New
Delhi 110002

Telephones

{ 2323 7617

Eastern : 8th Floor, Plot No 7/7 & 7/8, CP Block, Sector V,
Salt Lake, Kolkata, West Bengal 700091

{ 2367 0012
2320 9474

Northern : Plot No. 4-A, Sector 27-B, Madhya Marg,
Chandigarh 160019

{ 265 9930

Southern : C.I.T. Campus, IV Cross Road, Taramani, Chennai 600113

{ 2254 1442
2254 1216

Western : 5th Floor/MTNL CETTM, Technology Street, Hiranandani Gardens, Powai,
Mumbai 400076

{ 2570 0030
2570 2715

Branches : AHMEDABAD, BENGALURU, BHOPAL, BHUBANESHWAR, CHANDIGARH, CHENNAI, COIMBATORE, DEHRADUN, DELHI, FARIDABAD, GHAZIABAD, GUWAHATI, HARYANA (CHANDIGARH), HUBLI, HYDERABAD, JAIPUR, JAMMU, JAMSHEDPUR, KOCHI, KOLKATA, LUCKNOW, MADURAI, MUMBAI, NAGPUR, NOIDA, PARWANOO, PATNA, PUNE, RAIPUR, RAJKOT, SURAT, VIJAYAWADA.