

Correction  
done on Portal

वाष्प दाब पर प्रचालित पोर्टेबल  
द्रवित पेट्रोलियम गैस साधित्र —  
विशिष्टि  
(पहला पुनरीक्षण)

Portable Liquefied Petroleum Gas  
Appliances Operating at Vapour  
Pressure — Specification  
( First Revision )

ICS 75.160.30; 97.040.20

© BIS 2024



भारतीय मानक ब्यूरो  
BUREAU OF INDIAN STANDARDS  
मानक भवन, 9 बहादुर शाह ज़फर मार्ग, नई दिल्ली - 110002  
MANAK BHAVAN, 9 BAHADUR SHAH ZAFAR MARG  
NEW DELHI - 110002  
[www.bis.gov.in](http://www.bis.gov.in) [www.standardsbis.in](http://www.standardsbis.in)

## FOREWORD

This Indian Standard (First Revision) was adopted by the Bureau of Indian Standards, after the draft finalized by the Domestic and Commercial Gas Burning Appliances (Pressure Type) Sectional Committee had been approved by the Mechanical Engineering Divisional Council.

This standard was first published in 1985. This standard is being revised to incorporate the following changes:

- a) Scope of the standard has been modified to specify that various types of appliances which are covered in the standard are to be used with ISI marked cartridges up to 500 ml or gas cylinders up to 13 litre water capacity. Scope has been further elaborated to indicate inclusions and exclusions;
- b) Reference standards have been updated;
- c) Appliances have been classified according to the gases likely to be used with;
- d) Requirements of materials of valve body, washers, O-seals and jointing compounds have been specified;
- e) Requirements of strength and stability test has been introduced. Also, requirements and test methods of earlier existing stability test ([5.5.2](#) and [6.5.2](#)) have been changed;
- f) Requirements and test method of soundness test has been changed;
- g) Requirements of connections for different types of appliances (connected to the gas container by a flexible hose, Intended to be directly fitted to the gas cartridge or gas cylinder, connected to refillable gas cylinder with self-closing valves of threaded and clip-on outlets) has been changed;
- h) Requirements of transport, fixing and mobility devices has been introduced;
- j) Requirements of taps and needle valves has been introduced;
- k) Requirements of control handles has been introduced;
- m) Requirements for injector has been changed;
- n) Requirements for ignition devices has been introduced;
- p) Flame supervision devices and their requirements has been introduced;
- q) Burners and radiant elements and their requirements has been introduced;
- r) Requirements of grids has been introduced;
- s) Requirements of turnspits has been introduced;
- t) Requirements of fireguards for heating appliances has been introduced;
- u) Requirements of locations and compartments for cartridges or gas cylinders has been introduced;
- v) Variation of heat input has been added as new test;
- w) Resistance to overheating has been added as new test;
- y) Surface temperature requirement has been changed according to types of appliances (floor standing or table standing, appliances designed to be held during use);
- z) Requirements of temperature of panels (floors, walls or ceilings) has been introduced;
- aa) Requirements of ignition and flame stability has been changed. Also requirements of cross lighting has been introduced;
- ab) Test method for resistance to draught has been changed;
- ac) Resistance to liquid spillage has been added as new test;
- ad) Requirements for combustion and its test method has been changed;
- ae) Requirements of accumulation of "Un-Burnt Gas" has been introduced;
- af) Safety at high temperature has been added as new test;
- ag) Requirements for shooting-condensation has been introduced;
- ah) Rational use of energy for stove burners has been added as new test;
- aj) Requirements of durability of marking has been introduced;

*(Continued on third cover)*

*Indian Standard***PORTABLE LIQUEFIED PETROLEUM GAS APPLIANCES  
OPERATING AT VAPOUR PRESSURE — SPECIFICATION***( First Revision )***1 SCOPE**

**1.1** This standard specifies the construction and performance characteristics related to safety and rational use of energy of portable liquefied petroleum gas appliances operating at vapour pressure within the gas cartridge or gas cylinder, excepting those where the gas cartridge is inserted horizontally in the chassis.

NOTE — These appliances are referred to in the body of the text as ‘appliance’.

**1.2** This standard applies to various types of portable liquefied petroleum gas appliances operating at vapour pressure and designed to be used with ISI marked cartridges up to 500 ml or gas cylinders up to 13 litre water capacity.

**1.3** This standard covers appliances for outdoor or in well ventilated areas only. For example, the following types of appliances are covered:

- a) Cooking appliances (stoves, grills, barbecues etc);
- b) Lighting appliances;
- c) Heating appliances:
  - 1) Space heaters, and
  - 2) Gas iron.

This standard only applies to appliances with a maximum heat input of up to 3 kW for outdoor use only [Applicable for item c) 1) and c) 2)].

- d) Blowtorches — This document only applies to blow torches without a flexible hose.
- e) Laboratory burners — The requirements apply to these appliances or their functional sections whether or not the latter are independent or incorporated into an assembly.

Appliances covered by this standard are not connected to a flue for the discharge of products of combustion and are not connected to the mains electricity supply.

This standard covers neither appliance supplied with LPG in the liquid phase nor those incorporating a

fixed gas reservoir which may or may not be refilled by the user.

It does not apply to gas lighters like cigarette lighters, cigar lighters and pipe lighters. This standard does not apply to gas appliances operating with a valve cartridge which is horizontally integrated into the chassis of the appliances also called ‘flat portable gas stove’.

Requirements for rational use of energy have been included for stove burners.

However, such requirements have not been included for the other types of appliances because:

- a) For grills and barbecues, this is a type of cooking which is achieved by various means such as radiant elements, in addition, this type of cooking varies according to the type of food and region where the appliance is used;
- b) For lighting appliances, the consumption is insignificant because these appliances have a very low rate and are used only for a short time;
- c) For heating appliance, all the heat produced is discharged into the environment; and
- d) For tools such as blow torches which are not professional tools in regular use, the gas consumption depends very much on the way it is used.

**2 REFERENCES**

The standards listed in [Annex A](#) contain provisions which through reference in this text, constitute provision of this standard. At the time of publication, the editions indicated were valid. All standards are subject to revision and parties to agreements based on this standard are encouraged to investigate the possibility of applying the most recent edition of these standards:

**3 TERMINOLOGY**

For the purpose of this standard, definitions given in IS 6480 shall apply.

**3.1 Stove** — Cooking appliance incorporating one or several burners and a pan support(s) designed in

such a way that it (they) can support the vessels containing the food.

**3.2 Flat Portable Gas Stove** — Flat stove operating with a gas cartridge horizontally placed in the chassis for which the length or width is bigger than its height.

NOTE — Figure 2 gives example of a flat portable gas stove.

**3.3 Vapour Pressure Appliance** — Appliance for which the pressure at the gas inlet of the appliance is equal to the pressure in the gas cartridge or gas cylinder.

NOTES

1 If the appliance is fixed directly to the gas cylinder by a rigid connection, the appliance inlet is the part of the connection that takes the gas from the cylinder. A pressure reducing device may be incorporated in the gas circuit, between the gas inlet and the injector.

2 If the appliance is connected to the gas container by a flexible hose, the pressure in the flexible hose once it is connected to the gas container is equal to the pressure in the gas container. A pressure reducing device may be incorporated in the gas circuit downstream of the flexible hose.

**3.4 Gas Cylinder** — Refillable or non-refillable container fitted with a valve filled with gas or a gas mixture.

**3.5 Gas Cartridge** — Non-refillable container with a maximum capacity of 500 ml filled with gas or a gas mixture.

NOTE — It may be fitted with a valve. If it is not fitted with a valve, the release of gas is carried out following perforation of the cartridge by means of a device incorporated in the appliance.

**3.6 Cooking Device** — Device supplied with the appliance designed to hold or receive the food to be cooked.

NOTE — Grid, turnspit, baking tray etc.

**3.7 Useful Part of a Cooking Device** — Part of the device in contact with food during cooking.

**3.8 Grid** — Cooking device designed to hold the food to be cooked.

NOTE — Its useful component(s) can be rigid or flexible.

**3.9 Grid with Flexible Useful Components** — Cooking device made up of two joined components enabling tight gripping of the food to be cooked.

NOTE — Each component consists of a rigid frame on which metallic wires are fixed and form a flexible mesh inside the frame distorting around the food.

**3.10 Barbecue** — Appliance designed principally to roast and/or grill food.

NOTE — Cooking is carried out by radiant heat and, possibly, by convection and conduction.

**3.11 Griddle** — Part of a stove consisting of a plate placed above a burner, that allows the cooking of food by direct contact with the surface of the plate which is brought to a high temperature.

**3.12 Stabilizer** — Part of the appliance designed to increase mechanical stability.

**3.13 Pan Support** — Support placed above an open stove burner and designed to support the pan to be heated.

**3.14 Turnspit** — Cooking device enabling the rotation of the food to be roasted.

NOTE — The rotation can be manual or using a mechanical or electrical motor (battery).

**3.15 Glass Panel** — Glass surface or part of a glass surface allowing the inside of an enclosure to be seen.

**3.16 Fittings** — Safety devices, controlling devices or regulating devices and sub-assemblies thereof, designed to be incorporated into an appliance or to be assembled to constitute an appliance.

NOTES

1 For example, valves, flame supervision devices.

2 Cartridge is not considered as fittings.

**3.17 Flame Supervision Device** — Device which, due to the presence of a flame on the sensing element, keeps open the gas flow to the burner and any pilot and which cuts off the gas supply to the burner and possibly a pilot in the event of extinction of the supervised flame.

**3.18 Ignition Delay Time** — Time between the ignition of the supervised flame and the moment when the effect of this flame is sufficient to keep the closing device open.

**3.19 Extinction Delay Time** — Time between the extinction of the supervised flame and the closure of the gas supply to the burner and possibly a pilot.

**3.20 Tap** — Controlling device, part of the appliance, designed to isolate a burner from the internal gas pipework and possibly to adjust its rate during use.

**3.21 Control handle** — Component designed to be operated manually so as to operate a control of the appliance.

NOTE — For example, a tap, thermostat etc.

**3.22 Gripping Area** — Outside part of the appliance designed to be handled during use.

**3.23 Burner** — Component that allows the gas to burn.

NOTE — Two types of burners are distinguished:

- a) Ignition burner — Small burner whose flame is designed to light a main burner. It is referred to as ‘pilot’ in this Standard.
- b) Main burner — Burner designed to fulfil a thermal function of the appliance. It is referred to as ‘burner’ in this Standard.

**3.24 Injector** — Component part that admits the gas into a burner.

NOTE — An injector is said to be calibrated when the section of the outlet orifice is fixed.

**3.25 Ignition Device** — Device to ignite one or more burners directly or indirectly.

**3.26 Primary Air Adjuster** — Device allowing the modification of the primary air rate.

NOTE — The action consisting in operating this device is termed ‘primary air adjustment’.

**3.27 Means of Sealing** — Static or dynamic device designed to ensure leak tightness.

NOTE — For example, flat-faced joints, O-ring or conical joints, diaphragms, grease, pastes, putties etc.

**3.28 Detachable** — Possible to dismantle without using a tool.

**3.29 Removable** — Removal only possible with a tool.

**3.30 Soft Solder** — Solder for which the lowest temperature of the melting range, after application, is less than 450 °C.

**3.31 Flame Stability** — Flames are stable at the burner ports when the phenomena of flame lift or light back do not occur.

**3.32 Flame Lift** — Phenomenon characterized by the partial or total movement of the base of the flame away from the burner port.

**3.33 Light Back** — Phenomenon characterized by the return of the flame inside the body of the burner.

**3.34 Calorific Value (Heat of Combustion)** — The number of heat units liberated by the complete combustion of unit volume or mass of gas under specific conditions.

- a) *Gross Calorific Value* — The sum of the number of heat units liberated by the complete combustion of the unit volume or mass of gas and heat released by

condensation of water vapour produced from the condition; and

- b) *Net Calorific Value* — The gross calorific value minus the heat released by the condensation of water vapour produced from the combustion.

**3.35 Gas Supply Pressure** — Difference between the static pressure measured at the gas inlet connection of the appliance and the atmospheric pressure. It is expressed in bar.

## 4 CLASSIFICATION

### 4.1 Classification of Gas

Gases likely to be used are classified in three groups according to their pressures: (*see* IS 4576)

- a) *Commercial Butane (referred as Gas A)* — A hydrocarbon product composed predominantly of butanes, butylene or their mixtures.
- b) *Commercial Butane — Propane mixture (referred as Gas B)* — A hydrocarbon product composed predominantly of a mixture of butanes and/or butylene with propane and/or propylene.
- c) *Commercial Propane (referred as Gas C)* — A hydrocarbon product composed predominantly of propane, propylene or their mixture.

### 4.2 Category of Appliances

Appliances are classified in three categories according to the gases likely to be used:

- a) Category direct pressure — Butane;
- b) Category direct pressure — Butane-propane mixture; and
- c) Category direct pressure — Propane.

## 5 SAFETY REQUIREMENTS

### 5.1 General

The test methods and the means of verification are indicated in [6](#). The design shall make it impossible to incorrectly fit or refit any user-removable or replaceable part(s) or component(s) that can have an adverse effect on combustion or cause CO emissions to exceed limits in [5.26](#).

### 5.2 Adjustment of the Burner

For appliances of types a), b) and c), referred in the scope of this Standard, no adjustment of the burner shall be possible.

### 5.3 Materials

The quality and thickness of materials used in the construction of appliances shall be such that the constructional and performance characteristics are not altered in use. In particular all the parts of the appliance shall withstand mechanical, chemical and thermal actions to which they may be submitted during use. In normal conditions of operation, of cleaning or of adjustment, they shall not be liable to any alterations which might impair their safety. Sheet-metal parts, not made of corrosion-resistant material, shall be effectively protected against corrosion.

This requirement does not apply to grills supporting lava rocks or to cooking devices. The body of the appliance valve shall be made out of any of the following materials.

- a) *Copper and Copper Alloy Forging* — Specification IS 6912 or material as specified in 4 of IS 8737 for valve body;
- b) *Zinc Alloy of Grade* — ZnAl4 or ZnAl4Cu only; and
- c) *Aluminum Alloy* — LM6, LM24 – IS 617.

#### 5.3.1 Washers, O-Seals and Jointing Compounds

All washers, 'O' seals [see IS 17891 (Part 1 to 5)] and jointing compounds for use in liquefied petroleum gas appliances and installations coming into contact with the gas shall be suitable for use with liquefied petroleum gas. Hoses being part of the appliance shall be LPG resistant and conforming to IS 9573 (Part 2). Copper or copper alloy tubing shall be used upstream of the injector only if its temperature does not exceed 100 °C when the test described in 6.21 is carried out. Asbestos or asbestos based material shall not be used. The nature and finish of materials likely to be in contact with food shall be such that they cannot contaminate or effect the food.

### 5.4 Assembly, Cleaning, and Maintenance

#### 5.4.1 Assembly

The entire appliance gas circuit, including the injector and flexible hoses if any, shall be factory assembled by the manufacturer. If clamps are used, they shall be of the machine formed type. Removable clamps are not permitted. Parts, whose assembly is carried out by the user, shall be able to be assembled correctly by following the instructions given in the instructions. It shall not be possible to dismantle parts which are adjusted at the factory, which are not intended to be dismantled by the user and whose dismantling would affect safety. Without using tools if dismantling is possible using an open-ended spanner or a screwdriver, direct access to such

nuts and screw heads shall not be possible, unless they are sealed. If a pressure reducing device is integrated in the gas circuit, this device may provide the functions of adjustment, opening and closing of the gas flow. Connections shall allow the flexible hose to move freely without risk of coming into contact with a part of the appliance whose temperature rise exceeds 70 °C during the test defined in 6.21 when fitted in accordance with the instructions.

#### 5.4.2 Cleaning and Maintenance

All parts of the appliance requiring frequent cleaning by the user shall be easily accessible. It shall be possible to put these parts back correctly. There shall be no sharp corners and edges on the accessible parts of an appliance which could give rise to injury, for example during cleaning.

### 5.5 Strength and Stability

#### 5.5.1 Strength

##### 5.5.1.1 General

The construction of an appliance shall be such that during normal conditions of use:

- a) Any displacement of parts;
- b) Any distortion; and
- c) Any deterioration.

Likely to impair safe operation will not occur.

##### 5.5.1.2 Cooking appliance stoves: strength and rigidity

The cook top/cook top and burner assembly of the cooking appliance shall be placed on the cylinder and an appropriate reference distance between the center of the appliance and the body of the cylinder measured. A load of 250 N (25 kg) shall be applied at the top surface of the cook top. The load shall be maintained for 5 min after which the measurement of dimension is taken again with the load in position. The resultant deflection measured shall not exceed 2 mm.

NOTE — This clause is applicable to the cooking appliances mounted on the cylinders only.

##### 5.5.1.3 Stove pan supports

The application of a mass as described in 6.5.1.2 on the pan support shall not cause any breakage or permanent distortion of the pan support exceeding 1 mm.

##### 5.5.1.4 Glass components

The accessible edges of glass components shall not be sharp. They shall withstand the various stresses

to which they are subjected during the tests described in this Standard without damage. In particular they shall withstand the test described in [6.5.1.3.1](#) (when they are a part of the appliance) and in [6.5.1.3.2](#).

### 5.5.2 Stability

If the appliance is fitted with a foldable support, it shall be possible to lock this in the position of use (for example, stop, locking device). The stability of an appliance designed to rest on a table or on the ground or appliances fitted directly on gas container shall allow safe use on level ground. In addition, the appliance shall not tilt or fall over when it is placed on a slope of 10° and any lid shall not close. This requirement shall also be met when the appliance is fitted with optional parts (for example, lamp extension posts). These requirements shall be met under the test conditions described in [6.5.2](#).

### 5.6 Soundness of the Gas Circuit Assembly

Holes for screws, pins etc, intended for the assembly of components shall not open into the space reserved for the gas ways leading to the injector.

The soundness of part and assemblies connected to the gas circuit shall be ensured by means of metal-to-metal joints or joints with seals (for example, flat-faced joints, O-rings or gaskets), that is, excluding the use of any product which ensure soundness in the threads. For parts that do not require to be dismantled during normal maintenance, for example in valves, the use of thread sealing compound is permitted.

Removable components or the threaded parts of the gas pipe work which may be dismantled during normal maintenance described in the instructions shall remain sound after five disconnections and re-connections in accordance with the instructions, if necessary after changing a gasket.

Soft solder (*see* [3.30](#)) shall not be used to ensure the soundness of the gas circuit. However, it is permitted for internal connections within the gas circuit when they do not involve soundness. Conformity shall be verified based on the manufacturer's specifications.

Under the test conditions defined in [6.6.1](#), during each of the test no.1 and 2, the leak shall not exceed 4 Nmm<sup>3</sup>/s (The symbol 'N' indicates conversion to normal temperature pressure condition, NTP that is 760 mmHg pressure and 0 °C temperature). This requirement shall also be met after all the tests on the appliance have been carried out, but before any dismantling of parts subjected to the soundness tests.

After the application of a load to the flexible hose under the conditions defined in [6.6.2](#), no leak greater than 4N mm<sup>3</sup>/s (1 013 mbar, 20 °C) shall be recorded.

## 5.7 Connections

### 5.7.1 General

Whatever the type of gas cartridge or gas cylinder when following the instructions, connection of the appliance to the gas cartridge or gas cylinder shall be easy without gas leakage during more than 2 s.

#### 5.7.1.1 Appliances connected to refillable gas cylinder with self-closing valves of threaded and clip-on outlets

Gas containers shall not be greater than 13 liters water capacity for the efficient operation of the appliances for which they are designed. Refillable gas containers used with these appliances shall comply with IS 7142 or IS 12586 or IS 3196 (Part 1).

#### 5.7.1.2 Appliances connected to the gas container by a flexible hose

Appliances connected to the gas container by a flexible hose shall be supplied with the flexible hose fitted.

Hose connection shall be with threaded fittings at both the ends. If clips are used, they shall be of the machine formed type. Screw clips are not permitted. Connections shall allow the flexible hose to move freely without risk of coming into contact with a part of the appliance whose temperature rise exceeds 70 °C during the test defined in [6.21](#) when fitted in accordance with the instructions. After the application of a load to the flexible hose under the conditions defined in [6.6.2](#), no leak greater than 4 N mm<sup>3</sup>/s shall be recorded.

#### 5.7.2 Appliances intended to be Directly Fitted to the Gas Cartridge or Gas Cylinder

##### 5.7.2.1 Appliances connected to pierceable cartridges

If it is intended that the container or the closure shall be pierced to use its contents, the container shall be so designed in conjunction with the appliance with which it is to be used that it is not reasonably possible to operate the piercing device to pierce the container unless the container is properly attached to the appliance.

- a) Design/construction of the appliance shall be such that there is no foreseeable

replacement procedure sequence possible which can lead to an unsafe and/or unintended piercing of the cartridge by the user.

NOTE — See in informative Annex D examples of authorized solutions given in Fig. D-1 to Fig. D-7.

- b) The cartridge holder and the piercing device shall be such that:
  - 1) The piercing is centered in the position provided;
  - 2) Soundness is ensured before piercing; and
  - 3) After placing the cartridge, it shall not be possible to remove it, instantaneously and/or unintentionally, without first having to remove the piercing device. Diagrams showing the correct sequence for the fitting of the cartridge to the appliance shall be marked on the appliance.
- c) Concerning the compatibility between the piercing device and the cartridge.
- d) Piercing device should open and not damage the cartridges.

Piercing device should be, such as the needle length penetrates cartridge for a distance between 7 mm and 9 mm (see Fig. 3).

**5.7.2.2 Appliance fixed on to cartridges with female valve and threaded center boss (see Fig. 4)**

**5.7.2.2.1** The female thread of the adaptor (Fig. 5) designed to be fixed on to the thread of the center boss valve is defined as follows:

7/16 in – 28 threads unified form special – (see Fig. 6);

- a) Major diameter : 10.96 mm minimum;
- b) Effective diameter : 10.66 mm to 10.75 mm; and
- c) Minor diameter : 10.20 mm to 10.27 mm.

**5.7.2.2.2** The part of the adaptor, with a full thread, shall be 3.10 mm ± 0.1 mm long (see Fig. 5A).

**5.7.2.2.3** The thread shall penetrate fully into the seal groove without reduction in form.

**5.7.2.2.4** A valve actuator shall be fixed on the axis of the adaptor in such a way that it allows the drawing of gas from a full cartridge in accordance with 5.7.1. The valve actuator shall allow the release of gas from the cartridge when the appliance is screwed on to the valve with a minimum torque of 3 nm.

**5.7.2.2.5** The diameter of the valve actuator shall not exceed 2.20 mm if it is solid and shall be between 3.10 mm and 3.15 mm if it includes a gas way as indicated in Fig. 4. The valve actuator shall be concentric with the ‘7/16 in - 28 Unified form thread’ subjected to a tolerance of 0.15 mm [see Fig. 5A) and 5B)].

**5.7.2.2.6** At the point where the valve actuator comes into contact with the valve seat, the valve actuator diameter shall be at least 1.70 mm [see Fig. 5A)]. It is recommended that adaptor manufacturers contact the manufacturers of cartridge valves to establish the preferred design [see Fig. 5B)]. The valve actuator shown in Fig. 5B) comes in contact with the inner seal of the valve ensuring complete soundness when the cartridge is fitted.

**5.7.2.2.7** A seal groove shall be machined at the bottom of the threaded part so as to center and secure a seal [see Fig. 5A)]. This seal shall come in to contact with the valve center boss. The seal and the seal groove shall be such that there is no visible and permanent distortion of the threaded centre boss when the appliance is screwed on to the valve with a torque on 12 nm.

**5.7.2.2.8** The length of the valve actuator shall be such that it does not penetrate in to the valve for a distance exceeding 4.15 mm below the plane of the upper side of the centre boss (see Fig. 7, dimension X) when the appliance is screwed on to the valve with a torque on 12 nm.



FIG. 1 EXAMPLES OF CLOSING POSITIONS



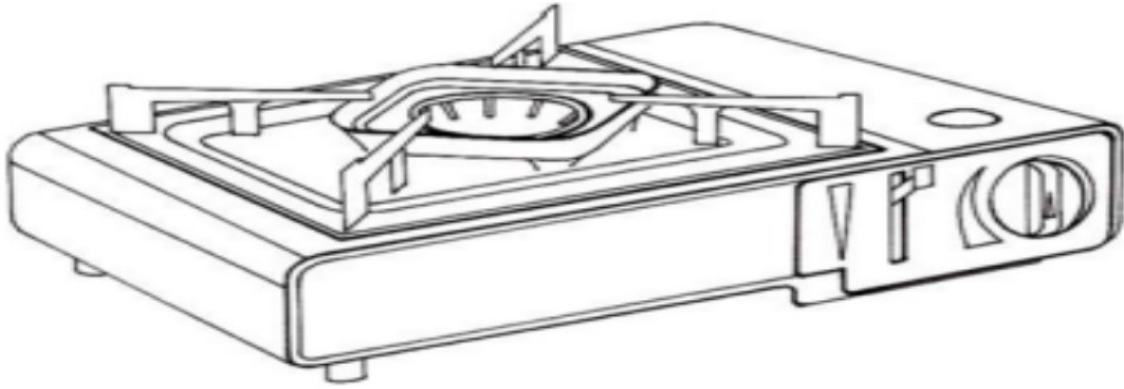
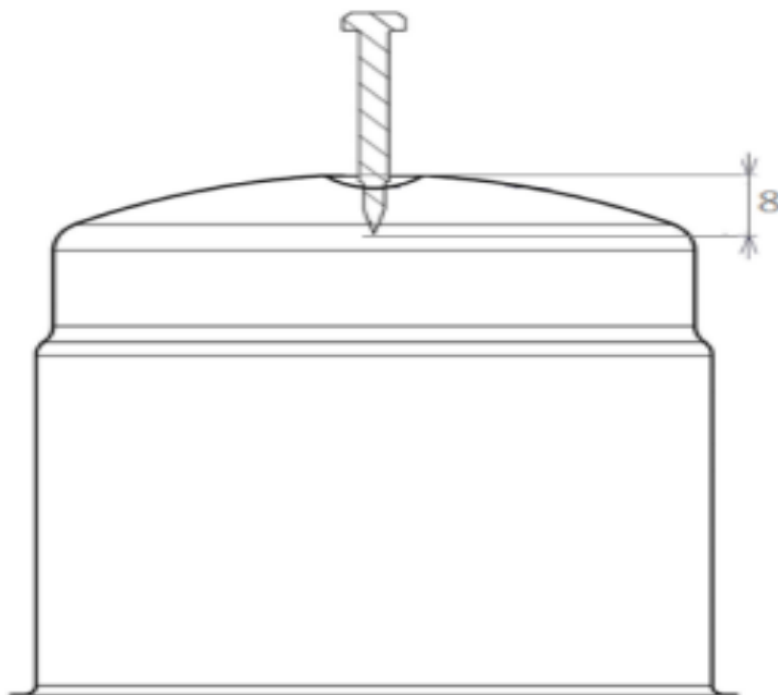
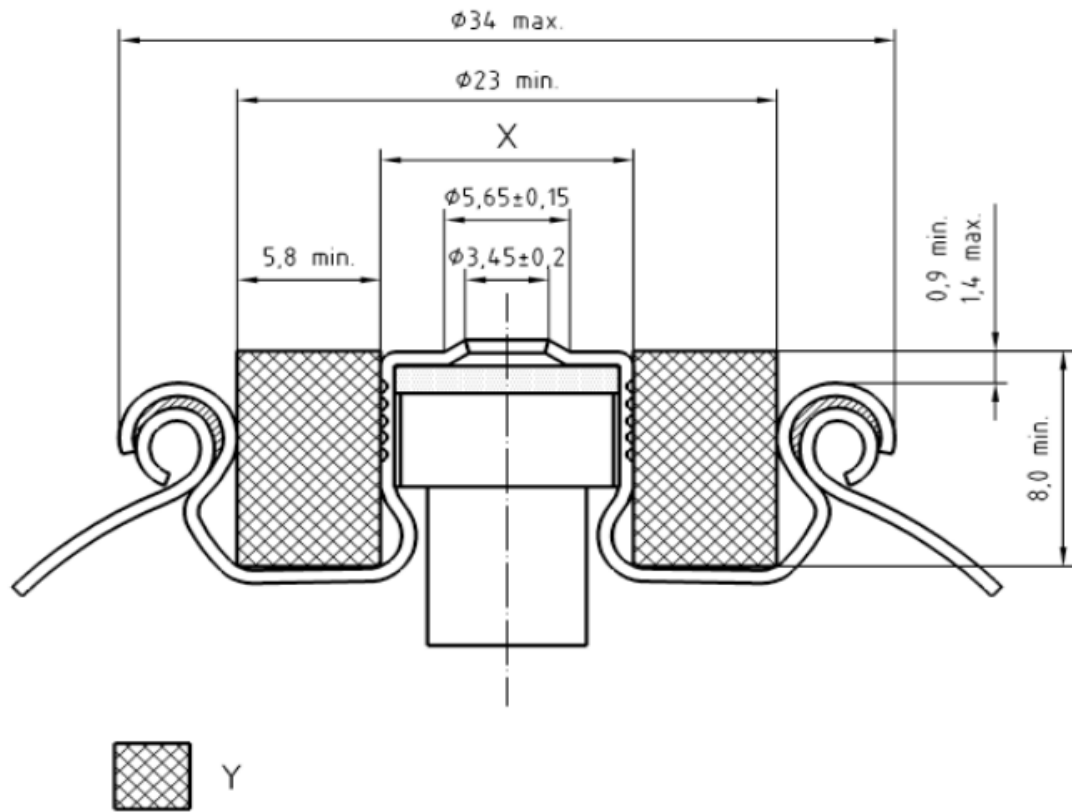

FIG. 2 EXAMPLE OF A FLAT PORTABLE GAS STOVE



All dimensions in millimetres.

FIG. 3 PENETRATION OF THE CARTRIDGE : PENETRATION  
DISTANCE BETWEEN 7 AND 9 mm, E.G:8 mm



Dimensions in millimetres.

FIG. 4 CROSS SECTION OF VALVE WITH CENTRE BOSS (see [5.7.2.2](#))

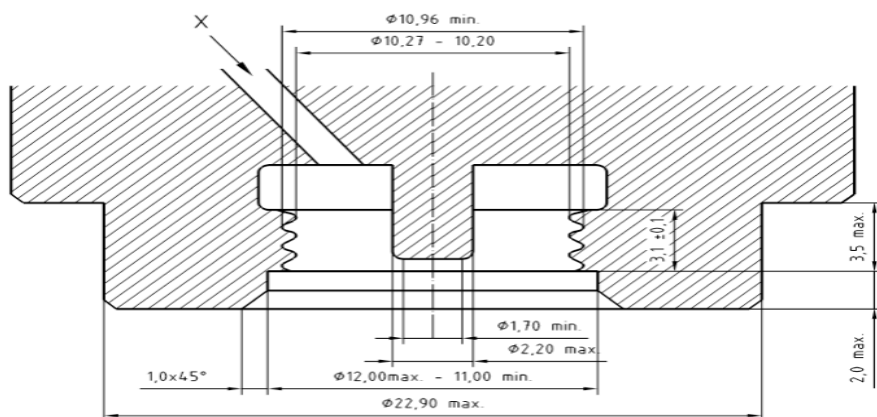

dimensions in millimetres.

5A APPLIANCE ADAPTOR WITH SOLID GAS RELEASE DEVICE

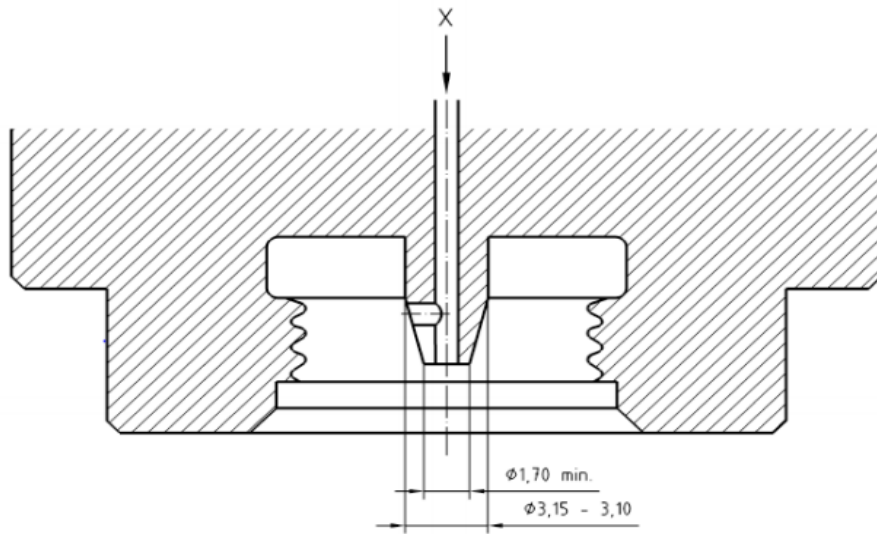

dimensions in millimetres.

5B APPLIANCE ADAPTOR WITH HOLLOW GAS RELEASE DEVICE KEY X GAS PASSAGE

FIG. 5 APPLIANCE WITH SOLID/HOLLOW GAS RELEASE DEVICE

(see [5.7.2.2.2](#), [5.7.2.2.5](#), [5.7.2.2.6](#), [5.7.2.2.7](#), [5.7.2.2.9](#) and [5.7.2.2.10](#))

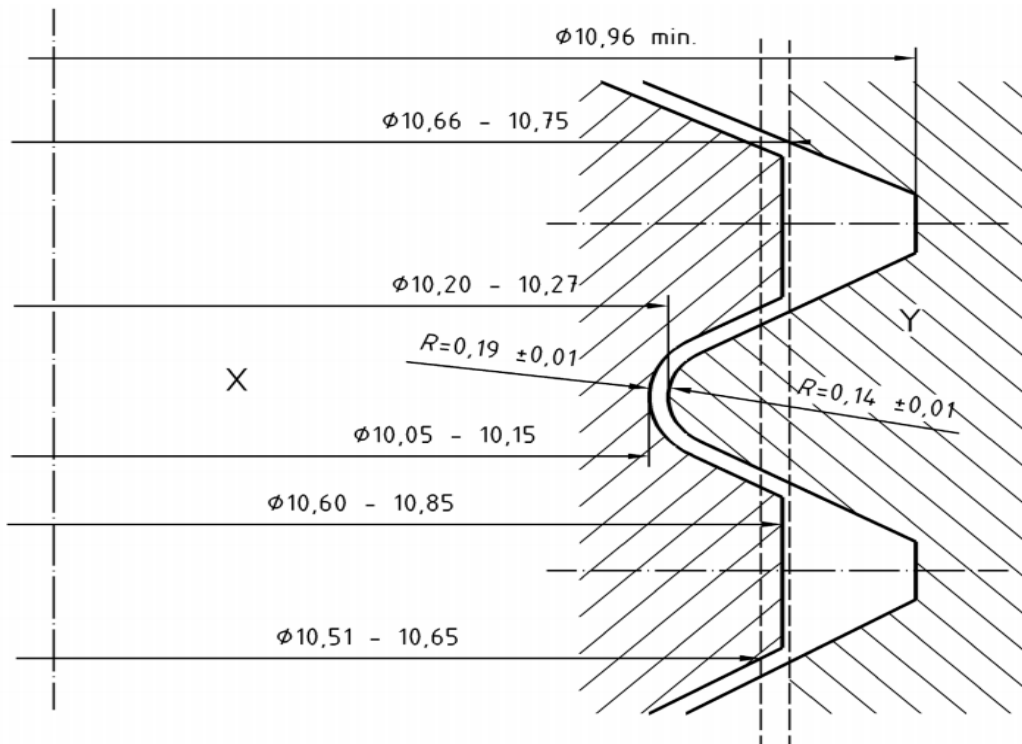

Key  
 X valve  
 Y Adaptor

dimensions in millimetres.

FIG. 6 TOLERANCES OF VALVE AND ADAPTOR THREADS (see [5.7.2.2.1](#))

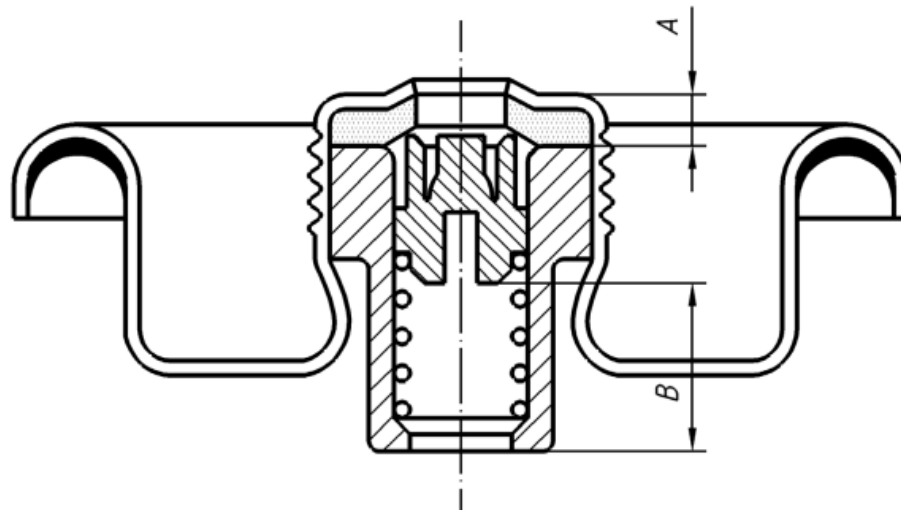

a) VALVE FULLY CLOSED

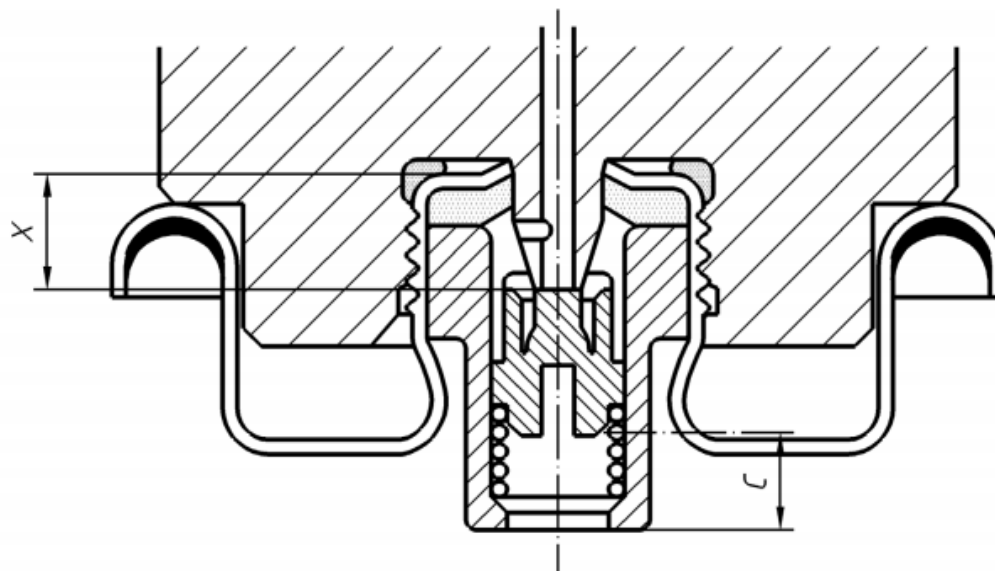

b) VALVE FULLY OPENED

dimensions in millimetres.

FIG. 7 RELATIVE DIMENSIONS OF THE OPENING OF THE VALVE BY THE ADAPTOR

(see [5.7.2.2.8](#) and [6.7.2.2.4](#))

**5.7.2.2.9** The inlet of the adaptor prior to the thread shall be a maximum of 2.00 mm deep and have a diameter of between 11.0 mm and 12.0 mm. In addition, the inlet of the adaptor shall begin with a 1.0 mm  $\times$  45° chamfer [see [Fig. 5B](#)].

**5.7.2.2.10** The diameter of the adaptor which penetrates the valve seal groove shall not exceed 22.90 mm. This part shall not extend more than 3.5 mm from the start of the adaptor thread [see [Fig. 5A](#)].

**5.7.2.2.11** The diameter of the adaptor beyond the 3.5 mm distance as defined in [5.7.2.2.10](#) shall be at least 30.0 mm. It shall be designed so as to rest on the rolled edge of the outer rim when fixing the appliance onto its cartridge, and after the seal ensuring soundness has come in contact with the cartridge valve. If the appliance incorporates other parts at this point (for example, blowtorch handles, plastic mouldings), the requirements of [5.7.2.2.10](#)

and [5.7.2.2.11](#) shall be met, when these parts are in position.

**5.7.2.2.12** The requirements of [5.7.2.2](#) shall be verified under the test conditions given in [6.7.2.2](#).

**5.8 Transport, Fixing and Mobility Devices**

An appliance fitted with a device which, in accordance with the instructions, allows its transport and/or fixing (for example, handles) shall be capable of being carried and/or hung without causing permanent distortion of parts of the appliance. This requirement shall be verified under the test condition defined in [6.8](#).

Wheels allowing the movement of the appliance shall be sufficiently strong to support the appliance and, if necessary, its full cartridge or gas cylinder, if this is specified in the instructions. If the appliance has wheels, means shall be provided to prevent accidental movement during use.

**5.9 Taps**

**5.9.1 General**

Each burner shall be controlled by a tap or device allowing the opening and closing of its supply. For appliances incorporating only one burner, this closing device may be that of the gas cartridge or gas cylinder Taps shall incorporate two stops, one on the closed position and one at the end of travel. Taps shall be so placed in such a way that their strength, their operation, their manipulation, and their accessibility undergo no change from actions to which they are subjected in normal use. Taps shall be mounted in such a way that no accidental movement related to fixed gas supply pipe work is possible.

**5.9.2 Needle Valves**

It shall not be possible to unscrew the needle from the housing of needle valves when opening the valve. When closing, the pressure of the needle on its seat constitutes the stop. Needle valves shall comply with the requirements given in [Annex C](#).

**5.10 Control Handles**

**5.10.1 Construction**



It shall be obvious which burner is controlled by each control handle. They shall be so arranged relative to one another that the movement of one handle does not cause inadvertent movement of an adjacent one. Control handles shall be so designed that they neither be fitted in the wrong position nor move by themselves. If control handles operate by turning, the closing direction shall be clockwise.

**5.10.2 Marking**

**5.10.2.1 Taps with marked positions (for example, plug type valves)**

The closed, open and, if applicable, reduced rate positions shall be marked in a visible, legible and durable fashion. The closed position shall be marked by a full disc or a circle at least 3 mm in diameter. It shall be the same for all the valves.

The identification of the closed position of each valve shall not give rise to any possibility of confusion with the identification of an open position. For other positions, the following symbols may be used:

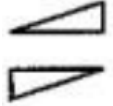
Full rate position	Large flame	
Reduced rate position	Small flame	
Rate range	Triangle	

or

Scale 1 2 3 4 or 4 3 2 1

Other symbols, other than letters, are permitted provided that they give similar information clearly. Additional markings are permitted provided that they do not create confusion for the appliance user. The meaning of the symbols used shall be given in the instructions.

**5.10.2.2 Taps with variable positions (for example, needle valves)**

Markings placed either on the appliance or on the control handles shall be visible, legible and durable and comply with the following requirements:

- a) The closing direction shall be marked by an arrow (possibly stylized) whose tip points to a full disc or circle at least 3 mm in diameter or the mark ‘-’ symbolizing the closing position, for example (Ref. Fig. 1);
- b) Marking of the reduced rate is not required. Additional markings are permitted provided that they do not create confusion for the appliance user; and
- c) The meaning of the symbols used shall be given in the instructions.

**5.11 Injectors**

The gas rate shall be controlled by an injector of

which the outlet orifice is fixed. Removable injectors shall carry an indelible marking allowing their identification, which shall be given in the instructions.

### 5.12 Ignition Devices

When an ignition device is fitted, it shall be designed and constructed in such a way that it provides rapid and safe ignition. The components of the ignition device shall be designed to avoid damage and displacement during use. The relative positions of the ignition device and the burner shall be sufficiently well defined to ensure safe operation of the assembly.

### 5.13 Flame Supervision Devices

When flame supervision devices are fitted, they shall be designed in such a way that, in the case of the failure of any of the component indispensable to their performance, the supply of the gas to the burner and to the pilot controlled by the device is cut off automatically and can only be restored by manual operation. They shall be so mounted as to ensure satisfactory performance. The appliance shall not incorporate any device that allows the flame supervision device to be over hidden during the ignition period, a brief passage of unlit gas is permitted under the condition given in [6.13](#). Heating appliances, other than those supplied by cartridges (having a maximum capacity of 500 ml), shall be fitted with a flame supervision device. Under the test conditions described in [6.13](#), the ignition delay time shall not exceed 20 s and the extinction delay time shall be less than 60 s.

### 5.14 Burners and Radiant Elements

Burners and radiant elements shall be designed in such a way that they cannot move inadvertently during use or movement of the appliance. The parts of a burner or a radiant element which require cleaning shall be removable and their cleaning shall be easy unless this is possible without dismantling. It shall not be possible to reassemble removable burner parts incorrectly and they shall not be interchangeable, if by design they are not identical. This shall be carried out in accordance with the information given in the instructions. It shall be possible to the user to check that the burners are alight. Cross lighting devices shall have a fixed position relative to the burners that they control and shall not distort in normal use. Under the test conditions defined in [6.6.3](#), there shall be no leak of gas in a flammable quantity at the joints of the assembly of burners made up of several parts of burners on the body of the appliance.

### 5.15 Grids

#### 5.15.1 General

Grids shall be detachable, when their height can be adjusted in accordance with the instructions while the burner is alight, they shall be provided with a fixed, moveable or detachable handle.

#### 5.15.2 Grid with a Rigid Useful Area

In the useful area of the grid, the bars, if any, shall not be more than 2 cm apart. The grid shall be capable of withstanding without deterioration likely to impair its use, the load described in [6.15](#). Under this load, it shall remain stable on its supports.

### 5.16 Turnspit

Any turnspit shall be fitted with a fixed or detachable handle. This requirement is considered to be satisfied if a motor forming a handle is used. The useful length of the handle shall be at least 80 mm. When the distance between the support points of the turnspit is greater than 800 mm, there shall be a second handle, unless the motor can be used as a second handle. In order to hold the food to be grilled, the turnspit shall be fitted with one or several adjustable, lockable devices. When the turnspit is loaded as described in [6.16](#), it shall be stable on its supports.

### 5.17 Fireguards for Heating Appliances

Heating appliances shall be fitted with a guard meeting the strength and dimensional requirements indicated in a) and b):

#### a) Strength of Fireguards:

- 1) Probe test — It shall not be possible to touch any burner radiant, catalytic panel or a flame with any part of the test probe cone illustrated in [Fig. 11](#), even after the application of the test weight described in [6.17.1.1](#).
- 2) Pull test — The guard shall not be removed, displaced or permanently distorted when tested as described in [6.17.1.2](#).
- 3) Glass fronted appliances — When the design of the guard includes glass or similar material this material shall not be damaged by the impact test described in [6.17.1.3](#).

#### b) Dimensions

No opening in the guard or between the guard and the aperture to be protected shall

have dimensions exceeding:

Length 150 mm  
Width 35 mm  
Diagonal 154 mm

Where a part of the fireguard comes within 3 mm of the aperture to be protected it shall be considered that the part reaches the edge of the aperture to be protected. These dimensions are subject to the following exceptions:

- 1) Where it is not possible to pass a 12 mm diameter probe having a hemispherical end through any opening between the guard and the aperture to be protected. The probe shall be applied with a force of 5 N to the guard, the weight of the probe being taken into account; and
- 2) Where the gap between any vertical rods does not exceed 5 mm.

## 5.18 Locations and Compartments for Cartridge or Gas Cylinder

### 5.18.1 Compartments for Refillable Gas Containers

When the appliance has an area designed to support a gas cylinder, it shall incorporate a device allowing the safe fixing of the cylinder onto the appliance. This compartment shall be designed in such a way that:

- a) Effective ventilation is provided by openings in its base and upper section. The total area of the openings in the upper section shall be at least equal to 1 percent of the base area of the compartment and the total area of the openings at the base at least equal to 2 percent of the base area of the compartment, each opening being at least 3 mm<sup>2</sup>;
- b) The openings shall not be blocked (for example, by labels);
- c) The support for the gas cylinder has sufficient mechanical strength to resist permanent distortion under the load of a full gas container;
- d) When it is in place it shall be vertical;
- e) The gas container valve if any is readily accessible and remains easy to manipulate when the gas cylinder is in place;
- f) When the appliance may be connected by a flexible hose, of the length indicated in the instructions, the hose shall not come into contact with sharp edges; and
- g) Where the gap between any vertical rods does not exceed 5 mm.

### 5.18.2 Compartment for Gas Cartridge

This compartment shall be designed in such a way that effective ventilation is provided by openings in its base. The total area of the openings at the base at least equal to 3 percent of the base area of the compartment, each opening being at least 3 mm<sup>2</sup>. The openings shall not be blocked (for example, by labels).

## 5.19 Verification of the Heat Inputs

Under the test conditions defined in [6.19](#), each of the burners, supplied separately, shall be capable of giving the nominal heat input stated in the instructions with a tolerance as illustrated in [Fig. 8](#).

## 5.20 Resistance to Overheating

No deterioration which could impair the safety of the appliance shall be evident after the test described in [6.20](#).

## 5.21 Temperature of Various Parts of the Appliance

### 5.21.1 Floor Standing or Table Standing Appliances

Under the test conditions defined in [6.21.2.1](#), the surface temperature of the various parts of the appliance specified below shall not exceed the following limits.

- a) The surface temperature of the parts likely to be touched during normal use (for example, tap handles), measured only in the gripping area, shall not exceed the ambient temperature by more than:
  - 1) 35 °C for metals or equivalent materials;
  - 2) 45 °C for porcelain or equivalent materials; and
  - 3) 60 °C for plastics, wood or equivalent materials.

For turnspit handles and the handles fixed on the sides of barbecue covers, this requirement applies to a 50 mm length measured from the end of the handles.

For barbecue front cover handles, this requirement applies for areas more than 50 mm from fixing points. If the temperature exceeds the permitted limit, the following warning shall appear on the handle: 'Hot handle – use gloves to touch'.

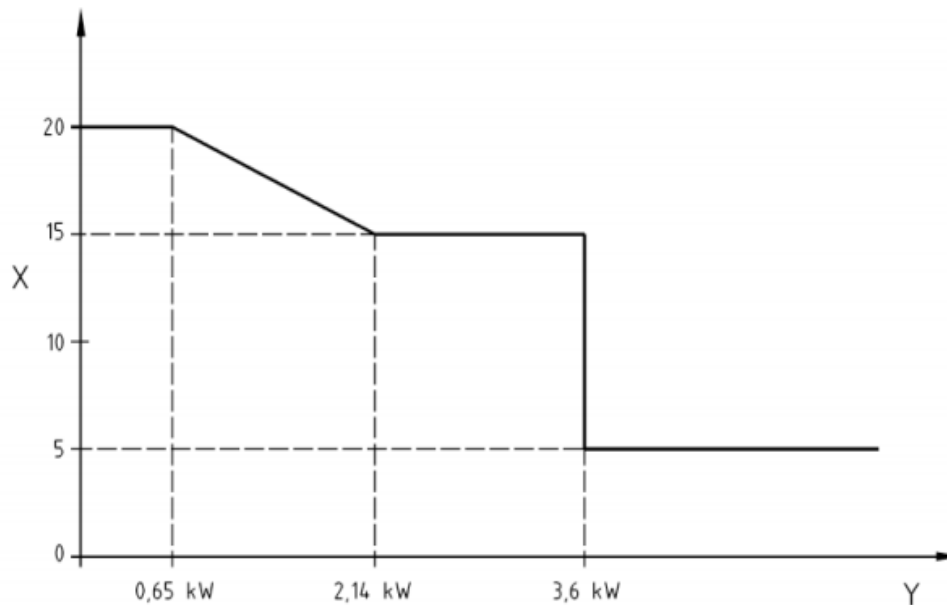

## Key

- X Rate tolerance percent  
Y Nominal rate of the burner

FIG. 8 TOLERANCE ON RATE (see 5.19)

- b) The surface temperature of any gas cartridge or gas cylinder valve handle shall not exceed the ambient temperature by more than 35 °C.
- c) The surface temperature of connections (for example, nozzles) in contact with the flexible hose shall not exceed the ambient temperature by more than 30 °C. The temperature of appliance parts likely to come in contact with the flexible hose, when fitted in accordance with the instructions, shall not exceed the ambient temperature by more than 70 °C.
- d) The surface temperature of fitting shall not exceed the maximum temperature stated in the technical specification of the fitting.
- e) Temperature measured on accessible surfaces of the front and side panels of the appliance that can be accidentally touched shall not exceed the ambient temperature by more than:
- |                         |          |
|-------------------------|----------|
| metal and painted metal | : 60 °C  |
| enameled metal          | : 65 °C  |
| glass and porcelain     | : 80 °C  |
| plastics and wood       | : 100 °C |

This requirement (e) does not apply to barbecues or heating appliances.

**5.21.2 Appliances Design to be Held During Use**

Under the test condition defined in 6.21.2.2, the surface temperatures of the various parts of the appliance shall not exceed the following limits:

- those indicated in 5.21.1; and
- 25 °C or 10 °C beyond the ambient temperature whichever is higher for handles intended to be held during use.

**5.22 Temperature of Panels (Floors, Walls or Ceilings)****5.22.1 Floor and Table Standing Appliances**

The surface temperature of the appliance support shall not exceed the ambient temperature by more than 70 °C and 50 °C for walls. If the temperature rise of the support exceeds 50 °C, the instructions shall indicate the conditions of use of the appliance, more particularly he shall specify the type of surface protection to be used.

**5.22.2 Appliances Intended for Suspension**

If the instructions allow the use of the appliance when it is suspended from a ceiling or wall (for example, a lamp), the rise in temperature of the panel used as the



ceiling or wall, as appropriate, shall not exceed the ambient temperature by more than 50 °C.

### 5.23 Ignition, Cross Lighting and Flame Stability

Under the test conditions defined in [6.23](#):

- a) Ignition cross lighting and re-ignition shall occur smoothly within 5 s;
- b) Sixty seconds after ignition, flames shall be stable. A tendency to lift is permitted at maximum test pressures;
- c) There shall be no extinction or light back; and
- d) The gas supplying burners which are not protected by a flame supervision device shall light automatically and smoothly if a burner is already operating within the same enclosure.

### 5.24 Resistance to Draught

Under the conditions defined in [6.24](#), neither burner nor pilots shall be extinguished, unless the appliance is fitted with a flame supervision device.

### 5.25 Resistance to Liquid Spillage

Under the conditions defined in [6.25](#), neither burners nor pilots shall be extinguished.

### 5.26 Combustion

Under the conditions defined in [6.26](#), the quantity of CO in the air and water vapour free products of combustion shall not exceed 0.2 percent.

### 5.27 Accumulation of Un-Burnt Gas

Any enclosure containing at least one burner shall have one or several openings in its lower part allowing the discharge of un-burnt gas which might be released by the burners.

NOTE — Burner in an enclosure: any burner enclosed or partially enclosed in the body of the appliance in such a way that un-burnt gas released by that burner can accumulate in the appliance.

These openings shall not be obstructed when the appliance is in the position of normal use (for example, appliances operating when they are placed on the surface).

### 5.28 Safety at High Temperature

During the test described in [6.28](#), the pressure inside

the gas container shall not exceed the pressure of the gas contained at 65 °C. After this test:

- a) there shall be no deterioration which could impair safe operation of the appliance;
- b) the appliance shall meet the requirement of [5.6](#); and
- c) the ease of changing the gas cartridge or gas cylinder and manipulating the controls shall not have changed.

### 5.29 Shooting – Condensation

At the end of all the tests in this standard, no deposit of soot likely to impair safe operation of the appliance shall be observed.

During all the test of this standard, condensation shall not create phenomena likely to impair safe operation of the appliance.

### 5.30 Rational Use of Energy

#### 5.30.1 Efficiency of Stove Burners

##### 5.30.1.1 General

The requirements given in [5.30.1.2](#) and [5.30.1.3](#) do not apply to stove burners whose nominal heat input is less than 1.16 kw.

##### 5.30.1.2 Uncovered burners

The efficiency determined under the conditions defined in [6.30.1](#) shall not be less than 50 percent. This value is reduced to 45 percent for stove for use with special pans having a pan diameter less than 150 mm.

##### 5.30.1.3 Covered burners

The efficiency determined under the conditions defined in [6.30.2](#) shall not be less than:

- a) 25 percent (from the cold condition); and
- b) 35 percent (from the hot condition).

### 5.31 Durability of Markings

The durability of markings is considered satisfactory if, at the end of the tests in this Standard, markings are still visible and legible after the test described in [6.31](#).

### 5.32 Strength and Endurance Requirements

After the components linked to the safety of the appliance having been submitted to the tests given

in [6.32](#) the appliance shall fulfil, without any deformation affecting safety, the requirements of:

- a) Clause [5.6](#) — soundness of the gas circuit assembly; and
- b) Clause [5.26](#) — combustion.

Wherever component specific standards are available, 'Strength and Endurance Requirements' is not required.

## 6 TEST METHODS

### 6.1 General

#### 6.1.1 Test Gases

The composition of the reference gases used for the tests shall be as near as possible to those given in the [Table 1](#) (reference condition: dry gas at 15 °C and 1 013 mbar). For the making up of these gases, the rules below shall be followed.

- a) The wobble number of the gas used shall be within  $\pm 2$  percent of the value indicated in the table above.
- b) The gases used shall have the following minimum degrees of purity:
 

1) Butane C <sub>4</sub> H <sub>10</sub> 95 %	$H_2 + CO + O_2 < 1 \%$ $N_2 + CO_2 < 2 \%$
2) Propane C <sub>3</sub> H <sub>8</sub> 95 %	
3) Propene C <sub>3</sub> H <sub>6</sub> 95 %	

Alternately the standard gas or LPG available in the market shall be used as the gas.

#### 6.1.2 Test Conditions

The tests shall be carried out at an ambient temperature of 25 °C  $\pm$  5 °C, unless otherwise stated in specific test conditions or when a higher temperature is required in order to obtain the required test pressure.

For appliances whose instructions do not allow operation with the lid closed, the tests shall be carried out with the lid open, unless otherwise stated in the test method.

For appliances fitted with a user operated aeration adjuster, the tests shall be carried out with the aeration adjuster in the fully open position (unless otherwise stated in the test method).

#### 6.1.3 Test Gases and Pressures

Depending on the appliance category according to [4.2](#), burners shall be tested with the gases under the pressure conditions given in [Table 2](#).

#### 6.1.4 Test Vessel

By default, the minimum diameter of the vessel to be used for the tests is specified at 180 mm. If the highest dimension of the pan support is more than 152 mm, then the test vessel as defined in [Table B-1](#) with the diameter closest to 125 percent of the largest dimension of the pan support shall be used.

NOTE — The highest dimension of the pan support is the diameter of the circle centered on the burner circumscribed with the pan support (see examples given in [Fig. 14](#)).

**Table 1 Characteristics of the Test Gases**

(Clause [6.1.1](#))

SI No.	Reference gas	Composition	Wobbe Number (on Hs)	Gross Calorific Valve (Hs)	Relative Density to Air
(1)	(2)	(3)	(4)	(5)	(6)
i)	Group butane	G.30 C <sub>4</sub> H <sub>10</sub>	87, 33 MJ/m <sup>3</sup>	49, 47 MJ/kg	2 <b>075</b>
ii)	Group propane	G.31 C <sub>3</sub> H <sub>8</sub>	76, 84 MJ/m <sup>3</sup>	50, 37 MJ/kg	<b>1 550</b>
iii)	Group propene	G.32 C <sub>3</sub> H <sub>6</sub>	72, 86 MJ/m <sup>3</sup>	48, 94 MJ/kg	<b>1 476</b>

ok

**Table 2 Test Conditions**

(Clause 6.1.3)

Sl No.	Test	Clause	Butane Appliances		Butane-propane Mix Appliances		Propane Appliances	
			Test gas	Pressure (bar)	Test gas	Pressure (bar)	Test gas	Pressure (bar)
(1)	(2)	(3)	(4)	(5)	(6)	(7)	(8)	(9)
i)	Soundness	6.6	Air	0.5 8.0	Air	0.5 12.0	Air	0.5 18.0
ii)	Rate and delay times	6.13 6.19	G.30	1.0	G.31	3.0	G.31	7.0
iii)	Over heating	6.20	G.30	0.5	G.30 G.32	0.5 2.0	G.32	3.0
iv)	Temperatures	6.21	With the gas cartridge or gas cylinder intended for the appliance.					
v)	Ignition	6.23	G.30	0.5	G.30	0.5	G.32	3.0
vi)	Resistance to draught	6.24	G.31 G.30	2.0 0.5	G.31 G.30	5.0 0.5	G.31 G.31	9.5 3.0
vii)	Resistance to spillage	6.25	G.31 G.30	2.0 1.0	G.31 G.31	5.0 3.0	G.31 G.31	9.5 7.0
viii)	Combustion	6.26	G.30	0.5	G.30	0.5	G.32	3.0
ix)	Safety at high temperature	6.28	G.31	2.0	G.31	5.0	G.31	9.5
			With the gas cartridge or gas cylinder intended for the appliance.					

## 6.2 Adjustment of the Burner

The requirements of [5.2](#) shall be verified by visual examination.

## 6.3 Materials

The requirements of [5.3](#) shall be verified.

## 6.4 Assembly, Cleaning and Maintenance

The requirements of [5.4](#) shall be verified by visual examination and manipulation of the appliance.

## 6.5 Strength and Stability

### 6.5.1 Strength

#### 6.5.1.1 General

The requirements of [5.5.1.1](#) shall be verified by visual examination of the construction and manipulation of the appliance.

#### 6.5.1.2 Stove pan supports

Immediately following the test [6.28](#) a load, whose mass expressed in kilograms equal to the

number of burners covered by the support multiplied by 5 is applied evenly on the pan support for 1 min. The deformation shall be measured once the load has been removed.

For stoves that, by design, are only for use with a special vessel supplied with the appliance, the test shall be carried out with the vessel filed with water to within 10 mm of the top.

NOTE — The vessel is 'special' if the appliance pan support is designed to receive a vessel with a diameter only slightly larger than that supplied with the appliance.

The requirements of [5.5.1.3](#) shall be met.

### 6.5.1.3 Glass components

#### 6.5.1.3.1 Viewing panels

##### 6.5.1.3.1.1 Resistance to mechanical shock

The appliance being at the room temperature of the test room raise the lid to maximum opening then allowed it to fall. The test shall be repeated after 15 min operation with the appliance being supplied with the gases and pressure indicated in [6.19.1](#) all the valves being at the full rate position. In neither case shall the glass panel show either breakage or changes after dropping the lid.

**6.5.1.3.1.2 Resistance to the thermal shock**

The appliance is operated with the gases and at the pressure indicated in [6.19.1](#) for 15 min, the control handle being in the full rate position (all the burner operating simultaneously if the appliance incorporates more than one burner). 50 ml of water is poured above the mid-line of the panel, across the full width using the device in [Fig. 9](#).

The water may be contained in a distortable vessel which allows spraying of the water onto the glass panel (vertical surface) by pressure. The test shall not be carried out if the glass panel is not subjected to the thermal stress during normal use of the appliance (for example, appliance with a glass panel in a lid, whose instructions for use prohibit operation with the lid closed).

**6.5.1.3.2 Lamp globes**

Five globes shall be placed in an oven until they reach thermal equilibrium at 150 °C they shall then be quickly immersed in a tub of water at  $(20 \pm 5)$  °C. No more than one globe shall break. If one globe breaks, the test shall be repeated on five new globes and none shall break.

**6.5.2 Stability****6.5.2.1 General**

If the appliance is supplied with a stabilizer this shall be fitted before the tests, if the instructions

require its use. For the tests, the gas cartridge or gas cylinder recommended by the instructions shall be placed as specified in the instructions and any appliance lid shall be open.

**6.5.2.2 Stability on an inclined plane**

The appliance, connected to an empty gas cartridge or gas cylinder, is placed on a slope of 10° to the horizontal. Check that (see [5.5.2](#)):

- The appliance does not tilt or fall over;
- Any lid does not close; and
- The gas cartridge or gas cylinder recommended by the instructions do not tilt or fall over in the various positions or configurations of use indicated in the instructions.

The use of a wedge is permitted to avoid the appliance sliding.

**6.5.2.3 Stability on a horizontal plane**

- Stoves* — The stove, connected to an empty gas cartridge or gas cylinder, is placed on a horizontal plane. Vessels with diameters from 120 mm to the diameter corresponding to [6.1.4](#), complying with [Annex B](#), filled with water to a height of 40 mm, are centered on the pan support, then offset by 15 mm. Neither the stove nor the vessel shall tilt or fall over during the test (see [5.5.2](#)).

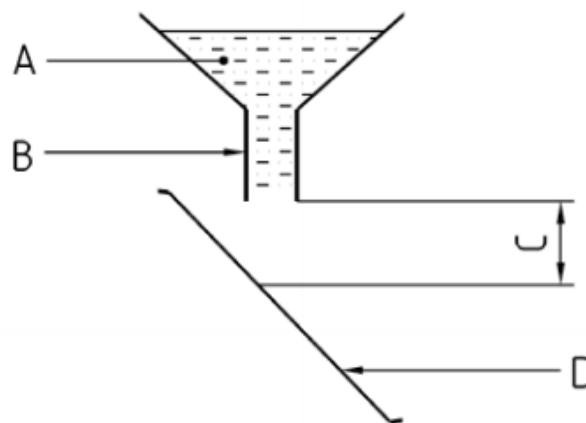
**Key**

50 ml of water at  $(20 \pm 3)$  °C  
 Internal diameter = 2 mm  
 Distance = 20 mm to 50 mm  
 Viewing window

FIG. 9 APPARATUS FOR THE TEST OF RESISTANCE TO THERMAL SHOCK (see [6.5.1.3.1.2](#))

For stove for use with special vessels as defined in [6.5.1.2](#), the test shall be carried out by moving the vessel, filed with water up to 10 mm from the top, of set as far as possible.

- b) *Barbecues* — The appliance, connected to an empty gas cartridge or gas cylinder, is placed on a horizontal plane, check that:
- 1) the positioning and the removal of the cooking devices;
  - 2) the change of the position of the radiant device, if this exists; and
  - 3) the positioning and the removal of the gas container.

Can be carried out (see [5.5.2](#)) without:

- i) The appliance tilting or falling over; and
- ii) Any of the components detaching or moving in such a way that safety is impaired.

For appliances rigidly fixed onto the gas cartridge or gas cylinder, the same checks, with the exception of 3), shall be carried out.

## 6.6 Soundness of the Gas Circuit Assembly

### 6.6.1 Soundness of the Appliance

The requirements of [5.6](#) relating to construction are checked by visual examination and those concerning soundness are checked as follows:

- a) Test No. 1 — with all taps or shut-off devices closed; and
- b) Test No. 2 — with all Taps in the “on” position, the injectors of burners and pilots being temporarily blocked and any shut-off devices, for example the valves of safety devices, where present, in the open position. The tests shall be carried out using air.

The pressure at the inlet of the appliance being:

- 1) 0.5 bar and 8 bar for appliances burning butane.
- 2) 0.5 bar and 12 bar for appliances burning butane/propane mixture.
- 3) 0.5 bar and 18 bar for appliances burning propane.

The appliance shall be connected to a compressed

air supply in the same way as to its supply gas cartridge or gas cylinder.

Any leak shall not exceed the limit given in [5.6](#).

The method used for measuring shall be such that error made in the measurement of the leak is less than 4 Nmm<sup>3</sup>/s.

### 6.6.2 Soundness of Flexible Tube Connections

The appliance is supplied with air at the pressures stated in [6.6.1](#) a force of 150 N is applied for 1 min along the axis of the tube. The test shall be repeated for each end of the flexible tube. Any leak shall not exceed the limit given in [5.7.1.2](#).

### 6.6.3 Soundness of Burner Assemblies

The appliance is operated with gas under the following conditions:

- a) 2 bar for appliances burning butane;
- b) 5 bar for appliances burning butane/propane mix; and
- c) 9.5 bar for appliances burning propane.

A flame is presented to the burner assembly joints as indicated in [5.14](#) and it is checked that there is no leak in flammable quantity.

## 6.7 Connections

### 6.7.1 General

The general requirements of [5.7.1](#) shall be verified by visual examination and manipulation of the appliance with its gas cartridge or gas cylinder. In addition, for appliances with direct, rigid connection to gas cartridge or gas cylinder, the test results shall be compatible with the dimensional and operational information given in the drawings and specifications for the gas cartridge or gas cylinder and their connections.

### 6.7.2 Appliances Directly Connected to Refillable Gas Cylinder

For appliances with direct, rigid connection to gas containers, the test results shall be compatible with the dimensional and operational information given in the drawings and specifications for the gas containers and their connections.

#### 6.7.2.1 Appliances fixed onto pierceable cartridges

The requirements of [5.7.2.1](#) shall be verified by visual examination, dimensional verification and manipulation of the appliance with its gas cartridge.

**6.7.2.2 Appliances fixed onto female valve cartridges with a threaded centre boss**

**6.7.2.2.1 General**

The general requirements of [5.7.2.2](#) shall be verified by visual examination, dimensional verification and manipulation of the appliance with its gas cartridge.

**6.7.2.2.2 Valve opening**

The appliance is screwed on to the cartridge supplied with it with a torque of 3 nm. Check that the valve actuator opens the cartridge valve, and that gas supplies the burner as required by [5.7.2.2.4](#).

**6.7.2.2.3 Resistance to tightening torque**

The test shall be carried out on sample of female valves with a threaded centre boss similar to those fixed on to the specified in the instructions. The valve shall be held tight by the clamp illustrated in Fig. 10, so as to avoid rotation. The appliance adaptor shall be tightened until a torque of 12 nm is obtained at a speed less than 1 nm/s. The appliance adaptor shall then be unscrewed and the requirements of [5.7.2.2.7](#) shall be met.

**6.7.2.2.4 Maximum opening of the valve**

The dimensions shall be measured on a sample of female valve with threaded centre boss and recorded. The dimensions A and B shown in ([Fig. 7](#)) shall be measured on a sample of female valve with threaded center boss and recorded. The valve measured shall be held tight so as to avoid rotation of the valve and it shall not be greater than 4.15 mm.

The valve measured shall be fixed on the clamp (see [Fig. 10](#)) and which is held so as to avoid rotation of the valve.

The appliance adaptor shall be screwed until a torque of 12 Nm is obtained for a speed less than 1 nm/s.

The clamp shall then be loosened, and the valve-adaptor assembly removed from the clamp.

The dimension C ([Fig. 7](#)) shall be measured and the dimension X (see [5.7.2.2.8](#)) shall be calculated using the equation  $X = (A + B) - C$ .

X shall not be greater than 4.15 mm.

NOTE — This test is carried out on a valve that has not been fixed onto a cartridge consequently the valve centre boss will be pulled upwards in the appliance adaptor during the test, this is due to the abnormal tightening torque applied to

the valve during the test. This raising of the centre boss during the test is not taken into account.

**6.8 Transport, Fixing and Mobility Devices**

The verification of the requirement of [5.8](#) shall be carried out as follows:

- a) *Transport devices* — The appliance shall be lifted by hand and held for 15 s. If the instructions allow the transport of the appliance fitted on to its gas cartridge or gas cylinder the test shall be carried out, under these conditions, the gas cartridge or gas cylinder being full.
- b) *Fixing device* — The appliance shall be suspended for 15 s as specified in the instructions. If the instructions allow the operation of the appliance suspended, the test shall be carried out with the appliance fitted to a full gas cartridge or gas cylinder.
- c) *Mobility devices* — The verification of the requirements of [5.8](#) shall be carried out by visual examination and by moving the appliance.

**6.9 Taps**

The requirements of [5.9](#) shall be verified by visual examination, manipulation of the taps and tests in accordance with [Annex C](#).

**6.10 Control Handles**

The requirements of [5.10](#) shall be verified by visual examination, manipulation of the handles and reading the instructions.

**6.11 Injectors**

The requirements of [5.11](#) shall be verified by visual examination.

**6.12 Ignition Devices**

The requirements of [5.12](#) shall be verified by visual examination and during the ignition test [6.23](#).

**6.13 Flame Supervision Devices**

**6.13.1 General**

The Tests designed to verify the ignition and extinction delay defined in [5.3](#) shall be carried out under the following conditions:

ok

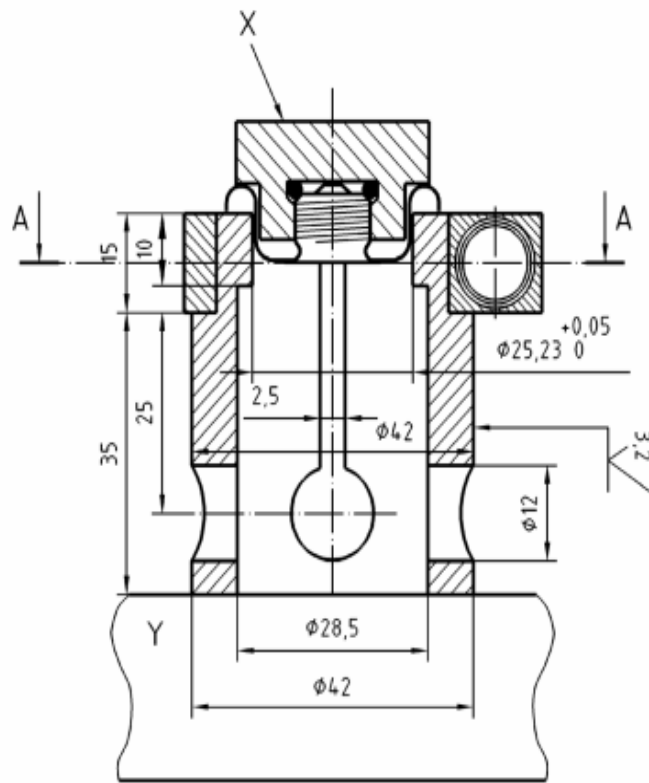

A-A

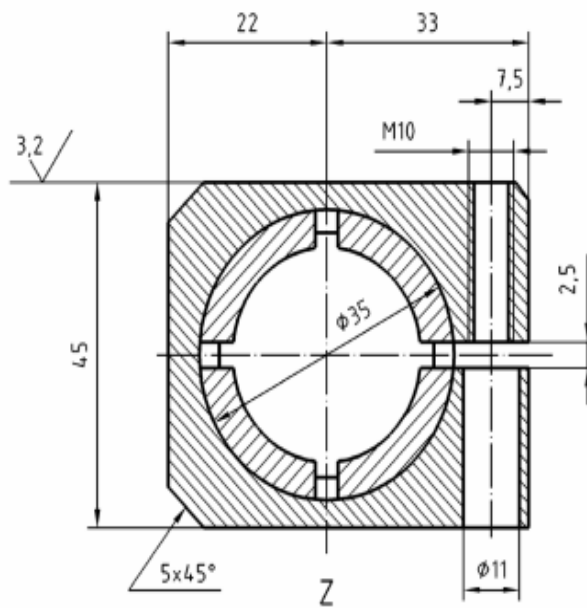

dimensions in millimetres.

Key

- X Appliance adaptor
- Y Base
- Z View on 'A'

FIG. 10 TEST CLAMP  
(see [6.7.2.2.3](#) and [6.7.2.2.4](#))

### 6.13.2 Ignition Delay Time

The appliance shall be supplied with gas at the pressure specified in [6.19.1](#).

The taps shall be in the full rate position or in the ignition position indicated in the instructions burners shall not be covered by vessels lid shall be open. At the start of the test the appliance shall be at the ambient temperature. The ignition delay time is the time between the ignition of gas at the pilot or at the burner and the moment when the flame supervision device allows the gas to supply the burner.

### 6.13.3 Extinction Delay Time

The appliance shall be supplied with gas at the pressure specified in [6.19.1](#).

The valves shall be in the full rate position the burner under test shall be covered with a vessel according to [6.1.4](#) filled with 2 kg of water or with a special vessel according to [6.5.1.2](#). Lid shall be closed if the instructions allow operation in this configuration. The test shall start after 15 min operation.

The extinction delay time is measured between the moment the supervised burner is voluntarily extinguished by shutting of the gas supply and the moment when, after immediate restoration of this supply, the flow of gas ceases through the action of the flame supervision device.

## 6.14 Burners and Radiant Elements

The requirements of [5.14](#) shall be verified by visual examination and manipulation of the appliance.

### 6.15 Grids

The requirements of [5.15](#) shall be verified by visual examination and dimensional checks. In order to verify the requirement of [5.15.2](#), the grid is covered with an evenly distributed load of 0.5 kg/mm<sup>2</sup> of useful area.

### 6.16 Turnspit

The requirements of [5.16](#) shall be verified by visual examination and dimensional checks. The stability of the turnspit shall be verified when a load of 0.5 kg/100 mm of useful length is applied.

## 6.17 Fireguards for Heating Appliances

### 6.17.1 Strength of Fireguards

#### 6.17.1.1 Probe test

The test shall start after 15 min operation with all Taps fully open the appliance being supplied with the gas at the pressure indicated in [6.19.1](#). The test probe cone described in [Fig. 10](#) is applied to the guard openings with a force of 5 N. The appliance is then allowed to cool to the ambient temperature of the test room. The appliance is placed so that the central section of the guard is horizontal. A flat disc 100 mm in diameter and 5 kg in mass is placed on the guard midway between the filing points for 1min and then removed.

ok

The appliance is then reheated as previously, and the cone described in [Fig. 11](#) is reapplied to the guard. The requirement of [\[5.17 a\) 1\]](#) shall be met.

#### 6.17.1.2 Pull test

A pull of 20 N shall be applied at any point and in any direction to the guard. The requirement of [\[5.17 a\) 2\]](#) shall be met.

#### 6.17.1.3 Appliance with glass panel

A direct blow having an impact energy of 0.5 N is applied to any point on the glass. The blow may be conveniently applied by means of the spring hammer described in [Fig. 14](#). The requirement of [\[5.17 a\) 3\]](#) shall be met.

### 6.17.2 Dimensions

The requirement of [\[5.17 b\)\]](#) shall be verified by visual examination and dimensional checks.

## 6.18 Locations and Compartments for Gas Cartridge or Gas Cylinder

The requirement of [5.18](#) shall be verified by visual examination, dimensional checks and manipulation of the appliance.

## 6.19 Verification of Heat Inputs

### 6.19.1 Test

The verification of the nominal heat input shall be carried out with the appliance operating under the following conditions:

- Butane burning appliances with Gas A at 1 bar;
- Butane/Propane mix burning appliances with Gas B at 3 bar; and
- Propane burning appliances with Gas C at 7 bar.



The test shall start when the burner under test has been operating for 15 min, with fully open taps, without a vessel on the burner and any lid open. Measurement shall be made under these operating conditions during the subsequent 15 min.

The tolerance on heat inputs indicated in [Fig. 8](#) shall be satisfied.

#### 6.19.2 Calculation of Heat Inputs

The nominal input  $D_N$  in kw is given by the

following expression:

$$D_N = 0.278 M_N \times H_S$$

where

$M_N$  = the nominal mass rate in kg/h, obtained under reference condition; and

$H_S$  = the gross calorific value in MJ/kg of the reference gas indicated in [6.1.1](#).

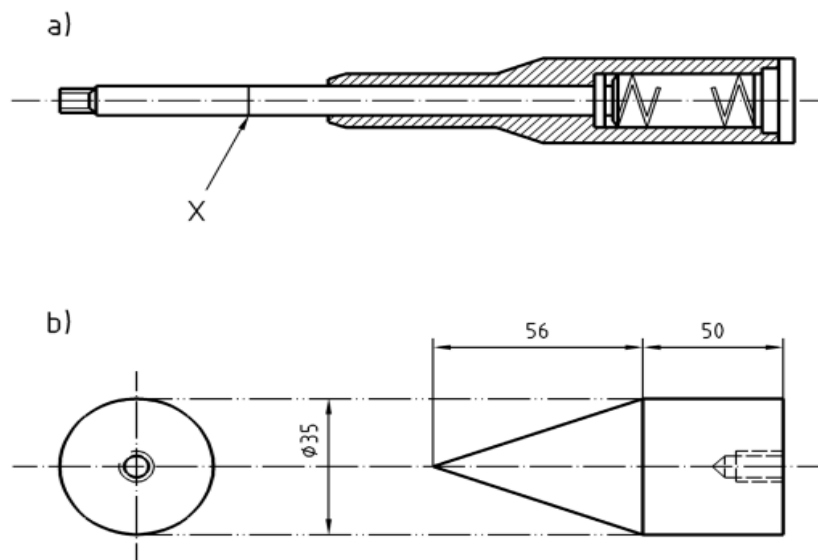

dimensions in millimeters.

Key

X Graduation 5 Newton

FIG. 11 TEST PROBE (see [6.17.1](#))

The mass rate corresponds to measurements and a flow of reference gas under reference conditions, that is the gas is assumed dry at 15 °C at a pressure of 1 013 mbar in practice, the values obtained during the tests do not correspond to these reference conditions, they shall then be corrected so as to bring them to the values which would have been obtained if these reference conditions had existed during the tests at the outlet of the injector.

The corrected mass rate is calculated using the following equation:

$$\frac{M_0}{M} = \sqrt{\frac{1013 + p}{p_a + p} \times \frac{273 + t_g}{288} \times \frac{d_r}{d}}$$

where

$M_0$  = the mass gas rate under reference conditions, expressed, in kg/h;

$M$  = the mass rate under test conditions, expressed, in kg/h;

$p_a$  = the atmospheric pressure, in mbar;

$p$  = the gas supply pressure, in mbar;

$t_g$  = the temperature of the gas at the measuring point, in °C;

$d$  = the density of dry gas relative to dry air; and

$d_r$  = the density of the dry reference gas relative to dry air.

These equations shall be used to calculate from the mass rate  $M$  measured during the test, the corresponding rate  $M_0$  that would have been obtained under reference conditions. The value  $M_0$  shall be compared with the value  $M_N$  calculated from the nominal calorific value using the formula at the beginning of this sub clause.

## 6.20 Resistance to Overheating

The burner under test shall be supplied under the following conditions:

- a) Butane burning appliances with Gas A at bar;
- b) Butane/Propane mix burning appliances with Gas A at 1 bar and gas C at 3 bar. Appliances have to be tested separately at both the pressure; and
- c) Propane burning appliances with Gas C at 7 bar.

NOTE — For appliances burning on commercial butane/propane mixture, they have to be tested both at 1 bar and 3 bar.

**6.20.1** The maximum heat input at which the gas can burn at the injector or inside the burner is established, using the following method:

- a) Stove burners are covered by vessels according to [6.1.4](#) filed with 2 kg of water or with a special vessel according to [6.5.1.2](#).
- b) Any appliance lids are open.
- c) The gas is lit at the injector and, in addition, if possible, at the burner head.
- d) If combustion cannot be maintained at the injector or inside the burner, the test continues:
  - 1) by reducing the pressure until combustion can be maintained, but stopping at the following minimum pressures:
    - i) Butane burning appliances with Gas A at 0.5 bar;
    - ii) Butane/Propane mix burning appliances with Gas A at 0.5 bar and Gas C at 3 bar; and
    - iii) Propane burning appliances with Gas C at 3 bar.
  - 2) then if necessary, by reducing the rate using the valves to the point where combustion can be maintained.

NOTE — For appliances burning on commercial butane/propane mixture, they have to be tested both at 0.5 bar and 3.0 bar.

- e) The test continues with the flame left in these conditions for 15 min, after this period the requirements of [5.20](#) shall be met.

## 6.21 Temperature of the Various Parts of the Appliance

### 6.21.1 Test Installation

The test installation consists of a horizontal panel and of a vertical panel. These 25 mm thick wooden panels are coated with black matt paint on the surface facing the appliance.

Thermocouples are incorporated in the panels at the centres of 10 cm squares, which penetrate the panel from the outside so that the junctions are situated 3 mm from the surface facing the appliance.

### 6.21.2 Test Method

#### 6.21.2.1 Floor standing and table standing appliances

The appliance rests on the support, the distance between the appliance and the vertical panel being the minimum distance indicated in the instructions.

The appliance operates for 1 h (possibly changing the gas cartridge or gas cylinder when it is empty) under the following conditions:

- a) A full gas cartridge or gas cylinder designed to be used with the appliance is fixed onto it, at the start of the test;
- b) All the taps are open in the full rate position;
- c) Stove burners are covered with a vessel according to [6.1.4](#) filed with 2 kg of water or with a special vessel according to [6.5.1.2](#);
- d) Any lid is closed if the instructions allow this mode of operation;
- e) Transport handles which fold downwards are placed in this position;
- f) Any grill is lit 15 min before the end of tests, at full rate, any grill-pan being in place; and
- g) Aeration adjusters shall be in the full open position.

Measure the rise in temperature reached during the test on the surfaces indicated in [5.21.1](#) and check that they do not exceed the limits fixed. The temperatures of glass or enameled surfaces shall be measured with a probe.

Measurements on accessible front panels and side

panels shall not be carried out on areas:

- 1) Which are not accessible to a 75 mm diameter test probe having a hemispherical end;
- 2) Which, on a stove, are less than 25 mm below, or are above the hob; and
- 3) Of small dimensions. Such as ventilation grilles or outlets for the products of combustion, fuels and gaskets whose width of accessible surface is less than 10 mm.

In addition, a measurement on a surface less than 1 cm<sup>2</sup> shall not be taken into account.

#### 6.21.2.2 Appliances intended to be held during use

The appliance is held 50 cm from the support in such a way that the axis of the flame is horizontal. It shall operate for 1 h under the conditions specified in [6.21.2.1](#).

Measure the maximum rise in temperature reached during the test on surfaces as indicated in [5.21.2](#) and check that they do not exceed the limits fixed.

### 6.22 Temperature of Panels (Floor, Wall or Ceiling)

#### 6.22.1 Floor Standing Appliances

The appliance shall be tested under the conditions defined in [6.21.2.1](#).

Measure the maximum rise in temperature reached during the test on panels (floor, wall) and check that they do not exceed the limits fixed in [5.22.1](#).

#### 6.22.2 Fixed Appliances

If the appliance is designed to be used hung from a ceiling, it shall be hung from a ceiling made of a panel similar to those described in [6.21.1](#), at the minimum distance indicated in the instructions.

If the appliance is designed to be hung by its handle from a wall, it shall be hung to a wall made of a panel similar to those described in [6.21.1](#), in accordance with the instructions. The appliance shall be operated for 1 h under the conditions defined in [6.21.2.1](#) (except for the positioning of the handle).

Measure the maximum rise in temperature reached during the test on the ceiling and/or the wall, depending on the case, and check that they do not exceed the limits fixed in [5.22.2](#).

### 6.23 Ignition, Cross Lighting and Flame Stability

#### 6.23.1 Test Conditions

Burners shall be supplied under the following conditions:

- a) Butane burning appliances with Gas A at 0.5 bar and Gas B at 2 bar;
- b) Butane/propane mix burning appliances with Gas A at 0.5 bar and Gas B at 5 bar; and
- c) Propane burning appliances with Gas B at 3 bar and Gas C at 9.5 bar.

NOTE — Appliances have to be tested separately at both the pressure.

#### 6.23.2 Test on Individual Burners, others Being Extinguished

6.23.2.1 The burner under test being at the ambient temperature of the test room, the tap/valve is opened and turned to the full rate position or to the ignition position indicated in the instructions. The burner is lit with a match or with the ignition device, if such exists.

When the ignition device supplies only one spark at a time, it is operated so as to obtain one spark a second.

The first operation shall take place when the gas reaches the burner ports.

The test shall be carried out firstly without a vessel on the burners, and then, for uncovered burners, with a vessel according to [6.1.4](#) filled with 2 kg of water or with a special vessel according to [6.5.1.2](#).

The test shall be carried out with any lid open, and then lid closed if the instructions allow this mode of operation.

For appliances fitted with a primary aeration adjuster the test shall be carried out with the air adjuster fully open.

Correct ignition and cross lighting of the burner shall be checked after 5 s operation. Flame stability shall be verified after 60 s operation.

6.23.2.2 After examination of the flame, check that there is neither extinction nor light back when:

- a) The appliance is supplied at minimum pressure, with the tap fully open (fully open aeration adjuster); and
- b) The appliance is supplied at maximum pressure, the tap turned from the full rate position to that of the reduced rate in

approximately 1 s (aeration adjuster open then closed). For this test, the reduced rate for needle type valves is defined as being equal to half the nominal rate.

**6.23.2.3** After checking that there is neither extinction nor light back, leave the burner to operate for 5 min, then switch it off and carry out a re-ignition test under the same test conditions as those for ignition. Check that ignition and cross lighting take place within 5 s and that flames are stable after 60 s operation.

### 6.23.3 Test on Individual Burners, others Being Lit

The tests described in [6.23.2](#) shall be repeated on each burner whilst the other burners operate without vessels and with their valves fully open.

In addition, check that cross lighting between burners within a common enclosure which are not protected by flames supervision devices is smooth. The checks are made when:

- a) the valves of the new burner to be lit are in the full rate position (or in the ignition position specified in the instructions);
- b) the valves of burner(s) already lit are in the full rate position or in the ignition position(s) specified in the instructions; and
- c) the burners already lit have been operating for 60s.

## 6.24 Resistance to Draught

**6.24.1** The tap corresponding to the burner under test shall be in the full rate position and the appliance shall be supplied under the following conditions:

- a) Butane burning appliances with Gas A at 0.5 bar and Gas B at 2 bar;
- b) Butane/Propane mix burning appliances with Gas A at 0.5 bar and Gas B at 5 bar; and
- c) Propane burning appliances with Gas B at 3 bar and Gas C 9.5 bar.

NOTE — Appliances have to be tested separately at both the pressure.

Each burner is tested individually, the other burners being extinguished. Stove burners are covered by a vessel according to [6.1.4](#) or with a special vessel according to [6.5.1.2](#). Appliance lids are open. Aeration adjusters shall be in the fully open position.

Hotplate burners are covered by a 180 mm diameter vessel. Appliance each burner is tested individually the other burners being extinguished. Lids are open aeration adjusters shall be in the fully open position.

After 15 min operation, a substantially laminar draught of 3 m/s is directed horizontally towards the appliance at the burner height. The draught is interrupted so as to produce 5 gusts of 10 s with 10 s intervals between them. Tests are repeated for successive rotations of 45° in the horizontal plane round the appliance.

In all configurations the requirements of [5.24](#) shall be met.

**6.24.2** For appliances intended to be held (for example, blow lamps) or which incorporate an aeration adjuster which is adjustable by the user the draught shall be perpendicular to the flame axis. In addition, the test pressures given in [6.24.1](#) are replaced by the following:

- a) Butane burning appliances with Gas A at 1 bar and Gas B at 2 bar;
- b) Butane/Propane mix burning appliances with Gas B at 3 bar and 5 bar; and
- c) Propane burning appliances with Gas B at 7 bar and Gas C at 9.5 bar.

NOTE — Appliances have to be tested separately at both the pressure.

In all the configurations the requirement of [5.24](#) shall be met.

## 6.25 Resistance to Liquid Spillage

Stove burners are operated, with taps fully opened under the following conditions:

- a) Butane burning appliances with Gas A at 1 bar;
- b) Butane/Propane mix burning appliances with Gas B at 3 bar; and
- c) Propane burning appliances with Gas C at 7 bar.

They are used to bring to and keep boiling a vessel according to [6.1.4](#), not covered by a lid, filled with water to a height of 10 mm from the top or with a special vessel according to [6.5.1.2](#). The test continues until there is no spillage. The requirement of [5.25](#) shall be met. Partial extinction of the burners is permitted provided that there is automatic re-ignition.

## 6.26 Combustion

### 6.26.1 General Conditions

The tap corresponding to the burner under test shall be in the full rate position and the appliance shall be supplied under the following conditions:

- a) Butane burning appliances with Gas A at 0.5 bar and Gas B at 2 bar;

- b) Butane/Propane mix burning appliances with Gas A at 0.5 bar and Gas B at 5 bar; and
- c) Propane burning appliances with Gas B at 3 bar and Gas C at 9.5 bar.

NOTE — Appliances have to be tested separately at both the pressure.

For each of these supply conditions, the tests shall be carried out with the burners operating individually, and then repeated with the other burners operating with their Taps fully open.

The tests shall be carried out with any lid open or closed if the instructions allow this mode of operation. The tests shall be carried out with the aeration adjuster fully open for appliances fitted with a user adjustable aeration adjuster.

The products of combustion are sampled 15 min after the start of the test.

The quantity of CO<sub>2</sub> in the sample shall preferably be greater than 1 percent (V/V).  **smallcase (v/v)**

The use of a restrictor is permitted so as to obtain such a quantity of CO<sub>2</sub>. If it is impossible to obtain a quantity of 1 percent CO<sub>2</sub> a concentration lower than 1 percent may be accepted, but the laboratory shall ensure the reproducibility of the sample taken.

The requirements in [5.26](#) shall be met.

If the appliance is made of parts to be placed by the user that can be put in a wrong position which is likely to impair its safety and combustion test is repeated with those parts in their worst position.

### 6.26.2 Stove Burners

Stove burners under test are covered by a vessel

according to [6.1.4](#) filed with 2 kg of water or with a special vessel according to [6.5.1.2](#). No vessel is placed on contact grills or covered burners. When testing a single burner, the vessel is covered by a device complying with [Fig. 12](#). When testing burners simultaneously, the appliance is covered with one of the devices complying with [Fig. 13](#), chosen according to the shape of the stove in such a way that the quality of combustion is not affected.

### 6.26.3 Analysis of the Products of Combustion

For all the tests, carbon monoxide is measured with a selective method allowing a concentration of 0.005 percent by volume to be detected accurately.

The quantity of CO in the air and water vapour free products (neutral combustion) is given by the following equation:

$$\% (\text{CO})_N = \% (\text{CO}_2)_N \times (\text{CO})_M / (\text{CO}_2)_M$$

where

$\% (\text{CO})_N$  = percentage of CO in the dry, air free products of combustion

$\% (\text{CO}_2)_N$  = percentage of CO<sub>2</sub> calculated for the dry, air free products of combustion of the gas used (natural combustion)

$(\text{CO})_M$  and  $(\text{CO}_2)_M$  are the carbon monoxide and carbon dioxide concentration measured in the sample during the combustion test, both expressed in the same units.

The values in percent of  $(\text{CO}_2)_N$  (products of neutral combustion) are 14.0 for Gas A and 13.7 for Gas B and C.

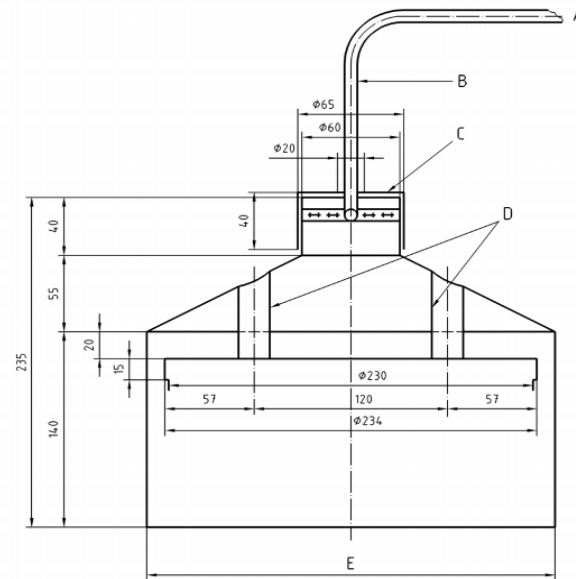

**Key**

To analyser  
Copper tube 8/1

NOTE — By convention 8/1 denotes diameter 8 thickness 1.

Restrictor  
Steel tube 22/1  
Diameter internal 258

All dimensions in millimetres.

FIG.12 VERIFICATION OF THE COMBUSTION OF INDIVIDUAL STOVE BURNERS – SAMPLING DEVICE (see 6.26.2)

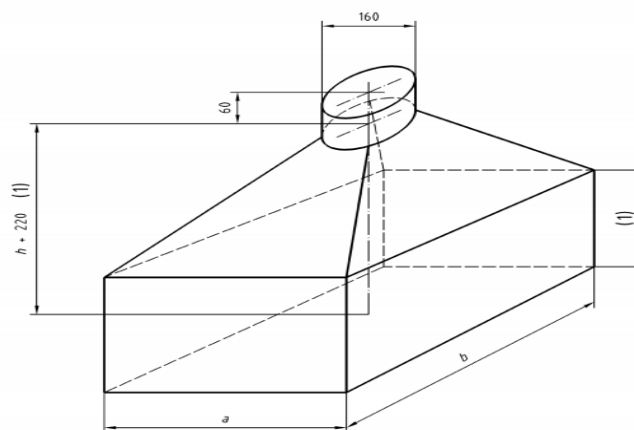

a	500	580	680	710	630	790
b	600	700	680	780	1140	1000

As a guide the six devices whose dimensions are given above cover most cases met.

(1)  $h > 320$  allows the opening of lids or enough space between the device and covered burners

All dimensions in millimetres.

FIG. 13 VERIFICATION OF THE COMBUSTION OF ALL BURNERS-SAMPLING DEVICE (see 6.26.2)

Carbon dioxide CO<sub>2</sub> is measured with a method allowing measurement with a relative error not exceeding 6 percent.

### 6.27 Accumulation of Un-Burnt Gases

The requirement of [5.27](#) is checked by visual examination.

### 6.28 Safety at High Temperature

The appliance, connected to a full gas cartridge or gas cylinder, is placed in a properly ventilated room whose temperature is maintained at  $(35 \pm 3)$  °C until it reaches thermal equilibrium. It is then lit with all tap in the full-on position.

Stove burners are covered by a steel disc of 2 mm in thickness. The diameter of the disk is at least 180 mm. If the diameter of the pan support is more than 180 mm, then the disk diameter shall be the closest to the largest dimension of the pan support as defined in [Table B.1](#).

NOTE — The highest dimension of the pan support is the diameter of the circle centered on the burner circumscribed with the pan support (see examples given in [Fig. 14](#)).

(For the case described in [6.5.1.2](#), this disc is replaced by the vessel specific to the appliance, three quarters full of water, if this vessel has an external diameter less than 180 mm).

For lighting appliances, mantles are pierced with

5 mm diameter hole. This hole shall be placed so that the flame coming from it is directed towards parts which could be damaged or cause maximum overheating. Any lid is closed if the instructions allow this mode of operation.

A pressure recording device is connected either to the gas cartridge or gas cylinder or to the appliance gas circuit situated between the gas inlet and the gas closing point of the tap. The connection circuit shall not influence the temperature of and the pressure in the gas cartridge and the gas circuit of the appliance.

The appliance is operating at full rate for 30 min and then shut-off. The pressure inside the gas cartridge or gas cylinder is measured until it drops to ensure that it does not exceed the pressure of the gas contained at 50 °C.

NOTE — The pressure of gas at 50 °C inside the gas cartridge or gas cylinder is measured before the test, when the cartridge or gas cylinder is full, for example by maintaining it in a bath of hot water until thermal equilibrium is reached at 50 °C.

Allow the appliance to cool and check for deterioration of the appliance and cartridge, then fix a new gas cartridge or gas cylinder and light the burners. The appliance is then subjected to the soundness test described in [6.6.1](#).

The requirement of [5.28](#) shall be met.

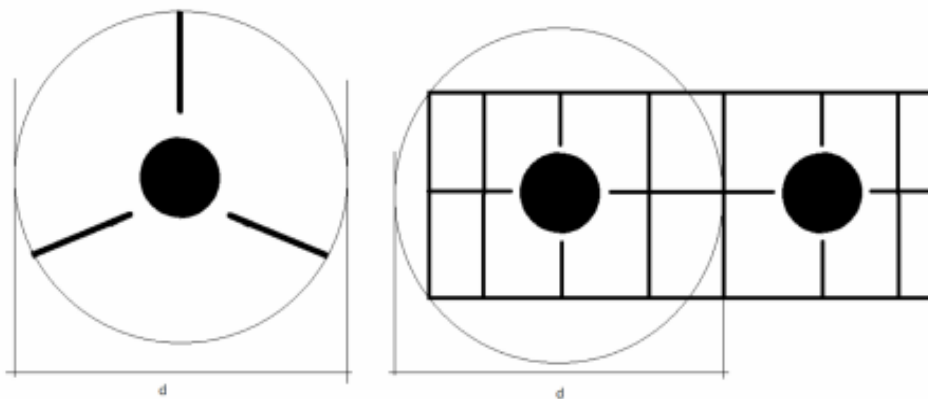

Key

d = Diameter of circle centered on the burner circumscribed with the pan support

FIG. 14 EXAMPLE OF DIAMETER TO BE CONSIDERED FOR TEST VESSEL DETERMINATION

## 6.29 Shooting — Condensation

The requirements of [5.29](#) shall be checked by visual examination.

## 6.30 Rational use of Energy

### 6.30.1 Uncovered Stove Burners

Each burner is supplied with the gas at the pressures indicated in [6.19.1](#), the tap being fully open. Aluminium vessels with matt bases, smooth sides, with no handle and in accordance with the characteristics of [Annex B](#) are used. The vessels are covered by their lids.

NOTE — For appliances with special vessels (see [6.5.1.2](#)), the test is carried out with the special vessel filled with water to within 10 mm of the top for this test.

Depending on the nominal heat input of the burner under test, the vessel diameter to be used and the quantity of water which it contains are given in the table below, the heat input may need to be adjusted so as to take into account the information given in this [Table 3](#).

The water temperature at the beginning of the test shall be  $(20 \pm 1) ^\circ\text{C}$  and the temperature when the burner is extinguished  $(90 \pm 1) ^\circ\text{C}$ .

The maximum temperature after the extinction of the burner shall be observed (final temperature).

A measuring device is placed in the centre of the volume of water, and the temperature is measured using a sensor whose measurement uncertainty is less than  $0.5 ^\circ\text{C}$ .

The burner, covered by a 220 mm diameter vessel containing 3.7 kg of water, operates for ten minutes at nominal rate. The 220 mm vessel is removed and immediately the vessel used for the efficacy test is placed on the burner. The measurement of gas consumption begins then and it ends after the burner's extinction, the vessel remaining in place.

The efficacy is calculated from the equation:

where

$\eta$  = is the efficiency in percentage

$M_e$  = is the water equivalent of the vessel filled as indicated in the table above;

The mass  $M_e$  is made up as follows:

$$M_e = M' + 0.213 m \quad \text{correct as 0.213}$$

where

$M'$  = is the mass of water put into the vessel.

$m$  = is the mass of aluminium corresponding to the test vessel covered by its lid (the mass  $m$  to be taken into account shall be the mass measured).

**Table 3 Vessel Diameter and Mass of Water Relative to the Burner Heat Input**

(Clause [6.30.1](#))

SI No.	Nominal Heat Input of the Burner (kW)	Internal Diameter of the Vessel (mm)	Mass of Water $M'$ to be Used (kg)
(1)	(2)	(3)	(4)
i)	Between 1.16 and 1.64	220	3.7
ii)	Between 1.65 and 1.98	240	4.8
iii)	Between 1.99 and 2.36	260 <sup>a</sup>	6.1
iv)	Between 2.37 and 4.2	260 <sup>a</sup>	6.1

With the burner heat input adjusted to 2,36 kW

<sup>a</sup> If the 260 mm diameter vessel does not allow the test to be carried out under normal conditions of use of the appliance the test shall be carried out with a 240 mm diameter vessel and the heat input of the burner shall be adjusted to 1.98 kW.



All masses are expressed in kilograms:

- $t_1$  = is the water temperature in °C at the start of the test;
- $t_2$  = is the water temperature in °C after extinction;
- $M$  = is the mass of gas burnt in kg (under the reference conditions of the gross calorific value);

$H_8$  is the gross calorific value of gas in MJ/kg  $C_p = 4.186 \times 10^{-3}$  MJ/kg/°C.

The requirements defined in [5.30.1.1](#) shall be met.

### 6.30.2 Covered Burners

Each burner is supplied with gas at the pressure indicated in [6.19.1](#), the tap being fully open.

Efficacies, from the cold condition and from the hot condition, with any plates and rings being in place, are measured under the following conditions:

- The vessel corresponding to the burner under test, *see* Table 3, in the most suitable position is placed on the stove.
- The smallest numbers of vessels chosen from [Annex B](#) with the largest possible diameter are placed on the remaining surface of the plate.

The temperature is measured in the same way as for an uncovered burner: the start temperature of the water being  $20 \text{ °C} \pm 1 \text{ °C}$ , the final temperature is for each vessel the highest temperature observed after the burner extinction, this being carried out once the temperature of the water in any of the vessels reaches  $90 \text{ °C} \pm 1 \text{ °C}$ . The efficacy is the ratio between the sum of the quantities of heat absorbed by vessels and the water that they contain, and the quantity of heat released at the burner. A second series of tests shall be carried out from the hot condition. The stove is said to be hot when the water in the main vessel, used for the efficacy test, is brought to the boil, this vessel being used alone. The requirements of [5.30.1.2](#) shall be met.

### 6.31 Durability of the Marking

The markings are manually rubbed during 15 s with a water-soaked rag and then again during 15 s with a water gasoline/petrol soaked rag.

### 6.32 Strength and Endurance Test

Each component of the appliance linked to the safety of the appliance (for example, regulator, quick

connection valve) is submitted to 2 000 cycles of normal operation corresponding to its function. The cycles are carried out at ambient temperature the appliance being supplied with air at pressures given in [6.19.1](#).

## 7 MARKING

### 7.1 Appliance Marking

Any label shall not block the ventilation openings of the cylinder or cartridge compartment. The appliance shall carry the following information, in a visible (*see* [8.1](#) for readability) and durable fashion, in the official language(s) of the country in which the appliance is to be sold:

- Name of the manufacturer or his identifying symbol;
- Postal address of the manufacturer. If not possible, on the packaging or in a document accompanying the appliance;
- Appliance name;
- Type of gas (butane; butane-propane mixture; propane);
- Appliance 'category: direct pressure';
- Brand and type of the gas cartridge or gas cylinder (s) intended to be used with the appliance, in the form:

#### NOTES

1 This appliance shall only be used with the gas cylinder confirming to IS 7142, IS 12586, IS 3196 (Part 1) as the case may be.

2 This appliance shall only be used with the non-refillable gas cartridge.

- Text 'Use outdoors only' for heating appliances (space heaters, gas iron) and barbecues or 'Only use in well ventilated areas' for other types of appliances. For heating appliances, the text 'Use outdoors only' shall be shown on the appliance using letters at least 3 mm high. Text 'Read the instructions before using the appliance'
- text 'Read the instructions before using the appliance';
- For heating appliances and barbecues, the text '**CAUTION**: accessible parts may be very hot, Keep young children away from the appliance'; and
- For appliances designed for use with pierceable cartridges, diagrams showing the correct sequence for the fitting of the cartridge.

This information may be given on durable labels fixed onto the appliance.

ok

## 7.2 Packaging Marking

The packaging of the appliance shall carry the information in [7.1 c) to g)] in the official language(s) of the country in which the appliance is to be sold.

## 7.3 BIS Certification Marking

The product may also be marked with Standard Mark.

**7.3.1** The product(s) conforming to the requirements of this standard may be certified as per the conformity assessment schemes under the provisions of the *Bureau of Indian Standards Act, 2016* and the Rules and Regulations framed thereunder, and the products may be marked with the Standard Mark.

# 8 INSTRUCTIONS FOR USE, MAINTENANCE AND ASSEMBLY

## 8.1 General

Instructions for use, maintenance (storage, cleaning, checking before use etc) and assembly intended for the user shall be supplied with each appliance and shall give all necessary information to use the appliance safely and sensibly. Readability is determined by the combination of font size (the minimum letter size of 1.2 mm height can be used as a reference), letter spacing, spacing between lines, colour, width-height ratio of the letters and significant contrast between the print and the background.

The instructions shall give at least the information listed in 8.2, in the language(s) required by the member states in which the appliance is to be sold.

## 8.2 Instruction Contents

### 8.2.1 Important

Read these instructions for use carefully so as to familiarize yourself with the appliance before connecting it to its gas cartridge or gas cylinder. Keep these instructions for future reference.

### 8.2.2 An Introduction Containing the Following Information

- a) Name of the manufacturer and his identifying symbol;
- b) Appliance name;
- c) Type of gas, the appliance cartridge and the type of gas cartridge(s) or gas cylinder (s)

to be used stating: This appliance shall only be used with the XYZ (gas); This sentence shall be followed by ‘It may be hazardous to attempt to fit other types of gas cartridge or gas cylinder’;

- d) Injector marking (if it is removable);
- e) Nominal rate in g/h and kW (Hs ); and
- f) Statement: ‘Use outdoors only’ or ‘Use only in a well-ventilated area’, depending on the use (see 7.1 f).

### 8.2.3 The Following Safety Information

- a) Where applicable the statement: ‘Check those seals (between the appliance and the gas cartridge or gas cylinder)’ are in place and in good condition before connecting to the gas cartridge or gas cylinder;
- b) Drawing showing the position of these seals (if applicable);
- c) Statement ‘Do not use the appliance if it has damaged or worn seals’ ‘Do not use an appliance which is leaking, damaged or which does not operate properly’;
- d) Statement requiring that appliances, other than those solely for outdoor use, be used in a well-ventilated location in accordance with national requirements:
  - 1) or the supply of combustion air, and
  - 2) to avoid the dangerous building up of un-burnt gases for appliances not fitted with a flame supervision device.
- e) Statement that the appliance shall be operated on a horizontal surface, unless it is not intended to operate resting on a surface;
- f) Statement that the appliance shall be used away from flammable materials and information on minimum distances from adjacent surfaces (wall, ceiling);
- g) Statement that gas cartridge or gas cylinder shall be changed in a well-ventilated location, preferably outside, away from any sources of ignition, such as naked flames, pilots, electric files and away from other people; and
- h) Statement that ‘If there is a leak on your appliance (smell of gas), take it outside immediately into a well-ventilated flame free location where the leak may be detected and stopped. If you wish to check for leaks on your appliance, do it outside. Do not try to detect leaks using a flame, use soapy water’.

**8.2.4** *The Following Information for Use*

- a) Advise on how to use the appliance when it is hot (for example, the use of gloves for barbecues) and for heating appliances and barbecues, the statement:
- CAUTION:** accessible parts may become very hot. Keep young children away from the appliance’.
- b) Advise on how to store the appliance when it is not in use;
- c) How to light the appliance;
- d) How to adjust the rate and the meaning of the symbols used for the various adjustment positions (see [5.10.2](#)); and
- e) Information on the phenomenon of flaring which may occur during the warmup period or if the appliance is moved. The indication on the duration of any warmup period shall be specified.

NOTE — For appliances incorporating a flexible hose, the text: ‘Avoid twisting of the flexible hose’.

**8.2.5** *The Following Information for Assembly*

- a) if the appliance is not fully factory assembled, assembly by the user shall be precisely described (with drawings) so as to avoid any dangerous assembly by the user;
- b) correct way of connecting the appliance to a gas cartridge or gas cylinder;
- c) how to check that the appliance is connected to the gas cartridge or gas cylinder in a sound fashion;
- d) how to detect leaks (see [8.2.3 h](#)); and

- e) how to fix any stabilizer supplied with the appliance.

**8.2.6** *The Following Information for Changing the Gas Cartridge or Gas Cylinder*

- a) For appliances with pierceable cartridges, check that the cartridge is empty before changing it (shake to hear the noise made by the liquid);
- b) Check that burners are extinguished before disconnecting the gas cartridge or gas cylinder;
- c) Full details on how to disconnect the gas cartridge or gas cylinder;
- d) Check the seals before connecting a new gas cartridge or gas cylinder to the appliance;
- e) Change the gas cartridge or gas cylinder outside and away from people; and
- f) Information for the safe connection of the gas cartridge or gas cylinder.

**8.2.7** *The Following Information on Routine Maintenance of the Appliance*

- a) Cleaning the injector (if necessary); and
- b) Identification of seals replaceable by the user and how to replace them, and identification of non-metallic radiant elements (see [5.3](#)).

**8.2.8** *Information for General Maintenance and Repairs*

- a) Text ‘Do not modify the appliance’; and
- b) How to send the appliance back to the manufacturer or to a repair centre.

## ANNEX A

(Clause 2)

## LIST OF REFERRED STANDARDS

<i>IS No.</i>	<i>Title</i>	<i>IS No.</i>	<i>Title</i>
IS 617 : 1994	Cast aluminum and its alloys — Ingots and castings for general engineering purposes — Specification ( <i>third revision</i> )	IS 8737 : 2017	Valve fittings for use with liquefied petroleum gas (LPG) cylinders for more than 5 litre water capacity — Specification ( <i>second revision</i> )
IS 3196 (Part 1) : 2013	Welded low carbon steel cylinders exceeding 5 litre water capacity for low pressure liquefiable gases: Part 1 Cylinders for liquefied petroleum gases (LPG) — Specification ( <i>sixth revision</i> )	IS 9573 (Part 2) : 2017	Rubber hose for liquefied petroleum gas (LPG) — Specification : Part 2 Domestic and commercial application ( <i>fourth revision</i> )
IS 4576 : 2021	Liquefied petroleum gases — Specification ( <i>fourth revision</i> )	IS 12586 : 2021	Brazed low carbon steel gas cylinders not exceeding 13 litre water capacity — Specification ( <i>first revision</i> )
IS 6480 : 2023	Terms relating to domestic and commercial gas burning appliances — Glossary ( <i>second revision</i> )	IS 17891 (Part 1) : 2023	Fluid power systems O-rings Inside diameters cross-sections tolerances and designation codes
IS 6912 : 2005	Copper and copper alloys forging stock and forging — Specification ( <i>second revision</i> )	(Part 2) : 2023	Housing dimensions for general applications
IS 7142 : 1995	Welded low carbon steel cylinders for low pressure liquefiable gases not exceeding 5 litre water capacity — Specification ( <i>first revision</i> )	(Part 3) : 2023	Quality acceptance criteria
		(Part 4) : 2023	Anti-extrusion rings back-up rings
		(Part 5) : 2023	Specification of elastomeric materials for industrial applications

To access Indian Standards click on the link below:

[https://www.services.bis.gov.in/php/BIS\\_2.0/bisconnect/knowyourstandards/Indian\\_standards/isdetails](https://www.services.bis.gov.in/php/BIS_2.0/bisconnect/knowyourstandards/Indian_standards/isdetails)

**ANNEX B**

(Clause 6.5.2.3, 6.30.1 and 6.30.2)

(Normative)

**CHARACTERISTICS OF TEST VESSELS**

The pans required for testing stoves shall comply with [Fig. B-1](#) and their dimensions shall comply with [Table B-1](#).

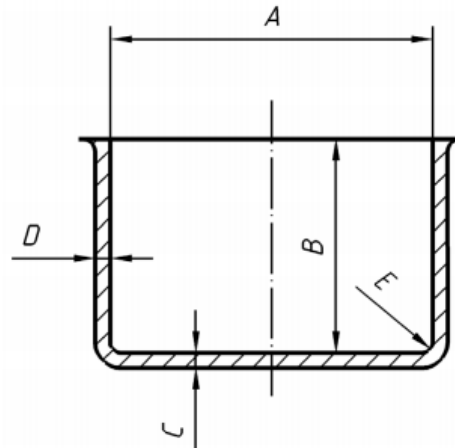

FIG. B-1 CHARACTERISTICS OF TEST VESSELS

**Table B-1 Characteristics of Pans Necessary for Testing**

SI No. (1)	(2)	(3)	Dimensions (4)												Tolerance (5)
			12	14	16	18	20	22	24	26	28	30	32	34	
i)															
ii)	A	m m	120	140	160	180	200	220	240	260	280	300		340	±1 percent
iii)	H	m m	90	100	110	120	130	140	150	160	170	180	190	200	±1 percent
iv)	C min	m m	1.6	1.6	1.8	2	2	2	2	2.5	2,5	2,5	2,5	2,5	
v)	D min	m m	1,5	1,5	1,5	1,5	1,5	1,5	1.5	1.8	1.8	1.8	1.8	1.8	
vi)	E	m m	2	2	2,5	2,5	2,5	3	3,5	3,5	3,5	3,5	3,5	4	+0.50
vii)	Base area	C m <sup>2</sup>	113	154	201	254	314	380	452	531	615	707	804	907	
viii)	Mass	G	220	270	340	440	540	680	800	965	1 130	1 350	1 520	1 800	± 5 percent
ix)	Mass of lid <sup>a</sup>	g	58	70	86	105	125	149	117	208	290	323	360	402	

<sup>a</sup> Mass without handles, calculated for aluminium lids (density 2 700 kg/m<sup>3</sup>) give for information

ANNEX C

(Clause 5.9.2 and 6.9)

TEST ON NEEDLE VALVES

**C-1 RESISTANCE TO TEMPERATURE**

The soundness of 3 valves is checked with air at the following pressures:

appliances burning butane	: 0.5 bar and 8 bar
appliances burning butane-propane mix	: 0.5 bar and 12 bar
appliances burning propane	: 0.5 bar and 18 bar

Soundness is checked under the following conditions:

- on delivery at ambient temperature.
- Raise the temperature of the Valves to  $40\text{ }^{\circ}\text{C} \pm 5\text{ }^{\circ}\text{C}$  and maintain for 120 h then bring back to ambient and check for soundness.
- Cool the Valves to  $-20\text{ }^{\circ}\text{C} \pm 5\text{ }^{\circ}\text{C}$  for 24 h then bring back to Ambient and check for soundness.

For each test the leak shall be less than  $4\text{ N mm}^3/\text{s}$  valve closed and valve open (injector sealed).

**C-2 ENDURANCE**

The soundness of 2 valves is checked using air at

ambient temperature after an endurance test of 2 000 cycles at the pressures given in **C-1**.

Test method:

- The life test is carried out at ambient temperature with air flowing through the valve at a pressure of 0.5 bar;
- A cycle comprises the rotation from the closed position to the fully open position (without applying force to the top) and, without stopping, reverse the rotation to the closed position with the application of a torque of 0.3 Nm;
- The frequency shall be  $6 \pm 2$  cycles/min; and
- At the end of 2 000 cycles, the valve is closed with a torque of 0.5 Nm and soundness is checked with air at the pressures given in **C-1**. It is checked at the same pressures, with the valve open (injector sealed).

The leak shall be less than  $4\text{ N mm}^3/\text{s}$ .

**ANNEX D**

*(Informative)*

**EXAMPLES OF AUTHORIZED SOLUTIONS**

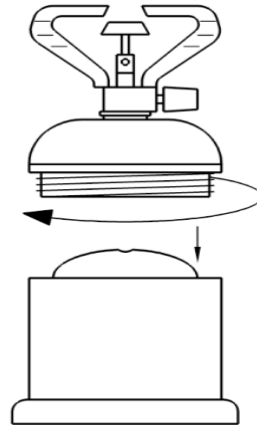

- a) Pierceable device is fixed with the top housing.
- b) The cartridge is held by a housing which is made in two pieces screwed together: small upper part, large bottom.

FIG. D-1 AUTHORIZED SOLUTIONS – EXAMPLE 1



*Key*

1 Not allowed

FIG. D-2 AUTHORIZED SOLUTION – EXAMPLE 2

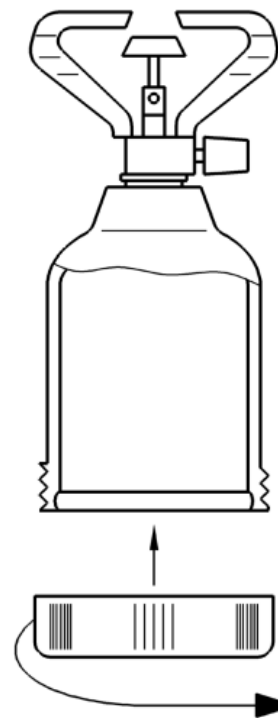
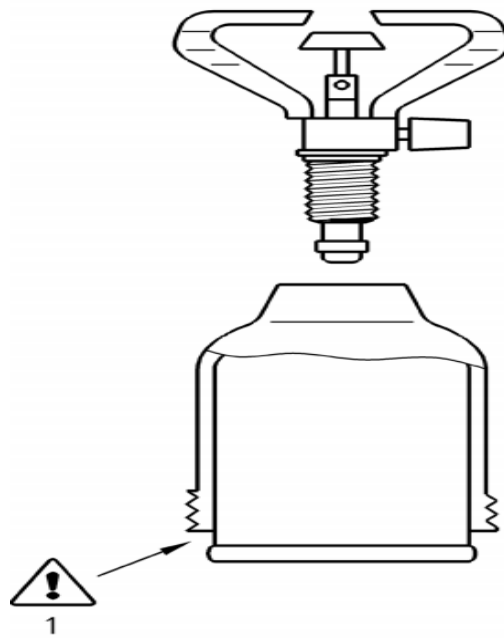

FIG. D-3 AUTHORIZED SOLUTIONS – EXAMPLE 3



- a) Pierceable device is fixed with the housing;
- b) The cartridge should not extend beyond the lower edge of the housing (*see* warning 1 of [Fig. D-2](#) which is not allowed); and
- c) The cartridge is held by a large housing which has a small removable part (screw type system) at the bottom to close the housing (*see* [Fig. D-5](#)).

Key

1 Not allowed

FIG. D-4 AUTHORIZED SOLUTION — EXAMPLE 4

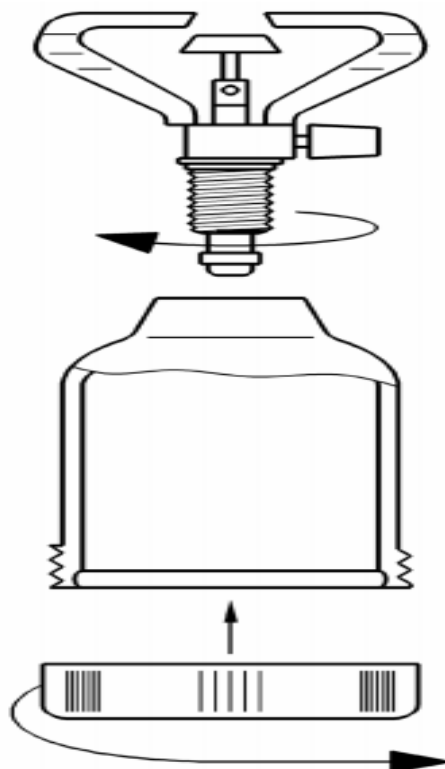



- a) Pierceable device is removable form the housing
- b) The cartridge should not extend beyond the lower edge of the housing (*see* warning 1 of [Fig. D-4](#) which is not allowed).
- c) The cartridge is held by a large housing which has a removable part (screw type system) at the bottom to close the housing (*see* [Fig. D-5](#)).

FIG. D-5 AUTHORIZED SOLUTIONS – EXAMPLE 5

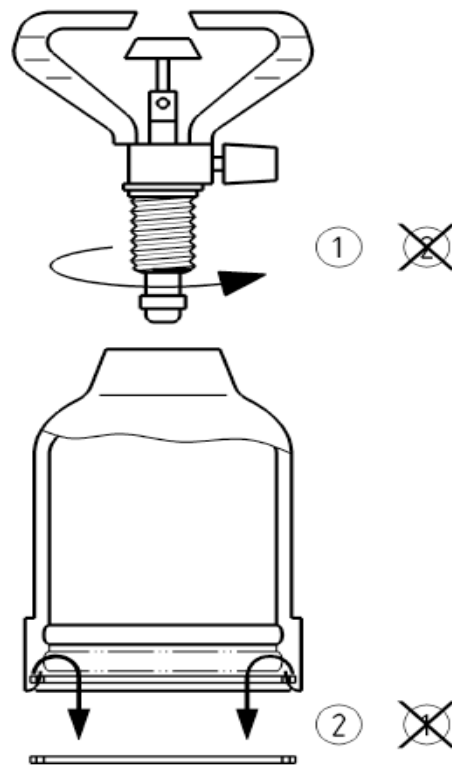
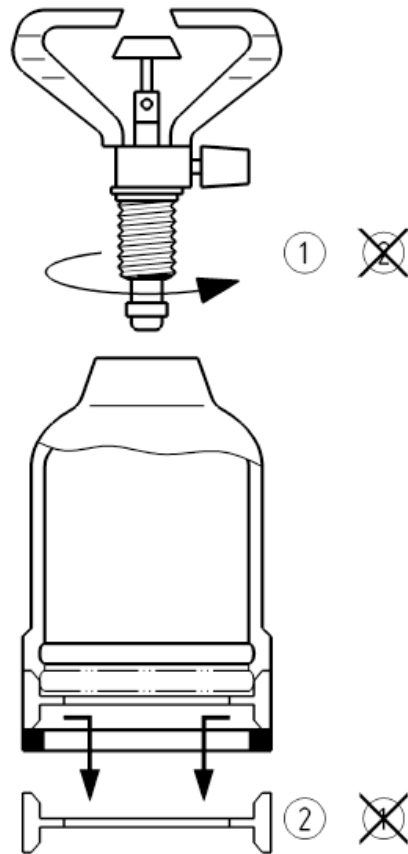

FIG. D-6 AUTHORIZED SOLUTION - EXAMPLE 6



- a) Pierceable device is held by a large housing
- b) The Cartridge is held by a large housing which has a movable part 2 (see Fig. [D-6](#) or [D-7](#)) which cannot be removed unless the piercing device 1 (see Fig. [D-6](#) or [D-7](#)) is removed before.

FIG. D-7 AUTHORIZED SOLUTION – EXAMPLE 7

## ANNEX E

(Foreword)

## COMMITTEE COMPOSITION

Domestic and Commercial Gas Burning Appliances Sectional Committee, MED 23

<i>Organization</i>	<i>Representative(s)</i>
L.P.G. Equipment Research Centre, Bengaluru	SHRI T. D. SABU ( <b>Chairperson</b> )
Bharat Petroleum Corporation Limited, Mumbai	SHRI HARI BABU BANOTH SHRI MOHIT RANE ( <i>Alternate</i> )
BSH Household Appliances Manufacturing Private Limited, Chennai	SHRI VIJAY KUMAR LOGANATHAN
Bureau of Energy Efficiency, New Delhi	MS PRAVATANALINI SMAL SHRI KAMRAN SHAIKH ( <i>Alternate I</i> ) SHRI MUKHE K. SAI SATVIK ( <i>Alternate II</i> )
Butterfly Gandhimathi Appliances Private Limited, Chennai	SHRI K. SHANMUGAVELU SHRI A. BHASKAR ( <i>Alternate</i> )
CSIR - Indian Institute of Petroleum, Dehradun	SHRI PANKAJ KUMAR ARYA
Gorani Industries Limited, Indore	SHRI NAKUL GORANI
Goyal Engineers Private Limited, New Delhi	SHRI AJAY GOYAL SHRI NEERAJ GOYAL ( <i>Alternate</i> )
Hindustan Petroleum Corporation Limited, Mumbai	SHRI RAKESH G. KHADE SHRI DINESH PANGTEY ( <i>Alternate I</i> ) SHRI SUBRAMANI SIVA ( <i>Alternate II</i> )
Ideal Engineers Hyderabad Private limited, Hyderabad	SHRI SATISH KABRA
Indian Oil Corporation (R and D Centre), Faridabad	SHRI ASHUTOSH TIWARI
Indraprastha Gas Limited, New Delhi	SHRI PAWAN KUMAR SHRI ANUPE FRANCIS ( <i>Alternate</i> )
L.P.G. Equipment Research Centre, Bengaluru	SHRI P. R. DEODHAR ( <i>Alternate</i> )
Mahanagar Gas Limited, Mumbai	SHRI BHATTIPROLU RAM SUDHEER MS NEHA KHARYA
Racold Thermo Limited, Pune	SHRI ABHIJIT BANSHELIKAR
Rama Domestic Appliances, New Delhi	SHRI AMARJEET SINGH KOHLI SHRI MANMOHAN KRISHNAN ( <i>Alternate</i> )
Shri Krishna Test House, Delhi	SHRI SUNIL TALWAR
Sunflame Enterprises Private Limited, Faridabad	SHRI K. L. VERMA SHRI SANDEEP JUNEJA ( <i>Alternate</i> )

<i>Organization</i>	<i>Representative(s)</i>
Vanaz Engineers Limited, Pune	SHRI A. A. TAMBOLI SHRI V. N. PUJARI ( <i>Alternate</i> )
BIS Directorate General	SHRI K.V RAO, SCIENTIST 'F'/SENIOR DIRECTOR AND HEAD (MECHANICAL ENGINEERING) [REPRESENTING DIRECTOR GENERAL ( <i>Ex - officio</i> )]

*Member Secretary*  
SHRI SANDEEP KESHAV  
SCIENTIST 'C'/DEPUTY DIRECTOR  
(MECHANICAL ENGINEERING), BIS

(Continued from second cover)

- ak) Strength and endurance test has been added as new test;
- am) Marking requirements has been changed; and
- an) New clause has been added for instructions for use, maintenance and assembly.

The composition of the Committee responsible for the preparation of this standard is given in [Annex E](#).

For the purpose of deciding whether a particular requirement of this standard is complied with the final value, IS 2 : 2022 'Rules for rounding of numerical values (*second revision*)'. The number of significant places retained in the rounded of value should be same as that of the specified value in this standard.

## Bureau of Indian Standards

BIS is a statutory institution established under the *Bureau of Indian Standards Act, 2016* to promote harmonious development of the activities of standardization, marking and quality certification of goods and attending to connected matters in the country.

### Copyright

BIS has the copyright of all its publications. No part of these publications may be reproduced in any form without the prior permission in writing of BIS. This does not preclude the free use, in the course of implementing the standard, of necessary details, such as symbols and sizes, type or grade designations. Enquiries relating to copyright be addressed to the Head (Publication & Sales), BIS.

### Review of Indian Standards

Amendments are issued to standards as the need arises on the basis of comments. Standards are also reviewed periodically; a standard along with amendments is reaffirmed when such review indicates that no changes are needed; if the review indicates that changes are needed, it is taken up for revision. Users of Indian Standards should ascertain that they are in possession of the latest amendments or edition by referring to the website-[www.bis.gov.in](http://www.bis.gov.in) or [www.standardsbis.in](http://www.standardsbis.in).

This Indian Standard has been developed from Doc No.: MED 23 (24642).

### Amendments Issued Since Publication

Amend No.	Date of Issue	Text Affected

## BUREAU OF INDIAN STANDARDS

### Headquarters:

Manak Bhavan, 9 Bahadur Shah Zafar Marg, New Delhi 110002

Telephones: 2323 0131, 2323 3375, 2323 9402

Website: [www.bis.gov.in](http://www.bis.gov.in)

### Regional Offices:

Central : 601/A, Konnectus Tower -1, 6<sup>th</sup> Floor,  
DMRC Building, Bhavbhuti Marg, New  
Delhi 110002

Telephones

{ 2323 7617

Eastern : 8<sup>th</sup> Floor, Plot No 7/7 & 7/8, CP Block, Sector V,  
Salt Lake, Kolkata, West Bengal 700091

{ 2367 0012  
{ 2320 9474

Northern : Plot No. 4-A, Sector 27-B, Madhya Marg,  
Chandigarh 160019

{ 265 9930

Southern : C.I.T. Campus, IV Cross Road, Taramani, Chennai 600113

{ 2254 1442  
{ 2254 1216

Western : 5<sup>th</sup> Floor/MTNL CETTM, Technology Street, Hiranandani Gardens, Powai  
Mumbai 400076

{ 2570 0030  
{ 2570 2715

COIMBATORE, DEHRADUN, DELHI, FARIDABAD, GHAZIABAD, GUWAHATI,  
HARYANA (CHANDIGARH), HUBLI, HYDERABAD, JAIPUR, JAMMU, JAMSHEDPUR,  
KOCHI, KOLKATA, LUCKNOW, MADURAI, MUMBAI, NAGPUR, NOIDA, PARWANOO,  
PATNA, PUNE, RAIPUR, RAJKOT, SURAT, VIJAYAWADA.