

ट्री प्रूनर — विशिष्टि
(पहला पुनरीक्षण)

Tree Pruner — Specification
(First Revision)

ICS 65.060.70

© BIS 2024



भारतीय मानक ब्यूरो
BUREAU OF INDIAN STANDARDS
मानक भवन, 9 बहादुर शाह ज़फर मार्ग, नई दिल्ली - 110002
MANAK BHAVAN, 9 BAHADUR SHAH ZAFAR MARG
NEW DELHI - 110002
www.bis.gov.in www.standardsbis.in

FOREWORD

This Indian Standard (First Revision) was adopted by the Bureau of Indian Standards, after the draft finalized by the Agricultural Machinery and Equipment Sectional Committee had been approved by the Food and Agriculture Division Council.

A tree pruner is a hand tool used for removing unwanted branches/twigs of the tree for giving proper framework and aeration to the tree. Tree pruner can be used to remove the unwanted branches/twigs more conveniently with less effort and saving time. Nowadays long reach tree pruner is used to cut branches which are beyond the reach of human hand and is thus a more powerful tool for the modern gardener. The long reach tree pruner is fixed on the top of a bracket which is fixed with lightweight aluminium or fibre glass pipe, and the blade is actuated by a nylon strip/rope which returns to the original position with the help of tension spring. Height can be extended through telescopic pipe (optional) which is used for cutting of green limbs from far away branches of tree without using ladder. It can cut the branches at different angles also.

This standard was first published in 1983. The revision of this standard incorporates the following changes:

- a) Types of tree pruner are briefly explained with the help of graphical representation and dimensional figures for guidance of users;
- b) Details of long reach tree pruner has been added;
- c) Hardness, size and dimensions of tree pruner has been modified as per current manufacturing practices; and
- d) Raw material requirements of the tree pruner have been updated as per the current manufacturing practices.

The figures in the standard are given only for typical illustration and should not be considered as suggestive of any standard design.

In revision of this standard, considerable assistance has been derived from the technical information provided by Agricultural Machinery Manufacturers Association, Pune, India.

The composition of the Committee responsible for the formulation of this standard is given in [Annex B](#).

For the purpose of deciding whether a particular requirement of this standard is complied with, the final value, observed or calculated expressing the result of a test or analysis, shall be rounded off in accordance with IS 2 : 2022 'Rules for rounding off numerical values (*second revision*)'. The number of significant places retained in the rounded off value should be the same as that of the specified value in this standard.

Indian Standard
TREE PRUNER — SPECIFICATION
(First Revision)

1 SCOPE

This standard specifies material, dimensional and other requirements for tree pruner.

2 REFERENCES

The standards listed in [Annex A](#) contain provisions which, through reference in this text, constitute provisions of this standard. At the time of publication, the editions indicated were valid. All standards are subject to revision and parties to agreements based on this standard are encouraged to investigate the possibility of applying the most recent edition of these standards.

3 TYPES

3.1 Tree Pruner

A simple gardening equipment used by gardner/farmer to cut unwanted branches/twigs which are in reach of the human hand. The various parts of the tree pruner are given in [Fig. 1](#) to [Fig. 7](#).

3.2 Long Reach Tree Pruner

A tree pruner used to cut branches/twigs which are beyond the reach of human hand. The various parts of the long reach tree pruner are given in [Fig. 8](#) and [Fig. 9](#).

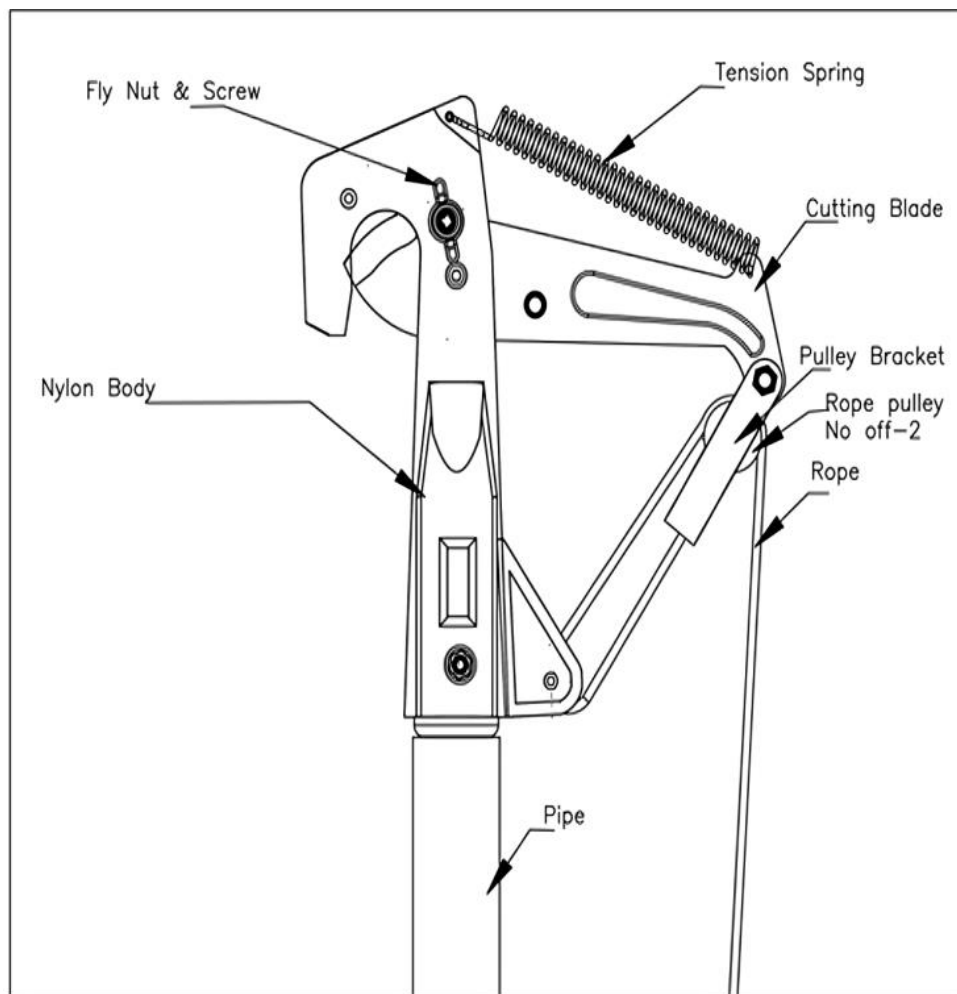

FIG. 1 TYPICAL EXAMPLE OF TREE PRUNER ASSEMBLY

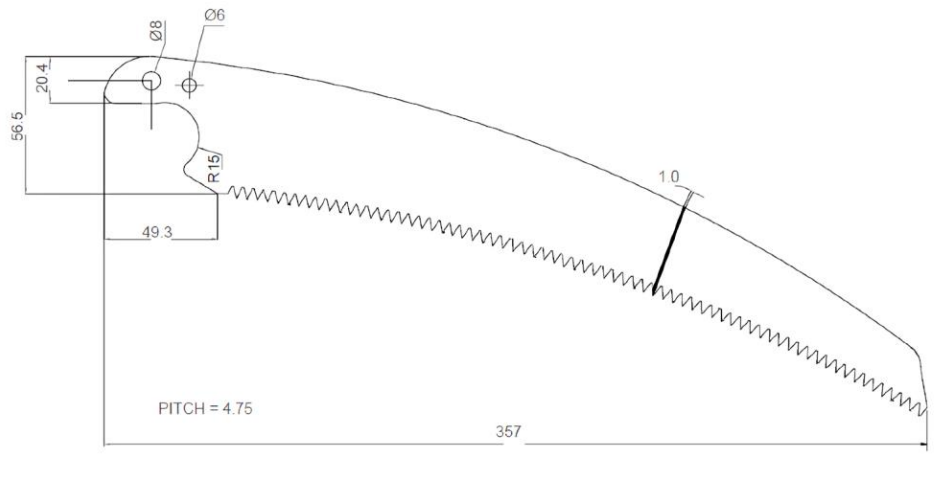

FIG. 2 TYPICAL DIMENSIONS OF CUTTING SAW FOR TREE PRUNER

(All dimensions are in mm unless stated otherwise)

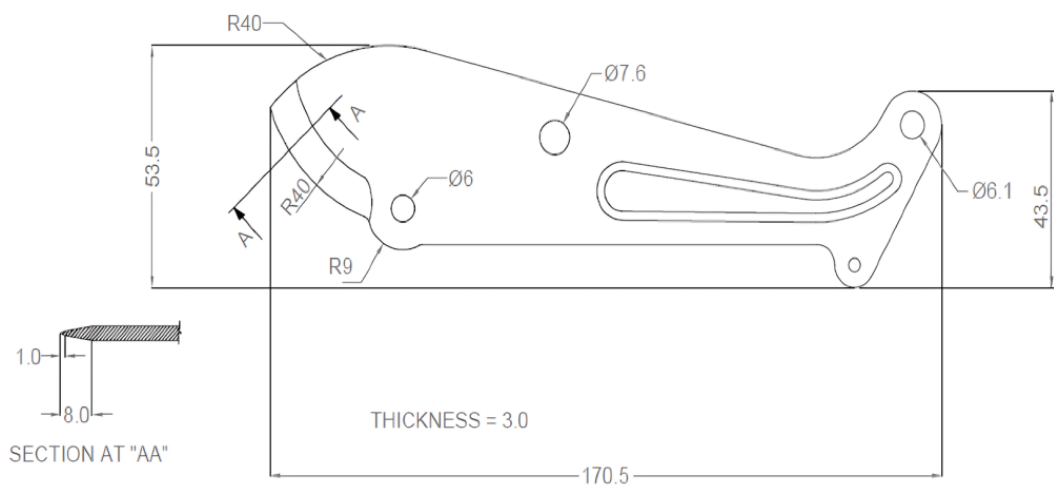

FIG. 3 TYPICAL DIMENSIONS OF CUTTING BLADE FOR TREE PRUNER

(All dimensions are in millimetres unless stated otherwise)

4 MATERIALS

4.1 Blade

The blade of the tree pruner shall be manufactured from carbon steel [see IS 1570 (Part 2/Sec 1)] or stainless steel (see IS 6911).

4.1.1 The chemical composition of the carbon steel shall be as follows:

a) Carbon — 0.7 percent to 0.9 percent;

b) Silicon — 0.1 percent to 0.4 percent;

c) Manganese — 0.5 percent to 1.0 percent;

d) Sulphur — 0.05 percent, *Max*; and

e) Phosphorus — 0.05 percent, *Max*.

Some of the examples of carbon steels that may be used are C70, C80 and C85 [see IS 1570 (Part 2/ Sec 1)].

4.1.2 The chemical composition of stainless steel (*see* IS 6911) as:

- a) Carbon — 0.26 percent to 0.4 percent;
- b) Silicon — 1.0 percent, *Max*;
- c) Manganese — 0.6 percent to 1.0 percent;
- d) Sulphur — 0.03 percent, *Max*;
- e) Phosphorus — 0.03 percent, *Max*; and
- f) Chromium — 12 percent to 14 percent.

4.2 Body Links

For body links mild steel (*see* IS 2062) should be used.

4.3 Main Body

The following material shall be used for body:

- a) Nylon 6 (*see* IS 13463); or
- b) Teak wood body with steel bracket.

4.4 Spring

Spring steel wire [*see* IS 4454 (Part 1)] should be used.

4.5 Pipe

Pipe shall be made of aluminium alloy (*see* IS 1285)

or light weight fibre glass.

4.6 Cutting Saw

The saw shall be manufactured from a suitable steel having a carbon content of not less than 0.7 percent. Suitable steels that may be used for this purpose are C70, C75, C80, C85 [*see* IS 1570 (Part 2/Sec 1)]. It should be hardened and tempered.

4.7 Rope

It shall be made of nylon (*see* IS 13643).

5 HARDNESS

The blade shall be heat-treated to have a hardness in range of 48 to 55 HRC [*see* IS 1586 (Part 1)].

6 SIZE

6.1 The size (total length) shall be declared by the manufacturer. The size shall not differ by more than ± 15 mm from the declared value.

6.2 Sizes of various types of tree pruners for guidance of the user have been provided in [Table 1](#).

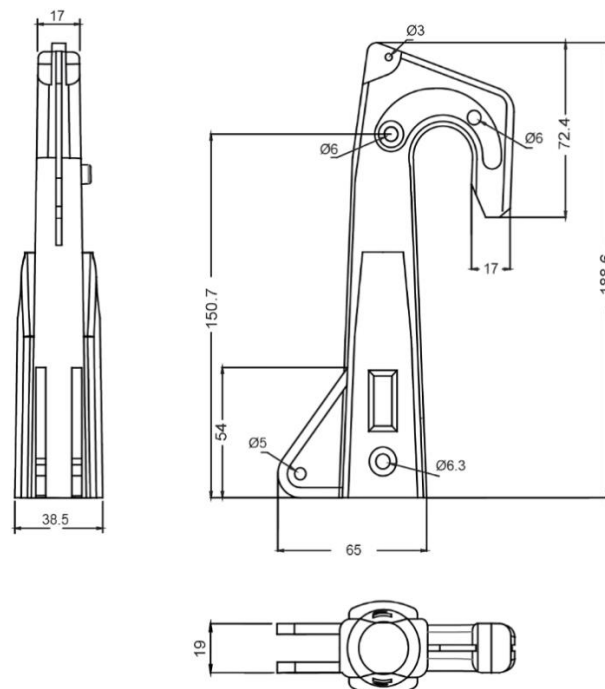

FIG. 4 TYPICAL DIMENSIONS OF BODY OF TREE PRUNER
(All dimensions are in millimetres unless stated otherwise)

7 DIMENSIONS

7.1 The dimensions of various components such as body, cutting saw and blade are given in given in Fig. 2, Fig. 3 and Fig. 4 for guidance of users. The tolerance on various dimensions, unless specified otherwise, shall be ± 5 percent.

7.2 Dimensions of aluminium and fibre glass handle (see Fig. 6C and Fig. 7) which is attached to tree pruners are given in Table 2.

7.3 The diameter of wire for tension spring shall be minimum 1.4 mm for plastic body and 1.75 mm for

wooden body. The spring shall have 25 and 27 coils respectively.

7.4 Details of long reach tree pruner are given in Fig. 8.

7.5 There shall be an operating nylon strip of 1.0 mm thick, 6.0 mm wide and of length as required for long reach tree pruner as shown in Fig. 8 and Fig. 9. The tolerance on various dimensions, unless specified otherwise, shall be ± 3 percent.

Table 1 Sizes of Various Types of Tree Pruners

(Clause 6.2)

SI No.	Type	Length, (mm)	Reference Figures
(1)	(2)	(3)	(4)
i)	Length (L1) of wooden body tree pruner without saw and handle, without top of the blade	445	see Fig. 6A
ii)	Length (L2) of wooden body tree pruner with saw, without handle	780	see Fig. 6B
iii)	Length (L3) of wooden body tree pruner without saw and handle, with top of the blade	530	see Fig. 6A
iv)	Length (L) of wooden body tree pruner with saw	2 760 to 2 810	see Fig. 6C
v)	Length (L) of wooden body tree pruner without saw	2 425 to 2 475	—
vi)	Length (L) of plastic body tree pruner with saw	2 530 to 2 580	see Fig. 5A
vii)	Length (L) of plastic body tree pruner without saw	2 200 to 2 250	see Fig. 5B

NOTE — The tolerance on various dimensions, unless specified otherwise, shall be ± 3 mm.

Table 2 Dimension for Aluminium and Fibre Glass Handle

(Clause 7.2)

SI No.	Handle Type	Length (mm)	Diameter (mm)
(1)	(2)	(3)	(4)
i)	Aluminium pipe	2 000 to 2 050	25 to 30
ii)	Fibre glass pipe	2 000 to 2 050	26.5 to 32

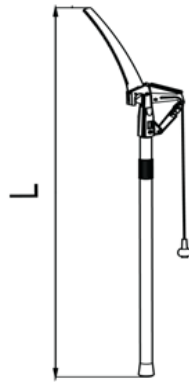

FIG. 5A TREE PRUNER (PLASTIC BODY) WITH CUTTING SAW

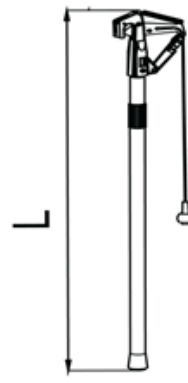

FIG. 5B TREE PRUNER (PLASTIC BODY) WITHOUT CUTTING SAW

FIG. 5 TREE PRUNER (PLASTIC BODY)

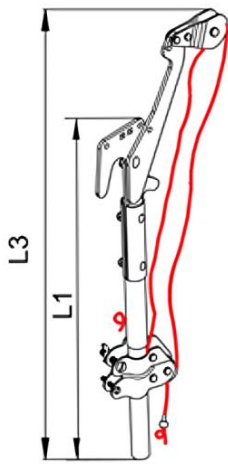

FIG. 6A TREE PRUNER (WOODEN BODY) WITHOUT CUTTING SAW

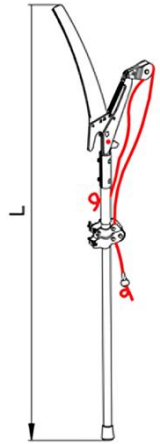

FIG. 6B TREE PRUNER (WOODEN BODY) WITH CUTTING SAW

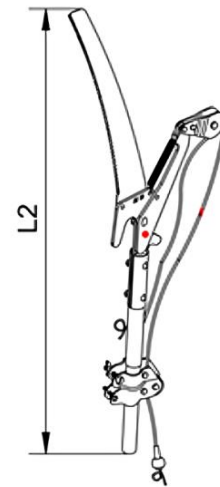

FIG. 6C TREE PRUNER (WOODEN BODY) WITH CUTTING SAW ATTACHED WITH ALUMINIUM/FIBRE GLASS HANDLE

FIG. 6 TREE PRUNER (WOODEN BODY)

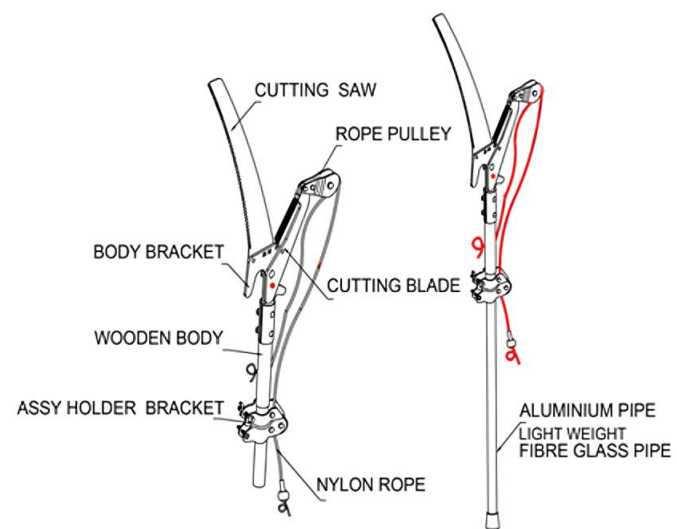

FIG. 7 COMPLETE TREE PRUNER (WOODEN BODY) ATTACHED WITH OPTIONAL ALUMINIUM OR LIGHT WEIGHT FIBRE GLASS HANDLE

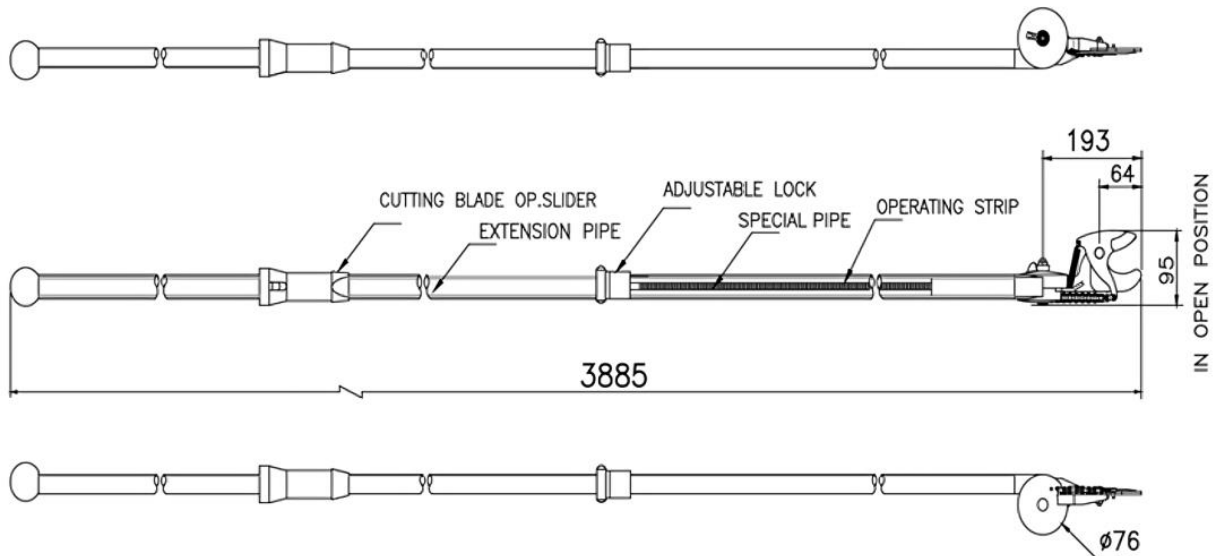

FIG. 8 TYPICAL EXAMPLE OF LONG REACH TREE PRUNER ATTACHED WITH TELESCOPIC ALUMINIUM OR LIGHT WEIGHT FIBRE GLASS PIPE

(All dimensions are in millimetres unless stated otherwise)

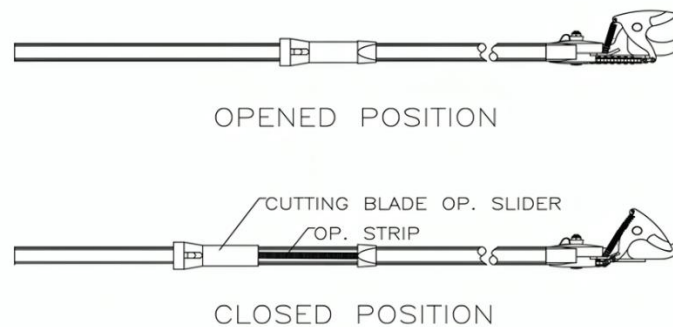

FIG. 9 TYPICAL EXAMPLE OF LONG REACH TREE PRUNER WITH CLOSED AND OPEN POSITION OF CUTTING BLADE

8 OTHER REQUIREMENTS

8.1 The blade of the pruner shall be made of sheet metal which shall be hardened and tempered. The edges are sufficiently sharpened by suitable grinding operation.

8.2 The blade shall be fitted in the body so that it can freely move when pulled with rope. The blade shall come back inside the body by the spring action.

8.3 In the closed position the cutting edge of the blade shall remain inside the body and shall not protrude.

8.4 A circular ring shall be provided for tying the rope with the pruner.

8.5 A hole shall be provided for proper fixing up of the handle with the socket of the body.

8.6 Apart from cutting blade a powerful hardened and tempered cutting saw shall be provided optionally as per requirement of the customer to cut higher diameter of branches easily and effectively.

8.7 Long reach tree pruner is a new kind of pruner that cuts the branches easily and effortlessly. It can be extended optionally as per requirement of the

customer up to 4 m, Fig. 6 shows the closed and open position of cutting blade.

8.8 Cutting capacity of the pruner should be to cut branches of diameter 10 mm to 22 mm.

9 TESTS

9.1 The pruner shall be tested by cutting not less than 20 samples of grafts, not exceeding 15 mm in diameter of citrus, guava, mango or apple suitably prepared in green condition. The cut on the bark shall be clean.

9.2 The pruner with saw attachment shall be tested by cutting not less than 6 samples of hardwood, not exceeding 25 mm in diameter.

10 WORKMANSHIP AND FINISH

10.1 The cutting surface of the blade shall be ground in a direction, preferably, at right angle to the cutting edge. The blade shall be puffed to give a fine finish. The cutting edge shall be sharp enough for immediate use. All the sharp edges, except the cutting edge shall be rounded.

10.2 The blade shall be free from cracks, seams, pits, burrs and other visual defects.

11 PACKING AND MARKING

11.1 Marking

Each tree pruner shall be marked with the following

particulars:

- a) Manufacturer's name or recognized trademark, if any;
- b) **Size**;
- c) Batch or code number; and
- d) Any other markings required under the *Legal Metrology (Packaged Commodities) Rules, 2011* and any other statutory requirement.

11.2 Packing

Because of highly sharp edges the exposed metallic parts shall be packed with proper thick paper or plastic sheet, such as blister type or pouch type of packing to prevent any accidental damage of the product or injury to any human being.

11.3 BIS Certification Marking

The product(s) conforming to the requirements of this standard may be certified as per the conformity assessment schemes under the provisions of the *Bureau of Indian Standards Act, 2016* and the Rules and Regulations framed thereunder, and the products may be marked with the Standard Mark.

12 SAMPLING FOR LOT ACCEPTANCE

Unless otherwise agreed to between the purchaser and the supplier, sampling of the pruner for lot acceptance shall be as per IS 7201 (Part 1).

ANNEX A

(Clause 2)

LIST OF REFERRED STANDARDS

<i>IS No.</i>	<i>Title</i>	<i>IS No.</i>	<i>Title</i>
IS 1285 : 2023	Wrought aluminium and aluminium alloys — Extruded round tube and hollow sections for general engineering purposes — Specification (<i>fourth revision</i>)	IS 4454 (Part 1) : 2001	Steel wire for mechanical springs — Specification: Part 1 Cold drawn unalloyed steel wire (<i>third revision</i>)
IS 1570 (Part 2/ Sec 1) : 1979	Schedules for wrought steels: Part 2 Carbon steels (unalloyed steels), Section 1 Wrought products (other than wires) with specified chemical composition and related properties (<i>first revision</i>)	IS 6911 : 2017	Stainless steel plate, sheet and strip — Specification (<i>second revision</i>)
IS 1586 (Part 1) 2018/ISO 6508-1 : 2016	Metallic materials — Rockwell hardness test: Part 1 test method (<i>fifth revision</i>)	IS 7201 (Part 1) : 1987	Methods of sampling for agricultural machinery and equipment: Part 1 Hand-tools and hand-operated/animal drawn equipment (<i>first revision</i>)
IS 2062 : 2011	Hot rolled medium and high tensile structural steel — Specification (<i>seventh revision</i>)	IS 13463 : 2022	Polyamide 6 materials for moulding and extrusion — Specification (<i>first revision</i>)

To access Indian Standards click on the link below:

https://www.services.bis.gov.in/php/BIS_2.0/bisconnect/knowyourstandards/Indian_standards/isdetails/

ANNEX B

(Foreword)

COMMITTEE COMPOSITION

Agricultural Machinery and Equipment Sectional Committee, FAD 11

<i>Organization</i>	<i>Representative(s)</i>
ICAR - Central Institute of Agricultural Engineering, Bhopal	DR C. R. MEHTA (<i>Chairperson</i>)
Agricultural Machinery Manufacturers Association (AMMA-India), Gandhinagar	DR SURENDRA SINGH SHRI MITUL PANCHAL (<i>Alternate</i>)
All India Farmers Alliance, New Delhi	DR RAJARAM TRIPATHI SHRIMATI APURVA TRIPATHI (<i>Alternate</i>)
Aspee Agro Equipment Private Limited, Mumbai	SHRI JATIN S. PATEL SHRI GANGADHAR VARPE (<i>Alternate</i>)
Automotive Research Association of India, Pune	SHRI A. AKBAR BADUSHA SHRI GIRISH TANAWADE (<i>Alternate I</i>) SHRI GANGARAM AUTI (<i>Alternate II</i>)
CCS Haryana Agricultural University, Hisar	DR VIJAYA RANI
Central Farm Machinery Training and Testing Institute, Budni	SHRI ANIL KUMAR UPADHYAY SHRI BABUL NATH DIXIT (<i>Alternate I</i>) SHRI PARTH LODH (<i>Alternate II</i>)
CLAAS India Private Limited, Chandigarh	SHRI KRISHNA PRABHAKAR SINGH
CNH Industrial India Private Limited, Pune	SHRI SANTHOSH RAO SHRI SUJIT HINGE (<i>Alternate</i>)
Consumer Guidance Society of India, Mumbai	SHRI SITARAM DIXIT
Dasmesh Mechanical Works Private Limited, Malerkotla	SHRI SARBJEET SINGH PANESAR SHRI GURDEEP SINGH PANESAR (<i>Alternate</i>)
ICAR - All India Coordinated Research Project on Ergonomics and Safety in Agriculture, Bhopal	DR SUKHBIR SINGH DR RAHUL R. POTDAR (<i>Alternate I</i>) SHRIMATI SWEETI KUMARI (<i>Alternate II</i>)
ICAR - All India Coordinated Research Project on Farm Implements and Machinery, Bhopal	DR K. N. AGRAWAL
ICAR - All India Coordinated Research Project on Mechanization of Animal Husbandary, Bhopal	DR S. P. SINGH
ICAR - Central Institute of Agricultural Engineering, Bhopal	DR V. P. CHAUDHARY DR U. R. BADEGAONKAR (<i>Alternate I</i>) DR DILIP JAT (<i>Alternate II</i>)
Indian Council of Agricultural Research, New Delhi	DR PANNA LAL SINGH
John Deere India Private Limited, Pune	SHRI ANAND RAJ SHRI CHANDRASHEKHAR DESHMUKH (<i>Alternate I</i>) SHRI PRATIK DURAPHE (<i>Alternate II</i>)
Kerala Agro Machinery Corporation Ltd (KAMCO), Athani	SHRI A. UNNIKRISHNAN SHRI P. C. SAJIMON (<i>Alternate</i>)
KisanKraft Limited, Bengaluru	SHRI RAVINDRA AGARWAL SHRI ANKIT CHITALIA (<i>Alternate I</i>) SHRI SUNIL PRASAD (<i>Alternate II</i>)

<i>Organization</i>	<i>Representative(s)</i>
Kubota Agricultural Machinery India Private Limited, Faridabad	SHRI ASHOK KUMAR SHRI ASHISH KUMAR MALLARH (<i>Alternate</i>)
Maharana Pratap University of Agricultural and Technology, Udaipur	DR SANWAL SINGH MEENA
Mahatma Phule Krishi Vidyapeeth, Rahuri	DR SACHIN MADHUKAR NALAWADE SHRI VIKRAM PARASHARAM KAD (<i>Alternate I</i>) DR AVDHUT ASHOK WALUN (<i>Alternate II</i>)
Mahindra and Mahindra Limited, Mumbai	SHRI PRADEEP SHINDE
Ministry of Agriculture, Department of Agriculture, New Delhi	DR V. N. KALE SHRI ARVIND N. MESHRAM (<i>Alternate</i>)
National Innovation Foundation, New Delhi	SHRI RAKESH MAHESHWARI SHRI MAHESH PATEL (<i>Alternate</i>)
National Institute of Plant Health Management, Hyderabad	DR VIDHU KAMPURATH P. SHRI MUTYALA UDAYA (<i>Alternate</i>)
North Eastern Region Farm Machinery Training and Testing Institute, Biswanath Chariali	DR P. P. RAO SHRI S. G. PAWAR (<i>Alternate I</i>) SHRI KHAGENDRA BORA (<i>Alternate II</i>)
Northern Region Farm Machinery Training and Testing Institute, Hisar	DR MUKESH JAIN SHRI SANJAY KUMAR (<i>Alternate</i>)
Power Tillers Manufacturers Association, Kolkata	SHRI A. R. GANESH KUMAR
Punjab Agricultural University, Ludhiana	DR MAHESH KUMAR NARANG DR RAJESH GOYAL (<i>Alternate I</i>) SHRI APOORV PRAKASH (<i>Alternate II</i>)
Southern Region Farm Machinery Training and Testing Institute, Anantpur	DR B. M. NANDEDE
Tamil Nadu Agricultural University, Coimbatore	DR R. KAVITHA DR A. SURENDRA KUMAR (<i>Alternate I</i>) DR A. P. MOHAN KUMAR (<i>Alternate II</i>)
Tirth Agro Technology Private Limited 'Shaktiman', Rajkot	SHRI PARAG DEVIDAS BADGUJAR SHRI V. AUDHI NARAYAN REDDY (<i>Alternate</i>)
Tractor and Mechanization Association, New Delhi	SHRI PHILIP KOSHY SHRI VEENIT NEGI (<i>Alternate I</i>) SHRIMATI DEVYANI (<i>Alternate II</i>)
Tube Investments Clean Mobility Private Limited, Chennai	SHRI ABHISHEK SINHA SHRI S. O. TYAGI (<i>Alternate</i>)
Voluntary Organisation in Interest of Consumer Education (VOICE), New Delhi	SHRI B. K. MUKHOPADHYAY
In Personal Capacity (201, Memnon Tower, Omaxe The Nile, Sector 49, Sohna Road, Gurugram - 122018)	SHRI VIVEK GUPTA
BIS Directorate General	SHRIMATI SUNEETI TOTEJA, SCIENTIST 'F'/SENIOR DIRECTOR AND HEAD (FOOD AND AGRICULTURE) [REPRESENTING DIRECTOR GENERAL (<i>Ex-officio</i>)]

Member Secretary
SHRI VIKRANT CHAUHAN
SCIENTIST 'B'/ASSISTANT DIRECTOR
(FOOD AND AGRICULTURE), BIS

Panel to Formulate and Review Indian Standards on Gardening and Forestry Tools and Agricultural Implements, FAD 11/P 3

<i>Organization</i>	<i>Representative(s)</i>
Agricultural Machinery Manufacturers Association (AMMA-India), Gandhinagar	DR SURENDRA SINGH (Convener)
ASPEE Agro Equipment Private Limited, Mumbai	SHRI JATIN S. PATEL SHRI GANGADHAR VARPE (<i>Alternate</i>)
Falcon Garden Tools Private Limited, Ludhiana	SHRI GURCHINTAN SINGH DUA
ICAR - Central Institute of Agricultural Engineering, Bhopal	DR DILIP JAT
John Deere India Private Limited, Pune	SHRI CHANDRASHEKHAR DESHMUKH
Mahatma Phule Krishi Vidyapeeth, Rahuri	DR SACHIN MADHUKAR NALAWADE

Bureau of Indian Standards

BIS is a statutory institution established under the *Bureau of Indian Standards Act, 2016* to promote harmonious development of the activities of standardization, marking and quality certification of goods and attending to connected matters in the country.

Copyright

BIS has the copyright of all its publications. No part of these publications may be reproduced in any form without the prior permission in writing of BIS. This does not preclude the free use, in the course of implementing the standard, of necessary details, such as symbols and sizes, type or grade designations. Enquiries relating to copyright be addressed to the Head (Publication & Sales), BIS.

Review of Indian Standards

Amendments are issued to standards as the need arises on the basis of comments. Standards are also reviewed periodically; a standard along with amendments is reaffirmed when such review indicates that no changes are needed; if the review indicates that changes are needed, it is taken up for revision. Users of Indian Standards should ascertain that they are in possession of the latest amendments or edition by referring to the website-www.bis.gov.in or www.standardsbis.in.

This Indian Standard has been developed from Doc No.: FAD 11 (24864).

Amendments Issued Since Publication

Amend No.	Date of Issue	Text Affected

BUREAU OF INDIAN STANDARDS

Headquarters:

Manak Bhavan, 9 Bahadur Shah Zafar Marg, New Delhi 110002

Telephones: 2323 0131, 2323 3375, 2323 9402

Website: www.bis.gov.in

Regional Offices:

	Telephones
Central : 601/A, Konnectus Tower -1, 6 th Floor, DMRC Building, Bhavbhuti Marg, New Delhi 110002	{ 2323 7617
Eastern : 8 th Floor, Plot No 7/7 & 7/8, CP Block, Sector V, Salt Lake, Kolkata, West Bengal 700091	{ 2367 0012 2320 9474
Northern : Plot No. 4-A, Sector 27-B, Madhya Marg, Chandigarh 160019	{ 265 9930
Southern : C.I.T. Campus, IV Cross Road, Taramani, Chennai 600113	{ 2254 1442 2254 1216
Western : 5 th Floor/MTNL CETTM Technology Street, Hiranandani Gardens, Powai, Mumbai - 400076	{ 25700030 25702715

Branches : AHMEDABAD, BENGALURU, BHOPAL, BHUBANESHWAR, CHANDIGARH, CHENNAI, COIMBATORE, DEHRADUN, DELHI, FARIDABAD, GHAZIABAD, GUWAHATI, HARYANA (CHANDIGARH), HUBLI, HYDERABAD, JAIPUR, JAMMU, JAMSHEDPUR, KOCHI, KOLKATA, LUCKNOW, MADURAI, MUMBAI, NAGPUR, NOIDA, PARWANOO, PATNA, PUNE, RAIPUR, RAJKOT, SURAT, VIJAYAWADA.