

सिंचाई उपकरण — उत्सर्जक — विशिष्टि
(पहला पुनरीक्षण)

Irrigation Equipment — Emitters —
Specification
(First Revision)

ICS 65.060.35

© BIS 2024



भारतीय मानक ब्यूरो
BUREAU OF INDIAN STANDARDS
मानक भवन, 9 बहादुर शाह ज़फर मार्ग, नई दिल्ली - 110002
MANAK BHAVAN, 9 BAHADUR SHAH ZAFAR MARG
NEW DELHI - 110002
www.bis.gov.in www.standardsbis.in

December 2024

Price Group 6

FOREWORD

This Indian Standard (First Revision) was adopted by the Bureau of Indian Standards, after the draft finalized by the Farm Irrigation and Drainage Systems Sectional Committee had been approved by the Food and Agriculture Division Council.

Emitters, also known as drippers, are devices used in drip irrigation systems to deliver water directly to the root zone of plants in form of droplets. As the adoption of drip irrigation system increased among the Indian farmers, a need was felt to develop a standard for manufacturers to produce and for users to select quality emitters.

The standard was published in 1992 deriving assistance from ISO/DIS 9260 'Irrigation equipment — Emitters — Specification and test methods' prepared by the International Organization for Standardization. The revision of this standard has been brought out to incorporate following modifications:

- a) Amendments issued to the earlier version of the standard have been incorporated;
- b) Procedure for measuring uniformity of emission rate has been modified as currently being followed by manufacturers; and
- c) Determination of emitter exponent has been modified and would be applicable to both types of emitters that is, regulated and unregulated.
- d) Determination of emitter unit constant has been added.
- e) Necessary editorial changes have been made including updating of referred Indian Standards and the schematic diagrams given in the standard.

The composition of the Committee responsible for the formulation of this standard is given in [Annex A](#).

For the purpose of deciding whether a particular requirement of this standard is complied with, the final value, observed or calculated expressing the result of a test or analysis, shall be rounded off in accordance with IS 2 : 2022 'Rules for rounding off numerical values (*second revision*)'. The number of significant places retained in the rounded off value should be the same as that of the specified value in this standard.

Indian Standard

IRRIGATION EQUIPMENT — EMITTERS — SPECIFICATION

(*First Revision*)

1 SCOPE

1.1 This standard specifies mechanical and functional requirements of irrigation emitters, test methods and the data to be supplied by the manufacturer to permit correct installation and operation in the field.

1.2 It applies to emitters, with or without pressure regulation, intended for irrigation; it does not apply to emitters which form an integral part of the pipe during manufacture as well as micro tubes.

2 REFERENCES

The standards given below contain provisions which through reference in this text, constitute provisions of this standard. At the time of publication, the editions indicated were valid. All standards are subject to revision and parties to agreements based on this standard are encouraged to investigate the possibility of applying the most recent edition of these standards:

<i>IS No.</i>	<i>Title</i>
IS 12786 : 2024	Irrigation equipment — Polyethylene pipes for irrigation laterals — Specification (<i>first revision</i>)
IS 13479 : 1992	Assembled joints between fittings and polyethylene pressure pipes — Test of resistance to pull out

3 DEFINITIONS

For the purpose of this standard the following definitions shall apply.

3.1 Emitter — Device fitted to an irrigation lateral and intended to emit water in the form of drops or continuous flow at emission rates not exceeding 15 litres per hour per outlet except during flushing.

3.2 In-Line Emitter — Emitter intended for installation between two lengths of pipe (irrigation lateral).

3.3 On-Line Emitter — Emitter intended for direct or indirect (for example, by means of tubing) installation in the wall of the irrigation lateral.

3.4 Multiple-Outlet Emitter — Emitter in which the output flow is divided and directed to several distinctly different locations.

3.5 Unregulated (Non-Compensating) Emitter — Emitter of varying emission rate at varying water pressure at emitter inlet.

3.6 Regulated (Pressure-Compensating) Emitter — Emitter of relatively constant emission rate at varying water pressures at the emitter inlet within the limits specified by the manufacturer.

3.7 Emitter Inlet — Point at which water enters the emitter.

3.8 Emitter Outlet — Opening, or group of all the openings in an emitter, from which water is emitted and directed to one clearly distinguishable location.

3.9 Irrigation Lateral — Branch supply pipe or tubing fitted with emitters.

3.10 Nominal Test Pressure, P_a — Reference pressure of 100 kPa at the inlet of the unregulated emitter; or any other pressure so designated in the manufacturer's publications.

3.11 Range of Working Pressures — Range of water pressures at the emitter inlet between and including the minimum working pressure, P_{min} and the maximum working pressure, P_{max} recommended by the emitter manufacturer to ensure proper operation.

3.12 Range of Regulation — Range of pressures at the inlet of the regulated emitter in which the emitter discharges water within the range of the emission rates as specified by the manufacturer.

3.13 Nominal Emission Rate, q_n

3.13.1 Unregulated Emitter Nominal Emission Rate — Emission rate, in litres per hour (l/h), of the emitter at nominal test pressure and at a water temperature of 27 °C as specified by the manufacturer.

3.13.2 Regulated Emitter Nominal Emission Rate — Emission rate, in litres per hour (l/h), of the emitter operating in the range of regulation and at a water temperature of 27 °C as specified by the manufacturer.

To access Indian Standards click on the link below:

https://www.services.bis.gov.in/php/BIS_2.0/bisconnect/knowyourstandards/Indian_standards/isdetails/

3.13.3 Multiple-Outlet Emitter Nominal Emission Rate — Emission rate of the emitter.

3.14 Emitter Spacing — It is the distance between two successive emitters fitted to the irrigation lateral.

4 CLASSIFICATION

Emitters are classified, according to their uniformity of emission rate and of regulation, into two uniformity categories:

- a) Uniformity Category A — Emitters having a higher uniformity of emission rates and smaller deviations from the specified nominal emission rate (and for regulated emitters, better regulation of emission rates).
- b) Uniformity Category B — Emitter having a lower uniformity of emission rate and greater deviations from the specified nominal emission rate (and for regulated emitters, inferior regulation of emission rates).

NOTE — [8.1](#) and [8.2](#) define the requirement for each category.

5 CONSTRUCTION AND MATERIALS

5.1 Connections

Emitter connections to the supply shall be as required by the manufacturer, provided that the connection complies with the requirements of this standard relating to resistance to internal hydraulic pressure and to pull-out. The manufacturer shall supply any special tools required for installation.

5.2 Emitter Ends

When polyethylene (PE) pipe is used, in-line emitter ends shall not increase the diameter of the polyethylene (PE) pipe by more than 20 percent.

NOTE — Dimensions of the polyethylene (PE) pipe laterals shall be as given in [5](#) of IS 12786.

5.3 Materials

The materials used in emitter construction shall be suitable for use with water, fertilizers and chemicals commonly used in irrigation, including treated sewage water. The materials shall, to the extent possible, neither support the growth of algae and bacteria, nor be of metal which will corrode. Plastic parts of the emitter that are exposed to light shall be opaque and protected against UV degradation.

6 TEST SPECIMENS AND CONDITIONS

6.1 Test Specimens

Test specimens shall be selected at random by the representative of the test laboratory from a lot of at least 500 units. The total number of test specimens shall be at least 25. The number of test specimens required for each test is specified in the relevant clause.

6.2 Test Conditions

6.2.1 For test purpose, test specimens shall be assembled on a pipe following the recommendations of the manufacturer as to type of pipe, assembly tools and connection. When polyethylene (PE) pipe is used, the pipe shall comply with the requirements of IS 12786.

6.2.2 The use of grease or chemicals that may affect the properties of the pipe or the emitters is prohibited when attaching emitters to pipes. If the manufacturer supplies the emitters normally attached to the pipe, lengths or such emitter assemblies may be used as test samples.

6.2.3 All the tests shall be carried out at a water temperature of $27\text{ }^{\circ}\text{C} \pm 3\text{ }^{\circ}\text{C}$. The water used shall be filtered through a filter with nominal aperture of $75\text{ }\mu\text{m}$ to $100\text{ }\mu\text{m}$ (micrometre) (160 to 200 mesh), or as recommended by the manufacturer.

6.3 Accuracy or Measuring Devices

The water pressure shall be measured with an error not more than 0.002 MPa. During the test, the pressure shall not vary by more than $\pm 0.002\text{ MPa}$ and emission rate of the emitter shall be measured with an error not more than ± 2 percent.

7 MECHANICAL TESTS AND REQUIREMENTS

7.1 Construction and Workmanship

7.1.1 If designed for disassembly, disassemble at least three emitters into their component parts. If not, prepare a cross section of the emitters. Inspect for visual defects.

7.1.2 The emitter and its parts shall show no manufacturing defects such as grooves or projections in flow path surfaces, cracks or cavities which may adversely affect emitter operation.

7.2 Flow Paths in Emitter

Measure in at least three emitters, accurately to the nearest 0.02 mm and under no pressure, the smallest

dimension of the flow path (this does not apply to a dimension that varies with pressure). The smallest measured flow path dimension shall not be smaller than the dimension declared by the manufacturer.

7.3 Resistance to Hydrostatic Pressure

Connect one end of the emitter pipe assembly to a source or hydraulic pressure and plug the other end of the assembly.

Perform the test on at least five emitters connected to a lateral. Carry out the test in two stages (7.3.1 and 7.3.2).

7.3.1 Test the water tightness of the assembly as follows:

7.3.1.1 Increase the pressure in three steps:

- 5 minutes at 0.4 times maximum working pressure;
- Then another 5 minutes at 0.8 times maximum working pressure; and
- Then 60 minutes at 1.2 times maximum working pressure.

7.3.1.2 No leakage shall occur through the emitter bodies or their connections to the pipe, except at points of emitter discharge.

7.3.2 Immediately after completion of stage 7.3.1, raise the pressure to twice the maximum working pressure and maintain for 5 minutes.

The emitters shall withstand the test pressure without suffering damage and without pulling out from the assembly.

7.3.3 If the emitters contain parts that can be disassembled for cleaning or replacement and reassembled, the test in 7.3.1 and 7.3.2 shall be

performed after reassembling the emitter, according to the manufacturer's instructions, three times in succession.

7.4 Emitter Pull-Out

This test shall be conducted at an ambient temperature of $27\text{ }^{\circ}\text{C} \pm 1\text{ }^{\circ}\text{C}$.

7.4.1 In-Line Emitters

Perform the test on at least three lengths of lateral, each containing one emitter. Gradually apply an axial tensile force, F , on the two lengths of pipe connected to the emitter, where F is calculated from the following formula, but not greater than 500 N.

$$F = 1.5 \pi \sigma_t e (D - e)$$

where

- F = pull out force, N;
 σ_t = permissible induced stress for pipe material (N/mm^2);
 e = pipe wall thickness, minimum (mm); and
 D = outside diameter of pipe (mm).

Apply this tensile force, F , for 1 hour with the emitter vertical and apply the pull-out force by means of a weight or by the apparatus described in IS 13479.

The emitters shall withstand the tensile force, F , without the pipes pulling out.

7.4.2 On-Line Emitters

Gradually apply a pulling force of 40 N on the emitter perpendicular to the pipe for 1 hour (see Fig. 1). The emitter shall withstand the pulling force without pulling out the pipe wall.

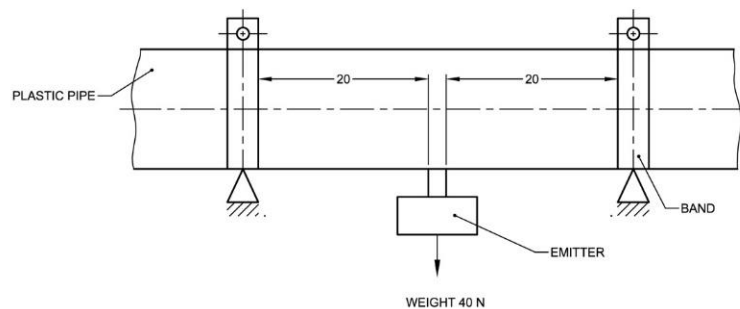

All dimension in millimetres.

FIG. 1 ON-LINE EMITTER PULL-OUT TEST

8 FUNCTIONAL TESTS AND REQUIREMENTS

8.1 Uniformity of Emission Rate

8.1.1 Number of Test Samples

The number of test samples shall be as follows:

- a) Single-outlet emitter; at least 25 emitters; and
- b) Multiple-outlet emitter; at least 25 outlets and not less than 10 emitters. All the outlets of the emitters in the sample shall be open, and all of them shall be included in the test.

8.1.2 Unregulated Emitters

8.1.2.1 Measure the emission rates of the emitters in the test sample when the water pressure at the emitter inlets equals the nominal test pressure. Record separately the measured emission rate at each emitter outlet. For the purpose of measuring emission rate, following procedure to be followed:

- a) For emitters with rated emission rate up to and including 8 l/h, collect a water sample from each emitter outlet for at least 3 minutes and then calculate the emission rate for each outlet; and
- b) For emitters with rated emission rate greater than 8 l/h, collect a water sample from each emitter outlet for at least 2 minutes and then calculate the emission rate for each outlet.

NOTES

1 For collecting the water, measuring cylinders of different sizes may be used.

2 If the emitter contains movable parts, condition the emitter as described in [8.1.3](#) before conducting the list.

8.1.2.2 Calculate the coefficient of variation, C_v from the following formula:

$$C_v = \frac{S_q}{\bar{q}} \times 100$$

where

S_q = standard deviation of the emission rates for the sample; and

\bar{q} = mean emission rate of sample.

8.1.2.3 The following requirements shall be met:

- a) The mean emission rate of the test sample shall not deviate from the nominal emission rate, q_n , by more than 5 percent for Category A, not more than 10 percent for Category B.

- b) The coefficient of variation C_v of the emission rate of the test sample shall not exceed 5 percent for Category A not more than 10 percent for Category B.

For multiple outlet emitters, the requirements in a) and b) shall apply both to the emission rates of the individual outlets and to the emission rates of the complete emitters.

8.1.3 Regulated Emitters

8.1.3.1 Condition the emitters in the test sample by operating them for 1 h minimum at an emitter inlet pressure equal to the pressure at the middle of the working pressure range. At the beginning of conditioning the emitters shall be operated three times at about P_{max} and three times at about P_{min} , each operation to be maintained for at least 3 min. During the last 10 min of conditioning the pressure shall be maintained at the mid-point of the regulation range.

8.1.3.2 Immediately after and without altering the inlet pressure test the emitters according to [8.1.2](#) but at the mid-point of the regulation range.

8.1.3.3 The emitters shall comply with the requirements of [8.1.2.3](#).

8.2 Emission Rate as Function of Inlet Pressure

The tests to be performed to determine emission rate as a function of pressure shall be made in continuation of the tests performed under [8.1](#).

8.2.1 Selection of Test Samples

8.2.1.1 Number the emitters tested according to [8.1](#) in ascending order according to the measured emission rate, No. 1 being the lowest emission rate emitter, No. 25 the highest.

8.2.1.2 Take four emitters from the series obtained No. 3, 12, 13, 23 and measure their change in emission rate as a function of the inlet pressure.

8.2.1.3 Test each emitter in steps not greater than 50 kPa from zero pressure up to 1.2 P_{max} . Regulated emitters shall be tested at three or more different pressure within the range of regulation at rising and falling inlet pressures. The reading of the results shall be taken at least 3 min after reaching the test pressure.

8.2.1.4 If the inlet pressure exceeds the desired pressure by more than 10 kPa during its rise or fall, return to zero pressure and repeat the test.

8.2.2 Unregulated Emitters

Calculate for each pressure level, the average emission rate \bar{q} obtained by measuring the emission rates of the four emitters at rising pressure.

Plot the curve \bar{q} as a function of inlet pressure. The curve of \bar{q} shall conform to the curve presented in manufacturer's publications within an allowable deviation of ± 5 percent for Category A and ± 10 percent for Category B at any pressure.

8.2.3 Regulated Emitters

Calculate for each inlet pressure level p the average emission rate \bar{q} obtained by measuring the emission rates of the four emitters at rising and falling pressure (the average of eight emission rate measurements).

The value of \bar{q} shall not deviate from the nominal emission rate q_n by more than 5 percent for Category A, not more than 10 percent for Category B.

8.3 Determination of Emitter Exponent

This determination applies to both regulated and unregulated emitters.

8.3.1 The relation between the emission rate \bar{q} in l/h and the inlet pressure in an emitter, p in kPa is given by the formula:

$$\bar{q} = k \cdot p^m$$

where

- \bar{q} = emission rate (l/h);
- k = constant;
- p = inlet pressure (kPa); and
- m = emitting unit exponent.

Using all the \bar{q} and p values obtained in [8.2.2](#) or [8.2.3](#), calculate m from the following formula:

$$m = \frac{\sum (\log p_i)(\log \bar{q}_i) - \frac{1}{n} (\sum \log p_i)(\sum \log \bar{q}_i)}{\sum (\log p_i)^2 - \frac{1}{n} (\sum \log p_i)^2}$$

where

- \bar{q} = mean emission rate value (l/h);
- p = pressure value (kPa);
- i = 1, 2, 3, 4, ..., n; and
- n = the number of pressure values used in [8.2.2](#) or [8.2.3](#).

The manufacturer shall declare the type based on the emitter exponent as follows:

Emitter exponent	Emitter type
< 0.2	Regulated
0.21 to 0.5	Unregulated, turbulent flow
0.51 to 0.75	Unregulated, laminar flow
> 0.75	Unregulated, capillary or orifice flow

8.3.2 The emitter unit constant, k can also be calculated by the following formula:

$$k = \exp \left[\left(\frac{\sum \log \bar{q}_i}{n} \right) - \frac{m \times (\sum \log p_i)}{n} \right]$$

where

\bar{q} = mean emission rate value (l/h);

p = pressure value (kPa);

$i = 1, 2, 3, 4, \dots, n$; and

n = the number of pressure values used in [8.2.2](#) or [8.2.3](#).

9 MARKING AND PACKING

9.1 Each emitter shall bear clear and permanent markings including the following details:

- a) Name of manufacturer or his registered trademark;
- b) Nominal emission rate, in litres per hour;
- c) Arrow indicating the direction of flow (if important for proper operation);
- d) Batch or Code No. may be marked on the package in place of each emitter; and
- e) Uniformity category.

NOTES

1 Nominal emission rate [see (b)] may be indicated by the colour of any part of the emitter, or by any other method described in the manufacturer's literature.

2 Batch or Code No. [see (d)] may be marked on the package in place of each emitter.

9.2 BIS Certification Marking

The product(s) conforming to the requirements of this standard may be certified as per the conformity assessment schemes under the provisions of the *Bureau of Indian Standards Act, 2016* and the Rules and Regulations framed thereunder, and the products may be marked with the Standard Mark.

9.3 Packing

Emitters may be packed in number of 100, 200, 500 and 1 000.

10 DATA TO BE SUPPLIED BY THE MANUFACTURER

The manufacturer shall make available to the user, together with the emitters, catalogues or information sheets that include the following data:

- a) catalogue number of irrigation emitters;
- b) the words ‘Uniformity Category A’ or ‘Uniformity Category B’ as applicable, including the relevant values given in [Table 1](#);
- c) type of pipes suitable for use with the emitter and their dimensions;
- d) type of connection of emitter to pipe;
- e) the dimensions of the smallest flow path in the emitter;
- f) nominal emission rate;
- g) nominal test pressure;
- h) range of working pressures;
- j) range of regulation (if any);
- k) emission rates as function of inlet pressures at different water temperatures;
- m) instruction for emitter assembly un pipe;
- n) instruction for cleaning and replacement of emitters;
- p) instruction for prevention or clogging in emitters;
- q) limitation of emitter use (fertilizers, chemicals, etc);
- r) filtration requirements;
- s) maintenance and storage requirements; and
- t) nominal emission rate during flushing, if applicable.

Table 1 Uniformity Values According to 8.1.2.3

[Clause [10](#), *Sl No.* (b)]

Sl No.	Category	Deviation of \bar{q} from q_n	Coefficient of Variation C_v
(1)	(2)	Max (3)	Max (4)
i)	A	5 percent	5 percent
ii)	B	10 percent	10 percent

ANNEX A

(Foreword)

COMMITTEE COMPOSITION

Farm Irrigation and Drainage Systems Sectional Committee, FAD 17

<i>Organization</i>	<i>Representative(s)</i>
In Personal Capacity (<i>D-26, Pusa Campus, Agricultural Research Institute, New Delhi-110012</i>)	DR T. B. S. RAJPUT (<i>Chairperson</i>)
Automat Industries Private Limited, New Delhi	SHRI DINESH KUMAR SHRI NAWAL KISHORE SHAH (<i>Alternate</i>)
CIPET, Chennai	DR SANDESH KUMAR JAIN SHRI VISHAL VERMA (<i>Alternate</i>)
Dr Y.S. Parmar University of Horticulture and Forestry, Solan	PROF RAJESHWAR SINGH CHANDEL SHRI SUDHIR VERMA (<i>Alternate</i>)
Finolex Plasson Industries Limited, Pune	SHRI VIJAY JADHAV SHRI BAJIRAO BHOSALE (<i>Alternate</i>)
Gujarat Green Revolution Company Limited, Vadodara	DR ASHUTOSH VASANT VADAWALE SHRI R. V. LIMBASHIA (<i>Alternate I</i>) SHRI HARDIK PANCHOLI (<i>Alternate II</i>)
ICAR - Central Institute of Agricultural Engineering, Bhopal	DR RANJAY KUMAR SINGH DR YOGESH A. RAJWADE (<i>Alternate</i>)
ICAR - Central Soil Salinity Research Institute, Karnal	DR DEVENDRA SINGH BUNDELA DR SATYENDRA KUMAR (<i>Alternate</i>)
Indian Council of Agricultural Research, New Delhi	DR KONDAPALLY V. RAMANARAO
Jain Irrigation Systems Limited, Jalgaon	SHRI SUNIL LODHA SHRI ABHIJEET B. JOSHI (<i>Alternate</i>)
Mahatma Phule Krishi Vidyapeeth, Rahuri	DR SACHINKUMAR NANDGUDE DR SHRIMANT RAHOD (<i>Alternate</i>)
Mahindra EPC Irrigation Limited, Nashik	SHRI RAJEEV DESHPANDE SHRI ASHISH KUMAR (<i>Alternate</i>)
National Committee on Precision Agriculture and Horticulture, New Delhi	SHRI ANAND ZAMBRE SHRI ROHIT LALL (<i>Alternate</i>)
Netafim Irrigation Private Limited, Vadodara	SHRI SETHURAMALINGAM S. SHRI MANISH KUMAR PATEL (<i>Alternate</i>)
Nimbus Pipes Limited, Jaipur	SHRI ASHISH KUMAR LATH SHRI HARIDWAR TIWARI (<i>Alternate</i>)
NITI Aayog, New Delhi	DR NEELAM PATEL SHRIMATI ANURADHA BATANA (<i>Alternate</i>)
Premier Irrigation Adritec Limited, Nagpur	SHRI A. K. PRADHAN SHRI G. K. KUMAR (<i>Alternate</i>)
Punjab Agricultural University, Ludhiana	DR J. P. SINGH DR SUNIL GARG (<i>Alternate</i>)
Reliance Industries Limited, Mumbai	SHRI AMIT SHAH
Rivulis Irrigation India Private Limited, Vadodara	SHRI GOPI KETHAVATH

<i>Organization</i>	<i>Representative(s)</i>
Saurashtra Plastics Manufacturer's Association, Rajkot	SHRI ARUN ROKAD SHRI J. K. PATEL (<i>Alternate I</i>) SHRI BHARAT KUMAR V. SIROYA (<i>Alternate II</i>)
School of Agriculture, Indira Gandhi National Open University, New Delhi	DR MUKESH KUMAR
Visvesvaraya Technological University (VTU), Belgavi	DR NAGRAJ S. PATIL
Water Technology Centre, ICAR - Indian Agricultural Research Institute, New Delhi	DR ANIL KUMAR MISHRA DR SUSAMA SUDHISHRI (<i>Alternate</i>)
BIS Directorate General	SHRIMATI SUNEETI TOTEJA, SCIENTIST 'F'/SENIOR DIRECTOR AND HEAD (FOOD AND AGRICULTURE) [REPRESENTING DIRECTOR GENERAL (<i>Ex-officio</i>)]

Member Secretary
SHRI VIKRANT CHAUHAN
SCIENTIST 'B'/ASSISTANT DIRECTOR
(FOOD AND AGRICULTURE), BIS

Panel to Review of Indian Standards on Micro-Irrigation Component, FAD17/P 2

<i>Organization</i>	<i>Representative(s)</i>
Visvesvaraya Technological University (VTU), Belgavi	DR NAGRAJ S. PATIL (<i>Convener</i>)
Finolex Plasson Industries Limited, Pune	SHRI BAJIRAO BHOSALE
Jain Irrigation Systems Limited, Jalgaon	SHRI SUNIL LODHA SHRI ABHIJEET B. JOSHI (<i>Alternate</i>)
Mahindra EPC Irrigation Limited, Nashik	SHRI RAJEEV DESHPANDE SHRI ASHISH KUMAR (<i>Alternate</i>)
National Committee on Precision Agriculture and Horticulture, New Delhi	SHRI ROHIT LALL
Netafim Irrigation Private Limited, Vadodara	SHRI SETHURAMALINGAM S.
Premier Irrigation Adritec Limited, Nagpur	SHRI G. K. KUMAR

Bureau of Indian Standards

BIS is a statutory institution established under the *Bureau of Indian Standards Act, 2016* to promote harmonious development of the activities of standardization, marking and quality certification of goods and attending to connected matters in the country.

Copyright

BIS has the copyright of all its publications. No part of these publications may be reproduced in any form without the prior permission in writing of BIS. This does not preclude the free use, in the course of implementing the standard, of necessary details, such as symbols and sizes, type or grade designations. Enquiries relating to copyright be addressed to the Head (Publication & Sales), BIS.

Review of Indian Standards

Amendments are issued to standards as the need arises on the basis of comments. Standards are also reviewed periodically; a standard along with amendments is reaffirmed when such review indicates that no changes are needed; if the review indicates that changes are needed, it is taken up for revision. Users of Indian Standards should ascertain that they are in possession of the latest amendments or edition by referring to the website-www.bis.gov.in or www.standardsbis.in.

This Indian Standard has been developed from Doc No.: FAD 17 (25120).

Amendments Issued Since Publication

Amend No.	Date of Issue	Text Affected

BUREAU OF INDIAN STANDARDS

Headquarters:

Manak Bhavan, 9 Bahadur Shah Zafar Marg, New Delhi 110002

Telephones: 2323 0131, 2323 3375, 2323 9402

Website: www.bis.gov.in

Regional Offices:

Central : 601/A, Konnectus Tower -1, 6th Floor,
DMRC Building, Bhavbhuti Marg, New
Delhi 110002

Telephones

{ 2323 7617

Eastern : 8th Floor, Plot No 7/7 & 7/8, CP Block, Sector V,
Salt Lake, Kolkata, West Bengal 700091

{ 2367 0012
{ 2320 9474

Northern : Plot No. 4-A, Sector 27-B, Madhya Marg,
Chandigarh 160019

{ 265 9930

Southern : C.I.T. Campus, IV Cross Road, Taramani, Chennai 600113

{ 2254 1442
{ 2254 1216

Western : 5th Floor/MTNL CETTM Technology Street, Hiranandani Gardens, Powai,
Mumbai - 400076

{ 25700030
{ 25702715

Branches : AHMEDABAD, BENGALURU, BHOPAL, BHUBANESHWAR, CHANDIGARH, CHENNAI, COIMBATORE, DEHRADUN, DELHI, FARIDABAD, GHAZIABAD, GUWAHATI, HARYANA (CHANDIGARH), HUBLI, HYDERABAD, JAIPUR, JAMMU, JAMSHEDPUR, KOCHI, KOLKATA, LUCKNOW, MADURAI, MUMBAI, NAGPUR, NOIDA, PARWANOO, PATNA, PUNE, RAIPUR, RAJKOT, SURAT, VIJAYAWADA.