

उर्वरक एवं रासायनिक अंतःक्षेपण प्रणाली  
भाग 1 वेंचुरी अंतःक्षेपक — विशिष्टि  
( पहला पुनरीक्षण )

Fertilizer and Chemical Injection  
System  
Part 1 Venturi Injector — Specification  
( First Revision )

ICS 65.060.35

© BIS 2024



भारतीय मानक ब्यूरो  
BUREAU OF INDIAN STANDARDS  
मानक भवन, 9 बहादुर शाह ज़फर मार्ग, नई दिल्ली - 110002  
MANAK BHAVAN, 9 BAHADUR SHAH ZAFAR MARG  
NEW DELHI - 110002  
[www.bis.gov.in](http://www.bis.gov.in) [www.standardsbis.in](http://www.standardsbis.in)

## FOREWORD

This Indian Standard (Part 1) (First Revision) was adopted by the Bureau of Indian Standards, after the draft finalized by the Farm Irrigation and Drainage Systems Sectional Committee had been approved by the Food and Agriculture Division Council.

The application of fertilizer materials or/and other chemicals through irrigation water to crops/plants is based on the principle that a swiftly moving stream of water is able to carry with it the dissolved substances and fine dispersed suspended particles of fertilizer material. Venturi injector is one of the appliances used for this purpose.

Venturi injector operates on the principle that, when a pressurized operating (motive) fluid enters the injector, it is constricted towards the injection chamber and changes into a high velocity jet stream. The increase in velocity inside the injection chamber results in decrease in pressure, thereby enabling an additive liquid material to be drawn through the suction port and entrained into the motive stream. As the jet stream is diffused toward the injector outlet, its velocity is reduced and there will be a pressure drop at the outlet.

In order to standardize the requirements of this appliance for the benefit of manufacturers as well as users this standard was published first published in 1997. The revision of this standard has been brought to incorporate necessary editorial changes and to bring it out in the latest style and format of Indian Standards. Along with this, illustration of venturi injector with booster pump has been added.

The standard is published in 3 parts. The other two parts are:

- Part 2 Water-driven chemical injector pump — Specification
- Part 3 Fertilizer tank — Specification

The figures given in the standard are only for illustrations showing typical installation of venturi injectors in the main line.

The composition of the Committee responsible for the formulation of this standard is given in [Annex A](#).

For the purpose of deciding whether a particular requirement of this standard is complied with the final value observed or calculated expressing the result of a test or analysis, shall be rounded off in accordance with IS 2 : 2022 'Rules for rounding off numerical values (*second revision*)'. The number of significant places retained in the rounded off value should be the same as that of the specified value in this standard.

*Indian Standard***FERTILIZER AND CHEMICAL INJECTION SYSTEM****PART 1 VENTURI INJECTOR***( First Revision )***1 SCOPE**

This standard (Part 1) prescribes the requirements of venturi injectors used for injecting fertilizer and chemicals in the sprinkler and drip irrigation systems.

**2 REFERENCE**

The standards given below contain provisions which, through reference in this text, constitute provisions of this Indian Standard. At the time of publication, the editions indicated was valid. All standards are subject to revision, and parties to agreements based on this standard are encouraged to investigate the possibility of applying the most recent edition of this standard:

<i>IS No.</i>	<i>Title</i>
IS 2500 (Part 1) : 2000/ISO 2859-1 1999	Sampling procedures for inspection by attributes: Part 1 Sampling schemes indexed by acceptance quality limit (AQL) for lot- by-lot inspection ( <i>third revision</i> )

**3 TERMINOLOGY**

For the purpose of this standard the following definitions shall apply.

**3.1 Check Valve or Non-Return Valve** — A valve which permits flow in one direction only and prevents reversal of flow by means of an automatic check mechanism. The valve opens by the flow of liquid and closes by the weight of the check mechanism or mechanical pressure (for example, spring) when the flow ceases.

**3.2 Flow Control Device** — A device used for controlling or adjusting the flow by which pressure difference is created between the inlet and outlet.

**3.3 Injector Efficiency** — The ability to create a vacuum with minimal differential pressure (P).

**3.4 Maximum Flow Rate,  $Q_{max}$**  — The highest flow rate at the inlet to the pump which is permitted by the manufacturer for its operation.

**3.5 Maximum Operator Pressure,  $P_{max}$**  — Maximum pressure allowed at the inlet of injector assembly expressed in head of water column in metres or kPa.

**3.6 Minimum Flow (Optimal),  $Q_{min}$**  — The lowest now rate at the inlet to the pump at which the pump begins to operate normally as a function of the pressure at the inlet and the suction flow rate.

**3.7 Minimum Operating Pressure,  $P_{min}$**  — Minimum water pressure at the outlet of the injector assembly required to operate the injection system, often termed as outlet pressure expressed in head of water column in metres or kPa.

**3.8 Metering Device** — A device for adjusting the flow of chemical and additive solution drawn through the venturi injector's suction port during operation and thus calibrates the rate of dosing or injection.

**3.9 Motive Flow** — Rate of flow of motive fluid through the venturi injector measured at the inlet and expressed in 1/h.

**3.10 Nominal Size** — A conventional numerical designation used to indicate the inlet and outlet size of the venturi injector. This designation equals the nominal size of the pipe to which the venturi injector can be connected without intermediate fittings.

**3.11 Pressure Reducing Device** — A device which operates manually or automatically to create a pressure difference between the inlet and outlet.

**3.12 Suction Operation Range for Venturi Injection Systems** — The difference between the maximum operating pressure and minimum operating water pressure.

**3.12.1 Percentage of Injection Efficiency** — The suction operating range for venturi injection system divided by maximum operating pressure and multiplied by hundred.

**3.13 Suction Port** — The port of the venturi injector body through which chemical or additive solution is drawn into the venturi injector.

To access Indian Standards click on the link below:

[https://www.services.bis.gov.in/php/BIS\\_2.0/bisconnect/knownyourstandards/Indian\\_standards/isdetails/](https://www.services.bis.gov.in/php/BIS_2.0/bisconnect/knownyourstandards/Indian_standards/isdetails/)

**3.14 Suction Rate** — Rate at which the chemicals or other additive solutions are drawn into the venturi injector through the suction port during operation expressed in l/h.

**3.15 Venturi Injector** — An appliance used for fertigation or chemigation, chlorinating or injecting other chemicals in the sprinkler and drip irrigation systems.

**3.16 Venturi Injector Inlet** — Side through which the motive fluid enters the venturi injector body.

**3.17 Venturi Injector Outlet** — Side through which the motive fluid mixes with chemicals or other additives flows out.

## 4 MATERIAL

**4.1** The venturi injector parts that are in contact with water shall be of non-toxic materials and shall be resistant to or protected against degradation caused by operating conditions and types of water, chemicals or other additive solutions used in agricultural irrigation or used for cleaning the system.

**4.2** The venturi injector body and other parts shall also be resistant to environmental factors like ultraviolet radiation, peak outdoor temperature, corrosion, etc.

## 5 CONSTRUCTIONAL REQUIREMENTS

**5.1** The construction of venturi injector shall be such that proper installation in its intended location is feasible. It should be easily detachable for removal when not in use as a precautionary measure against theft or vandalism.

**5.2** Suction port shall have suitable connection preferably barbed type to connect suction pipe made of soft and flexible plastic.

**5.3** An inbuilt check valve (*see 3.1*) may be provided in the suction port to prevent entering of water from the main stream to the chemical or fertilizer.

**5.4** A metering device (*see 3.8*) shall be provided in the suction hose for adjusting the flow of chemicals through the suction port.

**5.5** A suction kit assembly comprising of non-collapsible and flexible plastic hose of suitable length and a suction strainer made of non-corrosive material shall be provided. Suction strainer may be fitted to the suction hose pipe with the help of barbed connection or quick coupling attachment.

**5.6** A pressure reducing device or flow control valve is provided on the main line between the inlet and outlet connections.

## 6 TESTS

All tests shall be performed with water or test liquid wherever specified at a temperature  $27\text{ }^{\circ}\text{C} \pm 3\text{ }^{\circ}\text{C}$ . The accuracy of instruments used for measuring various parameters shall be within  $\pm 2$  percent of the actual values.

### 6.1 Resistance of Venturi Injector to Internal Hydrostatic Pressure

This test shall be performed on the venturi injector with all its parts assembled for normal operation. Close the outlet of the venturi injector by suitable means. Inject water at pressure through the inlet. Raise the pressure gradually to 1.6 times the declared maximum operating pressure and maintain it for one minute.

The venturi injector shall withstand the test pressure without suffering damage or deformation.

### 6.2 Performance Test

Install the venturi injector on a by-pass line connecting main system flow pipeline (*see Fig. 1*). Create pressure difference between the inlet and the outlet with the help of pressure reducing device or flow control valve. Water suction should be measured at zero lift.

Measure the followings and cross check with the data supplied by the manufacturer. A variation of  $\pm 10$  percent shall be accepted from the declared values.

- a) The test liquid shall be water. The manufacturer shall declare the value with water as injecting liquid the manufacturer shall provide a separate table showing the change in suction rate as per density of stock solution; and
- b) Minimum pressure drop at which the liquid fluid (water) is drawn through the suction port in relation to inlet pressure specified by the manufacturer.

## 7 SAMPLING AND ACCEPTANCE

### 7.1 Type Test

The samples shall be selected at random from a total of minimum 50 venturi injectors. The number of test

specimens required for each test shall be as specified in [Table 1](#).

If the number of defective specimens in the sample does not exceed the acceptance number specified in [Table 1](#), the sample shall be considered as complying with the requirements of this standard. If the number of defective specimens in the sample is greater than the acceptance number, the sample shall be considered as not complying with the requirements of this standard.

## 7.2 Acceptance Test

When acceptance of manufacturing lot or shipment is required, the sampling shall be done according to IS 2500 (Part 1), based on AQL 2.5 and special inspection level S-4.

If the number of defective specimens in the sample does not exceed the acceptance number specified in IS 2500 (Part 1) the lot or shipment shall be considered as acceptable. If the number of defective specimens in the sample is greater than the acceptance number, the lot or shipment shall be rejected.

## 8 MARKING

**8.1** Each venturi injector shall bear a readily visible durable marking including following particulars:

- a) Name of manufacturer and/or his registered trademark;
- b) Model identification;
- c) Nominal size;
- d) Maximum operating pressure; and
- e) Arrow mark to indicate the direction of motive flow.

## 8.2 BIS Standard Marking

The product(s) conforming to the requirements of this standard may be certified as per the conformity assessment schemes under the provisions of the *Bureau of Indian Standards Act, 2016* and the Rules and Regulations framed thereunder, and the products may be marked with the Standard Mark.

## 9 INFORMATION TO BE SUPPLIED BY THE MANUFACTURER

The manufacturer shall supply the following information about the venturi injector:

- a) Name and address of manufacturer;
- b) Model and catalog number of venturi injector;
- c) Venturi injector performance data:
  - 1) Table showing motive flow and liquid suction at various differential pressures;
  - 2) Minimum differential pressure between inlet and outlet for working of the venturi injector;
  - 3) Maximum safe operating pressure at the inlet;
  - 4) Type of connection to piping network;
  - 5) Instructions for assembly and operation;
  - 6) List of spare parts; and
  - 7) Resistance to chemicals commonly used during irrigation as well as cleaning.

**Table 1 Sampling for Type Testing**

(Clause [7.1](#))

Sl No.	Clause	Nature of Test	No. of Test Specimens	Acceptance Number
(1)	(2)	(3)	(4)	(5)
i)	<a href="#">6.1</a>	Resistance of venturi injector to internal hydrostatic pressure	5	0
ii)	<a href="#">6.2</a>	Performance test	5	0

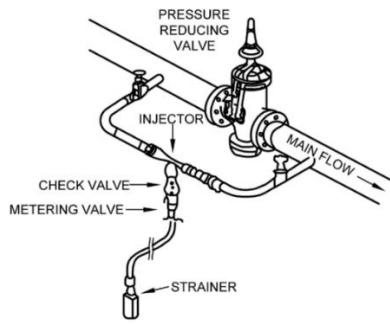

FIG. 1A A REGULAR VALVE INSTALLED IN BETWEEN THE INLET AND OUTLET CONNECTIONS OF THE VENTURI INJECTOR CREATES DIFFERENTIAL PRESSURE AND FINALLY VACUUM NEAR TEE SUCTION PORT

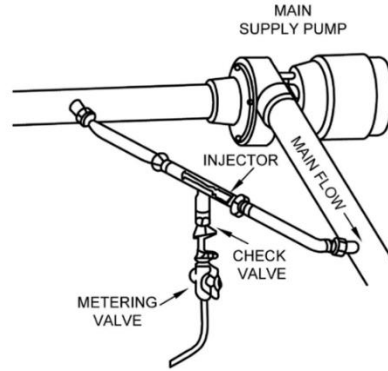

FIG. 1B INLET OF THE VENTURI CONNECTED TO THE SUCTION PIPE OF A PUMP AND THE OUTLET CONNECTED TO THE DELIVERY PIPE OF THE PUMP. PRESSURE DIFFERENTIAL IS CREATED AUTOMATICALLY WHEN THE PUMP STARTS RUNNING

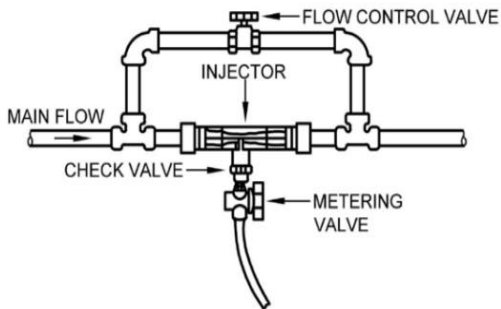

FIG. 1C INJECTOR CAN BE INSTALLED DIRECTLY IN THE MAIN LINE WITH A BY-PASS CONNECTION HAVING FLOW CONTROL VALVE. WHEN INJECTION IS NOT REQUIRED MAIN FLOW CAN BE DIVERTED THROUGH THE BY-PASS IN TO THE SYSTEM

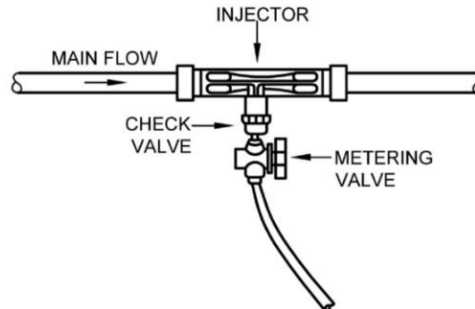

FIG. 1D INSTALLED IN THE MAIN FLOW LINE, TOTAL FLOW OF THE SYSTEM GOES THROUGH THE INJECTOR

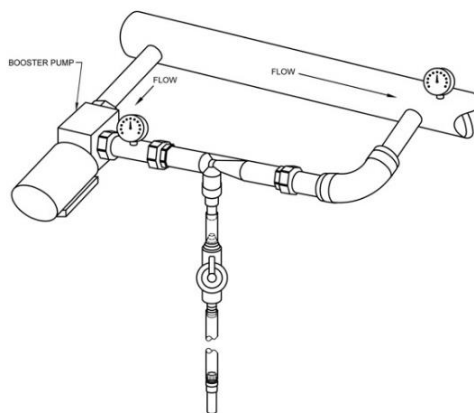

FIG. 1E VENTURI INJECTOR WITH BOOSTER PUMP

FIG. 1 ILLUSTRATIONS SHOWING TYPICAL INSTALLATIONS OF VENTURI INJECTOR

## ANNEX A

*(Foreword)*

## COMMITTEE COMPOSITION

Farm Irrigation and Drainage Systems Sectional Committee, FAD 17

<i>Organization</i>	<i>Representative(s)</i>
In Personal Capacity ( <i>D-26, Pusa Campus, Agricultural Research Institute, New Delhi - 110012</i> )	DR T. B. S. RAJPUT ( <b><i>Chairperson</i></b> )
Automat Industries Private Limited, New Delhi	SHRI DINESH KUMAR SHRI NAWAL KISHORE SHAH ( <i>Alternate</i> )
CIPET, Chennai	DR SANDESH KUMAR JAIN SHRI VISHAL VERMA ( <i>Alternate</i> )
Dr Y.S. Parmar University of Horticulture and Forestry, Solan	PROF RAJESHWAR SINGH CHANDEL SHRI SUDHIR VERMA ( <i>Alternate</i> )
Finolex Plasson Industries Limited, Pune	SHRI VIJAY JADHAV SHRI BAJIRAO BHOSALE ( <i>Alternate</i> )
Gujarat Green Revolution Company Limited, Vadodara	DR ASHUTOSH VASANT VADAWALE SHRI R. V. LIMBASHIA ( <i>Alternate I</i> ) SHRI HARDIK PANCHOLI ( <i>Alternate II</i> )
ICAR - Central Institute of Agricultural Engineering, Bhopal	DR RANJAY KUMAR SINGH DR YOGESH A. RAJWADE ( <i>Alternate</i> )
ICAR - Central Soil Salinity Research Institute, Karnal	DR DEVENDRA SINGH BUNDELA DR SATYENDRA KUMAR ( <i>Alternate</i> )
Indian Council of Agricultural Research, New Delhi	DR KONDAPALLY V. RAMANARAO
Jain Irrigation Systems Limited, Jalgaon	SHRI SUNIL LODHA SHRI ABHIJEET B. JOSHI ( <i>Alternate</i> )
Mahatma Phule Krishi Vidyapeeth, Rahuri	DR SACHINKUMAR NANDGUDE DR SHRIMANT RAHOD ( <i>Alternate</i> )
Mahindra EPC Irrigation Limited, Nashik	SHRI RAJEEV DESHPANDE SHRI ASHISH KUMAR ( <i>Alternate</i> )
National Committee on Precision Agriculture and Horticulture, New Delhi	SHRI ANAND ZAMBRE SHRI ROHIT LALL ( <i>Alternate</i> )
Netafim Irrigation Private Limited, Vadodara	SHRI SETHURAMALINGAM S. SHRI MANISH KUMAR PATEL ( <i>Alternate</i> )
Nimbus Pipes Limited, Jaipur	SHRI ASHISH KUMAR LATH SHRI HARIDWAR TIWARI ( <i>Alternate</i> )
NITI Aayog, New Delhi	DR NEELAM PATEL SHRIMATI ANURADHA BATANA ( <i>Alternate</i> )
Premier Irrigation Adritec Limited, Nagpur	SHRI A. K. PRADHAN SHRI G. K. KUMAR ( <i>Alternate</i> )
Punjab Agricultural University, Ludhiana	DR J. P. SINGH DR SUNIL GARG ( <i>Alternate</i> )
Reliance Industries Limited, Mumbai	SHRI AMIT SHAH
Rivulis Irrigation India Private Limited, Vadodara	SHRI GOPI KETHAVATH
Saurashtra Plastics Manufacturer's Association, Rajkot	SHRI ARUN ROKAD SHRI J. K. PATEL ( <i>Alternate I</i> ) SHRI BHARAT KUMAR V. SIROYA ( <i>Alternate II</i> )

**IS 14483 (Part 1) : 2024**

<i>Organization</i>	<i>Representative(s)</i>
School of Agriculture, Indira Gandhi National Open University, New Delhi	DR MUKESH KUMAR
Visvesvaraya Technological University (VTU), Belgavi	DR NAGRAJ S. PATIL
Water Technology Centre, ICAR - Indian Agricultural Research Institute, New Delhi	DR ANIL KUMAR MISHRA DR SUSAMA SUDHISHRI ( <i>Alternate</i> )
BIS Directorate General	SHRIMATI SUNEETI TOTEJA, SCIENTIST 'F'/SENIOR DIRECTOR AND HEAD (FOOD AND AGRICULTURE) [REPRESENTING DIRECTOR GENERAL ( <i>Ex-officio</i> )]

*Member Secretary*  
SHRI VIKRANT CHAUHAN  
SCIENTIST 'B'/ASSISTANT DIRECTOR  
(FOOD AND AGRICULTURE), BIS

Panel to Review Indian Standards on Micro-Irrigation Component, FAD17/P 2

<i>Organization</i>	<i>Representative(s)</i>
Visvesvaraya Technological University (VTU), Belgavi	DR NAGRAJ S. PATIL ( <i>Convener</i> )
Finolex Plasson Industries Limited, Pune	SHRI BAJIRAO BHOSALE
Jain Irrigation Systems Limited, Jalgaon	SHRI SUNIL LODHA SHRI ABHIJEET B. JOSHI ( <i>Alternate</i> )
Mahindra EPC Irrigation Limited, Nashik	SHRI RAJEEV DESHPANDE SHRI ASHISH KUMAR ( <i>Alternate</i> )
National Committee on Precision Agriculture and Horticulture, New Delhi	SHRI ROHIT LALL
Netafim Irrigation Private Limited, Vadodara	SHRI SETHURAMALINGAM S.
Premier Irrigation Adritec Limited, Nagpur	SHRI G. K. KUMAR





## Bureau of Indian Standards

BIS is a statutory institution established under the *Bureau of Indian Standards Act, 2016* to promote harmonious development of the activities of standardization, marking and quality certification of goods and attending to connected matters in the country.

### Copyright

BIS has the copyright of all its publications. No part of these publications may be reproduced in any form without the prior permission in writing of BIS. This does not preclude the free use, in the course of implementing the standard, of necessary details, such as symbols and sizes, type or grade designations. Enquiries relating to copyright be addressed to the Head (Publication & Sales), BIS.

### Review of Indian Standards

Amendments are issued to standards as the need arises on the basis of comments. Standards are also reviewed periodically; a standard along with amendments is reaffirmed when such review indicates that no changes are needed; if the review indicates that changes are needed, it is taken up for revision. Users of Indian Standards should ascertain that they are in possession of the latest amendments or edition by referring to the website-[www.bis.gov.in](http://www.bis.gov.in) or [www.standardsbis.in](http://www.standardsbis.in).

This Indian Standard has been developed from Doc No.: FAD 17 (24677).

### Amendments Issued Since Publication

Amend No.	Date of Issue	Text Affected

## BUREAU OF INDIAN STANDARDS

### Headquarters:

Manak Bhavan, 9 Bahadur Shah Zafar Marg, New Delhi 110002

Telephones: 2323 0131, 2323 3375, 2323 9402

Website: [www.bis.gov.in](http://www.bis.gov.in)

### Regional Offices:

Central : 601/A, Konnectus Tower -1, 6<sup>th</sup> Floor,  
DMRC Building, Bhavbhuti Marg, New  
Delhi 110002

Telephones

{ 2323 7617

Eastern : 8<sup>th</sup> Floor, Plot No 7/7 & 7/8, CP Block, Sector V,  
Salt Lake, Kolkata, West Bengal 700091

{ 2367 0012  
{ 2320 9474

Northern : Plot No. 4-A, Sector 27-B, Madhya Marg,  
Chandigarh 160019

{ 265 9930

Southern : C.I.T. Campus, IV Cross Road, Taramani, Chennai 600113

{ 2254 1442  
{ 2254 1216

Western : 5<sup>th</sup> Floor/MTNL CETTM Technology Street, Hiranandani Gardens, Powai,  
Mumbai - 400076

{ 25700030  
{ 25702715

**Branches :** AHMEDABAD, BENGALURU, BHOPAL, BHUBANESHWAR, CHANDIGARH, CHENNAI, COIMBATORE, DEHRADUN, DELHI, FARIDABAD, GHAZIABAD, GUWAHATI, HARYANA (CHANDIGARH), HUBLI, HYDERABAD, JAIPUR, JAMMU, JAMSHEDPUR, KOCHI, KOLKATA, LUCKNOW, MADURAI, MUMBAI, NAGPUR, NOIDA, PARWANOO, PATNA, PUNE, RAIPUR, RAJKOT, SURAT, VIJAYAWADA.