खेत के जल निकासी पम्पिंग संयंत्र की
संस्थापन और डिज़ाइन — रीति संहिता
(पहला पुनरीक्षण)

**Design and Installation of Farm
Drainage Pumping Plants — Code of
Practice**
(*First Revision*)

ICS 65.040.35

© BIS 2024



भारतीय मानक ब्यूरो
BUREAU OF INDIAN STANDARDS
मानक भवन, 9 बहादुर शाह ज़फर मार्ग, नई दिल्ली - 110002
MANAK BHAVAN, 9 BAHADUR SHAH ZAFAR MARG
NEW DELHI - 110002
www.bis.gov.in www.standardsbis.in

August 2024

Price Group 7

FOREWORD

This Indian Standard (First Revision) was adopted by the Bureau of Indian Standards, after the draft finalized by the Farm Irrigation and Drainage Systems Sectional Committee had been approved by the Food and Agriculture Division Council.

This standard was first published in 1986 to provide principles and practices useful to engineers in the planning and design of pumping plants for drainage of farmland. In preparation of this standard, assistance was taken from ASAE EP 369-1974 'Design of agricultural drainage pumping plants,' issued by the American Society of Agricultural Engineers, USA.

The revision of this standard has been brought out to update the standard with current technological practices. The following major modifications have been made:

- a) Different types of pumps which may be used in the pumping plants have been incorporated;
- b) For safe and efficient working of pumping plant, guidelines for usage of sensors and automatic shutoff mechanism along with methods of flow measurement have been added;
- c) Record keeping for operation and maintenance of pumping plant has also been added; and
- d) Necessary editorial changes have been made including updating of referred Indian Standards and schematic diagrams given in the standard.

In revising the standard considerable assistance has been derived from the inputs provided by Punjab Agricultural University, Ludhiana.

The composition of the Committee responsible for the formulation of this standard is given in [Annex A](#).

For the purpose of deciding whether a particular requirement of this standard is complied with, the final value, observed or calculated, expressing the result of a test or analysis, shall be rounded off in accordance with IS 2 : 2022 'Rules for rounding off numerical values (*second revision*)'. The number of significant places retained in the rounded off value should be the same as that of the specified value in this standard.

*Indian Standard***DESIGN AND INSTALLATION OF FARM DRAINAGE
PUMPING PLANTS — CODE OF PRACTICE***(First Revision)***1 SCOPE**

This standard covers the guidelines for design and installation of pumping plants for farm drainage purposes.

NOTE — This standard does not cover the pumping plant for deep well drainage.

2 REFERENCES

The standards listed in [Annex A](#) contain provisions, which through references in this text constitute provisions of this standard. At the time of publication, the editions indicated were valid. All standards are subject to revision and parties to agreements based on this standard are encouraged to investigate the possibility of applying the most recent edition of these standards.

3 CLASSIFICATION OF WATER STORAGE SYSTEM

Water storage system for pumping plants shall be classified as follows:

- a) Open storage tank — for collecting and temporarily storing both surface and ground water; and
- b) Sumps — for storing ground water only.

NOTE — Under the monsoonic rainfall situation, surface drainage component would be much more than the subsurface one. On the other hand, during post monsoon period, pumping requirement would essentially consist of subsurface component and capacity of pumps would be much lower. A drainage pumping plant under such situation would require design of two pumping plants; larger one to meet monsoon requirement and smaller one for post monsoon period.

4 PLANNING OF AREA TO BE PUMP DRAINED

4.1 The drainage system of the area served by the pumping plants should be planned to meet both drainage needs of the area as well as efficient operation of the pumps.

4.1.1 Runoff from high ground, when removable by gravity flow to a suitable outlet, should be excluded from the pumped area by diversion around the area or by channeling through the area.

4.1.2 Protection of pumped area against overflow or back water from the outlet should be provided by perimeter dikes designed against overtopping, wave action, erosion and instability of high water stages. Direct disposal of stored water by gravity in the storage reservoir could be made by the pipe outlets through the embankment. These outlets should be protected by gates to prevent backflow during the high exterior water stages and permit outflow during low water stages. This would reduce load on pumping system.

4.1.3 The drainage system of the pumped area should provide the following:

- a) An optimum storage tank/sump water stage commensurate with the designed depth of water table;
- b) In case of surface drainage system, use of undeveloped swamp or lowland near or adjoining the pumping plant to supplement tank/sump water storage for reduction of the pumping rate; and
- c) Drainage channels discharging water to the water tank/sump should be suitably designed to avoid channel scouring.

4.1.4 Pumping plant location should be at or near the point of lowest elevation of the pumped area and accessible to an adjacent outlet. Site adjustments should be made as necessary to provide foundations without excessive use of piling, freedom from flooding of operating equipment, ready access to fuel or power supply and protection from vandalism.

4.2 The outlet channel from the pumped area shall be adequate for handling the discharge. If it is to discharge in an irrigation canal system, the applicable statutory requirements should be followed.

5 PUMPING PLANT CAPACITY

5.1 The pumping rate and frequency should be determined from the drainage requirement and temporary storage.

5.1.1 The drainage requirement would vary with climate, topography, soils, and land use, types of crops and cost effectiveness of the system. Such

requirements may be expressed as a coefficient or quantity of water to be removed per unit of area per unit of time. Drainage coefficient should be computed on the basis of local data (see also 4 of IS 10907).

5.1.2 Pumping plant capacity for surface and/or subsurface drainage should be based on surface and/or subsurface drainage designed coefficients respectively.

6 PUMP SELECTION AND INSTALLATION

6.1 The selection of the drainage pump would usually be based on designed discharge and total head as well as type of power available.

6.2 Pump performance varies with head, speed, discharge and power relationships. The effect of these factors on efficiency of the pumping operation may be obtained from pump manufacturer's performance curves or pump characteristics for each kind and size of pump made.

Cavitation is caused as a result of absolute pressure dropping below the vapour pressure of the liquid which passes through suction and impeller inlet. It results in pump vibration and noise, reduces pump discharge and efficiency and causes pump deterioration. Performance curves are useful for guidance in making proper selection and to ensure proper operation without cavitation. These curves would help to avoid the following at the time of pump selection:

- a) Heads much higher or lower than those at optimum efficiency;
- b) Capacities much lower than capacity at peak efficiency;
- c) Suction lifts abnormally higher, or net positive suction heads (NPSH) lower than the rated for the pump; and
- d) Speeds higher than those recommended for the pump.

6.3 Total head (H_t) is sum of static head (H), velocity head (H_v) and friction head (H_f) and is total energy that a pump should impart at designed discharge.

6.3.1 Static head or lift, is the vertical distance between the free water surface at the suction side of the pump and the free water surface at the discharge pipe side of the pump when discharge pipe is submerged, or at the centre of the discharge pipe when discharge pipe is not submerged. For the purpose of designing, H is to be considered from the

lowest level on the suction side to the highest water level on the discharge pipe side.

6.3.2 Velocity head (H_v) in m, for various pump sizes and capacities can be calculated as follows:

$$H_v = \frac{V^2}{2g} = 0.083 \frac{Q^2}{D^4}$$

where

V = column velocity at discharge end, m/s;

Q = pump capacity, m³/s;

g = acceleration due to gravity; and

D = Diametre.

6.3.3 When water or any other liquid moves through a pipe line, the latter offers some resistance to the flow. This resistance depends on the diameter, length, type and condition of the pipe and its fittings and velocity of flow. The values of head loss due to friction in pipes may be obtained on the basis of IS 2951 (Part 1). Head loss due to friction for PVC pipes may be obtained from the supplier.

When calculating pipe losses allowances should be included for tees, bends, valves, and other fittings and obstructions in a particular pipe line. The values can be obtained from IS 2951 (Part 2) and added to the value obtained for straight pipes (see [6.3.3](#)).

6.4 Size of pump (diameter of the discharge pipe at the pump outlet) can be calculated on the basis of the following formula:

$$D = 1.13 \frac{Q^{1/2}}{V}$$

where

D = size of the pump, m;

Q = pump capacity, m³/s; and

V = column velocity, m/s.

The column velocity of a pump may range between 2.0 m/s to 3.7 m/s, however 3 m/s may be used as an initial estimate in developing the pumping plant design.

6.5 The discharge pipe should be of adequate capacity and water tight.

6.5.1 The discharge pipe may be gradually enlarged away from the pump by several pipe sizes to decrease velocity head and thereby decrease the power cost.

NOTE — The friction losses in the discharge pipe can be reduced greatly by use of larger diameter pipe, usually 5 cm

to 15 cm larger than the pump discharge flange. The transition can be made through a short expanding section of pipe at the pump flange, usually over a length of 60 cm (see Fig. 1).

6.5.2 Submerged discharges are recommended to keep heads as low as possible. A non-return or flap valve should be used at the pipe end to prevent backflow through the pump. Erosion Protection from discharging water should be considered when out letting into an earthen channel.

6.5.3 A siphon may be used whenever drainage water is pumped over a dike for both reductions in total head and reduction in power cost.

6.5.3.1 Priming head shall be greater than operating head. The pump should be able to deliver a full cross section of water over the crest at a velocity over 1.5 m/s. However, a limit on maximum lift of the siphon and maximum velocity of flow at the crest should be maintained to prevent reducing inside pressure at the crest to avoid cavitation. Discharge pipe should be sufficiently submerged to prevent air entrainment. The pipe section at the crest should have sufficient strength to resist external atmospheric pressure.

6.5.3.2 A siphon breaker shall be installed at the highest point in pipeline to prevent reverse flow during a power interruption (see Fig. 2). The siphon breaker would be actuated when power stops or flow reverses. The non-return flap valve at the end of the discharge pipe may serve in lieu of a siphon breaker for small pumping plants.

6.5.3.3 An air release valve is required to ensure smooth priming of the siphon. This is preferably installed at the top of the bend outlet of the discharge pipe and near the water surface.

6.6 Typical drainage pump installations and head relationships that should be considered in their design is shown in Fig. 2. For installation, guidance may be taken from IS 9694 (Part 2).

7 STORAGE

7.1 The volume of drainage runoff to be stored in the tank/sump and auxiliary areas will vary from a maximum expected total runoff of the designed storm to a minimum set by the pumping rate that would prevent excessive numbers of pump starts and stops by the power source.

7.2 For manual operation of the pumps, pump starts may be limited to two per day for convenience of the operator. The volume of storage for two starts per day should be calculated on the basis of following formula:

$$S = 11235Q$$

where

S = volume of storage, m^3 ; and

Q = pump capacity, m^3/s .

7.3 For automatic operation of pumps, cycles of operation should be limited to about 10 per h. This occurs when inflow is equal to one-half of the pump capacity. Minimum storage may be calculated as follows:

$$S = 90Q$$

where

S = volume of storage, m^3 ; and

Q = pump capacity, m^3/s .

8 TANK/SUMP DESIGN

8.1 The shape, size and position of the storage tank/sump with respect to the pump affect the efficiency of the pumping operation.

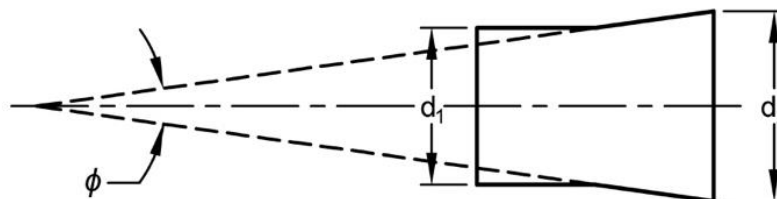

FIG. 1 DIAGRAM INDICATING USE OF LARGER PIPE TO REDUCE FRICTION LOSS

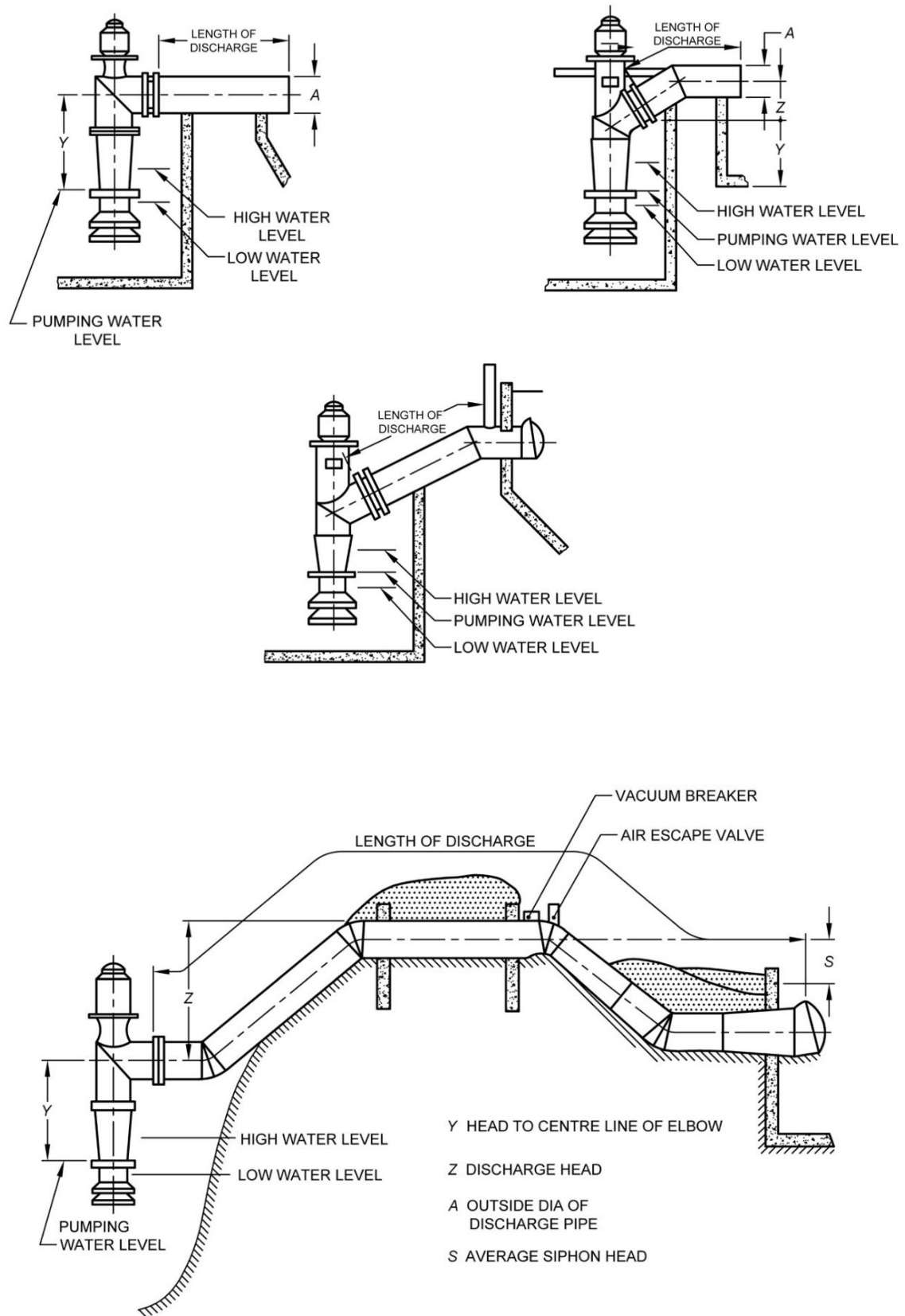

FIG. 2 TYPICAL DRAINAGE PUMP INSTALLATION

8.2 Efficient pump operation requires special sump dimensions and pump clearance for smooth free flow of water in the suction intake pipe. Essential clearances are shown in Fig. 3. Sump water level should be maintained above a minimum submergence of the pump suction intake and is determined by the greater of the following independent conditions:

- a) Water cover over the propeller should be sufficient to keep the pump self-priming;
- b) Net positive suction head (NPSH) should be as determined by the pump manufacturer to overcome cavitation; and
- c) Submergence, as usually recommended in manufacturers' literature for vortex suppression, determined approximately from the following formula, is maintained:

$$K = \frac{2Q}{\pi d^2}$$

where

K = minimum submergence, m;

Q = pump capacity, m³/s; and

d = pump suction bell diameter, m.

- d) Water storage capacity should be sufficient to prevent too frequent pump starts and stops.

8.2.1 Sump dimensions for automatic operation can be varied to fit field condition and be in line with economical installation. Generally, the sump should not be deep but large and shallow. For efficient automatic operation, storage depth of sump of 0.7 m to 1.0 m below the bottom of the pump is recommended. Greater sump storage depth usually adds to both installation and operation costs of the pumping plant. In some soils, wide and frequent fluctuations in water depth cause serious bank sloughing and channel erosion.

8.2.2 In case of large circular sump, rotational effect can be minimized by placing the pump near the wall.

8.2.3 Floor of the approach channel and sump should be level for a distance of 5 times of diameters of the suction bell measured from the centerline of the pump. Approach velocity to the pump should be kept to 0.3 m/s unless the sump configuration has been checked for eddy currents by the manufacturer. Trash rack openings below minimum static water level should permit water passage at designed velocity.

8.2.4 Side wall clearance of pumps should not be less than 24 times the diameter of the suction bell.

8.2.5 Minimum clearance between adjacent pump centerlines should be the sum of the diameters of the suction bells.

8.2.6 Back wall clearance of pumps may be reduced to that necessary for maintaining the pumps.

8.2.7 Where ditch storage is provided, size of culvert inlet passing water to the sump should be sufficient to handle the maximum pump discharge at a velocity not exceeding 0.6 m/s.

8.2.8 Drain tile outlets discharging into a sump should be located as far from the pump as possible so as to minimize effect of turbulence and air entrainment.

9 PUMPS

The selection of the appropriate pump depends on factors such as the depth of the sump or tank, required flow rate, power source availability, and specific farm drainage needs. It's essential to choose a pump that matches the intended application to ensure efficient water lifting and optimal agricultural productivity. For lifting farm drainage water from a sump or tank, several types of pumps can be used, depending on the specific requirements and conditions of the farm. Here are some common pumps used for this purpose.

9.1 Submersible Pumps

Submersible pumps are designed to be submerged in water and are ideal for lifting water from sumps or tanks. They are efficient and require minimal priming. Submersible pumps are commonly used in both agricultural and domestic applications. For selection, installation of submersible pumps, guidance can be taken from IS 14536 and IS 8034.

9.2 Centrifugal Pumps

Centrifugal pumps are widely used in agriculture for various purposes, including lifting water from sumps and tanks. They work by converting rotational energy from a motor into kinetic energy to move water.

9.3 Diaphragm Pumps

Diaphragm pumps use a flexible diaphragm to move water, making them suitable for lifting water with solids or chemicals from sumps or tanks. They can handle some level of debris without clogging.

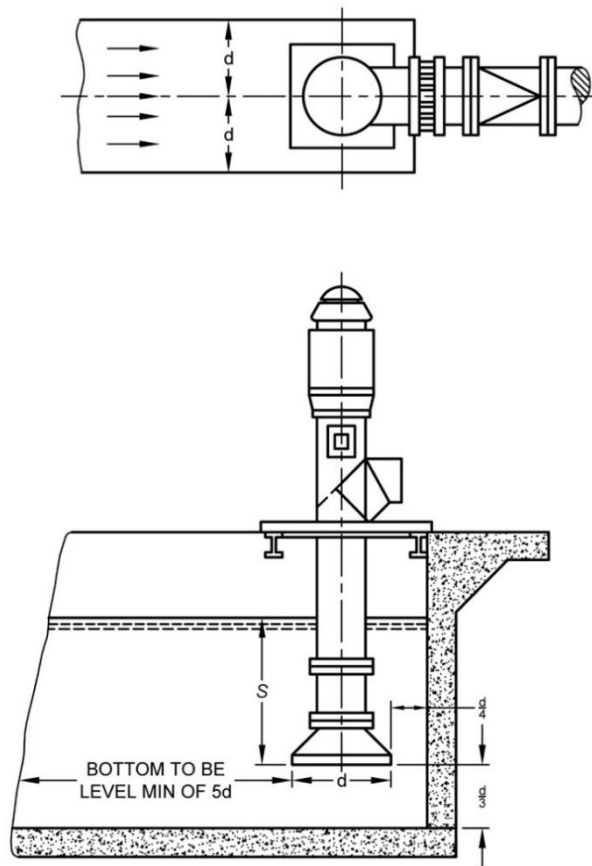

FIG. 3 RECOMMENDED SUMP CLEARANCES

9.4 Self-Priming Pumps

Self-priming pumps are capable of drawing water into the pump casing without the need for external priming. They are ideal for applications where the pump may be above the water level, such as lifting water from a shallow sump or tank.

9.5 Diesel Engine Pumps

Diesel engine pumps are used in areas without access to electricity. They can provide significant water flow rates and are suitable for lifting water from sumps or tanks in remote locations.

9.6 Solar-Powered Pumps

Solar-powered pumps are increasingly popular for their renewable energy source. They can be used to lift water from sumps or tanks, especially in areas with ample sunlight and a need for sustainable solutions [see IS 17018 (Part 1)].

10 POWER SOURCE

10.1 Driving units for pump may be electric motors, diesel, petrol or gas fueled engines. Electric motors

provide an economical installation when an adequate and reliable source of electric power is available close to the site at reasonable cost. Internal combustion engines should be used when the source of electric power is not reliable or is too costly. Use of alternate sources of energy like wind mills and solar energy should be considered wherever feasible.

10.2 Electric power is convenient for pump drainage operation and easily adapted to automatic operation. Motors and controls should conform to requirements of the relevant Indian Standards.

10.3 Diesel and petrol engines may be adapted for variation in speed over a broad range and are limited only by the range of critical speeds which produce dangerous torsional vibrations.

11 DRIVE HEADS

11.1 Drive heads are required to connect the power source to the pump. Loss of efficiency through these units range from none in direct connections to about 5 percent in gear connections, and up to 10 percent in multiple belt connections. Proper direction of

pump rotation should be maintained in all drive applications.

11.1.1 Direct connected hollow shaft electric motors are used in a vertical position.

11.1.2 A right angle gear drive is required to connect internal combustion engines to vertical pumps.

11.1.3 Multiple V-belt heads and flat pulley heads are suited to small pump installations.

12 SENSORS AND AUTOMATIC PUMP SHUTDOWN

The purpose of this clause is to ensure the safe and efficient operation of the pump while protecting it from potential damage due to water overflow or dry running. Adherence to these guidelines will help maintain the longevity of the pump and ensure optimal performance in farm drainage systems.

12.1 Sensor Installation

The pump shall be equipped with water level sensors installed in the sump or tank from where water is drawn. These sensors shall accurately measure the water level at predetermined intervals or in real-time.

12.2 Sensor Calibration and Maintenance

The water level sensors shall be calibrated regularly to ensure accurate readings. Maintenance and inspection of the sensors shall be conducted as per the manufacturer's recommendations to ensure their proper functioning.

12.3 Water Level Thresholds

Specific water level thresholds shall be defined based on the pump's safe operating range and the minimum required water level for efficient pumping. Two critical thresholds shall be established:

- a) 'High-level' threshold — When the water level rises above this threshold, indicating the sump is near capacity; and
- b) 'Low-level' threshold — When the water level falls below this threshold, indicating a potential risk of pump damage due to running dry.

12.4 Pump Shutdown Logic

The pump control system shall be programmed with a logical sequence for automatic shutdown based on

the water level readings from the sensors:

- a) If the water level exceeds the 'high-level' threshold, the pump shall automatically shut down to prevent overflow and potential damage to the pump and surrounding infrastructure; and
- b) If the water level falls below the 'low-level' threshold, the pump shall automatically shut down to prevent dry running, which can lead to pump damage and reduced efficiency.

12.5 Alarm and Notification System

The automatic shutdown system shall be integrated with an alarm and notification mechanism to alert the operator or farm manager of any abnormal water level conditions. This notification system can be in the form of visual alerts, audible alarms, or remote monitoring via a mobile app or web interface.

12.6 Restart Delay and Safety Checks

After the automatic shutdown is triggered, the pump shall not restart immediately. A predefined restart delay shall be implemented to allow time for the water level to stabilize. Additionally, safety checks shall be conducted before restarting the pump to ensure the sump conditions are safe and within the operational parameters.

12.7 Manual Override

The pump control system shall include a manual override option to allow authorized personnel to start or stop the pump independently, bypassing the automatic sensor-based shutdown when necessary.

13 SAFETY REQUIREMENTS FOR AUTOMATIC OPERATION

13.1 Automatic operation is used primarily with electrical power sources. Points to be considered in applying such equipment are given below:

- a) Evaluation of added installation and maintenance costs against advantages sought;
- b) Possible lack of interest on the part of owner or operator if operation is too much automated;
- c) Controls compatible with State Electricity rules;
- d) Possibility of moisture getting into or submergence of controls;

- e) Hazards of winter operation in cold climates; and
- f) Greater requirement of operator vigilance and maintenance including lubrication and trash rack cleaning.

13.2 Automatic controls are available for internal combustion engines such as an electric starting system for air cooled engines. Such systems are not readily adaptable to most pump installations.

13.3 Protective controls shall be supplied for all installations.

13.3.1 Automatic or electric units should have safety shut-off against overload, low voltage, and excessive heating.

13.3.2 Internal combustion engines should have controls which protect against overheating, low oil pressure and excessive speed.

13.3.3 Auxiliary warning devices, such as signal lights and siren on the pump house should be provided for attention of the owner or operator.

14 HOUSING

14.1 Type of housing for pumping plants depends upon importance and size of the plant, type of power used and plant location.

14.1.1 Factors influencing need for housing are air temperature, wind, humidity, precipitation and flooding fuel storage, safety, vandalism and plant appearance.

14.1.2 Materials used for housing should be fire resistant, waterproof, durable and easily maintained.

14.1.3 Size of housing should be sufficient for the containment and servicing of the equipment. Provision should be made for removing the pumps when required.

15 TRASH RACKS

15.1 Trash racks should be provided to prevent entry of floating debris/trash into sumps where damage to pumps might otherwise occur.

15.1.1 Trash racks should be set not less than 24 times the suction bell diameter in front of the centerline of the pumps.

15.1.2 Velocity of flow through the trash rack should not exceed 0.6 m/s.

15.1.3 Recommended trash rack bar spacing is as follows:

<i>Sl No.</i>	<i>Pump Diametre,</i> mm	<i>Bar Spacing,</i> mm
(1)	(2)	(3)
i)	Up to 400	20
ii)	450 to 600	25 to 38
iii)	760 to 1 060	50
iv)	1 060 and above	65 to 75

15.1.4 Trash racks should be sloped so that cleaning by hand is easily done or they should be equipped with mechanical cleaner.

15.1.5 Where trash racks are not feasible, galvanized basket strainers may be used on small pumps to prevent entry of small gravel and debris.

16 RECORD KEEPING

16.1.1 The purpose of recording data is to track operational information that will identify and avoid duplicating optimum operating conditions.

16.1.2 A record of equipment performance and repairs allow operation and maintenance personnel to properly evaluate equipment's effectiveness and determine if the equipment meets the objectives to justify its purchase and installation.

16.1.3 As a minimum, the following basic information should be maintained for each equipment in the pumping station:

- a) Plant equipment identification number;
- b) Manufacturer;
- c) Model number and serial number;
- d) Type;
- e) Dates of installation and removal from service;
- f) Reasons for removal;
- g) Location when installed;
- h) Calibration data and procedures;
- j) Hours required to perform maintenance;
- k) Cost of replacement parts;
- m) Operation and maintenance manuals, references and their locations; and

- n) Apparatus failure history inspection reports should be prepared for each sewage pumping station according to the equipment installed.

17 FLOW MEASUREMENT

Flow measurement for farm drainage pumping plants involves determining the volume of water passing through the system per unit of time. Accurate flow measurement is essential for efficient water management, crop irrigation, and drainage control. Several methods are commonly used for flow measurement in farm drainage pumping plants.

17.1 Water Meters

There are various types of water meters, including:

17.1.1 Mechanical Water Meters

These traditional meters use mechanical components, such as gears and turbines, to measure water flow. They are widely used in residential and commercial settings.

17.1.2 Ultrasonic Water Meters

These meters use ultrasonic technology to measure flow velocity and calculate water volume accurately. They are more advanced and suitable for various applications, including smart metering.

17.1.3 Magnetic Water Meters

Magnetic flow meters use Faraday's law of electromagnetic induction to measure the volume of conductive fluids like water.

17.2 Open Channel Flow Measurement

17.2.1 Weirs

V-notch weirs and rectangular weirs are common devices used to measure flow in open channels. The water level over the weir correlates with the flow rate.

17.2.2 Flumes

Parshall flumes and Palmer-Bowls flumes are structures placed in open channels to measure flow rates based on the water level and the geometry of the flume.

17.2.3 Turbine Flow Meters

Turbine flow meters have a rotor with blades that rotate as the fluid flows through the meter. The rotational speed of the blades is proportional to the flow rate, enabling flow measurement.

17.2.4 Water Level Sensors

Pressure transducers or ultrasonic level sensors can be used to measure the water level in tanks, sumps, or channels. By combining water level data with channel dimensions, the flow rate can be calculated.

17.2.5 Velocity-Area Method

In open channels, the flow rate can be estimated using the velocity-area method. This involves measuring the cross-sectional area of the channel and the velocity of the water.

ANNEX A

(Clause 2)

LIST OF REFERRED STANDARDS

<i>IS No.</i>	<i>Title</i>	<i>IS No.</i>	<i>Title</i>
IS 2951	Recommendation for estimation of flow of liquids in closed conduits:		Code of practice: Part 2 Installation (<i>first revision</i>)
(Part 1) : 1965	Head loss in straight pipes due to frictional resistance	IS 10907 : 1984	Code for design of farm drainage tile or pipe system
(Part 2) : 1965	Head loss in valves and fittings	IS 14536 : 2018	Selection, installation, operation and maintenance of submersible pumpset — Code of practice (<i>first revision</i>)
IS 8034 : 2018	Submersible pumpsets — Specification (<i>third revision</i>)	IS 17018 (Part 1) : 2022	Solar photovoltaic water pumping systems Part 1 Centrifugal pumps — specification (<i>first revision</i>)
IS 9694 (Part 2) : 2023	Selection, installation, operation and maintenance of horizontal centrifugal pumps for agriculture application —		

To access Indian Standards click on the link below:

https://www.services.bis.gov.in/php/BIS_2.0/bisconnect/knowyourstandards/Indian_standards/isdetails/

ANNEX B

(Foreword)

COMMITTEE COMPOSITION

Farm Irrigation and Drainage Systems Sectional Committee, FAD 17

<i>Organization</i>	<i>Representative(s)</i>
In Personal Capacity (<i>D-26, Pusa Campus, Agricultural Research Institute, New Delhi - 110012</i>)	DR T. B. S. RAJPUT (<i>Chairperson</i>)
Automat Industries Private Limited, New Delhi	SHRI DINESH KUMAR SHRI NAWAL KISHORE SHAH (<i>Alternate</i>)
CIPET, Chennai	DR SANDESH KUMAR JAIN SHRI VISHAL VERMA (<i>Alternate</i>)
Dr Y.S. Parmar University of Horticulture and Forestry, Solan	PROF RAJESHWAR SINGH CHANDEL SHRI SUDHIR VERMA (<i>Alternate</i>)
Finolex Plasson Industries Limited, Pune	SHRI VIJAY JADHAV SHRI BAJIRAO BHOSALE (<i>Alternate</i>)
Gujarat Green Revolution Company Limited, Vadodara	DR ASHUTOSH VASANT VADAWALE SHRI R. V. LIMBASHIA (<i>Alternate I</i>) SHRI HARDIK PANCHOLI (<i>Alternate II</i>)
ICAR - Central Institute of Agricultural Engineering, Bhopal	DR RANJAY KUMAR SINGH DR YOGESH A. RAJWADE (<i>Alternate</i>)
ICAR - Central Soil Salinity Research Institute, Karnal	DR DEVENDRA SINGH BUNDELA DR SATYENDRA KUMAR (<i>Alternate</i>)
Indian Council of Agricultural Research, New Delhi	DR KONDAPALLY V. RAMANARAO
Jain Irrigation Systems Limited, Jalgaon	SHRI SUNIL LODHA SHRI ABHIJEET B. JOSHI (<i>Alternate</i>)
Mahatma Phule Krishi Vidyapeeth, Rahuri	DR SACHINKUMAR NANDGUDE DR SHRIMANT RAHOD (<i>Alternate</i>)
Mahindra EPC Irrigation Limited, Nashik	SHRI RAJEEV DESHPANDE SHRI ASHISH KUMAR (<i>Alternate</i>)
National Committee on Precision Agriculture and Horticulture, New Delhi	SHRI ANAND ZAMBRE SHRI ROHIT LALL (<i>Alternate</i>)
Netafim Irrigation Private Limited, Vadodara	SHRI SETHURAMALINGAM S. SHRI MANISH KUMAR PATEL (<i>Alternate</i>)
Nimbus Pipes Limited, Jaipur	SHRI ASHISH KUMAR LATH SHRI HARIDWAR TIWARI (<i>Alternate</i>)
NITI Aayog, New Delhi	DR NEELAM PATEL SHRIMATI ANURADHA BATANA (<i>Alternate</i>)
Premier Irrigation Adritec Limited, Nagpur	SHRI A. K. PRADHAN SHRI G. K. KUMAR (<i>Alternate</i>)
Punjab Agricultural University, Ludhiana	DR J. P. SINGH DR SUNIL GARG (<i>Alternate</i>)
Reliance Industries Limited, Mumbai	SHRI AMIT SHAH
Rivulis Irrigation India Private Limited, Vadodara	SHRI GOPI KETHAVATH

<i>Organization</i>	<i>Representative(s)</i>
Saurashtra Plastics Manufacturer's Association, Rajkot	SHRI ARUN ROKAD SHRI J. K. PATEL (<i>Alternate I</i>) SHRI BHARAT KUMAR V. SIROYA (<i>Alternate II</i>)
School of Agriculture, Indira Gandhi National Open University, New Delhi	DR MUKESH KUMAR
Visvesvaraya Technological University (VTU), Belgavi	DR NAGRAJ S. PATIL
Water Technology Centre, ICAR - Indian Agricultural Research Institute, New Delhi	DR ANIL KUMAR MISHRA DR SUSAMA SUDHISHRI (<i>Alternate</i>)
BIS Directorate General	SHRIMATI SUNEETI TOTEJA, SCIENTIST 'E'/DIRECTOR AND HEAD (FOOD AND AGRICULTURE) [REPRESENTING DIRECTOR GENERAL (<i>Ex-officio</i>)]

Member Secretary
SHRI VIKRANT CHAUHAN
SCIENTIST 'B'/ASSISTANT DIRECTOR
(FOOD AND AGRICULTURE), BIS

Panel to Review Indian Standards on Water Quality and Drainage Systems, FAD 17/P 3

<i>Organization</i>	<i>Representative(s)</i>
Punjab Agricultural University, Ludhiana	DR J. P. SINGH (<i>Convener</i>) DR SUNIL GARG (<i>Alternate</i>)
ICAR - Central Institute of Agricultural Engineering, Bhopal	DR K.V. RAMANA RAO
ICAR - Central Soil Salinity Research Institute, Karnal	DR DEVENDRA SINGH BUNDELA
Haryana Operational Pilot Project, Karnal	DR MOHANLAL GUPTA
Dandekar Brothers LLP, Sangli (<i>Former Director, Rex Poly Extrusion,</i>)	SHRI C. B. DANDEKAR
University of Agricultural Sciences, Dharwad	DR M. S. SHIRAHATTI
In Personal Capacity (<i>Former Project Director, WTC, ICAR-IARI, New Delhi</i>)	DR MAN SINGH
In Personal Capacity (<i>Former Additional Director, WDSC, Jaipur, Govt of Jaipur</i>)	DR C. M. TEJAWAT

Bureau of Indian Standards

BIS is a statutory institution established under the *Bureau of Indian Standards Act, 2016* to promote harmonious development of the activities of standardization, marking and quality certification of goods and attending to connected matters in the country.

Copyright

BIS has the copyright of all its publications. No part of these publications may be reproduced in any form without the prior permission in writing of BIS. This does not preclude the free use, in the course of implementing the standard, of necessary details, such as symbols and sizes, type or grade designations. Enquiries relating to copyright be addressed to the Head (Publication & Sales), BIS.

Review of Indian Standards

Amendments are issued to standards as the need arises on the basis of comments. Standards are also reviewed periodically; a standard along with amendments is reaffirmed when such review indicates that no changes are needed; if the review indicates that changes are needed, it is taken up for revision. Users of Indian Standards should ascertain that they are in possession of the latest amendments or edition by referring to the website-www.bis.gov.in or www.standardsbis.in.

This Indian Standard has been developed from Doc No.: FAD 17 (24389).

Amendments Issued Since Publication

Amend No.	Date of Issue	Text Affected

BUREAU OF INDIAN STANDARDS

Headquarters:

Manak Bhavan, 9 Bahadur Shah Zafar Marg, New Delhi 110002

Telephones: 2323 0131, 2323 3375, 2323 9402

Website: www.bis.gov.in

Regional Offices:

	Telephones
Central : 601/A, Konnectus Tower -1, 6 th Floor, DMRC Building, Bhavbhuti Marg, New Delhi 110002	{ 2323 7617
Eastern : 8 th Floor, Plot No 7/7 & 7/8, CP Block, Sector V, Salt Lake, Kolkata, West Bengal 700091	{ 2367 0012 2320 9474
Northern : Plot No. 4-A, Sector 27-B, Madhya Marg, Chandigarh 160019	{ 265 9930
Southern : C.I.T. Campus, IV Cross Road, Taramani, Chennai 600113	{ 2254 1442 2254 1216
Western : 4 th Floor, NTH Complex (W Sector), F-10, MIDC, Andheri (East), Mumbai 400093	{ 283 25838

Branches : AHMEDABAD, BENGALURU, BHOPAL, BHUBANESHWAR, CHANDIGARH, CHENNAI, COIMBATORE, DEHRADUN, DELHI, FARIDABAD, GHAZIABAD, GUWAHATI, HARYANA (CHANDIGARH), HUBLI, HYDERABAD, JAIPUR, JAMMU, JAMSHEDPUR, KOCHI, KOLKATA, LUCKNOW, MADURAI, MUMBAI, NAGPUR, NOIDA, PARWANOO, PATNA, PUNE, RAIPUR, RAJKOT, SURAT, VIJAYAWADA.