

भारतीय मानक  
Indian Standard

IS 18972 (Part 100) : 2024  
IEC TS 62600-100 : 2012

समुद्री ऊर्जा — तरंग, ज्वार और अन्य जल  
धारा परिवर्तक  
भाग 100 विद्युत उत्पादक तरंग ऊर्जा परिवर्तक —  
विद्युत प्रदर्शन आकलन

**Marine Energy — Wave, Tidal and  
Other Water Current Converters  
Part 100 Electricity Producing Wave  
Energy Converters — Power  
Performance Assessment**

ICS 27.140

© BIS 2024

© IEC 2012



भारतीय मानक ब्यूरो  
BUREAU OF INDIAN STANDARDS  
मानक भवन, 9 बहादुर शाह ज़फर मार्ग, नई दिल्ली-110002  
MANAK BHAVAN, 9 BAHADUR SHAH ZAFAR MARG  
NEW DELHI - 110002  
[www.bis.gov.in](http://www.bis.gov.in)  
[www.standardsbis.in](http://www.standardsbis.in)

October 2024

Price Group 12

## NATIONAL FOREWORD

This Standard (Part 100) which is identical to IEC 62600-100 : 2012 'Marine energy —Wave tidal and other water current converters — Part 100 : Electricity producing wave energy converters — Power performance assessment' issued by the International Electrotechnical Commission (IEC) was adopted by the Bureau of Indian Standards on the recommendation of the Marine Energy Conversion Systems Sectional Committee and approval of the Electrotechnical Division Council.

The text of the IEC standard has been approved as suitable for publication as an Indian Standard without deviations. Certain conventions are, however, not identical to those used in Indian Standards. Attention is particularly drawn to the following:

- a) Wherever the words 'International Standard' appears referring to this standard, they should be read as 'Indian Standard'; and
- b) Comma (,) has been used as a decimal marker, while in Indian Standards the current practice is to use a point (.) as the decimal marker.

In this adopted standard, reference appears to International Standards for which Indian Standards also exists. The corresponding Indian Standards, which are to be substituted, are listed below along with their degree of equivalence for the editions indicated:

<i>International Standard</i>	<i>Corresponding Indian Standard</i>	<i>Degree of Equivalence</i>
ISO 8601 Data elements and interchange formats — Information interchange — Representation of dates and times	IS/ISO 8601-1 : 2019 Date and time representations for information interchange: Part 1 Basic rules	Identical
NDBC : 2009 Technical document 09-02 Handbook of automated data quality control checks and procedures. National Data Buoy Center, August 2009	IS/IEC 2009 : 1975 Method for calibration of horizontal and tilted oil storage tanks ( <i>first revision</i> )	Identical

The Committee has reviewed the provisions of the following International Standards referred in this adopted standard and decided that they are acceptable for use in conjunction with this standard.

<i>International Standard</i>	<i>Title</i>
IEC 60044-1	Instrument transformers — Part 1: Current transformers
IEC 60688	Electrical measuring transducers for converting a.c. electrical quantities to analogue or digital signals
IEC 61000-3 (all parts)	Electromagnetic compatibility (EMC) — Part 3: Limits
IEC 61869-3	Instrument transformers — Part 3: Additional requirements for inductive voltage transformers
ISO/IEC Guide 98-1 : 2009	Uncertainty of measurement — Part 1: Introduction to the expression of uncertainty in measurement
ISO/IEC Guide 98-3 : 2008	Uncertainty of measurement — Part 3: Guide to the expression of uncertainty in measurement (GUM : 1995)

For the purpose of deciding whether a particular requirement of this standard is complied with, the final value, observed or calculated expressing the result of a test, shall be rounded off in accordance with IS 2 : 2022 'Rules for rounding off numerical values (*second revision*)'. The number of significant places retained in the rounded off value should be the same as that of the specified value in this standard.

## CONTENTS

INTRODUCTION.....	v
1 Scope.....	1
2 Normative references .....	1
3 Symbols and units .....	2
4 Sequence of work.....	4
5 Test site characterization .....	4
5.1 General.....	4
5.2 Measurements.....	4
5.2.1 Wave measurement for wave power .....	4
5.2.2 Current measurement.....	5
5.2.3 Tidal measurement.....	5
5.2.4 Bathymetric survey.....	5
5.2.5 Calculation of wave spatial transfer model.....	5
5.2.6 Modelling of the test site.....	5
6 Methodology.....	6
6.1 General.....	6
6.2 Sample duration and frequency.....	6
6.3 Simultaneity .....	7
6.4 Data recording.....	7
6.4.1 Amount of data to be recorded .....	7
6.4.2 Data format and retaining .....	7
7 Measurement and data collection for wave data .....	7
7.1 General.....	7
7.2 WMI and calibration.....	7
7.3 Instrumentation location .....	7
7.3.1 General .....	7
7.3.2 Direct measurement .....	7
7.3.3 Measures with spatial transfer model.....	8
7.3.4 Correction for WEC interference .....	8
7.4 Metocean data .....	8
7.5 Procedure for the calculation of derived parameters.....	8
8 WEC power output measurements.....	9
8.1 WEC output terminals.....	9
8.2 Power measurement point.....	9
8.3 Power measurements.....	10
8.3.1 General .....	10
8.3.2 Limitations on power production .....	10
8.4 Instruments and calibration .....	10
9 Determination of power performance .....	11
9.1 General.....	11
9.2 Structure of the normalized power matrix .....	11
9.2.1 Core structure .....	11
9.2.2 Sub-division of the normalized power matrix.....	11
9.2.3 Calculation of the capture length .....	11

9.2.4	Representation of the capture length matrix.....	11
9.3	Calculation of power matrix .....	12
10	Calculation of mean annual energy production (MAEP) .....	12
10.1	General .....	12
10.2	Standard methodology.....	12
10.3	Alternative methodology .....	13
10.4	Completeness of the capture length matrix for MAEP .....	13
Annex A (informative)	Example production of a normalized power matrix.....	14
Annex B (normative)	Method for power loss compensation where the measurement point is located on shore.....	22
Annex C (normative)	Evaluation of uncertainty.....	25
Annex D (normative)	Error analysis of the wave spatial transfer model .....	27
Bibliography.....		29
Figure 1 – Timeline of assessment.....		4
Figure 2 – Data flow diagram .....		6
Figure A.1 – Power scatter.....		15
Figure B.1 – Location options for metering equipment.....		22
Figure B.2 – Positive sequence cable model .....		23
Table 1 – Symbols and units .....		2
Table A.1 – Sample data.....		14
Table A.2 – Average capture length .....		16
Table A.3 – Standard deviation of capture length .....		17
Table A.4 – Maximum capture length .....		18
Table A.5 – Minimum capture length .....		19
Table A.6 – Number of data samples .....		20
Table A.7 – Power matrix.....		21
Table C.1 – List of uncertainty components .....		25

## INTRODUCTION

This part of IEC 62600, which is a Technical Specification, provides performance assessment methods for Wave Energy Conversion Systems (WECS). A Wave Energy Converter (WEC) is a device which generates electricity using the action of water waves and delivers electricity to an electrical load.

Wave energy industry development is transitioning from preliminary stages to commercial production stages. Validated data gathering and processing techniques are important to improve existing technologies. This technical specification will be subject to changes as data are collected and processed from testing of WECS.

The expected users of the specification include:

- device developers who want to validate the performance of their WEC;
- investors who want to assess the performance of a device developer's WEC;
- project developers who want to assess the performance of their project against manufacturer's claims;
- surveyors contracted to carry out the assessment.



*Indian Standard***MARINE ENERGY — WAVE, TIDAL AND OTHER WATER  
CURRENT CONVERTERS****PART 100 ELECTRICITY PRODUCING WAVE ENERGY CONVERTERS —  
POWER PERFORMANCE ASSESSMENT****1 Scope**

This part of IEC 62600, which is a Technical Specification, provides a method for assessing the electrical power production performance of a Wave Energy Converter (WEC), based on the performance at a testing site.

The scope of this Technical Specification includes:

- a) all WECs that produce electrical power from wave energy;
- b) all sea resource zones (near and offshore, deep and shallow water);
- c) the specification applies to commercial scale WECs that are:
  - 1) compliantly moored,
  - 2) tautly moored,
  - 3) bottom mounted,
  - 4) shore mounted.

The scope of this Technical Specification does not include:

- a) WECs that produce other forms of energy unless this energy is converted into electrical energy;
- b) resource assessment;
- c) scaled devices in test facilities (tank or scaled sea conditions) where any scaling would need to be carried out to extrapolate results for a full scale device;
- d) power quality issues;
- e) environmental issues;
- f) power matrix transposition from one location to another.

This Technical Specification provides a systematic method which includes:

- measurement of WEC power output in a range of sea states;
- WEC power matrix development;
- an agreed framework for reporting the results of power and wave measurements.

**2 Normative references**

The following documents, in whole or in part, are normatively referenced in this document and are indispensable for its application. For dated references, only the edition cited applies. For undated references, the latest edition of the referenced document (including any amendments) applies.

IEC 60044-1, *Instrument transformers – Part 1: Current transformers*

**IS 18972 (Part 100) : 2024**  
**IEC TS 62600-100 : 2012**

IEC 60688, *Electrical measuring transducers for converting a.c. electrical quantities to analogue or digital signals*

IEC 61000-3 (all parts), *Electromagnetic compatibility (EMC) – Part 3: Limits*

IEC 61869-3, *Instrument transformers – Part 3: Additional requirements for inductive voltage transformers*

ISO/IEC Guide 98-1:2009, *Uncertainty of measurement – Part 1: Introduction to the expression of uncertainty in measurement*

ISO/IEC Guide 98-3:2008, *Uncertainty of measurement – Part 3: Guide to the expression of uncertainty in measurement (GUM:1995)*

ISO 8601, *Data elements and interchange formats – Information interchange – Representation of dates and times*

*EquiMar: Protocols for the equitable assessment of marine energy converters, Part II*, Chapters I.A.1 through I.A.5., Editors: David Ingram, George Smith, Claudio Bittencourt Ferreira, Helen Smith. European Commission 7th framework programme grant agreement number 213380, First Edition 2011

NDBC:2009, Technical Document 09-02, *Handbook of automated data quality control checks and procedures*. National Data Buoy Center, August 2009

### 3 Symbols and units

For the purposes of this document, the symbols and units listed in Table 1 apply.

**Table 1 – Symbols and units**

Symbol	Definition	Units
$f_{cell_i}$	Frequency of occurrence in the $i^{th}$ bin	Hz
$C_{cable}$	Total positive sequence line-to-line capacitance of subsea cable	farad
$c_g$	Group velocity	m/s
$f$	Frequency	Hz
$f_i$	Frequency at component $i$	Hz
$G(\theta, f)$	Energy at $f$ distributed with angle $\theta$ NOTE $\int_{-\pi}^{+\pi} G(\theta, f) \cdot d\theta = 1$	1/rad
$h$	Water depth	m
$H_{m0}$	Spectral estimate of significant wave	m
$H_s$	Significant wave height	m
$I_{meas}$	Line current	A
$J$	Omnidirectional measured wave energy flux	W/m
$J_i$	Omnidirectional measured wave energy flux per bin	W/m
$L$	Capture length	m
$L_i$	Capture length per bin	m



Symbol	Definition	Units
$M$	Number of data sets in a bin	-
MAEP	Mean Annual Energy Production	Wh
$m_n$	Frequency $n^{\text{th}}$ order moments of the variance spectrum	-
$n$	Number of sea states	-
$N$	Number of bins	-
$P$	Measured power output	W
$P_i$	Measured power output per bin	W
$P_{\text{meas}}$	Real power	W
$PF_{\text{meas}}$	Power factor	-
$Q_{\text{meas}}$	Reactive power	W
$R_{\text{cable}}$	Total positive sequence resistance of subsea cable	$\Omega$
$S$	Spectral density	$\frac{\text{m}^2}{\text{Hz}}$
$S(f)$	Spectral density as function of frequency	$\frac{\text{m}^2}{\text{Hz}}$
$S(f)_{\text{WEC}}$	Spectral density at WEC Equals $T(f, t, \theta, h, \dots) \cdot S(f)_{\text{WMI}}$	$\frac{\text{m}^2}{\text{Hz}}$
$S(f)_{\text{WMI}}$	Spectral density at WMI	$\frac{\text{m}^2}{\text{Hz}}$
$S(f, \theta)$	Directional spectrum $S(f) \cdot G(\theta, f)$	$\frac{\text{m}^2}{\text{Hz} \cdot \text{rad}}$
$S_i$	Spectral density at frequency component $i$	$\frac{\text{m}^2}{\text{Hz}}$
$S_p$	Standard deviation	-
$t$	Time lag or shift between the WMI and the WEC	s
$T$	Operational hours per record	h
$T_e$	Energy period	s
$T(f, t, \theta, h, \dots)$	Spatial transfer model, for correction of the spectral density measured at the WMI to the WEC NOTE Not all the variables are listed. The correction depends on the test site.	-
$U$	Line-to-line voltage	V
$U_{\text{meas}}$	Line-to-line r.m.s. voltage	V
$V_{p1+}, V_{p1-}$	WEC side positive sequence voltage	V
$V_{p2+}, V_{p2-}$	Shore side positive voltage	V
$X_{\text{cable}}$	Total positive sequence reactance of subsea cable	$\Omega$
$\Delta f_i$	Frequency spacing	Hz
$\rho$	Fluid density	$\frac{\text{g}}{\text{m}^3}$
$\theta$	Wave direction	$^\circ$
$\varphi$	Phase angle	$^\circ$

#### **4 Sequence of work**

Figure 1 shows the sequenced of work for the assessment as described in this technical specification. The pre-test sections shall be conducted prior to the testing period. Following the testing period the post-test sections shall be conducted.

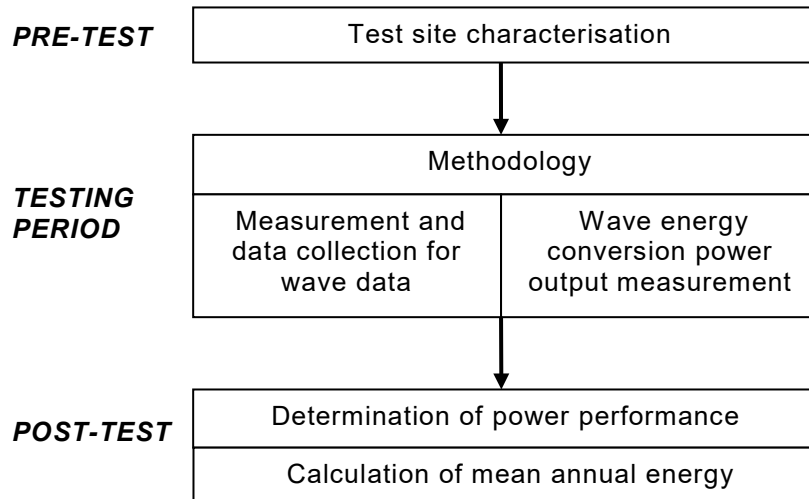

**Figure 1 – Timeline of assessment**

#### **5 Test site characterization**

##### **5.1 General**

An analysis of the prospective test site shall be undertaken to ensure that it is suitable for power assessment of a WEC. The incident wave climate shall be evaluated to ensure the power performance matrix can be populated. In order to infer the incident wave power at the location of a WEC, the effect of bathymetry and marine currents on the incident wave climate shall be sufficiently analyzed to determine whether a transfer model between the Wave Measurement Instrument (WMI) and WEC will be required. If a transfer model is required, the analysis shall support the development of a suitable transfer model.

##### **5.2 Measurements**

###### **5.2.1 Wave measurement for wave power**

A WMI shall be deployed at the proposed WEC location prior to WEC deployment. A second WMI shall be deployed simultaneously at the proposed post-deployment wave measurement location. The WMIs shall be deployed for a minimum of 3 months prior to WEC deployment and it is recommended the WMIs record data for 12 months prior to WEC deployment to account for seasonal variations.

The spectral data shall be calculated from WMI time series data. Estimates of the significant wave height estimate and energy period shall be calculated from the spectral data. The following parameters, to be used to determine the power matrix, shall be included in the determination of the power matrix:

- a) spectral shape;
- b) directionality of waves;
- c) directional frequency spectrum;
- d) water depth including tidal effect;

- e) tidal and marine current, direction and velocity;
- f) wind speed and direction;
- g) density of water;
- h) occurrence and thickness of ice.

Parameters from the above list that have not been recorded, and thus not included in the development the power matrix, shall be identified and the rationale for their exclusion justified.

### **5.2.2 Current measurement**

Marine currents at the test site shall be recorded and documented. The current speed and direction data shall be measured simultaneously with the wave measurement and shall extend over a minimum of 30 days. The sampling period shall be a maximum of 10 minutes. At least one current speed and direction record will be taken from the upper half of the water column during the deployment period. The primary purpose of current records is to facilitate the development of a marine current model of the area. Tidal and non-tidal currents shall be estimated and differentiated.

It is recommended, however, to measure current velocity and directions at different points of the water column in order to adequately describe the velocity profile at the site.

### **5.2.3 Tidal measurement**

Tidal heights shall be recorded at the test site. The measurements shall extend over at least 30 days and shall be analysed to estimate tidal ranges.

### **5.2.4 Bathymetric survey**

The boundary of the test site shall be defined and documented. A bathymetric survey of the area shall be undertaken and documented. The resolution of the bathymetric survey shall be as needed to support the wave spatial transfer model, see 5.2.5.

The survey should provide the details on the bottom profile.

### **5.2.5 Calculation of wave spatial transfer model**

The sea state at the location of the WMI shall be representative of the sea state at the location of the WEC. If the difference between the energy flux at the WMI and the WEC – as determined by the deployment of a minimum of two WMIs, one at the wave measurement location and one at the WEC location – is less than 10,0 % for 90,0 % of the records then it can be assumed that the wave field is statistically equivalent.

NOTE It is expected that this will be the case for a well-chosen deep-water test site.

If the above condition is not met then a spatial transfer model shall be generated and validated. The spatial transfer model can either be an existing modelling program or a custom modelling program. The modelling program shall be validated. The accuracy of the model shall be determined as shown in Annex D.

### **5.2.6 Modelling of the test site**

The spatial transfer model shall predict the spectrum at the WEC based on the spectrum at the WMI. The test site should be modelled to assist in the development of a spatial transfer model. The spatial transfer model shall be acceptable if it predicts the energy flux at the WEC to within 10,0 % of the measured energy flux for 90,0 % of the of the data recorded according to 5.2.1.

NOTE The spatial transfer model would generally be in the form:

$$S(f, \theta)_{WEC} = T(f, t, \theta, h, \dots) \cdot S(f, \theta)_{WMI} \quad (1)$$

## 6 Methodology

### 6.1 General

This technical specification governs the methodology for measurement, analysis and presentation of data to assess the power performance of an electricity generating WEC.

The sea state incident at the WEC shall be measured to the accuracy specified in Clause 7. The sea state measurements shall be analysed to give the parameters for each sample sufficient to describe the sea state as specified in Clause 7.

The electrical power production at the WEC shall be measured to the accuracy specified in Clause 8. The electrical power production measurements shall be analysed to give the parameters for each sample sufficient to describe the electrical power production as specified in Clause 8.

A power matrix shall be compiled as specified in Clause 9 which compares the parameters of the sea state samples and the electrical power production samples (see Figure 2).

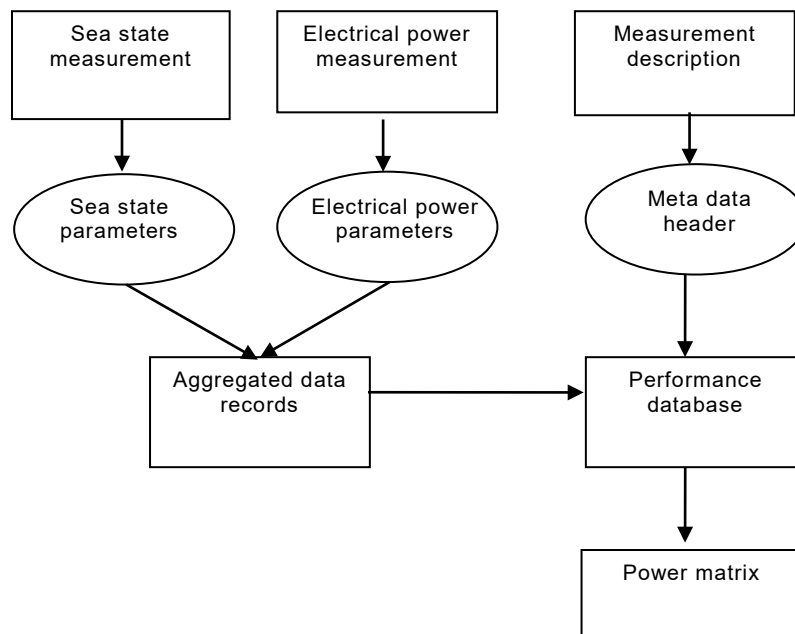

Figure 2 – Data flow diagram

### 6.2 Sample duration and frequency

The parameters describing the sea state and electrical power production for each sample shall be recorded as specified in this Clause 6. The minimum sample duration shall be 20 min. It shall be reported at least every hour.

The minimum sample frequency shall be 1,0 Hz.

NOTE Sample duration will affect the accuracy of the measurement. A short sampling duration can result in the poor characterization of the sea state.

### **6.3 Simultaneity**

The measurements from a WMI and WEC power output shall be measured at the same time to provide correlation between sea state and WEC output power. WMI and WEC data shall be synchronized so that the sea-state incident at the WEC can be correlated with WMI records. It is recommended that WMI data be recorded simultaneously with WEC power data for a minimum of one half of the sample duration.

NOTE The spatial transfer model shall be used to correct any time delay between the measurements taken at the WMI and the location of the WEC. The correction for the time delay will not affect the simultaneity of the measurements.

### **6.4 Data recording**

#### **6.4.1 Amount of data to be recorded**

The minimum amount of data recorded shall be based on the design operating envelope of interest. This shall define the amount of testing that is required to develop a power matrix.

The minimum testing duration shall be six months and be representative of the deployment location.

NOTE Spectral shape can vary with seasons leading to variations in the power matrix.

#### **6.4.2 Data format and retaining**

The data shall provide a record of sea state and electrical power production over time. Each aggregated data record shall be date and time stamped using ISO 8601. The records shall be annotated with quality control flags giving the results of the quality control checks carried out during the recording and analysis path. The records shall be recoverable in ASCII format with a descriptive header for each data record.

## **7 Measurement and data collection for wave data**

### **7.1 General**

The purpose of this Clause 7 is to specify the wave and environmental data required to produce a power matrix for a WEC. This Clause 7 shall also provide the methodology for analyzing the wave data in order to characterise the environmental conditions. The minimum sample frequency shall be 1,0 Hz.

### **7.2 WMI and calibration**

The calibration, accuracy, and limitation of the WMI shall be documented to reference NDBC:2009 Technical Document 09-02.

### **7.3 Instrumentation location**

#### **7.3.1 General**

WMI deployment location or locations shall be selected to best represent the sea state at the WEC. The WMI location will be selected to minimize its effect on the WEC and the WEC on the WMI. The effects of reflection, radiation, diffraction, and shadowing shall be considered when selecting the WMI location effects.

#### **7.3.2 Direct measurement**

Direct measurement can be used if the site investigations as specified in Clause 5 have not revealed any significant variations in the sea states between the WEC and WMI. The WMI data will be representative of the sea state at the WEC. The WMI and WEC data can be processed and analysed directly.

### 7.3.3 Measures with spatial transfer model

A spatial transfer model shall be used to account for the changes occurring between the position of the WMI and the WEC. The spatial transfer function will provide the sea state data to be analysed with the WEC data.

### 7.3.4 Correction for WEC interference

The WMI shall be positioned to reduce the amount of interference from the WEC. A model shall be developed to estimate the waves from radiation and refraction. The WMI shall be placed in a location where the average radiated wave energy has decayed by at least 90 %.

## 7.4 Metocean data

It is recommended to measure and record all relevant parameters believed to have an influence on power production. Since there are several factors that may affect the performance of a WEC, depending on its type, awareness of any correlation between power and a specific parameter should be sought and reported. A listing of the parameters is included in 5.2.1. As a minimum requirement, the significant wave height estimate  $H_{m0}$ , the wave energy period  $T_e$ , and the wave energy flux  $J$  shall be calculated using the measured wave data and reported.

Other parameters that have a significant effect on the power production of the WEC shall also be recorded and calculated. The calculation of any additional parameters shall be defined and reported in sufficient detail to allow for repeatability (see Annex C). The accuracy of the calculated parameters shall be given, according to the uncertainty estimation defined by ISO/IEC Guide 98-1 and ISO/IEC Guide 98-3.

Directly measured parameters will be expressed with indication of absolute error. Specifications on the type, location, calibration, and accuracy of the measurement instrument shall be given.

## 7.5 Procedure for the calculation of derived parameters

Wave data shall be described by wave spectra which provides information on how the wave elevation variance is distributed with frequency.

- a) Frequency  $f_i$ : A range of frequencies will be selected for spectral analysis depending on the measurement instrument and sampling rate. The spectral frequency range used for calculation should be between 0,033 Hz and 0,50 Hz with the number of frequency bins determined from data analysis. Frequency bin width should not exceed 0,015 Hz.
- b) The frequencies shall be defined using either a geometric progression where the ratio between two adjacent frequencies is constant, or a fixed frequency spacing. In either case the maximum frequency bin width shall not exceed 0,015 Hz.

NOTE 1 Currents may have a significant effect on wave and power parameters due to Doppler shift. Refer to ISO 19901-1:2005 for the correction procedure. If the ratio of intrinsic to apparent wave frequency is between 0,9 and 1,1, corrections are not required. Any corrections from apparent to intrinsic wave shall be clearly noted.

- c) Frequency moments of the variance spectrum  $m_n$ . The moments of the spectrum from  $n = -1$  and  $n = 0$  shall be calculated from

$$m_n = \sum_{i=1}^N S_i f_i^n \Delta f_i \quad (2)$$

- d) The spectral significant wave height estimate  $H_{m0}$  is defined as:

$$H_{m0} = 4,00 \sqrt{m_0} \quad (3)$$

e) The energy period  $T_e$  is defined as:

$$T_e = \frac{m-1}{m_0} \quad (4)$$

f) The wave energy flux  $J$  (omnidirectional) is defined as:

$$J = \rho g \sum_i S_i c_{gi} \Delta f_i \quad (5)$$

where

$g$  is the gravitation constant equal to 9,8 m/s<sup>2</sup>.

g) The group velocity is defined as:

$$c_{gi} = \frac{1}{2} \cdot c_{pi} \cdot \left[ 1 + \frac{2 \cdot k_i \cdot h}{\sinh(2 \cdot k_i \cdot h)} \right] \quad (6)$$

$$c_{pi} = \sqrt{\frac{g}{k_i} \cdot \tanh(k_i \cdot h)} \quad (7)$$

NOTE 2 In deep water conditions this simplifies to:

$$J = \frac{\rho g^2}{64\pi} H_{m0}^2 T_e \quad (8)$$

NOTE 3 The directionality of the sea state is important when the WEC is directionally sensitive. The Metocean data will be recorded as a parameter. The directionality of the waves can be described as a mean direction and a parameter representing the spreading.

## 8 WEC power output measurements

### 8.1 WEC output terminals

In the case of an AC grid-connected WEC its output terminals shall be at the point where the output power is in the form of AC at the network frequency.

In the case of a non-grid connected WEC, its output terminals shall be at the point where the power is connected directly to the load. The output power shall be in the form of AC at a commonly used network frequency (e.g. 50 Hz, 60 Hz), and at a commonly used grid connection voltage level (e.g. 400 V, 6,6 kV). These details shall be clearly stated.

The output terminal point shall be clearly stated.

### 8.2 Power measurement point

The power measurement point should be at the electrical output terminals of the WEC.

When this is not possible the power measurement point shall be at a point where other effects (such as losses due to cables or other electrical components) between the measurement point and the output terminals may be determined. In this case the methodology for these corrections shall be fully detailed. Power loss correction is only permitted for transmission equipment that is required for measuring the electrical power at the WEC output terminal. The power measurement point shall be clearly stated. In the case where the power measurement point differs from the output terminals the justification shall be made.

NOTE Annex B contains a method for cable loss compensation where the measurement point is located on shore.

### **8.3 Power measurements**

#### **8.3.1 General**

The net electric power of the WEC shall be measured, inclusive of any reduction due to system energising power and necessary ancillary loads on board the WEC. The power shall be recorded at minimum of 2 Hz, the power signal having been subjected to a suitable anti-aliasing filter.

The mean, standard deviation, maximum and minimum of the digitized values which occur in each sample shall be recorded.

#### **8.3.2 Limitations on power production**

In the case of an AC grid connected WEC, an assessment shall be made of any potential limitations imposed on WEC power export capacity due to the grid connection. These may include the capacity of the connection itself or the requirement for significant reactive power export, resulting in constraints on the WEC power output under certain conditions. In the case where such constraints can occur, a method to identify when the WEC is operating under constrained output power conditions shall be put in place. Output power data during these conditions shall be identified and may be excluded for use in the power performance matrix.

It is recommended in this circumstance that an external dump load be installed in order to eliminate the WEC power output constraint.

### **8.4 Instruments and calibration**

The net electric power of the WEC shall be measured using a power measurement device such as a transducer and be based upon measurements of current and voltage on a minimum of two phases.

Electrical transducers and the power measurement device used in the electrical measurements should be class 0,5 or better, should be calibrated to traceable standards and shall meet the requirements of the following standards:

- power transducers : IEC 60688;
- current transformers: IEC 60044-1;
- voltage transformers: IEC 61869-3.

The operating range of the power measurement device shall be sufficient to include all positive peaks corresponding to net generation and all negative peaks corresponding to net imported power. As a guide, the full-scale working range of the power measurement device and transducers should be at least:

- export: 1 % to 200 % of rated power;
- import: –1 % to –50 % of rated power.

At the low power range of  $\pm 1$  % of the device's rated capacity, where the working range of the power measurement device does not allow for class 0,5 measurements, the power recorded should be zero. At the low power range where the working range of the transducer does allow for class 0,5 measurements, their measured values shall be recorded.

NOTE It is important that current transformers are specified correctly as they become non-linear for low currents ( $\leq 5$  % of their range or thereabouts).



## **9 Determination of power performance**

### **9.1 General**

The power performance of the WEC shall be presented using a normalized power matrix. The normalization shall be calculated using the capture length and the average bin power. The power performance of a WEC can be determined for two distinct purposes. The first purpose is to define the power performance of a WEC so that it can subsequently be used to predict energy yield at a different site. In this case the capture length matrix should be produced as detailed in 9.2.

NOTE The capture length matrix is preferred over the power matrix because it is less sensitive to sea-state parameters and thus less affected by the method of bins. However, the calculation of the power matrix is specified in 9.3 to enable its calculation where appropriate.

The second purpose is to assess the power performance of a WEC to determine if it meets the specified power performance claims. If a capture length matrix for the WEC exists then this can be achieved by comparing the measured power performance to the capture length matrix.

### **9.2 Structure of the normalized power matrix**

#### **9.2.1 Core structure**

The normalized power matrix shall be constructed by applying the “method of bins” to the capture lengths (see 9.3). The bins shall be defined by at least the significant wave height estimate,  $H_{m0}$  and energy period,  $T_e$ . The bins for significant wave height shall have a maximum width of 0,5 m and the bins for the energy period shall have a maximum width of 1,0 s.

#### **9.2.2 Sub-division of the normalized power matrix**

Additional indices, such as the mean wave direction or spectral bandwidth, may be added to the normalized power matrix to reduce the variability of capture length in each bin.

NOTE It is advantageous to sub-divide the normalized power matrix if by doing so it reduces the variability of the performance prediction, thereby giving greater confidence in the estimation of WEC energy production.

#### **9.2.3 Calculation of the capture length**

The capture length is equal to the net electrical power capture divided by the wave energy flux.

$$L = \frac{P}{J} \quad (9)$$

#### **9.2.4 Representation of the capture length matrix**

In cases where only significant wave height,  $H_{m0}$  and energy period,  $T_e$  are used to define the capture length matrix a table can be used to fully represent the capture length matrix. Where more indices are used to define the capture length matrix the significant wave height and energy period should continue to be used together to organise the data sets to facilitate usage with wave climate scatter diagrams.

Each bin of the capture length matrix shall contain at least the following information:

- a) the average capture length of all the data sets in the bin;
- b) the standard deviation of the capture length of all the data sets in the bin;
- c) the maximum capture length of all the data sets in the bin;
- d) the minimum capture length of all the data sets in the bin;

e) the number of data sets in the bin.

The average and standard deviation of the capture length for each bin is calculated according to the equations:

$$\bar{L} = \frac{1}{M} \times \sum_{i=1}^M L_i \quad (10)$$

$$s_p = \sqrt{\frac{1}{M-1} \times \sum_{i=1}^M (L_i - \bar{L})^2} \quad (11)$$

### 9.3 Calculation of power matrix

The power matrix shall be calculated by multiplying the average and standard deviation of the capture length for each bin (as defined in 9.2.4) by the wave energy flux at the centre of the bin. The wave energy flux density at the centre of the bin shall be calculated using a representative spectral shape and the spectral shape used for each bin recorded and a justification provided. The spectral shape used can be different for each bin.

## 10 Calculation of mean annual energy production (MAEP)

### 10.1 General

The mean annual energy production of a WEC at the specific site shall be calculated by applying the wave energy resource data defined by *EquiMar: Protocols for the Equitable Assessment of Marine Energy Converters, Part II*, chapters I.A.1 through I.A.5 to the power performance of the particular WEC. The MAEP shall be calculated assuming an availability of 100 %.

NOTE The *EquiMar* resource assessment supports devices principally located in deep water away from the shoreline.

### 10.2 Standard methodology

Where a time series of the wave energy resource is available the MAEP shall be calculated in accordance with mathematical Formula (12). A minimum of 10 years of wave energy resource data should be used for the calculation of the mean annual energy production. If the mean annual energy production is calculated with less than 10 years of wave energy resource data this shall be noted explicitly. The wave energy resource data set shall be unbiased, containing the number of sea-states for each month proportional to the number of days in the month.

$$\text{MAEP} = \frac{T}{n} \cdot \sum_{i=1}^{i=n} L_i \cdot J_i \quad (12)$$

where

$T$  is the average length of a year which is 8 766 h.

The power production shall be calculated for each individual sea-state using linear interpolation of the capture length matrix. If not available, the capture length matrix can be regenerated by dividing the bin values in the power matrix by the wave energy flux density at the centre of each bin using the recorded spectral shape represented shape as determined in 9.3.

NOTE It is in a WEC developer's interest to ensure that the power matrix is appropriate for all possible sea-states. In particular, power production at high significant wave heights can affect whether the WEC will be in survival mode where power production is zero, or whether it can continue to produce power.

### **10.3 Alternative methodology**

If the wave energy resource data is only available as a scatter diagram then the mean annual energy production shall be calculated using the power production at the centre of each bin in the scatter diagram in accordance with Equation (13) subject to the condition in Equation (14). The power production of the bin shall be calculated as specified in 10.2. The contribution of each bin in the scatter diagram to the mean annual energy production shall be weighted based on the frequency of occurrence of the particular bin as defined in the scatter diagram. If the wave resource scatter diagram has different bin sizes to the capture length matrix, then two-dimensional linear interpolation of the capture length matrix can be performed to align the bins of the two matrices.

$$\text{MAEP}_{(\text{ALT})} = T \cdot \sum_{i=1}^{i=N} L_i \cdot J_i \cdot f_i \quad (13)$$

$$\sum_{i=1}^{i=N} f_i = 1,0 \quad (14)$$

### **10.4 Completeness of the capture length matrix for MAEP**

The MAEP shall be calculated in two ways, one designated "MAEP-measured", and the other "MAEP-interpolated". MAEP-measured is calculated assuming zero capture length in all empty bins of the capture length matrix. MAEP-interpolated is calculated assuming the capture length of empty bins is equal to the average of adjacent filled bins.

Both MAEP-measured and MAEP-interpolated shall be reported, The MAEP-measured shall be labelled as "incomplete" when calculations show that the MAEP-measured differs from the MAEP-interpolate by more than 5 %. In these circumstances the capture length matrix should be considered as inadequate for calculation of the MAEP and the requirement for more extensive testing highlighted.

## Annex A (informative)

### Example production of a normalized power matrix

#### A.1 General

The following Clause A.2 and Figure A.1 describe the method on how to display empirical WEC data performance data in a standard format. The data has been generated from simulations of a heave only point absorber WEC, and is designed to match closely with what would be expected from measured sea test data. The data has been grouped using bins, with the tables below indicating the bin centres.

#### A.2 Sample data

The following Table A.1 represents an extract of the wave data as measured by WMI, and WEC performance data gathered. Wave characteristics from the measurement equipment have been used to calculate the wave power for the given  $H_{m0}$  and  $T_e$ . Power is measured at the output terminals of the WEC as defined in this technical specification.

**Table A.1 – Sample data**

$H_{m0}$ m	$T_e$ s	$P$ kW	$J$ kW/m	$L$ m
4,86	6,85	443,70	79,38	5,59
1,16	6,97	27,27	4,60	5,93
1,05	7,18	25,21	3,88	6,49
1,72	7,30	72,13	10,60	6,81
1,39	7,41	49,82	7,02	7,09
1,96	7,62	109,43	14,36	7,62
3,83	7,84	458,68	56,42	8,13
1,61	8,05	87,44	10,24	8,54
3,37	8,17	397,34	45,52	8,73
1,27	8,38	59,36	6,63	8,95
2,31	8,59	203,12	22,49	9,03
2,08	8,71	166,74	18,49	9,02
1,50	8,82	89,26	9,74	9,17
-	-	-	-	-

The full range of data measured as it occurred during the measurement period is shown in Figure A.1. This represents a total of 6 180 measured data points over a period of time. This plot shows the variation in electrical power output over a range of  $H_{m0}$  and  $T_e$ .

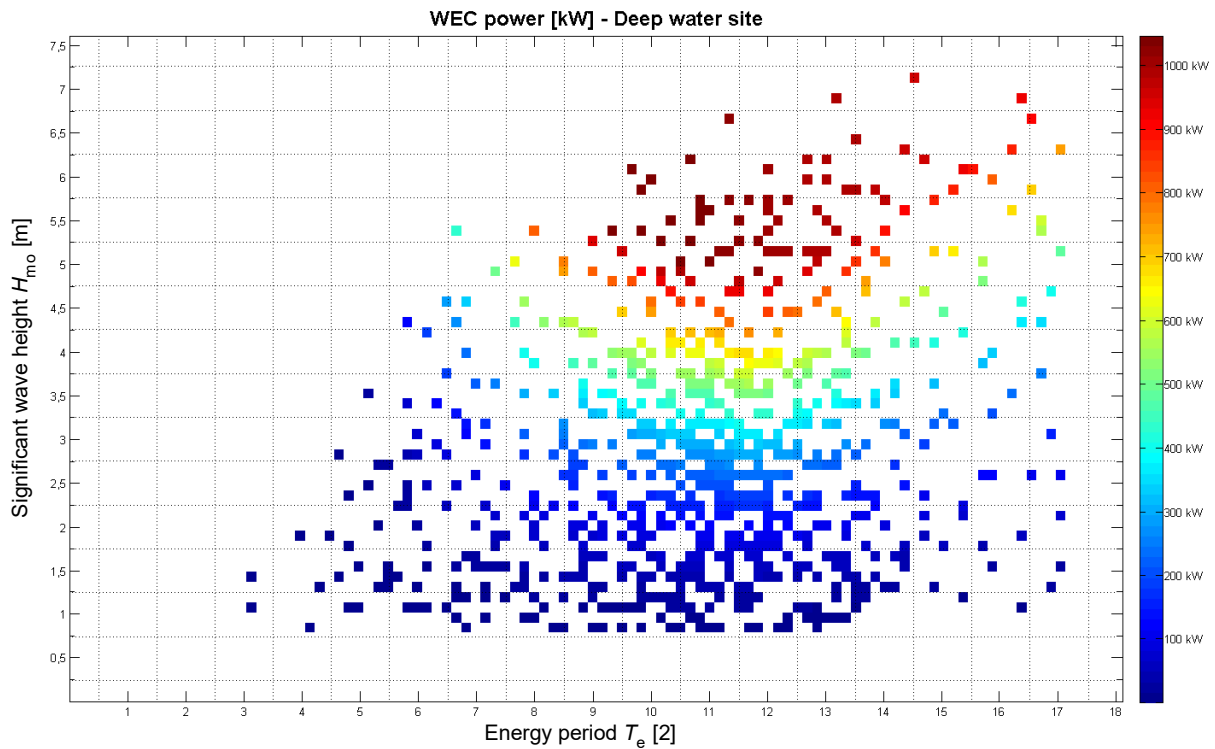

**Figure A.1 – Power scatter**

This large data set needs to be reduced to the standard discretisation. The bin sizes chosen are 0,5 m for  $H_{m0}$  and 1 s for  $T_e$  as defined by 9.2. The tables which follow display the value of the bin centre e.g. all data within the interval of 8,5 s to 9,5 s is displayed in the 9 s bin. The same method is used for the  $H_{m0}$  values.

The capture length for each of the data samples is calculated on the basis of the measured power and the wave energy flux, separated into the different bins and averaged over each bin. Table A.2 below shows the average capture length for each bin. Empty bins indicate no measurements were recorded for that combination of  $H_{m0}$  and  $T_e$ .

**Table A.2 – Average capture length**

Significant wave height $H_m$ [m]	Average capture length for each bin [m]																		
	1,0	2,0	3,0	4,0	5,0	6,0	7,0	8,0	9,0	10,0	11,0	12,0	13,0	14,0	15,0	16,0	17,0	18,0	
7,5													3,88	3,15					
7,0													4,35	4,14		2,91			
6,5										5,00						3,18	2,70		
6,0									7,12			5,65	5,29	5,21	4,10	3,32			
5,5							5,59	8,73	9,73	8,85	7,52	6,71	6,44	5,35	4,53	3,34	2,98		
5,0							7,09	8,13	9,41	10,03	9,28	8,41	7,27	5,86	4,41	3,68	2,74		
4,5						2,90	5,59	8,54	9,30	10,09	9,85	8,94	7,18	5,55	4,53	3,22	2,95		
4,0						4,23	5,93	8,63	9,52	9,99	9,97	9,45	7,29	5,14	4,30	3,64			
3,5					1,34	2,90	5,94	8,54	9,52	10,03	10,02	9,42	7,38	5,70	4,46	3,47			
3,0					0,53	3,32	5,89	8,54	9,24	10,04	10,05	9,28	7,23	5,37	4,49		3,04		
2,5					1,23	3,01	6,04	8,17	9,41	10,10	10,03	9,56	7,30	5,49	4,66	3,51	3,02		
2,0					0,09	3,24	6,64	8,61	9,45	9,96	10,05	9,42	7,31	5,59	4,37	3,51	3,12		
1,5			0,01	0,20	1,07	2,69	6,35	8,39	9,47	10,06	10,05	9,45	7,16	5,51	4,53	3,59	3,21		
1,0			0,01	0,15	0,97	3,55	5,99	8,51	9,46	10,06	10,00	9,47	7,34		4,07	3,33			
0,5																			
		1,0	2,0	3,0	4,0	5,0	6,0	7,0	8,0	9,0	10,0	11,0	12,0	13,0	14,0	15,0	16,0	17,0	18,0
	Energy period $T_e$ [s]																		

The standard deviation, maximum and minimum values for each of the bins are included in Table A.3 through Table A.5 below. Table A.6 indicates the number of sample recorded which fall into each of the bins.

Table A.3 – Standard deviation of capture length

Significant wave height $H_m$ [m]	Standard deviation of capture length for each bin [m]																		
	1,0	2,0	3,0	4,0	5,0	6,0	7,0	8,0	9,0	10,0	11,0	12,0	13,0	14,0	15,0	16,0	17,0	18,0	
7,5																			
7,0													0,00	0,00				0,00	
6,5											0,00		0,00	0,00				0,22	0,00
6,0										0,59		0,00	0,23	0,00	0,18	0,39			
5,5						0,00	0,00	0,00	0,00	0,61	0,38	0,41	0,24	0,31	0,00	0,00	0,00	0,00	
5,0						0,00	0,00	0,00	0,36	0,24	0,41	0,58	0,59	0,25	0,18	0,00	0,00	0,00	
4,5						0,00	0,33	0,41	0,37	0,14	0,13	0,37	0,60	0,69	0,18	0,00	0,10		
4,0						0,00	0,00	0,13	0,21	0,25	0,12	0,49	0,67	0,32	0,32	0,06			
3,5						0,00	0,00	1,09	0,23	0,22	0,16	0,62	0,47	0,39	0,09	0,17			
3,0						0,00	0,36	0,86	0,00	0,28	0,19	0,15	0,58	0,60	0,31	0,19		0,00	
2,5						0,39	0,91	0,64	0,78	0,29	0,19	0,14	0,46	0,65	0,50	0,00	0,23	0,00	
2,0						0,00	0,62	0,82	0,71	0,46	0,25	0,24	0,14	0,51	0,72	0,49	0,29	0,25	0,00
1,5					0,00	0,00	0,52	0,95	0,58	0,46	0,23	0,20	0,12	0,58	0,51	0,41	0,00	0,00	0,06
1,0				0,00	0,00	0,24	0,67	0,60	0,52	0,30	0,21	0,15	0,63	0,60		0,00	0,00		
0,5																			
	1,0	2,0	3,0	4,0	5,0	6,0	7,0	8,0	9,0	10,0	11,0	12,0	13,0	14,0	15,0	16,0	17,0	18,0	
	Energy period $T_c$ [s]																		

Table A.4 – Maximum capture length

Significant wave height $H_m$ [m]	Maximum capture length for each bin [m]																		
	1,0	2,0	3,0	4,0	5,0	6,0	7,0	8,0	9,0	10,0	11,0	12,0	13,0	14,0	15,0	16,0	17,0	18,0	
7,5																			
7,0													3,88	3,15			2,91		
6,5										5,00			4,35	4,14			3,34	2,70	
6,0										7,72		5,65	5,49	5,21	4,28	3,59			
5,5								5,59	8,73	9,73	9,28	8,09	7,39	6,68	5,68	4,53	3,34	2,98	
5,0								7,09	8,13	9,73	10,21	9,64	9,23	7,96	6,04	4,53	3,68	2,74	
4,5						2,90	5,93	8,95	9,72	10,22	10,02	9,31	7,78	6,04	4,66	3,22	3,02		
4,0						4,23	5,93	8,73	9,73	10,22	10,12	1	8,05	5,36	4,53	3,68			
3,5						1,34	2,90	7,09	8,54	9,73	10,22	10,20	10,04	8,05	6,04	4,53	3,59		
3,0						0,53	3,53	6,81	8,54	9,73	10,22	10,20	10,04	8,05	5,68	4,66		3,04	
2,5						1,56	4,23	6,49	8,73	9,73	10,22	10,20	10,04	8,05	6,04	4,66	3,68	3,02	
2,0						0,09	1,56	4,23	7,09	8,95	9,73	10,22	10,04	8,05	6,04	4,66	3,68	3,12	
1,5						0,01	0,20	1,56	4,23	7,09	8,95	9,72	10,22	10,04	8,05	6,04	4,53	3,59	3,26
1,0						0,01	0,15	1,14	4,23	6,81	8,95	9,73	10,22	10,04	8,05	4,07	3,33		
0,5																			

Energy period  $T_e$  [s]



**Table A.5 – Minimum capture length**

Significant wave height $H_m^0$ [m]	Minimum capture length for each bin [m]																	
	1,0	2,0	3,0	4,0	5,0	6,0	7,0	8,0	9,0	10,0	11,0	12,0	13,0	14,0	15,0	16,0	17,0	18,0
7,5													3,88	3,15				
7,0													4,35	4,14			2,91	
6,5									5,00								3,03	2,70
6,0									6,30								3,04	
5,5									8,41								3,34	2,98
5,0									9,59								3,68	2,74
4,5									9,97								3,22	2,88
4,0									9,59								3,59	
3,5									9,59								3,35	
3,0									9,59									3,04
2,5									9,59									3,02
2,0									9,59									3,12
1,5									9,59									3,17
1,0									9,59									3,33
0,5									9,59									
	1,0	2,0	3,0	4,0	5,0	6,0	7,0	8,0	9,0	10,0	11,0	12,0	13,0	14,0	15,0	16,0	17,0	18,0

Energy period  $T_e$  [s]

Table A.6 – Number of data samples

Significant wave height $H_{m0}$ [m]	Count for each bin [-]																	
	1,0	2,0	3,0	4,0	5,0	6,0	7,0	8,0	9,0	10,0	11,0	12,0	13,0	14,0	15,0	16,0	17,0	18,0
7,5	0	0	0	0	0	0	0	0	0	0	0	0	0	0	0	0	0	0
7,0	0	0	0	0	0	0	0	0	0	0	0	0	1	1	0	1	0	0
6,5	0	0	0	0	0	0	0	0	0	1	0	0	1	1	0	2	1	0
6,0	0	0	0	0	0	0	0	0	4	0	1	6	1	1	4	2	0	0
5,5	0	0	0	0	0	1	1	1	2	6	6	3	3	3	1	1	2	0
5,0	0	0	0	0	0	1	1	5	7	4	5	8	2	2	2	1	0	0
4,5	0	0	0	0	0	1	3	3	4	5	4	5	2	2	2	2	0	0
4,0	0	0	0	0	0	1	1	2	6	11	9	10	8	2	2	2	0	0
3,5	0	0	0	1	1	4	1	10	10	11	10	7	4	2	2	0	0	0
3,0	0	0	0	1	3	6	2	8	17	16	14	8	3	3	0	1	0	0
2,5	0	0	0	3	4	2	2	9	12	15	11	10	3	1	3	1	0	0
2,0	0	0	0	1	3	4	6	7	13	17	18	11	3	5	2	1	0	0
1,5	0	0	1	1	3	6	8	6	11	14	11	11	12	7	1	1	2	0
1,0	0	0	1	1	2	3	7	5	11	15	8	9	12	0	1	1	0	0
0,5	0	0	0	0	0	0	0	0	0	0	0	0	0	0	0	0	0	0
	1,0	2,0	3,0	4,0	5,0	6,0	7,0	8,0	9,0	10,0	11,0	12,0	13,0	14,0	15,0	16,0	17,0	18,0
	Energy period $T_e$ [s]																	

The wave energy flux for each bin in the above scatter is calculated using a Jonswap spectrum, with gamma of 3 and the  $H_{m0}$  and  $T_e$  corresponding to the bin centres. The capture length and wave energy flux are used to calculate the WEC power in each bin.

**Table A.7 – Power matrix**

		Average wave energy converter power for each bin [kW]																																					
		7,5	7,0	6,5	6,0	5,5	5,0	4,5	4,0	3,5	3,0	2,5	2,0	1,5	1,0	0,5	1,0	2,0	3,0	4,0	5,0	6,0	7,0	8,0	9,0	10,0	11,0	12,0	13,0	14,0	15,0	16,0	17,0	18,0					
Significant wave height $H_m$ [m]	7,5																	1 211,30		1 060,76										1 120,15									
	7,0																	1 173,46		1 200,68											1 054,79		951,25						
	6,5																	1 141,02																					
	6,0																1 258,33		1 197,27	1 214,14	1 287,20											937,54							
	5,5																580,70	1 036,33	1 227,81	1 194,43	1 112,58											1 008,58		793,49		751,51			
	5,0																608,92	797,68	1 252,36	1 237,23	1 006,19											810,69		722,56		571,68			
	4,5																172,69	389,05	1 076,69	1 066,30	771,80											674,70		511,71		498,93			
	4,0																199,46	325,67	860,53	890,00	564,38											506,42		456,73					
	3,5																40,28	250,07	662,39	679,15	479,44											402,49		333,76					
	3,0																11,60	182,03	487,97	491,87	331,93										297,36				228,28				
	2,5																18,92	129,66	338,38	351,76	235,52										214,17		172,04		157,45				
	2,0																0,69	91,22	216,90	221,84	153,69										128,66		110,06		103,94				
	1,5																0,88	49,06	122,06	125,13	85,23										75,02		63,43		60,33				
	1,0																0,30	20,56	53,98	55,78	26,13									29,96				26,13					
	0,5																																						
			<b>1,0</b>	<b>2,0</b>	<b>3,0</b>	<b>4,0</b>	<b>5,0</b>	<b>6,0</b>	<b>7,0</b>	<b>8,0</b>	<b>9,0</b>	<b>10,0</b>	<b>11,0</b>	<b>12,0</b>	<b>13,0</b>	<b>14,0</b>	<b>15,0</b>	<b>16,0</b>	<b>17,0</b>	<b>18,0</b>	<b>Energy period <math>T_e</math> [s]</b>																		

## Annex B (normative)

### Method for power loss compensation where the measurement point is located on shore

#### B.1 Single-line diagram

A single-line diagram of a typical grid connected WEC system is indicated in Figure B.1.

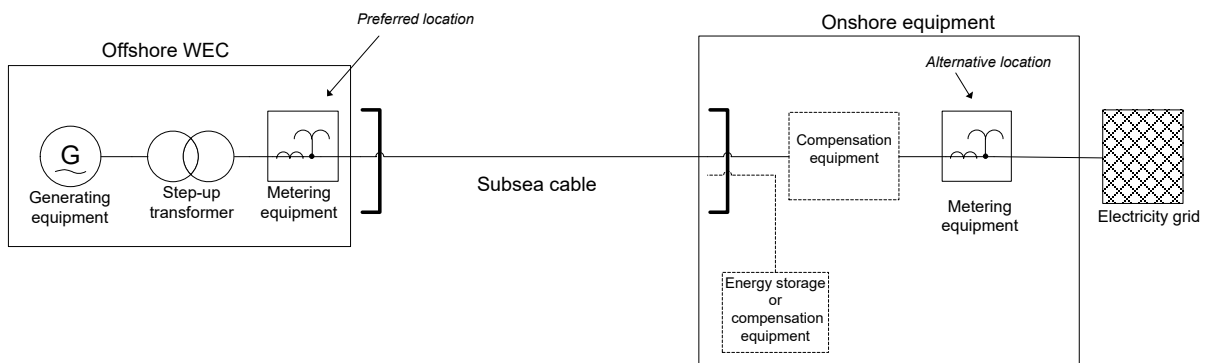

**Figure B.1 – Location options for metering equipment**

Ideally, power output should be measured at the output terminals of the WEC. This is referred to as the “Preferred Location” in Figure B.1. If the metering equipment is located on the generator side of the WEC step-up transformer, this shall be noted.

Some WECs use energy storage and/or compensation equipment that are external to the WEC itself but shall be considered as a part of it for the purposes of performance assessment. Typical locations for such equipment are indicated with broken lines. The compensation equipment may be installed in series or shunt with the power flow, and auxiliary energy storage equipment is typically installed in a shunt configuration. In such situations, or in situations where power measurement is only possible shore side, the WEC power should be measured at the output terminals of the compensation equipment wherever it is situated, or at the shore station incoming bus bars, where no compensation equipment is present. This is referred to as the “alternative location” in Figure B.1. In this case, losses due to cables and other components between the WEC system and the compensation equipment should be determined and the power output should be adjusted accordingly.

A methodology for losses incurred in a single connection cable is provided in the next section. If the connection equipment between the WEC system and the compensation equipment is more complex than this, the methodology for the power loss corrections should be fully explained in the file header and accompanied by supporting documentation as necessary.

#### B.2 Cable loss compensation

If the metering equipment is installed in the “alternative location” as illustrated in Figure B.1, then the losses in the cable shall be added to the power readings in order to give a realistic assessment of the performance of the WEC system. For loss purposes, the cable is modelled in positive sequence as shown in Figure B.2.  $R_{\text{cable}}$ ,  $X_{\text{cable}}$ , and  $C_{\text{cable}}$  represent the total positive sequence resistance, reactance, and line-to-line capacitance of the cable. These are usually provided by manufacturers on a per km basis, and shall be multiplied up by the cable length in km in order to yield the relevant total impedance values. The cable resistance will generally be determined from the AC resistance per km values provided by the manufacturer.

Skin effect can be taken into account if a detailed harmonic breakdown on the device output current is available. This is generally of negligible impact since harmonic filters at the output of power conversion equipment are designed to reduce the harmonic current components on the grid side to very small levels. These levels are regulated by the appropriate power quality standards in accordance with IEC 61000-3.

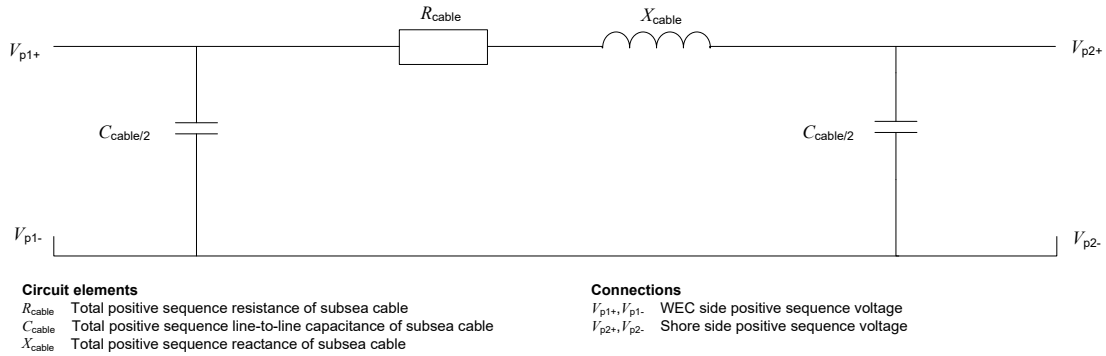

**Figure B.2 – Positive sequence cable model**

If a number of cables are connected in parallel between the offshore WEC system (or array) and the shore side metering station, the standard circuit theory should be used to derive the equivalent  $\pi$  circuit of the combination of cables.

In order to measure the power performance and determine cable losses, one of the following sets of measurements shall be made (utilising the instrumentation outlined in the next section):

- line-to-line r.m.s. voltage ( $U_{meas}$ ), line r.m.s. current ( $I_{meas}$ ), and the phase angle of each ( $\varphi_V, \varphi_I$ ) relative to a common reference signal or relative to each other;
- line-to-line r.m.s. voltage, line r.m.s. current and power factor ( $PF_{meas}$ );
- real power ( $P_{meas}$ ), reactive power ( $Q_{meas}$ ), and line-to-line r.m.s. voltage;
- the output of the WEC system ( $P_{genWEC}$ ) is then estimated by the following equation:

$$P_{genWEC} = P_{meas} + P_{loss} \quad (B.1)$$

where the measured real power is given directly by the power transducer or by appropriate combination of voltage, current, and power factor or phase angle, and where the cable loss component  $P_{loss}$  is given by:

$$P_{loss} = 3 \left[ \left( I_{meas} \cos \varphi_I - \frac{\omega C_{cable} U_{meas}}{2} \sin \varphi_V \right)^2 + \left( I_{meas} \sin \varphi_I + \frac{\omega C_{cable} U_{meas}}{2} \cos \varphi_V \right)^2 \right] R_{cable} \quad (B.2)$$

In the case of voltage, current and phase angle or power factor measurements. The factor  $\omega$  is the electrical radian frequency and is equal to  $2\pi$  times the electrical system frequency in Hz.

In the case where real and reactive power measurements are obtained, the current measurement and phase angles can be derived as follows:

$$I_{\text{meas}} = \sqrt{\frac{P_{\text{meas}}^2 + Q_{\text{meas}}^2}{3U_{\text{meas}}^2}} \quad (\text{B.3})$$

$$\varphi_V = 0 \quad \varphi_I = \arctan \frac{Q_{\text{meas}}}{P_{\text{meas}}} \quad (\text{B.4})$$

and substituted into the previous equation for calculating  $P_{\text{loss}}$ . An assumption in these calculations is that the system voltages and currents are balanced. Even in the presence of limited unbalance in the system, as permitted by the relevant national grid code, these equations are sufficient to estimate the cable loss compensation.

**Annex C**  
(normative)

**Evaluation of uncertainty**

**C.1 General**

The specification of the WEC power performance shall include an estimate of its uncertainty. The estimate shall be based on ISO/IEC Guide 98-1 and ISO/IEC Guide 98-3.

Following ISO/IEC Guide 98-1 and ISO/IEC Guide 98-3, there are two types of uncertainty: category A, the magnitude of which can be deduced from measurements, and category B, which are estimated by other means. For both categories uncertainties are expressed as standard deviations and are denoted standard uncertainties.

**C.2 Uncertainty analysis**

The measurands for the uncertainty analysis are the power matrix, determined by the measured and normalised values of electrical power production and sea-state parameters, and the estimated annual energy production. As a minimum the significant wave height and energy period shall be considered as measurands. Uncertainties in measurements are converted to uncertainties in these measurands by means of sensitivity factors.

Table C.1 contains a minimum list of uncertainty components that shall be included in the uncertainty analysis.

**Table C.1 – List of uncertainty components**

Measured/model parameter	Uncertainty component	Uncertainty category <sup>a</sup>
Significant wave height	Wave measuring instrument/model calibration	B
	Influence of moorings and/or other local effects on WMI	B
	Data acquisition system (e.g. sampling rate, windowing)	B
	Directional spectral analysis	B
	Variability of significant wave height	A
Energy period	Wave measuring instrument/model calibration	B
	Influence of moorings and/or other local effects on WMI	B
	Data acquisition system (e.g. sampling rate, windowing)	B
	Directional spectral analysis	B
	Strength of marine currents	B
	Variability of energy period	A
Wave power density	Water depth	A / B
	Water density	A / B
Electrical power	Current transformers	B
	Voltage transformers	B
	Power transducer or power measurement device	B
	Data acquisition system	B
	Variability of electrical power	A

<sup>a</sup> according to ISO/IEC Guide 98-1:2009 and ISO/IEC Guide 98-3:2008.

Where category A uncertainties are used the measurement and analysis methods shall be described. Where category B uncertainties are used the means by which the standard deviation has been determined shall be described.

NOTE The production of the power matrix implicitly assumes that the electrical power production is completely defined by the sea-state parameters used in the power matrix.

In general this is not the case. Other sea-state parameters will influence the power production but presently there is a lack of knowledge to determine what these parameters are and how they can be accounted for accurately in the power matrix.

The result is that the uncertainty is not associated with the measurement, but in the specification of the appropriate sea-state parameters. In general, this uncertainty can be expected to greater as the difference in conditions between those used to produce the power matrix and those in which the power matrix are used increases.



## Annex D (normative)

### Error analysis of the wave spatial transfer model

#### D.1 General

The term “spatial transfer model” in this Technical Specification refers to the use of analytical or numerical models to transfer measured wave parameters in one location to estimate wave parameters in another location at a known distance and direction from the location of the measured parameters. A spatial transfer model may not be required, see 5.2.5.

This Annex D covers a procedure for validation of a spatial transfer model for prediction of wave parameters at a specific location.

The method to validate the transfer model is provided in this Annex D.

#### D.2 Overview

##### D.2.1 Validation procedure

The validation involves the following steps:

- a) identify the specific parameters for validation;
- b) apply the transfer model to known measured data;
- c) measure performance of the transfer model as detailed in this Annex D;
- d) determine the suitability of the model by calculation the centre frequency fraction (CF).

##### D.2.2 Validation technique

Error ( $e$ ) is defined as: The predicted value ( $p$ ) of a parameter or variable minus the measured reference value ( $r$ ) of a parameter.

$$e_i = (p_i - r_i) \quad (D.1)$$

where

$e_i$  is the error of one sample record;

$p_i$  is the predicted value for sample record;

$r_i$  is the recorded value for the sample record;

$i$  is the sequential numerical identifier of an individual data point in a series of data.

Error percentage is defined as:

$$e_i = \frac{(p_i - r_i)}{r_i} \times 100 \quad (D.2)$$

The series mean (SM) or the mean value of a series of data points ( $y$ ) is defined as:

$$\bar{y} = \frac{1}{N} \sum_{i=1}^N y_i \quad (\text{D.3})$$

where

$y$  is the general value in a data set;

$N$  is the total number of data points in the series;

$i$  is the sequential numerical identifier of an individual data point in the series  $y$ .

Root Mean Square Error (RMSE) of a data set is defined as:

$$\text{RMSE} = \sqrt{\frac{1}{N} \sum_{i=1}^N e_i^2} \quad (\text{D.4})$$

The standard deviation (SD) of a data set is defined as:

$$\text{SD} = \sqrt{\frac{1}{N-1} \sum_{i=1}^N \left( e_i - \bar{e} \right)^2} \quad (\text{D.5})$$

Comparing the SM of the measured parameters to the parameters generated by the spatial transfer model and examining the RMSE and the SD provides an initial indication of the performance of the spatial transfer model.

The key statistic for meeting the performance requirements of this standard is the CF which is a measure of the frequency with which errors lie within a specified limit. For example, the calculated error between the measured and estimated parameter generated by the spatial transfer model shall be less than 10 % for 9 out of 10 data records to meet the current performance requirements for this standard.

Minimum thresholds for significant wave height and wave period should be set to keep error percentages manageable in small significant wave heights (e.g. less than 0,2 m) and short periods (below 2 s).

CF( $X$ ) is the centre frequency fraction (percentage) of errors that lie within the limits of  $\pm X$  %.

## Bibliography

IEC/TS 62600-1, *Marine energy – Wave, tidal and other water current converters – Part 1: Terminology*

ISO 19901-1:2005, *Petroleum and natural gas industries – Specific requirements for offshore structures – Part 1: Metocean design and operating considerations*

---

INTERNATIONAL ELECTROTECHNICAL COMMISSION

---

IEC TS 62600-100  
Edition 1.0 2012-08

MARINE ENERGY – WAVE, TIDAL AND OTHER WATER CURRENT CONVERTERS –  
Part 100: Electricity producing wave energy converters – Power performance assessment

**C O R R I G E N D U M 1**

*Replace the existing Formula (13), in 10.3, by the following new Formula (13):*

$$\text{MAEP}_{(\text{ALT})} = T \cdot \sum_{i=1}^{i=N} L_i \cdot J_i \cdot f_i \quad (13)$$



## Bureau of Indian Standards

BIS is a statutory institution established under the *Bureau of Indian Standards Act, 2016* to promote harmonious development of the activities of standardization, marking and quality certification of goods and attending to connected matters in the country.

### Copyright

BIS has the copyright of all its publications. No part of these publications may be reproduced in any form without the prior permission in writing of BIS. This does not preclude the free use, in the course of implementing the standard, of necessary details, such as symbols and sizes, type or grade designations. Enquiries relating to copyright be addressed to the Head (Publication & Sales), BIS.

### Review of Indian Standards

Amendments are issued to standards as the need arises on the basis of comments. Standards are also reviewed periodically; a standard along with amendments is reaffirmed when such review indicates that no changes are needed; if the review indicates that changes are needed, it is taken up for revision. Users of Indian Standards should ascertain that they are in possession of the latest amendments or edition by referring to the website-[www.bis.gov.in](http://www.bis.gov.in) or [www.standardsbis.in](http://www.standardsbis.in).

This Indian Standard has been developed from Doc No.: ETD 54 (24545).

### Amendments Issued Since Publication

Amend No.	Date of Issue	Text Affected

## BUREAU OF INDIAN STANDARDS

### Headquarters:

Manak Bhavan, 9 Bahadur Shah Zafar Marg, New Delhi 110002

Telephones: 2323 0131, 2323 3375, 2323 9402

Website: [www.bis.gov.in](http://www.bis.gov.in)

### Regional Offices:

	Telephones
Central : 601/A, Konnectus Tower -1, 6 <sup>th</sup> Floor, DMRC Building, Bhavbhuti Marg, New Delhi 110002	{ 2323 7617
Eastern : 8 <sup>th</sup> Floor, Plot No 7/7 & 7/8, CP Block, Sector V, Salt Lake, Kolkata, West Bengal 700091	{ 2367 0012 2320 9474
Northern : Plot No. 4-A, Sector 27-B, Madhya Marg, Chandigarh 160019	{ 265 9930
Southern : C.I.T. Campus, IV Cross Road, Taramani, Chennai 600113	{ 2254 1442 2254 1216
Western : 5 <sup>th</sup> Floor/ MTNL CETTM Technology Street, Hiranandani Gardens, Powai, Mumbai 400076	{ 2570 0030 2570 2715

**Branches :** AHMEDABAD, BENGALURU, BHOPAL, BHUBANESHWAR, CHANDIGARH, CHENNAI, COIMBATORE, DEHRADUN, DELHI, FARIDABAD, GHAZIABAD, GUWAHATI, HARYANA (CHANDIGARH), HUBLI, HYDERABAD, JAIPUR, JAMMU, JAMSHEDPUR, KOCHI, KOLKATA, LUCKNOW, MADURAI, MUMBAI, NAGPUR, NOIDA, PARWANOO, PATNA, PUNE, RAIPUR, RAJKOT, SURAT, VIJAYAWADA.