



इलेक्ट्रिक पावर सिस्टम और एसोसिएटेड
इंटरफेस के साथ वितरित ऊर्जा संसाधनों को
इंटरकनेक्ट करने वाले उपस्कर के लिए
अनुरूपता परीक्षण प्रक्रियाएं

(IEEE Std 1547.1™ : 2020, संशोधित)

Conformance Test Procedures for
Equipment Interconnecting
Distributed Energy Resources with
Electric Power Systems and
Associated Interfaces

(IEEE Std 1547.1™ : 2020, Mod)

ICS 29.240.01

© BIS 2024



IEEE

Adoption of an
IEEE Standard



भारतीय मानक ब्यूरो

BUREAU OF INDIAN STANDARDS
मानक भवन, 9 बहादुर शाह ज़फर मार्ग, नई दिल्ली - 110002
MANAK BHAVAN, 9 BAHADUR SHAH ZAFAR MARG
NEW DELHI - 110002

www.bis.gov.in www.standardsbis.in

NATIONAL FOREWORD

This Indian Standard which is modified adoption of International Publication IEEE Std 1547.1TM : 2020 'IEEE standard conformance test procedures for equipment interconnecting distributed energy resources with electric power systems and associated interfaces' issued by the Institute of Electrical and Electronics Engineers was adopted by the Bureau of Indian Standards on the recommendation of the Grid Integration of Renewables Sectional Committee and approval of the Electrotechnical Division Council.

This standard is made available under licence from IEEE and is an adoption of IEEE Std 1547.1TM : 2020 'IEEE standard conformance test procedures for equipment interconnecting distributed energy resources with electric power systems and associated interfaces', 445 Hoes Lane Piscataway, NJ, 08854, USA.

This standard is only valid in India as an Indian National Standard. No changes have been made to the adopted IEEE standard except those that may be included as country-specific changes in a front matter or an attached informative annexure. India specific changes have been made to the adopted IEEE standard as outlined in [National Annex K](#).

The text of IEEE standard has been approved as suitable for publication as an Indian Standard without deviations. Certain terminology and conventions are however not identical to those used in Indian Standards. Attention is particularly drawn to the following:

- a) Wherever the words 'IEEE Standard' appear referring to this standard, they should be read as 'Indian Standard'; and

In this adopted standard, reference appears to International Standards for which Indian Standards also exist. The corresponding Indian Standards, which are to be substituted, are listed below along with their degree of equivalence for the editions indicated:

<i>International Standard</i>	<i>Corresponding Indian Standard</i>	<i>Degree of Equivalence</i>
IEEE Std 1547™ IEEE standard for interconnection and interoperability of distributed energy resources with associated electric power systems interfaces	IS 18968 : 2024/IEEE 1547 : 2018 Interconnection and interoperability of distributed energy resources with associated electric power systems interfaces	modified

The Committee has reviewed the provisions of the following international standards referred in this adopted standard and decided that they are acceptable for use in conjunction with this standard.

<i>International Standard</i>	<i>Title</i>
DNP3	Application note AN2018-001, DNP3 profile for communications with distributed energy resources
IEC 61000-3-6	Electromagnetic compatibility (EMC) — Part 3-6: Limits — Assessment of emission limits for the connection of distorting installations to MV, HV and EHV power systems
IEC/IEEE 62271-37-013	International standard for high-voltage switchgear and control gear — Part 37-013: Alternating-current generator circuit-breakers

IEEE C37.04™-2018	IEEE standard for ratings and requirements for ac high-voltage circuit breakers with rated maximum voltage above 1000 V
IEEE Std C37.09™-2018	IEEE standard test procedures for AC high-voltage circuit breakers with rated maximum voltage above 1000 V
IEEE Std C37.60™	IEEE/IEC International Standard — High-voltage switchgear and controlgear — Part 111: Automatic circuit reclosers and fault interrupters for alternating current systems up to 38 kV
IEEE Std C37.90.1™	IEEE standard for surge withstand capability (SWC) tests for relays and relay systems associated with electric power apparatus
IEEE Std C37.90.2™	IEEE standard for withstand capability of relay systems to radiated electromagnetic interference from transceivers
IEEE Std C37.111™/ IEC 60255-24	IEEE/IEC Measuring relays and protection equipment — Part 24: Common format for transient data exchange (COMTRADE) for power systems
IEEE Std C62.41.2™	IEEE recommended practice on characterization of surges in low-voltage (1000 V and less) AC power circuits
IEEE Std C62.45™	IEEE recommended practice on surge testing for equipment connected to low-voltage (1000 V and less) AC power circuits
IEEE Std C62.92.1™	IEEE guide for the application of neutral grounding in electrical utility systems — Part I: Introduction
IEEE C62.92.6™	IEEE guide for application of neutral grounding in electrical utility systems — Part VI: Systems supplied by current-regulated sources
IEEE Std 112™	IEEE Standard test procedure for polyphase induction motors and generators
IEEE Std 115™	IEEE Guide for test procedures for synchronous machines — Part I: Acceptance and performance testing and Part II: Test procedures and parameter determination for dynamic analysis
IEEE Std 421.5™	IEEE recommended practice for excitation system models for power system stability studies
IEEE Std 1159.3™	IEEE recommended practice for power quality data interchange format (PQDIF)
IEEE Std 1815™-2012	IEEE standard for electric power systems communications-distributed network protocol (DNP3)
IEEE Std 2030.5™-2018	IEEE standard for smart energy profile application protocol

Important Notices and Disclaimers Concerning IEEE Standards Documents

IEEE documents are made available for use subject to important notices and legal disclaimers. These notices and disclaimers, or a reference to this page, appear in all standards and may be found under the heading “Important Notices and Disclaimers Concerning IEEE Standards Documents.” They can also be obtained on request from IEEE or viewed at <http://standards.ieee.org/ipr/disclaimers.html>.

Notice and Disclaimer of Liability Concerning the Use of IEEE Standards Documents

IEEE Standards documents (standards, recommended practices, and guides), both full-use and trial-use, are developed within IEEE Societies and the Standards Coordinating Committees of the IEEE Standards Association (“IEEE SA”) Standards Board. IEEE (“the Institute”) develops its standards through a consensus development process, approved by the American National Standards Institute (“ANSI”), which brings together volunteers representing varied viewpoints and interests to achieve the final product. IEEE Standards are documents developed through scientific, academic, and industry-based technical working groups. Volunteers in IEEE working groups are not necessarily members of the Institute and participate without compensation from IEEE. While IEEE administers the process and establishes rules to promote fairness in the consensus development process, IEEE does not independently evaluate, test, or verify the accuracy of any of the information or the soundness of any judgments contained in its standards.

IEEE Standards do not guarantee or ensure safety, security, health, or environmental protection, or ensure against interference with or from other devices or networks. Implementers and users of IEEE Standards documents are responsible for determining and complying with all appropriate safety, security, environmental, health, and interference protection practices and all applicable laws and regulations.

IEEE does not warrant or represent the accuracy or content of the material contained in its standards, and expressly disclaims all warranties (express, implied and statutory) not included in this or any other document relating to the standard, including, but not limited to, the warranties of: merchantability; fitness for a particular purpose; non-infringement; and quality, accuracy, effectiveness, currency, or completeness of material. In addition, IEEE disclaims any and all conditions relating to: results; and workmanlike effort. IEEE standards documents are supplied “AS IS” and “WITH ALL FAULTS.”

Use of an IEEE standard is wholly voluntary. The existence of an IEEE standard does not imply that there are no other ways to produce, test, measure, purchase, market, or provide other goods and services related to the scope of the IEEE standard. Furthermore, the viewpoint expressed at the time a standard is approved and issued is subject to change brought about through developments in the state of the art and comments received from users of the standard.

In publishing and making its standards available, IEEE is not suggesting or rendering professional or other services for, or on behalf of, any person or entity nor is IEEE undertaking to perform any duty owed by any other person or entity to another. Any person utilizing any IEEE Standards document, should rely upon his or her own independent judgment in the exercise of reasonable care in any given circumstances or, as appropriate, seek the advice of a competent professional in determining the appropriateness of a given IEEE standard.

IN NO EVENT SHALL IEEE BE LIABLE FOR ANY DIRECT, INDIRECT, INCIDENTAL, SPECIAL, EXEMPLARY, OR CONSEQUENTIAL DAMAGES (INCLUDING, BUT NOT LIMITED TO: PROCUREMENT OF SUBSTITUTE GOODS OR SERVICES; LOSS OF USE, DATA, OR PROFITS; OR BUSINESS INTERRUPTION) HOWEVER CAUSED AND ON ANY THEORY OF LIABILITY, WHETHER IN CONTRACT, STRICT LIABILITY, OR TORT (INCLUDING NEGLIGENCE OR OTHERWISE) ARISING IN ANY WAY OUT OF THE PUBLICATION, USE OF, OR RELIANCE UPON ANY STANDARD, EVEN IF ADVISED OF THE POSSIBILITY OF SUCH DAMAGE AND REGARDLESS OF WHETHER SUCH DAMAGE WAS FORESEEABLE.

Translations

The IEEE consensus development process involves the review of documents in English only. In the event that an IEEE standard is translated, only the English version published by IEEE should be considered the approved IEEE standard.

Official statements

A statement, written or oral, that is not processed in accordance with the IEEE SA Standards Board Operations Manual shall not be considered or inferred to be the official position of IEEE or any of its committees and shall not be considered to be, or be relied upon as, a formal position of IEEE. At lectures, symposia, seminars, or educational courses, an individual presenting information on IEEE standards shall make it clear that his or her views should be considered the personal views of that individual rather than the formal position of IEEE.

Comments on standards

Comments for revision of IEEE Standards documents are welcome from any interested party, regardless of membership affiliation with IEEE. However, IEEE does not provide consulting information or advice pertaining to IEEE Standards documents. Suggestions for changes in documents should be in the form of a proposed change of text, together with appropriate supporting comments. Since IEEE standards represent a consensus of concerned interests, it is important that any responses to comments and questions also receive the concurrence of a balance of interests. For this reason, IEEE and the members of its societies and Standards Coordinating Committees are not able to provide an instant response to comments or questions except in those cases where the matter has previously been addressed. For the same reason, IEEE does not respond to interpretation requests. Any person who would like to participate in revisions to an IEEE standard is welcome to join the relevant IEEE working group.

Comments on standards should be submitted to the following address:

Secretary, IEEE SA Standards Board
445 Hoes Lane
Piscataway, NJ 08854 USA

Laws and regulations

Users of IEEE Standards documents should consult all applicable laws and regulations. Compliance with the provisions of any IEEE Standards document does not imply compliance to any applicable regulatory requirements. Implementers of the standard are responsible for observing or referring to the applicable regulatory requirements. IEEE does not, by the publication of its standards, intend to urge action that is not in compliance with applicable laws, and these documents may not be construed as doing so.

Copyrights

IEEE draft and approved standards are copyrighted by IEEE under US and international copyright laws. They are made available by IEEE and are adopted for a wide variety of both public and private uses. These include both use, by reference, in laws and regulations, and use in private self-regulation, standardization, and the promotion of engineering practices and methods. By making these documents available for use and adoption by public authorities and private users, IEEE does not waive any rights in copyright to the documents.

Photocopies

Subject to payment of the appropriate fee, IEEE will grant users a limited, non-exclusive license to photocopy portions of any individual standard for company or organizational internal use or individual, non-commercial use only. To arrange for payment of licensing fees, please contact Copyright Clearance Center, Customer Service, 222 Rosewood Drive, Danvers, MA 01923 USA; +1 978 750 8400. Permission to photocopy portions of any individual standard for educational classroom use can also be obtained through the Copyright Clearance Center.

Updating of IEEE Standards documents

Users of IEEE Standards documents should be aware that these documents may be superseded at any time by the issuance of new editions or may be amended from time to time through the issuance of amendments, corrigenda, or errata. An official IEEE document at any point in time consists of the current edition of the document together with any amendments, corrigenda, or errata then in effect.

Every IEEE standard is subjected to review at least every 10 years. When a document is more than 10 years old and has not undergone a revision process, it is reasonable to conclude that its contents, although still of some value, do not wholly reflect the present state of the art. Users are cautioned to check to determine that they have the latest edition of any IEEE standard.

In order to determine whether a given document is the current edition and whether it has been amended through the issuance of amendments, corrigenda, or errata, visit IEEE Xplore at <http://ieeexplore.ieee.org/> or contact IEEE at the address listed previously. For more information about the IEEE SA or IEEE's standards development process, visit the IEEE SA Website at <http://standards.ieee.org>.

Errata

Errata, if any, for IEEE standards can be accessed via <https://standards.ieee.org/standard/index.html>. Search for standard number and year of approval to access the web page of the published standard. Errata links are located under the Additional Resources Details section. Errata are also available in IEEE Xplore: <https://ieeexplore.ieee.org/browse/standards/collection/ieee/>. Users are encouraged to periodically check for errata.

Patents

Attention is called to the possibility that implementation of this standard may require use of subject matter covered by patent rights. By publication of this standard, no position is taken by the IEEE with respect to the existence or validity of any patent rights in connection therewith. If a patent holder or patent applicant has filed a statement of assurance via an Accepted Letter of Assurance, then the statement is listed on the IEEE SA Website at <https://standards.ieee.org/about/sasb/patcom/patents.html>. Letters of Assurance may indicate whether the Submitter is willing or unwilling to grant licenses under patent rights without compensation or under reasonable rates, with reasonable terms and conditions that are demonstrably free of any unfair discrimination to applicants desiring to obtain such licenses.

Essential Patent Claims may exist for which a Letter of Assurance has not been received. The IEEE is not responsible for identifying Essential Patent Claims for which a license may be required, for conducting inquiries into the legal validity or scope of Patents Claims, or determining whether any licensing terms or conditions provided in connection with submission of a Letter of Assurance, if any, or in any licensing agreements are reasonable or non-discriminatory. Users of this standard are expressly advised that determination of the validity of any patent rights, and the risk of infringement of such rights, is entirely their own responsibility. Further information may be obtained from the IEEE Standards Association.

Participants

At the time this standard conformance test procedures document was completed, the IEEE Standards Coordinating Committee on Fuel Cells, Photovoltaics, Dispersed Generation, and Energy Storage had the following membership:

Mark Siira, *Chair*
Babak Enayati, *Vice Chair*
Jens C. Boemer, *Secretary*
Charles K. Vartanian, *Treasurer*
Wayne Stec, *Technical Writer*

Curtis Ashton
Thomas Basso
Leo Casey
Mohla Daleep
Frank Goodman

Anderson Hoke
Ben Kazimier
Debra Lew
David Narang

Michael (Mike) Ropp
Janette Sandberg
Robby Simpson
Reigh Walling
Tim Zgonena

At the time this standard was completed, the Standard Conformance Test Procedures for Equipment Interconnecting Distributed Energy Resources with Electric Power Systems and Associated Interfaces Working Group (P1547.1 WG) of the Standard Coordinating Committee 21 (SCC21) on Fuel Cells, Photovoltaics, Dispersed Generation, and Energy Storage had the following membership:

Anderson Hoke, *Chair*
Babak Enayati, Karl Schoder, Tim Zgonena, *Vice Chairs*
Jeannie Amber, *Secretary*

Subgroup Chairs

Marcelo Algrain, Jeannie Amber, John Berdner, Jens C. Boemer, Jonathan Ehlmann, Bob Fox, Haile Gashaw, Sigifredo Gonzalez, Anderson Hoke, Soonwook Hong, Gregory Kern, Jesse Leonard, Shazreen Meor Danial, Michael (Mike) Ropp, Karl Schoder, Brian Seal, Mark Siira, Wayne Stec, Reigh Walling, Robert White

Marcelo Algrain
Danial Arjona
Dillon Ashton
Thomas Basso
John Berdner
George Bern
David Blackledge
Jason Bobruk
Jens C. Boemer
Richard Bravo
Robert Bridges
Michael Brigandi
Paul Brucke
Ken Brunkenhoefer
Sean Carr
Sudipta Chakraborty
Ke Chen
Nancy Connelly
Patrick Dalton
Mamadou Diong
Benjamin Ealey
Anthony Eason
Christian Eder

Jonathan Ehlmann
Babak Enayati
Brian Espiritu
Wesley Fassnacht
Bob Fox
Haile Gashaw
Ken Gebauer
Sigifredo Gonzalez
Thomas Gwinn
Keith Harley
Kyle Hawkins
Anderson Hoke
Soonwook Hong
Keith Houser
Aminul Huque
James Hurtt
Ruben Inzunza
Mike Jensen
Bob Jordan
Prashant Kansal
Scott Karpel
Gregory Kern
Paul Krell

Jesse Leonard
Haiwen Liu
Brian Lydic
Fumio Masuda
James Mater
Shazreen Meor Danial
Jonathan Meyer
Lyman Morikawa
Edward Morrow
Naga Raja Rao
David Narang
Cuong Nguyen
Marty Page
Jeannie Amber
Robert Preus
Rodrigo Roe
Michael (Mike) Ropp
John Ruddick
Nachum Sadan
Roger Salas
Janette Sandberg
Joe Schaefer
Karl Schoder

Rich Scroggins
Brian Seal
Ronald Shipman
Mark Siira
Mark Smith
Gary Smullin

Lincoln Sprague
James Sprecher
Wayne Stec
Tim Sullivan
Chase Sun

Charlie Vartanian
Reigh Walling
Robert White
Kevin Whitener
Stephen Wurmlinger
Tim Zgonena

The following working group members comprised the comment resolution team responsible for addressing ballot comments:

Marcelo Algrain
Jeannie Amber
John Berdner
Jens C. Boemer
Nancy Connelly
Jonathan Ehlmann
Haile Gashaw
Sigifredo Gonzalez

Anderson Hoke
Gregory Kern
Paul Krell
Jesse Leonard
Shazreen Meor Danial
Michael (Mike) Ropp
David Narang

Karl Schoder
Brian Seal
Mark Siira
Wayne Stec
Reigh Walling
Robert White
Stephen Wurmlinger
Tim Zgonena

The following members of the individual balloting committee voted on this standard. Balloters may have voted for approval, disapproval, or abstention.

Mark Ahlstrom
Ali Al Awazi
Mihaela Albu
Roy Alexander
Marcelo Algrain
Saleman Alibhay
Steven Allmond
Chris Ambrose
Jay Anderson
Daniel Arjona
Curtis Ashton
Mark Baldassari
Thomas Barnes
Paul Barnhart
Frank Basciano
Michael Basler
Thomas Basso
Brian Baumgart
David Beach
John Berdner
Thomas Blackburn
David Blackledge
Robin Blanton
William Bloethe
Jens Boemer
Edwin Briggs
David Brown
Gustavo Brunello
Demetrio Bucaneg, Jr
Jeffrey Burnworth
William Byrd
Eldridge Byron
John Calvin
Mario Manana Canteli
Paul Cardinal
Clint Carne
Sean Carr
Leo Casey
Sudipta Chakraborty

Wen-Kung Chang
Ke Chen
Nancy Chilton
Frances Cleveland
Kent Coldsnow
Nancy Connelly
Larry Conrad
Stephen Conrad
Luis Coronado
Randall Crellin
Timothy Croushore
Curtis Cryer
Robert Cummings
Patrick Dalton
Ratan Das
Mamadou Diong
Michael Dood
Neal Dowling
Herbert Dreyer
Paul Duncan
Donald Dunn
David Dunne
Benjamin Ealey
Christian Eder
Antti Eerola
Jonathan Ehlmann
Zakia El Omari
Babak Enayati
Peter Evans
Kevin Fellhoelter
Jorge Fernandez Daher
Curtis Fischer
Keith Flowers
Rostyslaw Fostiak
Robert Fox
Raymond Frazier, III
Hailegebriel Gashaw
Ken Gebauer
Paul Gingrich

Tim Godfrey
Jalal Gohari
Edwin Goodwin
Lou Grahor
Joseph Grappe
Stephen Grier
Randall Groves
Joshua Hambrick
John Harley
Robert Harris
Kyle Hawkings
Thomas Hawkins
Jeffrey Helzer
Mariana Hentea
Lee Herron
Michael Higginson
Werner Hoelzl
Robert Hoerauf
Anderson Hoke
Eric Hope
Lawrence Hopkins
Philip Hopkinson
Todd Irwin
Dmitry Ishchenko
Richard Jackson
Anthony Johnson
Gerald Johnson
Geza Joos
Innocent Kamwa
Robert Kazimier
Peter Kelly
Chad Kennedy
Gael Kennedy
Sheldon Kennedy
Gregory Kern
Yuri Khersonsky
Amin Khodaei
James Kinney
Chad Knutson

Boris Kogan
Lawrence Kotewa
Paul Krell
Jim Kulchisky
Michael Lafond
Chung-Yiu Lam
Robert Landman
Raluca Lascu
John Leach
Wei-Jen Lee
Jesse Leonard
Brian Lydic
Jose Marrero
Todd Martin
Sal Martino
James Mater
Omar Mazzoni
William McBride
Jeffrey McElray
Hank McGlynn
Brian McMillan
Jonathan Meyer
Peter Meyer
Bob Micek
James Mirabile
Andrew Miraldi
Jeff Mizener
Lyman Morikawa
Edward Morrow
Charles Morse
David Mueller
Adi Mulawarman
R. Murphy
Mark Murray
Bruce Muschlitz
K. R. M. Nair
David Narang
Alexandre Nassif
Cuong Nguyen
James Niemira
Joe Nims
Chenhui Niu
Matthew Norwalk

Gregory Olson
Mohamed Osman
Lorraine Padden
Bansi Patel
Stephen Pell
Jeannie Piekarz
Prasad Pmsvsv
Lakshman Raut
James Reilly
Caryn Riley
Charles Rogers
Michael Ropp
Edward Ruck
John Ruddock
Nachum Sadan
Christian Sanchez
Chester Sandberg
Janette Sandberg
Kenneth Sanders
Steven Sano
Bartien Sayogo
Joseph Schaefer
Carl Schneider
Karl Schoder
Ulrich Schwabe
Brian Seal
Christopher Searles
Kenneth Sedziol
Daniel Seidel
Robert Seitz
John Seuss
Nikunj Shah
Frank Siepker
Michael Sigmon
Mark Siira
Hyeong Sim
Jerry Smith
Gary Smullin
Joseph Sowell
Lincoln Sprague
Allan St Peter
Wayne Stec

Marcus Steel
Michael Stephens
Joseph Stevens
Clayton Stice
K. Stump
Paul Sullivan
Chase Sun
David Tepen
Michael Thesing
Sylvester Toe
James Tomaseski
Francois Trichon
Craig Turner
Demetrios Tziouvaras
Eric Udren
Philip Undercuffler
Timothy Unruh
James Van De Ligt
Benton Vandiver
Luis Vargas
Charlie Vartanian
S. Venkata
John Vergis
Michael Wactor
Simon Wall
Reigh Walling
John Wang
Daniel Ward
Keith Waters
John Webb
Kenneth White
Robert White
Kevin Whitener
Allen Windhorn
Philip Winston
Nicolas Wrathall
Stephen Wurmlinger
Oren Yuen
Nicholas Zagrodnik
David Zech
Tim Zgonena
Danish Zia
Ahmed Zobaa

When the IEEE SA Standards Board approved this standard on 5 March 2020, it had the following membership:

Gary Hoffman, *Chair*
Jon Walter Rosdahl, *Vice Chair*
Jean-Philippe Faure, *Past Chair*
Konstantinos Karachalios, *Secretary*

Ted Burse
J. Travis Griffith
Grace Gu
Guido R. Hiertz
Joseph L. Koepfinger*
John D. Kulick

David J. Law
Howard Li
Dong Liu
Kevin Lu
Paul Nikolich
Damir Novosel
Dorothy Stanley

Mehmet Ulema
Lei Wang
Sha Wei
Philip B. Winston
Daidi Zhong
Jingyi Zhou

*Member Emeritus

Contents

1. Overview	1
1.1 General	1
1.2 Scope	1
1.3 Purpose	2
1.4 Limitations	2
1.5 Compliance review	2
2. Normative references	2
3. Definitions, abbreviations, and acronyms	4
3.1 Definitions	4
3.2 Abbreviations and acronyms	7
4. General requirements	8
4.1 General	8
4.2 Test result accuracy	9
4.3 Testing environment	10
4.4 Product information	10
4.5 Test reports	11
4.6 Testing equipment requirements	14
4.7 Requirements on <i>type test</i> order and selection of DER sample(s)	14
4.8 <i>Intentional island-capable</i> DERs and devices	15
5. Type tests	15
5.1 General	15
5.2 Priority of responses	16
5.3 Temperature stability	16
5.4 Test for response to voltage disturbances	18
5.5 Test for response to frequency disturbances	38
5.6 Enter service	49
5.7 Synchronization	51
5.8 Interconnection integrity	57
5.9 Limitation of dc injection for inverters	60
5.10 Unintentional islanding	61
5.11 Open phase	78
5.12 Current distortion	80
5.13 Limit active power	83
5.14 Voltage regulation	85
5.15 Frequency support	104
5.16 Test for prioritization of DER responses	109
5.17 Limitation of overvoltage contribution	112
5.18 Fault current tests	117
5.19 Persistence of DER parameter settings	121
6. Interoperability tests	124
6.1 Overview	124
6.2 Interoperability testing approach	125
6.3 General test procedures	125
6.4 Nameplate data test	126
6.5 Configuration information test	126
6.6 Monitoring information test	127

6.7 Management information test	126
6.8 Specific protocol mappings	126
7. Production tests	141
7.1 Introduction	141
7.2 Response to abnormal voltage	141
7.3 Response to abnormal frequency	142
7.4 Documentation.....	142
8. <i>DER evaluations and commissioning tests</i>	143
8.1 Introduction	143
8.2 PoC-Unit: Basic <i>DER evaluations and commissioning tests</i> for <i>DER units and DER systems</i> with RPA at PoC.....	150
8.3 PoC-Composite: Detailed <i>DER evaluations and commissioning tests</i> for <i>DER composite</i> with RPA at PoC.....	161
8.4 PCC-System: Basic <i>DER evaluations and commissioning tests</i> for <i>DER units and DER systems</i> with RPA at PCC.....	185
8.5 PCC-Composite: Detailed <i>DER evaluations and commissioning tests</i> for <i>DER composite</i> with RPA at PCC.....	202
9. Periodic interconnection tests.....	225
Annex A (normative) Test signals.....	226
A.1 Introduction	226
A.2 Illustration of <i>clearing time</i>	226
A.3 Step change test signal—General	227
A.4 Rate limited step function	230
A.5 Reverse or minimum import power magnitude test (ramp function).....	232
A.6 Reverse or minimum import power time test (step function)	233
Annex B (normative) Results reporting format template	236
Annex C (informative) Calculation of test criteria considering uncertainty in input and output.....	239
Annex D (informative) Unintentional islanding of DER.....	241
Annex E (informative) IEC 61850-7-420 information model usage	243
E.1 General communication commissioning	243
E.2 Nameplate data test	243
E.3 Configuration information.....	245
E.4 Monitoring information.....	246
E.5 Constant power factor	246
E.6 Voltage-reactive power	247
E.7 Active power-reactive power	247
E.8 Constant reactive power.....	247
E.9 Voltage-active power	248
E.10 Voltage trip	248
E.11 Momentary cessation.....	248
E.12 Frequency trip	249
E.13 Frequency droop (frequency-watt).....	249
E.14 Enter service.....	250
E.15 Limit maximum active power	250
Annex F (informative) Hardware-in-the-loop based testing.....	251
F.1 Terminology	251

F.2 Controller hardware-in-the-loop testing for <i>supplemental DER devices</i>	253
F.3 Additional information on PHIL test setup requirements in testing unintentional islanding.....	255
F.4 Measuring impedance characteristics	256
Annex G (informative) Short circuit simulator.....	258
G.1 Purpose	258
G.2 Procedure	258
G.3 Requirements	260
G.4 Criteria	260
G.5 Comments	260
Annex H (informative) Testing using a source other than a programmable ac power supply	261
H.1 Testing using a source other than a programmable ac power supply.....	261
Annex I (informative) Closed-loop and open-loop time responses	263
Annex J (informative) Bibliography.....	267

*Indian Standard***CONFORMANCE TEST PROCEDURES FOR EQUIPMENT
INTERCONNECTING DISTRIBUTED ENERGY
RESOURCES WITH ELECTRIC POWER
SYSTEMS AND ASSOCIATED INTERFACES****1. Overview****1.1 General**

This standard provides tests and procedures for verifying conformance of *distributed energy resources* (DERs) to IEEE Std 1547™.¹ It is recognized that a DER can be a single device providing all required functions or an assembly of components, each having limited functions and capabilities. Components having limited functions and capabilities shall be tested for those functions in accordance with this standard. Conformance may be established through a combination of type, production, and *commissioning tests* as well as DER *design evaluations* and DER *installation evaluations*. Additionally, conformance to IEEE Std 1547 may require periodic tests.

This standard also includes [Annex A](#), which describes normative test signals and ramp functions used in conducting some tests. Information on where to find the test results reporting template (a separate document) is provided in [Annex B](#). Additionally, [Annex C](#) through [Annex J](#) provide informative content that may be helpful in implementing this standard, but that is not required to implement the procedures defined in this standard.

1.2 Scope

This standard specifies the type, production, commissioning, and periodic tests and evaluations that shall be performed to confirm that the interconnection and interoperation functions of equipment and systems interconnecting *distributed energy resources* (DERs) with the *electric power system* (EPS) conform to IEEE Std 1547, as revised, corrected, or amended.

¹Information on normative references can be found in [Clause 2](#).

1.3 Purpose

Distributed energy resources (DERs) shall meet the requirements specified in IEEE Std 1547. Standardized test and evaluation procedures are necessary to establish and verify compliance with those requirements. These procedures shall provide repeatable results and flexibility to accommodate a variety of DER technologies and functions.

1.4 Limitations

This standard does not cover testing for product safety.

Although this standard does not define a certification process, these tests may be used as part of such a process.²

1.5 Compliance review

The tests and procedures in this standard are intended to provide reasonable test coverage for DER components and systems in meeting the requirements of IEEE Std 1547, but it cannot anticipate and cover all aspects of IEEE Std 1547. There are likely to be scenarios that this standard does not anticipate. The requirements of IEEE Std 1547 apply to systems operating in the field and over their operating lifetime. *Type tests* and *commissioning tests*, for example, may not be able to predict exact performance of systems in the field.

2. Normative references

The following referenced documents are indispensable for the application of this document (i.e., they must be understood and used; therefore, each referenced document is cited in text and its relationship to this document is explained). For dated references, only the edition cited applies. For undated references, the latest edition of the referenced document (including any amendments or corrigenda) applies.

DNP3 Application Note AN2018-001, DNP3 Profile for Communications with Distributed Energy Resources.

IEC 61000-3-6, Electromagnetic compatibility (EMC)—Part 3-6: Limits—Assessment of emission limits for the connection of distorting installations to MV, HV and EHV power systems.³

IEC/IEEE 62271-37-013, International Standard for High-voltage switchgear and control gear—Part 37—013: Alternating-current generator circuit-breakers.

IEEE C37.04™-2018, IEEE Standard for Ratings and Requirements for AC High-Voltage Circuit Breakers with Rated Maximum Voltage Above 1000 V.^{4, 5}

²For example, in the U.S. it is typical for inverter-based DERs to be approved under Underwriter's Laboratories Standard 1741 (UL 1741), which directly references IEEE Std 1547 and calls for application of the test procedures in IEEE Std 1547.1. In this example, *type tests* in IEEE Std 1547.1 are typically conducted by a Nationally Recognized Testing Laboratory (NRTL), and the *DER unit* is approved for compliance with UL 1741, indicating it has passed the IEEE Std 1547.1 *type tests*.

³IEC publications are available from the International Electrotechnical Commission (www.iec.ch).

⁴IEEE publications are available from The Institute of Electrical and Electronics Engineers (<http://standards.ieee.org/>).

⁵The IEEE standards or products referred to in this clause are trademarks of The Institute of Electrical and Electronics Engineers, Inc.

IEEE Std C37.09™-2018, IEEE Standard Test Procedures for AC High-Voltage Circuit Breakers with Rated Maximum Voltage Above 1000 V.

IEEE Std C37.60™, IEEE/IEC International Standard—High-voltage switchgear and controlgear—Part 111: Automatic circuit reclosers and fault interrupters for alternating current systems up to 38 kV.

IEEE Std C37.90.1™, IEEE Standard for Surge Withstand Capability (SWC) Tests for Relays and Relay Systems Associated with Electric Power Apparatus.

IEEE Std C37.90.2™, IEEE Standard for Withstand Capability of Relay Systems to Radiated Electromagnetic Interference from Transceivers.

IEEE Std C37.111™/IEC 60255-24, IEEE/IEC Measuring relays and protection equipment—Part 24: Common format for transient data exchange (COMTRADE) for power systems.

IEEE Std C62.41.2™, IEEE Recommended Practice on Characterization of Surges in Low-Voltage (1000 V and Less) AC Power Circuits.

IEEE Std C62.45™, IEEE Recommended Practice on Surge Testing for Equipment Connected to Low-Voltage (1000 V and Less) AC Power Circuits.

IEEE Std C62.92.1™, IEEE Guide for the Application of Neutral Grounding in Electrical Utility Systems—Part I: Introduction.

IEEE C62.92.6™, IEEE Guide for Application of Neutral Grounding in Electrical Utility Systems, Part VI—Systems Supplied by Current-Regulated Sources.

IEEE Std 112™, IEEE Standard Test Procedure for Polyphase Induction Motors and Generators.

IEEE Std 115™, IEEE Guide for Test Procedures for Synchronous Machines—Part I—Acceptance and Performance Testing and Part II—Test Procedures and Parameter Determination for Dynamic Analysis.

IEEE Std 421.5™, IEEE Recommended Practice for Excitation System Models for Power System Stability Studies.

IEEE Std 1159.3™, IEEE Recommended Practice for Power Quality Data Interchange Format (PQDIF).

IEEE Std 1547™, IEEE Standard for Interconnection and Interoperability of Distributed Energy Resources with Associated Electric Power Systems Interfaces.

IEEE Std 1815™-2012, IEEE Standard for Electric Power Systems Communications-Distributed Network Protocol (DNP3).

IEEE Std 2030.5™-2018, IEEE Standard for Smart Energy Profile Application Protocol.

SunSpec DER Information Model Specification, published on July 15 of 2019, available at <https://sunspec.org>.

3. Definitions, abbreviations, and acronyms

3.1 Definitions

For this document, the following terms and definitions apply. See IEEE Std 1547 for additional relevant definitions. The *IEEE Standards Dictionary Online*⁶ should be consulted for terms not defined in this subclause or in IEEE Std 1547.

Because this standard is integrally linked with IEEE Std 1547, many terms are used in both documents. Some definitions from IEEE Std 1547-2018 that are frequently used here are repeated verbatim for the convenience of readers. Those definitions are marked with an asterisk (*).

abnormal operating performance category*: The grouping for a set of requirements that specify technical capabilities and settings for a DER under abnormal operating conditions, i.e., outside the continuous operation region.

ac test source: An assembly of voltage and frequency test equipment replicating a utility power source for the purposes of DER testing. Where appropriate, the actual *area EPS* may be used as the *ac test source*.

area electric power system (area EPS)*: An EPS that serves *local EPSs*.

NOTE—Typically, an *area EPS* has primary access to public rights-of-way, priority crossing of property boundaries, etc., and is subject to regulatory oversight.⁷

area electric power system operator (area EPS operator)*: The entity responsible for designing, building, operating, and maintaining the *area EPS*.

authority governing interconnection requirements (AGIR)*: A cognizant and responsible entity that defines, codifies, communicates, administers, and enforces the policies and procedures for allowing electrical interconnection of DER to the *area EPS*. This may be a regulatory agency, public utility commission, municipality, cooperative board of directors, etc. The degree of AGIR involvement will vary in scope of application and level of enforcement across jurisdictional boundaries. This authority may be delegated by the cognizant and responsible entity to the *area EPS operator* or regional reliability coordinator (as defined in IEEE Std 1547-2018).

NOTE—Decisions made by AGIR should consider various stakeholder interests, including but not limited to load customers, *area EPS operators*, *DER operators*, and regional reliability coordinator.

clearing time*: The time between the start of the abnormal condition and the DER ceasing to energize the *area EPS*. It is the sum of the *detection time*, any adjustable time delay, the operating time plus arcing time for any interposing devices (if used), and the operating time plus arcing time for the *interrupting device* (used to interconnect the DER with the *area EPS*).

commissioning test: A test conducted when the equipment is installed to verify correct operation.

DER evaluation: *Design evaluation* or *installation evaluation*.

distributed energy resource operator (DER operator)*: The entity responsible for operating and maintaining the *distributed energy resource*.

⁶*IEEE Standards Dictionary Online* is available at <http://dictionary.ieee.org>.

⁷Notes in text, tables, and figures of a standard are given for information only and do not contain requirements needed to implement the standard.

DER unit: A fully compliant DER that does not require *supplemental DER devices* to meet the requirements of IEEE Std 1547.

DER system: A system that consists of *DER unit(s)* and *supplemental DER device(s)* that is type tested as a system and installed in accordance with the DER manufacturer’s instructions and that, as a whole, is fully compliant with IEEE Std 1547.

DER composite: A system that consists of partially compliant DER components and *supplemental DER device(s)*, and requires detailed design evaluation, *installation evaluation*, and *commissioning tests* to determine full compliance to IEEE Std 1547 requirements.

design evaluation: An evaluation (desk study) during the design and interconnection review process to verify that the fully compliant *DER system* or composite of the individual partially compliant DERs forming a system as designed meets the interconnection and interoperability requirements of IEEE Std 1547. This evaluation is usually done off-site before equipment is delivered and installed.

detection time: The minimum length of time from the inception of an abnormal condition to the change in state of the device or function dedicated to controlling the *interrupting device*. *Syn:* **processing time**.

distributed energy resource (DER)*: A source of electric power that is not directly connected to a bulk power system, as defined in IEEE Std 1547-2018. DER includes both generators and energy storage technologies capable of exporting active power to an EPS. An *interconnection system* or a *supplemental DER device* that is necessary for compliance with this standard is part of a DER.

NOTE—Controllable loads used for demand response are not included in the definition of DER.

electric power system (EPS)*: Facilities that deliver electric power to a load. *See also:* **area electric power system (area EPS); local electric power system (local EPS)**.

NOTE—This may include generation units.

installation evaluation: An evaluation at the time of DER commissioning to verify that the fully compliant *DER system* or composite of the individual partially compliant *DER units* forming a system as delivered and installed meets the interconnection and interoperability requirements of IEEE Std 1547.

intentional island*: A planned electrical *island* that is capable of being energized by one or more *local EPSs*. These (1) have DER(s) and load, (2) have the ability to disconnect from and to parallel with the *area EPS*, (3) include one or more *local EPS(s)*, and (4) are intentionally planned.

NOTE—An *intentional island* may be an intentional *area EPS island* or an intentional *local EPS island* (also: “*facility island*”).

interconnection system*: The collection of all interconnection and interoperability equipment and functions, taken as a group, used to interconnect a DER to an *area EPS*.

interrupting device: A device capable of being opened whose purpose is to disconnect loads or interrupt load current or fault current and restore service.

NOTE—These devices can be manual, automatic, or motor-operated. Examples include circuit breakers, motor-operated switches, and electronic switches.

island*: A condition in which a portion of an *area electric power system (area EPS)* is energized solely by one or more *local EPSs* through the associated PCCs while that portion of the *area EPS* is electrically separated from the rest of the *area EPS* on all phases to which the DER is connected. When an *island* exists, the DER energizing the *island* may be said to be “*islanding*.”

local electric power system (local EPS)*: An EPS contained entirely within a single premises or group of premises.

minimum required accuracy (MRA): The minimum required steady-state measurement and calculation accuracy of a DER for a given parameter, as defined in Table 3 in IEEE Std 1547-2018.

multiphase: Describes a system or device with two or more phases derived from separate transformers or a three-phase transformer. The nominal phase angle between phases is 120 degrees or 240 degrees.

NOTE—120/240V three-wire systems (i.e., split-phase systems) are not considered *multiphase* since they are derived from a single transformer from a single phase of the distribution system.

nameplate ratings*: Nominal voltage (V), current (A), maximum active power (kW), apparent power (kVA), and reactive power (kvar) at which a DER is capable of sustained operation.

NOTE—For *local EPS* with multiple *DER units*, the aggregate DER nameplate rating is equal to the sum of all DERs' nameplate rating in the *local EPS*, not including aggregate capacity limiting mechanisms such as coincidence factors, *plant controller* limits, etc., that may be applicable for specific cases.

paralleling device: A device (e.g., circuit breaker) operating under the control of a synchronizing function to electrically connect two energized power sources together.

plant controller: A control system that manages and commands other devices in the *DER system* or *DER composite*, including the *DER units* and any *supplemental DER devices*, as well as collects measurement and status information of the aggregated *DER units* and other *supplemental DER devices*. The *plant controller* may function as the DER's interoperability interface. The *plant controller* may also perform any of the IEEE 1547 control functions as designed by the *DER operator*.

NOTE—Also referred to as system controller or master controller.

point of common coupling (PCC)*: The point of connection between the *area EPS* and the *local EPS*.

point of distributed energy resources connection (point of DER connection—PoC)*: The point where a *DER unit* is electrically connected in a *local EPS* and meets the requirements of IEEE Std 1547 exclusive of any load present in the respective part of the *local EPS*.

production test: A test conducted by the manufacturer on every unit of equipment prior to shipment.

reference point of applicability (RPA)*: The location where the interconnection and interoperability performance requirements specified in IEEE Std 1547 apply.

signal injection test methods: Test methods where signals are injected into the sense terminals of the equipment under test (EUT). These methods include both primary injection test methods and secondary injection test methods.

supplemental DER device*: Any equipment that is used to obtain compliance with some or all of the interconnection requirements of this standard.

NOTE—Examples include capacitor banks, STATCOMs, harmonic filters that are not part of a *DER unit*, protection devices, *plant controllers*, etc.

testing agency: The test and verification authority responsible for performing *type tests* and overseeing production testing programs to verify conformance of the DER to the standard.

NOTE—In the U.S., the *testing agency* may be required to be a Nationally Recognized Testing Laboratory.

total rated-current distortion (TRD)*: The total root-sum-square of the current distortion components (including harmonics and inter-harmonics) created by the *DER unit* expressed as a percentage of the DER rated current capacity.

type test*: A test of one or more devices manufactured to a certain design to demonstrate, or provide information that can be used to verify, that the design meets the requirements specified in this standard.

3.2 Abbreviations and acronyms

AGIR	authority governing interconnection requirements
CSV	comma-separated value
CT	current transformer
DER	distributed energy resource
DRTS	digital real-time simulator
EMI	electromagnetic interference
EPS	electric power system
EUT	equipment under test
GFOV	ground fault overvoltage
HIL	hardware-in-the-loop
HVRT	high-voltage ride-through
I/O	input/output
IA	interface algorithm
ID	identifier
kV	kilovolt
kVA	kilovolt ampere
kvar	kilovolt ampere reactive
kW	kilowatt
LROV	load rejection overvoltage
LVRT	low-voltage ride-through
MRA	minimum required accuracy (per Table 3 of IEEE Std 1547-2018)
MVA	megavolt ampere
NRTL	Nationally Recognized Testing Laboratory
PCC	point of common coupling
p.f.	power factor
PDF	portable document format
PHIL	power hardware-in-the-loop
PoC	point of [distributed energy resource (DER)] connection
p.u.	per unit
PUT	parameter under test

OPR	owner's project requirements
<i>QF</i>	quality factor
RLC	resistance, inductance, and capacitance
rms	root mean square
ROCOF	rate of change of frequency
RPA	reference point of applicability
RVC	rapid voltage changes
THD	total harmonic distortion
TLS	transport layer security
TRD	total rated-current distortion
UI	unintentional islanding
var	volt-ampere reactive
VT	voltage transformer or transducer, synonymous with potential transformer or transducer

4. General requirements

4.1 General

Implementation of these test procedures shall be conducted in accordance with appropriate safety procedures, sequences, and precautions.

This standard identifies procedures for performing the tests and verifications to verify compliance to the interconnection and interoperability requirements stated in IEEE Std 1547. As described in Clause 11 of IEEE Std 1547-2018, the requirements are evaluated in different phases of the DER implementation as follows:

- One or more samples of the DER type shall first pass applicable *type tests* (Clause 5) and interoperability tests (Clause 6); criteria that cannot reasonably be verified through *type tests* shall be verified through other means such as *DER evaluations* and *commissioning tests*. The *type testing agency*⁸ shall report the results as described in 4.5, including any partial compliance conditions.
- Each *DER unit* or *supplemental DER device* shall pass all required *production tests* applicable to that device (Clause 7).
- The *type testing agency's* results report and manufacturer's instructions shall be used for any system *design evaluations* to determine what additional tests may be required once installed, per Clause 8. The *design evaluation* shall seek to provide that all requirements of IEEE Std 1547 that have not been met through type testing will be met by means determined appropriate in the *design evaluation* (simulations, calculations, etc.) and/or through *installation evaluations* and/or *commissioning tests*.
- *Installation evaluations* and *commissioning tests* shall be performed on-site by qualified personnel as required by the *design evaluation* results, manufacturer's instructions, and interconnection requirements, per Clause 8.
- Periodic tests and verifications shall be performed on-site by qualified personnel as mutually agreed upon by the *area EPS operator* and the *DER operator* per Clause 9.

⁸In the U.S., the type testing agency may be required to be a Nationally Recognized Testing Laboratory (NRTL), which may provide certification that the DER has passed the *type tests* in this document.

NOTE—The requirements for *design evaluations*, *installation evaluations*, and *commissioning tests* vary depending on the *reference point of applicability* (RPA) for the DER and whether the DER installation includes *supplemental DER devices* that were not part of type testing. The procedures provided in [Clause 8](#) for *design evaluations*, *installation evaluations*, and *commissioning tests*, and the content in [Clause 9](#) related to periodic tests are intentionally less prescriptive than the type and *production tests* to allow for the wide variations among DER installations and *area EPS operator* procedures.

It shall be permitted to combine multiple tests into one test upon mutual agreement between the *testing agency* and the DER manufacturer provided that the combined test fulfills all requirements of the individual tests. All requirements in this document, including those in [4.7](#), shall be met by any combined tests.

4.2 Test result accuracy

The test results shall verify that the equipment under test (EUT) meets the requirements of IEEE Std 1547 within the tolerances defined in this subclause.

Unless otherwise specified in the *type tests*, the DER performance shall be within 150% of the minimum required measurement accuracy (MRA), as specified in Table 3 of IEEE Std 1547-2018 for steady-state conditions.^{9, 10} For control functions where the DER regulates an output parameter, Y , in response to a measured input parameter, X ,¹¹ the output parameter measured by the test lab, Y_{meas} , shall meet [Equation \(1\)](#):

$$Y_{\min} \leq Y_{\text{meas}} \leq Y_{\max} \quad (1)$$

where

Y_{\min}	is $Y(X_{\text{meas}} + 1.5 \times MRA(X)) - 1.5 \times MRA(Y)$ ¹²
Y_{\max}	is $Y(X_{\text{meas}} - 1.5 \times MRA(X)) + 1.5 \times MRA(Y)$ ¹³
$Y(X)$	is a mathematical function defining the target DER output parameter (active or reactive power) in terms of the input (voltage, frequency, or active power)
X_{meas}	is the input parameter as measured by the test lab
$MRA(a)$	is the DER's minimum required steady-state measurement accuracy of a per Table 3 in IEEE Std 1547-2018, where a is an input or output parameter under test (voltage, reactive power, active power, or frequency)

An example of the application of [Equation \(1\)](#) is provided in [Annex C](#).

Other methods of verifying the DER meets the criteria for a *type test* shall be permitted if specified in the relevant *type test* subclause.

⁹DER control performance for a given parameter cannot be required to have greater accuracy than the DER can measure. Thus the DER cannot be required to control an output parameter within 100% of MRA of the expected value, where MRA is specified in Table 3 of IEEE Std 1547-2018. The “150% of MRA” criteria used in [Equation \(1\)](#) allows for both DER measurement uncertainty (MRA) and control uncertainty.

¹⁰DER should also meet the transient measurement requirements in Table 3 of IEEE Std 1547-2018, but those requirements are not used to calculate *type test* criteria.

¹¹These control functions include voltage-reactive power, voltage-active power, active power-reactive power, and frequency droop, as specified in IEEE Std 1547-2018.

¹²This equation leverages the fact that for all reasonable implementations of the functions to which this equation applies, the equation is monotone decreasing.

¹³This equation leverages the fact that for all reasonable implementations of the functions to which this equation applies, the equation is monotone decreasing.

4.3 Testing environment

The EUT manufacturer shall specify the range of environmental conditions for the EUT. Therefore, tests shall be conducted in an environment that is within the manufacturer's specified environmental operating conditions.

4.4 Product information

The setting of limits and the structure of this standard are based on the understanding that the DER installer and user are responsible for following the installation recommendations of the DER manufacturer.

The manufacturer shall supply the EUT tester with documentation necessary for the correct installation into a typical system or process in the intended environment, which may include installation instructions, user instructions, application notes, EUT manuals, and/or other documents. A functional description and a definition of specification limits for the acceptance criteria shall be provided by the manufacturer and noted in the test report.

Any external devices or equipment or special connection requirements shall be clearly stated (including rationale) in the EUT manufacturer's instructions. Special requirements can include the amount of network impedance, volt-ampere burden of the EUT, the use of shielded or special cables, maximum cable length, and the use of filters. If different devices or connection requirements apply in different environments, this shall also be stated. A list of auxiliary equipment (e.g., options or enhancements) that can be added to the EUT and that can impact the result of EUT tests shall be made available. This information shall also be documented in the test report to clarify the as-tested arrangement(s). Accuracy and tolerances of device parameters shall be stated by the EUT manufacturers.

Where the EUT is a *DER system* as defined in 3.1, the manufacturer's instructions shall include at least the following information:

- Required components of the *DER system*
- Optional components of the *DER system*
- Maximum allowable impedance or voltage rise between the PCC and the PoC(s) of individual components of the *DER system*
- Allowed electrical topologies of the *DER system* (radial, daisy-chain, etc.)
- Requirements on any transformers within the *DER system*
- *DER system* communication components, if any
- Requirements on instrumentation transducers, if any
- Requirements on use of shielded or special cables, if any

When type-testing a *DER system* and evaluating its documentation, the test agency shall consider the impacts of the following on conformance of the *DER system* to the test criteria under the range of allowable *DER system* configurations:

- Voltage rise or drop between the PCC and the PoC(s) of individual components of the *DER system*
- Reactive power losses within the *DER system*
- Communication latency within the *DER system*

4.5 Test reports

4.5.1 Overview

The test results shall be documented in a summary test report described in 4.5.3 through 4.5.6.

The *testing agency* or evaluator shall also create a detailed test report, retained by the manufacturer and *testing agency*. If the test setup or testing equipment used during testing deviates from common *testing agency* methods, the report shall include sufficient information to rerun the test and reproduce the results. Within the detailed test report, test procedures, as performed, shall be documented and engineering considerations, including test modifications and exemptions, shall be described.

4.5.2 Purpose

The new requirements contained in IEEE Std 1547-2018 significantly expand the functional capabilities and complexity of DER to reflect the greater DER impact at higher penetration levels. Also, at high DER penetration levels, the DERs may need to be designed and operated in manners similar to that of the conventional units they replace in order to maintain the existing service levels. Hence, the number of parameters and settings that must be verified in association with the expanded functionality has also increased substantially. IEEE Std 1547-2018 also includes requirements for coordination with other utility protective equipment, and that coordination requires a more detailed knowledge of the performance capabilities of the DER and the existing grid. As the levels of DER use increase, it becomes increasingly critical for *area EPS operators* and others to understand the performance capabilities and limitations of the DER and to use that information during *DER evaluations* conducted in association with interconnection studies. The large volume of data and increased criticality of such data have made it imperative that performance data be summarized to identify the capabilities that were evaluated and also be presented in a standardized format. Standardized formats for testing results summaries facilitate exchanges of information between parties, reduce potential for errors during data exchanges, allow for automated *DER evaluations*, and provide traceability of test results back to the *testing agencies*. The requirements for the reporting of testing results are contained in this subclause (4.5).

4.5.3 Results reporting

The requirements contained in 4.5 shall apply to reporting of the results collected during the following types of testing:

- Type testing of representative samples of *DER units* and *DER systems* conducted or supervised by the *testing agency*.
- Production testing of *DER units* and *DER systems* conducted at time of manufacture, where the manufacturing process and production testing is periodically inspected by a *testing agency*.
- Commissioning testing conducted at time of DER installation or at other times during the *DER evaluation* process as specified by the *area EPS operator* or relevant *authority governing interconnection requirements* (AGIR).
- *Installation evaluations* or testing conducted to verify the as-built configuration. Installation testing does not require any specific reporting. *Installation evaluations* may be recorded in any mutually agreeable format that meets the requirements of [Clause 8](#).
- Periodic testing results do not require reporting in a standardized format and may be recorded in any mutually agreeable format that meets the requirements of [Clause 9](#).

The *testing agency* shall produce a summary report summarizing the results of the type testing that shall be retained by the EUT manufacturer. The *type test* summary report shall include the EUT nameplate information described in Table 28 of IEEE Std 1547-2018 and shall identify all evaluated functions,

including any associated ranges of adjustment within the range of allowable settings,¹⁴ used to demonstrate compliance with [Clause 4](#) and [Clause 5](#) of this standard. The summary of the type testing results shall be presented in the file formats defined in [4.5.3](#) through [4.5.6](#).

Production testing results shall be provided by the manufacturer upon request. The file shall include model and serial numbers of the EUTs plus any additional information, recorded at time of manufacture, using the production testing process approved and monitored by an applicable *testing agency*.

Where commissioning testing is conducted, a test report summarizing the results of commissioning testing and any recommended corrective actions shall be documented and provided to the *area EPS operator*. The scope of the testing and reporting shall be in accordance with the requirements of [Clause 8](#) or as mutually agreed between the *area EPS operator* and the *DER system* owner or operator. The commissioning summary test report shall be issued by an individual or entity qualified to perform or supervise such tests or field evaluations. The *commissioning test* summary report shall be provided in a secured portable document format (PDF) file or any other format mutually agreeable between the *area EPS operator* and the *DER system* owner or operator.

Where the *DER evaluation* or commissioning process requires settings to be applied, the report documenting the applied settings may be issued by the installer, manufacturer, or other qualified entities. The verification of applied settings report shall be provided in a secured PDF or comma-separated value (CSV) file, or any other format, mutually agreeable between the *area EPS operator* and the *DER system* owner or operator. The data structure and naming convention requirements as outlined in [4.5.5](#) shall be used in summary reports of settings as applied in the field.

4.5.4 Data formats

Testing results summaries shall be reported using both a secured PDF file for written results and a CSV file, including a 256-bit Secure Hash Algorithm (SHA-256 hash) checksum value, for tabular results. The PDF summary file shall be issued by the *testing agency*, or other applicable testing body, and shall include reference to the associated tabular CSV format filename(s), SHA-256 hash checksum value(s). A template of the tabular CSV file is referenced in [Annex B](#). The PDF summary file shall also include reference to any other files needed to demonstrate compliance with this standard, such as oscillographic data recorded in accordance with the requirements of subclause 11.4.2 of IEEE Std 1547-2018. The reference to other files shall include the file name and the checksum associated with each file.

Where oscillographic data is required to document results of testing, the data shall be supplied in either COMTRADE (IEEE Std C37.111) or PQDIF (IEEE Std 1159.3) format, and shall meet the requirements for sampling rate, accuracy and any pre- or post-event capturing specified for each test.

4.5.5 Naming convention and data structure

The naming conventions used to identify specific nameplate data in the CSV file shall utilize the Data Structure and Naming Convention shown in [4.5.5.1](#) and [4.5.5.2](#) and in the template referenced in [Annex B](#). These Naming Convention and Data Structure formats shall be used for each record in the CSV file.

4.5.5.1 Naming convention

The naming convention is as follows:

Parameter Name-Data Context-Data Type-Optional Modifier(s), Value, Units, <CR><LF>

¹⁴Where not prohibited by IEEE Std 1547-2018, settings beyond the ranges of allowable settings may also be tested, for example to demonstrate additional capability.

Parameter names are composed of the parameter base identifier, optional context qualifiers, optional type qualifiers, and additional optional modifiers. Parameter names can be composed of uppercase alpha characters, numbers, underscores, and hyphen. Underscores are used for readability within single concept portions of the name. Hyphens are used to separate data context, data type, and modifier sections of the name.

Parameter values can be one or more numbers or text strings. If a parameter value contains more than one element, the elements are separated by hyphens. Hyphens should not be used in parameter value text strings.

4.5.5.2 Data structure

Data structure is as follows:

- **Parameter Name:** as specified in Table 28 of IEEE Std 1547-2018 or naming template in [Annex B](#)
 - **Data Context:**
 - TR¹⁵ – Technical Range – May be used by EUT manufacturer to indicate the technical capabilities of the *DER unit* which may be beyond the evaluated ranges, or
 - ER – Evaluated Range – Indicates performance evaluated by the testing entity, or
 - SR – Specified Range – May be used by *area EPS operator* to indicate specified range different from the ranges of allowable settings of IEEE Std 1547-2018.¹⁶
 - SS – Specified Settings – May be used to indicate the settings specified by the *area EPS operator* or AGIR, or
 - AS – Applied Setting – Indicates the setting applied in the DER. Typically reported at time of commissioning, or following subsequent parameter changes; or
 - Other – Undefined, but allowed for future use.
 - **Data Type:**
 - MIN – Minimum value in a range of adjustment or evaluated range, or
 - MAX – Maximum value in a range of adjustment or evaluated range, or
 - **Optional Modifier(s):** Undefined, but allowed for future use.
 - **Value:**
 - The value of the parameter resulting from the type testing, or
 - The text string associated with the parameter.
 - **Units:**
 - The abbreviation for the scientific unit associated with the value, as shown in [Table 1](#).
- NOTE—Where multiple values or strings are supported, separate with underscores.
- **<CR><LF>:** Carriage return and line feed. End of record identifier.

¹⁵The Data Source designators TR, SS, SR, and Other are out of scope of IEEE Std 1547.1 but are included here to illustrate ways in which the template might be used for standardized information exchange of data commonly used in interconnection processes.

¹⁶Ranges different from the ranges of allowable settings of IEEE Std 1547-2018 should not be specified unless exceptional cases require so. These cases should be reported to the sponsor of this standard for consideration in future revisions of IEEE Std 1547-2018.

Table 1—Abbreviations of unit values

Abbreviation	Value	Abbreviation	Value
V, V p.u.	Volt (dc), V p.u. (ac)	kVA	Apparent power
A	Amps (ac or dc)	P p.u.	Per unit active power
Hz	Frequency	var p.u.	Per unit reactive power
s	Time in seconds	PF	Power factor (injecting or absorbing)
Text	Text string	S	Reactive susceptance (formerly Mho)
Ohms	Resistance (R) or Reactance (X)		
Per unit values are based on the corresponding nameplate values of the EUT			

NOTE—The requirements in this clause are scope constrained to the reporting of results occurring during type testing of *DER units*. During the development of this standard, numerous other stakeholders have expressed interest in creating a standardized format for exchange of DER parameters for other purposes. Some examples of possible uses would be as follows: specification of utility requirements documents, local modifications of source requirements, modeling of DER performance for distribution as well as transmission planning and protection, etc. While such use is out of scope of this standard, the data structure and Naming Conventions specified previously allow for such uses via the Data Source and Optional Modifiers fields. Data Source identifiers might identify a specific utility or regional authority. The optional modifiers identifier might identify sub requirement based on location, time of use, multiple tariff requirements, etc. While these uses are out-of-scope, the standard acknowledges the value of standardized data exchange formats and provides flexibility in data structure/naming conventions to support those uses.

4.5.6 Traceability

The Type Testing Summary Report shall identify the name and address of the *testing agency*. The report shall include references to any certificates of compliance or report numbers associated with *DER evaluation*. The report shall include the issuance date of the report and the name of the individual responsible for issuance of the report.

4.6 Testing equipment requirements

4.6.1 AC test source requirements

Where testing allows or requires the use of an *ac test source*, the following requirements shall be met unless stated otherwise in a specific test procedure:

- The *ac test source* shall be capable of confirming the EUT manufacturer’s stated performance.
- The voltage harmonics of the *ac test source*, as measured with the EUT connected and operating in steady state at rated power, shall be less than 3.0% total harmonic distortion (THD).
- During the tests, the steady-state *ac test source* voltage shall not vary by more than $\pm 1\%$ of nominal (0.01 p.u. on the nominal voltage base) from the set voltage.
- During the tests, the steady-state *ac test source* frequency shall not vary by more than 0.1 Hz unless required by the test.
- The *ac test source* used for each test shall have sufficient resolution of voltage and frequency control to produce the test profiles designated in the respective tests.
- The *ac test source* used for each test shall be capable of changing voltage and frequency at a rate that is sufficient to meet the requirements of the respective tests.¹⁷
- The *ac test source* used for each test shall be capable of producing the voltage or frequency profile required by that test. The *testing agency* shall confirm through evaluation of the voltage and

¹⁷See annexes and *type tests* for additional information on test voltage and frequency profiles.

frequency profile measured at the EUT's voltage sense points that the applied voltage and frequency meet the requirements of the test.

- The number of phase and neutral connections provided by the *ac test source* shall be compatible with the EUT. A *multiphase ac test source* that provides a neutral connection shall produce phase-to-neutral voltages that are balanced within $\pm 3\%$ of nominal and phase displacement to within $\pm 3^\circ$. For *multiphase ac test sources* without a neutral connection, the phase-to-phase voltage balance shall be $\pm 3\%$ of nominal in magnitude. For three-phase *ac test sources*, the negative sequence voltage of the *ac test source* shall be less than 1.5%.
- The *ac test source* may include a load bank, for example to sink power when a source that cannot sink power is used, unless otherwise specified in a test.

Where *signal injection test methods* are used, the injected voltage signal shall meet the requirements of this subclause, scaled to the level of the injected signal. The test report shall state which tests used signal injection and briefly state the rational justification for its use.

For the purposes of production and *commissioning tests*, it might not be feasible to meet all of the above requirements on the *ac test source*. In the case of *production tests*, the manufacturer and *testing agency* shall establish acceptable requirements. In the case of *commissioning tests*, the *area EPS operator* and the *DER operator* or their designated representatives shall establish acceptable requirements.

For tests and EUTs that are within the scope of IEEE Std 4, in the case of any conflicting requirements, those of IEEE Std 1547.1 shall apply.

4.6.2 Simulated DER input source requirements

If the *testing agency* and the DER manufacturer agree that the following two conditions are true, it shall be permitted to use substitute hardware to emulate the prime mover or DER input energy source:

- The emulation system adequately captures the dynamics of the real prime mover or input energy source for all time scales relevant to the test for which it is to be used.¹⁸
- Vulnerabilities including DER auxiliary systems that may affect the DER's ability to perform the test are properly captured. Auxiliary systems (for example, control power supplies, pumps, etc.) may be of particular concern in ride-through tests.

4.6.3 Measurement system requirements

Test system measurements shall have an uncertainty of no more than 0.5 times the minimum required DER measurement accuracy for steady-state measurements in Table 3 of IEEE Std 1547-2018.

The required frequency measurement uncertainty may be achieved by post-processing sampled waveform data.¹⁹

Measurement equipment shall be capable of confirming the DER meets the test criteria for each test.

Measurement equipment used to confirm performance of an EUT shall have valid (non-expired) and traceable calibration.²⁰

¹⁸This statement is not intended to require that photovoltaic inverters be tested with real PV arrays or solar array simulators or that battery inverters be tested with real batteries or dynamic battery emulators; a dc voltage source may be sufficient. Input source requirements may depend on the specific test being performed.

¹⁹At the time of drafting of the standard, typical measurement equipment often did not meet the frequency measurement uncertainty requirement. While it is preferable that measurement equipment (or its specifications) be updated to meet the uncertainty requirement, post-processing of sampled data is allowed to avoid creating a requirement that cannot be met by typical equipment.

The sampling rate of the measurement system used for each test shall be at least two times the frequency of the measured signal (including any harmonics and transients of interest for the test). Filtering shall not limit the ability of the measurement system to accurately capture the measured signal.

For tests and EUTs that are within the scope of IEEE Std 4, in the case of any conflicting requirements, those of IEEE Std 1547.1 shall apply.

Where not specified otherwise in this standard, applicable voltages shall be quantified as the effective (rms) values over the preceding fundamental frequency period, per IEEE Std 1547.

4.7 Requirements on *type test* order and selection of DER sample(s)

During type testing, certain groups of tests shown in Table 2 shall be run using the same EUT sample and with certain restriction on test order as defined in the following list and in Table 2. The intent of this requirement is to evaluate any impacts of one test on another test in the same group.

- Tests listed within a single cell of Table 2 may be run in any order, but shall be run before tests in the cell immediately to the right, if any.
- Tests not listed in Table 2 may be run in any order, on any sample.

Running all *type tests* on a single sample while accounting for the test order requirements in Table 2 is one way to meet this requirement.

Table 2—Test groups to be run on a single sample

Group	Subgroup 1	Subgroup 2
1	5.3 Temperature stability ^a 5.8 Interconnection integrity ^a	5.4.2 Test for overvoltage trip 5.4.3 Test for undervoltage trip 5.5.1 Test for overfrequency trip 5.5.2 Test for underfrequency trip
2	5.4.4 Low-voltage ride-through tests 5.4.7 High-voltage ride-through tests 5.5.3 Test for low-frequency ride-through 5.5.4 Test for high-frequency ride-through 5.5.5 Test for rate of change of frequency (ROCOF)	5.10 Unintentional islanding

^a Temperature stability and interconnection integrity tests may be run on different EUT samples provided that at least 30% of voltage trip tests and at least 30% of frequency trip tests are run on each sample.²¹

All samples used in type testing shall have identical hardware, software, and firmware. The *testing agency* shall record and report all EUT serial numbers; hardware model numbers; control board assembly versions; software version numbers; firmware version numbers; and other identifiers that distinguish hardware, software, and firmware for the tested samples. Aside from serial numbers, all other distinguishing identifiers shall be verified as identical by the *testing agency*.

In the case of a test failure resulting in a modification to the DER, the test agency shall decide whether to re-run some or all previous tests based on the nature of the modification. This may apply to tests in the same group within Table 2, tests in a different group, and/or tests not listed in Table 2.

²⁰For example, in the U.S. and some other locations, ISO 17025 is used to provide guidance on calibration criteria.

²¹The intent of this requirement is to require that a significant portion of trip tests are run on a sample that has undergone temperature stability testing and a significant portion are run on a sample that has undergone interconnection integrity testing without requiring that a single sample undergo both interconnection integrity and temperature testing. A sample used for temperature testing may be modified to insert temperature sensors, which could compromise its ability to withstand interconnection integrity tests in some cases.

4.8 Intentional island-capable DERs and devices

For DERs and devices designed to be capable of operating in an *intentional island*, the tests shall cover the extended ranges specified by the manufacturer for *intentional island* operation. The values of any extended ranges shall comply with 8.2.7 of IEEE Std 1547-2018. The manufacturer shall specify which of the DER categories listed in 8.2.8 of IEEE Std 1547-2018 for *intentional islands* the device or DER falls into; the device or DER may fall into more than one *intentional island* category. The test report shall state the ranges of settings tested.

During transition to and from *intentional island* operation, the *area EPS* island shall comply with 8.2.4 through 8.2.6 of IEEE Std 1547-2018.

5. Type tests

5.1 General

Type tests are performed or overseen by a *testing agency* on one or more representative unit(s) and may be conducted in the factory, at a testing laboratory, or on equipment in the field. Equipment under test shall be installed per the manufacturer's specification and operated under the conditions specified for each test (or nominal operating conditions if not specified).

As stated in IEEE Std 1547-2018, *type test* results from a DER within a product family of the same design, including hardware and software (with electrical components proportionally scaled according to the DER voltage and current ratings), shall be allowed as representative of other DERs within the same product family with power ratings between 50% to 200% of the tested DER.

Exception: Each member of a product family shall be tested according to 5.17 and 5.18 unless the DER manufacturer and the testing agency mutually agree that one member of the family is representative of the entire family for the purposes of maximum sustained fault current, in which case the tests in 5.17 and 5.18 may be performed on only one representative member of the family.

Where it is not feasible for technical reasons to evaluate the EUT using one or more of the test regimens specified in this standard, alternative test regimens agreed to by the manufacturer and the *testing agency* and accomplishing the same measurements with the same accuracy may be used. When used, the details of such alternative test regimens shall be recorded in the test report along with an explanation of why the alternative test regimen was used.

Signal injection test methods may be used only when it is explicitly stated that they are allowed in a given subclause. Injected voltage signals shall meet the requirements of 4.6.1, scaled appropriately.

Several test procedures require the EUT to be operated at different discrete power levels (e.g., 33%, 66%, and 100% of rated power). Adjustments may be made to the EUT to achieve the discrete power levels, provided that these adjustments do not otherwise affect the performance of the EUT for the parameter under test (PUT), unless otherwise specified. Alternatively, to accomplish testing at discrete power levels, the input source may be power limited to result in the desired EUT output power levels unless otherwise specified.

IEEE Std 1547 allows for type testing to be performed on complete systems, multifunction relays, discrete devices, or any combination. If type testing is performed on anything other than a fully integrated system, some of the component times in Figure A.1 may not be available. In these cases, production and/or *commissioning tests* shall be conducted to fully demonstrate the ability of the complete system to comply with the timing required by IEEE Std 1547. As an alternative, the test report may show that the sum of

individual component timings meets the requirement; in such cases, the individual component timings shall be documented in the report as well. Other requirements also apply when type testing is performed on an EUT that is not a fully integrated system, as described in Clause 11 of IEEE Std1547-2018 and in [Clause 8](#) of this standard.

When the EUT manufacturer requires a transformer installed between the EUT and RPA, several *type tests* require that the transformer be included during testing as part of the equipment under test. When the EUT manufacturer instructions allow more than one transformer configuration, the relevant tests shall be repeated with each configuration. In such cases, the transformer used in type testing may have any convenient turns ratio. The impedance (resistance and reactance) and winding configuration(s) of the transformer used for type testing shall be as listed in the EUT manufacturer's specifications.

5.2 Priority of responses

The tests needed to demonstrate compliance with the requirements of 4.7 (Priority of Responses) in IEEE Std 1547-2018 were duly considered and are included in, and are part of, the tests in [5.4](#), [5.5](#), [5.10](#), [5.13](#), and [5.16](#) of this standard.

5.3 Temperature stability

5.3.1 Purpose

This test verifies that the EUT maintains measurement accuracy of parameters as required in Table 3 of IEEE Std 1547-2018 over its specified operating temperature range. Because of the wide variation in DER equipment, it is not possible to specify a single test procedure that works for all DERs. Therefore, a functional test procedure to verify the EUT's measurement accuracy shall be agreed to by the manufacturer and the *testing agency*. The functional test procedure shall confirm EUT operation within the minimum required measurement accuracy for magnitude and time.

5.3.2 General

Where protective, monitoring, measurement, and control functions can be conveniently separated from the remainder of the DER without impacting the function of the EUT, the remainder of the DER may be omitted from this test.²² However, the manufacturer shall provide the *testing agency* with substantive information to verify that the complete DER performs acceptably over the manufacturer's stated operating temperature range. If only a portion of the DER is tested, the maximum and minimum temperature tests shall be run at the temperature that portion would experience when the DER is operating at the maximum and minimum operating temperatures, respectively.

The measurement accuracy verifications may be conducted with the EUT operating at any convenient power level.

²²This does not remove the requirement that the measurement accuracy of voltage, frequency, active power, and reactive power be verified at maximum and minimum operating temperatures.

5.3.3 Procedures

5.3.3.1 Operational temperature test procedure

The test shall seek to verify that the equipment has reached the desired temperature by allowing the equipment to stabilize at the specified chamber temperature. Stabilized temperature is reached after a minimum of 2.5 h and when three successive temperature readings taken at 30 minute intervals are at or above maximum temperature for high temperature tests, or at or below minimum temperature for low temperature tests. For the minimum operating temperature point, the equipment shall remain deenergized until the stable temperature has been achieved in the test chamber. The test procedure is as follows:

- a) Select test temperatures per the EUT specification. The EUT shall be tested at the minimum and maximum operating temperatures.
- b) The measurement parameters to be validated over the temperature range include voltage, active power, reactive power, and frequency. In addition, a *clearing time* test shall be conducted at the high end of the temperature range, and an Enter Service test shall be conducted at the low end of the operating temperature range to verify that measurement accuracy of time is acceptable.
- c) Perform the tests and record the data.
- d) At each temperature point selected in step a), repeat each test selected in step b) for a total of five times.

5.3.4 Criteria

The trip and Enter Service functions shall operate properly over the operating temperature range as specified by the manufacturer.

The following shall be true at the maximum and minimum temperature of the EUT's specified operating temperature range:

The steady-state measured values of voltage, frequency, active power, and reactive power as reported by the DER shall be equal to the respective externally measured values plus or minus the MRA for each parameter.

5.3.5 Comments

It may not be necessary or feasible to execute temperature tests using the complete EUT. Per the DER manufacturer's recommendation, just the components that measure and control the parameters under test need to be tested over the specified temperature range. Signal injection testing may be performed with these components per the manufacturer's recommendation. Primary signal injection shall be used, or the worst-case uncertainty of the sensor(s) shall be factored into the test criteria.

The EUT should be arranged in the environmental chamber in such a manner that reduces, if not eliminates, opening of the chamber during testing. If the chamber must be left partially open, steps should be taken to facilitate reaching and maintaining the required temperatures. This is especially important at cold temperatures where opening of the chamber door may cause instant condensation that may affect the test. If the chamber door must be opened during test, allow sufficient time for the temperature to return to the desired test value.

The EUT enclosure should be included in high temperature testing to account for the additional temperature rise due to the enclosure. If including the enclosure is not practical, then the ambient temperature shall be increased to a level that is representative of the EUT's internal operating temperature at maximum ambient operating temperature.

Conversely, the use of the enclosure can prevent the equipment from reaching its minimum operating temperature due to the internal rise. To account for this, the equipment should not be energized until the desired low temperature is attained or the temperature is lowered to account for the additional rise. If the manufacturer specifies a cold temperature start-up procedure, that procedure should be followed.

It is recommended that the cold temperature testing be completed first since cooling a heated chamber requires a much longer time than heating a cool chamber.

Care should be taken to mitigate condensation and frosting when performing tests after the cold soak period.

5.4 Test for response to voltage disturbances

5.4.1 General

If the EUT provides means to remotely sense voltages, the manufacturer's supplied instructions shall identify the signal injection ports on the EUT. If the remote voltage sensing function is a part of a *DER system*, the manufacturer's supplied instructions shall identify the signal injection ports on any equipment required for the remote voltage sensing function.

Where remote voltage sensing functionality is provided, the manufacturer's instructions shall specify the maximum allowable total resistance and reactance of any conductors, switchgear, or transformers between the remote sensing point and the EUT terminals.

Where remote voltage sensing functionality is provided as an option for a *DER unit*, the tests in 5.4.2 and 5.4.3 shall be tested with voltages applied at the EUT terminals and again with the specified impedance inserted between the EUT and the remote sensing point. For remote sensing tests, the voltages shall be applied at the identified remote voltage sensing terminals.

Where remote voltage sensing functionality is part of a *DER system*, the tests in 5.4.2 and 5.4.3 shall be tested with voltages applied at the EUT terminals and again with the specified maximum resistance and reactance impedances inserted between the EUT and the remote sensing point. The voltages shall be applied on the identified terminals of any other required voltage sensing equipment. The tests in 5.4.4 and 5.4.7 are not required to be repeated provided that any optional remote sensing equipment is included during the ride through testing.

EUTs may be tested at any convenient power level and power factor unless otherwise specified in the test procedure.

Signal injection test methods may be used only where indicated in the test procedure.

5.4.2 Test for overvoltage trip

5.4.2.1 Purpose

The purpose of this test is to verify that the EUT ceases to energize the *area EPS* and trips within the *clearing time* specified in IEEE Std 1547 with respect to overvoltage conditions. This test determines the magnitude and *clearing time* for each overvoltage tripping function.

5.4.2.2 Procedure

This procedure uses the step function defined in A.3. For these tests, voltage is substituted for the variable P as indicated in the procedures defined in Annex A.

- a) Connect the EUT according to the instructions and specifications provided by the manufacturer.
- b) Set all source parameters to the nominal operating conditions for the EUT.
- c) Set (or verify) all EUT parameters to the nominal operating settings. If the overvoltage setting is adjustable, set the EUT to the minimum overvoltage setting, but no less than the nominal voltage plus twice the *minimum required accuracy* for voltage.
- d) Set the trip time setting to the minimum.
- e) Record applicable settings.

For single-phase units, adjust the applicable voltage to parameter starting point P_b , as defined in A.3, to a value greater than or equal to the setpoint value determined in step c) minus 200% of the MRA.²³ The source shall be held at this voltage for a period t_h .²⁴

At the end of this period, initiate a step of the voltage to a level less than or equal to the setpoint value plus 200% of the MRA using the procedure specified in A.3. For *multiphase* units, adjust voltage on one phase using the values above. Verify that remaining phases are held at nominal ± 0.02 p.u.

- f) Record all voltage magnitudes when the unit trips.
- g) Repeat steps e) through f) four times for a total of five tests.
- h) For *multiphase* units, repeat steps e) through g) for the applicable voltage on each phase or phase pair individually, and all phases simultaneously.
- i) If the trip magnitude is adjustable, repeat steps e) through h) at the maximum of the range.
- j) Set the trip time setting to the maximum and repeat steps e) through i).
- k) Repeat steps c) through k) for each overvoltage operating trip region.

5.4.2.3 Requirements

The *ac test source* shall meet the requirements of 4.6.1. The measurement system shall meet the requirements of 4.6.3. Signal injection methods are permitted to be used. Where signal injection methods are used, the manufacturer shall identify the EUT's signal injection points.

²³The minimum required accuracy (MRA) as defined as specified in Table 3 of IEEE Std 1547-2018 for steady-state conditions.

²⁴The variable t_h is at 100% of the trip time setting plus 200% the minimum required measurement accuracy (MRA), as specified in Table 3 of IEEE Std 1547-2018 for steady-state conditions.

5.4.2.4 Criteria

The EUT shall be considered in compliance if it ceases to energize the *ac test source* and trips within respective *clearing times* for each overvoltage range specified in IEEE Std 1547. The evaluated ranges of adjustment for tripping magnitude and duration shall be greater than or equal to the allowable ranges of adjustment for each overvoltage tripping range specified in IEEE Std 1547.

5.4.3 Test for undervoltage trip

5.4.3.1 Purpose

The purpose of this test is to verify that the EUT ceases to energize the *area EPS* and trips within the *clearing time* specified in IEEE Std 1547-2018 with respect to undervoltage conditions. This test determines the magnitude and *clearing time* for each undervoltage tripping function.

5.4.3.2 Procedure

This procedure uses the step function defined in A.3. For these tests, voltage is substituted for the variable *P* as indicated in the procedures defined in Annex A.

- a) Connect the EUT according to the instructions and specifications provided by the manufacturer.
- b) Set all source parameters to the nominal operating conditions for the EUT.
- c) Set (or verify) all EUT parameters to the nominal operating settings. If the undervoltage setting is adjustable, set the EUT to the maximum undervoltage setting but no greater than the nominal voltage minus twice the *minimum required accuracy* for voltage.
- d) Set the trip time setting to the minimum.
- e) Record applicable settings.

For single-phase units, adjust the applicable voltage to parameter starting point Pb, as defined in A.3, to a value less than or equal to the setpoint value determined in step c) plus 200% of the MRA.²⁵ The source shall be held at this voltage for a period t_h .²⁶

At the end of this period, initiate a step of the voltage to a level greater than or equal to the setpoint value minus 200% of the MRA using the procedure specified in A.3. For *multiphase* units, adjust voltage on one phase using the values above. Verify that remaining phases are held at nominal ± 0.02 p.u.

- f) Record all voltage magnitudes when the unit trips.
- g) Repeat steps e) through f) four times for a total of five tests.
- h) For *multiphase* units, repeat steps d) through g) for the applicable voltage on each phase or phase pair individually, and on all phases simultaneously.
- i) If the trip magnitude is adjustable, repeat steps e) through h) at minimum of the range.
- j) Set the trip time setting to the maximum and repeat steps e) through i).
- k) Repeat steps c) through j) for each undervoltage operating trip region.

²⁵The minimum required accuracy (MRA) as defined as specified in Table 3 of IEEE Std 1547-2018 for steady-state conditions.

²⁶The variable t_h is at 100% of the trip time setting plus 200% the minimum required measurement accuracy (MRA), as specified in Table 3 of IEEE Std 1547-2018 for steady-state conditions. This number may be adjusted to avoid conflict with other trip points.

5.4.3.3 Requirements

If used, the *ac test source* shall meet the requirements of 4.6.1. The measurement system shall meet the requirements of 4.6.3. Signal injection methods are permitted to be used. Where signal injection methods are used, the manufacturer shall identify the EUT's signal injection points.

5.4.3.4 Criteria

The EUT shall be considered in compliance if it ceases to energize the *ac test source* and trips within the respective *clearing times* for each undervoltage tripping range specified in IEEE Std 1547. The evaluated ranges of adjustment for tripping magnitude and duration shall be greater than or equal to the allowable ranges of adjustment for each undervoltage tripping range specified in IEEE Std 1547.

5.4.4 Low-voltage ride-through tests

5.4.4.1 Purpose

The low-voltage ride-through (LVRT) test verifies the ability of the EUT to ride through voltage sags without tripping in accordance with the requirements in 6.4.2 of IEEE Std 1547-2018.

5.4.4.2 Test procedure

During the LVRT test, the settings for magnitude and duration of undervoltage tripping functions shall be disabled or set so as not to influence the outcome of the test. The voltage-reactive power control mode of the EUT shall be set to the default settings specified in Table 8 of IEEE Std 1547-2018 for the applicable performance category, and enabled. If the EUT provides a voltage-active power control mode, that mode shall be disabled. The frequency-active power control mode of the EUT shall be set to the default settings.

The ride-through tests shall be performed at two output power levels, high and low, and at any convenient power factor greater than 0.90. The output power levels shall be measured prior to the disturbance, i.e., in test condition A. High-power tests shall be performed at any active power level greater than 90% of the EUT nameplate active power rating at nominal voltage. Where the EUT active power is limited by the prime mover, the high-power test shall be performed at any power level greater than 90% of the active power rating at the power factor specified above, or at any power level greater than 90% of the nameplate active power rating, whichever is greater. Low-power tests shall be performed at any convenient power level between 25% to 50% of EUT nameplate apparent power rating at nominal voltage. The DER modes of operation under abnormal conditions (*Momentary Cessation*, *Cease to Energize*,²⁷ *Mandatory Operation* or *Permissive Operation*²⁸) shall be evaluated using the tests in 5.4.4.3.

The test signals in Figure 1, Figure 2, and Figure 3 illustrate the voltage sags that shall be applied on the EUT terminals in accordance with the test condition voltage profiles shown in Table 3, Table 4, and Table 5 for each applicable *abnormal operating performance category* of the EUT.²⁹ Alternatively, two or

²⁷Cease to Energize is the cessation of current exchange of DER with Area EPS in not more than the maximum specified time and with no intentional delay. Cease to Energize does not necessarily imply disconnection, isolation, or a trip of the DER. Cease to Energize may include momentary cessation or trip. See IEEE Std 1547 for the complete definition of Cease to Energize and related terms.

²⁸Where the mode of operation is specified as Permissive Operation the DER may continue to output current or may enter Momentary Cessation. See IEEE Std 1547 for the complete definition of Permissive Operation and related terms.

²⁹The intent of the voltage profiles in the tables and figures is to demonstrate that the EUT can meet the IEEE Std 1547 ride-through requirements slightly outside the lowest voltage specified for each region in IEEE Std 1547. Relatively wide voltage ranges are provided for each test condition to allow flexibility in performing the test. It is not the intent of the tests to require the EUT to be capable of riding through to the lowest voltage specified in each range.

more test conditions may be substituted by a single test provided that the substitute test condition uses the lowest voltage magnitude of any combined test condition for a duration greater than or equal to the sum of the individual durations of any combined individual test conditions. Where the specified operating mode in any test case of the combined test is mandatory operation the EUT shall operate in the mandatory operating mode only. *Exception:* If the combined test includes both *Momentary Cessation* and *Mandatory Operation*, then the EUT shall operate in *Momentary Cessation* mode.

The voltage level of the *ac test source* in each test condition shall be induced sequentially with no interruption between test conditions. Where there is a step change in voltage level required between one test condition and the next, the *ac test source* shall produce the voltage transition in no more than 2 cycles. Positively damped voltage oscillations subsequent to the initial transition to the target value are permitted.

The voltage used for determining the magnitude and duration of the voltage excursion for each undervoltage operating performance region shall be calculated using the average of the rms voltage during each excursion period. For three-phase EUTs, each voltage sag profile shall be repeated by changing voltage on all three phases simultaneously—at least one two-phase pair simultaneously, and at least one single phase individually. Where phase-to-neutral or phase-to-ground voltages are applicable voltages as defined in Table 1 and Table 2 of IEEE Std 1547-2018, the testing shall be repeated with the applicable voltages for each configuration supported by the EUT. For line-to-line connected single-phase EUTs, the voltage sag profile sequence shall be applied line-to-line. For line-to-neutral connected single-phase EUTs, the voltage sag profile shall be applied line-to-neutral. For EUTs that are approved only for use in ungrounded three-wire low-voltage services or for use in delta medium-voltage connections, phase-to-neutral tests may be omitted.

Where auxiliary loads are powered by, or control power is derived from, a single phase-to-neutral or phase-to-phase connection, the manufacturer shall identify the phases used for control power or auxiliary loads. The two-phase and single-phase voltage sag profile sequences shall be applied on any phases that provide control power and any phases providing power to any auxiliary loads.

Table 3 defines the LVRT test conditions for DER Category I. The resulting LVRT test signal is depicted in Figure 1.

NOTE—For test conditions B, C, C' and D in Table 3, the durations are cumulative from time t_1 including any residual voltage that is less than or equal to the residual voltage in any preceding test condition in the sequence. The duration of test condition E is independent and not cumulative from any preceding test condition in the sequence.

For Table 3 test condition D, the minimum required ride-through performance is described by a linear slope of voltage and duration as described in Equation (2).

$$\text{For } t_3 < t \leq t_4: V = 0.7 \text{ p.u.} + [(1 \text{ p.u.}) \times (t - t_3)] / (4 \text{ s}) \quad (2)$$

The test voltage linear slope may be approximated using a stepwise increase consisting of one or more test voltage steps. The voltage magnitude and duration of each test voltage step shall be selected such that the sum of the products of the duration of each step multiplied by the voltage magnitude of the respective test voltage is less than the average magnitude of the specified linear slope multiplied by the duration of the specified linear slope.

Table 4 defines the LVRT test conditions for DER Category II. The resulting LVRT test signal is depicted in Figure 2.

NOTE—For test conditions B, C, D, D' and E in Table 4 the durations are cumulative from time t_1 including any residual voltage that is less than or equal to the residual voltage in any preceding test condition in the sequence. The duration of test condition F is independent and not cumulative from any preceding test condition in the sequence.

For Table 4 test condition E, the minimum required ride-through performance is described by a linear slope of voltage and duration as described in Equation (3).

$$\text{For } t_4 < t \leq t_5: V = 0.65 \text{ p.u.} + [(1 \text{ p.u.}) \times (t - t_4)] / (8.7 \text{ s}) \quad (3)$$

The test voltage linear slope may be approximated using a stepwise increase consisting of one or more test voltage steps. The voltage magnitude and duration of each test voltage step shall be selected such that the sum of the product of the duration of each step multiplied by the voltage magnitude of each test voltage step is less than the average magnitude of each specified linear slope multiplied by the duration of each specified linear slope.

Table 5 defines the LVRT test conditions for DER Category III. The resulting LVRT test signal is depicted in Figure 3.

NOTE—For Test Conditions B, C, C' and D in Table 5 the durations are cumulative from time t_1 including any residual voltage that is less than or equal to the residual voltage in any preceding test condition in the sequence. The duration of test condition E is independent and not cumulative from any preceding test condition in the sequence.

Table 3—Category I LVRT test conditions

Test condition	Residual voltage (p.u.)	Minimum duration ^a (s)	Time interval in Figure 1	Required DER mode of operation ^b
A	0.88–1.00	20	t_0-t_1	Continuous Operation
B	0.00–0.50	0.16	t_1-t_2	Permissive Operation ^c
C	0.50–0.70	0.70	t_1-t_3	Mandatory Operation ^c
C'	0.72–0.88	2.12	t_1-t_3	Mandatory Operation ^d
D	0.70–0.88	1.42	t_1-t_4	Mandatory Operation
E	0.88–1.00	120	t_4-t_5	Continuous Operation

^a The minimum duration times are cumulative including all prior test conditions in the sequence at the same or lower magnitude.

^b During each test condition specified in column 1, the EUT is required to operate in the mode shown in column 5.

^c If during test condition B the EUT ceases to energize, then the EUT may remain in cease to energize mode for voltages less than 0.70 p.u.

^d If the EUT ceases to energize during test condition B, test condition C' shall be used to evaluate restore output performance per 6.4.2.7 of IEEE Std 1547-2018 if this cannot be determined by test condition D. The residual voltage shall be high enough that any voltage oscillations remain above 0.72 p.u.

^e This test intentionally violates the cease to energize operating mode specified in IEEE Std 1547 to verify the EUT's ability to ride through with trip settings adjusted so as not to cause tripping during the test. The cease to energize and trip behavior is tested separately in 5.4.3.

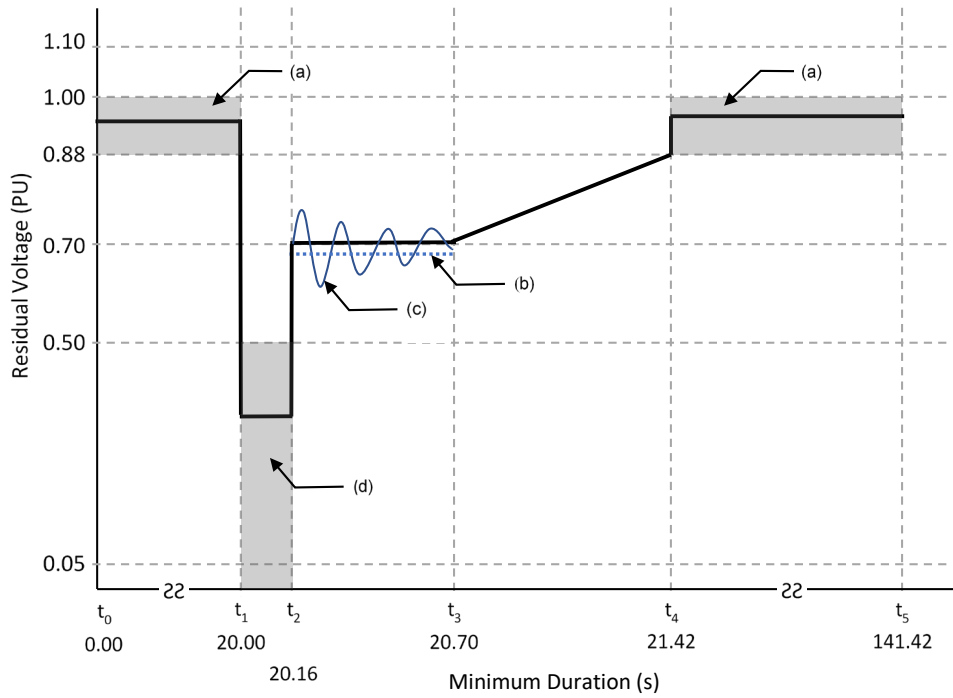

NOTES—

- (a) Any voltage between 1.00 p.u. and 0.88 p.u. is permitted.
- (b) Average of the rms voltage over duration of excursion.
- (c) Example of positively damped voltage oscillations allowed during testing.
- (d) Any voltage less than 0.50 p.u. is permitted.

Figure 1—Category I LVRT test signal

Table 4—Category II LVRT test conditions

Test condition	Residual voltage (p.u.)	Minimum duration ^a (s)	From-To time	Required DER mode of operation ^b
A	0.88–1.00	10	t_0-t_1	Continuous Operation
B	0.00–0.30	0.160	t_1-t_2	Permissive Operation ^c
C	0.00–0.45	0.320	t_1-t_3	Permissive Operation
D	0.45–0.65	3	t_1-t_4	Mandatory Operation ^c
D'	0.67–0.88	8	t_1-t_4	Mandatory Operation ^d
E	0.65–0.88	5	t_1-t_5	Mandatory Operation
F	0.88–1.00	120	t_5-t_6	Continuous Operation

^a The minimum duration times are cumulative including all prior test conditions in the sequence at the same or lower magnitude.

^b During each test condition specified in column 1 the EUT is required to operate in the mode shown in column 5.

^c If during test condition C the EUT ceases to energize, then the EUT may remain in cease to energize mode for voltages less than 0.65 p.u.

^d If the EUT ceases to energize during test condition C, test condition D' shall be used to evaluate restore output performance per 6.4.2.7 of IEEE Std 1547-2018 if this cannot be determined by test condition D. The residual voltage shall be high enough that any voltage oscillations remain above 0.67 p.u.

^e This test intentionally violates the cease to energize operating mode specified in IEEE Std 1547 to verify the EUT's ability to ride through with trip settings adjusted so as not to cause tripping during the test. The cease to energize and trip behavior is tested separately in 5.4.3.

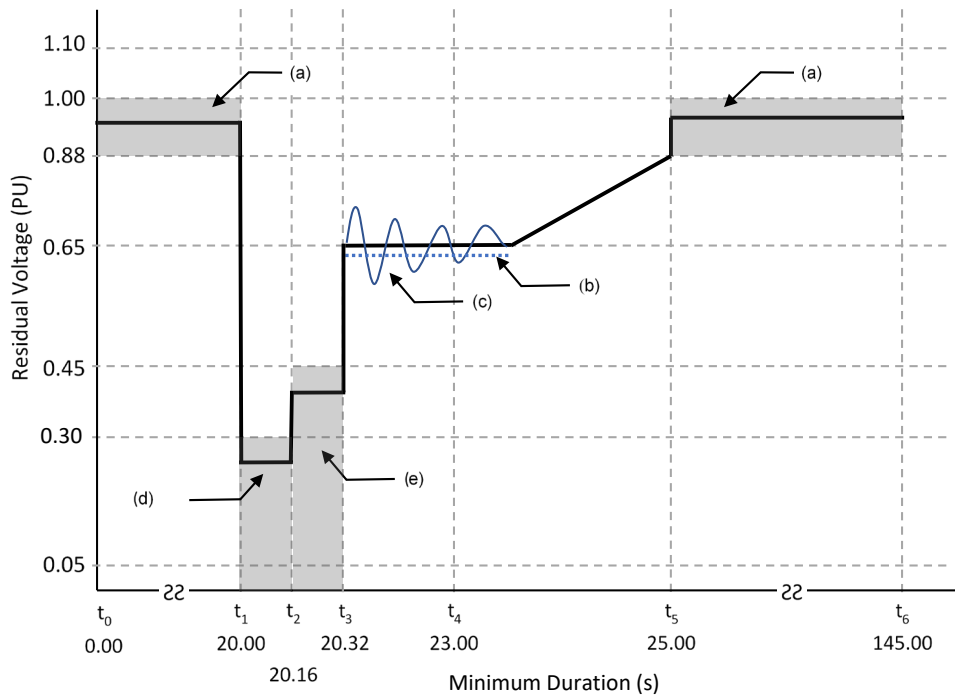

NOTES—

- (a) Any voltage between 1.00 p.u. and 0.88 p.u. is permitted.
- (b) Average of the rms voltage over duration of excursion.
- (c) Example of positively damped voltage oscillations allowed during testing.
- (d) Any voltage less than 0.30 p.u. is permitted.
- (e) Any voltage less than 0.45 p.u. is permitted.

Figure 2—Category II LVRT test signal

Table 5—Category III LVRT test conditions

Test condition	Residual voltage (p.u.)	Minimum duration ^a (s)	From-To time	Required DER mode of operation ^b
A	0.88–1.00	5	t_0-t_1	Continuous Operation
B	0.00–0.05	1	t_1-t_2	Momentary Cessation
C	0.00–0.50	10	t_1-t_3	Mandatory Operation ^c
C'	0.52–0.70	10	t_1-t_3	Mandatory Operation ^d
D	0.50–0.70	20	t_1-t_4	Mandatory Operation
E	0.88–1.00	120	t_4-t_5	Continuous Operation

^a The minimum duration times are cumulative including all prior test conditions in the sequence at the same or lower magnitude.

^b During each test condition specified in column 1 the EUT is required to operate in the mode shown in column 5.

^c During this test condition, the EUT may stay in momentary cessation for voltages less than 0.50 p.u. but shall not trip.

^d This test condition shall be used to evaluate restore output performance per 6.4.2.7 of IEEE Std 1547-2018 if this cannot be determined by test condition C. The residual voltage shall be high enough that any voltage oscillations remain above 0.52 p.u.

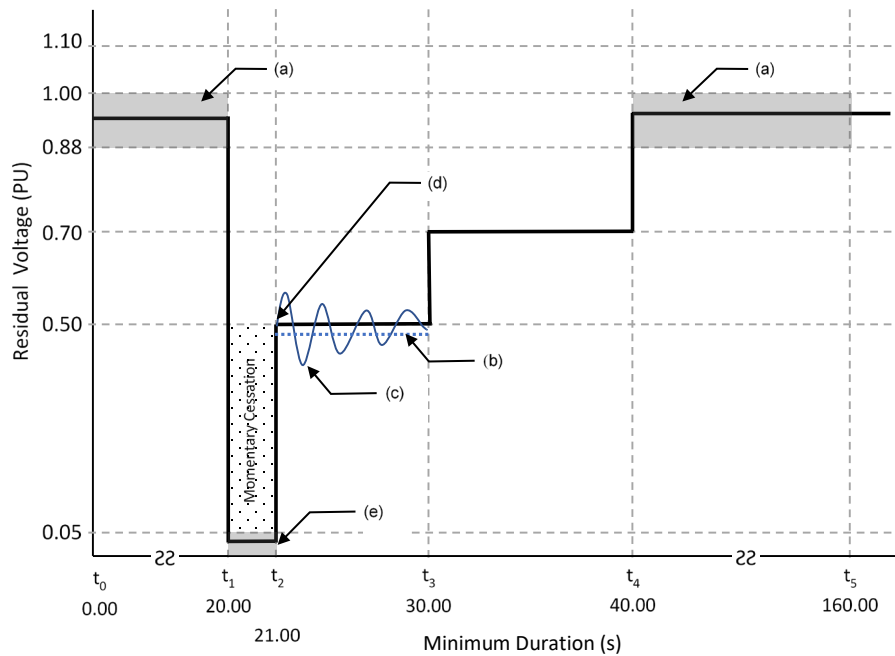

NOTES—

- (a) Any voltage between 1.00 p.u. and 0.88 p.u. is permitted.
- (b) Average of the rms voltage over duration of excursion.
- (c) Example of positively damped voltage oscillations allowed during testing.
- (d) DER shall restore output within 0.400 seconds following momentary cessation, i.e., following time t_2 .
- (e) Any voltage less than 0.05 p.u. is permitted.

Figure 3—Category III LVRT test signal

5.4.4.3 Consecutive ride-through test

The low-voltage ride-through test sequences shall be repeated without interruption in accordance with the requirements in 6.4.2.5 of IEEE Std 1547-2018. The test sequence for each category shall be as shown in the following untitled table.

Category	Sequence of test conditions in Table 3 to Table 5	Notes
I	A, B, C, D, A, B, C, D, E A, B, C', E ^a	Test Condition E may be conducted at 0.88 ± 0.02 p.u. or at any voltage between 0.88 p.u. and 1.00 p.u.
II	A, B, C, D, E A, B, C, D, E, F A, B, C, D', F ^a	Test Condition F may be conducted at 0.88 ± 0.02 p.u. or at any voltage between 0.88 p.u. or 1.00 p.u.
III	A, B, C, D, A, B, C, D, A, B, C, D, E A, B, C', D, E ^b	Test Condition E may be conducted at 0.88 ± 0.02 p.u. or at any voltage between 0.88 p.u. and 1.00 p.u.

^aThis test sequence is only conducted if the EUT ceases to energize during the permissive operation region or if the restore output capability cannot be evaluated in the other test sequences.

^bThis test sequence is only conducted if the restore output capability cannot be evaluated in the other test sequences.

When the final test condition in each sequence is conducted at 0.88 ± 0.02 p.u. the results may be used to demonstrate compliance with the continuous operation at the low-voltage requirements of 5.1 of IEEE Std 1547-2018. Alternatively, the final test condition may be conducted at any voltage between 0.88 p.u. and 1.00 p.u. and a separate test shall be conducted with the EUT operating at 0.88 ± 0.02 p.u. for not less than 120 s to demonstrate compliance with the continuous operation at the low-voltage requirements of 5.1 of IEEE Std 1547-2018.

The consecutive ride-through tests shall be performed at the same power levels as those specified for the individual ride through tests as applicable for the respective abnormal performance operating categories specified for the EUT.

5.4.4.4 Requirements

The *ac test source* (either variable voltage *ac test source* or alternate fixed voltage *ac test source* with short-circuit simulator from Annex G)³⁰ shall not be required to comply with the requirements of 4.6.1. The *ac test source* shall meet the following requirements:

- Where test signal residual voltages are specified as a minimum voltage, the average of the rms voltage during the test interval shall be maintained at or below the specified minimum value.
- Where test signal residual voltages are specified as a range of voltages, the average of the rms voltage during the test interval shall be maintained within the specified voltage range.

The EUT for this test is the entire DER, including the prime mover or prime energy source, if feasible. Where it is infeasible to test with the actual energy source, a synthetic representation of that source may be substituted. The characteristics of this source shall be specified by the EUT manufacturer. The testing shall identify any vulnerabilities of the prime mover or prime energy source to ride through conditions.

The measurement system shall comply with the requirements of 4.6.3.

³⁰Additional guidance on test equipment selection and setup may be found in Annex G and in IEC TS 62910.

5.4.4.5 Criteria

The EUT shall be considered in compliance if it meets all of the following requirements:

- Where the operating mode is specified as *Mandatory Operation*, the EUT shall not trip, shall maintain synchronism and maintain its total apparent current during the disturbance period at or above 80% of the pre-disturbance value.
- Where the operating mode is specified as *Permissive Operation*, the EUT may *Cease to Energize* followed by *Restore Output*, or may continue to exchange current with the *ac test source*. The EUT shall ride through and shall not trip during *Permissive Operation*. Where the EUT rides through in a *Cease to Energize* state, the EUT shall comply with the *Restore Output* requirements in 6.4.2.7 of IEEE Std 1547-2018.
- Where the operating mode is specified as *Momentary Cessation*, the EUT shall cease to energize the *ac test source*. Following the momentary cessation event, the EUT shall comply with the *Restore Output* requirements of 6.4.2.7 of IEEE Std 1547-2018.

Active and reactive current oscillations that are positively damped are permitted during the disturbance and post-disturbance periods.

5.4.5 Test for voltage disturbances within continuous operating region

5.4.5.1 Purpose

The purpose of this test is to verify that *multiphase* DERs continue to operate, as specified in 6.4.2.2 of IEEE Std 1547-2018, during voltage disturbances where the applicable voltage remains within the continuous operating region as defined by IEEE Std 1547. The test is intended to verify compliance with the unbalanced voltage operating conditions required in IEEE Std 1547.

5.4.5.2 Procedure

The unbalanced condition test shall be carried out as stated below. For DER not capable of operation isolated from external source, a variable voltage *ac test source* or a fixed voltage *ac test source* with short circuit simulator³¹ is required for the test. For DER capable of operation isolated from external source, the *ac test source* may be replaced by a load bank with unbalanced loading. During the unbalanced voltage test, the settings for magnitude and duration of under voltage tripping functions shall be set so as not to influence the outcome of the test. The EUT shall be operated at rated active power with unity power factor at nominal voltage and frequency at the occurrence of the unbalanced voltage disturbance. With the EUT connected to the *ac test source* as per manufacturer's recommendations, the *ac test source* shall create the unbalanced voltage conditions specified in [Table 6](#) with applicable voltage remaining within continuous operating region.

³¹See [Annex G](#) for short circuit simulator requirements.

Table 6—DER unbalanced voltage test conditions

Test condition	Negative sequence voltage (p.u.)	Duration (s)
A	≥ 0.1	≥ 60
B	≥ 0.05	≥ 300

5.4.5.3 Criteria

The DER shall be considered in compliance if it remains in operation during disturbances in [Table 6](#) and continues to deliver available active power of magnitude at least as great as its pre-disturbance level of active power, prorated by the per-unit voltage level of the least phase voltage if that voltage is less than the nominal voltage. Temporary deviations of active power that have durations not exceeding 0.5 s shall be allowed.

5.4.6 Test for dynamic voltage support

No requirements for this function are defined in IEEE Std 1547.

NOTE—Where the manufacturer optionally elects to demonstrate capability for dynamic voltage support, the manufacturer should describe the behavior of the function and then use any testing profile mutually agreeable between the manufacturer and the *testing agency*. The results of the testing should validate the manufacturer's stated behavior for the function.

5.4.7 High-voltage ride-through tests

5.4.7.1 Purpose

The high-voltage ride-through (HVRT) verifies the ability of the EUT to ride through voltage swells without tripping in accordance with the requirements in 6.4.2 of IEEE Std 1547-2018. For EUTs complying with abnormal performance Category I and II, the required mode of operation is *Permissive Operation*. In abnormal performance Category III, the required mode of operation is *Momentary Cessation*. EUTs may be approved for multiple abnormal performance categories. During the HVRT test the settings for magnitude and duration of overvoltage tripping functions shall be disabled or set so as not to influence the outcome of the test. The frequency-active power control mode of the EUT shall be set to the default settings. If the EUT provides a voltage-active power control mode, that mode shall be disabled. Compliance with HVRT requirements may be verified using one of the following two methods:

- Where the EUT is capable of independent operation, the capability to operate for sustained periods at high voltage may be demonstrated by operating into a resistive load bank at an active power level greater than 90% of nameplate active power rating, in accordance with the testing requirements in [5.4.7.2](#). If this method is used, the performance of any active or reactive power control functions such as voltage-active power, voltage-reactive power, or momentary cessation shall be tested separately. Signal injection methods may be used to verify correct control system operation in accordance with the applicable testing requirements in this subclause.
- The EUT may be operated in parallel with an *ac test source* at high- and low-power levels in accordance with the applicable testing requirements in [5.4.7.3](#).

5.4.7.2 Test procedure using a resistive load

As an alternative to the methods described in 5.4.7.3 and 5.4.7.4, the EUT may be evaluated using the test apparatus shown in 5.4.7.5. During these tests switch S2 shall remain open or the *ac test source* may be otherwise disconnected.

The EUT shall be operated at any active power level greater than or equal to 90% of its nameplate active power rating. The EUT output voltage shall be adjusted to provide an rms voltage greater than or equal to 1.20 p.u., and at least this voltage level shall be maintained for a period of not less than 2 seconds for Categories I and II, or not less than 36 seconds for Category III. Immediately following operation at a voltage not less than 1.2 p.u., the EUT shall be operated at an rms voltage of not less than 1.1 p.u. for a total duration of not less than 600 seconds. EUT output voltages and currents, measured at the terminals of the EUT, shall be collected and used to confirm compliance with the HVRT requirements.

5.4.7.3 Test procedure using a programmable ac test source

The voltage-reactive power control mode of the EUT shall be set to the default settings specified in Table 8 of IEEE Std 1547-2018 for the applicable performance category, and enabled.

For EUTs that have demonstrated compliance with the HVRT requirements using the resistive load tests in 5.4.7.2, the correct operation of the control system may be verified using signal injection methods using the tests in this clause. Where signal injection methods are used the manufacturer shall identify the location of the input ports of the control system where the applicable voltage test signals shall be applied. The manufacturer shall identify the location of control system outputs, including any external devices needed to implement the functionality, e.g., a relay or contactor. Alternatively, correct operation of the control system may be verified by operating the EUT in parallel with an *ac test source* at any convenient power level greater than 25% of EUT nameplate apparent power rating.

For all other EUTs, the ride-through tests shall be performed at two output power levels, high and low, and at any convenient power factor greater than 0.90. High-power tests shall be performed at active power level greater than 90% of the EUT nameplate active power rating at nominal voltage. Where the EUT active power is limited by the prime mover, the high-power test shall be performed at any power level greater than 90% of the active power rating at the specified power factor or the 90% of the nameplate active power rating, whichever is greater. Low-power tests shall be performed at any convenient power level between 25% to 50% of EUT nameplate apparent power rating at nominal voltage.

Where the DER mode of operation in any test case is specified as *Cease to Energize*³² or *Momentary Cessation*, the behavior of the EUT in these operating regions shall be evaluated using the tests in 5.4.7.4.

Where the DER operating mode is specified as *Mandatory Operation* or *Permissive Operation* the behavior of the EUT shall be evaluated using the tests in this subclause. Where the mode of operation is specified as *Permissive Operation*, the DER may continue to output current or may enter *Momentary Cessation*.

The test signals in Figure 4 and Figure 5 illustrate the voltage swells that shall be applied on the EUT terminals in accordance with the test case voltage profiles shown in Table 7 and Table 8 for each applicable *abnormal operating performance* category of the EUT. Alternatively, two or more test cases may be combined into a single test provided that the combined test condition uses the highest voltage magnitude and longest duration of any of the individual test cases.

The voltage levels in each test condition shall be induced sequentially with no interruption between test conditions. Where there is a step change in voltage level required between one test condition and the next,

³²Cease to Energize is the cessation of current exchange of DER with Area EPS in not more than the maximum specified time and with no intentional delay. Cease to Energize does not necessarily imply disconnection, isolation, or a trip of the DER. Cease to Energize may include momentary cessation or trip.

the *ac test source* shall produce the voltage transition in no more than 2 cycles. Positively damped voltage oscillations subsequent to the initial transition to the target value are permitted.

The voltage used for determining the magnitude and duration of the voltage excursion for each overvoltage operating performance region shall be calculated using the average of the rms voltage during each excursion period.

For three phase EUTs, each voltage swell profile shall be repeated by changing voltage on all three phases simultaneously, at least one two-phase pair simultaneously, and at least one single phase individually. The voltage swell profile sequences shall be conducted using phase-to-phase voltage excursions and repeated using phase-to-neutral voltage excursions. For EUTs that are approved only for use in ungrounded three-wire low-voltage services or for use in delta medium-voltage connections, phase-to-neutral tests may be omitted.

For line-to-line connected single-phase EUTs, the voltage swell profile sequence shall be applied line-to-line. For line-to-neutral connected single-phase EUTs, the voltage swell profile shall be applied line-to-neutral.

Where auxiliary loads are powered by, or control power is derived from, a single phase-to-neutral or phase-to-phase connection, the manufacturer shall identify the phases used for control power or auxiliary loads. The two-phase and single-phase voltage swell profile sequences shall be applied on any phases that provide control power and any phases providing power to any auxiliary loads.

Table 7 defines the HVRT test conditions for DER Category I and II. The resulting HVRT test signal is depicted in Figure 4.

Table 7—Category I and II HVRT test conditions

Test condition	Residual voltage (p.u.)	Minimum duration ^a (s)	Time interval in Figure 4	Mode of operation
A	1.00–1.10	10 ^b	t_0-t_1	Continuous Operation
B	1.18–1.20	0.2	t_1-t_2	Permissive Operation
C	1.155–1.175	0.5	t_1-t_3	Permissive Operation
D	1.13–1.15	1.0	t_1-t_4	Permissive Operation
E	1.00–1.10	120	t_4-t_6	Continuous Operation

^a The minimum duration times are cumulative including all prior test conditions in the sequence at the same or greater magnitude.
^b For Category I equipment, the minimum duration may be 20 seconds in accordance with IEEE Std 1547-2018 Table 17.

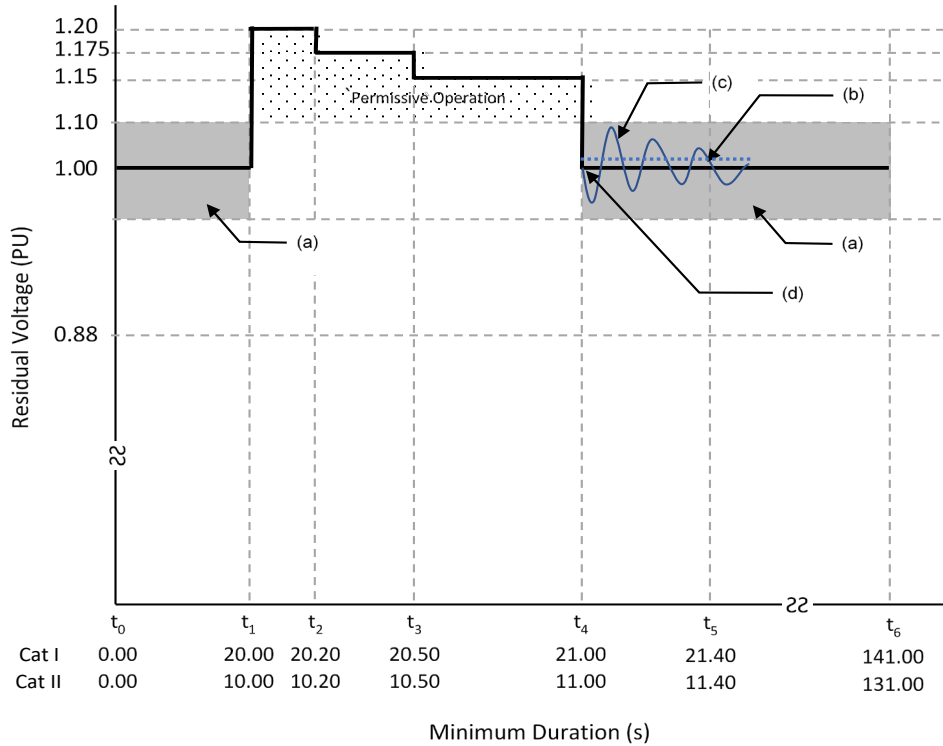

NOTE 1—Testing at any voltage between 1.10 p.u. and 1.0 p.u. is permitted.
 NOTE 2—Average of single cycle rms voltage over duration of excursion.
 NOTE 3—Example of positively damped voltage oscillations allowed during testing.
 NOTE 4—DER shall restore output within 0.400 seconds following momentary cessation, i.e., following time t_4 .

Figure 4—Category I and II HVRT test signal

Table 8 defines the HVRT test conditions for DER Category III. The resulting HVRT test signal is depicted in Figure 5. These test conditions are applied only during the testing in 5.4.7.4.

Table 8—Category III HVRT test conditions

Test condition	Residual voltage (p.u.)	Minimum duration ^a (s)	From-To time	Mode of operation
A	1.00–1.10	5	t_0 – t_1	Continuous Operation
B	1.18–1.20	12	t_1 – t_2	Momentary Cessation
B'	1.12–1.20	12	t_1 – t_2	Momentary Cessation ^b
C	1.00–1.10	120	t_2 – t_3	Continuous Operation

^a The minimum duration times are cumulative including all prior test conditions in the sequence at the same or greater magnitude.

^b This test condition shall be used to evaluate momentary cessation performance per IEEE Std 1547-2018 Table 16 if this cannot be determined by test condition B. The residual voltage shall be high enough that any voltage oscillations remain above 1.12 p.u.

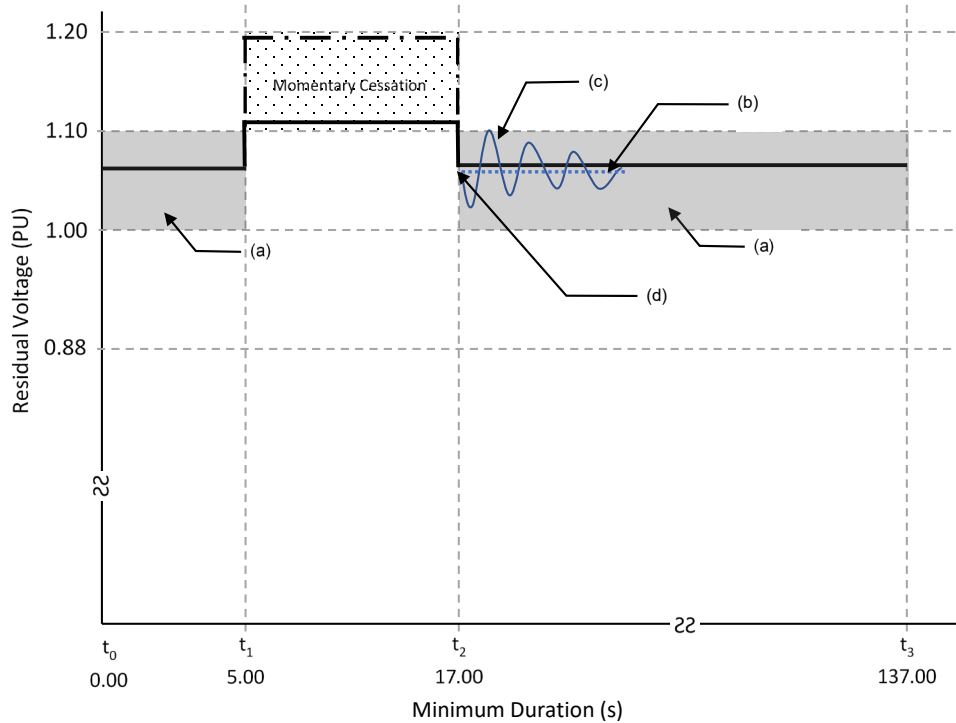

- NOTE 1—Testing at any voltage between 1.00 p.u. and 1.10 p.u. is permitted.
- NOTE 2—Average of single cycle rms voltage over duration of excursion.
- NOTE 3—Example of positively damped voltage oscillations allowed during testing.
- NOTE 4—DER shall restore output within 0.400 seconds following momentary cessation, i.e., following time t_2 .

Figure 5 —Category III HVRT test signal

5.4.7.4 Consecutive ride-through test

The high-voltage ride-through test sequences shall be repeated without interruption in accordance with the requirements in 6.4.2.5 of IEEE Std 1547-2018. The test sequence for each category shall be as shown in the following untitled table.

Category	Sequence of test conditions in Table 7 and Table 8	Notes
I	A, B, C, D, A, B, C, D, E	Test condition E may be conducted at 1.10 ± 0.02 p.u. or at any voltage between 1.00 p.u. or 1.10 p.u.
II	A, B, C, D, A, B, C, D, E	Test condition E may be conducted at 1.10 ± 0.02 p.u. or at any voltage between 1.00 p.u. or 1.10 p.u.
III	A, B, A, B, A, B, C A, B', C ^a	Test condition C may be conducted at 1.10 ± 0.02 p.u. or at any voltage between 1.00 p.u. or 1.10 p.u.

^a This test sequence is only conducted if the EUT momentary cessation performance cannot be evaluated in the other test sequences.

When the final test condition in each sequence is conducted at 1.10 ± 0.02 p.u. the results may be used to demonstrate compliance with the continuous operation at the high-voltage requirements of 5.1 of IEEE Std 1547-2018. Alternatively, the final test condition may be conducted at any voltage between 1.00 p.u. and 1.10 p.u. and a separate test shall be conducted with the EUT operating at 1.10 ± 0.02 p.u. for not less than 120 s to demonstrate compliance with the continuous operation at the high-voltage requirements of 5.1 of IEEE Std 1547-2018.

5.4.7.5 Requirements

The HVRT test procedure shall use the test setup in Figure 6.

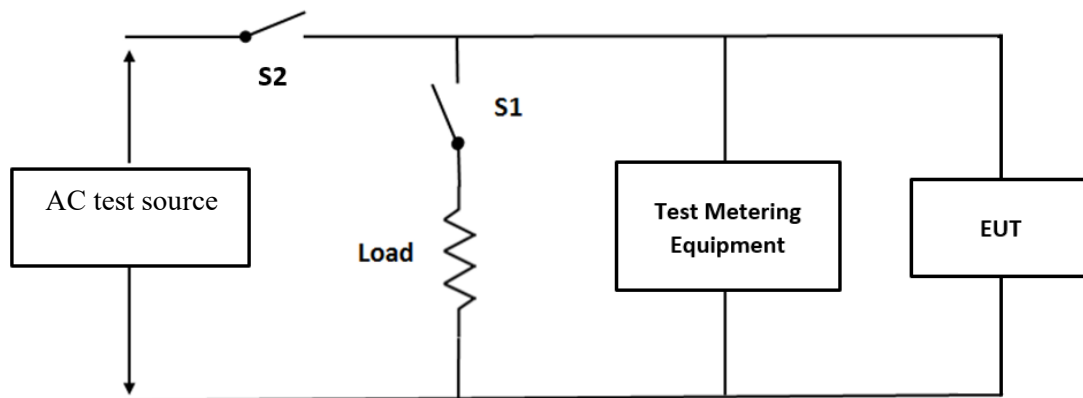

Figure 6—HVRT test apparatus

Where the voltage ride-through capability is verified using a resistive load bank without an *ac test source* per 5.4.7.2, the load bank shall be capable of absorbing the full output power of the EUT during the test. For the procedure in 5.4.7.3, the resistive load bank and switch S1 are optional and not required for *ac test sources* capable of absorbing the output of the EUT.

The *ac test source*³³ shall not be required to comply with the requirements of 4.6.1. The *ac test source* shall meet the following requirements:

- Where test signal residual voltages are specified as a minimum voltage, the average of the rms voltage during the test interval shall be maintained at or below the specified minimum value.
- Where test signal residual voltages are specified as a range of voltages, the average of the rms voltage during the test interval shall be maintained within the specified voltage range.

The EUT for this test is the entire DER, including the prime mover or prime energy source, if feasible. Where it is infeasible to test with the actual energy source, a synthetic representation of that source may be substituted. The characteristics of this source shall be specified by the EUT manufacturer. The testing shall identify any vulnerabilities of the prime mover or prime energy source to ride through conditions.

³³Additional guidance on test equipment selection and setup may be found in Annex G and in IEC 62910.

5.4.7.6 Criteria

The EUT shall be considered in compliance if it meets all the following requirements:

Where the operating mode is specified as *Permissive Operation*, the EUT may *Cease to Energize* or may continue to exchange current with the *ac test source*. The EUT shall ride through and shall not trip during *Permissive Operation*. If the operating mode of the EUT during *Permissive Operation* is *Cease to Energize*, the EUT shall comply with the *Restore Output* requirements 6.4.2.7 of IEEE Std 1547-2018.

Where the operating mode is specified as *Momentary Cessation*, the EUT shall cease to exchange current with the resistive load bank or *ac test source*. Following the momentary cessation event the EUT shall comply with the *Restore Output* requirements of 6.4.2.7 of IEEE Std 1547-2018.

Active and reactive current oscillations that are positively damped are permitted during the disturbance and post-disturbance period.

5.4.7.7 Comments

The stiffness of the *ac test source* relative to the DER rating is an important factor in the ability of the source to maintain a steady voltage during a voltage swell disturbance.

5.5 Test for response to frequency disturbances

5.5.1 Test for overfrequency trip

5.5.1.1 Purpose

The purpose of this test is to verify that the *DER unit* or system ceases to energize the *area EPS* and trips within the *clearing time* specified in IEEE Std 1547 with respect to overfrequency conditions. This test determines the magnitudes and *clearing times* for each overfrequency tripping function.

5.5.1.2 Procedure

This procedure uses the rate limited step function defined in subclause [A.4](#) of [Annex A](#). The parameter *P* becomes frequency for this test.

- a) Connect the EUT according to the instructions and specifications provided by the manufacturer.
- b) Set all *ac test source* or signal injection generator parameters to the nominal operating conditions for the EUT.
- c) Disable or program the relevant settings for all other active and reactive power control functions of the EUT to not influence the test results for the operating region being evaluated. Set the frequency droop function to the widest deadband setting and maximum droop setting to make the active power change with respect to frequency as small as possible.
- d) Set (or verify) EUT parameters to the minimum overfrequency trip magnitude setting within the range of adjustment specified by the manufacturer.
- e) Set (or verify) the EUT parameters to the minimum overfrequency trip duration setting within the range of adjustment specified by the manufacturer.

- f) Record applicable settings of the ac power source or signal injection generator and the EUT.
- g) Adjust the *ac test source* frequency from P_N to P_B . The *ac test source* shall be held at this frequency for period t_h .
- h) At the end of this period, increase the frequency to P_U and hold for a period not less than 1.5 times the *clearing time* setting.
- i) Record the frequency at which the unit trips and the *clearing time*.
- j) Repeat steps d) through i) four times for a total of five tests.
- k) Set (or verify) EUT parameters at the maximum of the overfrequency trip magnitude setting within the range of adjustment specified by the manufacturer and repeat steps e) through j).
- l) Set (or verify) the EUT parameters to the maximum overfrequency trip duration setting within the range of adjustment specified by the manufacturer and repeat steps f) through k).
- m) Repeat steps c) through l) for each overfrequency operating region.

5.5.1.3 Requirements

The programmable ac power source or signal injection generator shall meet the requirements of 4.6.1. The measurement system shall meet the requirements of 4.6.3. Signal injection methods are permitted. Where signal injection methods are used the EUT manufacturer shall identify the location of the signal injection points. During all frequency transitions, the rate of change of frequency shall be less than the ROCOF limit in Table 21 of IEEE Std 1547-2018 or, if above the ROCOF limit, shall be within the demonstrated ROCOF capability of the EUT.

5.5.1.4 Criteria

The EUT shall be considered in compliance if it ceases to energize the *ac test source* and trips within the respective *clearing times* for each overfrequency tripping range specified in IEEE Std 1547. The evaluated ranges of adjustment for tripping magnitude and duration shall be greater than or equal to the allowable ranges of adjustment for each overfrequency tripping range specified in IEEE Std 1547.

NOTE—Tripping within the “may ride through” or “may trip” regions shown in H.3 of IEEE Std 1547-2018 is allowed.

5.5.1.5 Comments

During the overfrequency trip tests the EUT shall be operated at any power level between 25% and 100% of the EUT nameplate rating. The power levels used during testing shall be high enough so to clearly differentiate the EUT’s cease to energize response from the response to the frequency-active power function.

5.5.2 Test for underfrequency trip

5.5.2.1 Purpose

The purpose of this test is to verify that the *DER unit* or system ceases to energize the *area EPS* and trips within the *clearing time* specified in IEEE Std 1547 with respect to underfrequency conditions. This test determines the magnitudes and *clearing times* for each underfrequency tripping function.

5.5.2.2 Procedure

This procedure uses the rate limited step function in A.4 defined in Annex A. The parameter “P” becomes frequency for this test.

- a) Connect the EUT according to the instructions and specifications provided by the manufacturer.
- b) Set all programmable ac power source or signal injection generator parameters to the nominal operating conditions for the EUT.
- c) Disable or program the relevant settings for all other active and reactive power control functions of the EUT to not influence the test results for the operating region being evaluated. Set the frequency droop function to the widest deadband setting and maximum droop setting to make the active power change with respect to frequency as small as possible.
- d) Set (or verify) EUT parameters to the minimum underfrequency trip magnitude setting within the range of adjustment specified by the manufacturer.
- e) Set (or verify) EUT parameters to the minimum underfrequency trip duration setting within the range of adjustment specified by the manufacturer.
- f) Record applicable settings of the *ac test source* or signal injection generator and the EUT.
- g) Adjust the source frequency from P_N to P_B . The source shall be held at this frequency for period t_h .³⁴
- h) At the end of this period, decrease the frequency to P_U and hold for a duration not less than 1.5 times the *clearing time* setting.
- i) Record the frequency at which the unit trips and the *clearing time*.
- j) Repeat steps d) through h) four times for a total of five tests.
- k) Set (or verify) EUT parameters at the maximum of the underfrequency trip magnitude setting within the range of adjustment specified by the manufacturer and repeat steps e) through j).
- l) Set (or verify) the EUT parameters to the maximum underfrequency trip duration setting within the range of adjustment specified by the manufacturer and repeat steps e) through k).
- m) Repeat steps c) through l) for each underfrequency operating region.

5.5.2.3 Requirements

The programmable ac power source or signal injection generator shall meet the requirements of 4.6.1. The measurement system shall meet the requirements of 4.6.3. Signal injection methods are permitted. Where signal injection methods are used, the EUT manufacturer shall identify the location of the signal injection points. During all frequency transitions, the ROCOF shall be less than the ROCOF limit in Table 21 of IEEE Std 1547-2018 or, if above the ROCOF limit, shall be within the demonstrated ROCOF capability of the EUT.

5.5.2.4 Criteria

The EUT shall be considered in compliance if it ceases to energize the *ac test source* and trips within the respective *clearing times* for each underfrequency tripping range specified in IEEE Std 1547. The evaluated ranges of adjustment for tripping magnitude and duration shall be greater than or equal to the allowable ranges of adjustment for each underfrequency tripping range specified in IEEE Std 1547.

NOTE—Tripping within the “may ride through” or “may trip” regions shown in H.3 of IEEE Std 1547-2018 is allowed.

³⁴The variable t_h is at least 100% of the trip time setting plus 200% the minimum required measurement accuracy (MRA), as specified in Table 3 of IEEE Std 1547-2018 for steady-state conditions. This number may be adjusted to avoid conflict with other trip points.

5.5.2.5 Comments

During the underfrequency trip tests the EUT shall be operated at any power level between 25% and 100% of the EUT nameplate rating. The power levels used during testing shall be high enough to clearly differentiate the EUT's cease to energize response from the response to the frequency-active power function.

5.5.3 Test for low-frequency ride-through

5.5.3.1 Purpose

The purpose of this test is to verify the behavior of the system in response to low-frequency excursions that are outside the normal range of operation of the *area EPS*. The test verifies behavior of the EUT in ride-through regions. Two test procedures are given: one for DER capable of isolated operation, and another for DER not capable of isolated operation.

5.5.3.2 Procedures

5.5.3.3 DER not capable of variable frequency operation while isolated from external sources

These procedures utilize an *ac test source* consisting of variable voltage source and load bank as shown in [Figure G.1](#). The parameter P becomes frequency for this test.

This procedure uses the rate limited step function defined in [A.4](#) of [Annex A](#).

- a) Connect the EUT to *ac test source* according to manufacturer's instructions.
- b) Set or verify that the EUT is programmed using default settings.
- c) Set the frequency droop function and droop values to make the active power change with respect to frequency as small as possible.
- d) Set or verify that all frequency trip settings are set to not influence the outcome of the test.
- e) Operate the *ac test source* at nominal frequency ± 0.1 Hz.
- f) Operate EUT at a power level greater than or equal to 90% of EUT rating and at any convenient power factor. Record the output current of the EUT at the nominal frequency condition.
- g) Adjust the frequency of the *ac test source* from P_N to P_U where P_U is less than or equal to 57 Hz. The source shall be held at this frequency for period t_h , which shall be not less than 299 s.
NOTE—The ROCOF used during steps f) and g) may be used to demonstrate the ROCOF ride through capability of the EUT.
- h) Increase the frequency of the *ac test source* to the nominal frequency ± 0.1 Hz.
- i) Repeat steps f) and g) twice for a total of three tests. During all frequency transitions in steps f) through h) the absolute ROCOF shall be greater than or equal to the ROCOF limit in Table 21 of IEEE Std 1547-2018 and shall be within the demonstrated ROCOF capability of the EUT.

5.5.3.4 DER capable of variable frequency operation while isolated from external sources

DER capable of operation isolated from external sources may use the following test procedure:

- a) Connect the EUT to load bank according to manufacturer's instructions.
- b) Set or verify that the EUT is programmed using default settings.
- c) Set the frequency droop function and droop values to make the active power change with respect to frequency as small as possible.
- d) Set or verify that all frequency trip settings are set to not influence the outcome of the test.
- e) Operate the EUT at nominal frequency ± 0.6 Hz into a load bank load capable of absorbing 100% to 125% of the power rating of the EUT.
- f) Operate EUT at a power level greater than or equal to 90% of EUT rating and at any convenient power factor. Record the output current of the EUT at the nominal frequency condition.
- g) Adjust the frequency of the EUT from P_N to P_U where P_U is less than or equal to 57 Hz. The EUT shall be held at this frequency for period t_h , which shall be not less than 299 s.

NOTE—The ROCOF used during steps f) and g) may be used to demonstrate the ROCOF ride through capability of the EUT.

- h) Increase the frequency of the EUT to the nominal frequency ± 0.6 Hz.
- i) Repeat steps f) and g) twice for a total of three tests.
- j) During all frequency transitions in steps f) through h), the absolute ROCOF shall be greater than or equal to the ROCOF limit in Table 21 of IEEE Std 1547-2018 and shall be within the demonstrated ROCOF capability of the EUT.

5.5.3.5 Requirements

The variable frequency source shall have a nameplate rating greater than or equal to 125% of the EUT. The load bank, if used, shall have ratings sufficient to perform the tests described in 5.5.3.2 as agreed upon by the applicable *testing agency*. Examples of acceptable variable frequency sources are voltage source inverters and generator sets capable of operating at frequencies above and below nominal frequency.

The EUT for this test is the entire DER, including the prime mover or prime energy source, if feasible. Where it is infeasible to test with the actual energy source, a synthetic representation of that source may be substituted. The characteristics of this source shall be specified by the EUT manufacturer. The testing shall identify any vulnerabilities of the prime mover or prime energy source to ride through conditions.

5.5.3.6 Criteria

An EUT shall be considered in compliance when the EUT rides through the abnormal frequency excursions with a magnitude and duration not less than those specified in 6.5.2 of IEEE Std 1547-2018.

5.5.3.7 Comments

When varying the frequency of the *ac test source* or EUT, the ROCOF should be kept below the ROCOF capability of the EUT to avoid nuisance tripping. The ROCOF used in the ride-through tests shall exceed the minimum ROCOF capability required in 6.5.2.5 of IEEE Std 1547-2018, to satisfy the ROCOF ride-through test requirements for the EUT's *Abnormal Operating Performance Category*.

5.5.4 Test for high-frequency ride-through

5.5.4.1 Purpose

The purpose of this test is to verify the behavior of the system in response to high-frequency excursions that are outside the normal range of operation of the *area EPS*. The test verifies behavior of the EUT in ride-through regions. Two procedures are given: one for DER capable of isolated operation and another for DER not capable of isolated operation. For the latter, a variable frequency source is required. Examples of acceptable variable frequency sources are voltage source inverters and generator sets capable of operating at frequencies above and below nominal frequency.

5.5.4.2 Procedures

This procedure utilizes an *ac test source* consisting of variable frequency source.

This procedure uses the rate limited step function defined in A.4 of Annex A. The parameter P becomes frequency for this test.

5.5.4.3 DER not capable of variable frequency operation while isolated from external sources

DERs that are not capable of isolated operation shall use the following procedure:

- a) Connect the EUT to *ac test source* according to manufacturer's instructions.
- b) Set or verify that the EUT is programmed using default settings.
- c) Set the frequency droop function and droop values to make the active power change with respect to frequency as small as possible.
- d) Set or verify that all frequency trip settings are set to not influence the outcome of the test.
- e) Operate the *ac test source* at nominal frequency ± 0.1 Hz.
- f) Operate EUT at any convenient power level between 90% and 100% of EUT rating and at any convenient power factor. Record the output current of the EUT at the nominal frequency condition.
- g) Adjust the source frequency from P_N to P_U where f_U is greater than or equal to 61.8 Hz. The source shall be held at this frequency for period t_h , which shall be not less than 299 s.

NOTE—The ROCOF used during steps f) and g) may be used to demonstrate the ROCOF ride through capability of the EUT.

- h) Decrease the frequency of the *ac test source* to the nominal frequency ± 0.1 Hz.
- i) Repeat steps f) and g) twice for a total of three tests.
- j) During all frequency transitions in steps f) through h), the ROCOF shall be greater than or equal to the ROCOF limit in Table 21 of IEEE Std 1547-2018 and shall be within the demonstrated ROCOF capability of the EUT.

5.5.4.4 DER capable of variable frequency operation while isolated from external sources

DERs that are capable of isolated operation may use the following procedure:

- a) Connect the EUT to a load bank according to manufacturer's instructions.
- b) Set or verify that the EUT is programmed using default settings.

- c) Set the frequency droop function and droop values to make the active power change with respect to frequency as small as possible.
- d) Set or verify that all frequency trip settings are set to not influence the outcome of the test.
- e) Operate the EUT at nominal frequency $\pm 0.6 \text{ Hz}$ ³⁵ into a load bank load capable of absorbing 100% to 125% of the power rating of the EUT.
- f) Operate EUT at any convenient power level between 90% and 100% of EUT rating and at any convenient power factor. Record the output current of the EUT at the nominal frequency condition.
- g) Adjust the EUT frequency from P_N to P_U where P_U is greater than or equal to 61.8 Hz. The EUT shall be held at this frequency or period t_H , which shall be not less than 299 s.
NOTE—The ROCOF used during steps f) and g) may be used to demonstrate the ROCOF ride through capability of the EUT.
- h) Decrease the frequency of the EUT to the nominal frequency $\pm 0.6 \text{ Hz}$.
- i) Repeat steps f) and g) twice for a total of three tests.
- j) During all frequency transitions in steps f) through h), the ROCOF shall be greater than or equal to the ROCOF limit in Table 21 of IEEE Std 1547-2018 and shall be within the demonstrated ROCOF capability of the EUT.

5.5.4.5 Requirements

The variable frequency source shall have a nameplate rating greater than or equal to 125% of the EUT. The load bank, if used, shall have a capacity greater than or equal to 125% of the power rating of the EUT. Examples of acceptable variable frequency sources are voltage source inverters and generator sets capable of operating at frequencies above and below nominal frequency.

The EUT for this test is the entire DER, including the prime mover or prime energy source, if feasible. Where it is infeasible to test with the actual energy source, a synthetic representation of that source may be substituted. The characteristics of this source shall be specified by the EUT manufacturer. The testing shall identify any vulnerabilities of the prime mover or prime energy source to ride through conditions.

5.5.4.6 Criteria

An EUT shall be considered in compliance when the EUT rides through the abnormal frequency excursions with a magnitude and duration not less than those specified in 6.5.2 of IEEE Std 1547-2018.

5.5.4.7 Comments

When varying the frequency of the *ac test source* or EUT, the ROCOF should be kept below the ROCOF capability of the EUT to avoid nuisance tripping. The ROCOF used in the ride-through tests shall exceed the minimum ROCOF capability required in 6.5.2.5 of IEEE Std 1547-2018, to satisfy the ROCOF ride-through test requirements for the EUT's *Abnormal Operating Performance Category*.

5.5.5 Test for rate of change of frequency (ROCOF)

Compliance with the minimum ROCOF capability required in 6.5.2.5 of IEEE Std 1547-2018 is verified using the results from one or more of the frequency ride-through tests in 5.5.3 and 5.5.4. The absolute ROCOF used during the frequency ride-through test used for compliance verification shall be at or above

³⁵For EUTs capable of independent variable frequency operation, a minimum ride-through capability may be demonstrated without need for precise frequency regulation during the test.

the ROCOF limit as specified in 6.5.2.5 of IEEE Std 1547-2018 for the EUT's *abnormal operating performance category*.

5.5.6 Test for voltage phase-angle change ride-through

The phase-angle change ride-through (PCRT) test verifies the ability of the EUT to ride through sudden voltage phase-angle changes without tripping in accordance with the requirements in 6.5.2.6 of IEEE Std 1547-2018.

The 60° phase-angle changes required in this test procedure may result in phase-to-phase voltages that approach both undervoltage and overvoltage trip limits. The phase-to-phase or phase-to-neutral voltages supplied by the ac source may be modulated to any voltage needed to avoid nuisance voltage tripping during the testing.

During the test, the settings for magnitude and duration of undervoltage and overvoltage tripping functions may be set so as not to influence the outcome of the test (subject to the ranges of allowable settings from Tables 11–13 IEEE Std 1547-2018, as applicable). Active and reactive power control functions and frequency trip settings shall be set to the default states and values specified in IEEE Std 1547. Tripping functions, including those for circuit protection and those specifically required by IEEE Std 1547, and the associated voltage and frequency monitoring shall not be disabled. This includes tripping in response to unintentional islanding.³⁶ Any active frequency or phase shift controls present in the EUT (for example as may be used in unintentional islanding controls) may be disabled.

Two variations of the test are provided. The first variation (5.5.6.1) uses an *ac test source* capable of independent phase-angle change and may be performed for all types of DER. The second variation (5.5.6.2) uses an *ac test source* that is not capable of independent phase-angle changes, such as an actual utility or a rotating machine. The second variation may be performed for multi-phase DERs and single-phase DERs that are allowed per the manufacturer's specification to be connected to form a multi-phase system. Either variation provides full compliance with the requirements of the base standard.

For rotating machinery based DERs that are not doubly-fed, the PCRT test may be run using signal injection applied to the DER control subsystem(s) responsible for voltage and frequency measurement and protection instead of inducing an actual phase-angle change. A simulated prime mover in meeting the requirements of 4.6.2 may be used in this test. The manufacturer shall identify all signal injection test ports. For all other types of DER, signal injection methods shall not be used unless the:

- *Testing agency* is evaluating a change to the EUT control circuit or to the firmware that can be re-evaluated using signal injection;
- EUT version before the change had already passed the PCRT *type test*; and
- Firmware has been evaluated to an embedded software standard and under a quality control program by the *testing agency*.

The ride-through tests shall be performed at any active power level greater than 90% of the EUT nameplate active power rating and at any convenient power factor greater than 0.90.

5.5.6.1 Test using an ac test source capable of independent phase-angle change (variation 1)

If the phase-angle change causes nuisance tripping due to phase-to-phase or phase-to-neutral overvoltages or undervoltages, the test may be repeated with the remaining phases shifted simultaneously with the phase under test by up to 30° to avoid the nuisance tripping. Table 9 lists the voltage phase-angle conditions that

³⁶This includes but is not limited to tripping based on phase jump, vector shift, or rate of change of frequency.

shall be applied on the EUT terminals. Each test condition in the table shall be applied in the following test sequences: A-B-A, A-C-A, A-D-A, A-E-A, and A-F-A. Each test condition within a sequence shall be run continuously. For single-phase EUTs, conduct only the A-B-A test sequence for the applicable phases to which the EUT is connected. Individual test sequences may be performed in any convenient order and run separately, or may be combined serially into one or more continuous series to cover all test conditions. For example: Series A-B-A-C-A-D-A followed by series A-E-A-F-A, etc.

Step changes from one voltage phase angle to the next shall be as short as possible and shall not exceed 1 cycle. Each test condition shall be sustained for at least the respective duration specified in Table 9. Tolerance on voltage phase-angles specified in Table 9 shall be $\pm 3^\circ$. Positively damped oscillations in voltage phase-angle and magnitude are permitted.

Table 9—PCRT test conditions (variation 1)

Test condition	Phase A voltage angle (degrees, relative to initial phase A angle) (see NOTE 1)	Phase B voltage angle (degrees, relative to initial phase A angle)	Phase C voltage angle (degrees, relative to initial phase A angle)	Duration (s)
A	0	120	240	30–40
B	60 or 300	120	240	0.320–0.500
C	0	60 or 180	240	0.320–0.500
D	0	120	180 or 300	0.320–0.500
E	20	140	260	55–65
F	340	100	220	55–65

NOTE 1—All single-phase angle values are specified in the same direction, leading or lagging relative to the initial phase angle of an arbitrarily assigned phase A during test condition A.
 NOTE 2—In some test cases two phase angles are given to allow for either forward (leading) or reverse (lagging) phase shift, and either test condition may be used.

Test conditions C through F are not required for single-phase EUTs.

This test sequence shall be repeated five times. The point on wave phase angle at which each phase jump occurs shall be random.

5.5.6.2 Test using an ac test source not capable of independent phase-angle change (variation 2)

This test shall be conducted in individual sequences. During all tests, the input power source, such as the dc source, must be sized and operated such that it does not limit the EUT output. Both tests apply to multi-phase DERs, and to single-phase DERs that are allowed per the manufacturer’s specification to be connected to form a three-phase system. In the latter case, it is required to perform the tests with three single-phase DER connected as such.

Table 10 lists the voltage phase-angle conditions that are applied to the EUT terminals by use of additional equipment so as not to require phase-angle change from the *ac test source*. Test condition A represents the nominal state of the *ac test source* and the subsequent conditions represent the abnormal states. The test conditions in the table shall be applied in the following test sequences: A-B-A, A-C-A, A-D-A, E-A, F-A. Each test condition within a sequence shall be run continuously. Individual test sequences may be performed in any convenient order and run separately.

Test sequences A-B-A, A-C-A and A-D-A verify two phase-angle changes each, so any two of these are sufficient to test all single-phase phase-angle changes. Test conditions A-D shall be sustained for at least the respective duration specified in Table 10. Test sequences E-A and F-A represent three-phase phase-

jumps and allow for drifting of the phase to test condition E or F before jumping within a sub cycle-to-cycle timeframe back to test condition A.

Table 10—PCRT test conditions (variation 2)

Test condition	Phase A voltage angle (degrees, relative to initial phase A angle) (see NOTE 1)	Phase B voltage angle (degrees, relative to initial phase A angle)	Phase C voltage angle (degrees, relative to initial phase A angle)	Duration (s)
A	0	120	240	30-40
B	60 or 300	60 or 300	240	0.320–0.500
C	0	180 or 60	180 or 60	0.320–0.500
D	300 or 180	120	300 or 180	0.320–0.500
E	20	140	260	N/A
F	340	100	220	N/A

NOTE 1—All phase angle values are specified in the same direction, leading or lagging relative to the initial phase angle of an arbitrarily assigned phase A during test condition A.
NOTE 2—In some test cases two phase angles are given to allow for either forward (leading) or reverse (lagging) phase shift and either test condition may be used.

Step changes from one voltage phase angle to the next shall be as short as possible and shall not exceed 1 cycle. Tolerance on voltage phase-angles specified in the procedure below shall be $\pm 3^\circ$. Positively damped oscillations in voltage phase-angle and magnitude are permitted. The test sequences are described below:

- a) **Phase-phase fault test (test sequences A-B-A, A-C-A, A-D-A):** This test is a short-circuit between two phases. This causes one phase to shift forward (leading) by 60 degrees and the other affected phase backward (lagging) by 60 degrees, while the positive sequence phase-angle remains unchanged. Thus, two phase-angle changes are tested simultaneously.
 - 1) Install the setup according to [Figure G.1 \(Annex G\)](#) and allow the EUT to come to steady-state output at the specified output power at test condition A.
 - 2) Apply the fault (test condition B, C or D) by causing two of the phases to come together and remain connected for a duration of 0.320–0.500 s.
 - 3) Return to test condition A.
 - 4) Repeat steps 1 through 3 four times for a total of five samples. In each test, the fault shall occur at a different point on the voltage waveform.
 - 5) Repeat steps 1 through 4 for another combination of phases (i.e., one of the remaining test sequences).

- b) **Three-phase phase-jump test (test sequences E-A, F-A):** This test causes a sudden phase shift on all three phases.
 - 1) Install the setup according to [Figure 7 \(5.10.2.2\)](#) and allow the EUT to come to steady-state output at the specified output power with all switches closed. The load should be adjusted so that minimal or no current flows towards the *ac test source* through S3.
 - 2) Open switch S3 so that the EUT is disconnected from the *ac test source* and the positive sequence phase-angle starts shifting.
 - 3) Allow the phase-angle to shift 20 degrees from that of test condition A, reaching test condition E or F.
 - 4) Close switch S3 returning back to test condition A.
 - 5) Repeat steps 1 through 4 four times for a total of five samples. In each test, the fault shall occur at a different point on the voltage waveform.
 - 6) Repeat steps 1) through 5) for a phase-jump in the other direction (i.e., the remaining test sequence).

5.5.6.3 Requirements

The *ac test source*³⁷ shall not be required to comply with the requirements of 4.6.1. The *ac test source* shall meet the following requirements:

- Where test signal residual voltages are specified as a minimum voltage the average of the rms voltage during the test interval shall be maintained at or below the specified minimum value.
- Where test signal residual voltages are specified as a range of voltages the average of the rms voltage during the test interval shall be maintained within the specified voltage range.

The EUT for this test is the entire DER, including the prime mover or prime energy source, if feasible. Where it is infeasible to test with the actual energy source, a synthetic representation of that source may be substituted. The characteristics of this source shall be specified by the EUT manufacturer. The testing shall identify any vulnerabilities of the prime mover or prime energy source to ride through conditions.

Where the *ac test source* is not capable of independent phase control per 5.5.6.2, the following alternative test set up may be used. The alternative testing setup for the phase-phase fault test shall be sized so that it never enters any current-, voltage-, or power-limiting mode at any time during the test. The *ac test source* shall be configured so that the faulted phase-angles have shifted to within 6° (2 times the permitted tolerance) of one another.

The testing setup for the three-phase phase-jump test is a modification of that presented in Figure 7 (5.10.2.2). Switch S2 is not required, but if present, must remain closed throughout the test. The inductive and capacitive loads are not required but may be used to modify the islanding behavior during this test. If the inductive and capacitive loads are used, switches SIR, SIC, and SIL must all remain closed. The resistive load must be capable of sinking all the power the EUT is exporting. The EUT must remain connected throughout.

5.5.6.4 Criteria

The EUT shall be considered in compliance if it does not trip for the duration of all tests, per 6.5.2.6 of IEEE Std 1547-2018.

Active and reactive current oscillations that are positively damped are permitted during the disturbance and post-disturbance periods.

The EUT shall be permitted to momentarily cease to energize the *area EPS* as specified in 6.5.2.6 of IEEE Std 1547-2018. If the DER ceases to energize the *area EPS*, it shall be considered in compliance only if it restores its apparent current output to greater than 80% of the pre-disturbance active current within 0.5 s as specified in 6.5.2.6 of IEEE Std 1547-2018.

5.5.6.5 Comments

The stiffness of the *ac test source* relative to the DER rating is an important factor in the ability of the source to maintain a steady voltage during a voltage phase-angle change. It is recommended that the impedance of the ac power source at the EUT terminals (with or without transformer) be less than 0.33 p.u. based on the EUT nameplate rating.³⁸

³⁷Additional guidance on test equipment selection and setup may be found in Annex G and in IEC 62910.

³⁸The base per unit impedance is the square of the EUT nominal voltage divided by the nameplate apparent power rating.

5.6 Enter service

5.6.1 Purpose

The tests in this subclause confirm compliance with the following *enter service* requirements (subclause numbers in parentheses refer to IEEE Std 1547-2018):

- Capability to disable permit service (4.6.1)
- Prioritization of DER responses (4.7 a)
- Enter service criteria (4.10.2)
- Performance during entering service (4.10.3)

This test also confirms that disabling the *permit service* setting persists following a power cycle.

5.6.2 Procedure

This test procedure specified below shall be repeated for each test case in [Table 11](#). Odd-numbered test cases verify correct application of the enter service (ES) period (ramp). Even-numbered test cases verify correct application of the ES randomized time delay.³⁹ If the randomized delay time is implemented, test case 4 shall be repeated for a sufficient number of trials, with a minimum of ten trials, such that the mean delay time of all trials is between 400 s and 600 s, and the standard deviation of the delay times is greater than 250 s.⁴⁰

Exception 1: For EUT that do not implement an ES period (ramp), test cases 1, 3, and 5 shall use the ES randomized delay parameters from test cases 2, 4, and 6, respectively.

Exception 2: For EUT that do not implement a randomized delay, test cases 2, 4, and 6 shall use the ES period (ramp) parameters from test cases 1, 3, and 5, respectively.

The “Enter service criteria settings” columns of [Table 11](#) contain various settings for the enter service criteria as specified in Table 4 of IEEE Std 1547-2018.⁴¹ Initial voltage and frequency values in [Table 11](#) are designed so that one of the two is outside the ES criteria range by $2\times$ MRA. Then during the test, the value moves to the final voltage or frequency value, which is inside the ES criteria range by $2\times$ MRA.

The use of *signal injection test methods* shall be permitted in this test, but the use of such methods shall not remove the requirement for the EUT to produce active power during the test.

³⁹The ES period (ramp) and the ES randomized time delay are mutually exclusive: when one is enabled, the other is not.

⁴⁰This is intended to confirm that the randomized delay follows a uniform probability distribution.

⁴¹The ES criteria settings in [Table 11](#) are not intended to require DER measure voltage or frequency more accurately than specified in Table 3 of IEEE Std 1547-2018.

Table 11 —Enter service test cases

Test case	ES delay (s)	ES period (ramp) (s)	Randomized delay setting (s)	Enter service criteria settings				AC test source values			
				ES voltage high (p.u.)	ES voltage low (p.u.)	ES frequency high (Hz)	ES frequency low (Hz)	Initial voltage (p.u.)	Final voltage (p.u.)	Initial frequency (Hz)	Final frequency (Hz)
1 (Defaults)	300	300	NA	1.05	0.917	60.1	59.5	0.897	0.937	60.0	60.0
2	0	NA	300	1.05	0.917	60.1	59.5	1.0	1.0	59.48	59.52
3 (Maxima)	600	1000	NA	1.06	0.95	61.0	59.9	1.08	1.04	60.0	60.0
4	0	NA	1000	1.06	0.95	61.0	59.9	1.0	1.0	61.02	60.98
5 (Minima)	0	1	NA	1.05	0.88	60.1	59.0	0.86	0.90	60.0	60.0
6	0	NA	1	1.05	0.88	60.1	59.0	1.0	1.0	58.98	59.92

NOTE—Voltages are in per unit (p.u.) of the nominal EUT ac voltage.

Test procedures are as follows:

- a) Connect the EUT according to the instructions and specifications provided by the manufacturer.
- b) Disable the permit service setting. Begin recording EUT active power, ac voltage, and frequency.
- c) Establish nominal operating conditions as specified by the manufacturer at the terminals of the EUT. Make available sufficient input power for the EUT to reach its rated active power.
- d) Apply the DER ES criteria settings, ES delay, and ES period or randomized delay specified in [Table 11](#) for the test case under test.
- e) Confirm that the EUT does not begin to export power by waiting for no less than the greater of:
 - 1) 60 s or
 - 2) $2 \times$ (the ES delay time) plus the ES randomized delay setting (if enabled).
- f) Set the *ac test source* to the initial voltage and frequency specified in [Table 11](#).
- g) Enable the permit service setting.
- h) Confirm that the EUT does not begin to export power by waiting for no less than the greater of:
 - 1) 60 s or
 - 2) $2 \times$ (the ES delay time) plus the ES randomized delay setting (if enabled).
- i) Set the *ac test source* to the final voltage and frequency specified in [Table 11](#) for a duration equal to 25% of the ES delay. Return the *ac test source* to the initial voltage and frequency specified in [Table 11](#) for a duration of 0.05 s to 0.1 s to allow the ES delay timer to restart. This step shall be omitted for test cases where the ES delay setting is zero.
- j) Set the *ac test source* to the final voltage and frequency specified in [Table 11](#). Wait until EUT active power stabilizes at its rated value.
- k) Disable the permit service setting. Wait until the EUT ceases to energize the *ac test source*.
- l) Enable the permit service setting. Wait 5 s. This step shall be omitted for test cases where the ES delay setting is zero.

5.6.3 Requirements

When transitioning between frequencies, the rate-of-change-of-frequency (ROCOF) should not exceed the ROCOF ride-through requirement in Table 21 of IEEE Std 1547-2018 for the applicable operating performance category.

5.6.4 Criteria

In steps b) through i) of 5.6.2, the EUT shall not export active power to the *ac test source* or initiate synchronization.

In step j), the EUT shall not begin to export active power until at least 98.5% of the ES delay has elapsed, starting from the point in time when the *ac test source* voltage and frequency returned to within the ES criteria range after the last excursion outside the ES criteria range. This also confirms that the EUT delay counter restarted following the excursion in step i) outside the ES criteria range.

In step j), the measured EUT active power shall comply with all requirements in 4.10.3 c) in IEEE Std 1547-2018, including requirements on average rate-of-change of active power and maximum active power step increase. For test cases where the ES randomized delay is used, the active power shall comply with 4.10.3c Exception 1 in IEEE Std 1547-2018. For test cases where the ES period (ramp) is used, the EUT shall not reach its rated active power before a time has elapsed equal to 98.5% of the sum of the ES intentional delay time and the ES period, starting from the point in time when the *ac test source* voltage and frequency returned to within the to the ES criteria range for the test case.

In step k), the EUT shall cease to energize the *ac test source* (i.e., active power shall fall to zero) within the time specified in 4.6.1 of IEEE Std 1547-2018.

In step l), the EUT shall not export active power to the *ac test source* or initiate synchronization within the specified 5 s wait time.⁴²

5.7 Synchronization

5.7.1 General

The purpose of the tests in this subclause is to demonstrate that the EUT will synchronize to the *area EPS* according to the tolerances specified in Table 5 of IEEE Std 1547-2018.⁴³ This test is only applicable to DERs capable of producing fundamental-frequency voltage independently of the *area EPS*.

Three variations of the test are provided. The first variation (5.7.2) assumes a simulated generator source and would be performed, for example, on a discrete relay or multifunction controller with synchronization control function. The second variation (5.7.3) assumes an actual generator source is used. The third variation (5.7.4) is designed for testing of equipment in which the synchronizing functions cannot be switched off or the sensing voltage cannot be conveniently disconnected.

NOTE—For *DER system design evaluation* and determination of the need for synchronization *commissioning test*, the synchronization test may be waived by the *area EPS operator* if paralleling does not cause rapid voltage change and flicker exceeding the limits of 7.2.2 and 7.2.3, respectively, in IEEE Std 1547-2018.

⁴²The intent of step l) is to verify that when permit service is disabled and then enabled, the EUT does not immediately enter service in cases when a nonzero ES delay is applied.

⁴³Synchronization tests are intended to be conducted under balanced conditions.

5.7.2 Synchronization control function test using simulated generator source (variation 1)

5.7.2.1 Purpose

The purpose of these tests is to demonstrate that interconnection equipment will synchronize to the *area EPS* across an open *paralleling device* (e.g., a power circuit breaker), within allowable limits of voltage, frequency, and phase-angle difference before the *paralleling device* is allowed to close. The procedure is intended for a discrete or multifunction interconnection control device that includes a synchronization function and may be used in laboratory tests with simulated generator equipment and an *ac test source*.

If the EUT does not include a *paralleling device*, the acceptability of the EUT for a specific site depends on the speed of operation of the *paralleling device* to be used with the EUT.

5.7.2.2 Procedure

The procedure is as follows:

- a) Connect the EUT according to the instructions and specifications provided by the manufacturer.
- b) Connect the test equipment to monitor the *paralleling device* close command, the phase relationship between simulated generator output and *ac test source*, the frequency of each source, and the voltage of each source.
- c) Set *ac test source* to operate at nominal voltage and frequency. Record applicable settings.
- d) Demonstrate that the equipment does not close outside of the voltage allowable range defined in Table 5 in IEEE Std 1547-2018, but does close within that allowable range. By holding the voltage and frequency of the *ac test source* at constant nominal values and varying the voltage of the simulated generator source, the test demonstrates that the EUT does not initiate closing outside of acceptable ranges of voltage and does close within acceptable ranges. The test demonstrates that the EUT functions properly both from a low voltage that is raised to within an acceptable value and from a high voltage that is lowered to within an acceptable value. The following process may be used for testing the voltage:
 - 1) Set the voltage and frequency of the *ac test source* to nominal values.
 - 2) Set the voltage of the simulated generator source to a value above the *ac test source* voltage so that the voltage difference is outside the allowable range, but the simulated generator voltage is below the overvoltage trip limit of the EUT (if so equipped).⁴⁴ The voltage difference should be at least twice the MRA of the EUT.⁴⁵
 - 3) Set and hold the frequency of the simulated generator source to that of the *ac test source* so that frequency difference and phase angle⁴⁶ are within the limits allowed by the requirements of IEEE Std 1547. Include an allowance for EUT accuracy so that frequency and phase angle do not inadvertently keep the EUT from initiating a *paralleling device* closure.
 - 4) Verify for a period of at least 3 minutes that the EUT does not initiate closing.
 - 5) Gradually reduce the generator source voltage until the voltage difference is within the allowable values of IEEE Std 1547 including an allowance for EUT accuracy. The voltage ramp rate should be controlled to allow reliable indication of the point at which *paralleling device* closure is initiated.
 - 6) Record the voltage and frequency for the *ac test source* and simulated generator, as well as the voltage, frequency, and phase-angle differences between the two sources at the point at which the EUT initiates *paralleling device* closure.

⁴⁴In some cases the overvoltage trip setting may need to be widened to accommodate this testing scenario.

⁴⁵If the EUT stated measurement accuracy is 1%, the initial voltage difference should be at least 2% greater than the allowable limit.

⁴⁶If the generator source frequency and utility source frequency are not identical, phase angle will periodically be within allowable limits.

- 7) Repeat steps 1) through 6) two times for a total of three sets of readings.
 - 8) Repeat steps 1) through 7) except with the initial simulated generator source voltage set at a value below the *ac test source* voltage so that the voltage difference is outside the allowable range, but the generator voltage is above the undervoltage trip limit of the EUT.
- e) Demonstrate that the equipment does not close outside of the frequency and phase-angle allowable range defined in IEEE Std 1547, but does close within that allowable range. By holding the voltage and frequency of the *ac test source* constant and varying the frequency of the generator source, the test demonstrates that the EUT does not initiate *paralleling device* closure outside of acceptable ranges of frequency difference and phase angle and does initiate *paralleling device* closure within acceptable ranges. The test demonstrates that the EUT functions properly starting from both a low frequency that is raised to within an acceptable value and from a high frequency that is lowered to within an acceptable value.
- 1) Set the voltage and frequency of the *ac test source* to nominal values.
 - 2) Set the simulated generator source voltage to that of the *ac test source*.
 - 3) Set the frequency of the simulated generator to a value above the *ac test source* frequency so that the frequency difference is outside the allowable range, but the simulated generator frequency is below the overfrequency trip limit of the EUT (if so equipped). The frequency difference should be at least twice the MRA of the EUT.
 - 4) Set and hold the voltage of the simulated generator to that of the *ac test source* so that voltage difference is within the limits allowed by the requirements of IEEE Std 1547-2018. Include an allowance for EUT accuracy so that voltage difference does not inadvertently keep the EUT from initiating a *paralleling device* closure.
 - 5) Verify for a period of at least 3 minutes that the EUT does not initiate *paralleling device* closure.
 - 6) Gradually reduce the simulated generator frequency until the frequency difference is within the allowable values of IEEE Std 1547 including an allowance for EUT accuracy. The frequency ramp rate should be controlled to allow reliable indication of both the frequency and phase angle at which *paralleling device* closure is initiated.
 - 7) Record the voltage and frequency for the *ac test source* and simulated generator, as well as the voltage, frequency, and phase-angle differences between the two sources at the point at which the EUT initiates *paralleling device* closure.
 - 8) Repeat steps 1) through 7) two times for a total of three sets of readings.
 - 9) Repeat steps 1) through 8) except with the initial simulated generator frequency set at a value below the *ac test source* frequency so that the frequency difference is outside the allowable range, but the simulated generator frequency is above the underfrequency trip limit of the EUT.

5.7.2.3 Requirements

Programmable arbitrary waveform generators (*multiphase* as necessary) may be used to provide simulated generator and *ac test source* voltage waveforms. The waveform generator shall provide voltage and frequency signals in a form compatible with the EUT.

Simulated generator voltage and frequency control shall come either from the EUT or, for passive devices, from a control computer programmed to provide the desired waveforms.

The *ac test source* steady-state operating performance shall meet the manufacturer's standards for frequency and voltage stability at no load for at least 15 minutes.

5.7.2.4 Criteria

The testing shall demonstrate that the equipment complies with the requirements of IEEE Std 1547 for synchronization parameter limits.

Test results shall demonstrate that the EUT does not initiate closure out of range for any parameter during any test.

5.7.2.5 Comments

Since the EUT in this test procedure may not incorporate a *paralleling device*, the documentation should note that, when applied, the phase angle at the instant of closing would be different from what is recorded during this test due to the closing time required for the anticipated *paralleling device*. The EUT may incorporate provisions to allow compensation for *paralleling device* operation time.

If parallel device closing time compensation was used, verify that the synchronization device accurately predicted the proper closing angle prior to the specified phase-angle window. Following is a sample calculation:

Given:

paralleling device closing time = 5 cycles

frequency differential at time of parallel device close command = 0.10 Hz

maximum phase-angle window = 10°

Then:

phase rotation rate = frequency differential \times 360° = 0.10 Hz \times 360° = 36°s⁻¹

paralleling device closing time = 5 cycles @ 60 Hz = 0.0833 s

predictive closing angle = 36°s⁻¹ \times 0.0833 s = 3°

Therefore, if the maximum allowable phase angle at *paralleling device* closure is 10° and the equipment is approaching synchronization, the initiation point could be 10° + 3° = 13°. If the equipment was moving away from synchronization, maximum deviation at initiation would be 10° - 3° = 7°.

5.7.3 Synchronization control function test using actual generator equipment (variation 2)

5.7.3.1 Purpose

The purpose of these tests is to demonstrate that synchronous generator equipment synchronizes to the *area EPS* across an open *paralleling device* (e.g., a power circuit breaker), according to the requirements of IEEE Std 1547.

These procedures may also be used with separately excited induction equipment or with inverter equipment that is able to operate in isolation from the *area EPS* and to resynchronized with the *area EPS*.

5.7.3.2 Procedure

The procedure is as follows:

- a) Connect the EUT according to the instructions and specifications provided by the manufacturer. Installation must include verification of the ratings, phasing, and connection of the current transformers (CTs) and voltage transformers (VTs) (if used) in the system that provides input to the control and protection functions.
- b) Connect the test equipment to monitor the *paralleling device* close command, the phase relationship between sources, the frequency of each source, and all phases of the voltage of the actual generator and of the *ac test source*.
- c) Set actual generator to operate at rated voltage and frequency. Verify that the actual generator operates within the frequency and voltage regulation specifications of the manufacturer while operating in isolation from the *area EPS*. Record applicable settings, and record voltage and frequency regulation performance.
- d) Measure and record the closing time of the *paralleling device*. Repeat two times for a total of three tests.
- e) Set the actual generator to the nominal frequency and voltage of the *ac test source*. Disable *paralleling device* closure and initiate synchronizing action. Verify that the synchronizing function operates correctly to close the *paralleling device* when the actual generator is properly synchronized. If the *paralleling device* includes a test position that does not allow connection to the *ac test source*, use of the test position to verify *paralleling device* operation is acceptable.
- f) Enable *paralleling device* closing.
- g) Demonstrate that the EUT does not close outside of the allowable range for voltage and does close within the voltage range values required by IEEE Std 1547-2018. The required process holds the frequency of the actual generator constant and nearly identical to the *ac test source* and, by varying the voltage, demonstrates that the EUT does not initiate closing outside of acceptable ranges of voltage, and does close within acceptable parameters. The test demonstrates that the EUT functions properly both from a low voltage that is raised to an acceptable value, and from a high voltage that is lowered to within acceptable range. The following process may be used (at various points in the following procedure, it may be necessary to reset various parameters to proceed):
 - 1) If applicable, disable the synchronizing function.
 - 2) Set and hold the voltage of the actual generator to a value so that the voltage difference is outside the allowable range, but within the acceptable voltage and frequency operating range of the EUT. The value selected should be higher than the allowable range and high enough so that the accuracy of the EUT does not inadvertently initiate operation.
 - 3) Set and hold the frequency of the actual generator to that of the *ac test source*. Maintain the phase angle to within the allowable limits of IEEE Std 1547-2018.
 - 4) Verify for a period of at least 3 minutes that the EUT does not initiate closing.
 - 5) Gradually reduce the voltage difference between the two sources to within the allowable values of IEEE Std 1547-2018. The rate of ramp of the voltage parameter should be controlled to a value that allows reliable indication of the initiation point. Record the voltage differential at the time of initiation of closure.
 - 6) Repeat steps 1) through 5) two times for a total of three sets of readings.
 - 7) Repeat steps 1) through 6) except with the initial actual generator voltage below the *ac test source* voltage. The value should be lower than the allowable range and should be selected so that the accuracy of the EUT does not inadvertently initiate operation.
- h) Demonstrate that the EUT does not close outside of the allowable range due to improper frequency sensing or phase-angle sensing and does close within the range of allowable values in IEEE Std 1547. The required process holds the voltage of the simulated generator constant and nearly identical to the *ac test source* and, by varying the frequency, demonstrates that the equipment does not initiate closing out of acceptable ranges of frequency and phase angle and does close within acceptable parameters. The test demonstrates that the EUT functions properly

both from a low frequency that is raised to an acceptable value and from a high frequency that is lowered to within acceptable range. The following process may be used:

- 1) Set the frequency of the actual generator frequency to a value so that the frequency difference is outside the allowable range, but within the acceptable voltage and frequency operating range of the EUT. The value selected should be higher than the allowable range and high enough so that the accuracy of the EUT does not inadvertently initiate operation.
- 2) Set the voltage of the generator source to that of the *ac test source*.
- 3) Hold the voltage and frequency constant. Verify for a period of at least 3 minutes that the interconnection equipment does not initiate closing. (This step may require disabling the automatic synchronizing function of the generator.)
- 4) Gradually reduce the frequency difference between the two sources to within the allowable values of IEEE Std 1547. The ramp rate of the frequency parameter should be controlled to a value that allows reliable indication of the initiation point. Record the frequency differential and phase-angle deviation at the time of initiation of closure.
- 5) Repeat steps 1) through 4) except with the initial actual generator frequency below the *ac test source* frequency. The value should be lower than the allowable range and should be selected so that the accuracy of the EUT does not inadvertently initiate operation.
- 6) Repeat this test procedure two times for a total of three tests.

5.7.3.3 Requirements

If used, the *ac test source* shall meet the requirements of 4.6.1.

If an actual *area EPS* source is used, the *area EPS* source must remain within the undervoltage, overvoltage, underfrequency, and overfrequency trip limits defined by IEEE Std 1547.

The *ac test source* frequency should be set at nominal and maintained within ± 0.1 Hz.

The measurement system shall meet the requirements of 4.6.3.

5.7.3.4 Criteria

The testing shall demonstrate that the equipment complies with the requirements of IEEE Std 1547 for synchronizing performance. Test results shall demonstrate that the EUT does not initiate closure out of allowable range specified in Table 5 of IEEE Std 1547-2018 for any parameter during any test.

5.7.3.5 Comments

Many potential application issues affect the performance of the synchronizing equipment: in particular, phase rotation of generator equipment relative to the grid, phasing of potential transformers serving protection and control equipment, and many other factors. Therefore, it is critical that attention be paid to the manufacturer's installation instructions and system design drawings to avoid out-of-phase paralleling of the generator equipment to the *area EPS*.

5.7.4 Synchronization control function test for equipment with no synchronizing disable capability (variation 3)

5.7.4.1 Purpose

The purpose of this test is to demonstrate that the EUT synchronizes to the *area EPS* across an open *paralleling device*, within allowable limits of voltage, frequency, and phase-angle difference before the *paralleling device* is allowed to close. The procedure is intended for equipment that automatically synchronizes when a reference voltage source is available, maintains synchronization prior to connecting with the *area EPS*, and does not include a means to disable or disconnect the synchronizing function.

5.7.4.2 Procedure

The procedure is as follows:

- a) Install and adjust the EUT according to the manufacturer's recommendations and specifications.
- b) Connect test equipment to monitor the *paralleling device* close command, the phase relationship between EUT output and *ac test source*, the frequency difference, voltage difference, and phase angle between the sources.
- c) Set *ac test source* to operate at nominal voltage and frequency. Record applicable settings.
- d) Disconnect the *ac test source* from the EUT.
- e) Enable all monitoring equipment. Reapply the *ac test source* and record all required parameters (i.e., voltage, frequency, and phase-angle differences) during the paralleling operation.
- f) Repeat this test procedure two times for a total of three tests.

5.7.4.3 Requirements

If used, the *ac test source* shall meet the requirements of 4.6.1. The measurement system shall meet the requirements of 4.6.3.

5.7.4.4 Criteria

The testing shall demonstrate that the equipment complies with the requirements of IEEE Std 1547 for synchronization parameter limits.

5.8 Interconnection integrity

5.8.1 Protection from electromagnetic interference (EMI) test

5.8.1.1 Purpose

The purpose of these tests is to verify that the EUT's protection from EMI is in compliance with IEEE Std 1547.

5.8.1.2 Procedure

The interconnection equipment of the EUT shall be tested in accordance with IEEE Std C37.90.2 or IEC 61000-4-3 using a signal having a strength of 20 V_{rms}/m prior to modulation. The carrier signal shall reach at least 35 V/m maximum rms field strength after it is modulated with a 1 kHz signal.

Prior to the EMI exposure, three EUT parameter settings shall be made or verified and recorded. During the test procedure(s) described in Clause 6 of IEEE Std C37.90.2-2004, the EUT shall be connected for normal operation and shall be exporting power or it shall be configured such that the EUT is energized and the output circuit(s) can be evaluated in a manner representative of normal operation.

EUTs that include external control circuits, communications ports, metering ports or measurement ports shall be connected in accordance with the EUT installation instructions. Units with external logging shall be set to the fastest available metering frequency.

5.8.1.3 Criteria

The influence of EMI shall not result in a change in state or misoperation of the interconnection functions of the EUT. Misoperation includes but is not limited to temporary or permanent freezing of state, disconnection from the EPS, or change in output power exceeding $1.5 \times \text{MRA}$. The three parameter settings made or verified prior to the EMI exposure shall not change following the EMI exposure.

5.8.2 Surge withstand performance test

5.8.2.1 Purpose

Surges on the EPS power circuits and communications circuits may negatively affect DER operations. The purpose of this test is to verify the level of surge withstand protection specified by the manufacturer of the EUT. The EUT shall be tested to verify the level of surge withstand protection as specified by the manufacturer and in accordance with either or both of the following standards as defined by the manufacturer: IEEE Std C62.41.2 and/or IEEE Std C37.90.1. If the EUT's instructions require specific external surge suppression as part of the installation, the EUT shall be tested with the specified surge protection installed.

5.8.2.2 Procedure

The manufacturer shall specify the location category and exposure level of the tests required by IEEE Std C62.41.2 and/or IEEE Std C37.90.1. The following tests are to be applied for the manufacturer specified levels:

- a) Prior to the surge exposure, three parameter settings shall be made or verified and recorded.
- b) Apply the test procedure in accordance with IEEE Std C37.90.1 to test EUT external communication, signal and control circuits. This excludes optical communication and ports that are only accessible to a service person and that are only used during attended onsite service work.
- c) Apply the test procedure in accordance IEEE Std C62.41.2 and IEEE Std C62.45 to the EUT power circuits.

The EUT shall be tested in all normal operating modes in accordance with IEEE Std C62.45 for equipment rated less than or equal to 1000 V to confirm that the surge withstand capability is met by using the selected test level(s) from IEEE Std C62.41.2. The test should be conducted while the

EUT is operating under nominal or reduced power levels. Alternatively, the EUT may be configured to simulate the condition of exporting so the surge is applied to the EUT components and circuits that are exposed during normal operation. Equipment rated greater than 1000 V shall be tested in accordance with the applicable standards as designated by the manufacturer or system integrator.

- d) If an overcurrent protective device opens as a result of a surge, the protective device shall be reset or replaced prior to the next surge iteration.

Exception: EUTs with non-user or -operator replaceable fuses shall be allowed to have that fuse bypassed to avoid interruption of the test. If a non-replaceable fuse opens and cannot be bypassed to continue the test, that shall be considered evidence of non-compliance.

- e) If the EUT trips offline as a result of the surge, the EUT is required to come back online and return to service, prior to subjecting it to the next surge iteration.

Exception: If the EUT detects an abnormal condition directly related to the surge event and subsequently enters a protected state, it is permitted for the EUT to require a cycling of power or other manufacturer-defined action to reset the EUT and return to normal operation. If the EUT does not come back online and operate normally following the cycling of power or manufacturer-defined reset, the results shall be considered evidence of non-compliance.

5.8.2.3 Criteria

The results of these tests shall indicate that following the surge, the interconnection functions of the EUT did not fail, did not misoperate, and did not provide misinformation.

Misoperation includes but is not limited to disconnection from the EPS [subject to the exceptions in steps d) and e)] and temporary or permanent freezing of state.

The EUT is permitted to trip offline as a result of the surge event. The EUT is considered in compliance if it can reconnect and operate normally after the surge event and after the overcurrent protection device is replaced or reset or an action listed in the Exception under step e) is taken.

The three parameter settings made or verified prior to the surge exposure shall not change.

Misinformation includes, but is not limited to, change in display information or image, discontinued normal operation of the display, errors in the displayed information, loss of normal communications, errors in communicated information, and temporary or permanent freezing of state.

5.8.3 Paralleling device tests

This test is applied to non-semiconductor switching devices that parallel an EUT with the EPS. The following test is for EUTs that operate at 1000 V or less. EUTs that use semiconductor *paralleling devices* rated for 220% of the rated EPS voltage are exempt from this test. For systems over 1000 V, the EUT shall be tested in accordance with the power frequency dielectric withstand rating specified in Table 6 of IEEE Std C37.04-2018 or Table 2 of IEEE Std C37.60-2012 and the procedures specified in subclause 7.3.7.2 of IEEE Std C37.100.1-2018 for dry conditions only. Generator circuit breakers are covered by IEC/IEEE 62271-37-013.

5.8.3.1 Purpose

This test is intended to validate that the *paralleling device* of the EUT is able to withstand a voltage of 1000 V plus two times the 110% upper limit of nominal operating voltage.

5.8.3.2 Procedure

The unit shall be connected to a power supply capable of providing a 60 Hz rms ac voltage potential of 220% of nominal EPS voltage plus 1000 Vac across the DER and EPS paralleling terminals. Voltage shall be increased from zero until the required test level is reached and shall be held at the test voltage for at least 60 s. If the *paralleling device* has already been evaluated and tested to a standard requiring a test at an equal or higher voltage, it shall not be required to be tested again. *Exception:* A dc test voltage of 220% of the nominal ac peak voltage plus 1400 V may be used for the dielectric test.

5.8.3.3 Criteria

Paralleling devices shall comply with the Device Withstand Test in 5.8.3.2 for 60 s without breakdown or flashovers during the test, and there shall be no evidence of damage to the insulation after the test.

5.9 Limitation of dc injection for inverters

5.9.1 Purpose

The purpose of this test is to verify inverter compliance with the dc injection limit specified in IEEE Std 1547, and it is intended for inverters that do not have dc-isolation line-frequency output transformers. The test shall be waived if the DER demonstrates the presence of a dc-isolation line-frequency output transformer, or if the installation instructions specify that the DER is to be connected to the *area EPS* via a dc-isolation line-frequency transformer.

5.9.2 Procedure and data analysis

The procedure and data analysis are as follows:

- a) Operating power levels in this procedure have a tolerance of $\pm 5\%$.
 - 1) Connect the EUT according to the instructions and specifications provided by the manufacturer.
 - 2) Set all source parameters to the nominal operating conditions for the EUT.
 - 3) Set (or verify) all EUT parameters to the nominal operating settings.
 - 4) Record applicable settings.
 - 5) Operate the EUT at 100% of its continuous rated output current and at unity p.f. The EUT shall operate at the specified current and p.f. for the duration of the test.
 - 6) At the EUT output, measure the rms voltage, rms current, and dc component of current on all phases. The averaging window for all measurements shall be not less than one cycle and not more than 60 cycles.
 - 7) Record all measurements at a sampling frequency of not less than the reciprocal of the selected averaging window for a period of 5 min.
- b) For all specified test cases, the following data analysis is required:

- 1) Calculate average values of rms current and voltage on each phase. For each measurement, the average shall include every sample point recorded during the 5 minute test period.
- 2) Verify that the average rms current on each phase is within 5% of the intended value.
- 3) Verify that the average rms voltage on each phase is within 5% of the nominal voltage.
- 4) Calculate average values for the magnitude of the dc component of current on each phase. The average shall be taken of the absolute (unsigned) value of every sample point recorded during the 5 minute test period.
- 5) For each phase, divide the average dc component magnitude value by the rated output current of the EUT and multiply the result by 100. Record the final calculated values as the percent dc injection current for each phase.

5.9.3 Requirements

If an *ac test source* is used for this test, it shall meet the requirements of 4.6.1 and shall have negligible dc offset.

5.9.4 Criteria

The EUT shall be considered in compliance if all calculated percent dc injection currents are within the limit specified in IEEE Std 1547.

5.9.5 Comments

This test may be conducted as part of the current distortion tests.

5.10 Unintentional islanding

5.10.1 General

The unintentional islanding test given in 5.10.2 may be used for any EUT. EUT that use conducted permissive signals for unintentional islanding shall follow the procedure 5.10.3. EUT that have a permissive hardware input shall follow the procedure in 5.10.4. Reverse-power or minimum import power flow protection shall be tested in accordance with 5.10.5. EUT may support multiple methods and shall be tested for each of the methods supported.

The test methods listed in this subclause are some of the methods that are used to provide unintentional islanding protection, but are not exclusively the only methods that are in use or may be used. There are additional methods for unintentional islanding protection that are also used by industry, but type testing those methods is considered out of scope for this standard; such methods include direct transfer trip, radio or cellular communication channels, etc.

The powerline conducted permissive signal test is included in this clause because when an *island* is formed by devices disconnecting from the *area EPS*, the conducted signal is attenuated and loss of signal is an indicator that an *island* has formed.

Full compliance is achieved by meeting the criteria of 5.10.2 or 5.10.5. Partial compliance is achieved by meeting the criteria of 5.10.3 or 5.10.4, because those methods either require additional equipment beyond

what is tested in the *type test* or installed on the EPS. More information can be found in 8.1.2 on treatment of full and partial compliance during *DER evaluation* and commissioning.⁴⁷

In order to facilitate faster test times, default time settings longer than 2.5 seconds may be reduced to as low as 2.5 seconds for the purposes of these tests, and enter service delay settings may be adjusted to any convenient value.

5.10.2 Balanced generation to load unintentional islanding test

5.10.2.1 Purpose

The purpose of this test is to verify that DER cease to energize and trip from the *area EPS* as specified in IEEE Std 1547 when an unintentional island condition is present. A balance between load and generation in both active and reactive powers is necessary for unintentional island testing in this subclause. This test is intended to create such conditions in a controlled environment such that the unintentional islanding protections of the DER may be verified. This test validates unintentional islanding performance on a single EUT operating at combinations of power levels and grid support functions enabled.

When using power hardware-in-the-loop (PHIL) simulation-based testing approach, the procedure as outlined herein with respect to discrete hardware components is to be followed. In unintentional islanding testing using PHIL, the *ac test source*, switch S3, switch S1, and the resonant load bank are part of the simulated subsystem. The simulated subsystem is to be interfaced to the EUT through power amplifiers. Requirements for PHIL test equipment, test setup, and simulated subsystem are given in 5.10.2.3. See Annex F for more on PHIL.

5.10.2.2 Procedure

Figure 7 presents a balanced generation to load unintentional islanding test configuration.

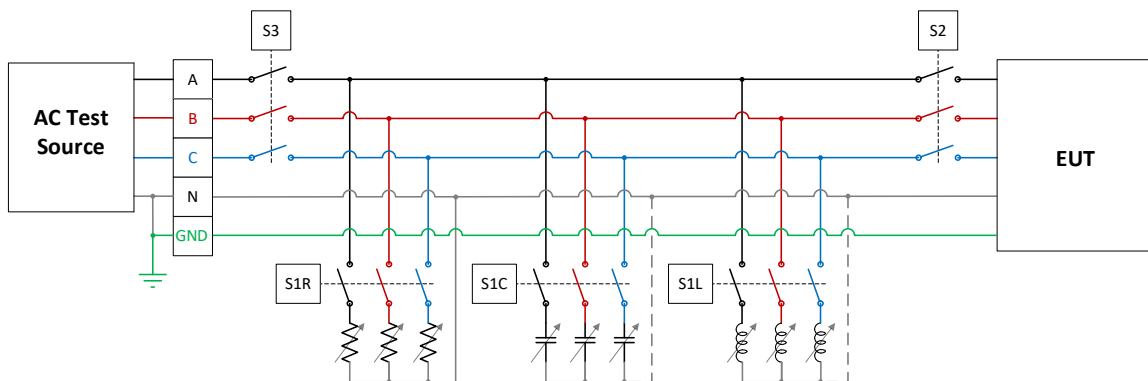

Figure 7—Balanced generation to load unintentional islanding test configuration^{48, 49}

⁴⁷Additional DER integration issues may need to be evaluated for all *island* detection methods, including interactions of combinations of islanding detection methods on the same *area EPS*.

⁴⁸Switches S1R, S1C, S1L may be replaced with individual switches on each of the RLC load components. The adjustable load components may be formed by switching in and out of the circuit discrete component values or use of variable devices, etc., so long as the net adjustability of the load components is achieved.

⁴⁹It is common practice to use electronic simulated photovoltaic (PV) source simulators rather than actual PV inputs.

If the EUT installation instructions allow for any EPS service connections⁵⁰ with a neutral, then the test shall be done with the neutral connected to the resistive load. If the EUT installation instructions only allow for EPS service connections without a neutral, then the neutral need not be connected to the EUT and RLC loads. Connection of neutral to the inductive and capacitive loads is optional, shown by the dotted line in the figure. The *ac test source* for unintentional islanding testing shall include a grounded neutral if any of the EPS service connection types for which the EUT is rated include a grounded neutral.⁵¹ For single-phase systems, the capacitor and inductor loads may be connected line-to-line or line-to-neutral, the resistor load shall be connected from each line to neutral.

- a) Test circuit configuration:
 - 1) The test circuit shall be configured as shown in [Figure 7](#) using only the number of phases required for EUT operation.⁵² The connection of the neutral conductor to the EUT is only required when the EUT has a neutral connection. If the EUT does not have an equipment ground connection, then GND is not required to be connected to the EUT.⁵³ The neutral connection shall be unaffected by the operation of switch S3 or S2. Switches S2 and S3 shall be gang-operated and multi-pole. The grounding of the load and *ac test source* shall be unaffected by the position of switch S3. Switch S2 is not required but is permitted.
 - 2) Connect the EUT according to the instructions and specifications provided by the manufacturer. If the EUT manufacturer requires an external or separate transformer, the transformer is to be included in the test configuration between the EUT and RLC load components.
 - 3) The *ac test source* voltage is set to EUT nominal voltage $\pm 5\%$ and nominal frequency.⁵⁴
- b) EUT settings:
 - 1) Commanded active power operating mode, as described in [Table 12](#), shall be used for UI testing.

Table 12 —EUT active power modes

EUT active-power mode	Description
Tracking	For EUT operating with an input power tracking capability, the input source power is adjusted so that the EUT operates at the desired EUT output power level.
Commanded	In this case, the EUT is set to a commanded active output power level. The input source power shall be set capable of delivering at least 125% active power in case the EUT needs to increase output active power that may occur during these tests. If the EUT is not capable of operating at a specified power level, then it shall be operated at its closest nonzero power level capability.

- 2) These tests shall be run for each of the test cases shown in [Table 13](#) or [Table 14](#), depending upon EUT category. The power levels in the tables are listed on a per unit basis with a tolerance of ± 0.05 p.u. and are listed in the generator frame of reference. The P_{EUT} , Q_{EUT} operating points of the EUT are chosen to be spread out over a range of the active and reactive power capabilities defined in 5.2 of IEEE Std 1547-2018.

Test cases 7A and 8A as well as voltage-active power (VW) functions are not required for Category A equipment shown in [Table 13](#). However, if the EUT does support those functions then they shall be included in the unintentional islanding testing.

⁵⁰ Area EPS service at the PCC.

⁵¹ Not all EPS service connections include a grounded neutral.

⁵² For example, a split phase 120/240 residential DER may be tested using phase A as Line1 and phase B as Line2, and phase C is not used. A single phase-to-neutral is also permissible, for a 120 or 277 phase-neutral configuration.

⁵³ Some EUT are in double insulated plastic enclosures and do not have or require a ground connection.

⁵⁴ A wider voltage tolerance is allowed so that testing may be done from a *local EPS*.

Table 13—Balanced load unintentional islanding test matrix for Category A

Test case	EUT power level (p.u.) ^a		Reactive power mode		Active power mode settings		Initial RLC load (p.u.) ^a			Effective quality factor ^b
	P_{EUT}	Q_{EUT}	Mode and setting	Response time (s)	VW	FW	$P_R+P_L+P_C$	Q_C	Q_L	
1A	1.00	0.00	Constant power factor	p.f. = 1.00	n/a	Default	-1.00	1.00	-1.00	1.00
2A	0.50	0.00				Default	-0.50	0.50	-0.50	1.00
3A	0.90	-0.25	Constant power factor	p.f. = -0.96	n/a	LA	-0.90	0.90	-0.65	1.00
4A	0.90	0.44		p.f. = 0.90			-0.90	0.46	-0.90	1.00
5A	1.00	0.00	Voltage-reactive power	MA	1		-1.00	1.00	-1.00	1.00
6A	0.50	0.00		Default	10		-0.50	0.50	-0.50	1.00
7A	0.50	0.00	Active power-reactive power	Default	n/a	MA	-0.50	0.50	-0.50	1.00
8A	1.00	0.00		MA			-1.00	1.00	-1.00	1.00
9A	0.90	-0.25	Constant reactive power	$Q = -0.25$	n/a		-0.90	0.90	-0.65	1.00
10A	0.50	0.44		$Q = 0.44$			-0.50	0.06	-0.50	1.00

NOTE—LA = least aggressive; MA = most aggressive. As indicated in Table 16 through Table 19.

^a (p.u.) is per unit of the EUT kVA rating.

^b Effective quality factor is provided for information only to help readers compare these test requirements with earlier versions of this standard. See Annex D for details.

Table 14—Balanced load unintentional islanding test matrix for Category B

Test case	EUT power level (p.u.) ^a		Reactive power mode		Active power mode settings		Initial RLC load (p.u.) ^a			Effective quality factor ^b
	P_{EUT}	Q_{EUT}	Mode and setting	Response time (s)	VW	FW	$P_R+P_L+P_C$	Q_C	Q_L	
1B	1.00	0.00	Constant power factor	p.f. = 1.00	n/a	Default	Default	1.00	1.00	1.00
2B	0.50	0.00						0.50	-0.50	1.00
3B	0.90	-0.44	Constant power factor	p.f. = -0.90	n/a	Off	LA	0.90	-0.46	1.00
4B	0.90	0.44		p.f. = 0.90				-0.90	-0.90	1.00
5B	1.00	0.00	Voltage-reactive power	MA	1	MA	MA	1.00	-1.00	1.00
6B	0.50	0.00		Default	10			-0.50	-0.50	1.00
7B	0.50	0.00	Active power-reactive power	Default	n/a			-0.50	0.50	1.00
8B	1.00	0.00		MA				-1.00	-1.00	1.00
9B	0.50	-0.44	Constant reactive power	$Q = -0.44$	n/a			-0.50	0.50	1.00
10B	0.50	0.44		$Q = 0.44$				-0.50	0.06	1.00

NOTE—LA = least aggressive; MA = most aggressive, as indicated in Table 16 through Table 19.

^a (p.u.) is per unit of the EUT KVA rating.

^b Effective quality factor is provided for information only to help readers compare these test requirements with earlier versions of this standard. See Annex D for details.

For EUT with ratings less than the P_{EUT} settings in Table 13 or Table 14, the EUT may be tested at their rated value, and RLC loads adjusted accordingly to maintain the same target effective quality factor. In Table 13 or Table 14, the active power loss of the RLC load components is combined in the “ $P_R+P_L+P_C$ ” column. Inductive load typically has a significant active power loss component and the resistive load must be adjusted so that the total active power loss of the RLC loads match the active power generation of the EUT. For EUTs that cannot meet the P_{EUT} power levels in Table 13 or Table 14, it is acceptable to operate at the closest power level at which the EUT is capable of operating.⁵⁵

Table 15 shows the voltage and frequency trip levels and *clearing time* settings to be used for the unintentional islanding tests. If the EUT is capable of operating at wider voltage and frequency trip settings, then such settings shall be used. The EUT may have additional voltage and frequency trip settings for self-protection, and such settings may remain enabled in the EUT.

Table 15—Voltage and frequency trip settings for unintentional islanding testing⁵⁶

Trip function	Category I and Category II		Category III	
	Voltage (p.u.)	Clearing time (s)	Voltage (p.u.)	Clearing time (s)
OV2	1.2	0.16	1.2	0.16
OV1	1.2	13	1.2	13
UV1	0	21	0	50
UV2	0	2	0	21
	Frequency (Hz)	Clearing time (s)	Frequency (Hz)	Clearing time (s)
OF2	66	1000	66	1000
OF1	66	1000	66	1000
UF1	50	1000	50	1000
UF2	50	1000	50	1000

Table 16 shows the most aggressive settings for the voltage–active power function to be used in these tests. The P_2 setting is intentionally set to a low but nonzero value so that the tester can differentiate between when the unit stops operating due to unintentional islanding operation versus power being reduced to zero due to this function response. Testing of a storage system configured with these settings is applicable to this *type test*.

⁵⁵For example, rotating machines typically have an active power rating that is less than their apparent power rating, 0.9x or 0.8x.

⁵⁶These settings are set to magnitude levels furthest from nominal and with the longest *clearing times* based on the ranges of allowable settings in IEEE Std 1547 so these settings do not impact unintentional islanding *clearing times*.

Table 16—Voltage–active power (VW) settings for unintentional islanding testing

Setting	Most aggressive	Default
	Voltage (p.u.)	
V_1	1.05	1.06
V_2	1.06	1.10
Active power (p.u.)		
P_1	1.0	1.0
P_2	0.2	0.2
Response time (s)		
Open Loop Response Time	0.5	10

Table 17 shows the settings for the voltage–reactive power function to be used in these tests. The autonomously adjusted reference voltage (V_{Ref}) capability of the DER is not enabled for this testing since the fastest time constant is 300 s, far longer than any response that would affect unintentional islanding operation. The values in this table are for $V_{Ref} = 1.00$ p.u. V_{Ref} may be adjusted during the power balance setup of the test, as needed, so that the testing is started in the center of the VV curve. If the EUT has a wider range of capability than the settings in Table 17, such wider settings may be used.

Table 17—Voltage–reactive power (VV) settings for unintentional islanding testing

Setting	Category A		Category B	
	Most aggressive	Default	Most aggressive	Default
	Voltage (p.u.)			
V_1	0.98	0.9	0.98	0.92
V_2	1	1	1	0.98
V_3	1	1	1	1.02
V_4	1.02	1.1	1.02	1.08
Reactive power (p.u.)				
Q_1	0.25	0.25	0.44	0.44
Q_2	0	0	0	0
Q_3	0	0	0	0
Q_4	−0.25	−0.25	−0.44	−0.44
Response time (s)				
Open Loop Response Time	1	10	1	5

Table 18 shows the settings for the active power-reactive power function to be used in these tests.

Table 18—Active power-reactive power settings for unintentional islanding testing

Setting	Category A		Category B	
	Most aggressive	Default	Most aggressive	Default
	Active power (p.u.)			
P_1	0.2	0.2	0.2	0.2
P_2	0.8	0.5	0.9	0.5
P_3	0.9	1	1.0	1
Reactive power (p.u.)				
Q_1	0.44	0	0.44	0
Q_2	0.44	0	0.44	0
Q_3	-0.25	-0.25	-0.44	-0.44

Table 19 shows the settings for the frequency-droop function to be used in these tests. Least aggressive, default, and most aggressive settings are used in the test matrix in Table 13 and Table 14.

Table 19—Frequency-droop (FW) settings for unintentional islanding testing

Setting	Category I and Category II			Category III		
	Least aggressive	Default	Most aggressive	Least aggressive	Default	Most aggressive
db_{OF}, db_{UF}	1.0	0.036	0.017	1.0	0.036	0.017
k_{OF}, k_{UF}	0.05	0.05	0.03	0.05	0.05	0.02
$T_{response}$ (s)	10	5	1	10	5	0.2

- c) Establish a balanced load condition for each test case.

Operate the EUT and adjust the RLC load components so that active, P_{S3} , and reactive, Q_{S3} , power flow through each phase measured at switch S3 is less than 2% of the EUT rated power on a steady-state basis. Initial settings of the EUT and RLC load components for each test case are shown in Table 13 and Table 14. These settings are sufficient to get close to the balanced power requirement, and the EUT settings are not further adjusted. The RLC load components are then adjusted to achieve a balance between generation and load active and reactive powers such that the following two conditions are met:

$$|P_{S3}| = |P_{EUT} + P_R + P_C + P_L| \leq 0.02 \text{ p.u.}$$

$$|Q_{S3}| = |Q_{EUT} + Q_R + Q_C + Q_L| \leq 0.02 \text{ p.u.}$$

Multiphase voltages shall be balanced to within 5% of each other.

AC test source voltage and/or frequency and EUT power may be adjusted to meet the power balance requirements so long as the resulting EUT power levels remain within 0.05 p.u. of the values in Table 13 or Table 14. The order in which adjustments are made is not specified in this procedure.

- d) Verify the test setup can sustain an *island*.
- 1) Disable the unintentional islanding protection in the EUT.
 - 2) Operate the EUT and RLC load under the conditions established in step c) for any one of the test cases in Table 13 or Table 14 as appropriate for the EUT Category.
 - 3) With the EUT and load operating at stable conditions, record the voltage and current at switch S3. Record the active and reactive power at switch S3, switch S2, the resistive load, the capacitive load and the inductive load on a net and per phase basis.
 - 4) Open switch S3. If, after 10 s, the *island* circuit remains energized, the test setup is considered verified. Measure and record the voltage and frequency of the islanding operation.
 - 5) De-energize the *island*.
 - 6) Enable the unintentional islanding protection in the EUT.
- e) *Clearing time* tests.
- 1) Operate the EUT and load under the conditions established in step c) for each one of the test cases in Table 13 or Table 14 as appropriate for the EUT Category.
 - 2) With the EUT and load operating at stable conditions, record the voltage and current at switch S3. Record the active and reactive power at switch S3 on a net and per phase basis.⁵⁷ Record the active and reactive power of the EUT, the resistive load, the capacitive load and the inductive loads on a net and per phase basis as well. These measurements may be done individually for the EUT, resistive load, capacitive load and inductive loads prior to operating the entire combined circuit.
 - 3) Open switch S3 and measure the time it takes for the EUT to cease to energize the *island*. This is the time from when S3 opens to when instantaneous voltage and EUT current in the *island* drops and remains below 0.05 p.u.⁵⁸ Record this as the *clearing time*.
 - 4) The test is to be repeated with the reactive load (either capacitive or inductive) adjusted in 1% increments from 95% to 105% of the initial balanced load value determined in step c). If *clearing times* are still increasing at the 95% or 105% points, additional 1% increments shall be taken until *clearing times* begin decreasing.

If at any point at least three test instances show *island* frequency increasing above the fundamental frequency of the *ac test source* after S3 was opened and at least three instances show *island* frequency decreasing below the fundamental frequency of the *ac test source* after S3 was opened S3 was opened, the remaining 1% steps and step e)5) may be omitted.⁵⁹

- 5) After reviewing the results of the previous step, the 1% setting increments that yielded the three longest *clearing times* shall be subjected to two additional test iterations. If the three longest *clearing times* occur at nonconsecutive 1% load setting increments, the additional two iterations shall be run for all load settings in between.

⁵⁷It is typically necessary to make measurements on a fundamental frequency basis in order for the power balance requirements to be met. This may occur when high harmonic or rms currents or voltages are present in the system.

⁵⁸One method of determining when S3 opens is to monitor an auxiliary contact from S3. Another method is to monitor the current waveform through S3, this can be effective when there are harmonic or nonzero currents other than at fundamental frequency.

⁵⁹Having test cases that show frequency drift above and below the initial frequency indicate that the testing has spanned the frequency balance point where islanding would most likely occur; thus, further testing is not needed.

5.10.2.3 Requirements

Clearing time for each test instance shall be recorded.

Each phase voltage shall be within 5% of rated voltage prior to each test.⁶⁰

The *ac test source* voltage THD shall be less than or equal to 5% and the individual harmonics less than or equal to 3%. The *ac test source* conditions shall be documented as used for testing. The EUT manufacturer and test agency shall mutually identify the *ac test source* voltage or harmonics that adversely affect islanding detection and identify this worst-case condition, within the *ac test source* limits.

Active, P_{S3} , and reactive, Q_{S3} , power flow through each phase measured at switch S3 shall be less than 0.02 p.u. of the EUT per-phase rated power on a steady-state basis for each test case in step c).⁶¹

Active and reactive power measurements shall be the fundamental frequency component.

EUT active, P_{EUT} , and reactive, Q_{EUT} , power measurements shall be within 0.05 p.u. of the values in Table 13 or Table 14 for each test case in step c).

Reactive power measurements of the capacitive, Q_C , and inductive, Q_L , loads shall be within 0.05 p.u. of the values in Table 13 or Table 14 for each test case in step c).

The test and measurement equipment shall record each phase-to-neutral or phase-to-phase voltage, as appropriate, over the duration of the test at the output of the EUT. The DER clearing time is determined from the time S3 is opened until the time the instantaneous voltage and EUT current drops and remains below 0.05 p.u.⁶²

The resistive and inductive load components shall not exceed a current TRD of 5% prior to opening switch S3.

If the EUT has adjustable unintentional islanding clearing time settings, the maximum and minimum clearing time settings shall be tested.⁶³

A power hardware-in-the-loop (power HIL, or PHIL) simulation-based approach may be used if test equipment and setup characteristics meet the following requirements, which are in addition to the general requirements stated and unintentional islanding testing requirements above. Additional information on HIL and terminology used herein can be found in Annex F.

- a) The real-time simulated subsystems including the RLC-load bank, rest-of-system (ROS), and interface algorithm (IA) shall use an electromagnetic transient-type simulation approach and use instantaneous voltages and currents. A simulation time step of 50 μ s or smaller shall be used. The simulated inductor shall have a ratio of reactance to resistance of at least 20, and the inductor series resistance shall have a non-zero value.
- b) The PHIL simulation capabilities shall be tested to verify the simulated circuit behavior. This requirement has to be tested once per EUT by achieving the test points described in the following and considering the minimum accuracy requirements as stated in IEEE Std 1547. This test shall start at the EUT's nominal conditions and unintentional islanding detection disabled. The EUT

⁶⁰This provides both a balanced and near-nominal voltage condition for the ac connection to the EUT.

⁶¹Certain anti-islanding algorithms sufficiently perturb the fundamental frequency current or power through switch S3 so that the 2% limit cannot be achieved on a per cycle basis. Averaging of the rms current or power over a number of cycles in a manner that captures the average magnitude may be utilized.

⁶²In some cases, an auxiliary contact on S3 is the best method; in other cases, examination of the high-frequency currents measured at S3 are an effective means to determining when S3 opens. Either method is acceptable.

⁶³Such as to meet the conditional extended *clearing time* allowance in IEEE Std 1547.

shall be operated at nominal power conditions with a p.f. of one. Other regulation functions shall be deactivated. By adjusting the real-time simulated RLC-load bank settings, the four off-nominal conditions numbered 1) through 4) below shall be used in validating the simulated circuit behavior. The four test points are based on deviations from nominal voltage conditions, i.e., voltage magnitude and frequency. The EUT's active power and reactive power are kept at their respective values.

Starting at nominal voltage magnitude and frequency conditions, the R-, L-, and C-settings shall be adjusted to move the operating point to the following four conditions, the real-time simulated switch S3 opened, and the *island* observed for 10 seconds. The four test conditions may be combined into a single test or performed individually. The EUT set-point shall not be changed throughout this test.

- 1) voltage = 0.90 p.u. and frequency = 58.7 Hz;
- 2) voltage = 0.90 p.u. and frequency = 61.0 Hz;
- 3) voltage = 1.05 p.u. and frequency = 58.7 Hz; and
- 4) voltage = 1.05 p.u. and frequency = 61.0 Hz

where the voltage target is ± 0.02 p.u. and the frequency ± 0.1 Hz. The R-, L-, and C-settings used to achieve the four operating conditions shall be recorded.

- c) The PHIL simulation setup shall be capable of open-circuit voltage harmonic synthesis at the PHIL-amplifier terminals of at least 800 Hz and up to a frequency that is twice the unintentional islanding control bandwidth of the EUT. If information on the control bandwidth is not available, the upper frequency capabilities shall be at least 1.5 kHz. This conformance test is to be performed and documented for the PHIL test facility once at the lowest and highest nominal voltage levels at which the PHIL setup will be used.⁶⁴ The voltage harmonic frequency test points shall follow a logarithmic scale starting at five times the fundamental frequency with at least five data points per decade. The voltage harmonic magnitude shall be at least 1% of the nominal voltage while operating as a standalone voltage source.
- d) As an alternative to the requirement given in item c) above, an impedance measurement approach may be used to evaluate ROS real-time simulation capabilities at the two voltage levels.⁶⁵ In the following test, the measured impedance characteristics shall reflect the expected RLC behavior within the magnitude and angle requirements as given below and measured from $f_{LL} = 20$ Hz to $f_{UL} = 1.5$ kHz or up to twice the EUT's unintentional islanding control bandwidth. The evaluation of the PHIL setup shall be conducted with the ROS simulating the RLC load bank with nominal EUT-derived values. The EUT with unintentional islanding algorithm disabled or any other appropriately rated and controllable source may be used. The EUT or source shall establish the nominal power flow conditions with respect to voltage magnitude, frequency, active power flow, and a p.f. of one. Using a dedicated impedance measurement unit or the PHIL-setup, the ROS-impedance as seen from the terminals of the EUT shall be determined. At least five data points per decade shall be collected with the frequency data points following a logarithmic scale. The magnitude and phase requirements are as follows:

- 1) Magnitude requirement: for $f_{LL} \leq f \leq f_{UL}$ the impedance magnitude $|Z|$ shall be within a magnitude range $|\Delta Z|$ about the simulated RLC-load with

$$|\Delta Z| = \max(2.5\%, 2.5\% + (f - 60 \text{ Hz}) / f_{UL} \times 30\%)$$

- 2) Phase requirement: for $f_{LL} \leq f \leq f_{UL}$ the impedance phase $\angle(Z)$ shall be within a phase range $\angle(\Delta Z)$ of the simulated RLC-load bank with

⁶⁴These tests need to be performed for every PHIL test setup variation including variations in interfacing with the EUT, for example, interface transformers to match PHIL- and EUT-voltage levels.

⁶⁵These tests need to be performed for every PHIL test setup variation including variations in interfacing with the EUT, for example, interface transformers to match PHIL- and EUT-voltage levels.

$$\angle(\Delta Z) = \max(4^\circ, 4 + (f - 60 \text{ Hz}) / f_{UL} \times 41^\circ)$$

- e) The PHIL simulation setup shall be capable of recording waveform captures with real-time simulated switch S3 status and of the voltage across the real-time simulated RLC circuit and measured voltage at the EUT terminals to allow measurement of delays or phase shift between the two. The following test is used to record this characteristic. Set the simulated RLC parameters to Test Case 1B of Table 14 with the EUT disabled. Open simulated switch S3 and record the voltage across the simulated RLC and the voltage measured at the EUT terminals. For multi-phase systems, select one phase for measurement. Measure the time delay for five voltage zero-crossings before switch S3 opens and one voltage zero-crossing after switch S3 opens. The average of these six measurements shall be less than 200 microseconds.⁶⁶

5.10.2.4 Criteria

Each recorded clearing time shall be less than the unintentional islanding clearing time requirement of 8.1 of IEEE Std 1547-2018.

5.10.2.5 Comments

Power electronic RLC loads may be used if verification as mentioned in 5.10.2.3 indicates the simulated loads emulate discrete component RLC load characteristics. This is allowed at the discretion of the *testing agency* (e.g., the Nationally Recognized Testing Laboratory, in many cases).

Transformers and autotransformers may be used as part of the RLC load circuit. Active and reactive power consumption of such devices is to be considered part of the inductive load (P_L and Q_L).

5.10.3 Powerline conducted permissive signal test

5.10.3.1 Overview

A conducted permissive signal is a signal conducted on the powerline that provides permission for the DER to operate. Loss of the permissive signal, due to discontinuity of the powerline, must be detected by the DER and cause the DER to cease to energize and trip, or disconnect, from the *area EPS* within the unintentional islanding clearing time requirement of 8.1 in IEEE Std 1547-2018.

5.10.3.2 Purpose

This test validates UI performance of a single EUT with the presence of a permissive signal that allows the operation of the EUT. This test evaluates the EUT's unintentional islanding permissive signal detection and determines the responsiveness of the EUT when the permissive signal is attenuated. This test measures the EUT's response time from detection of the UI condition until the EUT ceases to energize and trips from the *area EPS*. The permissive signal is independent of operating conditions of the EUT; therefore, this test is not done at combinations of power levels or grid support functions.

⁶⁶This time delay limit is based on keeping the difference in PHIL real-time simulated circuit and EUT reactive power below 7.5%.

5.10.3.3 Procedure

The test diagram is shown in [Figure 8](#). The test configuration uses an EUT that is connected to an *ac test source*. A gang-operated switch, SP, and attenuator is used to simulate a circuit breaker or disconnect device (such as a midline recloser, sectionalizer, or disconnect switch). A permissive signal, P, is injected using a signal generator at the *ac test source*.

Under normal grid conditions the attenuator shall be set according to manufacturer's specified instructions and the permissive signal shall be present at the EUT's terminals. The EUT shall not trip while SP is closed. The opening of the SP switch blocks the permissive signal from reaching the EUT. The EUT should detect the loss of the permissive signal, and cease to energize and trip. The time between the opening of the switch and the trip response of the EUT shall be recorded.

The EUT shall disable operation as long as the SP switch is open. The EUT shall remain in a cease to energize and trip state. Closing of the SP switch following a trip state will restore the presence of the permissive signal at the EUT terminals. Upon restoration of the permissive signal, the EUT shall re-enable operation, allowing it to reconnect to the grid using methods in 4.10 of IEEE Std 1547-2018.

A permissive signal detector that can detect presence or lack-of-presence of the permissive signal is integrated as an interface of the EUT or placed in front of it as an add-on accessory.

The presence of the permissive signal shall be defined as an ON level and the lack-of-presence or loss-of-signal shall be defined as an OFF level. The ON and OFF signal strength levels are recorded as part of the test.

Where the EUT manufacturer requires an external or separate transformer, the transformer is to be connected between the EUT and the *ac test source*.

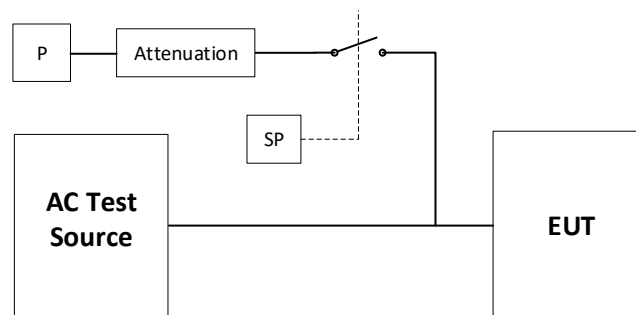

Figure 8—Permissive signal unintentional islanding test configuration

- a) The test circuit shall be configured as shown in [Figure 8](#), using only the number of phases required for EUT operation. The neutral connection (grounded conductor) as well as all current carrying conductors and the *ac test source* shall be unaffected by the operation of the permissive signal switches. The permissive signal switch shall be gang operated.
- b) Connect the EUT according to the instructions and specifications provided by the manufacturer.
- c) Set (or verify) all EUT parameters to the default settings in IEEE Std 1547-2018. Any test condition shown in [Table 13](#) or [Table 14](#) may be selected for these tests.
- d) Set the *ac test source* to the EUT nominal voltage $\pm 5\%$ and frequency.
- e) Record all applicable settings.
- f) Close switch SP and set the attenuator according to manufacturer instructions. Wait for the EUT to Enter Service.

IS 18969 : 2024

- g) Record the signal level of the received permissive signal as the ON level.
- h) Set the attenuation, according to manufacturer instructions, to a level that causes the EUT to cease to energize and trip.
- i) Record the signal level of the received permissive signal as the OFF level.
- j) Adjust the attenuator back to the setting that produces the ON level. Wait for the EUT to Enter Service.
- k) Open gang-operated permissive signal switch, SP, and record the time between the opening of the permissive switch and when the EUT ceases to energize and trips.
- l) Close the gang-operated permissive signal switch, SP, and verify EUT Enters Service.
- m) Repeat steps d) through l) for a total of 4 times.

5.10.3.4 Requirements

The EUT may be operated under any test condition in [Table 13](#) or [Table 14](#) and have continuous connection to the *ac test source*.

The test and measurement equipment shall record each phase current and each phase-to-neutral or phase-to-phase voltage, as appropriate, to determine fundamental frequency real and reactive power flow over the duration of the test at the output of the EUT.

The DER clearing time is determined from the time SP is opened until the time voltage and current drop and remains below 0.05 p.u.

Powerline permissive signal levels shall be recorded for the operate (ON) and non-operate (OFF) states of the EUT. This data shall be recorded and available for EPS operators.

5.10.3.5 Criteria

A test is successful when the DER ceases to energize and trips within the clearing time specified in IEEE Std 1547 after permissive signal is interrupted.

If the EUT has adjustable permissive signal detection *clearing times*, it shall be verified that the EUT detects and trips at the minimum and maximum adjustable *clearing time*.

The actual cease-to-energize and clearing time for each test shall be recorded.

A single failure of any of these tests is considered a failure of the entire test sequence.

5.10.3.6 Comments

The maximum recorded *clearing times* and the ON and OFF signal thresholds shall be presented with other EUT literature.

After the loss of the permissive signal, there is no provision that allows the EUT to re-energize the *area EPS* once the required delay time has elapsed and the voltage and frequency at the EUT PoC is within operating ranges.

Compliance with this *type test* alone only provides partial unintentional islanding compliance.⁶⁷ Determination of full compliance shall be achieved during the *DER evaluation*.

5.10.4 Permissive hardware-input test

This test is provided for EUT that have a hardware input that controls whether the EUT is permitted to operate (or tripped and not tripped, or ceased to energize, and so forth).⁶⁸ Separate equipment that detects an unintentional island condition and generates the input signal is not part of this *type test*.⁶⁹

5.10.4.1 Purpose

This test verifies proper operation and *clearing time* of EUT to permissive signal hardware inputs.

5.10.4.2 Procedure

The procedure is as follows:

- a) Default settings in IEEE Std 1547-2018 DER shall be used. To facilitate faster test times, the following settings may be used in lieu of default values:⁷⁰
 - 1) *ES*⁷¹ *Delay time* may be programmed to 10 s or more.
 - 2) *ES Ramp Rate* may be set to 1 s.
 - 3) *ES Randomized Delay* may be set to 1 s.
- b) Set the hardware input to the permissive operate state.
- c) Close the *ac test source* connection to the EUT.
- d) Operate the EUT per the manufacturer's instructions at any active power level that the unit can sustain and that can be reliably detected for feeding active power to the *ac test source*.
- e) Set the hardware input to the non-permissive operate state.⁷²
- f) Measure the *clearing time* from when the hardware input was set to the non-permissive state to when the EUT ceases to energize and trips.
- g) Record the *clearing time*.
- h) Wait for at least ten percent over the *ES Delay time* setting + *ES Randomized Delay* time setting.
- i) Open the *ac test source* connection to the EUT.
- j) Wait for at least ten percent over the *ES Delay time* setting + *ES Randomized Delay* time setting
- k) Close the *ac test source* connection to the EUT.
- l) Wait for at least ten percent over the *ES Delay time* setting + *ES Randomized Delay* time setting.
- m) Set the hardware input to the permissive operate state.
- n) Monitor the EUT to verify that it now Enters Service.
- o) Repeat this test sequence for a total of three times.

⁶⁷Combination with other equipment or methods is needed in order to achieve full compliance, such as an EPS operator provided permissive signal.

⁶⁸The intent is for hardware input, contact closure, TTL signal, or other hardware means. This is not the same as the permit service function tested in Enter Service test, 5.6.

⁶⁹Such equipment might be direct transfer trip or conducted permissive signal equipment.

⁷⁰Table 39 of IEEE Std 1547-2018 provides definitions of the Enter service after trip parameters.

⁷¹Enter Service

⁷²Monitor the DER for any attempts to enter service while in the non-permissive operate state.

5.10.4.3 Requirements

Document the hardware input type and states for permissive and non-permissive operate states.⁷³

5.10.4.4 Criteria

The EUT is considered to comply with these requirements if there is no recorded *clearing time* that exceeds the unintentional islanding *clearing time* requirements of 8.1 of IEEE Std 1547-2018, and there is no attempt by the EUT to Enter Service while the hardware input is in the non-permissive state.

5.10.4.5 Comments

The longest *clearing time* measured during this test shall be reported in the test results.

Compliance with this *type test* alone only provides partial unintentional islanding compliance.⁷⁴ Determination of full compliance shall be achieved during the *DER evaluation*.

During *DER evaluation*, the *clearing time* reported from this *type test* is to include the unintentional islanding *detection time* of the equipment connecting to this hardware input in order for the *DER system* to provide full unintentional islanding compliance.

5.10.5 Reverse or minimum import active-power flow

5.10.5.1 General

IEEE Std 1547 requires *DER units* to cease to energize the *area EPS* during unintentional islanding conditions. One of the ways in which this requirement may be met is with reverse or minimum import active-power flow protection. The DER installation may contain reverse or minimum import active-power flow protection, sensed between the *point of DER connection* and the PCC, which disconnects or isolates the DER if power flow from the *area EPS* to the *local EPS* falls below a set threshold or reverses.

5.10.5.2 Magnitude test

5.10.5.2.1 Purpose

This test is performed to verify the reverse or minimum import active-power function trips the EUT within the MRA of the minimum import active-power setting of the EUT. For reverse power flow, the setting would be a negative value. For minimum import active-power flow, the setting would be a positive value. The reverse or minimum import active-power accuracy of the EUT shall be specified prior to beginning the tests.

⁷³For example, an input type may be contact closure, and closed defines the permissive operate state and open defines the non-permissive operate state.

⁷⁴Combination with other equipment or methods is needed in order to achieve full compliance, such as an EPS operator provided DTT.

5.10.5.2.2 Procedure

The procedure is as follows:

- a) Connect EUT according to the instructions and specifications provided by the manufacturer.
- b) Set the *ac test source* voltage to nominal, and set the EUT reactive current to the required injection capabilities of Table 7 of IEEE Std 1547-2018.
- c) Set (or verify) all EUT parameters to the nominal operating settings, this includes the minimum import active-power setting (refer to A.5 for additional detail).
- d) Record applicable settings.
- e) Referring to the reverse or minimum import active-power magnitude test described in Annex A, adjust the active current to starting point *I_b*. The active current shall be held at this value for period *t_h*.⁷⁵ At the end of this period, initiate the active current ramp function.
- f) Record the active current and power value when the EUT trips.⁷⁶
- g) Return the active current to nominal value *I_N* (and reset the EUT as necessary).
- h) Repeat steps c) through g) four times for a total of five tests.
- i) Repeat steps b) through h) at the required absorption capabilities of Table 7 of IEEE Std 1547-2018.
- j) For EUTs that have a range of adjustable minimum import active-power settings, repeat steps c) through i) at the minimum and maximum minimum import active-power settings.
- k) For *multiphase* systems that control each phase individually, repeat steps e) through h) for each phase individually and all phases simultaneously.

5.10.5.2.3 Requirements

The reverse or minimum import active power setting of the EUT shall be specified for each of these tests.

5.10.5.2.4 Criteria

The EUT shall be considered in compliance if it ceases to energize the *ac test source* and trips within the MRA of each minimum import active-power setting for active power during all tests.

5.10.5.3 Time test

5.10.5.3.1 Purpose

This test is performed to characterize the accuracy of the reverse or minimum import active-power *clearing time* setting setting(s) of the EUT. The reverse or minimum import active-power protection *clearing time* accuracy of the EUT shall be specified prior to beginning the tests.

5.10.5.3.2 Procedure

The procedure is as follows:

- a) Connect the EUT according to the instructions and specifications provided by the manufacturer.

⁷⁵The variable *t_h* is at least two times the *clearing time* setting. This number may be adjusted to avoid conflict with other trip points.

⁷⁶Because the source voltage is 1.0 per unit and the phase relationship between the source voltage and current is 180°, the reverse-power trip magnitude will be directly proportional to the current magnitude at the trip point.

- b) Set the source and DER voltages and the DER current(s) to the nominal operating conditions for the EUT.
- c) Set (or verify) all EUT parameters including minimum import active-power *clearing time* setting to the nominal operating settings (refer to [Annex A](#) for additional detail).
- d) Record applicable settings.
- e) Referring to the reverse or minimum import active-power time test described in [Annex A](#), adjust the current to starting point I_b . The current shall be held at this value for period t_h .⁷⁷ At the end of this period, initiate the current step function.
- f) Record the time between the initiation of the step function and the occurrence of the EUT's expected response.
- g) Return the current to nominal value I_N (and reset the EUT as necessary).
- h) Repeat steps e) through g) four times for a total of five tests.
- i) For EUTs that have a range of adjustable minimum import active-power *clearing time* settings, repeat steps c) through h) at the minimum and maximum minimum import active-power *clearing time* settings.
- j) For *multiphase* systems that control each phase individually, repeat steps e) through h) for each phase individually and all phases simultaneously.

5.10.5.3.3 Requirements

The reverse or minimum import active power *clearing time* setting of the EUT shall be specified for each of these tests.

5.10.5.3.4 Criteria

The EUT shall be considered in compliance if it ceases to energize the *ac test source* and trips within the specified *clearing time* during all tests.

In order to use this function for unintentional islanding protection, it must be set to operate within the *clearing time* requirements of 8.1 of IEEE Std 1547-2018.

5.10.5.3.5 Comments

Under some system configurations and conditions, one of the ways the unintentional islanding requirement may be met is with reverse or minimum import active power flow protection.

5.11 Open phase⁷⁸

5.11.1 Purpose

The purpose of this test is to verify that the DER ceases to energize the *area EPS* upon loss of an individual phase at the *point of DER connection*.

⁷⁷The variable t_h is at least two times the *clearing time* setting. This number may be adjusted to avoid conflict with other trip points.

⁷⁸This test is intended to demonstrate compliance with the individual phase requirement of the cease-to-energize functionality test of IEEE Std 1547. It is noted that loss of a phase is a common *area EPS* occurrence.

5.11.2 Procedure

Single-phase two-wire DERs shall be subjected to steps a) through e) only. *Multiphase* and single-phase three-wire DERs shall be subjected to steps a) through f). If the EUT requires the use of an isolation transformer, it shall be tested with the isolation transformer and the open phase condition shall be applied on the *area EPS* side of the transformer. The transformer turns ratio may have any convenient value, provided the winding configuration is as specified by the DER manufacturer.

Single-phase two-wire EUTs and split-phase EUTs that cannot source or sink current on the neutral connection may use data from the load rejection overvoltage test given in 5.17.2 (at zero load) to satisfy this test.⁷⁹

- a) Connect the EUT in accordance with the instructions and specifications provided by the manufacturer through individual phase conductor disconnects on each ungrounded phase to an *ac test source*.
- b) Set DER and *ac test source* parameters to the nominal operating conditions for the EUT.
- c) Open one phase conductor disconnect while the EUT is operating at the greater of
 - 1) 5% of rated output current or
 - 2) The EUT's minimum output current rating.
- d) Record the *clearing time*.
- e) Repeat steps c) through d) four times for a total of five tests.⁸⁰
- f) Repeat steps c) through e) for all remaining phase conductor disconnects.

5.11.3 Requirements

If used, the *ac test source* shall meet the requirements of 4.6.1. The measurement system shall meet the requirements of 4.6.3.

5.11.4 Criteria

After the disconnect is opened, the EUT shall cease to energize all output terminals connected to the *ac test source* within the timing requirement specified in 6.2.2 of IEEE Std 1547-2018 for open phase conditions.

5.11.5 Comments

CAUTION

With *multiphase* EUT, it is advisable to predetermine if opening one phase at a time could cause a ferroresonant overvoltage. Where the EUT is connected to the *ac test source* through an isolation transformer, opening one or two phases between the transformer and the *ac test source*, and the subsequent cease-to-energize response by the EUT, will result in the transformer being energized by only one or two phases, one of several necessary conditions for ferroresonance. Ferroresonant overvoltages can be several times greater than nominal voltage and should be avoided. A very small resistive load (on the order of a few percent of the transformer rating) may be added to avoid ferroresonance. This small load is not expected to materially affect the primary objectives of this test.

⁷⁹For single-phase EUTs and split-phase EUTs that cannot source or sink current on the neutral connection, opening one phase has the same effect as opening both lines, so the open phase is the same test as the LROV test with no load connected. Therefore, the data from the LROV test with no load connected can be used to evaluate compliance with IEEE 1547 open phase requirements.

⁸⁰The reconnect time may be adjusted for testing convenience.

For DER that employ either wye-delta or wye-wye transformers with solidly grounded wye windings, a full voltage may be present at the DER despite the open phase when the transformer is lightly loaded. This may cause the DER to attempt to enter service after tripping in response to the open phase.

5.12 Current distortion

5.12.1 Purpose

The purpose of this test is to measure the harmonic current distortion, inter-harmonic current distortion and *total rated-current distortion* (TRD) of the DER interconnection component or system under normal operating conditions. The objective of the test is to measure DER current distortion levels under balanced type-test conditions.⁸¹ The results shall comply with the requirements of IEEE Std 1547; however, compliance under all possible field conditions would not be guaranteed. Current distortion at certain frequencies or ranges of frequencies that occur in the field may exceed the values determined in the identified tests for the following primary reasons:⁸²

- a) Presence of elevated voltage distortion in the *area EPS*.
- b) Presence of fundamental-frequency voltage imbalance (negative sequence voltage) in the *area EPS*.
- c) Harmonic impedances in the *area EPS* differing from those used for the test source to which the EUT is connected, particularly where series resonances occur.

Compliance of the DER excludes harmonics currents caused by voltage distortion in the *area EPS*.

The load bank, when used in these tests, shall be composed only of a resistive branch for unity power factor, a resistive branch in parallel with an inductive branch for lagging power factor, and a resistive branch in parallel with a capacitive branch for leading power factor. The resistive branch shall have no intentionally added inductance or capacitance. The capacitive branch shall be composed solely of capacitor units without intentionally added inductance or resistance. The inductive branch shall have an X/R greater than 10 at the fundamental frequency and shall have no intentionally added capacitance.

5.12.2 Current distortion test for DER not capable of operation isolated from external source

5.12.2.1 Overview

This test is primarily intended for DER not capable of independently producing fundamental-frequency voltage, but it may be used to test any DER type. If the EUT requires the use of an isolation transformer, it shall be tested with the isolation transformer. The transformer turns ratio may have any convenient value provided the winding configuration is as specified by the DER manufacturer. The current distortion measurement point shall be at the isolation transformer connection to the *ac test source*.

⁸¹Some levels of unbalance would be expected when testing using an actual grid. Refer to 4.6.1 for guidance on limits regarding voltage imbalance.

⁸²Voltage source inverters and rotating generators are best characterized as harmonic voltage sources in series with harmonic impedances (Thevenin equivalent sources) at many harmonic frequencies, and thus the harmonic current flow will depend on the total impedance at each harmonic frequency of the circuit formed by the EUT and the *area EPS*, plus any intervening components such as transformers, etc., as well as the presence of any external voltage sources at the harmonic frequency.

The current distortion measurement point shall be at the isolation transformer output, before the connection point to the *ac test source*, and before the transformer connection to the load bank if the ac source requires a load to operate.

5.12.2.2 Procedure

The procedure is as follows:

- a) Connect the EUT according to the instructions and specifications provided by the manufacturer to an *ac test source* and to a load bank connected in parallel. If a grid simulator that can sink power is used, then the use of a load bank is optional.
- b) Set all input source parameters and EPS parameters to the nominal operating conditions for the EUT.
- c) With the EUT operating at normal operating temperature and inside the normal EPS voltage and frequency operating range of the unit, operate the EUT at each of the four test conditions defined in [Table 20](#), respectively, and record the current distortion parameters for each phase during each operating condition. The current distortion parameters to be recorded are comprised of the rms value of the *total rated-current distortion* (TRD), as defined in IEEE Std 1547, and the rms values of the first 50 individual harmonic current distortion and individual inter-harmonic current distortion sub-groups as described in IEEE Std 1547.

Table 20—Current distortion test cases for DER not capable of operation isolated from external source

Test case	EUT conditions
1	Rated kVA at maximum injection p.f., minimum rated Vdc (if applicable)
2	Unity p.f., nominal rated Vdc, 100% of rated active power
3	Rated kVA at maximum absorption p.f., maximum rated Vdc (if applicable)
4	Apparent power level at which manufacturer has declared % TRD is maximum

5.12.2.3 Requirements

The DER shall be operated in parallel with a source having an output impedance of less than 0.05 per unit at the fundamental frequency on the rated voltage and apparent power rating of the EUT. This impedance shall be predominately inductive. While under test, the incremental harmonic voltage (in excess of the measured test source voltage distortion) at the EUT terminals shall not be greater than $0.05 \times h \times I(h)$, where $I(h)$ is the measured harmonic current at harmonic order h . When an EUT's input power source voltage and frequency parameters affect the output power quality, the tests are to be performed with the least favorable input parameters.

The *ac test source* shall not exhibit dependence upon the equipment being tested or use algorithms to cancel or correct the *ac test source* waveform in response to the harmonics generated by the equipment being tested.

The voltage harmonics of the ac test source, as measured with the EUT connected and operating in steady state at rated power, shall be less than 3.0% total harmonic distortion (THD) inclusive of all even-order and odd-order harmonics, and interharmonics.

The *ac test source* used for this test shall not have voltage harmonics exceeding the limits in [Table 21](#) and [Table 22](#) without the EUT connected. Any aggregated interharmonics voltage distortion between $h + 5$ Hz and $(h + 1) - 5$ Hz shall be limited to the lesser magnitude limit of h and $h + 1$ harmonic order in [Table 21](#) and [Table 22](#).

Table 21 —Maximum odd harmonic voltage distortion in percent of fundamental voltage amplitude

Individual harmonic order h	$h < 11$	$11 \leq h < 17$	$17 \leq h < 23$	$23 \leq h < 35$	$35 \leq h < 50$
Percent (%)	2.0	1.0	0.75	0.3	0.15

Table 22 —Maximum even harmonic voltage distortion in percent of fundamental voltage amplitude

Individual harmonic order h	$h = 2$	$h = 4$	$h = 6$	$8 \leq h < 50$
Percent (%)	0.5	1.0	1.5	Associated range specified in Table 21

Equipment used for these tests shall be compliant with IEC 61000-4-30 Class A.

5.12.2.4 Criteria

The current distortion parameters including the *total rated-current distortion* (TRD), the first 50 individual harmonic currents, and the individual inter-harmonic current components shall not exceed the limits specified in 7.3 of IEEE Std 1547-2018. For *multiphase* EUTs, each of the phases shall comply with the specified limits.

5.12.2.5 Comments

If the measured current distortion parameters exceed the allowable levels in 7.3 of IEEE Std 1547-2018, it should be verified that the *ac test source* is not the source of current distortion. This may be accomplished by measuring the current distortion of the *ac test source* when operating against a load bank at the same tested power levels without the EUT being connected. If the results of this secondary test indicate that the *ac test source* current distortion contributions are significant, a lower distortion *ac test source* may be required.

5.12.3 Current distortion test for DER capable of operation isolated from external source

5.12.3.1 Overview

As an alternate method for EUT capable of operation isolated from an external source,⁸³ verification of compliance with current distortion limits when operating directly connected to a load bank shall be allowed.

5.12.3.2 Procedure

The procedure is as follows:

- a) Connect the EUT according to the instructions and specifications provided by the manufacturer to a load bank.

⁸³Self-excited induction generators and synchronous generators are examples of DER capable of isolated operation.

- b) With the EUT operating at normal operating temperature and inside the normal EPS voltage and frequency operating range of the unit, operate the EUT at the four test conditions defined in Table 23 with load bank load set at same conditions, respectively, and record the current distortion parameters for each phase during each operating condition. The current distortion parameters to be recorded are comprised of the rms value of the *total rated-current distortion* (TRD), as defined in IEEE Std 1547, and the rms values of the first 50 individual harmonic current distortion and individual inter-harmonic current distortion sub-groups as described in IEEE Std 1547.

Table 23—Current distortion test cases for DER capable of operation isolated from external source

Test case	EUT conditions
1	Rated kVA at maximum injection p.f., minimum rated Vdc (if applicable)
2	Unity p.f., nominal rated Vdc, 100% of rated active power
3	Rated kVA at maximum absorption p.f., maximum rated Vdc (if applicable)
4	Apparent power at which manufacturer has declared % TRD is maximum

5.12.3.3 Requirements

Equipment used for these tests shall be compliant with IEC 61000-4-30 Class A.

5.12.3.4 Criteria

The individual odd and even harmonics, rms of inter-harmonics, and TRD shall not exceed the limits specified in IEEE Std 1547. For *multiphase* EUT, each of the phases shall comply with the specified limits.

5.13 Limit active power

5.13.1 Purpose

This test confirms the EUT's capability to limit active power as required in 4.6.2 of IEEE Std 1547-2018. It also confirms that the EUT properly prioritizes voltage-active power mode requirements and frequency-droop response requirements over active power limiting as required in 4.7 of IEEE Std 1547-2018. For EUTs in normal operating performance Category A of IEEE Std 1547-2018, voltage-active power mode capability is not required, but the mode shall be tested here if the EUT is capable.

5.13.2 Procedure

The procedure is as follows:

- a) Connect the EUT according to the instructions and specifications provided by the manufacturer. Apply the default settings from IEEE Std 1547 for voltage-active power mode. Apply the default settings from frequency-droop response in IEEE Std 1547 for the *abnormal operating performance category* of the DER. Enable voltage-active power mode.⁸⁴
- b) Establish nominal operating conditions as specified by the manufacturer at the terminals of the EUT. Make available sufficient input power for the EUT to reach its rated active power. Allow (or

⁸⁴Frequency-droop response is enabled by default per IEEE Std 1547.

command) the EUT to reach steady-state output at its rated active power. Begin recording EUT active power.

- c) Apply an active power limit to the EUT of 66% of its rated active power. Wait until the EUT active power reaches a new steady state.
- d) Reduce the frequency of the *ac test source* to 59 Hz and hold until EUT active power reaches a new steady state. Return *ac test source* frequency to nominal and hold until EUT active power reaches steady state.
- e) Increase the frequency of the *ac test source* to 61 Hz and hold until EUT active power reaches steady state. Return *ac test source* frequency to nominal and hold until EUT active power reaches steady state.
- f) Increase the voltage of the *ac test source* to 1.08 times nominal and hold until EUT active power reaches steady state. Return *ac test source* voltage to nominal.
- g) Repeat steps b) through f) using active power limits of 33% and zero.
- h) Repeat steps b) through g) twice for a total of three repetitions.

5.13.3 Requirements

Throughout this procedure, available active power from the DER input source shall be sufficient to allow the EUT to reach its rated active power. The available active power shall not be intentionally modified.

5.13.4 Criteria

In step c), the EUT steady-state active power shall be reduced to the commanded percentage of its rated power plus $1.5 \times$ (MRA of active power) or less within a time that complies with 4.6.2 of IEEE Std 1547-2018.

In steps d) and e), the EUT steady-state active power shall be modulated in accordance with the equations in Table 23 of IEEE Std 1547-2018 within the tolerance as defined in 4.2 of this standard.⁸⁵ The response time shall comply with 4.6.2 of IEEE Std 1547-2018.

In step f), the EUT steady-state active power shall be modulated in accordance with the applied volt-watt curve within the tolerance as defined in 4.2 of this standard. For the 66% power level, the expected power, P_{expected} , is

$$P_{\text{expected}} = P_{\text{rated}} - (P_{\text{rated}} - P_2)(V_{\text{meas}}/V_{\text{nom}} - 1.06)/0.04$$

where P_{rated} is the EUT rated power, P_2 is as defined in IEEE Std 1547-2018, V_{meas} is the measured voltage at the RPA after the EUT power has reached steady state, and V_{nom} is the nominal voltage at the RPA. For the 33% and zero power levels, the EUT power is not expected to change.

Where the EUT is DER equipment that does not produce power such as a *plant controller*, the EUT's commanded active power may be used to verify operation. In such cases a *design evaluation* and/or *commissioning test* may be needed to verify correct operation of the installed DER.

⁸⁵Note that the equation for high-frequency conditions in Table 23 of IEEE Std 1547-2018 as published contains an important typographical error (a subtraction operator “−” is incorrectly shown as an addition operator “+”). The error was subsequently corrected in the published errata:

https://standards.ieee.org/content/dam/ieee-standards/standards/web/documents/erratas/1547-2018_errata.pdf

5.13.5 Comments

For EUTs capable of operating as part of a system that controls local loads to limit active power export to the *area EPS*, as allowed in IEEE Std 1547, controllable load(s) may be included in this test to confirm the functionality. In this case, the measured active power at the simulated PCC (rather than EUT active power) shall be measured and evaluated against the test criteria. If the EUT may be used in applications where the RPA is the PCC, the EUT may also be tested according to the UL 1741 Power Control Systems requirements to quantify and validate the EUT's response time to changes in local load and generation. The information provided by this additional test on the dynamic responses of the system may be used in *DER evaluations*. *Commissioning tests* may also be required.

EUTs capable of limiting active power either with or without controllable loads shall be tested without controllable loads and may also be tested with controllable loads. If the load control functionality is not type tested, that functionality shall be confirmed through a *DER evaluation* and/or *commissioning test* if the as-built DER will rely on it.

The test results report shall list whether the test was run with controllable load(s), without controllable load, or both with and without. If run with controllable load(s), the details of the load control system shall be included in the test report or attached to it, for consideration in *DER evaluations* (Clause 8); additional tests may be needed during commissioning if the load control system differs from that tested. If the UL 1741 Power Control Systems test procedure is used, that shall be reported, and the time to reach steady-state conditions following step changes in local load and generation shall be reported.

5.14 Voltage regulation

5.14.1 Overview

The tests in this subclause verify an EUT's reactive power capability and verifies the operation of the various voltage regulation modes described in IEEE Std 1547. Five categories of voltage regulation testing follow:

- Constant power factor mode
- Voltage-reactive power (volt-var) mode
- Voltage-active power (volt-watt) mode
- Active power-reactive power (watt-var or $P-Q$) mode
- Constant reactive power mode

5.14.2 Test requirements

During all the tests from 5.14.3 to 5.14.10, the voltage regulation functions are designed to change the grid voltage. The test facility shall maintain the applicable voltage between $\pm 1\%$ of the *ac test source* voltage setting in accordance with 4.6.1. This may be done by using a voltage source with low enough impedance, or providing loads to compensate for the EUT's active and reactive power output. The *ac test source* shall meet the requirements of 4.6.1. The measurement system shall meet the requirements of 4.6.3. The term a_v , is used throughout these tests and is defined as 150% of the minimum required measurement accuracy (MRA) for voltage, as specified in Table 3 of IEEE Std 1547-2018 for steady-state conditions.

The manufacturer shall state the following parameters of the EUT for the tests in 5.14:

- P_{rated} – output power rating (W)
- P'_{rated} – for EUTs that can sink power, output power rating while sinking power (W)

- S_{rated} – apparent power rating (VA)
- V_{in_nom} – for an EUT with an electrical input, nominal input voltage (V)
- V_{in_min} – for an EUT with an electrical input, minimum input voltage (V)
- V_{in_max} – for an EUT with an electrical input, maximum input voltage (V)
- V_N – nominal output voltage (V)
- V_L – minimum output voltage in the continuous operating region (V)
- V_H – maximum output voltage in the continuous operating region (V)
- P_{min} – minimum active power (W)
- P'_{min} – for EUTs that can sink power, minimum active power while sinking power (W)
- $Q_{rated,abs}$ – maximum absorbed reactive power (var)
- $Q_{rated,inj}$ – minimum injected reactive power (var)
- EUT's normal operating performance category defined by IEEE Std 1547
- If applicable, implemented communication protocols from Table 41 in IEEE Std 1547-2018

Throughout every procedure within 5.14, *ac test source* voltage shall be stepped to each new value within one grid cycle, and EUT power shall be ramped at the maximum rate, according to the manufacturer's instructions. During the test in 5.14, the *ac test source* voltage stays within the continuous operating voltage defined in 6.4.2 of IEEE Std 1547-2018. For every procedure within 5.14, the EUT power shall be set within $\pm 7.5\%$ of the desired setting.

Reactive capability, absorption and injection, shall be demonstrated under full rated power at V_L , V_N , V_H . Reactive power capability may be demonstrated during any one of the tests in 5.14 by operating the EUT without signal injection at full power and $Q_{rated,inj}$ at V_L , V_N , V_H and at full power and $Q_{rated,abs}$ at V_L , V_N , V_H . To confirm the minimum reactive power capability from IEEE Std 1547, the use of signal injection is not allowed. Where power generation can be decoupled from actual voltage measurements, the use of signal injection shall be allowed in all tests within 5.14.

For EUTs conforming to a normal operating performance Category A, active and reactive power requirements, P_{rated} and Q_{max} respectively, shall be permitted to be derated linearly with voltage below nominal voltage, V_N , as follows in the equations below.

$$Q_{derated} = \frac{V}{V_N} Q_{rated} \text{ for } V < V_N$$

$$P_{derated} = \frac{V}{V_N} P_{rated} \text{ for } V < V_N$$

Throughout these tests, open loop response is evaluated. The regulation functions being tested have influence over the grid, and a closed loop system is formed between the grid voltage, grid impedance and EUT. For stiff, *ac test voltage sources*, open loop system response is equivalent to the closed loop response. Annex I addresses the relationship between open loop response and closed loop response. Annex I also address how closed-loop response may be used in place of open loop response to evaluate EUTs upon agreement between the manufacturer and test lab.

For tests with imbalanced, three-phase voltages, the manufacturer shall state whether the EUT responds to individual phase voltages, or the average of the three-phase effective (rms) values or the positive sequence of voltages. For EUTs that respond to individual phase voltages, the response of each individual phase shall be evaluated. For EUTs that respond to the average of the three-phase effective (rms) values or the positive sequence of voltages, the total three-phase reactive and active power shall be evaluated. This verifies that three-phase EUTs meet volt-var and volt-watt applicable voltage requirements in 4.3 of IEEE Std 1547-2018. During the test specified in 5.14.3, the duration of imbalances shall be held for at least 300 s to verify that units do not trip off in accordance with 6.4.2.2 of IEEE Std 1547-2018. During all the tests specified in

5.14.4 through 5.14.7, the duration of imbalances shall be same as specified for the respective balanced voltage tests.

For tests with imbalanced, three-phase voltages, the voltages in Table 24 are used throughout subclauses 5.14.3 to 5.14.7. Where phase-to-neutral or phase-to-ground voltages are applicable voltages as defined in Table 1 and Table 2 of IEEE Std 1547-2018, the testing shall be repeated with the applicable voltages for each configuration supported by the EUT.

Table 24—Imbalanced voltage test cases

	Phase A (p.u.)	Phase B (p.u.)	Phase C (p.u.)
Case A	≥ 1.07	≤ 0.91	≤ 0.91
Case B	≤ 0.91	≥ 1.07	≥ 1.07

NOTE—Choose any phase as A, B, or C. Order does not matter.

5.14.3 Test for constant power factor (p.f.) mode

5.14.3.1 Purpose

This test verifies the EUT's operation at a fixed power factor is compliant with 5.3.2 of IEEE Std 1547-2018. This test verifies the EUT's response to changes in voltage magnitude and power when connected to an *ac test source*.

5.14.3.2 Procedure

The following parameters are defined for this test:

- PF: The commanded power factor
- $PF_{\min, \text{inj}}$: Minimum injected power factor, 0.90 for both Category A and B equipment
- $PF_{\min, \text{ab}}$: Minimum absorbed power factor, 0.97 for Category A, 0.90 for Category B
- $PF_{\text{mid, inj}}$: A power factor setting chosen to be less than 1 and greater than $PF_{\min, \text{inj}}$
- $PF_{\text{mid, ab}}$: A power factor setting chosen to be less than 1 and greater than $PF_{\min, \text{ab}}$

Every time a parameter is stepped or ramped, measure and record the time domain current and voltage response for at least 4 times the maximum expected response time after the stimulus, and measure or derive, active power, apparent power, reactive power, and power factor.

The power factor test shall be carried out as follows:

- a) Connect the EUT according to the instructions and specifications provided by the manufacturer.
- b) Set all voltage trip parameters to the widest range of adjustability. Disable all reactive/active power control functions.
- c) Set all *ac test source* parameters to the nominal operating voltage and frequency.
- d) Adjust the EUT's available active power to P_{rated} . For an EUT with an input voltage range, set the input voltage to $V_{\text{in, nom}}$. The EUT may limit active power throughout the test to meet reactive power requirements.
- e) Enable constant power factor mode and set the EUT power factor to $PF_{\min, \text{inj}}$.
- f) Wait for steady state to be reached.

- g) Step the EUT's active power to P_{\min} .
- h) Step the EUT's available active power to P_{rated} .
- i) Step the *ac test source* voltage to $(V_L + a_v)$.
- j) Step the *ac test source* voltage to $(V_H - a_v)$.
- k) Step the *ac test source* voltage to $(V_L + a_v)$.
- l) For *multiphase* units, step the *ac test source* voltage to V_N .
- m) For *multiphase* units, step the *ac test source* voltage to Case A from Table 24.
- n) For *multiphase* units, step the *ac test source* voltage to V_N .
- o) For *multiphase* units, step the *ac test source* voltage to Case B from Table 24.
- p) For *multiphase* units, step the *ac test source* voltage to V_N .
- q) Disable constant power factor mode. Power factor should return to unity.
- r) Verify all reactive/active power control functions are disabled.
- s) Repeat steps d) through p) for additional power factor settings: $PF_{\min,ab}$, $PF_{\text{mid,inj}}$, $PF_{\text{mid,ab}}$.
- t) For an EUT with an input voltage range, repeat steps d) through p) for $V_{\text{in_min}}$ and $V_{\text{in_max}}$.
- u) Steps d) through f) may be repeated to test additional communication protocols.

5.14.3.3 Criteria

Data from the test is used to confirm the EUT's operation at a fixed power factor is compliant with 5.3.2 of IEEE Std 1547-2018. After each voltage or power step, a new steady-state reactive power, Q_{final} , and steady-state active power P_{final} is measured. Instrumentation filtering may be used to reject variation during steady-state measurement. To fulfill the DER response time requirements of 5.3.2 in IEEE Std 1547-2018, the EUT shall reach $90\% \times (Q_{\text{final}} - Q_{\text{initial}}) + Q_{\text{initial}}$ within 10 s after a voltage or power step.

Following each voltage and power step in the test procedure, Q_{final} shall meet the test result accuracy requirements specified in 4.2 where Q_{final} is the *Y* parameter and P_{final} is the *X* parameter. The relationship between active and reactive power for constant power factor is given by the following equation:

$$Q(P) = P \sqrt{\frac{1}{PF^2} - 1}$$

Where EUT is DER equipment that does not produce power, such as a *plant controller*, the DER's commanded power factor or commanded reactive power may be used to verify compliance at the DER *design evaluation* stage. Because the unit does not produce power, signal injection may be used.

5.14.4 Test for voltage-reactive power (volt-var) mode

5.14.4.1 Purpose

This test verifies the EUT's operation with voltage-reactive power (volt-var) mode enabled is compliant with 5.3.3 of IEEE Std 1547-2018. This test verifies the EUT's response to changes in voltage magnitude when connected to an *ac test source* with a fixed V_{Ref} .

5.14.4.2 Procedure

The parameters in Figure 9, Table 25, Table 26, and Table 27 define the volt-var characteristics to be tested.

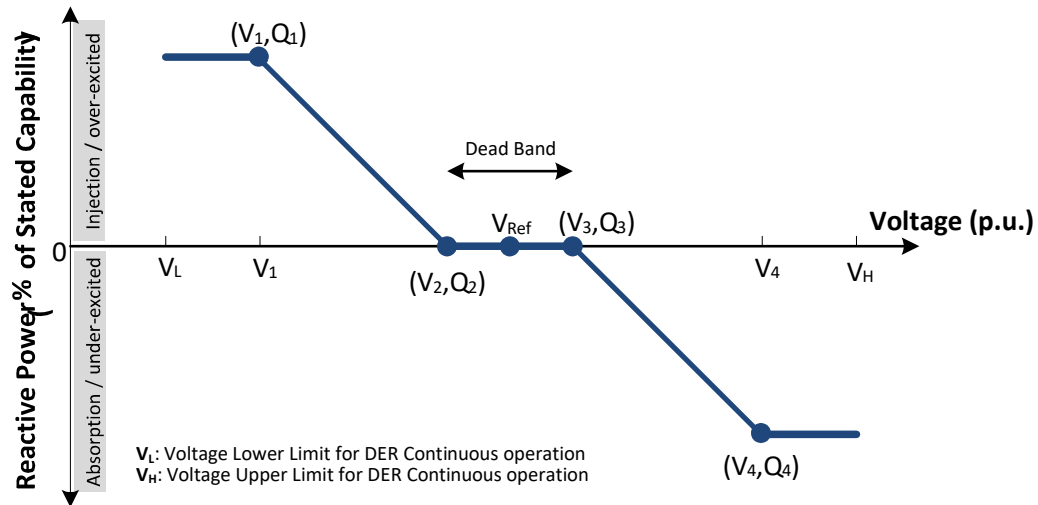

Figure 9—Example voltage-reactive power characteristic

Table 25—Characteristic 1:
Default voltage-reactive power settings for normal operating performance
Category A and Category B DER

Voltage-reactive power parameters	Default values for DER	
	Category A	Category B
V_{Ref}	V_N	V_N
V_2	V_N	$0.98 V_N$
Q_2	0	0
V_3	V_N	$1.02 V_N$
Q_3	0	0
V_1	$0.9 V_N$	$0.92 V_N$
Q_1	25% of nameplate apparent power rating, injection	44% of nameplate apparent power rating, injection
V_4	$1.1 V_N$	$1.08 V_N$
Q_4	25% of nameplate apparent power rating, absorption	44% of nameplate apparent power rating, absorption
Open loop response time, T_r	10 s	5 s

**Table 26 —Characteristic 2:
Voltage-reactive power settings for normal operating performance
Category A and Category B DER**

Voltage-reactive power parameters	Values for DER	
	Category A	Category B
V_{Ref}	1.05 V_N	1.05 V_N
V_2	1.04 V_N	1.04 V_N
Q_2	50% of nameplate reactive power capability, injection	50% of nameplate reactive power capability, injection
V_3	1.07 V_N	1.07 V_N
Q_3	50% of nameplate reactive power capability, injection	50% of nameplate reactive power capability, injection
V_1	0.88 V_N	0.88 V_N
Q_1^a	100% of nameplate reactive power capability, injection	100% of nameplate reactive power capability, injection
V_4	1.1 V_N	1.1 V_N
Q_4	100% of nameplate reactive power capability, absorption	100% of nameplate reactive power capability, absorption
Open loop response time, T_r	1 s	1 s

**Table 27 —Characteristic 3:
Voltage-reactive power settings for normal operating performance
Category A and Category B DER**

Voltage-reactive power parameters	Values for DER	
	Category A	Category B
V_{Ref}	0.95 V_N	0.95 V_N
V_2	0.93 V_N	0.93 V_N
Q_2	50% of nameplate reactive power capability, absorption	50% of nameplate reactive power capability, absorption
V_3	0.96 V_N	0.96 V_N
Q_3	50% of nameplate reactive power capability, absorption	50% of nameplate reactive power capability, absorption
V_1	0.9 V_N	0.9 V_N
Q_1^a	100% of nameplate reactive power capability, injection	100% of nameplate reactive power capability, injection
V_4	1.1 V_N	1.1 V_N
Q_4	100% of nameplate reactive power capability, absorption	100% of nameplate reactive power capability, absorption
Open loop response time, T_r	90 s	90 s

Every time a parameter is stepped or ramped, measure and record the time domain current and voltage response for at least 4 times T_r after the stimulus and measure or derive, active power, apparent power, reactive power, and power factor.

The voltage-reactive power mode test shall be carried out as follows:

- a) Connect the EUT according to the instructions and specifications provided by the manufacturer.

- b) Set all voltage trip parameters to the widest range of adjustability. Disable all reactive/active power control functions.
- c) Set all *ac test source* parameters to the nominal operating voltage and frequency.
- d) Adjust the EUT's available active power to P_{rated} . For an EUT with an electrical input, set the input voltage to $V_{\text{in_nom}}$. The EUT may limit active power throughout the test to meet reactive power requirements.
- e) Set EUT volt-var parameters to the values specified by Characteristic 1. All other function should be turned off. Turn off the autonomously adjusting reference voltage.
- f) Verify volt-var mode is reported as active and that the correct characteristic is reported.
- g) Once steady state is reached, Begin the adjustment to V_{H} . Step the *ac test source* voltage a_v below V_3 .
- h) Step the *ac test source* voltage to a_v above V_3 .
- i) Step the *ac test source* voltage to $(V_3 + V_4)/2$.
- j) If V_4 is less than V_{H} , step the *ac test source* voltage to a_v below V_4 , else skip to step l).
- k) Step the *ac test source* voltage to a_v above V_4 .
- l) Step the *ac test source* voltage to a_v below V_{H} .
- m) Begin the return to V_{Ref} . If V_4 is less than V_{H} , step the *ac test source* voltage to a_v above V_4 , else skip to step o).
- n) Step the *ac test source* voltage to a_v below V_4 .
- o) Step the *ac test source* voltage to $(V_3 + V_4)/2$.
- p) Step the *ac test source* voltage to a_v above V_3 .
- q) Step the *ac test source* voltage to a_v below V_3 .
- r) Step the *ac test source* voltage to V_{Ref} .
- s) Begin the adjustment to V_{L} . Step the *ac test source* voltage to a_v above V_2 (V_{b}).
- t) Step the *ac test source* voltage to a_v below V_2 (V_{b}).
- u) Step the *ac test source* voltage to $(V_2 + V_1)/2$.
- v) If V_1 is greater than V_{L} , step the *ac test source* voltage to a_v above V_1 , else skip to step x).
- w) Step the *ac test source* voltage to a_v below V_1 .
- x) Step the *ac test source* voltage to a_v above V_{L} .
- y) Begin the return to V_{Ref} . If V_1 is greater than V_{L} , step the *ac test source* voltage to a_v below V_1 , else skip to step z).
- z) Step the *ac test source* voltage to a_v above V_1 .
- aa) Step the *ac test source* voltage to $(V_2 + V_1)/2$.
- bb) Step the *ac test source* voltage to a_v below V_2 .
- cc) Step the *ac test source* voltage to a_v above V_2 .
- dd) Step the *ac test source* voltage to V_{Ref} .
- ee) Repeat test steps e) through dd) with V_{Ref} set to $1.05 \times V_{\text{N}}$ and $0.95 \times V_{\text{N}}$, respectively.
- ff) Repeat test steps d) through ee) at EUT power set at 20% and 66% of rated power.
- gg) Repeat steps e) through ee) for characteristics 2 and 3.

5.14.4.3 Criteria

Data from the test is used to confirm the manufacturer's stated ratings. After each voltage, a new steady-state reactive power, Q_{final} , and steady-state voltage V_{final} is measured. To obtain a steady-state value, measurements shall be taken at a time period much larger than the open loop response, T_r , setting of the volt-var function. As a guideline, at 2 times the open loop response time setting, the steady-state error is 1%. In addition, instrumentation filtering may be used to reject any variation in *ac test source* voltage during steady-state measurement.

After each voltage, the open loop response time, T_r , is evaluated. The expected reactive power output, $Q(T_r)$, at one times the open loop response time, is calculated as $90\% \times (Q_{\text{final}} - Q_{\text{initial}}) + Q_{\text{initial}}$.

Q_{final} shall meet the test result accuracy requirements specified in 4.2, where Q_{final} is the Y parameter and V_{final} is the X parameter.

$Q(T_r)$ shall meet the test result accuracy requirements specified in 4.2, where $Q(T_r)$ is the Y parameter and T_r is the X parameter.

Where EUT is DER equipment that does not produce power, such as a *plant controller*, the DER's commanded power factor or commanded reactive power may be used to verify compliance at the DER *design evaluation* stage. Because the unit does not produce power, signal injection may be used.

5.14.5 Test for voltage-reactive power (volt-var) mode (V_{Ref} test)

5.14.5.1 Purpose

This test verifies the EUT's operation with voltage-reactive power (volt-var) mode enabled is compliant with 5.3.3 of IEEE Std 1547-2018. This test verifies the EUT's response to changes in voltage magnitude when connected to an *ac test source* with an autonomously adjusting reference voltage, V_{Ref} .

5.14.5.2 Procedure

Every time a parameter is stepped or ramped, measure and record the time domain current and voltage response for at least 4 times T_{ref} , the low-pass filter time constant setting for the reference voltage, V_{Ref} , after the stimulus and measure or derive, active power, apparent power, reactive power, and power factor.

The voltage-reactive power mode test shall be carried out as follows:

- a) Connect the EUT according to the instructions and specifications provided by the manufacturer.
- b) Set all voltage trip parameters to the widest range of adjustability. Disable all reactive/active power control functions.
- c) Set all *ac test source* parameters to the nominal operating voltage and frequency.
- d) Adjust the EUT's available active power to P_{rated} . For an EUT with an electrical input, set the input voltage to $V_{\text{in_nom}}$. The EUT may limit active power throughout the test to meet reactive power requirements.
- e) Set EUT volt-var parameters to the values specified by Characteristic 1. All other functions should be turned off. Enable the autonomously adjusting V_{Ref} and set T_{ref} to 300 s.
- f) Verify volt-var mode is reported as active and that the correct characteristic is reported. Verify T_{ref} is reported back correctly.
- g) Once steady state is reached, read and record the EUT's active power, reactive power, voltage, and current measurements.
- h) Step the *ac test source* voltage to $(V_3 + V_4)/2$.
- i) Step the *ac test source* voltage to $(V_2 + V_1)/2$.
- j) Repeat test steps b) through i) with T_{ref} set at 5000 s.

5.14.5.3 Criteria

Data from the test is used to confirm the manufacturer's stated ratings. After each voltage or power step, a new steady-state reactive power, Q_{final} , shall be determined. To obtain a steady-state value, Q_{final} may be

measured at a time period much larger than the voltage reference low-pass filter time constant, T_{ref} , setting of the volt-var function. As a guideline, at 2 times the open loop response time setting, the steady-state error is 1%. In addition, filtering may be used to reject any variation in *ac test source* voltage during steady-state measurement.

The reactive power output at 1 times the voltage reference low-pass filter time constant, T_{ref} , $Q(T_{\text{ref}})$, shall be less than 10% of Q_4 for increasing voltage and shall be less than 10% of Q_1 for decreasing voltage.

Where EUT is DER equipment that does not produce power, such as a *plant controller*, the DER's commanded power factor or commanded reactive power may be used to verify compliance at the DER *design evaluation* stage. Because the unit does not produce power, signal injection may be used.

5.14.6 Test for voltage—reactive power (volt-var) mode with an imbalanced grid

5.14.6.1 Purpose

This test verifies the EUT's operation with voltage-reactive power (volt-var) mode enabled is compliant with 5.3.3 of IEEE Std 1547-2018 during voltage disturbances within the continuous operation range defined in 6.4.2.2 of IEEE Std 1547-2018 with an imbalanced grid (i.e., with a nonzero negative sequence component). This test verifies the EUT's response to changes in voltage magnitude when connected to an *ac test source* with a fixed V_{Ref} .

5.14.6.2 Procedure

The Voltage-Reactive power mode under unbalanced conditions test shall be carried out as follows:

- a) Connect the EUT according to the instructions and specifications provided by the manufacturer.
- b) Set all voltage trip parameters to the widest range of adjustability. Disable all reactive/active power control functions.
- c) Set all *ac test source* parameters to the nominal operating voltage and frequency.
- d) Adjust the EUT's available active power to P_{rated} . For an EUT with an electrical input, set the input voltage to $V_{\text{in_nom}}$. The EUT may limit active power throughout the test to meet reactive power requirements.
- e) Set EUT volt-var parameters to the values specified by the default volt-var settings in Characteristic 1. All other function should be turned off. Turn off the autonomously adjusting reference voltage.
- f) Verify volt-var mode is reported as active and that the correct characteristic is reported.
- g) Once steady state is reached, begin the adjustment of phase voltages.
- h) For *multiphase* units, step the *ac test source* voltage to Case A from [Table 24](#).
- i) For *multiphase* units, step the *ac test source* voltage to V_{N} .
- j) For *multiphase* units, step the *ac test source* voltage to Case B from [Table 24](#).
- k) For *multiphase* units, step the *ac test source* voltage to V_{N} .
- l) Where an EUT has more than one setting for the response to unbalanced voltages, repeat steps a) through k) to verify each setting.

5.14.6.3 Criteria

Data from the test is used to confirm the manufacturer's stated ratings. After each voltage step, a new steady-state reactive power, Q_{final} , and steady-state voltage V_{final} is measured. To obtain a steady-state value, measurements shall be taken at a time period much larger than the open loop response, T_r , setting of the volt-var function. As a guideline, at 2 times the open loop response time setting, the steady-state error is

1%. In addition, instrumentation filtering may be used to reject any variation in *ac test source* voltage during steady-state measurement.

After each voltage step, the open loop response time, T_r , is evaluated. The expected reactive power output, $Q(T_r)$, at one times the open loop response time, is calculated as $90\% \times (Q_{\text{final}} - Q_{\text{initial}}) + Q_{\text{initial}}$.

Q_{final} shall meet the test result accuracy requirements specified in 4.2 where Q_{final} is the *Y* parameter and V_{final} is the *X* parameter.

$Q(T_r)$ shall meet the test result accuracy requirements specified in 4.2 where $Q(T_r)$ is the *Y* parameter and T_r is the *X* parameter.

Where EUT is DER equipment that does not produce power, such as a *plant controller*, the DER’s commanded power factor or commanded reactive power may be used to verify compliance at the DER *design evaluation* stage. Because the unit does not produce power, signal injection may be used.

5.14.7 Test for active power-reactive power mode (watt-var)

5.14.7.1 Purpose

This test verifies the EUT’s operation with active power-reactive power (watt-var) mode enabled is compliant with 5.3.4 of IEEE Std 1547-2018. This test verifies the EUT’s response to changes in active power when connected to an *ac test source*.

5.14.7.2 Procedure

The parameters in Figure 10, Table 28, Table 29, and Table 30 define a watt-var characteristic to be tested. The term a_p , is 150% of the minimum required measurement accuracy (MRA) for power, as specified in Table 3 of IEEE Std 1547-2018 for steady-state conditions.

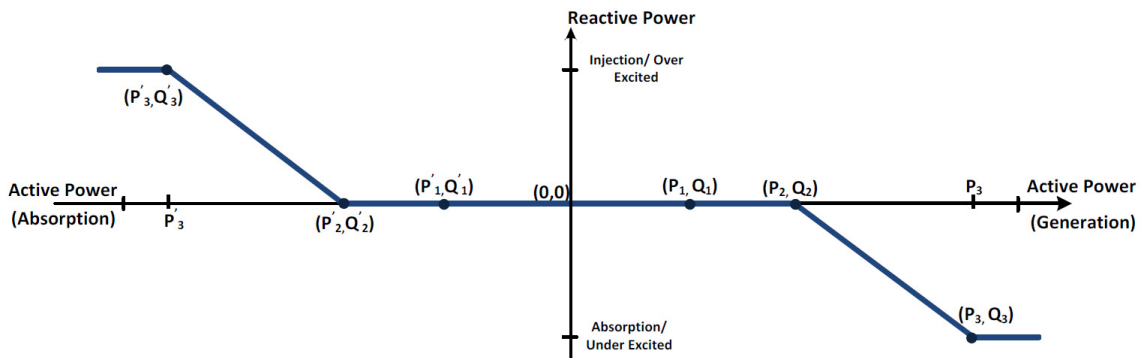

Figure 10—Example active power-reactive power characteristic

**Table 28—Characteristic 1:
Default active power-reactive power settings for normal operating performance
Category A and Category B DER**

Active power-reactive power parameters	Default values for DER	
	Category A	Category B
P_3	P_{rated}	
P_2	$0.5 P_{\text{rated}}$	
P_1	The greater of $0.2 P_{\text{rated}}$ and P_{min}	
P'_1	The lesser of $0.2 P'_{\text{rated}}$ and P'_{min}	
P'_2	$0.5 P'_{\text{rated}}$	
P'_3	P'_{rated}	
Q_3	25% of nameplate apparent power rating, absorption	44% of nameplate apparent power rating, absorption
Q_2	0	
Q_1	0	
Q'_1	0	
Q'_2	0	
Q'_3	44% of nameplate apparent power rating, injection	
NOTE— P_{rated} is the nameplate active power rating of the DER. P'_{rated} is the maximum active power that the DER can absorb. P_{min} is the minimum active power output of the DER. P'_{min} is the minimum, in amplitude, active power that the DER can absorb. P' parameters are negative in value.		

**Table 29—Characteristic 2:
Active power-reactive power settings for normal operating performance
Category A and Category B DER**

Active power-reactive power parameters	Values for DER	
	Category A	Category B
P_3	P_{rated}	
P_2	$0.5 P_{\text{rated}}$	
P_1	The greater of $0.2 P_{\text{rated}}$ and P_{min}	
P'_1	The lesser of $0.2 P'_{\text{rated}}$ and P'_{min}	
P'_2	$0.5 P'_{\text{rated}}$	
P'_3	P'_{rated}	
Q_3	25% of nameplate apparent power rating, absorption	44% of nameplate apparent power rating, absorption
Q_2	13% of nameplate apparent power rating, absorption	22% of nameplate apparent power rating, absorption
Q_1	13% of nameplate apparent power rating, absorption	22% of nameplate apparent power rating, absorption
Q'_1	22% of nameplate apparent power rating, injection	
Q'_2	22% of nameplate apparent power rating, injection	
Q'_3	44% of nameplate apparent power rating, injection	
NOTE— P_{rated} is the nameplate active power rating of the DER. P'_{rated} is the maximum active power that the DER can absorb. P_{min} is the minimum active power output of the DER. P'_{min} is the minimum, in amplitude, active power that the DER can absorb. P' parameters are negative in value.		

**Table 30—Characteristic 3:
Active power-reactive power settings for normal operating performance
Category A and Category B DER**

Active power-reactive power parameters	Values for DER	
	Category A	Category B
P_3	P_{rated}	
P_2	$0.5 P_{\text{rated}}$	
P_1	The greater of $0.2 P_{\text{rated}}$ and P_{min}	
P'_1	The lesser of $0.2 P'_{\text{rated}}$ and P'_{min}	
P'_2	$0.5 P'_{\text{rated}}$	
P'_3	P'_{rated}	
Q_3	25% of nameplate apparent power rating, absorption	44% of nameplate apparent power rating, absorption
Q_2	25% of nameplate apparent power rating, absorption	44% of nameplate apparent power rating, absorption
Q_1	0	
Q'_1	0	
Q'_2	44% of nameplate apparent power rating, injection	
Q'_3	44% of nameplate apparent power rating, injection	
NOTE— P_{rated} is the nameplate active power rating of the DER. P'_{rated} is the maximum active power that the DER can absorb. P_{min} is the minimum active power output of the DER. P'_{min} is the minimum, in amplitude, active power that the DER can absorb. P' parameters are negative in value.		

Every time a parameter is stepped or ramped, measure and record the time domain current and voltage response for at least 4 times T_r after the stimulus and measure or derive, active power, apparent power, reactive power, and power factor.

The active power -reactive power mode test shall be carried out as follows:

- a) Connect the EUT according to the instructions and specifications provided by the manufacturer.
- b) Set all *ac test source* parameters to the nominal operating voltage and frequency.
- c) Set all EUT parameters to the rated active power conditions for the EUT.
- d) Set all voltage trip parameters to default settings.
- e) Set EUT watt-var parameters to the values specified by Characteristic 1. All other functions should be turned off.
- f) Record applicable settings.
- g) Set the EUT's available active power to P_{min} .
- h) Begin the adjustment to P_{rated} . Step the EUT's available active power to a_p below P_1 .
- i) Step the EUT's available active power to a_p above P_1 .
- j) Step the EUT's available active power to $(P_1 + P_2)/2$.
- k) Step the EUT's available active power to a_p below P_2 .
- l) Step the EUT's available active power to a_p above P_2 .
- m) Step the EUT's available active power to $(P_2 + P_3)/2$.
- n) Step the EUT's available active power to a_p below P_3 .

- o) Step the EUT's available active power to a_p above P_3 .
- p) Step the EUT's available active power to P_{rated} .
- q) Begin the return to P_{min} . Step the EUT power to a_p above P_3 .
- r) Step the EUT's available active power to a_p below P_3 .
- s) Step the EUT's available active power to $(P_2 + P_3)/2$.
- t) Step the EUT's available active power to a_p above P_2 .
- u) Step the EUT's available active power to a_p below P_2 .
- v) Step the EUT's available active power to $(P_1 + P_2)/2$.
- w) Step the EUT's available active power to a_p above P_1 .
- x) Step the EUT's available active power to a_p below P_1 .
- y) Step the EUT's available active power to P_{min} .
- z) If this EUT can absorb active power, repeat steps g) through y) using P_N' values instead of P_N .
- aa) Repeat test steps f) through z) at EUT power set at 20% and 66% of rated power.
- bb) Repeat steps f) through aa) for characteristics 2 and 3.

5.14.7.3 Criteria

Data from the test is used to confirm the manufacturer's stated ratings. After each power step, a new steady-state reactive power, Q_{final} , and steady-state active power, P_{final} , is measured. To obtain a steady-state value, measurements shall be taken at a time period much larger than the required the open loop response (<10 s) of the watt-var function. As a guideline, at 2 times the open loop response time setting, the steady-state state error is 1%. In addition, instrumentation filtering may be used to reject variation in steady-state measurement.

After each power step, the open loop response time, T_r , is evaluated. The expected reactive power output, $Q(T_r)$, at one times the open loop response time, is calculated as $90\% \times (Q_{\text{final}} - Q_{\text{initial}}) + Q_{\text{initial}}$.

Q_{final} shall meet the test result accuracy requirements specified in 4.2 where Q_{final} is the Y parameter and P_{final} is the X parameter.

$Q(T_r)$ shall meet the test result accuracy requirements specified in 4.2 where $Q(T_r)$ is the Y parameter and T_r is the X parameter.

Where EUT is DER equipment that does not produce power, such as a *plant controller*, the DER's commanded power factor or commanded reactive power may be used to verify compliance at the DER *design evaluation* stage. Because the unit does not produce power, signal injection may be used.

5.14.8 Test for constant reactive power (var) mode

5.14.8.1 Purpose

This test verifies the EUT's operation at a constant reactive power setting is compliant with 5.3.5 of IEEE Std 1547-2018 and the reactive power capabilities of the EUT defined in 5.2 of IEEE Std 1547-2018. This test verifies the EUT's response to changes in voltage magnitude and power when connected to an *ac test source*.

5.14.8.2 Procedure

Every time a parameter is stepped or ramped, measure and record the time domain current and voltage response for at least 4 times T_r after the stimulus and measure or derive, active power, apparent power, reactive power, and power factor.

The constant reactive power mode test shall be carried out as follows:

- a) Connect the EUT according to the instructions and specifications provided by the manufacturer.
- b) Set all voltage trip parameters to the widest range of adjustability. Disable all reactive/active power control functions.
- c) Set all *ac test source* parameters to the nominal operating voltage and frequency.
- d) Adjust the EUT's active power to P_{rated} . For an EUT with an input voltage range, set the input voltage to $V_{\text{in_nom}}$.
- e) Enable constant var mode and set the EUT reactive power command to $Q_{\text{max,inj}}$.
- f) Verify constant var mode is reported as active and that the reactive power setting is reported as $Q_{\text{max,inj}}$.
- g) Step the EUT's active power to 20% of P_{rated} , or P_{min} , whichever is less.
- h) Step the EUT's active power to 5% of P_{rated} , or P_{min} , whichever is less.
- i) Step the EUT's active power to P_{rated} .
- j) Step the *ac test source* voltage to $(V_L + a_v)$.
- k) Step the *ac test source* voltage to $(V_H - a_v)$.
- l) Step the *ac test source* voltage to $(V_L + a_v)$.
- m) For *multiphase* units, step the *ac test source* voltage to V_N .
- n) For *multiphase* units, step the *ac test source* voltage to Case A from Table 24.
- o) For *multiphase* units, step the *ac test source* voltage to V_N .
- p) For *multiphase* units, step the *ac test source* voltage to Case B from Table 24.
- q) For *multiphase* units, step the *ac test source* voltage to V_N .
- r) Disable constant reactive power mode. Reactive power should return to zero.
- s) Verify all reactive/active power control functions are disabled.
- t) Repeat steps d) through s) for additional reactive power settings: $Q_{\text{max,ab}}$, $0.5Q_{\text{max,inj}}$, $0.5Q_{\text{max,ab}}$.
- u) For an EUT with an input voltage range, repeat steps d) through t) for $V_{\text{in_min}}$ and $V_{\text{in_max}}$.
- v) Steps d) through s) may be repeated to test additional protocols methods.

5.14.8.3 Criteria

Data from the test is used to confirm the manufacturer's stated ratings. After each voltage or power step, a new steady-state reactive power, Q_{final} is measured. The EUT shall reach 90% of Q_{final} before 10 s after a voltage or power step. Q_{final} shall meet the test result accuracy requirements specified in 4.2.

Where EUT is DER equipment that does not produce power, such as a *plant controller*, the DER's commanded power factor or commanded reactive power may be used to verify compliance at the DER *design evaluation* stage. Because the unit does not produce power, signal injection may be used.

5.14.9 Test for voltage-active power (volt-watt) mode

5.14.9.1 Purpose

This test verifies the EUT's operation with voltage-active power (volt-watt) mode enabled is compliant with 5.4.2 of IEEE Std 1547-2018. This test verifies the EUT's response to changes in voltage magnitude when connected to an *ac test source*. This test is optional for Category A equipment.

5.14.9.2 Procedure

The parameters in [Figure 11](#), [Table 31](#), [Table 32](#), and [Table 33](#) define a voltage-active power characteristic to be tested. The term a_v is 150% of the minimum required measurement accuracy (MRA) for voltage, as specified in Table 3 of IEEE Std 1547-2018 for steady-state conditions.

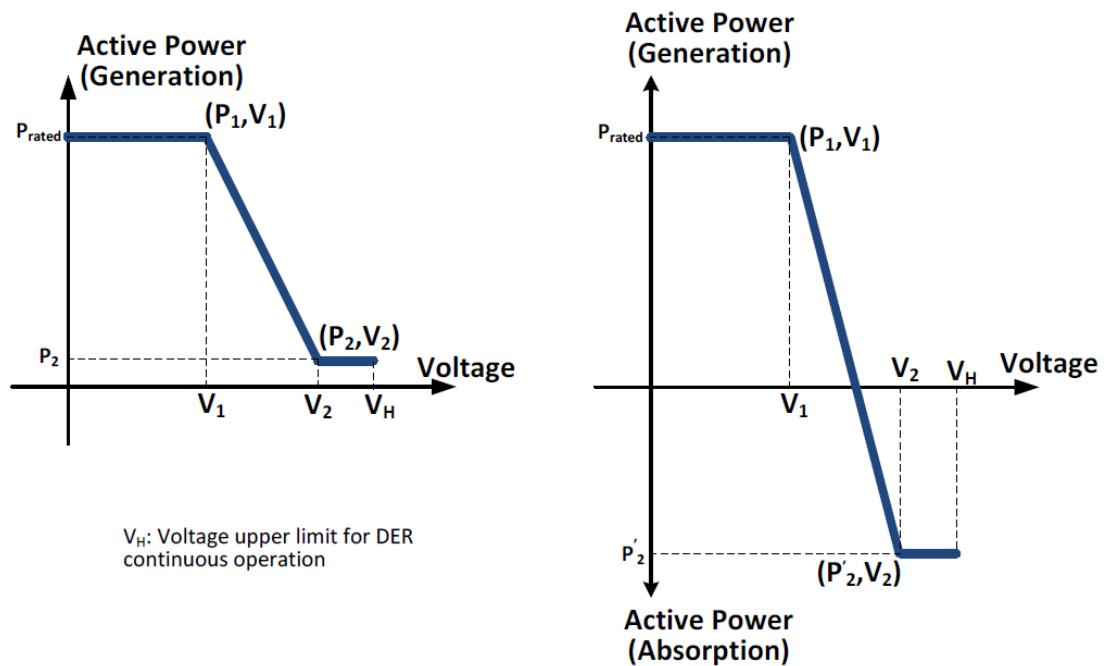

Figure 11—Example voltage-active power characteristic

**Table 31—Characteristic 1:
Default voltage-active power settings for normal operating performance
Category A and Category B DER**

Voltage-active power parameters	Default values for DER	
	Category A	Category B
V_1	$1.06 V_N$	$1.06 V_N$
P_1	P_{rated}	P_{rated}
V_2	$1.1 V_N$	$1.1 V_N$
P_2 (applicable to DER that can only generate active power)	The lesser of $0.2 P_{rated}$ or P_{min}	The lesser of $0.2 P_{rated}$ or P_{min}
P'_2 (applicable to DER that can generate and absorb active power)	0	0
Open loop response time	10 s	10 s

**Table 32—Characteristic 2:
Voltage-active power settings for normal operating performance
Category A and Category B DER**

Voltage-active power parameters	Values for DER	
	Category A	Category B
V_1	$1.05 V_N$	$1.05 V_N$
P_1	P_{rated}	P_{rated}
V_2	$1.1 V_N$	$1.1 V_N$
P_2 (applicable to DER that can only generate active power)	The lesser of $0.2 P_{rated}$ or P_{min}	The lesser of $0.2 P_{rated}$ or P_{min}
P'_2 (applicable to DER that can generate and absorb active power)	P'_{rated}	P'_{rated}
Open loop response time	90 s	90 s

**Table 33—Characteristic 3:
Voltage-active power settings for normal operating performance
Category A and Category B DER**

Voltage-active power parameters	Values for DER	
	Category A	Category B
V_1	$1.09 V_N$	$1.09 V_N$
P_1	P_{rated}	P_{rated}
V_2	$1.1 V_N$	$1.1 V_N$
P_2 (applicable to DER that can only generate active power)	The lesser of $0.2 P_{\text{rated}}$ or P_{min}	The lesser of $0.2 P_{\text{rated}}$ or P_{min}
P'_2 (applicable to DER that can generate and absorb active power)	P'_{rated}	P'_{rated}
Open loop response time	0.5 s	0.5 s

Every time a parameter is stepped or ramped, measure and record the time domain current and voltage response for at least 4 times T_r after the stimulus and measure or derive, active power, apparent power, reactive power, and power factor.

The voltage-active power mode test shall be carried out as follows:

- a) Connect the EUT according to the instructions and specifications provided by the manufacturer.
- b) Set all voltage trip parameters to the widest range of adjustability. Disable all reactive/active power control functions.
- c) Set all *ac test source* parameters to the nominal operating voltage and frequency.
- d) Adjust the EUT's active power to P_{rated} . For an EUT with an electrical input, set the input voltage to $V_{\text{in_nom}}$.
- e) Set EUT volt-watt parameters to the values specified by Characteristic 1. All other functions should be turned off.
- f) Verify volt-watt mode is reported as active and that the correct characteristic is reported.
- g) Begin the adjustment towards V_H . Step the *ac test source* voltage to a_v above V_L .
- h) Step the *ac test source* voltage to a_v below V_1
- i) Step the *ac test source* voltage to a_v above V_1 .
- j) Step the *ac test source* voltage to $(V_1 + V_2)/2$.
- k) Step the *ac test source* voltage to a_v below V_2 .
- l) Step the *ac test source* voltage to a_v above V_2 .
- m) Step the *ac test source* voltage to a_v below V_H .
- n) Step the *ac test source* voltage to a_v above V_2 .
- o) Step the *ac test source* voltage to a_v below V_2 .
- p) Step the *ac test source* voltage to $(V_1 + V_2)/2$.
- q) Step the *ac test source* voltage to a_v above V_1 .

IS 18969 : 2024

- r) Step the *ac test source* voltage to a_v below V_L .
- s) Step the *ac test source* voltage to a_v above V_L .
- t) Repeat test steps d) through s) at EUT power set at 20% and 66% of rated power.
- u) Repeat steps d) through s) for Characteristics 2 and 3.
- v) Test may be repeated for EUTs that can also absorb power using the P' values in the characteristic definition.

5.14.9.3 Criteria

Data from the test is used to confirm the manufacturer's stated ratings. After each voltage or power step, a new steady-state active power, P_{final} , and steady-state voltage V_{final} is measured. To obtain a steady-state value, measurements shall be taken at a time period much larger than the open loop response, T_r , setting of the volt-watt function. As a guideline, at 2 times the open loop response time setting, the steady-state error is 1%. In addition, instrumentation filtering may be used to reject any variation in *ac test source* voltage during steady-state measurement.

After each voltage or power step, the open loop response time, T_r , is evaluated. The expected active power output, $P(T_r)$, at one times the open loop response time, is calculated as $90\% \times (P_{\text{final}} - P_{\text{initial}}) + P_{\text{initial}}$.

P_{final} shall meet the test result accuracy requirements specified in 4.2 where P_{final} is the Y parameter and V_{final} is the X parameter.

$P(T_r)$ shall meet the test result accuracy requirements specified in 4.2 where $P(T_r)$ is the Y parameter and T_r is the X parameter.

Where EUT is DER equipment that does not produce power, such as a *plant controller*, the DER's commanded power factor or commanded reactive power may be used to verify compliance at the DER *design evaluation* stage. Because the unit does not produce power, signal injection may be used.

5.14.10 Test for voltage-active power (volt-watt) mode with an imbalanced grid

5.14.10.1 Purpose

This test verifies the EUT's operation with voltage-active power (volt-watt) mode enabled is compliant with 5.4.2 of IEEE Std 1547-2018 during voltage disturbances within the continuous operation range defined in 6.4.2.2 of IEEE Std 1547-2018 that cause an imbalanced grid with a negative sequence component. This test verifies the EUT's response to changes in voltage magnitude when connected to an *ac test source*. This test is optional for Category A equipment.

5.14.10.2 Procedure

The term a_v is 150% of the minimum required measurement accuracy (MRA) for voltage, as specified in Table 3 of IEEE Std 1547-2018 for steady-state conditions.

Every time a parameter is stepped or ramped, measure and record the time domain current and voltage response for at least 4 times T_r after the stimulus and measure or derive, active power, apparent power, reactive power, and power factor.

The voltage-active power mode test shall be carried out as follows:

- a) Connect the EUT according to the instructions and specifications provided by the manufacturer.
- b) Set all voltage trip parameters to the widest range of adjustability. Disable all reactive/active power control functions.
- c) Set all *ac test source* parameters to the nominal operating voltage and frequency.
- d) Adjust the EUT's active power to P_{rated} . For an EUT with an electrical input, set the input voltage to $V_{\text{in,nom}}$.
- e) Set EUT volt-watt parameters to the values specified by Characteristic 1, the default characteristic. All other function should be turned off.
- f) Verify volt-watt mode is reported as active and that the correct characteristic is reported.
- g) Once steady state is reached, begin the adjustment of phase voltages.
- h) For *multiphase* units, step the *ac test source* voltage to Case A from Table 24.
- i) For *multiphase* units, step the *ac test source* voltage to V_N .
- j) For *multiphase* units, step the *ac test source* voltage to Case B from Table 24.
- k) For *multiphase* units, step the *ac test source* voltage to V_N .
- l) Where an EUT has more than one setting for the response to unbalanced voltages, repeat steps a) through l) to verify each setting.
- m) Test may be repeated for EUTs that can also absorb power using the P' values in the characteristic definition.

5.14.10.3 Criteria

Data from the test is used to confirm the manufacturer's stated ratings. After each voltage or power step, a new steady-state active power, P_{final} , and steady-state voltage V_{final} is measured. To obtain a steady-state value, measurements shall be taken at a time period much larger than the open loop response, T_r , setting of the volt-watt function. As a guideline, at 2 times the open loop response time setting, the steady-state error is 1%. In addition, instrumentation filtering may be used to reject any variation in *ac test source* voltage during steady-state measurement.

After each voltage or power step, the open loop response time, T_r , is evaluated. The expected active power output, $P(T_r)$, at one times the open loop response time, is calculated as $90\% \times (P_{\text{final}} - P_{\text{initial}}) + P_{\text{initial}}$.

P_{final} shall meet the test result accuracy requirements specified in 4.2 where P_{final} is the Y parameter and V_{final} is the X parameter.

$P(T_r)$ shall meet the test result accuracy requirements specified in 4.2 where $P(T_r)$ is the Y parameter and T_r is the X parameter.

Where EUT is DER equipment that does not produce power, such as a *plant controller*, the DER's commanded power factor or commanded reactive power may be used to verify compliance at the DER *design evaluation* stage. Because the unit does not produce power, signal injection may be used.

5.15 Frequency support

5.15.1 Overview

5.15.1.1 General

The tests in this subclause verify the operation of the EUT's frequency support function as defined in IEEE Std 1547-2018. If a communication protocols from Table 41 in IEEE Std 1547-2018 is used to change EUT settings, these tests may be used to verify interoperability.

Note that a typographical error in the frequency droop equation in Table 23 of the published IEEE Std 1547-2018 was corrected in a published erratum, available at https://standards.ieee.org/content/dam/ieee-standards/standards/web/documents/erratas/1547-2018_errata.pdf.

5.15.1.2 Requirements

The *ac test source* shall meet the requirements of 4.6.1. The measurement system shall meet the requirements of 4.6.3. The *ac test source* shall not change frequency by more than 10 mHz per one p.u. of the EUT's active power rating. For every procedure within 5.15, the EUT power shall be set within $\pm 7.5\%$ of the desired setting.

Where power generation can be decoupled from actual frequency measurements, the use of signal injection shall be allowed in all tests within 5.15. For rotating machine-based DER, maximum available active power shall be permitted to be reduced linearly with frequency below nominal frequency, f_N , following the equation below:

$$P_{\text{derated}} = \frac{f}{f_N} P_{\text{rated}} \text{ for } f < f_N$$

Frequency shall be ramped to each new value at the ROCOF ride-through limit for the EUT's category as defined in 6.5.2.5 in IEEE Std 1547-2018.

Power shall be ramped according to the manufacturer's instructions.

5.15.2 Test for frequency-droop (frequency-power or frequency-watt) capability—above nominal frequency

5.15.2.1 Purpose

This test verifies the EUT's operation with frequency-active power (freq-watt) mode enabled is compliant with 6.5.2.7 of IEEE Std 1547-2018. This test verifies the EUT's response to changes in frequency when connected to an *ac test source*.

5.15.2.2 Procedure

The manufacturer shall state the following parameters of the EUT for this test:

- P_{rated} – Output power rating (W)
- f_N – Nominal frequency (Hz)
- f_H – Maximum frequency in the continuous operating region (Hz)
- f_L – Minimum frequency in the continuous operating region (Hz)
- ΔP_{small} – Small-signal performance (W)
- ΔP_{large} – Large-signal performance in % of rated power per minute
- EUT’s *abnormal operating performance category* defined by IEEE Std 1547-2018

The additional parameter shall be calculated as follows:

$$\Delta f_{\text{small}} = \Delta P_{\text{small}} \cdot f_N \cdot k_{\text{OF}}$$

Additionally, the parameters in Table 34 and Table 35 define a frequency-watt characteristic to be tested. The term a_f is 150% of the minimum required measurement accuracy (MRA) for frequency, as specified in Table 3 of IEEE Std 1547-2018 for steady-state conditions.

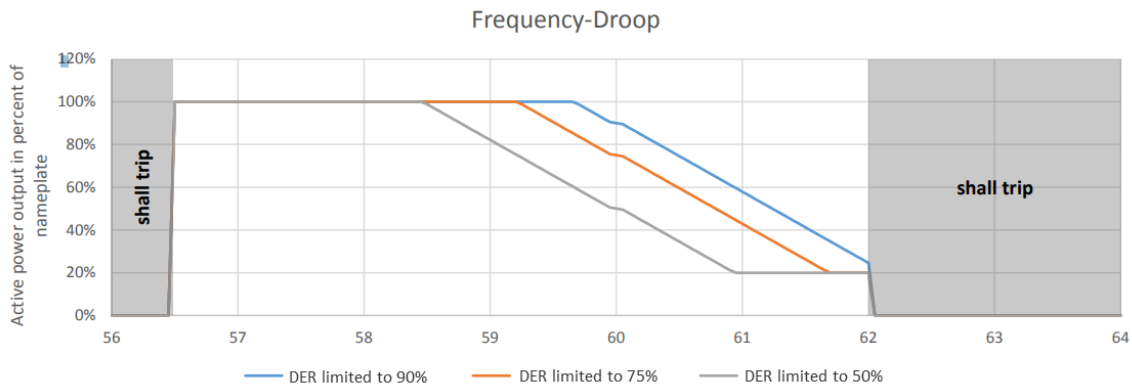

Figure 12—Example of a frequency droop function

**Table 34—Characteristic 1:
Default frequency-power power settings for abnormal operating performance
Category I, II, and III DER**

Parameter	Category I	Category II	Category III
db_{OF} (Hz)	0.036	0.036	0.036
k_{OF}	0.05	0.05	0.05
T_r (s) (small signal)	5	5	5

**Table 35—Characteristic 2:
Frequency-power power settings for abnormal operating performance
Category I, II, and III DER**

Parameter	Category I	Category II	Category III
db_{OF} (Hz)	0.017	0.017	0.017
k_{OF}	0.03	0.03	0.02
T_r (s) (small signal)	1	1	0.2

Every time a parameter is stepped or ramped, measure and record the time domain current and voltage response for at least 4 times T_r after the stimulus and measure or derive, active power, apparent power, reactive power, and power factor.

The frequency-active power mode test shall be carried out as follows:

- a) Connect the EUT according to the instructions and specifications provided by the manufacturer.
- b) Set all frequency trip parameters to the widest range of adjustability. Disable all reactive/active power control functions.
- c) Set all *ac test source* parameters to the nominal operating voltage and frequency.
- d) Adjust the EUT's active power to P_{rated} .
- e) Set EUT freq-watt parameters to the values specified by Characteristic 1. All other functions should be turned off.
- f) Verify freq-watt mode is reported as active and that the correct characteristic is reported.
- g) Once steady state is reached, read and record the EUT's active power, reactive power, voltage, frequency, and current measurements.
- h) Begin the adjustment to f_H . Ramp the frequency to a_f below $(f_N + db_{OF})$.
- i) Ramp the frequency to a_f above $(f_N + db_{OF})$.
- j) Ramp the frequency to $\Delta f_{small} + f_N + db_{OF}$.
- k) Ramp the frequency to f_H .
- l) Begin the adjustment back to f_N . Ramp the frequency to $f_H - \Delta f_{small}$.
- m) Ramp the frequency to a_f above $(f_N + db_{OF})$.
- n) Ramp the frequency to a_f below $(f_N + db_{OF})$.
- o) Ramp the frequency to f_N .
- p) Repeat test steps c) through o) with the EUT power set at 20% and 66% of rated power.
- q) Repeat steps c) through p) for Characteristic 2.
- r) For EUTs that can absorb power, rerun Characteristic 1 allowing the unit to absorb power by programming a negative P_{min} .

5.15.2.3 Criteria

Data from the test is used to confirm that the EUT follows the prescribed frequency-watt curve with the prescribed time responses. After each frequency step, a new steady-state active power, P_{final} , and a new expected steady-state active power, $P_{expected}(f_{steady})$, shall be determined. f_{steady} may be determined from the *ac test source* frequency or the EUT's reported frequency. The EUT's reported frequency shall meet the accuracy requirements of IEEE Std 1547-2018 Table 3. To obtain a steady-state value, P_{final} may be measured at a time period much larger than the open loop response, T_r , setting of the frequency-watt function. As a guideline, for an EUT with a first-order linear response (which is not required), at 2 times the open loop response time setting, the steady-state state error is 1%. In addition, filtering may be used to reject any measurement variation during steady-state measurement.

After the Δf_{small} frequency ramps, the active power output at 1 times the open loop response (T_r), $P_{\text{small}}(T_r)$, shall be calculated as $90\% \times (P_{\text{final}} - P_{\text{initial}}) + P_{\text{initial}}$. P_{small} shall meet the test result accuracy requirements specified in 4.2 where P_{small} is the Y parameter and T_r is the X parameter.

For the larger frequency ramps, the EUT shall reach steady state within $1/\Delta P_{\text{large}}$ minutes.

Where EUT is DER equipment that does not produce power, such as a plant control, the DER's commanded power may be used to verify compliance at the DER *design evaluation* stage.

5.15.3 Test for frequency-droop (frequency-power or frequency-watt) capability—below nominal frequency

5.15.3.1 Purpose

This test verifies the EUT's operation in underfrequency conditions with frequency droop (frequency-active power (frequency-watt) mode enabled. This test verifies the EUT's response to changes in frequency when connected to an *ac test source*.

5.15.3.2 Procedure

This parameter shall be calculated as follows:

$$\Delta f_{\text{small}} = \Delta P_{\text{small}} \cdot f_N \cdot k_{\text{UF}}$$

Additionally, the parameters in Table 36 and Table 37 define a frequency-watt characteristic to be tested. The term a_f is 150% of the minimum required measurement accuracy (MRA) for frequency, as specified in Table 3 of IEEE Std 1547-2018 for steady-state conditions.

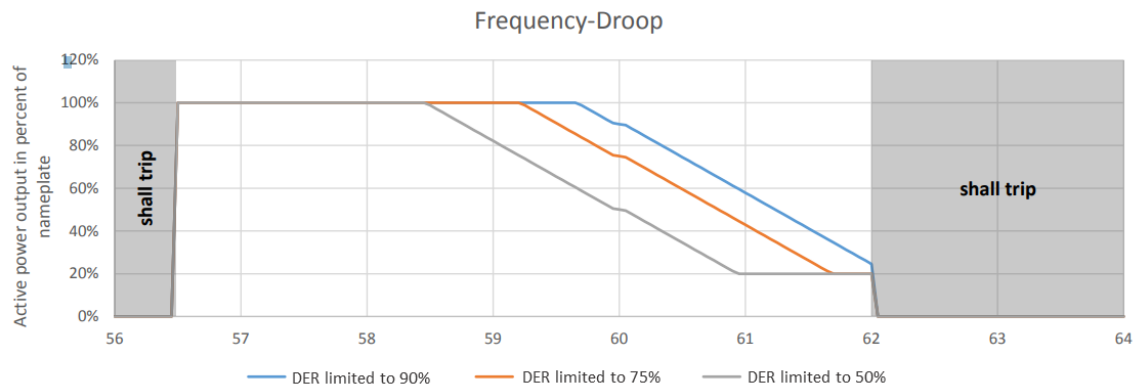

Figure 13—Example of a frequency droop function

**Table 36—Characteristic 1:
Default frequency-power settings for abnormal operating performance
Category I, II, and III DER**

Parameter	Category I	Category II	Category III
db_{UF} (Hz)	0.036	0.036	0.036
k_{UF}	0.05	0.05	0.05
T_r (s) (small-signal)	5	5	5

**Table 37—Characteristic 2:
Frequency-power settings for abnormal operating performance
Category I, II, and III DER**

Parameter	Category I	Category II	Category III
db_{UF} (Hz)	0.017	0.017	0.017
k_{UF}	0.03	0.03	0.02
T_r (s) (small-signal)	1	1	0.2

Every time a parameter is stepped or ramped, measure and record the time domain current and voltage response for at least 4 times T_r after the stimulus and measure or derive, active power, apparent power, reactive power, and power factor. Frequency is ramped at the ROCOF for the category of the EUT.

The frequency-active power mode test shall be carried out as follows:

- a) Connect the EUT according to the instructions and specifications provided by the manufacturer.
- b) Set all frequency trip parameters to the widest range of adjustability. Disable all reactive/active power control functions.
- c) Set all *ac test source* parameters to the nominal operating voltage and frequency.
- d) Adjust the EUT's available active power to P_{rated} . Set the EUT's output power to 50% of P_{rated} .
- e) Set EUT frequency-watt parameters to the values specified by Characteristic 1. All other functions should be turned off.
- f) Verify frequency-watt mode is reported as active and that the correct characteristic is reported.
- g) Begin the adjustment to f_L . Ramp the frequency to a_f above $(f_N - db_{UF})$.
- h) Ramp the frequency to a_f below $(f_N - db_{UF})$.
- i) Ramp the frequency to $f_N - \Delta f_{small} - db_{UF}$.
- j) Ramp the frequency to f_L .
- k) Begin the adjustment back to f_N . Ramp the frequency to $f_L + \Delta f_{small}$.
- l) Ramp the frequency to a_f below $(f_N - db_{UF})$.
- m) Ramp the frequency to a_f above $(f_N - db_{UF})$.
- n) Ramp the frequency to f_N .
- o) Repeat steps b) through n) for Characteristic 2.
- p) For EUTs that can absorb power, rerun Characteristic 1 allowing the unit to absorb power by programming a negative P_{min} . Set the unit to absorb power at -50% of P_{rated} .

5.15.3.3 Criteria

Data from the test is used to confirm that the EUT follows the prescribed frequency-watt curve with the prescribed time responses. After each frequency step, a new steady-state active power, P_{final} , and a new

expected steady-state active power, $P_{\text{expected}}(f_{\text{steady}})$, shall be determined. f_{steady} may be determined from the *ac test source* frequency or the EUT's reported frequency. To obtain a steady-state value, P_{final} may be measured at a time period much larger than the open loop response, T_r , setting of the frequency-watt function. As a guideline, at 2 times the open loop response time setting, the steady-state state error is 1%. In addition, filtering may be used to reject any measurement variation during steady-state measurement.

After the Δf_{small} frequency ramps, the active power output at 1 times the open loop response (T_r), $P_{\text{small}}(T_r)$, shall be calculated as $90\% \times (P_{\text{final}} - P_{\text{initial}}) + P_{\text{initial}}$. P_{small} shall meet the test result accuracy requirements specified in 4.2 where P_{small} is the Y parameter and T_r is the X parameter.

For the larger frequency ramps, the EUT shall reach steady state within $1/\Delta P_{\text{large}}$ minutes.

Where EUT is DER equipment that does not produce power, such as a plant control, the DER's commanded power may be used to verify compliance at the DER *design evaluation* stage.

5.16 Test for prioritization of DER responses

5.16.1 Test for voltage and frequency regulation priority

5.16.1.1 Purpose

This test verifies the EUT's operation and prioritization with multiple voltage and frequency regulation functions enabled. This test verifies the EUT's response to changes in both voltage and frequency when connected to an *ac test source*. This test verifies that functions are prioritized correctly by the EUT.

5.16.1.2 Requirements

The *ac test source* shall not change frequency by more than 10 mHz per one p.u. of the EUT's active power rating. The test facility shall maintain the applicable voltage between $\pm 1\%$ of the *ac test source* voltage setting in accordance with 4.6.1. This may be done by using a voltage source with low enough impedance, or providing loads to compensate for the EUT's active and reactive power output. The *ac test source* shall meet the requirements of 4.6.1. The measurement system shall meet the requirements of 4.6.3.

Throughout every procedure within 5.16.1, response time is not measured. *AC test source* voltage and frequency, and EUT power may be changed at any convenient rate. Also, the EUT power shall be set within $\pm 7.5\%$ of the desired setting.

Because DER capability is not being tested for this subclause, signal injection may be used to demonstrate the proper prioritization of voltage and frequency regulation.

5.16.1.3 Procedure

The manufacturer shall state the following parameters of the EUT for this test:

- P_{rated} – output power rating (W)
- P'_{rated} – for EUTs that can sink power, output power rating while sinking power (W)
- S_{rated} – apparent power rating (VA)
- $V_{\text{in_nom}}$ – for an EUT with an electrical input, nominal input voltage (V)

- V_{in_min} – for an EUT with an electrical input, minimum input voltage (V)
- V_{in_max} – for an EUT with an electrical input, maximum input voltage (V)
- V_N – nominal output voltage (V)
- V_L – minimum output voltage in the continuous operating region (V)
- V_H – maximum output voltage in the continuous operating region (V)
- P_{min} – minimum active power (W)
- P'_{min} – for EUTs that can sink power, minimum active power while sinking power (W)
- $Q_{max,inj}$ – maximum injected reactive power (var)
- $Q_{max,ab}$ – maximum absorbed reactive power (var)
- f_N – Nominal frequency (Hz)
- f_H – Maximum frequency in the continuous operating region (Hz)
- f_L – Minimum frequency in the continuous operating region (Hz)
- EUT's *abnormal operating performance category* defined by IEEE Std 1547-2018
- If applicable, implemented communication protocols from Table 41 in IEEE Std 1547-2018

The voltage and frequency regulation priority test shall be carried out as follows:

- a) Connect the EUT according to the instructions and specifications provided by the manufacturer.
- b) Set all voltage and frequency trip parameters to the widest range of adjustability. Disable all reactive/active power control functions.
- c) Set all *ac test source* parameters to the nominal operating voltage and frequency.
- d) Adjust the EUT's available active power to P_{rated} . For an EUT with an electrical input, set the input voltage to V_{in_nom} .
- e) Set EUT frequency-watt and volt-watt parameters to the default values for the EUT's category, and enable frequency-watt and volt-watt parameters. For volt-watt, set $P_2 = 0.2P_{rated}$.
- f) Set EUT volt-var parameters to the default values for the EUT's category and enable volt-var mode.
- g) Allow the EUT to reach steady state. Measure *ac test source* voltage and frequency and the EUT's active and reactive power production.
- h) Set the EUT's active power limit signal to 50% of P_{rated} .
- i) Allow the EUT to reach steady state.
- j) Measure *ac test source* voltage and frequency, and the EUT's active and reactive power production.
- k) Set the *ac test source* voltage and frequency to the values in step 1 of [Table 38](#) or [Table 39](#), depending on the EUT's normal operating performance category.
- l) Allow the EUT to reach steady state.
- m) Measure *ac test source* voltage and frequency, and the EUT's active and reactive power production.
- n) Repeat steps k) through m) for the rest of the steps in [Table 38](#) or [Table 39](#), depending on the EUT's normal operating performance category.
- o) Set the constant reactive power function to produce $Q_{max,inj}$. Disable the present mode of reactive power control and enable constant reactive power mode. Repeat steps g) through n).
- p) Set the constant power factor function to $PF_{max,ing}$. Disable the present mode of reactive power control and enable power factor mode. Repeat steps g) through n).
- q) Set EUT watt-var parameters to the default values for the EUT's category. Disable the present mode of reactive power control and enable watt-var mode. Repeat steps g) through n).

Table 38—Category A voltage and frequency regulation priority test steps and expected results

Step	AC test source voltage (p.u.)	AC test source frequency (Hz)	Expected active power (p.u. of rated power)	Expected reactive power for each enabled mode			
				volt-var (p.u. of rated power)	var (p.u. of rated power)	Power factor (unitless)	watt-var (p.u. of rated power)
1	1	60	0.5	0	0.44 inj	0.9 inj	0
2	1.09	60	0.4	0.25 abs	0.44 inj	0.9 inj	0
3	1.09	60.33	0.3	0.25 abs	0.44 inj	0.9 inj	0
4	1.09	60	0.4	0.25 abs	0.44 inj	0.9 inj	0
5	1.09	59.36	0.4	0.25 abs	0.44 inj	0.9 inj	0
6	1	59.36	0.6	0	0.44 inj	0.9 inj	0.05 abs
7	1	60	0.5	0	0.44 inj	0.9 inj	0
8	1	59.36	0.7	0	0.44 inj	0.9 inj	0.10 abs

Table 39—Category B voltage and frequency regulation priority test steps and expected results

Step	AC test source voltage (p.u.)	AC test source frequency (Hz)	Expected active power (p.u. of rated power)	Expected reactive power for each enabled mode			
				volt-var (p.u. of rated power)	var (p.u. of rated power)	Power factor (unitless)	watt-var (p.u. of rated power)
1	1	60	0.5	0	0.44 inj	0.9 inj	0
2	1.09	60	0.4	0.44 abs	0.44 inj	0.9 inj	0
3	1.09	60.33	0.3	0.44 abs	0.44 inj	0.9 inj	0
4	1.09	60	0.4	0.44 abs	0.44 inj	0.9 inj	0
5	1.09	59.36	0.4	0.44 abs	0.44 inj	0.9 inj	0
6	1	59.36	0.6	0	0.44 inj	0.9 inj	0.09 abs
7	1	60	0.5	0	0.44 inj	0.9 inj	0
8	1	59.36	0.7	0	0.44 inj	0.9 inj	0.18 abs

5.16.1.4 Criteria

By deliberately choosing operating points that exercise the simultaneous operation of multiple functions, data from this test is used to check the prioritization of functions. After each step, a new steady-state active power, P_{final} ; reactive power, Q_{final} ; steady-state voltage, V_{steady} ; and steady-state frequency F_{steady} is measured. To obtain a steady-state value, measurements shall be taken after a time period much larger than any of the function's open loop response time. As a guideline, at 2 times the open loop response time setting, the steady-state state error is 1%. In addition, instrumentation filtering may be used to reject any variation in *ac test source* voltage during steady-state measurement.

The expected P_{final} and Q_{final} are outlined in [Table 38](#) or [Table 39](#), depending on the EUT's normal operating performance category. The expected Q_{final} , outlined in [Table 38](#) and [Table 39](#) changes depending on which reactive power mode is under test. The values in [Table 38](#) and [Table 39](#) represent the expected values based on the voltage and frequency *settings*; the criteria are evaluated using the *measured* voltage and frequency, as stated below.

P_{final} shall meet the test result accuracy requirements specified in [4.2](#) where P_{final} is the Y parameter and V_{steady} or F_{steady} is the X parameter, depending on which X parameters gives the largest error margin.

With volt-var enabled, Q_{final} shall meet the test result accuracy requirements specified in 4.2 where Q_{final} is the Y parameter and V_{steady} is the X parameter.

With constant reactive power mode enabled, Q_{final} shall meet the test result accuracy requirements specified in 4.2.

With power factor mode enabled, Q_{final} shall meet the test result accuracy requirements specified in 4.2 where Q_{final} is the Y parameter and P_{steady} is the X parameter. The relationship between active and reactive power for constant power factor is given by the following equation:

$$Q(P) = P \sqrt{\frac{1}{PF^2} - 1}$$

With watt-var enabled, Q_{final} shall meet the test result accuracy requirements specified in 4.2 where Q_{final} is the Y parameter and P_{steady} is the X parameter.

Where EUT is DER equipment that does not produce power, such as a *plant controller*, the DER's commanded active and reactive power may be used to verify compliance at the DER *design evaluation* stage.

5.17 Limitation of overvoltage contribution

5.17.1 Ground fault overvoltage (GFOV) test

This test is optional for all DERs. DERs may perform this test to generate information that can be used in the *DER evaluation*⁸⁶ for compliance with 7.4.1 of IEEE Std 1547-2018.

5.17.1.1 Purpose

This test procedure is intended for three-phase current-regulated DERs and generally it is not applicable to voltage source type DERs (i.e., DERs that do not employ high-bandwidth output current regulation). This test is designed to determine whether the DER causes an overvoltage condition exceeding the threshold defined as effectively grounded by 7.1 in IEEE Std C62.92.1-2016. The test results are to be used in *DER evaluation* of grounding requirements.

5.17.1.2 Procedure

The power factor shall be set to unity, and active voltage regulation features shall be disabled. Where the EUT manufacturer decides to perform the test using an external or separate transformer, the transformer may be connected between the EUT and S2 in Figure 14, which is to be considered part of the equipment being tested. The default transformer configuration is delta on grid side and wye (or grounded wye) on EUT side unless the manufacturer specifies a different winding configuration for the transformer, in which case this test shall be performed with the specified configuration. The winding configuration and impedance of the transformer shall be documented for use in the *DER evaluation*. Alternatively, this test may be performed with the loads connected in ungrounded-wye or delta.

⁸⁶The objective of this optional test is to determine whether a current-regulated DER (e.g., a typical inverter-based DER) produces ground fault overvoltage in excess of the limits of effective grounding as stated in IEEE Std C62.92.1 when the load is grounded, as discussed in IEEE Std C62.92.6. DER manufacturers may elect to perform this test to inform evaluation of the need for supplemental grounding sources (e.g., grounding transformers) in certain applications.

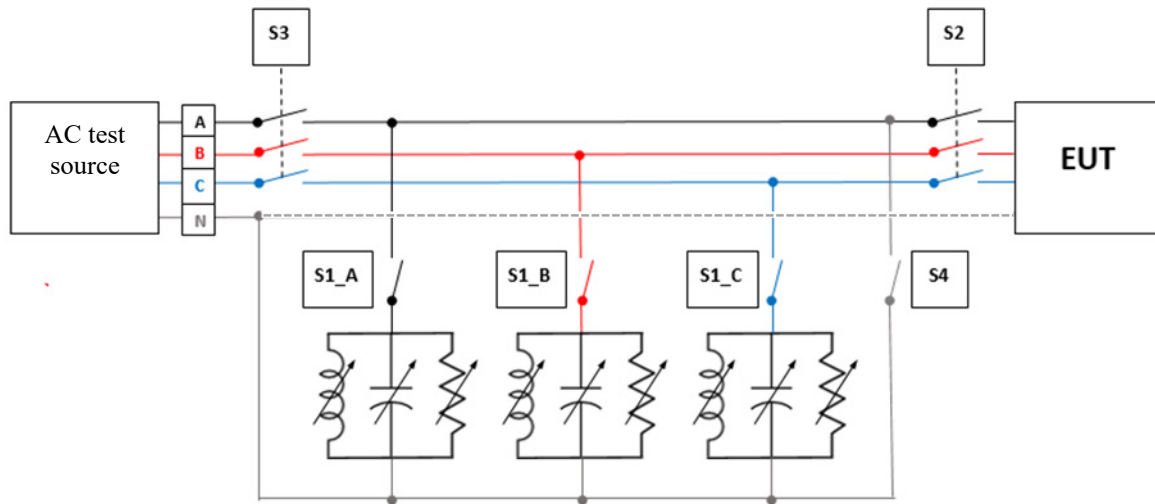

Figure 14—GFOV test circuit

- a) The test circuit shall be configured as shown in Figure 14. Optionally, the test may be performed with loads connected in ungrounded wye or delta (not shown). The neutral connection of the RLC load, the *ac test source*, and the EUT (if applicable) shall be uninterrupted by the operation of switch S3 as shown in the figure. The balanced load circuit shown in the figure is to be applied between each phase to neutral. Switch S4 is to be applied between one phase and ground. Switch S3, as shown in the figure, shall be gang-operated and multi-pole. If an *ac test source* is used that cannot sink power, it is permissible to add additional load between it and S3, sized such that the grid simulator is not required to sink output power from the EUT.
- b) Connect the EUT according to the instructions and specifications provided by the manufacturer.
- c) Set all EUT input source parameters to the nominal operating conditions for the EUT.
- d) Set (or verify) all EUT parameters to the nominal operating settings, and set overvoltage trip magnitude and *clearing time* to the maximum values of the ranges of adjustability specified in IEEE Std 1547 for these parameters.
- e) Set the EUT (including the input source as necessary) to provide 100% of its rated output power.
- f) Record all applicable settings.
- g) Set the *ac test source* to the EUT nominal voltage $\pm 2\%$ and nominal frequency ± 0.1 Hz.
- h) Adjust the islanding load circuit in Figure 14 to provide a quality factor QF of 1.0 ± 0.05 (when QF is equal to 1.0, the following applies: $P_{qL} = P_{qC} = 1.0 \times P$).

The reactive load is balanced so that the resonant frequency f of the *island* circuit is within the underfrequency and overfrequency trip settings of the EUT and as close to nominal frequency as possible.

When tuning for the current balance in this step with a non-unity p.f. output from EUT, there will be an imbalance between the L and C load components to account for the EUT reactive current. The EUT reactive output current shall be measured and algebraically added to the appropriate reactive load component when calculating QF .
- i) Close switch S3 and wait until the EUT produces the desired power level.
- j) Adjust R , L , and C until the fundamental frequency current through switch S3 is less than 2% of the rated current of the EUT on a steady-state basis in each phase.
- k) Begin recording the voltage and current at the load side of S2.

- l) Open switch S3 and allow a stable *island* to briefly form with voltage within 10% of nominal and frequency within 0.5% of nominal.⁸⁷ Alternatively, the test may be performed by closing S4 no later than 1 cycle of the clearing of S3.
- m) Close switch S4, if not already closed, and record the voltage until the EUT ceases to energize the RLC load or until voltage has stabilized.
- n) Repeat the test two times for a total of three tests.
- o) Repeat steps e) through n) with the EUT operating at the minimum injecting power factor.
- p) Repeat steps e) through n) at the power factor that generated higher overvoltage in steps n) and o), with switch S4 connected to the other phases(s) one at a time until all phases have been tested.

5.17.1.3 Requirements

Where the EUT requires a separate input source (i.e., dc source for PV inverter) to conduct this test, that source shall not limit the power output of the EUT during the test under any conditions. The RLC load shall be tuned so that the fundamental frequency current through switch S3 is less than 2% of the rated current of the unit under test on a steady-state basis in each phase.

The test and measurement equipment shall record oscillographic data, in either COMTRADE or PQDIF format, for each instantaneous phase current and each instantaneous phase-to-neutral and phase-to-phase voltage, at the load, over the duration of the test. Anti-aliasing filters and sampling frequencies appropriate to the measurement of the fundamental frequency component shall be applied. A sampling frequency of at least 10 kHz is required. The minimum measurement accuracy shall be 1% or less of rated EUT nominal output voltage and 1% or less of rated EUT output current.

The equations for QF are based upon an ideal parallel RLC circuit. For this reason, noninductive resistors, low loss (high Q) inductors, and capacitors with low effective series resistance and effective series inductance shall be utilized in the test circuit. Iron core inductors, if used, shall not exceed a current THD of 2% when operated at nominal voltage by themselves. Power ratings of resistors should be conservatively chosen to reduce thermally induced drift in resistance values during the test.

5.17.1.4 Criteria

A voltage-duration curve is created using sampled instantaneous voltage measurements during the total time until the EUT trips.

5.17.1.5 Comments

Harmonic currents may flow between the *area EPS*, the capacitor, and the DER, complicating the situation by making it appear that current is flowing when the fundamental frequency component of current has been reduced to zero. Thus, it is important, when adjusting inductive and capacitive reactance, to use instruments that can display only the fundamental frequency component of current and power.

It is often advantageous to adjust the inductance first because that measurement is low in harmonics. The capacitance is added second so that the voltage is stable when the resistance is added. The resistive parallel load is then added and adjusted. Note that this resistance is in addition to the resistance that is inherently part of the inductive load.

⁸⁷It is recommended to run GFOV with the unintentional islanding protection function enabled. However, the protection function may be disabled in order to allow voltage and frequency to be maintained stable during the test period.

5.17.2 Load rejection overvoltage (LROV) test

5.17.2.1 Purpose

The purpose of this test is to obtain necessary information for *DER evaluation* in order to verify the effects of the *DER system* on overvoltage on the *area EPS* when switching action creates a generation-load *island*. The EUT is tested at various output power and load combinations including no load.

5.17.2.2 Procedure

This test procedure is designed to be universally applicable to all DERs, regardless of output p.f. Any reactive power compensation by the EUT should remain on during the test. Where the EUT manufacturer requires an external or separate transformer, the transformer is to be connected between the EUT and the resistive load specified in the figure and is to be considered part of the equipment being tested. Alternatively, an inductor with the equivalent impedance matching that of the specified transformer could be connected between the EUT and the resistive load. See [Figure 15](#).

An optional low-power equivalent test/metering equipment load may be used to represent monitoring or test equipment typically present. A recommended circuit is a rectifier with a power capacity less than 5 W.⁸⁸ If an intervening transformer or inductor is used in the test, the test/metering load may be placed on either side of the transformer or inductor.

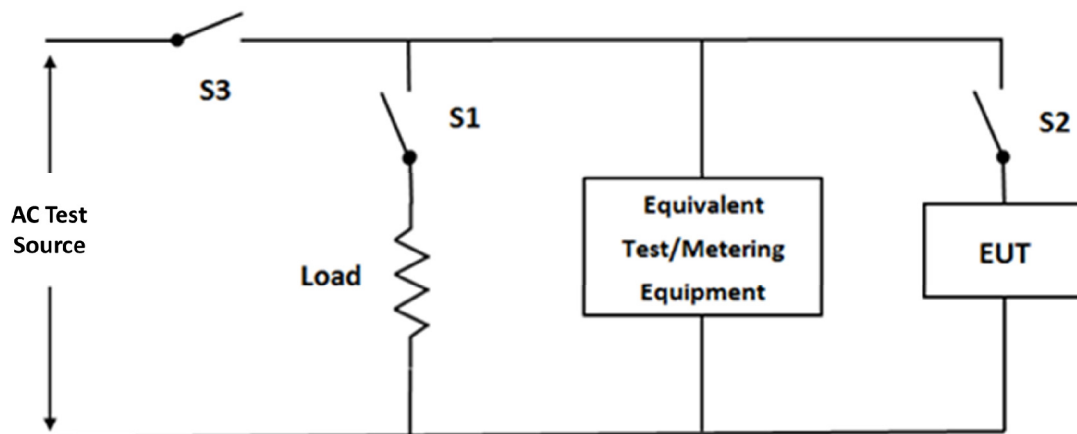

Figure 15—LROV test circuit

- a) For a single-phase EUT, the test circuit shall be configured as shown in [Figure 15](#). The neutral connection (grounded conductor) of the resistive load, the *ac test source*, and the EUT shall be unaffected by the operation of switch S3. For a *multiphase* EUT, the balanced resistive load circuit shown in the figure is to be applied between each phase to neutral for a four-wire configuration or between phases for a three-wire configuration. Switch S3 shall be gang-operated and multi-pole. Switches S1 and S2 are for setup purposes only, and not required.
- b) Connect the EUT according to the instructions and specifications provided by the manufacturer.

⁸⁸Typical loading of a revenue grade meter is around 5 W. A rectifier circuit with a small RC load is a good representation of a digital meter circuit.

- c) Set all EUT input source parameters to the nominal operating conditions for the EUT.
- d) Set (or verify) all EUT parameters to the nominal operating settings.
- e) Set the *ac test source* to the EUT nominal voltage $\pm 2\%$ and nominal frequency ± 0.1 Hz.
- f) Close switch S1, switch S2, and switch S3, and wait until the EUT produces the desired power level.
- g) Set the EUT (including the input source as necessary) to provide the desired output power $\pm 2\%$. If the EUT uses a voltage source as input, set the input source voltage within 10% of the maximum full power operating input voltage of the EUT.
- h) Adjust the load resistance so that the load power is within 2% of the desired value. See [Table 40](#).
- i) Record all applicable settings.
- j) Open switch S3 and record the voltage over time values across the load until the EUT ceases to energize the load.
- k) This test is to be performed for the following combinations of EUT output and load specified in [Table 41](#). For all of these combinations, a value of 100% is taken to mean 100% of the EUT's nameplate rating. The "Yes" or "No" entries indicate whether that test is to be performed.
- l) The tests for each output/load combination should be repeated for a total of 5 times each while making sure that switch S3 is opened at different portions on the line cycle.

Table 40—Tests to be performed

EUT output	Load value (percent of tested power level)			
	50%	33%	10%	0%
100%	Yes	Yes	Yes	Yes
66%	Yes	Yes	Yes	Yes
33%	No	No	Yes	Yes

5.17.2.3 Requirement

Where the EUT requires a separate test input source to conduct this test, that source shall not limit the power output of the EUT during the test under any conditions.

The test and measurement equipment shall record each phase current and each phase-to-neutral or phase-to-phase voltage, as appropriate, to determine fundamental frequency real and reactive power flow over the duration of the test. Anti-aliasing filters and sampling frequencies appropriate to the measurement of the fundamental frequency component and higher harmonics shall be applied. A sampling frequency of at least 10 kHz is required for load voltage and current measurements. The minimum measurement accuracy shall be 1% or less of rated EUT nominal output voltage and 1% or less of rated EUT output current.

Resistors utilized in the test circuit shall have negligible inductance as not to influence the outcome of the test. Power ratings of resistors should be conservatively chosen to reduce thermally induced drift in resistance values during the test.

5.17.2.4 Criteria

A voltage-duration curve in Figure 3 of IEEE Std 1547-2018 is created using sampled instantaneous voltage measurements during the total time until the EUT trips. The duration is the sum of cumulative period exceeding thresholds as shown in footnote 110 of IEEE Std 1547-2018.

The cumulative duration for respective voltage levels shall not exceed the limits of Figure 13 in IEEE Std 1547-2018.

5.17.2.5 Comments

The maximum recorded voltages for various load rejection conditions may prove useful in *area EPS* system protection coordination studies and should be presented with other EUT literature.

5.18 Fault current tests

The purpose of these requirements is to characterize the DER response to short-circuit faults on the distribution system as specified in 11.4 in IEEE Std 1547-2018. For devices for which generic physical models are reasonably accurate and widely accepted, including synchronous and induction generators, the parameters of those models are required to be specified by the manufacturer. For inverters, device fault response characterization shall be performed using the test procedures specified in this subclause (5.18).

5.18.1 Fault current tests for inverters

5.18.1.1 Purpose and scope

To fully understand the responses of the EPS and DER and potential impacts of DER fault response on various protective relay functions such as differential, distance and directional functions,⁸⁹ a complete set of oscillographic voltages and currents is needed. Voltage and current waveforms make it possible to determine both magnitudes and angles for all of the measured quantities under the fault condition tested.

5.18.1.2 General requirements

If the EUT includes an internal isolation transformer or if the manufacturer requires a specific external transformer, that transformer shall be considered part of the EUT. Where a specific transformer is considered part of the EUT, the complex sequence impedances, winding configuration, and kVA rating of the transformer shall be provided.

For all tests described, all data shall be collected as described in 5.18.1.5.

5.18.1.3 Test apparatus and voltage maintenance requirements

The test apparatus shall be as shown in Figure 16. Guidance for conducting testing using the grid as a primary source is given in Annex H.

⁸⁹For example, distance relays can calculate the location of a fault within a few transmission poles based on synchronous generator fault models. Some utilities have experienced the misoperation of directional relays in the vicinity of inverter-based generation, which is one example of why the phase angle information is so important for modeling and validating models of DER response.

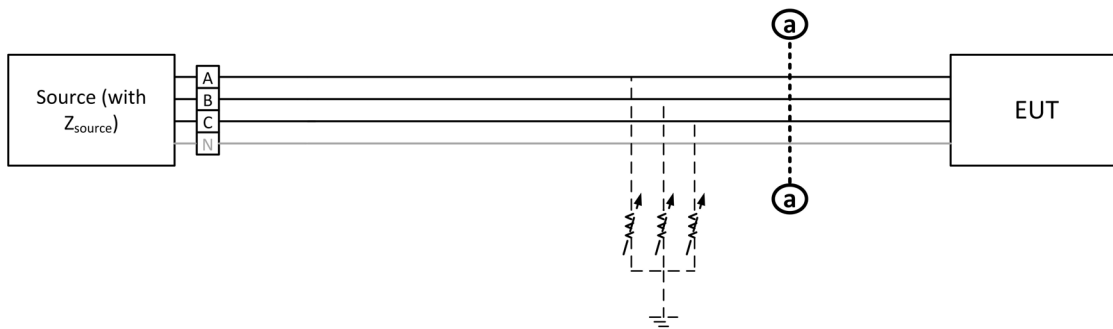

Figure 16—Test apparatus for measuring fault current response of an EUT

The source shall be sized so that it never enters any current-, voltage-, or power-limiting mode at any time during the test. The resistors shown as dashed to the left of points a-a in Figure 16 shall be used to absorb the EUT output if the programmable ac power supply is a type that cannot sink current. The following conditions shall apply:

- a) For any phase that is faulted to ground, the *ac test source* shall be configured so that the faulted phase-ground voltage(s) at Location a-a in Figure 16 are held to less than 5% of the nominal value while absorbing the EUT output current, at all EUT power factors to be tested.
- b) For any phase that is faulted to another phase, the *ac test source* shall be configured so that the phase-phase voltages at Location a-a between any two faulted phases are held to less than 5% of the nominal value while absorbing the EUT output current at all EUT power factors to be tested.
- c) For all fault tests, all unfaulted phase-ground voltage(s) shall be held to between 90% and 138% of the nominal value.
- d) For all fault tests, the frequency of the voltage at Location a-a averaged over any ten-cycle window shall remain between 59.0 Hz and 61.0 Hz.

5.18.1.4 Procedure

Each of these tests shall be run with the EUT at its full apparent power (kVA) rated output at unity power factor, minimum leading power factor and minimum lagging power factor. If the inverter has a fault ride-through dynamic voltage support or other mode in which its power factor can go to zero or nearly zero (current-voltage phase angle of $\approx \pm 90^\circ$), the inverter must be tested in that mode also. The tests must be conducted for each abnormal operating performance Category (I, II, III) in which the inverter can operate. During all tests, the input power source, such as the dc source, must be sized and operated such that it does not limit the EUT output, and the EUT voltage and frequency trip points shall be set as far from the nominal value as possible and with a *clearing time* as long as is available for these tests.

- a) **Single-phase to ground (LG) fault test:** This test applies to single-phase and three-phase inverters. For testing a single-phase EUT, the EUT must be connected to the faulted phase.
 - 1) Allow the inverter to come to steady-state output at its nominal rated output power.
 - 2) Apply the fault by causing the faulted phase-ground voltage to come to and remain within the faulted-phase voltage limits specified in 5.18.1.3a within 1 ms, while the unfaulted phase voltages continue to meet the unfaulted phase requirements in 5.18.1.3c. Repeat this test four times for a total of five samples. In each test, the fault shall occur at a different point on the voltage waveform. The data set that shall be reported as the official result of the test shall be the one that produces the longest duration of fault current.

- 3) For a three-phase inverter, repeat steps 1 through 2 for the other two phases.
 - 4) Repeat the test for all applicable fault ride-through modes and abnormal operating performance Categories as noted above.
- b) **Three-phase to ground (LLLG) fault test:** This test applies to three-phase inverters only.
- 1) Allow the inverter to come to steady-state output at its nominal rated output power.
 - 2) Apply the fault by causing all three phase-ground voltages to come to and remain within the faulted-phase voltage limits specified in 5.18.1.3a, and all phase-phase voltages come to and remain within the limit specified in 5.18.1.3b, within 1 ms. Repeat this test four times for a total of five samples. In each test, the fault shall occur at a different point on the voltage waveform. The data set that shall be reported as the official result of the test shall be the one that produces the longest duration of fault current.
- c) **Phase-phase (LL) fault test:** This test applies to three-phase inverters, and to single-phase inverters that are allowed per the manufacturer's specifications to be connected in delta to form a three-phase system. In the latter case, it is required to perform this test with three inverters connected in delta.
- 1) Allow the inverter to come to steady-state output at its nominal rated output power.
 - 2) Apply the fault by causing the faulted phase-phase voltages to come to and remain within the faulted-phase requirements specified in 5.18.1.3b in no more than 1 ms, while the unfaulted phase voltage continues to meet the unfaulted phase voltage requirements in 5.18.1.3c.
 - 3) Repeat steps 1) through 2) four times for a total of five samples. In each test, the fault shall occur at a different point on the voltage waveform. The data set that shall be reported as the official result of the test shall be the one that produces the longest duration of fault current.
 - 4) Repeat steps 1) through 3) for the other two combinations of phases (i.e., B-C and C-A).
 - 5) Repeat the test for all applicable fault ride-through modes and abnormal operating performance categories as noted above.
- d) **Phase-phase-ground (LLG) fault test:** This test applies only to three-phase inverters whose power circuits provide a zero-sequence path to ground (e.g., the inverter incorporates a transformer that is configured to provide a zero-sequence path to ground, or the three-phase inverter is comprised of three single-phase inverters connected in wye). This test is required in addition to the LL fault tests.
- 1) Allow the inverter to come to steady-state output at its nominal rated output power.
 - 2) Apply the fault by causing the faulted phase-phase voltage to come to and remain within the requirements specified in 5.18.1.3b and the phase-ground voltages of the faulted phases to come to and remain within the requirements specified in 5.18.1.3a in no more than 1 ms, while the unfaulted phase voltage continues to meet the unfaulted phase voltage requirements in 5.18.1.3c.
 - 3) Repeat steps 1) through 2) four times for a total of five samples. In each test, the fault shall occur at a different point on the voltage waveform. The data set that shall be reported as the official result of the test shall be the one that produces the longest duration of fault current.
 - 4) Repeat steps 1) through 3) for the other two combinations of phases (i.e., B-C and C-A).
 - 5) Repeat the test for all applicable fault ride-through modes and abnormal operating performance Categories as noted above.

5.18.1.5 Data requirements

The *local EPS* operator shall provide to the *area EPS operator* each line-to-ground voltage waveform, each phase current waveform, and the neutral current waveform measured at Location a-a (for the test apparatus in Figure 16) for each fault type tested, in either COMTRADE (IEEE Std C37.111) or PQDIF (IEEE Std 1159.3) format, at a minimum sampling rate of at least 10 kHz. The data window shall include a minimum of 100 ms of pre-fault data and shall be sufficiently long to capture the entire fault current transient. A clearly labeled diagram of the test setup shall be provided with the data, including descriptions of elements

and the parameters used in the test. Any parameters of the input power source (such as the dc source) that may affect the fault response of the EUT shall be provided. For the ac source, the complex positive, negative and zero-sequence impedances and the source voltage shall be provided with the test data.

5.18.2 Fault current characterization for rotating machines

5.18.2.1 Synchronous generators

Synchronous generator parameters shall be provided based on machine and exciter design data and the tests described in the most recent version of IEEE Std 115. For fault characterization of synchronous machine-based DERs, the following parameters shall be provided to the *area EPS operator* by the *local EPS operator*.

- Rated voltage (kV)
- Rated apparent power (MVA) and power factor
- Subtransient direct axis impedance, X_d''
- Subtransient quadrature axis impedance, X_q''
- Transient direct-axis impedance, X_d'
- Synchronous direct axis impedance, X_d
- Synchronous quadrature axis impedance, X_q
- Negative sequence impedance, X_2
- Zero sequence impedance, X_0
- Short-circuit direct axis subtransient time constant, T_d''
- Open-circuit direct axis subtransient time constant, T_{d0}''
- Short-circuit quadrature axis subtransient time constant, T_q''
- Open-circuit quadrature axis subtransient time constant, T_{q0}''
- Short-circuit quadrature axis transient time constant, T_q' (for cylindrical-rotor machines)
- Short-circuit direct axis transient time constant, T_d'
- Open-circuit direct axis transient time constant, T_{d0}'
- Exciter time constant, T_e
- Armature short-circuit time constant, T_a
- Stator resistance, r_s
- Field resistance, r_F
- Total (generator plus prime mover) moment of inertia, J ⁹⁰

Synchronous machine exciter data may be provided using the standard exciter definitions in IEEE Std 421.5. In this case, the user shall identify the appropriate exciter type and supply appropriate values for all of the listed parameters for that exciter type.

⁹⁰This parameter is not covered by IEEE Std 115. It may be computed either by the manufacturer or the *local EPS* owner or designer.

5.18.2.2 Asynchronous (induction) generators

Induction generator parameters shall be provided based on the tests described in the most recent version of IEEE Std 112. For asynchronous machines, the following parameters shall be provided:

- Rated voltage (kV)
- Rated apparent power (MVA) and power factor
- Stator resistance, R_S
- Stator leakage reactance, X_{LS}
- Rotor resistance, R_r
- Rotor leakage inductance, X_{LR}
- Magnetizing reactance, X_m
- Mutual inductance, L_M
- Total (generator plus prime mover) moment of inertia, J ⁹¹
- Number of poles, P

5.18.2.3 Doubly fed asynchronous machines

For EUTs utilizing doubly fed asynchronous machines, also known as doubly fed induction generators, if the EUT's rotor-circuit converter self-protects during the fault by applying a short-circuit or low impedance across its terminals (i.e., if the rotor-circuit converter “crowbars” during the fault), then the parameters listed in 5.18.2.2 shall be provided. If the EUT uses any other method to protect its rotor-circuit converter during a fault, or if it does not self-protect its rotor-circuit converter during a fault, then that EUT shall be tested using the procedure described in 5.18.1.

5.19 Persistence of DER parameter settings

5.19.1 Purpose

The purpose of this test is to confirm that DER parameter settings persist following a power cycle of the DER, when appropriate.

5.19.2 General

The EUT manufacturer shall identify the measurement point for voltage to the component responsible for storing parameter settings, to enable the tester to verify that voltage to that circuit has been removed.

This test may be run using only the DER control component responsible for storing parameter settings.

5.19.3 Procedure

The procedure is as follows:

⁹¹This parameter is not covered by IEEE Std 112. It may be computed either by the manufacturer or the *local EPS* owner or designer.

IS 18969 : 2024

- a) Select three adjustable parameters from Table 30 through Table 40 of IEEE Std 1547-2018. The three parameters shall be selected by the *testing agency* without prior knowledge of the DER manufacturer.
- b) Adjust the three parameters to values that are within their respective ranges of adjustability specified in IEEE Std 1547 and that differ from their respective initial and default values. Verify that the new values have been implemented. Record the new values.
- c) Power cycle the DER or DER control component responsible for storing parameter settings. The power cycle shall consist of removing *ac test source* voltage and disconnecting EUT input source power or shutting down EUT generation and verifying that voltage at the control component responsible for storing parameter settings has been removed for at least 60 s.⁹²
- d) Restore power to the DER and/or controller.
- e) Check and record the values of the parameters adjusted in step b).
- f) Repeat steps a) through e) two times for a total of three repetitions, selecting different parameters each time.

5.19.4 Criteria

For all parameters, the values recorded in step b) shall match the values recorded in step e).

⁹²If the DER contains a backup power supply, it may be necessary to disconnect that supply from the relevant control component to be certain voltage to the component responsible for storing parameter settings has been removed.

6. Interoperability tests

6.1 Overview

The applicable tests specified in this subclause shall be carried out to validate DER compliance with the interoperability requirements of IEEE Std 1547. Only the interoperability tests related to the functionality supported by the EUT Category under test apply. All testing specified in this subclause shall be carried out using the *local DER communication interface* specified in 10.1 in IEEE Std 1547-2018. The *local DER communication interface* shall be available and meet the communication criteria set forth in this standard at all times that the DER is operating. The phrase “communication interface” in this subclause shall refer to the *local DER communication interface* specified in IEEE Std 1547-2018.

IEEE Std 1547-2018 identifies the following three communication protocols and requires that at least one be supported. The specific version(s) and data model(s) identified in Table 41 shall be used.

Table 41—Standard communication protocol options

IEEE Std 1547-2018 protocol option	Required version/revision
IEEE Std 2030.5™	This protocol option shall refer to IEEE Std 2030.5-2018.
IEEE Std 1815™ (DNP3)	This protocol option shall refer to IEEE Std 1815-2012 and DNP3-AN-2018-001.
SunSpec Modbus ^a	This protocol option addresses revisioning through new information model numbers and shall refer to the specific models called out in 6.8.1.

^a The SunSpec Alliance manages the SunSpec Modbus specification.

The device manufacturer shall identify the IEEE 1547 communication protocol(s) and transport and physical layer(s) for which their device is to be tested. If more than one of the protocols identified by IEEE Std 1547 are supported, each protocol shall be tested for each requirement set forth in this subclause.

Listing and labeling according to this standard shall indicate the protocol(s) and transport and physical layer(s) that have passed this test. Compliance to this interoperability test shall require that the EUT pass all applicable tests in 6.4 through 6.8. For “*DER unit*” testing performed as “partially compliant” as described in 11.3.2 of IEEE Std 1547-2018, settings that apply only to the unsupported capabilities shall not be tested.

NOTE—Subsequent interoperability testing at the “*DER system*” level is required in the case of partially-compliant *DER units*.

These interoperability tests may be carried out independently, or in conjunction with functional testing specified in 5.4 through 5.15. The tests in this Clause 6 have been designed so that it is possible to incorporate interoperability testing with the functional testing to the extent possible.

As with the *type tests* in Clause 5, and as stated in IEEE Std 1547-2018, *type test* results from a DER within a product family of the same design, including hardware and software, shall be allowed as representative of other DERs within the same product family with power ratings between 50% to 200% of the tested DER.

6.2 Interoperability testing approach

The objective of interoperability testing is to verify all information associated with interoperability in IEEE Std 1547 is exchanged and acted on properly. For information that is read-only, the value that is read is verified to be correct.

For information that is read-write, the values that are written are read to verify they were correctly set in the EUT. Also, the functional behavior associated with values written is verified for at least two different values for each adjustable setting to verify the values written were correctly applied by the DER.

The interoperability test descriptions do not provide any additional functional test descriptions for functionality associated with adjustable settings. The functional test descriptions, test values, and criteria specified in the appropriate functional test requirements are used when performing interoperability testing.

The interoperability test procedures specify only what is required. It is acknowledged that use of the IEEE 1547 local DER interface for applying all the IEEE 1547.1 functional testing can enhance test efficiency and may become a best practice. This extended usage is optional and not required for interoperability compliance. It is permitted to satisfy interoperability requirements while performing the required functional testing. The interoperability tests have been organized to facilitate integration with functional testing. This interoperability test does not include test messages that are malformed or have invalid data values and accordingly does not assess DER behavior in response to such messages.

There are two parts to this test specification for all interoperability tests: a general test procedure and protocol specific test considerations. The general test procedure describes the elements of the test in a protocol independent way. It includes all the aspects required of each test description. The protocol-specific test considerations describe the protocol information necessary to perform the test. In most cases this is comprised of a simple mapping of the IEEE 1547 information element to the appropriate protocol specific information element.

6.3 General test procedures

6.3.1 Purpose

This subclause specifies the general test procedures that are required for interoperability compliance. The protocol-specific test subclauses may add additional detail for any of these tests but do not introduce any additional test procedures.

For each of the interoperability tests specified in 6.4 to 6.8, validate that the DER replies to each request within the communication time identified in Table 42 in IEEE Std 1547-2018.

6.3.2 General procedure for testing adjustable settings

This subclause specifies a general test procedure for tests that include adjustable settings. This procedure is referenced in the following test procedures:

- a) Use the local communications interface to disable the function in all cases where disabling is a required capability.
- b) Repeat the following steps such that all available settings specified in IEEE 1547 functional requirements are set to at least two different values in the testing process:

- 1) Use the communication interface to apply settings for a functional test case specified in the applicable section and enable the function if it is not already enabled.
 - 2) Use the communications interface to read the current settings.
 - 3) Verify the settings read are the same as the settings written and the function is enabled.
 - 4) Verify that the function is enabled and that the applied settings took effect using the criteria specified for the functional test case.
- c) Use the communications interface to disable the function if possible and verify the function is disabled.

6.3.3 General criteria for testing adjustable settings

This subclause specifies the following general criteria for tests that include adjustable settings:

- The function can be enabled and disabled successfully as specified in the procedure.
- All adjustable settings can be read as specified in the procedure.
- All functional tests associated with the adjustable settings applied in the procedure successfully meet the specified criteria as specified in the functional test description.

6.4 Nameplate data test

6.4.1 Purpose

Verify nameplate data can be read from the DER. The DER manufacturer shall provide expected nameplate values for the DER under test.

6.4.2 Procedure

The procedure is as follows:

- a) Read from the DER each nameplate data item listed in Table 28 in IEEE Std 1547-2018.
- b) Compare each value received to the expected values from the manufacturer-provided expected values.

6.4.3 Criteria

Criteria include that all nameplate values read match the provided expected nameplate values. If any does not match, the test fails.

6.5 Configuration information test

6.5.1 Purpose

Configuration settings are optional. If used, verify the available settings can be read and written and the settings written take effect.

6.5.2 Procedure

The procedure is as follows:

- a) Read from the DER each parameter identified in [Table 42](#).
- b) For each, verify that the value reported matches the behavior of the DER measured through independent test equipment separate from the DER interface.
- c) Adjust values as identified in [Table 42](#).
- d) Repeat steps a) and b) for the new values.
- e) Adjust parameters back to the initial values and verify that the values reported match the initial values.

Table 42—Configuration information test levels

Parameter	Adjustment required	Additional test instructions
Active power rating at unity power factor (nameplate active power rating)	Set to 80% of initial value ^a	
Apparent power maximum rating	Set to 80% of initial value ^a	
Reactive power injected maximum rating	Set to 80% of initial value ^a	
Reactive power absorbed maximum rating	Set to 80% of initial value ^a	
Active power charge maximum rating	Set to 80% of initial value ^a	This test applies only to DER that include energy storage.
Apparent power charge maximum rating	Set to 80% of initial value ^a	This test applies only to DER that include energy storage.
Supported control mode functions	Not applicable	

^aAny initial operating condition is acceptable, with the EUT manufacturer specifying what that is.

6.5.3 Criteria

Passing criteria include that supported configuration information items read in steps a) and e) shall match the values provided by the manufacturer. In addition, DER behavior shall match the adjusted configured parameters in steps b) and d). If any read value or behavior does not match, the test fails.

6.6 Monitoring information test

6.6.1 Purpose

Verify monitoring information can be read from the DER and that this information matches the actual values as measured from an independent test equipment separate from the DER interface, and within the steady-state measurement minimum accuracy specified in Table 3 in IEEE Std 1547-2018.

6.6.2 Procedure

The procedure is as follows:

- a) Set the operating conditions of the DER to the values specified in the “Operating Point A” column in [Table 43](#).

- b) Wait not less than 30 s, then read from the DER each monitoring information, and verify that the reported values match the operating conditions as specified.
- c) Change the operating conditions of the DER as specified in the “Operating Point B” column in Table 43.
- d) Repeat step b).

Table 43—Monitoring information test levels

Monitoring information parameter	Operating Point A	Operating Point B	Criteria
Active Power	20% to 30% of DER “active power rating at unity power factor.”	90% to 100% of DER “active power rating at unity power factor.”	Reported values match test operating conditions within the accuracy requirements specified in Table 3 in IEEE Std 1547-2018.
Reactive Power (Injected)	20% to 30% of DER “reactive power injected maximum rating.”	90% to 100% of DER “reactive power injected maximum rating.”	Reported values match test operating conditions within the accuracy requirements specified in Table 3 in IEEE Std 1547-2018.
Reactive Power (Absorbed)	20% to 30% of DER “reactive power absorbed maximum rating.”	90% to 100% of DER “reactive power absorbed maximum rating.”	Reported values match test operating conditions within the accuracy requirements specified in Table 3 in IEEE Std 1547-2018.
Voltage(s) <i>This test shall be applied to each of the supported applicable voltages from Table 1 or Table 2 in IEEE Std 1547-2018.</i>	At or below $0.90 \times$ (ac voltage nominal rating).	At or above $1.08 \times$ (ac voltage nominal rating).	Reported values match test operating conditions within the accuracy requirements specified in Table 3 in IEEE Std 1547-2018.
Frequency	At or below 57.2 Hz.	At or above 61.6 Hz.	Reported values match test operating conditions within the accuracy requirements specified in Table 3 in IEEE Std 1547-2018.
Operational State	On: Conduct this test while the DER is generating.	Off: If supported by the DER, conduct this test while capable of communicating but not capable of generating.	Reported Operational State matches the device present condition for on and off states.
Connection Status	Connected: Conduct this test while the DER is generating.	Disconnected: Conduct this test while permit service is disabled.	Reported Connection Status matches the device present connection condition.
Alarm Status	Has alarms set.	No alarms set.	Reported Alarm Status matches the device present alarm condition for alarm and no alarm conditions. For test purposes only, the DER manufacturer shall specify at least one way an alarm condition that is supported in the protocol being tested can be set and cleared.

^a Upon a request for information, the provided response shall be the latest value measured within the required response time. If the information is older than the response time, an error shall be indicated.

6.6.3 Criteria

Passing criteria are specified in the “Criteria” column of [Table 43](#).

6.7 Management information test

The purpose of these tests is to verify that adjustable settings can be read and written for each management function and that the settings written take effect.

For each test in [Table 44](#), use the general test procedure in [6.3.2](#) to verify all the adjustable settings specified in IEEE Std 1547 as referenced in the “Adjustable Settings” column. For each test, use the criteria in [6.3.3](#) as they apply to the criteria in the associated functional test subclause of this standard and referenced in the in the “Criteria” column of [Table 44](#).

Table 44—Management information test list

Test	Management function	Adjustable settings (references to IEEE Std 1547-2018)	Criteria (references to functional test criteria within this document)	Notes
1	Constant Power Factor Mode	10.6.2, Table 30	5.14.3.3	
2	Voltage-reactive power mode	10.6.3, Table 31	5.14.4.3 and 5.14.5.3	
3	Active power-reactive power mode	10.6.4, Table 32	5.14.7.3	
4	Constant reactive power mode	10.6.5, Table 33	5.14.8.3	
5	Voltage-active power mode	10.6.6, Table 34	5.14.9.3	
6	Voltage trip test	10.6.7, Table 35	5.4.2.4 (overvoltage trip settings) and 5.4.3.4 (undervoltage trip settings)	
8	Frequency trip test	10.6.8, Table 37	5.5.1.4 (over frequency trip) and 5.5.2.4 (under frequency trip)	
9	Frequency droop (frequency/power or frequency-watt) test	10.6.9, Table 38	5.15.2.3 (above nominal frequency) and 5.15.3.3 (below nominal frequency)	
10	Enter service and Cease to energize and trip tests	10.6.10, Table 39, 10.6.11	5.6.4	NOTE—This management function relates to permit service.
11	Limit maximum active power test	10.6.12, Table 40	5.13	

6.8 Specific protocol mappings

To interoperate and function, the device during interoperability testing shall not require the use of additional DNP, 2030.5, Modbus, or vendor specific messages/data points other than those indicated in this subclause.

Communication interface blocking/locking (a proprietary action) is not allowed per the interoperability requirements of IEEE Std 1547. This position is supported by existing language in [6.1](#), stating: “The local

DER communication interface shall be available and meet the communication criteria set forth in this standard at all times that the DER is operating.”

6.8.1 SunSpec Modbus usage

This subclause specifies additional SunSpec Modbus-specific test information for the required tests. The general test procedures, along with protocol specific information, are used to perform the tests.

All SunSpec information model usage shall comply with the appropriate SunSpec specifications.

SunSpec information models are organized based on logical information content. The information models that contain the required IEEE 1547 content are described in [6.8.1.1](#) through [6.8.1.10](#). The version of each SunSpec information model is represented by the information model ID. When a SunSpec information model is approved, the content associated with that information model ID will not change.

A SunSpec compliant Modbus master shall be used to access the DER under test. Either a Modbus serial RTU or Modbus TCP interface may be used. The Modbus master shall be used to perform the interoperability tests as described in this standard.

IEEE Std 1547-2018 allows two physical layer options for use with SunSpec Modbus (Ethernet and RS-485). Compliance to the appropriate standards shall be verified for each physical layer interface to be listed.

TLS shall not be used during the SunSpec Modbus test.

6.8.1.1 Nameplate data test

Perform the nameplate data test in [6.4](#) using the SunSpec parameters in [Table 45](#).

Table 45—SunSpec nameplate data

IEEE Std 1547-2018	SunSpec parameter	Additional information
Active power rating at unity power factor (nameplate active power rating)	702.WMaxRtg	
Active power rating at specified over-excited power factor	702.WOvrExtRtg	
Specified over-excited power factor	702.WOvrExtRtgPF	
Active power rating at specified under-excited power factor	702.WUndExtRtg	
Specified under-excited power factor	702.WUndExtRtgPF	
Apparent power maximum rating	702.VAMaxRtg	
Normal operating performance category	702.NorOpCat	
Abnormal operating performance category	702.AbnOpCat	
Reactive power injected maximum rating	702.VarMaxInjRtg	
Reactive power absorbed maximum rating	702.VarMaxAbsRtg	
Active power charge maximum rating	702.WChaRteMaxRtg	
Apparent power charge maximum rating	702.VAChaRteMaxRtg	
AC voltage nominal rating	702.VNomRtg	
AC voltage maximum rating	702.VMaxRtg	
AC voltage minimum rating	702.VMinRtg	
Supported control mode functions		
Reactive susceptance that remains connected to the <i>area EPS</i> in the cease-to-energize and trip state		
Manufacturer	1.Mn	
Model	1.Md	
Serial number	1.SN	
Version	1.Vr	

6.8.1.2 Configuration information test

Perform the configuration information test in 6.5 using the appropriate SunSpec parameters in Table 45.

6.8.1.3 Monitoring information test

Perform the monitoring information test in 6.6 using the SunSpec parameters in Table 46.

Table 46—SunSpec monitoring information

IEEE Std 1547-2018	SunSpec parameter	Additional information
Active Power	701.W	
Reactive Power	701.VAR	
Voltage	701.PPV 701.PhV	
Frequency	701.Hz	
Operational State	701.St	
Connection Status		
Alarm Status	701.Alrm	
Operational State of Charge		

6.8.1.4 Adjustable constant power factor test

Perform the adjustable constant power factor test in 5.14.3 using the SunSpec parameters in Table 47.

Table 47—SunSpec adjustable constant power factor

IEEE Std 1547-2018	SunSpec parameter	Additional information
Constant Power Factor Mode Enable	704.PFWInjEna	
Constant Power Factor	704.PFWInj.PF	
Constant Power Factor Excitation	704.PFWInj.Ext	

6.8.1.5 Voltage-reactive power function test

Perform the voltage-reactive power function test in 5.14.4 and 5.14.5 using the SunSpec parameters in Table 48.

Table 48—SunSpec voltage-reactive power

IEEE Std 1547-2018	SunSpec parameter	Additional information
Voltage-Reactive Power Mode Enable	705.Ena	
V_{Ref}	705.VRef	
Autonomous V_{Ref} Adjustment Enable	705.VRefAuto	
V_{Ref} Adjustment Time Constant	705.VRefTms	
V/Q Curve Points	705.VoltVar.Crv.Pt	
Open Loop Response Time	705.RspTms	

6.8.1.6 Active power-reactive power test

Perform the active power-reactive power test in 5.14.7 using the SunSpec parameters in Table 49.

Table 49—SunSpec active power-reactive power

IEEE Std 1547-2018	SunSpec parameter	Additional information
Active Power-Reactive Power Mode Enable	712.Ena	
P/Q Curve Points	712.WattVar.Crv.Pt	

Perform the adjustable constant reactive power test in 5.14.8 using the SunSpec parameters in Table 50.

Table 50—SunSpec adjustable constant reactive power

IEEE Std 1547-2018	SunSpec parameter	Additional information
Constant Reactive Power Mode Enable	704.FixedVarEna	
Constant Reactive Power	704.FixedVar	

Perform the voltage-active power test in 5.14.9 using the SunSpec parameters in Table 51.

Table 51—SunSpec voltage-active power

IEEE Std 1547-2018	SunSpec parameter	Additional information
Voltage-Active Power Mode Enable	706.Ena	
V/P Curve Points	706.VoltWatt.Crv.Pt.V/W	
Open Loop Response Time	706.VoltWatt.RspTms	

Perform the voltage trip test in 5.4.2 and 5.4.3 using the SunSpec parameters in Table 52.

Table 52—SunSpec voltage trip

IEEE Std 1547-2018	SunSpec parameter	Additional information
HV Trip Curve Points	708.HVRT.Crv.MustTrip.Pt.V/Tms	
LV Trip Curve Points	707.LVRT.Crv.MustTrip.Pt.V/Tms	

6.8.1.7 Frequency trip test

Perform the frequency trip test in 5.5.1 and 5.5.2 using the SunSpec parameters in Table 53.

Table 53—SunSpec frequency trip

IEEE Std 1547-2018	SunSpec parameter	Additional information
HF Trip Curve Points	710.HFRT.Crv.MustTrip.Pt.Freq/Tms	
LF Trip Curve Points	709.LFRT.Crv.MustTrip.Pt.Freq/Tms	

6.8.1.8 Frequency droop (frequency-active power or frequency-watt) test

Perform the frequency droop test in 5.15.2 and 5.15.3 using the SunSpec parameters in Table 54.

Table 54—SunSpec frequency droop

IEEE Std 1547-2018	SunSpec parameter	Additional information
Overfrequency Droop db_{OF}	711.DbOf	
Underfrequency Droop db_{UF}	711.DbUf	
Overfrequency Droop k_{OF}	711.KOf	
Underfrequency Droop k_{UF}	711.KUf	
Open Loop Response Time	711.RspTms	

6.8.1.9 Enter service test

Perform the enter service test in 5.6 using the SunSpec parameters in Table 55.

Table 55—SunSpec enter service

IEEE Std 1547-2018	SunSpec parameter	Additional information
Permit service	703.PmtSvc	
ES Voltage High	703.ESVHi	
ES Voltage Low	703.ESVLo	
ES Frequency High	703.ESHzHi	
ES Frequency Low	703.ESHzLo	
ES Delay	703.ESDlyTms	
ES Randomized Delay	703.ESRndTms	
ES Ramp Rate	703.ESRmpTms	

6.8.1.10 Limit maximum active power test

Perform the limit maximum active power test in 5.13 using the SunSpec parameters in Table 56.

Table 56—SunSpec limit maximum active power

IEEE Std 1547-2018	SunSpec parameter	Addition information
Limit Active Power Enable	704.MaxLimWEna	
Maximum Active Power	704.MaxLimW	

6.8.2 IEEE 2030.5 usage

This subclause specifies additional IEEE 2030.5-specific test information for the required tests. The general test procedures specified in 6.3, along with protocol specific information, are used to perform the tests.

All IEEE 2030.5 information model usage shall be in compliance with the appropriate specifications in IEEE Std 2030.5-2018.

An IEEE 2030.5-2018 compliant server implementation shall be used to interface with the DER under test. The server implementation shall use the IEEE 2030.5 functionality as specified in 6.8.2.1 through 6.8.2.13 to perform the interoperability tests as described in this standard.

IEEE Std 1547-2018 requires TCP/IP and an Ethernet physical layer interface with the IEEE Std 2030.5 protocol. Compliance to the IEEE 802.3 Ethernet standards shall be verified.

The server implementation shall utilize the default security policy defined in IEEE Std 2030.5-2018.

6.8.2.1 Configuration information test

Perform the configuration information test in 6.4 using the IEEE 2030.5 parameters in Table 57.

Table 57 —IEEE 2030.5 nameplate data

IEEE Std 1547-2018	IEEE 2030.5 parameter	Additional information
Active power rating at unity power factor (nameplate active power rating)	DERCapability::rtgMaxW	
Active power rating at specified over-excited power factor	DERCapability::rtgOverExcitedW	
Specified over-excited power factor	DERCapability::rtgOverExcitedPF	
Active power rating at specified under-excited power factor	DERCapability::rtgUnderExcitedW	
Specified under-excited power factor	DERCapability::rtgUnderExcitedPF	
Apparent Power Maximum Rating	DERCapability::rtgMaxVA	
Normal operating performance category	DERCapability::rtgNormalCategory	
Abnormal Operating Performance Category	DERCapability::rtgAbnormalCategory	
Reactive Power Injected Maximum Rating	DERCapability::rtgMaxVar	
Reactive Power Absorbed Maximum Rating	DERCapability::rtgMaxVarNeg	
Active Power Charge Maximum Rating	DERCapability::rtgMaxChargeRateW	
Apparent Power Charge Maximum Rating	DERCapability::rtgMaxChargeRateVA	
AC voltage nominal rating	DERCapability::rtgVNom	
AC voltage maximum rating	DERCapability::rtgMaxV	
AC voltage minimum rating	DERCapability::rtgMinV	
Supported Control Mode Functions	DERCapability::modesSupported	
Reactive susceptance that remains connected to the <i>area EPS</i> in the cease-to-energize and trip state	DERCapability::rtgReactiveSusceptance	
Manufacturer	DeviceInformation::mfID	
Model	DeviceInformation::mfModel	
Serial Number	DeviceInformation::mfSerNum	
Version	DeviceInformation::mfHwVer DeviceInformation::swVer	
Nameplate Storage Actual Capacity	DERCapability::rtgOverExcitedW	

6.8.2.2 Basic settings information test

Perform the basic settings information test in 6.5 using the appropriate IEEE 2030.5 parameters in Table 57.

6.8.2.3 Monitoring information test

Perform the monitoring information test in 6.6 using the IEEE 2030.5 parameters in Table 58.

Table 58—IEEE 2030.5 monitoring information

IEEE Std 1547-2018	IEEE 2030.5 parameter	Additional information
Active Power	ReadingType::accumulationBehaviour = 12 ReadingType::commodity = 1 ReadingType::flowDirection = 19 ReadingType::kind = 37 ReadingType::uom = 38	
Reactive Power	ReadingType::accumulationBehaviour = 12 ReadingType::commodity = 1 ReadingType::flowDirection = 19 ReadingType::kind = 37 ReadingType::uom = 63	
Voltage(s)	ReadingType::accumulationBehaviour = 12 ReadingType::commodity = 1 ReadingType::flowDirection = 1 ReadingType::phase = {phase} ReadingType::uom = 29	
Frequency	ReadingType::accumulationBehaviour = 12 ReadingType::commodity = 1 ReadingType::flowDirection = 1 ReadingType::uom = 33	
Operational State	DERStatus::operationalModeStatus	
Connection Status	DERStatus::genConnectStatus DERStatus::storConnectStatus	
Alarm Status	DERStatus::alarmStatus	
Operational State of Charge	DERStatus::stateOfChargeStatus	

6.8.2.4 Adjustable constant power factor test

Perform the adjustable constant power factor test in 5.14.3 using the IEEE 2030.5 parameters in Table 59.

Table 59—IEEE 2030.5 Adjustable Constant Power factor

IEEE Std 1547-2018	IEEE 2030.5 parameter	Additional information
Constant Power Factor Mode Enable	Active Event	
Constant Power Factor	DERControl::opModFixedPFInjectW	
Constant Power Factor Excitation	DERControl::opModFixedPFInjectW.excitation	

6.8.2.5 Voltage-reactive power function test

Perform the voltage-reactive power function test in 5.14.4 and 5.14.5 using the IEEE 2030.5 parameters in Table 60.

Table 60—IEEE 2030.5 voltage-reactive power

IEEE Std 1547-2018	IEEE 2030.5 parameter	Additional information
Voltage-Reactive Power Mode Enable	Active Event	
V_{Ref}	DERCurve::vRef	
Autonomous V_{Ref} Adjustment Enable	DERCurve::autonomousVRefEnable	
V_{Ref} Adjustment Time Constant	DERCurve::autonomousVRefTimeConstant	
V/Q Curve Points	DERControl::opModVoltVar::CurveData	
Open Loop Response Time	DERControl::opModVoltVar::openLoopTms	

6.8.2.6 Active power-reactive power test

Perform the active power-reactive power test in 5.14.7 using the IEEE 2030.5 parameters in Table 61.

Table 61—IEEE 2030.5 active power-reactive power

IEEE Std 1547-2018	IEEE 2030.5 parameter	Additional information
Active Power-Reactive Power Mode Enable	Active Event	
P/Q Curve Points	DERControl::opModWattVar::CurveData	

6.8.2.7 Adjustable constant reactive power test

Perform the adjustable constant reactive power test in 5.14.8 using the IEEE 2030.5 parameters in Table 62.

Table 62—IEEE 2030.5 adjustable constant reactive power

IEEE Std 1547-2018	SunSpec parameter	Additional information
Constant Reactive Power Mode Enable	Active Event	
Constant Reactive Power	DERControl::opModFixedVar DERControl::opModTargetVar	

6.8.2.8 Voltage-active power test

Perform the voltage-active power test in 5.14.9 using the IEEE 2030.5 parameters in Table 63.

Table 63—IEEE 2030.5 voltage-active power

IEEE Std 1547-2018	SunSpec parameter	Additional information
Voltage-Active Power Mode Enable	Active Event	
V/P Curve Points	DERControl::opModVoltWatt::CurveData	
Open Loop Response Time	DERControl::opModVoltWatt::openLoopTms	

6.8.2.9 Voltage trip test

Perform the voltage trip test in 5.4.2 and 5.4.3 using the IEEE 2030.5 parameters in Table 64.

Table 64—IEEE 2030.5 voltage trip

IEEE Std 1547-2018	IEEE 2030.5 parameter	Additional information
HV Trip Curve Points	DERControl::opModHVRTMustTrip::CurveData	
LV Trip Curve Points	DERControl::opModLVRTMustTrip::CurveData	

6.8.2.10 Frequency trip test

Perform the frequency trip tests in 5.5.1 and 5.5.2 using the IEEE 2030.5 parameters in Table 65.

Table 65—IEEE 2030.5 frequency trip

IEEE Std 1547-2018	IEEE 2030.5 parameter	Additional information
HF Trip Curve Points	DERControl::opModHFRTMustTrip::CurveData	
LF Trip Curve Points	DERControl::opModLFRTMustTrip::CurveData	

6.8.2.11 Frequency droop (frequency-active power or frequency-watt) test

Perform the frequency droop tests in 5.15.2 and 5.15.3 using the IEEE 2030.5 parameters in Table 66.

Table 66—IEEE 2030.5 frequency droop

IEEE Std 1547-2018	IEEE 2030.5 parameter	Additional information
Overfrequency Droop db_{OF}	DERControl::opModFreqDroop::dBOF	
Underfrequency Droop db_{UF}	DERControl::opModFreqDroop::dBUF	
Overfrequency Droop k_{OF}	DERControl::opModFreqDroop::kOF	
Underfrequency Droop k_{UF}	DERControl::opModFreqDroop::kUF	
Open Loop Response Time	DERControl::opModFreqDroop::openLoopTms	

6.8.2.12 Enter service test

Perform the enter service test in 5.6 using the IEEE 2030.5 parameters in Table 67.

Table 67 —IEEE 2030.5 enter service

IEEE Std 1547-2018	IEEE 2030.5 parameter	Additional information
Permit service	DERControl::opModEnergize	
ES Voltage High	DERSettings::setESHHighVolt DefaultDERControl::setESHHighVolt	
ES Voltage Low	DERSettings::setESLowVolt DefaultDERControl::setESLowVolt	
ES Frequency High	DERSettings::setESHHighFreq DefaultDERControl::setESHHighFreq	
ES Frequency Low	DERSettings::setESLowFreq DefaultDERControl::setESLowFreq	
ES Delay	DERSettings::setESDelay DefaultDERControl::setESDelay	
ES Randomized Delay	DERSettings::setESRandomDelay DefaultDERControl::setESRandomDelay	
ES Ramp Time	DERSettings::setESRampTms DefaultDERControl::setESRampTms	

6.8.2.13 Limit maximum active power test

Perform the limit maximum active power test in 5.13 using the IEEE 2030.5 parameters in Table 68.

Table 68 —IEEE 2030.5 Limit Maximum Active Power

IEEE Std 1547-2018	IEEE 2030.5 parameter	Addition information
Limit Active Power Enable	Active Event	
Maximum Active Power	DERControl::opModMaxLimW	

6.8.3 DNP3 usage

This subclause specifies additional DNP3-specific test information for the required tests. The general test procedures, along with protocol specific information, are used to perform the tests.

The DNP3 implementation shall comply with IEEE Std 1815-2012 and shall utilize the standard profile set forth in the DNP3-AN-2018-001 (known as the DNP3 app note). The protocol options in the DNP3 Device Profile for the outstation shall match those listed in subclause 2.2 “Points List” of the app note. As discussed in subclause 2.4.7 “Time Synchronization Function” of the app note, the outstation shall support the DNP3 local area network time synchronization method.

IEEE Std 1547-2018 requires TCP/IP and an Ethernet physical layer interface with the DNP3 protocol. Compliance to the Ethernet standards shall be verified.

TLS shall not be used during the DNP3 test.

6.8.3.1 General communication commissioning

Subclause 2.13 in the DNP3 app note provides a mapping reference to the communication requirements in IEEE Std 1547-2018. Table 63 in that standard identifies the specific DNP3 data points that shall be used for each readable and writable parameter in this test. For each parameter, DNP3 protocol uses separate data points for writing values (called *outputs*) and reading back the present values (called *inputs*), as referenced in Table 63 in the DNP3 app note.

The DNP3 implementation of the outstation shall comply with section 2.12 “Implementation Table” of the app note for all applicable object groups and variations. All the data points in Table 63 in the DNP3 app note shall be supported and the outstation shall comply with generic requirements in the DNP3 app note section 2.3.1 “Support for Modes and Functions.” To interoperate and function, the device under DNP3 testing shall not require the use of additional DNP3 messages or data points other than those indicated in this section, neither prior to nor during testing.

6.8.3.2 Handling of curve functions in DNP3

Section 2.3.3 in the DNP3 app note explains how curve functions are handled using this protocol and must be understood in relation to this section. Devices compliant with IEEE Std 1547-2018 shall support the multiplexed generic curve handling methods identified in section 2.3.3 in the DNP3 app note, including support of the binary input called “Selected Curve is Referenced by a Mode” and enforcing the requirement to reject attempted changes to the values of curves that are currently in use by setting the “ALREADY EXECUTING” Indication in the response.

Devices compliant with IEEE Std 1547-2018 shall support at least 10 generic curves, each capable of at least four points. This requirement establishes that there is always at least one curve index that is not in use and can be written to. Devices compliant with IEEE Std 1547-2018 shall support the discovery of curve indices that are not in use through the mechanism identified in the DNP3 app note.

6.8.3.3 Nameplate data test

IEEE 1547 nameplate data is identified in the “Nameplate Information (Energy),” “Nameplate Information (rms),” and “Nameplate Information (Other)” categories in Table 63 of the DNP3 app note. Additional test instructions are given in [Table 69](#).

Table 69—DNP3 usage for nameplate data

Nameplate data item in IEEE Std 1547-2018	Clarification and additional test instructions
Specified over-excited power factor	NOTE—Resolution is 0.01. For example, a power factor of 0.91 is represented as 91.
Reactive Power Absorbed Maximum Rating	NOTE—Values are negative.
Active Power Charge Maximum Rating	Must be supported for all DER, set to 0 for generating-only DER.
Apparent Power Charge Maximum Rating	Must be supported for all DER, set to 0 for generating-only DER.
Supported Control Mode Functions	NOTE—All binary inputs in the specified range shall be supported, BI31, BI32, BI35, BI36, BI44, BI45, BI46, BI47, BI48, BI49 Binary Inputs shall be set to “1” to reflect that these functions are supported.
Manufacturer	The DER shall support the DNP3 device attribute objects as set forth in section 2.4.1 of the DNP3 app note.
Model	
Serial Number	
Version	
Nameplate Storage Actual Capacity	Required to support the “Operational State of Charge” monitoring information.

6.8.3.4 Configuration information

For DER using the DNP3 protocol, there shall not be separate data points for configuration information. DER shall use the nameplate data points identified in Table 63 of the DNP3 app note.

6.8.3.5 Monitoring Information

DER using the DNP3 protocol shall support the monitoring points specified in the DNP3 app note Table 63 “Monitored Information” category and the monitoring steps specified in section 2.4.1 of the DNP3 app note. Clarifications and additional instructions are provided in Table 70. DNP3 monitoring information shall be read by class.

Table 70—Monitoring information

Monitoring information requirement in IEEE Std 1547-2018	Clarification and additional test instructions
Voltage(s)	For single-phase systems, the Phase A data point shall be used.
Frequency	NOTE—Units are in .001Hz. For example, 60.041Hz is represented as 60041.
Operational State	Generation-only DER shall utilize, at a minimum: BI18, BI19, BI21, BI22 Storage DER shall utilize, at a minimum: BI18, BI19, BI20, BI21, BI22
Connection Status	Covered in the Operational State Indicators
Alarm Status	DER shall support, at a minimum, alarm indicator BI1.
Operational State of Charge	NOTE—Units are 0.1%. For example, 25.3% is expressed as 253.

6.8.3.6 Constant power factor

Section 2.7.2 of the DNP3 app note identifies the steps involved in constant power factor control. Optional steps 1 through 4 shall not be used in this test and the associated features are not required. The data points of the “Constant Power Factor Mode” category in Table 63 of the DNP3 app note shall be used for this function. The DNP3 has provisions for separate settings of “Constant Power Factor” and “Constant Power

Factor Excitation” categories when generating and charging, but in this application, the same settings shall be used for both generating and charging. Table 51 in the DNP3 app note describes the use of the “Power Factor Excitation” field to get the intended quadrant of operation.

6.8.3.7 Voltage-reactive power

Section 2.7.3 of the DNP3 app note identifies the steps involved in voltage-reactive power control. For this function, step b)1) in 6.3.2 shall consist of the following protocol-specific steps identified in Table 54 of the DNP3 app note: steps 6 through 16, 18, and 19. Optional steps 1 through 5 and 17 shall not be used in this test. The test shall include at least one case in which Autonomous V_{Ref} Adjustment is enabled and one in which it is disabled.

6.8.3.8 Active power-reactive power

Section 2.7.4 of the DNP3 app note identifies the steps involved in active power-reactive power control. For this function, step b)1) in 6.3.2 shall consist of the following protocol-specific steps identified in Table 55 of the DNP3 app note: steps 7 through 13, 15, and 16. Optional steps 1 through 6 shall not be used in this test. Valid curves in IEEE Std 1547-2018 for this function shall consist of exactly 4 points.

6.8.3.9 Constant reactive power

Section 2.7.1 of the DNP3 app note identifies the steps involved in constant reactive power control. For this function, step b)1) in the test procedure in 6.3.2 shall consist of the following protocol-specific steps identified in Table 50 of the DNP3 app note: steps 10 and 11. Optional steps 1 through 9 shall not be used in this test.

The meaning of the “Constant VARs Reactive Power Target” setting shall be % of Nameplate Reactive Power Absorption Capability (when absorbing) and % of Nameplate Reactive Power Injection Capability (when injecting). With this fixed definition for IEEE Std 1547-2018, the options identified in Table 49 in the DNP3 app note are not required.

6.8.3.10 Voltage-active power

Section 2.6.7 of the DNP3 app note identifies the steps involved in voltage-active power control. For this function, step b)1) in the test procedure in 6.3.2 shall consist of protocol-specific steps 8 through 16 identified in Table 47 of the DNP3 app note. Optional steps 1 through 7, 17, and 18 shall not be used in this test. The curve mode shall be <5> for this function. Valid curves in IEEE Std 1547-2018 shall consist of exactly 4 points. The Y-values shall be assumed to be % of Max Vars, use of AO238 shall not be required.

6.8.3.11 Voltage trip

Section 2.5.1 of the DNP3 app note identifies the steps involved in voltage-trip configuration. For this function, step b)1) in the test procedure in 6.3.2 shall consist of protocol-specific steps 1 through 4, 7 through 9, and 11 through 13 identified in Table 33 of the DNP3 app note. Optional steps 5, 6, and 10 shall not be used in this test.

As specified in the DNP3 app note, separate curves are used to specify the high-voltage trip (curve type 9) and low-voltage trip (curve type 11) boundaries.

6.8.3.12 Momentary cessation

Section 2.5.1 of the DNP3 app note identifies the steps involved in momentary cessation configuration. For this function, step b)1) in the test procedure in 6.3.2 shall consist of protocol-specific steps 1 through 4, 7 through 9, and 11 through 13 identified in Table 33 of the DNP3 app note. Optional steps 5, 6, and 10 shall not be used in this test. As specified in the DNP3 app note, separate curves are used to specify the high-voltage momentary cessation (curve type 10) and low-voltage momentary cessation (curve type 12) boundaries.

6.8.3.13 Frequency trip

Section 2.5.2 of the DNP3 app note identifies the steps involved in frequency trip configuration. For this function, step b)1) in 6.3.2 shall consist of protocol-specific steps 1 through 4, 6 through 8, 10, and 11 identified in the DNP3 app note. Optional steps 5 and 9 shall not be used in this test. As specified in the DNP3 app note, separate curves are used to specify the high-frequency trip (curve type 13) and low-frequency trip (curve type 15) boundaries.

6.8.3.14 Frequency droop

Section 2.5.3 of the DNP3 app note identifies the steps involved in frequency droop configuration. For this function, step b)1) in 6.3.2 shall consist of protocol-specific steps 7, 9, 11, 13, and 23 identified in the DNP3 app note. Optional steps 1 through 6, 8, 10, 12, and 14 through 22 shall not be used in this test. Only the data points of the category “Frequency Droop (Frequency-Watt)” in Table 63 of the DNP3 app note shall be used in association with this function.

6.8.3.15 Enter service

Section 2.4.5 of the DNP3 app note identifies steps involved in enter-service configuration. For this function, step b)1) in 6.3.2 shall consist of protocol-specific steps 8 through 14, 16, and 17 identified in the DNP3 app note. Optional steps 1 through 7 and 15 shall not be used in this test. Only the data points of the category “Enter Service” in Table 63 of the DNP3 app note shall be used in association with this function.

6.8.3.16 Limit maximum active power

Section 2.6.1 of the DNP3 app note identifies the steps involved in limit maximum active power control. For this function, step b)1) in 6.3.2 shall consist of protocol-specific steps 7 and 8 identified in the DNP3 app note. Optional steps 1 through 6 shall not be used in this test. Only the data points of the category “Active Power Limit Mode” in Table 63 of the DNP3 app note shall be used in association with this function.

7. Production tests

7.1 Introduction

Production tests verify the operability of every individual DER interconnection component or system manufactured for customer use. These tests assume that equipment of the same design has met the applicable requirements of [Clause 5](#) and [Clause 6](#). These tests may be conducted as a factory test or performed as part of a *commissioning test*. If any tests from [Clause 5](#) or [Clause 6](#) have not been previously completed, they may be included in the *production test* regimen.

For any of the tests to be conducted in this clause, function settings need be recorded only once. The test record retained by the EUT manufacturer shall provide a list of final settings, if any; for EUT that do not have factory settings and require settings to be applied in the field before commissioning, the test record shall state that.

At the discretion of the manufacturers, *production tests* may use the corresponding tests from [Clause 5](#) in place of the procedures listed in this clause.

DERs shall be tested at a single set of setpoints as specified by the manufacturer. *Production tests* shall include the following as applicable:

- Overvoltage and undervoltage trip tests
- Overfrequency and underfrequency trip tests

Manufacturers having quality control methods established and monitored by a recognized *testing agency*, shall be allowed to replace the test procedures in [7.2](#) and [7.3](#) with procedures mutually agreeable between the *testing agency* and the manufacturer. These quality control procedures shall at a minimum verify trip settings and accuracy of voltage and frequency measurements. Signal injection methods shall be permitted to be used for production testing.

7.2 Response to abnormal voltage

7.2.1 Purpose

The purpose of this test is to verify that the DER interconnection component or system responds to abnormal voltage conditions as required. Trip setting shall be as specified by the manufacturer.

7.2.2 Procedure

The procedure is as follows:

- a) Connect the EUT according to the instructions and specifications provided by the manufacturer.
- b) Verify all *ac test source* parameters are at nominal operating conditions for the EUT.
- c) Set the EUT to the manufacturer's trip voltage and time settings as applicable. Verify that all of the other EUT settings are at their factory set points.
- d) Record applicable settings.

- e) Select one of the undervoltage or overvoltage protective functions for test.
- f) Adjust the *ac test source* voltage to a point beyond the trip setting under test by at least twice the MRA.⁹³ Record the rms voltage magnitude and *clearing time*.
- g) For *multiphase* units, perform this test on each phase, adjusting one phase at a time.
- h) Repeat steps e) through g) for all of the undervoltage and overvoltage protective functions.

7.2.3 Criteria

The test results are acceptable if the EUT trips in the ranges specified by the manufacturer.

7.3 Response to abnormal frequency

7.3.1 Purpose

The purpose of this test is to verify that the DER interconnection component or system responds to abnormal frequency conditions as required. Trip setting shall be as specified by the manufacturer.

7.3.2 Procedure

The procedure is as follows:

- a) Connect the EUT according to the instructions and specifications provided by the manufacturer.
- b) Verify all *ac test source* parameters are at nominal operating conditions for the EUT.
- c) Set the EUT to the manufacturer's trip frequency and time settings as applicable. Verify that all of the other EUT settings are at their factory set points.
- d) Record applicable settings.
- e) Select one of the underfrequency or overfrequency protective functions for test.
- f) Adjust the *ac test source* frequency to a point beyond the trip setting under test at least twice the MRA.⁹⁴ Record the frequency and *clearing time*.
- g) Repeat steps e) through f) for all of the underfrequency and overfrequency protective functions.

7.3.3 Criteria

The test results are acceptable if the EUT trips in the ranges specified by the manufacturer.

7.4 Documentation

The *production test* documentation shall include the production date, manufacturer's model number, serial number, functional software and firmware versions (where applicable), test results and settings. This information shall be made available upon request.

⁹³The test needs to be designed so that the EUT trips due to the selected abnormal voltage protective function and not due to another protective function of the EUT. The test design should include selection of appropriate voltage level. The trip magnitude and time settings may be verified using a single test waveform in one test or using different test waveforms in two separate tests.

⁹⁴The test needs to be designed so that the EUT trips due to the selected abnormal frequency protective function and not due to another protective function of the EUT. The test design should include selection of appropriate frequency level. The trip magnitude and time settings may be verified using a single test waveform in one test or using different test waveforms in two separate tests.

8. DER evaluations and commissioning tests

8.1 Introduction

The procedures, requirements, and criteria for the applicable test and verification methods within [Clause 8](#) are provided as recommendations, acknowledging that there is wide variation among DER installations and *area EPS* conditions. These verification requirements and test specifications are generally needed for interconnection of DERs and are typically sufficient for most installations. Specific evaluations and tests shall be performed in accordance with *area EPS operator* interconnection requirements.

Depending upon the circumstances, additional verification steps may be needed to establish confidence in DER compliance to IEEE Std 1547 requirements, or some steps within [Clause 8](#) may not be applicable or may need modification.

IEEE Std 1547-2018 defines the interconnection and interoperability requirements as well as verification process as identified in Clause 11 of that standard and summarized here, in part:

This identifies the necessary conditions that shall be verified to prove proper and reliable operation of the DER.

All DER interconnection and interoperability requirements of this standard shall be demonstrated through either type tests, production tests, DER evaluation, commissioning tests, or periodic tests or a combination of these tests and verification methods. Requirements and capabilities that are only partially verified through type testing shall be fully verified through DER evaluation and commissioning tests.

This clause further specifies at which stage in the interconnection process testing and verification shall be required. The applicable test and verification methods from this clause are required for all DERs. The results of these test and verification methods shall be formally documented.

Applicable testing and verification methods for type testing and production testing are discussed earlier in this document with the discussion of the technical requirements.

The verification requirements for DER *installation evaluation* and commissioning testing are determined by whether the DER has undergone full or partial conformance testing, and whether the *reference point of applicability* (RPA) of DER is at the PCC or at the PoC. The *area EPS operator* may also mandate particular *commissioning tests*.

8.1.1 Reference points of applicability (RPA)

The characteristics of the *local EPS* and DER shall determine the RPA, either at the PCC or PoC. Relevant clauses of IEEE Std 1547-2018 for determining the RPA and the relevant test requirements are as follows:

- 4.2 Reference points of applicability (RPA)
- 11.3 Full and partial conformance testing and verification

8.1.2 Full or partial compliance

A *DER unit* is defined as a fully compliant DER that does not require *supplemental DER devices* to meet the IEEE 1547 requirements. A *DER system* is defined as a system consists of *DER unit(s)* and

supplemental DER device(s) that is type tested as a system and installed in accordance with the DER manufacturer's instructions and that, as a whole, is fully compliant with IEEE Std 1547.

A partially compliant *DER unit* is defined as a unit that does not meet all of the IEEE 1547 requirements and requires *supplemental DER device(s)* and/or may require supplemental evaluation by the *area EPS operator* or AGIR to verify compliance to meet the requirements of IEEE Std 1547.

A *DER composite* is defined as a system that consists of partially compliant DER components and *supplemental DER device(s)*, and requires detailed *design evaluation*, installation evaluation, and *commissioning tests* to determine full compliance to IEEE 1547 requirements. *Design evaluation* of the *DER composite* system shall determine the level of verification required to verify compliance. The design and *installation evaluations* and *commissioning tests* triggered by the partial compliance are to be limited to the related requirements impacted by the supplemental device(s) used to achieve full compliance including adverse impacts of those devices on other IEEE 1547 requirements, and the DER is to be considered as meeting the unaffected requirements which have been satisfied by type testing.

Table 43 in IEEE Std 1547-2018 outlines all of the verification requirements for a full compliant *DER system* and *DER composite* with RPA at the PCC. Table 44 in IEEE Std 1547-2018 outlines all of the verification requirements for a fully compliant *DER unit* and *DER composite* with RPA at the PoC.

8.1.3 DER verification process

This subclause introduces the steps in the system verification process. Each step is described in increased detail later in [Clause 8](#).

8.1.3.1 DER *design evaluation* (desk study)

The *design evaluation* (desk study) is an evaluation during the design and interconnection review process to verify that the fully compliant DER or composite of the individual partially compliant DERs forming a system as designed meets the interconnection and interoperability requirements of IEEE Std 1547. This evaluation is usually done off-site before equipment is delivered and installed.

8.1.3.2 DER as-built *installation evaluation* (on-site)

The as-built *installation evaluation* (on-site) is an evaluation at the time of commissioning to verify that the fully compliant DER or composite of the individual partially compliant *DER units* forming a system as delivered and installed meets the interconnection and interoperability requirements of IEEE Std 1547. This evaluation does not require testing.

8.1.3.3 Basic and detailed *DER evaluation*

A basic *DER evaluation* shall be limited to verify that the DER has been designed and installed with the proper components and connections. A detailed *DER evaluation* shall include an engineering verification of the chosen components and may require modeling and simulation of the composite of the individual partially compliant DERs forming a system.

8.1.3.4 Commissioning tests and verifications

8.1.3.4.1 General

See subclause 11.2.5.1 of IEEE Std 1547-2018 for general guidance on *commissioning tests*.

Table 71 provides a summary of the high-level test and verification process.

Table 71 —Summary of tests and verifications

Test	Description
<i>Type test(s) of DER unit(s)</i>	A <i>DER unit</i> that is type tested and compliant with the standard.
<i>Type test of DER system</i>	A <i>DER system</i> that is composed of <i>DER units</i> and <i>supplemental DER devices</i> that are type tested as a system and that, as a whole, is compliant with the standard.
<i>Basic DER evaluation</i>	A basic <i>DER design evaluation</i> shall be limited to verify that the DER has been designed with the proper components and connections. A basic <i>DER as-built installation evaluation</i> shall verify that the DER has been installed with the proper components and connections and all settings are as detailed in the project documentation.
<i>Detailed DER evaluation</i>	A detailed <i>DER design evaluation</i> shall include an engineering review of the chosen components and may require modeling and simulation of the composite system. A detailed <i>DER as-built installation evaluation</i> shall verify that the DER has been installed with the proper components and connections and all settings are as detailed in the project documentation.
<i>Basic commissioning test</i>	A basic <i>commissioning test</i> may include visual inspection and an operability test on the isolation device. The basic <i>commissioning test</i> shall be determined from the <i>design evaluation</i> .
<i>Detailed commissioning test</i>	A detailed <i>commissioning test</i> shall include a basic <i>commissioning test</i> and functional tests to verify compliant system performance and interoperability of a combination of devices forming a system to verify that the devices are able to operate together as a system. The detailed <i>commissioning test</i> shall be determined from the <i>design evaluation</i> .

Figure 17 outlines the test and verification process for systems with the RPA at the PoC.

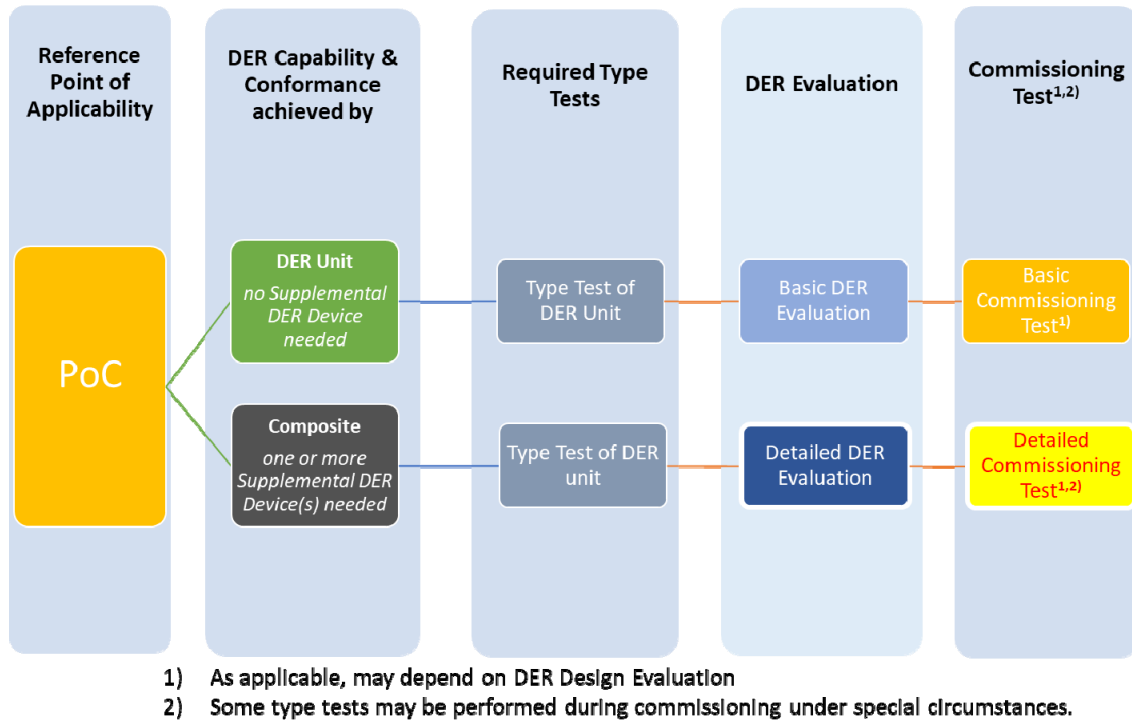

Figure 17 —Test and verification process for systems with RPA at PoC

Figure 18 outlines the test and verification process for systems with the RPA at the PCC.

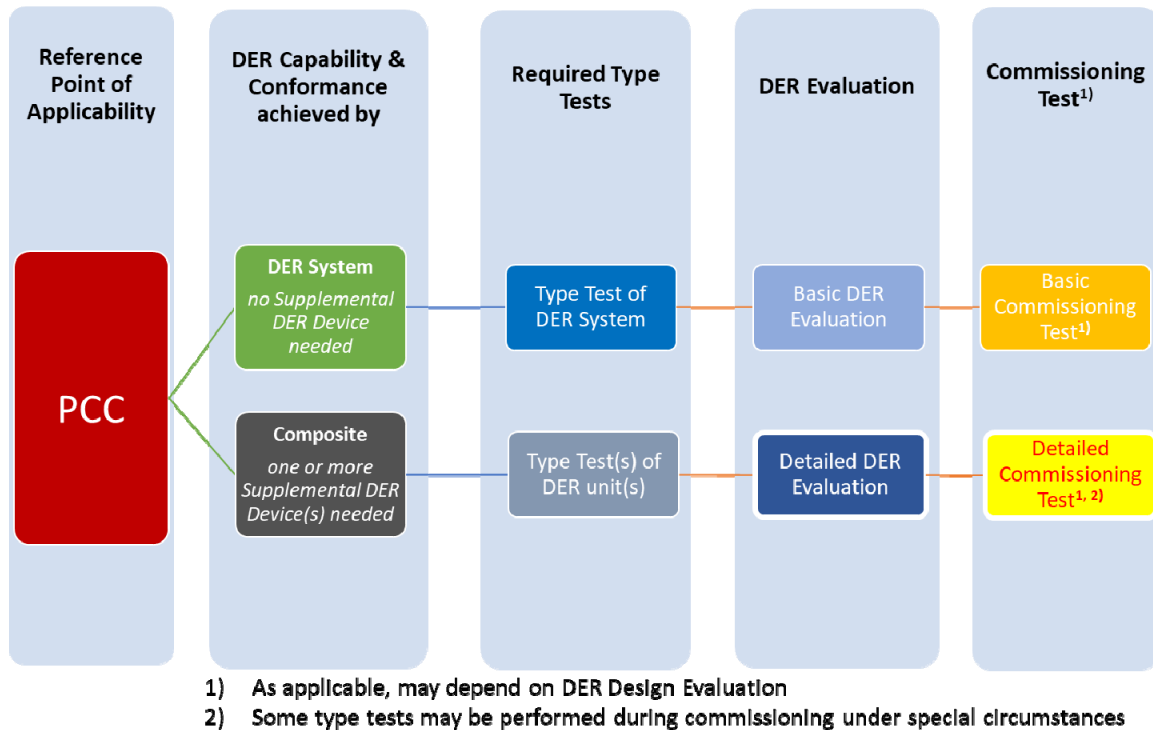

Figure 18—Test and verification process for systems with RPA at PCC

8.1.3.4.2 Basic and detailed *commissioning test*

A basic *commissioning test* may include visual inspection and the possibility of several tests of key functions of the interconnection such as an operability test on the isolation device determined by the *design evaluation*. A detailed functional *commissioning test* shall include a basic functional test and functional tests to verify the combination of devices are able to operate together as a system and meet the applicable requirements of IEEE Std 1547.

The *area EPS operator* or AGIR may impose specific requirements for commissioning testing. Normally, *commissioning test* assumes all the test preconditions such as *production tests*, *type tests*, *design evaluation*, and *installation evaluation* have been completed. The *commissioning test* should be coordinated with the *area EPS operator*. The *area EPS operator* may require the ability to witness the *commissioning test* as described in this clause or may require documentation from the equipment owner describing which tests were performed and their results.

8.1.4 Using this standard

IEEE Std 1547 identifies the steps in the verification process as follows: *design evaluation*, on-site *installation evaluation*, and *commissioning tests*:

Certain verification steps are required for all systems.

8.1.4.1 Verification required for all DERs

The following steps are required for all DER verifications:

- a) Review owner's project requirements (OPR), project specifications, and AGIR requirements for information specifically related to the *DER unit's type test* requirements, *production test* requirements, and project-specific settings and configurations.
- b) Determine the RPA for the DER per 4.2 of IEEE Std 1547-2018.
- c) Determine if the DER is eligible for exemption per 4.13 of IEEE Std 1547-2018. If the DER is determined to be exempt, note this in the *design evaluation* or interconnection agreement.
- d) Verify that the agreement between the *DER operator* and EPS operator, if required, has been executed.
- e) Verify that all settings meet requirements set by the *area EPS operator*.
- f) Verify the operating modes that will be implemented at the time of commissioning.⁹⁵
 - 1) Verify the system is capable of meeting the applicable Category I, II, or III as specified by the AGIR. Document required settings for the operation.
 - 2) Verify the system is capable of meeting the applicable Category A or B as specified by the *area EPS operator*. Document required settings for the operation.
 - 3) Record all settings for response to abnormal voltage and frequency conditions and verify compliance with AGIR requirements.
 - 4) Record all enabled voltage/power control functions and settings.
 - 5) Confirm operational coordination with EPS reclosers where applicable.
 - 6) Confirm after-trip-return-to-service operation requirements.
 - 7) Verify unintended islanding detection operation and state interval time from initiation of the *island* to cease-to-energize.
 - 8) If available, review power systems simulation and models to verify DER Characteristics were properly characterized. Include summary and source data for any engineering verification of the chosen components or modeling and simulation of the DERs forming a system.
- g) For requirements that are supported by a protection study, confirm DER settings and connection configuration with the study.
- h) If applicable, describe each interoperable function and packet of data to be communicated. Each description should include all particulars to confirm compliance with the EPS Interconnection Application/Agreement.
- i) Considering all of the above, list the elements of the DER functionality that must be verified during commissioning.

8.1.4.1.1 Corrective actions and exceptions

After the *design evaluation* is complete, any non-compliance, and/or recommendations for further verification should be documented and used in the remaining steps of the verification process:

- a) Identify technical requirements that should be verified during the *commissioning test*. This information should be communicated to all stakeholders after the *design evaluation*.
- b) Adjustments to the settings of the *area EPS* protection systems or changes to the DER interconnection parameters may be needed to maintain proper fault *detection time* and protective relaying coordination intervals acceptable to the *area EPS operator*.
- c) Identify any system modifications or corrective actions that should be completed prior to commissioning.

⁹⁵The *DER unit* or system must have the capability of performing the modes required by IEEE Std 1547. The specified modes are selected for initial utilization.

8.1.4.1.2 Specific issues and circumstances for basic DER *design evaluation*

The AGIR may specify the level of functional testing and verification based on DER size or EPS conditions.

If the DER installation is incomplete due to the following causes, the resulting actions are recommended:

- a) DER design, including specification of all components and system configuration are not complete—Defer DER *design evaluation* until the DER design is complete.
- b) EPS source connection not available—Evaluate the option for testing functionality during commissioning using a simulated EPS Source
- c) *Local EPS* internal systems not complete—Evaluate the impact and consider the need for functionality testing during commissioning using simulated load.
- d) The system should be substantially complete by a predetermined date—Consider functional testing using items b) and c).

Additionally, if the EPS operator determines there is sufficient experience and evidence of successful performance with a previously or commonly installed *DER unit* or system configuration, the *area EPS operator* may waive the requirement for an *installation evaluation*

8.1.4.2 Verification by system type—PoC and PCC requirements tables

The remainder of [Clause 8](#) discusses *design evaluation*, *installation evaluation*, and *commissioning tests* for the following combinations of *reference point of applicability* and conformance method:

- *DER unit* with RPA at PoC (8.2)⁹⁶
- *DER systems* with RPA at PoC (8.2)⁹⁶
- *DER composite* with RPA at PoC (8.3)⁹⁷
- *DER system* with RPA at PCC (8.4)
- *DER units* with RPA at PCC and with effective impedance between PoC and PCC greater than 0.5% on DER rated voltage and apparent power base of the DER (8.4)
- *DER composite* with RPA at PCC (8.5)

The “Verification Summary for PoC/PCC” requirement tables identify the *design evaluations*, *installation evaluations*, and *commissioning tests* that need to be done to meet the relevant IEEE 1547 test requirements that are listed in the rows of the table. The PoC and PCC requirements tables can be found in the appropriate subclause for the RPA of the DER (8.2, 8.3, 8.4, or 8.5). The subclauses of IEEE Std 1547.1 that describe the evaluations and tests are also shown in each table.

Use these tables to identify the pertinent evaluations and tests that must be completed for the applicable IEEE 1547 requirement as defined by the appropriate table and relevant IEEE Std 1547 subclauses as referenced in the table.

- a) Choose the appropriate table for the DER application:
 - 1) [Table 72](#) for PoC units: This table identifies the *design evaluations*, *installation evaluations*, and *commissioning tests* required for *DER unit(s)* whose RPA is PoC and supplemental equipment IS NOT needed for the DER to meet IEEE 1547 requirements. This table also applies to situations where the PoC and PCC are at the same location or are separated by an

⁹⁶IEEE Std 1547-2018 states that for scenarios where the zero-sequence continuity between the PCC and PoC is not maintained, the RPA for performance requirements in subclauses 6.2 and 6.4 of IEEE Std 1547-2018 should be a point between, or including, the PoC and PCC that is appropriate to detect the abnormal voltage conditions.

⁹⁷Examples: changed transformer impedance or connection, changed cable length or type.

effective impedance of less than 0.5% on the DER rated voltage and apparent power base, and supplemental equipment is not needed.

- 2) **Table 73** for PoC composites: This table identifies the *design evaluations*, *installation evaluations*, and *commissioning tests* required for *DER unit(s)* whose RPA is PoC and supplemental equipment IS needed for the DER to meet IEEE 1547 requirements.
- 3) **Table 74** for PCC systems: This table identifies the *design evaluations*, *installation evaluations*, and *commissioning tests* required for *DER unit(s)* and type-tested *DER system(s)* whose RPA is PCC and for which supplemental equipment IS NOT needed for the DER to meet IEEE 1547 requirements.
- 4) **Table 75** for PCC composites: This table identifies the *design evaluations*, *installation evaluations*, and *commissioning tests* required for *DER units* whose RPA is PCC and supplemental equipment IS needed for the DER to meet IEEE 1547 requirements. This table is also to be used for type-tested *DER systems* that differ from the DER manufacturer's instructions.⁹⁶
 - b) The requirements of IEEE Std 1547 that need to be evaluated are in the first two columns of the table.
 - c) Relevant *design evaluations* are in the "DE1," "DE2," "DE3," and "DE4" columns. The second row identifies the pertinent subclauses in this document for each *design evaluation*. An R in any box in the "DEx" columns identifies a required *design evaluation* to verify the relevant IEEE 1547 requirements.
 - d) Relevant *installation evaluations* are in the "IE1," "IE2," and "IE3" columns. The second row identifies the pertinent subclauses in this document for each *installation evaluation*. An R in any box in the "IEx" columns identifies a required evaluation to verify the relevant IEEE 1547 requirement.
 - e) Relevant *commissioning tests* are in the "CT1," "CT2," "CT3," "CT4," "CT5," and "CT6" columns. The second row identifies the pertinent subclauses in this document for each *commissioning test*. An R in any box in the "CTx" columns identifies a required *commissioning test* to confirm the relevant IEEE 1547 requirement. A D in any box in the "CTx" columns identifies a *commissioning test* may be needed to confirm the relevant IEEE 1547 requirement. In this case, the need for a *commissioning test* is dependent on the results of the *design evaluation*. Guidelines in the relevant subclauses of this document provide guidance for whether a *commissioning test* is required.

8.2 PoC-Unit: Basic *DER evaluations* and *commissioning tests* for *DER units* and *DER systems* with RPA at PoC

The list of *design evaluations*, *installation evaluations* and *commissioning tests* outlined in this subclause are provided as a recommendation. Specific evaluations and tests shall be performed in accordance with *area EPS operator* interconnection requirements.

Table 72 summarizes the relevant technical requirements that should be verified and indicates with an *R* that the step is required to be verified by the evaluation or test in the applicable column. Note that the requirement for the *commissioning test* by a *D* in the column is determined during the *design evaluation*.

This clause applies to *DER units* and *DER systems* that have been type tested for full compliance with the requirements of IEEE Std 1547 at the PoC. The *DER units* and *DER systems* shall be installed in accordance with the manufacturer's instructions.

Table 72—Verification Summary for PoC units

Subclause in IEEE Std 1547-2018		Subclause in IEEE Std 1547.1							
Subclause number	Title	DE1 – Confirm pertinent type test and production test requirements met	DE2 – Confirm with protection and impact study	IE1 – Verify installation matches design evaluation	IE2 – Verify installation settings	CT1 – On-off test	CT2 – Verify synchronization	CT3 – Voltage and frequency tests	CT4 – Power quality tests
		8.2.1.1	8.2.1.2	8.2.2.1	8.2.2.2	8.2.3.1	8.2.3.2	8.2.3.3	8.2.3.4
4.2	Reference points of applicability	R	NR	R	NR	NR	NR	NR	NR
4.3	Applicable voltages	R	NR	R	NR	NR	NR	NR	NR
4.9	Inadvertent energization of the <i>area EPS</i>	NR ^a	NR	R	R	D	NR	NR	NR
4.10.3	Performance During Enter Service	R	NR	R	NR	D	NR	NR	NR
4.10.4	Synchronization	R	NR	R	NR	NR	D	NR	NR
4.12	Integration with <i>area EPS</i> grounding	R	R	R	NR	NR	NR	NR	NR
5.4.2	Voltage-Active Power Mode	R	NR	NR	R	NR	NR	NR	NR
6.2	Area EPS Faults and open phase conditions	R	R	NR	NR	NR ^b	NR	NR	NR
6.3	Area EPS reclosing coordination	R	R	NR	NR	NR	NR	NR	NR
6.4.1	Mandatory voltage tripping requirements	R	R	NR	R	NR	NR	NR	NR
6.4.2.3.3	Low-voltage ride-through performance	R	R	NR	NR	NR	NR	D	NR
6.5.1	Mandatory frequency tripping requirements	R	R	NR	R	NR	NR	D	NR
7.2.2	Rapid voltage changes (RVC)	NR	R	NR	NR	NR	NR	NR	D
7.2.3	Flicker	NR	R	NR	NR	NR	NR	NR	D
7.4	Limitation of overvoltage contribution	NR	R	R	NR	NR	NR	NR	D
8.1	Unintentional islanding	NR ^a	NR ^a	NR ^c	NR ^c	NR ^b	NR	NR	NR
9.2	Distribution secondary grid networks	NR	R	R	NR	D	D	NR	NR
9.3	Distribution secondary spot networks	NR	R	R	NR	D	D	NR	NR

Legend: R = required evaluation or test, D = test dependent on *design evaluation*, NR = no requirement, Shaded = no requirement in IEEE Std 1547-2018.

^a IEEE Std 1547-2018 identifies this test as not required (NR). It is recommended to consider a *design evaluation*.

^b IEEE Std 1547-2018 identifies this test as not required (NR). It is recommended to consider this *commissioning test* depending on *design evaluation*.

^c IEEE Std 1547-2018 identifies this test as not required (NR). It is recommended to consider an *installation evaluation*.

8.2.1 Basic DER *design evaluation* for PoC units

These procedures are in addition to the steps described in 8.1.4.1 that are required for all systems. The following should be considered:

The basic DER *design evaluation* is done after equipment is selected and integration methods are agreed to but before the installation of equipment on site. During this step, consideration should be given to EPS operator interconnection practices, regulatory requirements, local code, and existing power systems models of the distribution circuit. Additionally, the *commissioning tests* required for the *DER unit* are identified during this step.

NOTE—It is recommended that this step occur early in a project so that the commissioning requirements can be included in the project plan.

8.2.1.1 *Design evaluation* DE1: Confirm pertinent *type test* and *production test* requirements are met

8.2.1.1.1 Purpose

The purpose of this evaluation is to confirm that the *type tests* and *production test* requirements are met by the *DER unit*. Additionally, it is to verify that the design and installation is consistent with the conditions for having the RPA at the PoC. Confirmation of these requirements shall be achieved by reviewing project documentation, certification, pertinent regulatory requirements, and other pertinent documentation.

8.2.1.1.2 Requirements

This evaluation shall be performed when the *DER unit* has been selected for the application. The *type test* results summary document for the *DER unit* issued by the *testing agency* shall be used for the evaluation. The *DER unit* datasheet shall be used to determine compliance to the system operation conditions.

8.2.1.1.3 Procedure

Review the design documentation. For systems with RPA of PoC⁹⁸ and compliant as units, consider the following steps:

- a) Verify that PoC unit has been approved for the applicable requirements of IEEE Std 1547 as shown in Table 72.
- b) Verify that the design and installation is consistent with the conditions for having the RPA at the PoC.
- c) Verify the implementation of unintentional or intentional islanding method as required by the *area EPS operator*.^{99, 100}
- d) Record the results of analysis and identify requirements that need to be confirmed by *commissioning tests*.

⁹⁸For the case where the zero-sequence continuity is not maintained between the PoC and PCC, subclauses 6.2 and 6.4 of IEEE Std 1547-2018 need to be complied with at the PCC, per IEEE Std 1547-2018.

⁹⁹Some unintentional islanding methods that were type tested may only be partially compliant and when installed, and may require specific implementation of field devices. In this scenario, the end-to-end implementation of the unintentional islanding method should be evaluated and may require a *commissioning test*.

¹⁰⁰Additional DER integration issues may need to be evaluated for all *island* detection methods, including interactions of combinations of islanding detection methods on the same *area EPS*.

8.2.1.1.4 Criteria

The evaluation shall verify that pertinent requirements for the categories are met. Results of this evaluation shall be documented, highlighting acceptance or failure and any corrective actions needed. This evaluation may result in the need for further confirmation by *commissioning tests*. The items that require further confirmation by *commissioning tests* should be clearly identified along with determination of what needs to be tested to confirm that the *DER unit* meets the requirements.

Failure of the documentation and inspection to demonstrate the required capability may generate a requirement for 8.2.3.1 [*Commissioning tests* CT1 (On/Off) in Table 72] and/or 8.2.3.2 [CT2 (Synchronization) in Table 72)], as determined by the EPS operator.

The basic criteria that should be considered and documented as part of the verification process are listed in 8.1.4.1.

8.2.1.2 Design evaluation DE2: Confirm with protection and impact study

8.2.1.2.1 Purpose

If a protection and/or impact study is required, the purpose of this evaluation is to confirm that the protection requirements, ride through capability and grounding requirements are met by the *DER unit* and to provide the *area EPS operator* with information necessary to evaluate the impact of the DER connection onto the *area EPS*. The system model and fault current review, along with other protection and impact study tools, are used to confirm whether voltage deviations meet IEEE 1547 requirements.

8.2.1.2.2 Requirements

This evaluation shall be performed once the *DER unit* has been selected. *DER unit* protection settings shall be coordinated once results from the protection study are available.

8.2.1.2.3 Procedure

The procedure is as follows:

- a) For inverter technologies, provide oscillographic representation of the voltage and current data for all phases measured during fault current characterization type testing. See 5.18.1 for reference. Sequence impedance characteristics of the test source used during fault current characterization *type tests* shall be provided. For synchronous and induction generators, appropriate parameters specified in 5.18.2.1, 5.18.2.2, or 5.18.2.3 shall be provided.
- b) Confirm that the *DER unit* interconnects according to integration with *area EPS* grounding requirement in 4.12 in IEEE Std 1547-2018.
- c) Confirm that restore output settings coordinate with *area EPS* reclosing as required by 6.3 in IEEE Std 1547-2018 and that the DER ceases to energize and trips during *area EPS* short circuit faults and upon open phase instances as required by 6.2.1 and 6.2.2 of IEEE Std 1547-2018, respectively. Confirm trip settings match those in the protection study.¹⁰¹
- d) Confirm that low-voltage ride-through capability meets requirements in 6.4.2.3.3¹⁰² in IEEE Std 1547-2018. Determine if *commissioning tests* are required to confirm.

¹⁰¹The protection settings should be as agreed upon with the *area EPS operator*.

¹⁰²For the case where the zero-sequence continuity is not maintained between the PoC and PCC, subclauses 6.2 and 6.4 of IEEE Std 1547-2018 need to be complied with at the PCC.

- e) Confirm voltage trip settings and frequency tripping settings match those in the protection study and meet requirements in 6.4.1 and 6.5.1 in IEEE Std 1547-2018.^{103, 104}
- f) Confirm that the fault current contribution from the *DER unit* does not adversely affect the function and operation of the *area EPS* protection equipment.
- g) If impact study has been performed, verify that solutions for each of the following have been implemented:
 - 1) Rapid voltage changes (RVC) (7.2.2 in IEEE Std 1547-2018). Determine if *commissioning tests* are required to confirm compliance.
 - 2) Flicker (7.2.3 in IEEE Std 1547-2018). Determine if *commissioning tests* are required to confirm compliance.
 - 3) Limitation of overvoltage contribution (7.4 in IEEE Std 1547-2018).
- h) If the GFOV and LROV tests were performed on the *DER unit*, the results obtained from that *type tests* can be used to evaluate the effect of the DER on the *area EPS* overvoltage limits as defined in 7.4.1 of IEEE Std 1547-2018.¹⁰⁵
- i) If the DER is connected to a secondary grid or spot network, confirm that the DER is implemented as required in Clause 9 of IEEE Std 1547-2018 and will not cause misoperation of any network protector(s) or exceed any network protector rating.

8.2.1.2.4 Criteria

Design evaluation DE2 shall confirm DER settings and connection configuration with the protection and/or impact study on the *area EPS* system. As a result of the protection study, the *area EPS operator* may specify other voltage and *clearing time* trip settings within the range of allowable settings. Adjustments to the settings of the *area EPS* protection systems or changes to the DER interconnection parameters may be needed to maintain proper fault *detection time* and protective relaying coordination intervals acceptable to the *area EPS operator*.

Failure of the documentation and inspection to demonstrate the required capability may generate a requirement for 8.2.3.3 [*Commissioning test* CT3 (Voltage and Frequency) in Table 72], and/or 8.2.3.4 [CT4 (Power Quality) in Table 72], as determined by the EPS operator.

8.2.2 Basic DER *installation evaluation* for PoC units

Basic DER *installation evaluation* is performed on-site after equipment is delivered and put in place. This is an evaluation prior to or at the time of commissioning to verify that the *DER unit* as delivered and installed meets the interconnection and interoperability requirements of IEEE Std 1547. The primary input to this is the *design evaluation* documentation and a physical inspection of the system, as installed.

Results of this evaluation shall be documented, highlighting acceptance or failure and any corrective actions needed. This evaluation may result in the need for further actions prior to *commissioning tests*.

¹⁰³For the case where the zero-sequence continuity is not maintained between the PoC and PCC, subclauses 6.2 and 6.4 of IEEE Std 1547-2018 need to be complied with at the PCC.

¹⁰⁴The voltage and frequency trip protection settings should be as agreed upon with the *area EPS operator*.

¹⁰⁵The results of the tests may inform the system design of the need for supplemental grounding sources in certain applications.

8.2.2.1 Installation evaluation IE1: Verify installation matches design evaluation

8.2.2.1.1 Purpose

The purpose of this evaluation is to verify that the equipment installed is that evaluated under the DER *design evaluation* and has been installed correctly with the correct equipment. The evaluation shall determine whether the *DER unit* complies with the pertinent IEEE 1547 requirements identified in this subclause by verifying that the specified equipment with correct parameters and configurations has been installed.

In addition, any corrective actions identified in the DER *design evaluation* shall be verified as complete.

8.2.2.1.2 Requirements

This *installation evaluation* shall be performed when the *DER unit* has been installed and prior to commissioning.

8.2.2.1.3 Procedure

The procedure is as follows:

- a) Review the results of the DER *design evaluation* and project documentation for information specifically related to *DER unit's* project-specific settings and configurations.
- b) Confirm that the actual installation is complete.
- c) Confirm that equipment on site is that which was used in the basic DER *design evaluation* and matches project documentation.
 - 1) This is done by confirming that nameplate data of installed equipment matches that which was identified in the *design evaluation* and project documentation.
 - 2) Nameplate data includes model number, serial number, configuration information, and other parameters.
- d) Confirm system installation is in accordance with the electrical design as submitted with the application for interconnection.
- e) Confirm system grounding is in compliance with the governing interconnection agreement. Refer to IEEE Std C62.92.1 for definitions of grounding and to IEEE Std C62.92.6 for guidance in the case of inverter DER.¹⁰⁶
- f) Visually inspect and verify operability of the isolation device, as specified in the governing interconnection agreement.
- g) Any corrective action identified in the design review should be checked for completion. Results of this evaluation shall be documented, highlighting acceptance or failure and any corrective actions needed should be highlighted.

8.2.2.1.4 Criteria

Confirmation of these requirements shall be achieved by reviewing the results of the *design evaluation* and inspecting the *DER unit* as installed to verify that the installation and configuration matches that of the project documentation and the design review.

¹⁰⁶Additional consideration may be given to cases that may have not been considered in IEEE Std C62.92.6.

Failure of the documentation and inspection to demonstrate that the installation matches the *design evaluation* may result in corrective actions needing completion before commissioning.

8.2.2.2 Installation evaluation IE2: Verify installation settings

8.2.2.2.1 Purpose

The purpose of this evaluation is to verify that equipment has required settings as agreed upon by the *DER operator* and the *area EPS operator*.

8.2.2.2.2 Requirements

This *installation evaluation* shall be performed when the *DER unit* installation is complete and the control system of the *DER unit* can be energized.

8.2.2.2.3 Procedure

The procedure is as follows:

- a) Review the results of the *design evaluation* and project documentation for information specifically related to *DER unit's* project-specific settings.
- b) Verify correct installation settings by identifying settings in the *DER unit* related to the interconnection as defined for DER *design evaluation* DE2 [8.2.1.2.3 d) and e)]. Compare settings with the manufacturer's production report.
- c) Verify all settings required by the *area EPS operator*.
- d) Any corrective action identified in the design review should be checked for completion. Results of this evaluation shall be documented, highlighting acceptance or failure and any corrective actions needed should be highlighted.

8.2.2.2.4 Criteria

The evaluation shall determine whether the *DER unit* complies with the pertinent requirements of IEEE Std 1547 as identified in this subclause by verifying that the actual settings in the installed equipment match the settings provided in project documentation.

Failure of the evaluation to demonstrate that the installation matches the *design evaluation* may result in corrective actions needing completion before commissioning.

8.2.3 Basic DER commissioning tests for PoC units

Basic *commissioning tests* are performed after the equipment is installed. The required testing is determined by the basic *design evaluation* and basic *installation evaluation*.

Commissioning tests determined in the basic *design evaluation* and basic *installation evaluation* documentation are performed during commissioning.

In addition to the tests determined by the above verification steps, there may be requirements for communication testing and permissive signal testing. This is determined by the *area EPS operator*. The functionality of DER voltage and frequency tripping, and compliance with cease to energize requirements,

shall be verified. Where it is impractical to test the shall-trip settings using actual voltage and frequency adjustment, the use of signal injection method shall be allowed.

8.2.3.1 Commissioning Test CT1: On-off test

8.2.3.1.1 Purpose

The purpose of this test is to confirm, if required by the *DER evaluation*, that the enter service requirement and any secondary grid or spot network requirements are able to be met by the *DER unit* as installed.¹⁰⁷ The purpose of this test is to evaluate the impact of *DER unit* energization and operation on the *area EPS*. The *DER unit* shall be energized, operated up to maximum available capacity, and go through planned and unplanned shutdown sequences.¹⁰⁸

8.2.3.1.2 Requirements

This test shall be performed when the *DER unit* has passed deenergized and pre-energization checks and has been approved for energization and operation at the specified operating modes. *The area EPS operator may require representation during initial energization and during the testing of the DER.*

8.2.3.1.3 Procedure

The need for *commissioning tests* for PoC units is summarized in the “CT1” column in [Table 72](#). The need for any *commissioning test* for PoC units is determined in the *design evaluation*.

- a) Any corrective action identified in the *installation evaluation* should be checked for completion. Results of this evaluation shall be documented, highlighting any acceptance or failure and any corrective actions needed,
- b) With the *DER unit* in the OFF state, bring the DER online. The *DER unit* shall be set to the specified operating mode, active, reactive power or power factor setpoints. Confirm that the DER starts to come online (delivering power into the *area EPS*) or makes connection to the *area EPS* when the DER voltage and frequency are within range specified in Table 4 or Table 5 of IEEE Std 1547-2018, and permit service is enabled. During the start-up of the *DER unit*, observe the *area EPS* voltage response (transient and steady-state), any intentional delay and power ramping until the DER reaches a steady-state operation. Simulate a disconnect and reconnect condition and observe the return to service of the DER. This may be achieved by manually triggering a disconnect of the DER from the *area EPS* using a device other than the interconnection device that provides the cease-to-energize function or creating a temporary abnormal condition by adjusting the window of voltage operation, for example, to cause a disconnect, or by other means. Once the DER is disconnected, the parameter used to cause the disconnect, is reversed to allow for reconnect or return to service.
- c) Operate the DER interconnected with the *area EPS* at an output power level at available capacity at the time of testing.

¹⁰⁷This test does not completely confirm the requirement but, along with the *type test*, creates a high probability the *DER unit* will meet the requirement.

¹⁰⁸For installations that are dependent on input source availability such as solar and wind installations, the *DER unit* needs to be operated up to the available capacity at the time of the test or as agreed upon with *area EPS operator*.

- d) Disconnect all ungrounded phases from the *area EPS* simultaneously using a device other than the interconnection component that provides the cease-to-energize function.
 - 1) Verify that the *DER unit* ceases to energize the output terminals connected to the *area EPS* compliant to 6.2.2 of IEEE Std 1547-2018.
 - 2) After a convenient period, reclose the selected disconnect.
- e) For multi-phase DER, disconnect one ungrounded phase from the *area EPS* using a device other than the interconnection component that provides the cease-to-energize function. This open phase shall be performed at the PoC with no significant load, transformers, or reactive compensation devices connected between the open point and the PoC.
 - 1) Verify that the *DER unit* ceases to energize the output terminals connected to the *area EPS* compliant to 6.2.2 of IEEE Std 1547-2018.
 - 2) After a convenient period, reclose the selected disconnect.
- f) Verify that the *DER unit* does not enter service when permit service setting is disabled.
- g) Verify that the *DER unit* does enter service when permit is “enabled” and the applicable voltages and frequency are within the acceptable ranges.
- h) Verify that the *DER unit* does not reenergize output terminals connected to the *area EPS* for the required Enter Service time delay after the *area EPS* steady-state voltage and frequency are returned to acceptable ranges as in Table 4 of IEEE Std 1547-2018.

8.2.3.1.4 Criteria

Observe the *area EPS* response and DER response and unit stability. Review observation with *area EPS operator* and perform any adjustment to operating parameters/setpoints in coordination with *area EPS operator* as necessary. Report test data that indicate that requirements in 8.2.3.1.3 f), g), and h), are satisfactorily demonstrated.

Results of a successful test shall be documented and indicate agreement between the *DER operator* and EPS operator.

Results of an unsuccessful test should document agreed-upon corrective actions and indicate which *design evaluation* and or *installation evaluation* steps are required. Test shall be repeated until satisfactory results are achieved.

8.2.3.2 Commissioning Test CT2: Verify synchronization

8.2.3.2.1 Purpose

The purpose of this test is to verify that the *DER unit* properly synchronizes with the *area EPS* without causing problems impacting EPS functionality under normal operating conditions.

8.2.3.2.2 Requirements

This test shall be performed when the *DER unit* has passed deenergized and pre-energization checks and has been approved for energization and operation at the specified operating modes.

8.2.3.2.3 Procedure

The synchronization *commissioning tests* for PoC units is summarized in the “CT2” column in [Table 72](#) and the need for any *commissioning test* for PoC units is determined in the *design evaluation*.

- a) On three phase systems, check the phase rotation of both the *area EPS* and DER to verify that they are compatible as installed. Record phase rotation.
- b) If synchronizing relay is used, test it to verify that the interconnection circuit breaker does not close when voltage and frequency are outside specified design limits.

8.2.3.2.4 Criteria

Synchronous DERs shall meet the requirements in Table 5 of IEEE Std 1547-2018, which specifies the allowable frequency difference, voltage difference, and phase angle difference depending on the aggregate rating of the DER.

The DER shall parallel with the *area EPS* without causing step changes in the rms voltage at the PCC exceeding 3% of nominal when the PCC is at medium voltage, or exceeding 5% of nominal when the PCC is at low voltage.

Results of a successful test shall be documented and indicate agreement between a *DER operator* and EPS operator.

Results of an unsuccessful test should document agreed-upon corrective actions and indicate which *design evaluation* and or *installation evaluation* steps are required. The test shall be repeated until satisfactory results are achieved.

8.2.3.3 Commissioning Test CT3: Voltage and frequency tests

8.2.3.3.1 Purpose

The purpose of this test is to verify the *DER unit* ceases to energize when there are undervoltage, overvoltage, underfrequency or overfrequency events. The test must meet the specified magnitude and *clearing time* as specified in IEEE Std 1547 and as specified by the AGIR.

In addition, the voltage and frequency tests must demonstrate Category B DER is actively limiting the DER maximum active power as a function of the voltage following a voltage-active power piecewise linear characteristic.

8.2.3.3.2 Requirements

This test shall be performed when the *DER unit* has passed deenergized and pre-energization checks and has been approved for energization and operation at the specified operating modes. *DER unit/system* has achieved stable operation at the specified operating conditions. The *DER installation evaluation* shall verify the installation and the settings required by the AGIR/*area EPS operator* for the trip timing tests.

8.2.3.3.3 Procedure

The need for *commissioning tests* for PoC units is summarized in the “CT3” column in [Table 72](#). Tests shall be performed as required by the *area EPS operator* with details determined by mutual agreement between the *DER operator* and *area EPS operator*. The tests for DER responses to abnormal *area EPS*

voltage and frequency conditions are typically performed as *type tests* due to complication of performing abnormal voltage and frequency tests in the field. *Design evaluation* is to have been performed prior to commissioning for the purpose of evaluating conformance of the *DER composite* to the *area EPS* abnormal voltage and frequency requirements and settings coordination. *Signal injection test methods* may be considered if the *DER unit* has provisions for this method.

8.2.3.3.4 Criteria

Voltage and frequency tests shall meet the limits in IEEE Std 1547. The characteristic shall be configured in accordance with the default parameter values specified in Table 10 of IEEE Std 1547-2018 for the given DER normal operating performance category.

The tests must also demonstrate that the DER meets the *clearing times* indicated for abnormal operating performance in IEEE Std 1547-2018 (see Table 11 for Category I, Table 12 for Category II, or Table 13 for Category III). Unless specified otherwise by the *area EPS operator*, default settings shall be used.

8.2.3.4 Commissioning Test CT4: Power quality tests

8.2.3.4.1 Purpose

Test cases and procedures shall be determined in agreement with the *area EPS operator* and may include evaluation at various conditions. These conditions may include *DER unit* startup, disconnection and shutdown, operation over the full active and reactive power output range of the DER, and external conditions such as natural variations in the input power or energy source, and operation of nearby facilities. Any of the power quality tests in the field shall be conducted if any field operational and performance issues arise during *commissioning tests*, determined required from the *design evaluation* and if required by the *area EPS operator*. This does not preclude the potential for power quality tests after commissioning is complete.

The performance of the *DER unit* for power quality may be continuously observed by the *area EPS operator*.

8.2.3.4.2 Requirements

This test shall be performed when the *DER system* has passed deenergized and pre-energization checkouts and has been approved for energization and operation at the specified operating modes. The *area EPS operator* may require representation during initial energization and during the testing of the *DER system*.

The measurement equipment used for power quality tests shall be compliant with IEC 61000-4-30 Class A.

8.2.3.4.3 Procedure

The description outlined in this subclause are recommended actions. Tests shall be performed if power quality issues arise during *commissioning tests* or as required by and agreed with the *area EPS operator*. Detail test procedures shall be developed in coordination with the DER designer and equipment manufacturer.

- a) The power quality requirements shall be measured and met at the PCC except for dc injection and current distortion, which may be met at the RPA. Connect the measurement equipment, per the previous sentence, at the PCC or RPA. The measurement equipment shall be capable

of measuring ac, dc, rms, instantaneous and harmonic content of the voltages, currents, and frequency. A flicker meter may be used to measure any flicker contribution.

- b) Once the setup of measurement devices is complete, perform measurement of the *DER unit* operated under the following conditions:
 - 1) During start-up of the *DER unit*, energize (close in) the step-up transformers. Observe impact on the energization in-rush current to the *area EPS*.
 - 2) Turn-on *DER unit* and sweep the active and reactive power from 0 to available capacity at time of test.
 - 3) Perform a disconnect event that causes a step change in power delivery (not a soft shutdown, i.e., ramp down of power). Observe impact to the *area EPS*.
- c) Observe power quality of *area EPS* over a duration of time to capture nominal operating condition of the *DER unit*. The conditions would include, but not limited to, cloud coverage for solar *DER unit*, operation of other generation and load sources connected to the *area EPS*.

8.2.3.4.4 Criteria

Since this is a verification of a type tested system, the demonstration of capability does not need to reproduce *type test* data, but to show that the system is within required limits, as installed. The above procedure may be modified by a documented agreement between the *DER operator* and EPS operator.

8.3 PoC-Composite: Detailed *DER evaluations and commissioning tests for DER composite with RPA at PoC*

This subclause describes the detailed verification process for a system that has the RPA at the PoC and is partially compliant. (Composite systems require additional devices.)

The list of *design evaluations, installation evaluations and commissioning tests* outlined in this subclause are provided as a recommendation. Specific evaluations and tests shall be performed in accordance with *area EPS operator* interconnection requirements.

[Table 73](#) summarizes the relevant technical requirements that should be verified and indicates with an *R* that the step is required to be verified by the evaluation or test in the applicable column.

Table 73—Verification Summary for PoC composites

Subclause in IEEE Std 1547-2018		Subclause in IEEE Std 1547.1											
Subclause number	Title	DE1 – Confirm pertinent type test and production test requirements are met	DE2 – Confirm with protection and impact study	DE3 – System design review	IE1 – Verify installation matches design evaluation	IE2 – Verify system settings	IE3 – Verify state of system	CT1 – On-off test	CT2 – Reactive power capability and control verification	CT3 – Voltage and frequency tests	CT4 – Power quality tests	CT5 – Interoperability tests	CT6 – Islanding Test
		8.3.1.1	8.3.1.2	8.3.1.3	8.3.2.1	8.3.2.2	8.3.2.3	8.3.3.1	8.3.3.2	8.3.3.3	8.3.3.4	8.3.3.5	8.3.3.6
4.2	Reference points of applicability	R	NR	R	R	NR	NR	NR	NR	NR	NR	NR	NR
4.3	Applicable voltages	R	NR	R	R	NR	NR	NR	NR	NR	NR	NR	NR
4.4	Measurement accuracy	R	NR	R	R	NR	NR	NR	NR	NR	NR	NR	NR
4.5	Cease-to-energize performance requirement	R	NR	R	NR	R	NR	D	NR	NR	NR	NR	NR
4.6.1	Capability to disable permit service	R	NR	R	R	R	NR	D	NR	NR	NR	NR	NR
4.6.2	Capability to limit active power	R	NR	R	R	NR	NR	D	NR	NR	NR	NR	NR
4.6.3	Execution of mode or parameter changes	R	NR	R	R	NR	NR	NR	D	NR	NR	NR	NR
4.7	Prioritization of DER responses and execution of mode or parameter changes	R	NR	R	R	NR	NR	D	D	D	NR	NR	NR
4.8	Isolation device	NR	NR	NR	R	NR	NR	D	NR	NR	NR	NR	NR
4.9	Inadvertent energization of the area EPS	R	NR	R	NR	NR	R	D	NR	NR	NR	NR	NR
4.10.2	Enter service criteria	R	NR	R	R	R	NR	D	NR	NR	NR	NR	NR
4.10.3	Performance during entering service	R	NR	R	NR	R	NR	D	NR	NR	NR	NR	NR
4.10.4	Synchronization	R	NR	R	R	NR	NR	D	NR	NR	NR	NR	NR
4.12	Integration with area EPS grounding	R	R	R	R	NR	NR	NR	NR	NR	NR	NR	NR
5.2	Reactive power capability of the DER	R	NR	R	R	NR	NR	NR	NR ^a	NR	NR	NR	NR
5.3.2	Constant power factor mode	R	NR	R	NR	R	NR	NR	R	NR	NR	NR	NR
5.3.3	Voltage-reactive power (volt-var) mode	R	NR	R	NR	R	NR	NR	R	NR	NR	NR	NR
5.3.4	Active power-reactive power (watt-var or P-Q) mode	R	NR	R	NR	R	NR	NR	R	NR	NR	NR	NR
5.3.5	Constant reactive power mode	R	NR	R	NR	R	NR	NR	R	NR	NR	NR	NR

Table continues

Subclause in IEEE Std 1547-2018		Subclause in IEEE Std 1547.1											
Subclause number	Title	DE1 – Confirm pertinent type test and production test requirements are met	DE2 – Confirm with protection and impact study	DE3 – System design review	IE1 – Verify installation matches design evaluation	IE2 – Verify system settings	IE3 – Verify state of system	CT1 – On-off test	CT2 – Reactive power capability and control verification	CT3 – Voltage and frequency tests	CT4 – Power quality tests	CT5 – Interoperability tests	CT6 – Islanding Test
		8.3.1.1	8.3.1.2	8.3.1.3	8.3.2.1	8.3.2.2	8.3.2.3	8.3.3.1	8.3.3.2	8.3.3.3	8.3.3.4	8.3.3.5	8.3.3.6
5.4.2	Voltage-active power (volt-watt) mode	R	NR	R	NR	R	NR	NR	R	NR	NR	NR	NR
6.2	Area EPS faults and open phase conditions	R	R	R	NR	R	NR	NR ^a	NR	NR	NR	NR	NR ^b
6.3	Area EPS reclosing coordination	R	R	R	NR	NR	NR	D	NR	NR	NR	NR	D
6.4.1	Mandatory voltage tripping requirements	R	R	R	NR	R	NR	NR	NR	NR ^b	NR	NR	NR
6.4.2.1	General requirements and exceptions	R	NR	R	NR	R	NR	NR	NR	D	NR	NR	NR
6.4.2.2	Voltage disturbances within continuous operation region	R	NR	R	NR	NR	NR	NR	NR	D	NR	NR	NR
6.4.2.3.2	Low-voltage ride-through capability	R	NR	R	NR	NR	NR	NR	NR	D	NR	NR	NR
6.4.2.3.3	Low-voltage ride-through performance	R	NR	R	NR	NR	NR	NR	NR	D	NR	NR	NR
6.4.2.4.2	High-voltage ride-through capability	R	NR	R	NR	NR	NR	NR	NR	D	NR	NR	NR
6.4.2.4.3	High-voltage ride-through performance	R	NR	R	NR	NR	NR	NR	NR	D	NR	NR	NR
6.4.2.4.5	Ride-through of consecutive voltage disturbances	R	NR	R	NR	NR	NR	NR	NR	D	NR	NR	NR
6.4.2.6.1	Dynamic voltage support capability	R	NR	R	R	NR	NR	NR	NR	D	NR	NR	NR
6.4.2.6.2	Dynamic voltage support performance	R	NR	R	R	NR	NR	NR	NR	D	NR	NR	NR
6.4.2.7.1	Restore output without dynamic voltage support	R	NR	R	R	NR	NR	NR	NR	D	NR	NR	NR
6.4.2.7.2	Restore output with dynamic voltage support	R	NR	R	R	NR	NR	NR	NR	D	NR	NR	NR
6.4.2.7.3	Transition between performance operating regions for Category III DER	R	NR	R	R	NR	NR	NR	NR	D	NR	NR	NR
6.5.1	Mandatory frequency tripping requirements	R	R	R	NR	R	NR	NR	NR	D	NR	NR	NR
6.5.2.7.1	Frequency-droop (frequency-power) capability	R	NR	R	R	R	NR	NR	NR	D	NR	NR	NR
6.5.2.7.2	Frequency-droop (frequency-power) operation	R	NR	R	R	R	NR	NR	NR	D	NR	NR	NR
6.6	Return to service after trip	R	NR	R	R	R	NR	D	NR	D	NR	NR	NR

Table continues

Subclause in IEEE Std 1547-2018		Subclause in IEEE Std 1547.1											
Subclause number	Title	DE1 – Confirm pertinent <i>type test</i> and <i>production test</i> requirements are met	DE2 – Confirm with protection and impact study	DE3 – System design review	IE1 – Verify installation matches <i>design evaluation</i>	IE2 – Verify system settings	IE3 – Verify state of system	CT1 – On-off test	CT2 – Reactive power capability and control verification	CT3 – Voltage and frequency tests	CT4 – Power quality tests	CT5 – Interoperability tests	CT6 – Islanding Test
		8.3.1.1	8.3.1.2	8.3.1.3	8.3.2.1	8.3.2.2	8.3.2.3	8.3.3.1	8.3.3.2	8.3.3.3	8.3.3.4	8.3.3.5	8.3.3.6
7.1	Limitation of dc injection	R	NR	R	R	NR	NR	NR	NR	NR	NR ^b	NR	NR
7.2.2	Rapid voltage changes (RVC)	NR	R	R	NR	NR	NR	NR	NR	NR	D	NR	NR
7.2.3	Flicker	NR	R	R	NR	NR	NR	NR	NR	NR	D	NR	NR
7.3	Limitation of current distortion	R	NR	R	R	NR	NR	NR	NR	NR	D	NR	NR
7.4	Limitation of overvoltage contribution	R	R	R	R	NR	NR	NR	NR	NR	D	NR	NR
8.1	Unintentional islanding	R	R	R	R	R	NR	NR	NR	NR	NR	NR	R
8.1.2	Conditional extended <i>clearing time</i>	NR	R	R	R	NR	NR	NR	NR	NR	NR	NR	R
8.1.3	Area EPS with automatic reclosing	NR	R	R	R	NR	NR	NR	NR	NR	NR	NR	R
8.2.2	Scheduled <i>intentional islands</i>	NR	R	R	R	NR	NR	NR	NR	NR	NR	NR	R
8.2.3	Unscheduled <i>intentional islands</i>	NR	R	R	R	NR	NR	NR	NR	NR	NR	NR	R
8.2.4	Conditions for unscheduled transition to <i>intentional island</i>	NR	R	R	R	NR	NR	NR	NR	NR	NR	NR	R
8.2.5	Transition of an <i>intentional island</i> from the <i>area EPS</i>	NR	R	R	R	NR	NR	NR	NR	NR	NR	NR	R
8.2.6	Reconnection of an <i>intentional island</i> to the <i>area EPS</i>	NR	R	R	R	NR	NR	NR	NR	NR	NR	NR	R
8.2.7	Adjustments to DER settings	NR	R	R	R	R	NR	NR	NR	NR	NR	NR	R
8.2.8	DER categories for microgrid <i>islands</i>	NR	R	R	R	NR	NR	NR	NR	NR	NR	NR	R
9.2	Distribution secondary grid networks	NR	R	R	R	R	R	D	NR	NR	NR	NR	D
9.3	Distribution secondary spot networks	NR	R	R	R	R	R	D	NR	NR	NR	NR	D
10.1	Interoperability requirements	R	NR	R	R	R	NR	NR	NR	NR	NR	D	NR
10.2	Monitoring, control, and information exchange requirements	R	NR	R	R	R	NR	NR	NR	NR	NR	D	NR
10.3	Nameplate information	R	NR	R	R	R	NR	NR	NR	NR	NR	D	NR

Table continues

Subclause in IEEE Std 1547-2018		Subclause in IEEE Std 1547.1											
Subclause number	Title	DE1 – Confirm pertinent <i>type test</i> and <i>production test</i> requirements are met	DE2 – Confirm with protection and impact study	DE3 – System design review	IE1 – Verify installation matches <i>design evaluation</i>	IE2 – Verify system settings	IE3 – Verify state of system	CT1 – On-off test	CT2 – Reactive power capability and control verification	CT3 – Voltage and frequency tests	CT4 – Power quality tests	CT5 – Interoperability tests	CT6 –Islanding Test
		8.3.1.1	8.3.1.2	8.3.1.3	8.3.2.1	8.3.2.2	8.3.2.3	8.3.3.1	8.3.3.2	8.3.3.3	8.3.3.4	8.3.3.5	8.3.3.6
10.4	Configuration information	R	NR	R	R	R	NR	NR	NR	NR	NR	D	NR
10.5	Monitoring information	R	NR	R	R	R	NR	NR	NR	NR	NR	D	NR
10.6.2	Constant power factor mode parameters	R	NR	R	R	R	NR	NR	NR	NR	NR	D	NR
10.6.3	Voltage-reactive power mode parameters	R	NR	R	R	R	NR	NR	NR	NR	NR	D	NR
10.6.4	Active power–reactive power mode parameters	R	NR	R	R	R	NR	NR	NR	NR	NR	D	NR
10.6.5	Constant reactive power mode parameters	R	NR	R	R	R	NR	NR	NR	NR	NR	D	NR
10.6.6	Voltage–active power mode parameters	R	NR	R	R	R	NR	NR	NR	NR	NR	D	NR
10.6.7	Voltage trip and momentary cessation parameters	R	NR	R	R	R	NR	NR	NR	NR	NR	D	NR
10.6.8	Frequency trip parameters	R	NR	R	R	R	NR	NR	NR	NR	NR	D	NR
10.6.9	Frequency droop parameters	R	NR	R	R	R	NR	NR	NR	NR	NR	D	NR
10.6.10	Enter service	R	NR	R	R	R	NR	NR	NR	NR	NR	D	NR
10.6.11	Cease-to-energize and trip	NR	NR	NR	NR	R	NR	NR	NR	NR	NR	D	NR
10.6.12	Limit maximum active power	R	NR	R	R	R	NR	NR	NR	NR	NR	D	NR
10.7	Communication protocol requirements	R	NR	R	R	NR	NR	NR	NR	NR	NR	D	NR
10.8	Communication performance requirements	R	NR	R	R	NR	NR	NR	NR	NR	NR	D	NR

Legend: R = required evaluation or test, D = test dependent on *design evaluation*, NR = no requirement, Shaded = no requirement in IEEE Std 1547-2018.

^aIEEE Std 1547-2018 identifies this test as not required (NR). It is recommended to consider *commissioning test* depending on *design evaluation*.

8.3.1 Detailed DER *design evaluation* for PoC composite

This subclause describes the detailed verification process for a system that has the RPA at the PoC and is partially compliant. This system type requires devices additional to the type tested *DER unit(s)* to be compliant with the requirements of the standard. Detailed *DER design evaluation* is done after equipment is selected and integration methods agreed to but before the installation of equipment on-site.

These requirements are in addition to the steps described in 8.1.4.1 that are required for all systems.

During this step, consideration shall be given to *area EPS operator* interconnection practices, AGIR, local code and existing power systems models of the distribution circuit. Additionally, the *commissioning tests* required for the *DER composite* are identified during this step.

NOTE—It is recommended that this step occur early in a project so that commissioning requirements can be included in the project plan.

8.3.1.1 *Design evaluation* DE1: Confirm pertinent *type test* and *production test* requirements are met

8.3.1.1.1 Purpose

The purpose of *design evaluation* DE1 is to confirm that the IEEE 1547 test requirements are met by the *DER composite*. Confirmation of these requirements shall be achieved by reviewing project documentation, certification, pertinent AGIR, and other pertinent documentation.

Where supplemental devices are used to meet requirements, the *DER unit type tests* do not fully determine the *DER composite's* capability to meet the IEEE 1547 requirements. This *design evaluation* determines for those requirements and other affected parameters whether the requirements are met. This may be accomplished by engineering judgment but may also require *installation evaluation* and/or *commissioning tests*.

8.3.1.1.2 Requirements

This evaluation shall be performed when the equipment performing the IEEE 1547 functions has been selected for the *DER system* design. The type-test results summary document for the *DER unit(s)* issued by the *testing agency* shall be used for the evaluation. The *DER unit* datasheet(s) shall be used to determine compliance to the system operation conditions.

8.3.1.1.3 Procedure

The procedure is as follows:

- a) Review the *design evaluation* documentation and consider the following for systems with RPA of PoC and partially compliant (Composite): Verify that the *DER composite* has been approved for the relevant requirements for this evaluation that are summarized in the “DE1” column in Table 73 with subclause number rows with an *R* (indicating required evaluation or test).
- b) Review DER documentation and compare to relevant requirements for this evaluation that are summarized in the “DE1” column in Table 73 (Rows 4.2 to 4.12). Determine if type testing or production testing has confirmed DER capability. Use this information to determine whether

8.3.3.1 [*Commissioning test* CT1 (On/Off) in Table 73] or 8.3.3.2 [CT2 (Synchronization) in Table 73] are required.

- c) Review DER documentation and compare to relevant requirements for this evaluation that are summarized in the “DE1” column in Table 73 (Rows 5.2 to 6.6 and Rows 8.1 to 9.3). Determine if type testing or production testing has confirmed DER capability. Use this information to determine whether 8.3.3.3 [*Commissioning test* CT3 (Voltage and Frequency)] or 8.3.3.2 [CT2 (Synchronization)] are required.
- d) Review DER documentation and compare to relevant requirements for this evaluation that are summarized in the “DE1” column in Table 73 (Rows 7.1 to 7.4). Determine if type testing or production testing has confirmed DER capability. Use this information to determine whether 8.3.3.4 [*Commissioning test* CT4 (Power Quality) in Table 73]) are required.
- e) Review DER documentation and compare to relevant requirements for this evaluation that are summarized in the “DE1” column in Table 73 (Rows 10.1 to 10.8). Determine if type testing or production testing has confirmed DER capability. Use this information to determine whether 8.3.3.5 [*Commissioning test* CT5 (Interoperability) in Table 73] are required.
- f) DER *design evaluation* DE1 report shall be in any format mutually agreeable between the *area EPS operator* and the DER owner or operator. The *design evaluation* DE1 report may include pre-certification of *DER units* or systems by the *area EPS operator*, regulatory bodies or other mutually agreeable third parties. Where field conditions make it impractical to test equipment in situ, the use of signal injections shall be allowed.

8.3.1.1.4 Criteria

The evaluation shall verify that pertinent requirements for the categories are met. Results of this evaluation shall be documented, highlighting acceptance or failure and any corrective actions needed. This evaluation may result in the need for further confirmation by *commissioning tests*. The items that require further confirmation by *commissioning tests* should be clearly identified along with determination of what needs to be tested to confirm that the DER meets the requirements.

Failure of the documentation to demonstrate the required capability may generate a requirement for 8.3.3.1 [*Commissioning tests* CT1 (On/Off) in Table 73], 8.3.3.2 [CT2 (Synchronization) in Table 73], and/or 8.3.3.3 [CT3 (Voltage and Frequency) in Table 73], as determined by the EPS operator.

8.3.1.2 *Design evaluation* DE2: Confirm with protection and impact study

8.3.1.2.1 Purpose

If a protection and/or impact study is required, the purpose of this evaluation is to confirm and coordinate DER protection and control settings with the results from these studies. This evaluation is also to confirm whether voltage deviations meet IEEE 1547 requirements.

8.3.1.2.2 Requirements

This evaluation shall be performed once the equipment fulfilling the IEEE 1547 requirements have been selected and the *DER composite* has been fully designed, including specification of all equipment, controls, protections, communications and interconnecting components. *DER composite* protection settings shall be coordinated once results from the protection and impact studies are available.

8.3.1.2.3 Procedure

The procedure is as follows:

- a) Review owner's project requirements (OPR), and project specifications, for information specifically related to DER's specific settings and configurations.
- b) The *DER operator* shall provide to the *area EPS operator* upon request:
 - 1) For inverter technologies, oscillographic representation of the voltage and current data for all phases measured during fault current characterization type testing. See 5.18.1 for reference. Sequence impedance characteristics of the test source used during fault current characterization *type tests* shall be provided.
 - 2) For synchronous and induction generators parameters specified in 5.18.2.1, 5.18.2.2, or 5.18.2.3 shall be provided.
- c) Confirm that the *DER composite* interconnects according to Integration with *area EPS* grounding requirement in 4.12 in IEEE Std 1547-2018.
- d) Confirm that restore output settings coordinate with *area EPS* reclosing as required by 6.3 in IEEE Std 1547-2018 and that DER ceases to energize and trip during *area EPS* short circuit faults upon open phase instances as required by 6.2.1 and 6.2.2 of IEEE Std 1547-2018, respectively. Confirm trip settings match those in the protection study.¹⁰⁹
- e) Confirm ride-through capability of all components of the composite DER, and the composite DER as a system, have voltage and frequency ride-through capability meeting minimum requirements of 6.4¹¹⁰ and 6.5 in IEEE Std 1547-2018. Determine if *commissioning tests* are required to confirm.
- f) Confirm voltage trip settings and frequency tripping settings match those in the protection study and meet requirements in 6.4.1¹¹¹ and 6.5.1 in IEEE Std 1547-2018. Confirm voltage trip settings match those in the protection study.¹¹²
- g) Confirm that the fault current contribution from the *DER composite* does not adversely affect the function and operation of the protection equipment in the surrounding circuits.
- h) If impact study has been performed, verify that solutions for each have been implemented.
 - 1) Rapid voltage changes (RVC) (7.2.2 in IEEE Std 1547-2018). Determine if *commissioning tests* are required to confirm.
 - 2) Flicker (7.2.3 in IEEE Std 1547-2018). Determine if *commissioning tests* are required to confirm.
 - 3) Limitation of overvoltage contribution (7.4 in IEEE Std 1547-2018).
- i) If the GFOV and LROV tests were performed on the *DER units*, the results obtained from that *type tests* can be used to evaluate the effect of the DER on the *area EPS* overvoltage limits as defined in 7.4.1 of IEEE Std 1547.¹¹³
- j) If the DER is connected to a secondary grid or spot network, confirm that the DER is implemented as required in Clause 9 of IEEE Std 1547-2018 and will not cause misoperation of any network protector(s) or exceed any network protector rating.

Review DER documentation and compare to IEEE 1547 requirements identified in Table 73 to determine if type testing or production testing has confirmed capability and whether adjustments to the DER protection system are necessary.

¹⁰⁹The recloser protection settings should be as agreed upon with the *area EPS operator*.

¹¹⁰For the case where the zero-sequence continuity is not maintained between the PoC and PCC, subclauses 6.2 and 6.4 of IEEE Std 1547-2018 need to be complied with at the PCC.

¹¹¹For the case where the zero-sequence continuity is not maintained between the PoC and PCC, subclauses 6.2 and 6.4 of IEEE Std 1547-2018 need to be complied with at the PCC.

¹¹²The voltage trip protection settings should be as agreed upon with the *area EPS operator*.

¹¹³The results of the tests may inform the system design of the need for supplemental grounding sources in certain applications.

8.3.1.2.4 Criteria

The evaluation shall confirm DER settings and connection configuration with a protection and impact study on the *area EPS* system. The *area EPS operator* may specify other voltage and *clearing time* trip settings within the range of allowable settings. Adjustments to the settings of the *area EPS* protection systems or changes to the DER interconnection parameters may be needed to maintain proper fault *detection time* and protective relaying coordination intervals acceptable to the *area EPS operator*.

Failure of the documentation to demonstrate effective coordination may generate a requirement for 8.3.3.3 [Commissioning test CT3 (Voltage and Frequency)], as determined by the EPS operator.

8.3.1.3 Design evaluation DE3: System design review

8.3.1.3.1 Purpose

The purpose of this evaluation is to confirm that the system design requirements are met by the *DER unit* for the requirements listed below.

8.3.1.3.2 Requirements

This evaluation shall be performed when the *DER system* design is mostly complete and major DER equipment has been sized and selected.

8.3.1.3.3 Procedure

The procedure is as follows:

- a) Confirm that the *DER system* designed provides the means to measure, or otherwise determine, voltage and other parameters as necessary, and delivers compliance with all IEEE 1547 requirements at the PoC or PCC.¹¹⁴
- b) Confirm the following operating modes and settings requirements from *area EPS operator*¹¹⁵ and review that the *DER composite* is capable of providing the required operating mode.
 - 1) Enter service criteria: Enter service voltage and frequency settings, minimum intentional delay and rate-of-change of the active power.
 - 2) Voltage and reactive/active power control.
 - 3) Mandatory voltage and frequency tripping setpoints.
 - 4) Voltage regulation and ride-through performance categories.
 - 5) Dynamic voltage support if DER specified with that capability.
 - 6) Frequency-droop control parameters.
 - 7) Inertial response, if required by *area EPS operator*.
 - 8) Islanding.^{116, 117}

¹¹⁴For the case where the zero-sequence continuity is not maintained between the PoC and PCC, subclauses 6.2 and 6.4 of IEEE Std 1547-2018 need to be complied with at the PCC.

¹¹⁵Such document may be referred to as a Utility Requirement Document by certain *area EPS operators*.

¹¹⁶Some unintentional islanding methods that were type tested may only provide partial compliance and when installed, may require specific implementation of field devices. In this scenario, conformance to the unintentional islanding requirement must be evaluated and may require a *commissioning test*.

- If intentional islanding is required, confirm if *DER composite* shall apply different control and protection settings.
 - If *area EPS operator* does not specify operating mode, *DER composite* shall be set to default mode.
- c) Confirm that the *DER composite* and equipment could not energize the *area EPS* when it is de-energized.
 - d) Review grounding scheme of *DER composite* and confirm that it is in coordination with the ground fault protection of the *area EPS*.
 - e) Review design of the *DER composite* in meeting the reactive power capability requirement. The *DER composite* may achieve the reactive power capability requirement with supplemental equipment such as, but not limited to, power factor correction capacitor bank. Consider the reactive power gains and losses within the *local EPS*, including cables, transformers, capacitors and reactors, as well as voltage levels within the *local EPS* over the range of active and reactive power outputs and PCC voltage, and the resulting limitations of reactive power created by such voltage levels.
 - f) Review how the following functions/requirements of the *DER composite* are implemented in order to achieve compliance at the PCC or PoC as is appropriate for the parameter.¹¹⁸
 - 1) Response to external input: Disabling of permit service setting, limiting active power, change in mode and parameters.
 - 2) Prioritization of operating modes.
 - 3) Enter service criteria: Enter service voltage and frequency settings, minimum intentional delay and rate-of-change of the active power.
 - 4) Review that the *DER composite* meets the requirements of 4.10 in IEEE Std 1547-2018 even though the subsystems making up the DER may perform these functions separately.¹¹⁹
 - 5) Voltage and reactive/active power control.
 - 6) Abnormal voltage: mandatory voltage tripping, voltage ride-through, dynamic voltage support, restore output after abnormal voltage condition.
 - 7) Abnormal frequency: mandatory frequency tripping, frequency ride-through, ROCOF ride-through, voltage phase angle changes ride-through, frequency-droop operation.
 - 8) Islanding.
 - Verify that the *DER composite* design provides compliance with unintentional islanding requirement.¹²⁰
 - For scheduled intentional islanding, review how request or command is sent by the DER or *area EPS operator*.
 - If DER is required to apply different control and protection settings, verify change in settings once in islanding mode.

If the function/requirement is performed by the system controller and this controller is type tested and approved for this function and the DER equipment are type tested and approved for this

¹¹⁷Additional DER integration issues may need to be evaluated for all *island* detection methods, including interactions of combinations of islanding detection methods on the same *area EPS*.

¹¹⁸For the case where the zero-sequence continuity is not maintained between the PoC and PCC, subclauses 6.2 and 6.4 of IEEE Std 1547-2018 need to be complied with at the PCC.

¹¹⁹For example, the DER equipment may perform the enter service voltage and frequency criteria function, however the system controller may perform the delay and active power rate-of-change functions, and various DER sources such as solar inverters, synchronous generators and/or energy storage may be apply different delay and active power generation setpoints.

¹²⁰Some unintentional islanding methods that were type tested may only provide partial compliance and when installed, may require specific implementation of field devices. In this scenario, the conformance to the unintentional islanding requirement must be evaluated and may require a *commissioning test*.

function, evaluate how the settings are aggregated to the DER equipment. Verify that the communication and input/output between the system controller and DER as well as settings on this equipment are coordinated. This review with the certification of this equipment would suffice.

If the function/requirement is performed by the system controller and this controller is not type tested or approved for this function however the DER equipment is type tested and approved for this function, further evaluation is required. This may include, but not limited to, a review of the system controls, state sequencing diagram and/or bench test.

If the function/requirement is performed by DER equipment that is not type tested or approved for this function, a detailed evaluation is required. This may include performing the *type test* on the *DER composite* system as outlined in this standard.

- g) When required by the *area EPS operator* and by performing a system impact study, evaluate the *DER composite* for impact on power quality of *area EPS* that it is connected to. This *design evaluation* may indicate risk of exceeding the required limits. In this case, *commissioning test* may be needed.

- 1) Evaluate equipment and/or operation that may cause RVC such as energization of transformers, switching of capacitor banks for reactive power support, or abrupt change in power output.¹²¹

To measure voltage for RVC at the PCC, use appropriate measurement devices that are capable of capturing rms voltage on one cycle basis.

The RVC limits shall not apply to infrequent events such as switching, unplanned tripping, or transformer energization related to commissioning, fault restoration or maintenance, however operation of these events may be performed to understand the impact on the *area EPS*.

- 2) Evaluate flicker results from DER equipment *type test* and any loads in the *DER composite* that may cause flicker. Using the DER equipment *type test* results, summation law in IEC/TR 61000-3-7 may be used to evaluate the potential flicker cause by the *DER composite*. Alternatively, IEC 61400-21 defines flicker coefficient for certain types of power generation devices and provides methods to predict for potential flicker based on the grid characteristics at the PCC.
- 3) Identify equipment that may potentially be harmonic sources and/or loads and evaluate current distortion results from DER equipment *type test*. Individual harmonic source contributions may be combined using the harmonic summation laws in IEC 61000-3-6. Consider the impact of shunt and series harmonic impedances within the *local EPS*, including capacitors, transformers, and cables, which may attenuate harmonics or may form resonances with the *area EPS* harmonic impedance to amplify harmonic currents.

DER that meet current distortion limits when connected to an undistorted external system, such as during type testing, may exceed current distortion limits when connected to a field environment having voltage distortion. IEEE 1547 limitations on harmonic current distortion specifically exclude harmonic currents due to *area EPS* voltage distortion not caused by the DER. Such ambient distortion is invariably present, thus making difficult or impossible the task of evaluating distortion compliance in the field.

Design evaluation may indicate risk of exceeding the current distortion requirement and in this case, the current distortion of the *DER composite* shall be measured during commissioning of DER. If the DER current distortion exceeds the limits allowed in IEEE Std 1547, the DER owner shall determine the appropriate resolution.

¹²¹Sequencing of equipment operation such as energization of transformers, controlled ramp-up of output power and smaller step changes of capacitor banks may aid in reducing the magnitude of RVC.

- h) Verify that the *DER composite* with system controller can communicate with *area EPS* with one of the protocols listed in 10.7 of IEEE Std 1547-2018 and capable to meet the communication performance requirements in 10.8 of IEEE Std 1547-2018.
- i) If connected to a grid or spot secondary distribution network, confirm that the control and protection of the *DER system* properly coordinates with the settings and status of network protectors in the *area EPS*.

8.3.1.3.4 Criteria

The *DER composite* shall be considered in compliance if it has been evaluated and confirmed meeting the requirements of IEEE Std 1547. Identify any gap that shall be evaluated during DER installation and commissioning.

8.3.2 Detailed DER *installation evaluation* for PoC composite

The Detailed DER *installation evaluation* is performed on-site after equipment is delivered and put in place. This is an evaluation prior to or at the time of commissioning to verify that the *DER composite* as delivered and installed meets the interconnection and interoperability requirements of IEEE Std 1547, as well as the local regulatory and EPS operator requirements. The primary inputs to this are the *design evaluation* documentation and a physical inspection of the system, as installed. In addition, for partially compliant systems certification of additional devices within the system may be required.

Results of this evaluation shall be documented, highlighting acceptance or failure and any corrective actions needed. This evaluation may result in the need for further actions prior to *commissioning tests*.

8.3.2.1 *Installation evaluation* IE1: Verify installation matches *design evaluation*

8.3.2.1.1 Purpose

The purpose of this evaluation is to verify that the equipment installed is that evaluated under the DER *design evaluation* and has been installed correctly, with the correct equipment. The evaluation shall determine whether the *DER unit* complies with the pertinent IEEE 1547 requirements identified in this subclause by verifying that the specified equipment with correct parameters and configurations has been installed.

In addition, any corrective actions identified in the DER *design evaluation* shall be verified as complete.

The *DER composite* may comprise of system level controller that controls multiple DER equipment, receives measurement from devices that measure various parameters such voltage, current, active and reactive powers. These devices may be designed together to fulfill the requirements of IEEE Std 1547. This evaluation shall confirm continuity of the end-to-end physical wiring from the DER *plant controller*, if any, to the measurement devices and DER equipment providing the IEEE 1547 functions.

The procedures included in this subclause also verifies correct application of external inputs to the *DER composite* such as the permit service setting and active power limit, which may be received by the DER via communication interface or hardwire digital or analog signals.

8.3.2.1.2 Requirements

This *installation evaluation* shall be performed prior to commissioning. Alternatively, this *installation evaluation* shall be on an on-going basis through-out completion of project installation.

Some of the procedures may require availability of the DER control power to access the DER plant and/or unit controller board and interface.

8.3.2.1.3 Procedure

The procedure is as follows:

- a) Review the results of the DER *design evaluation* and project documentation for information specifically related to *DER unit's* project-specific settings and configurations.
- b) Confirm that the actual installation is complete.
- c) Confirm that equipment on site is that used in the basic DER *design evaluation* and matches project documentation.
This is done by confirming that nameplate data of installed equipment matches that identified in the *design evaluation* and project documentation.
Nameplate data includes model number, serial number, configuration information, and other parameters.
- d) If required by the *area EPS operator*, verify isolation device between the *DER composite* and *area EPS* and implementation for accessible, lockable and visible break device and clearly marked accordingly.
- e) Perform end-to-end verification of the wiring from the measurement devices to the associated controller(s) and from the associated controller to the DER equipment and interconnection devices that serve the function of meeting the IEEE 1547 requirements. Verification is achieved by referencing the DER design documentation and performing specific procedure from the DER designer and equipment manufacturer, which may include the following:
 - 1) Energizing measurement bus with appropriate voltage and current, then confirming reading at the controller and within the acceptable accuracy range.
- f) Perform end-to-end verification of the external input wiring to the *DER composite*. Verification is achieved by referencing the DER design documentation and performing specific procedure from the DER designer, which may include the following:
 - 1) Energizing or providing appropriate commands or signals at the external input connection point, then confirming reading at the DER controller and aggregation of commands or signals to the DER equipment.
- g) Confirm availability of a local DER communication interface and that the following list of information exchange is available from the DER: nameplate, configuration, monitoring, and management information.

8.3.2.1.4 Criteria

Confirmation of these requirements shall be achieved by reviewing the results of the *design evaluation* and inspecting the *DER unit* as installed to verify that the installation and configuration matches that of the project documentation and the design review.

Failure of the documentation and inspection to demonstrate that the installation matches the *design evaluation* may result in corrective actions needing completion before commissioning and may also generate a requirement for 8.3.3.1 [*Commissioning tests* CT1 (On/Off) in Table 73] and/or 8.3.3.2 [CT2 (Synchronization) in Table 73], as determined by the EPS operator.

8.3.2.2 Installation evaluation IE2: Verify system settings

8.3.2.2.1 Purpose

The purpose of this evaluation is to verify that equipment has required settings as agreed upon by the *DER operator* and the *area EPS operator*.

In addition, this evaluation is to confirm the availability of information of the *DER composite* via the local DER communication interface and that the IEEE 1547 pertinent system settings are applied per the requirements listed below and project documentation. Confirmation of this shall be achieved by reviewing the actual settings in the installed equipment and verifying them against the settings provided in project documentation.

The procedures below require availability of the DER control power to access the DER plant and/or unit controller board and interface.

8.3.2.2.2 Requirements

This *installation evaluation* shall be performed when the DER installation is nearing completion and the control system of the pertinent DER equipment can be energized.

8.3.2.2.3 Procedure

The procedure is as follows:

- a) Review the results of the *design evaluation* and project documentation for information specifically related to *DER unit's* project-specific settings.
- b) Verify correct installation settings by identifying settings in the *DER unit* related to the interconnection as defined in DER *design evaluation* DE2 [8.3.1.2.3 c) and d)]. Compare settings with the manufacturer's production report.
- c) Verify that the parameters listed in 10.3 through 10.6 of IEEE Std 1547-2018 are available and read-capable or write-capable via the local DER communication interface at the PoC according to requirements stated.
- d) The following settings shall be confirmed with the *area EPS operator* and shall be adjusted in the DER devices or the DER *plant controller* accordingly. If not specified by *area EPS operator* or AGIR, default values as specified in IEEE Std 1547 shall be used.
 - 1) Enter service parameters:
 - i) Enter service adjustable time delay
 - ii) Enter service adjustable time period
 - iii) Enter service maximum active power increase of any single step
 - 2) Voltage and reactive power control mode:
 - i) Either constant power factor mode, voltage-reactive power mode, active power-reactive power mode or constant reactive power mode. If not specified by *area EPS operator*, default mode is constant power factor mode.
 - ii) If constant power factor mode is selected, apply the power factor setting.
 - iii) If voltage-reactive power mode is selected, apply the voltage-reactive power parameters per Table 8 of IEEE Std 1547-2018.
 - iv) If active power-reactive power mode, apply the active power-reactive power parameters per Table 9 of IEEE Std 1547-2018.

- v) If constant reactive power mode is selected, apply the reactive power setting.
- 3) Voltage and active power control mode:
 - i) Enable voltage-active power mode if specified by *area EPS operator*. If not specified, default mode is disabled.
 - ii) If voltage-active power mode is selected, apply the voltage-active power parameters per Table 10 of IEEE Std 1547-2018.
 - 4) Response to *area EPS* abnormal voltages:
 - i) Ride-through performance category.
 - ii) Voltage trip and *clearing time* settings for Category I, II, or III, accordingly.
 - 5) Response to *area EPS* abnormal frequencies:
 - i) Ride-through performance category.
 - ii) Frequency trip and *clearing time* settings for Category I, II, or III, accordingly.
 - iii) Frequency-droop parameters per Table 24 of IEEE Std 1547-2018.
- e) Verify that these parameters are adjustable locally and/or remotely as specified by the *area EPS operator*. If remotely, verify that the remote controller or access can provide the settings and that the DER equipment can receive the settings. This verifies the continuity of the end-to-end communication wiring.
 - f) Verify the DER equipment software and firmware revision and confirm with the DER equipment manufacturer of the revisions that meets the IEEE 1547 requirements.
 - g) If any upgrade is required, verify that correct parameters and settings are applied to the upgraded software and firmware revision. It is advisable that the *DER operator* is aware of and understand the changes of the software or firmware revisions to evaluate the impact of the changes to the DER operation. This may be done by requesting the design change documentation, integration with DER, evaluating impact, and performing bench test of the DER plant controls and operation, or by other means.
 - h) Once completed, settings adjustments shall be recorded and provided to *area EPS operator* for confirmation and reference.
 - i) If interconnected to a secondary grid or spot network, coordinate *DER composite* settings with network protector controls and protector status as required by IEEE Std 1547 and confirm with *area EPS operator*.

8.3.2.2.4 Criteria

Application of settings as specified by *area EPS operator*. If not specified, apply default settings. Once completed, settings adjustments shall be recorded and provided to *area EPS operator* for confirmation and reference.

Software and firmware revisions are as expected. If upgrade is required, performance of the *DER composite* still meets the IEEE 1547 requirements.

8.3.2.3 Installation evaluation IE3: Verify state of system

8.3.2.3.1 Purpose

The purpose of this evaluation is to verify state of *DER composite* when the system is energized with control power and prior to system start-up.

8.3.2.3.2 Requirements

This *installation evaluation* shall be performed when the DER installation is completed and the control system of the pertinent DER equipment can be energized.

8.3.2.3.3 Procedure

The procedure is as follows:

- a) Visually inspect and verify operability of the isolation device, as specified in the governing interconnection agreement.
- b) With the *DER composite* deenergized and control power to DER available, command the *DER composite* to start-up. The *DER composite* can be in the deenergized state if the main system switchgear is in open position and DER is not connected to the *area EPS*. If the *DER composite* consists of one make and model of DER equipment, one test on one unit of DER equipment can represent behavior of all DER equipment in the system, with the condition that DER equipment parameters and setting are similar in all DER equipment. If the *DER composite* consists of multiple makes and models of DER equipment, or the DER equipment do not all contain similar parameters and settings, this test shall be performed on the each type DER equipment.
- c) If interconnected to a secondary distribution spot network, verify that the *area EPS* network bus is energized by more than 50% of the installed network protector prior to permitting the connection of the *DER composite* to the *area EPS*.

8.3.2.3.4 Criteria

DER composite shall not proceed to start and energize the *area EPS* when *area EPS* is not energized. Connection of the *DER composite* to *area EPS* is only permitted if *area EPS* network is already energized by more than 50% of the installed network protector.

8.3.3 Detailed DER commissioning tests for PoC composite

The *DER composite commissioning tests* are conducted after installation of the system has been completed, all de-energized checks have been passed and system has been approved for energization. In addition to the tests outlined in this subclause, any tests determined from the design and *installation evaluations* shall be performed as part of the *commissioning test* to verify compliance.

8.3.3.1 Commissioning Test CT1: On-off test

8.3.3.1.1 Purpose

The purpose of this test is to evaluate the impact of DER energization and operation on the *area EPS*. The *DER composite* shall be brought online, operated up to maximum available capacity,¹²² and put through planned and unplanned shutdown sequences.

¹²²For installations that are dependent on input source availability such as solar and wind installations, *DER system* needs to be operated up to the available capacity at the time of test or as agreed with the *area EPS operator*.

8.3.3.1.2 Requirements

This test shall be performed when the *DER composite* has passed deenergized and pre-energization checkouts and has been approved for energization and operation at the specified operating modes. The *area EPS operator* may require representation during initial energization and during the testing of the *DER system*.

8.3.3.1.3 Procedure

The descriptions outlined in this subclause are recommended actions. Tests shall be performed as required and agreed with the *area EPS operator*. Detailed test procedures shall be developed in coordination with the DER designer and equipment manufacturer.

- a) When the *area EPS* is de-energized, observe that the *DER composite* does not energize the *area EPS*, with the exceptions of conditions as outlined in 8.2 of IEEE Std 1547-2018.
- b) With the *DER composite* in the OFF state, bring the DER online. The *DER composite* shall be set to the specified operating mode, active, reactive power or power factor setpoints. Confirm that the DER starts to come online (delivering power into the *area EPS*) or makes connection to the *area EPS* when the DER voltage and frequency are within range specified in Table 4 or Table 5 of IEEE Std 1547-2018 and permit service is enabled. During the start-up of the *DER composite*, observe the *area EPS* voltage response (transient and steady-state), any intentional delay and power ramping until the *DER composite* reaches a steady-state operation. Simulate a disconnect and reconnect condition and observe the return to service of the DER. This may be achieved by manually triggering a disconnect of the DER from the *area EPS* using a device other than the interconnection device that provides the cease-to-energize function or creating a temporary abnormal condition by adjusting the window of voltage operation to cause a disconnect, or by other means. Once the DER is disconnected, this parameter is reversed to allow for reconnect or return to service.
- c) If the *DER composite* is unable to reasonably show in the *design evaluation* phase that it limits the active and reactive power export to the *area EPS* per the requirements in 4.5 of IEEE Std 1547-2018 during the cease to energize state, the DER shall be tested. Active and reactive power export shall be measured. The measurement shall be taken at the *point of common coupling* to the *area EPS*. The *DER composite* shall be operated at full power and nominal voltage condition and a cease to energize condition shall be initiated.
- d) With the *DER composite* operating and generating power, it shall be verified for response to external inputs including permit service, active power limit and operating modes. These inputs shall be provided at the external input connection point and DER response shall meet the performance and response time requirements of 4.6 in IEEE Std 1547-2018.
- e) Disconnect all ungrounded phases from the *area EPS* simultaneously using a device other than the interconnection component that provides the cease-to-energize function.
 - 1) Verify that the *DER unit* ceases to energize the output terminals connected to the *area EPS* compliant to 6.2.2 of IEEE Std 1547-2018.
 - 2) After a convenient period, reclose the selected disconnect.
- f) For multi-phase DER, disconnect one ungrounded phase from the *area EPS* using a device other than the interconnection component that provides the cease-to-energize function. This open phase shall be performed at the PoC with no significant load, transformers, or reactive compensation devices connected between the open point and the PoC.
 - 1) Verify that the *DER unit* ceases to energize the output terminals connected to the *area EPS* compliant to 6.2.2 of IEEE Std 1547-2018.
 - 2) After a convenient period, reclose the selected disconnect.
- g) Perform any other tests determined to be necessary by the DER and *area EPS operator* as the outcome from the *design evaluation*.

8.3.3.1.4 Criteria

Observe the *area EPS* response and *DER composite* stability. Review observation with *area EPS operator* and perform any adjustment to operating parameters/setpoints in coordination with *area EPS operator* as necessary.

8.3.3.2 Commissioning Test CT2: Reactive power capability and control verification

8.3.3.2.1 Purpose

The purpose of this test is to verify the reactive power capability and control of the *DER composite*. The *DER composite* may consist of multiple active and reactive power sources. The operation of the DER and impact to the *area EPS* shall be observed.

8.3.3.2.2 Requirements

The *DER composite* may consist of multiple reactive and active power sources. This test shall be performed when each of the sources has passed deenergized and pre-energization checkouts and has been approved for energization and operation.

8.3.3.2.3 Procedure

The descriptions outlined in this subclause are recommended actions. Tests shall be performed as required and agreed with the *area EPS operator*. Detailed test procedures shall be developed in coordination with the *DER system* designer and equipment manufacturer.

- a) Perform tests at both ends of the reactive power capability limits and two additional and distinctly different values in between the two limits, exercising all sources of reactive power designed in the *DER composite*.¹²³ The selective var setpoints to be verified shall be agreed with the *area EPS operator*. Observe the *area EPS* response (transient and steady state) to the reactive power sweep, verifying smooth and continuous variations in the net reactive power.
- b) Operate the *DER composite* in the reactive power mode selected and approved by the *area EPS operator*.
- c) If the constant power factor or constant reactive power modes are selected, verify that the mode selection, power factor and reactive power setpoints can be adjusted by the *area EPS operator*. Select several setpoints to be tested and agreed by the *area EPS operator*.
- d) If the voltage-reactive, active-reactive, or voltage-active power modes are selected, the operation of the control curve may need to be demonstrated as required by the *area EPS operator*. *Reference point of applicability* for this demonstration shall be at the PoC and shall include exercising of all reactive and active power sources. Selection of operating points of the curves shall be agreed by the *area EPS operator*, however recommendation includes the knee points of the curve and one point in each curve region.

¹²³In some cases, in order to supply the reactive power required, a *DER composite* may contain a capacitor bank to extend the range of variable reactive power sources. The control of the capacitor bank may introduce a step change in reactive power. The *DER composite* may also contain a power converter type interface which could provide a smooth ramp of reactive power. The combination of DER and supplemental devices and the *DER composite* as a whole may supply smooth and continuous variations in the net reactive power.

8.3.3.2.4 Criteria

Observe the *area EPS* response and DER stability. Review observation with *area EPS operator* and perform any adjustment to operating parameters/setpoints in coordination with *area EPS operator* as necessary.

8.3.3.3 Commissioning Test CT3: Voltage and frequency tests

8.3.3.3.1 Purpose

The purpose of this test is to verify the *DER composite* under test shall cease to energize when there is undervoltage, overvoltage, underfrequency, and overfrequency. The test results must meet the specified magnitude and *clearing time* as specified in IEEE Std 1547.

In addition, the voltage and frequency tests must demonstrate DER is actively limiting the DER maximum active power as a function of the voltage following a voltage-active power piecewise linear characteristic.

8.3.3.3.2 Requirements

This test shall be performed when the *DER composite* has passed deenergized and pre-energization checks and has been approved for energization and operation at the specified operating modes. *DER composite* has achieved stable operation at the specified conditions. The *area EPS operator* may require representation during initial energization and during the testing of the DER.

8.3.3.3.3 Procedure

The need for *commissioning tests* for PoC¹²⁴ systems is as displayed in Table 73. The need for any *commissioning test* for PoC systems is determined in the *design evaluation*. Tests shall be performed as required by the *area EPS operator* with details determined by mutual agreement between the *DER operator* and *EPS operator*. The DER responses to abnormal *area EPS* voltage and frequency conditions are typically performed by the DER devices which are type tested and approved for these functions due to complication of performing abnormal voltage and frequency tests in the field. *Design evaluation* is to have been performed prior to commissioning for the purpose of evaluating conformance of the *DER composite* to the *area EPS* abnormal voltage and frequency requirements and settings coordination. *Signal injection test methods* may be considered if the *DER composite* or devices have provisions for this method.

8.3.3.3.4 Criteria

Voltage and frequency tests shall meet the requirements in IEEE Std 1547. The characteristic shall be configured in accordance with the default parameter values specified in Table 10 of IEEE Std 1547-2018 for the given DER normal operating performance category.

The tests must also demonstrate that the DER meets the *clearing times* indicated for abnormal operating performance in IEEE Std 1547-2018 (see Table 11 for Category I, Table 12 for Category II, or Table 13 for Category III). Unless specified otherwise by the *area EPS operator*, default settings shall be used.

¹²⁴For the case where the zero-sequence continuity is not maintained between the PoC and PCC, subclauses 6.2 and 6.4 of IEEE Std 1547-2018 need to be complied with at the PCC.

8.3.3.4 Commissioning Test CT4: Power quality tests

8.3.3.4.1 Purpose

The purpose of this test is to verify that the impacts of the *DER composite* operation to the *area EPS* power quality are within the specified limits. Any of the power quality tests in the field shall be conducted if any field operational and performance issues arise, determined required from the *design evaluation* and if required by the *area EPS operator*.

Test cases and procedures shall be agreed with *area EPS operator* and may include evaluation at various conditions. Tests shall be performed including DER startup, disconnect and shutdown, full operating range of the *DER composite* as well as external conditions such as cloud coverage for solar plants and operation of other nearby facilities. The performance of the *DER composite* for power quality may be continuously observed by the *area EPS operator*.

8.3.3.4.2 Requirements

This test shall be performed when the *DER composite* has passed deenergized and pre-energization checkouts and has been approved for energization and operation at the specified operating modes. The *area EPS operator* may require representation during initial energization and during the testing of the *DER system*.

The measurement equipment used for power quality tests shall be compliant with IEC 61000-4-30 Class A.

8.3.3.4.3 Procedure

The description outlined in this subclause are recommended actions. Tests shall be performed as power quality issues arise or as required by and agreed with the *area EPS operator*. Detail test procedures shall be developed in coordination with the DER designer and equipment manufacturer.

- a) Connect the power quality measurement equipment at the PCC connection between the *DER composite* and the *area EPS*. The measurement equipment shall be capable of measuring ac, dc, rms, instantaneous and harmonic content of the voltages and currents, as well as frequency. A flicker meter may be used to measure any flicker contribution.
- b) Once the setup of measurement devices is complete, perform measurement of the *DER composite* operated under the following conditions:
 - 1) During start-up of the *DER composite*, energize (close in) the step-up transformers. Observe impact on the energization in-rush current to the *area EPS*.¹²⁵
 - 2) Turn-on *DER composite* and sweep the active and reactive power from 0 to full power, exercising (switch in and out) any sources of active and reactive power (such as capacitor banks). Observe impact to the *area EPS*.
 - 3) Perform a disconnect event that causes a step change in power delivery (not a soft shutdown, i.e., ramp down of power). Observe impact to the *area EPS*.¹²⁶
 - 4) Observe power quality of *area EPS* over a duration of time to capture nominal operating condition of the *DER composite*. The conditions would include, but not limited to, cloud coverage for solar DER, operation of other generation and load sources connected to the *area EPS*.

¹²⁵RVC limits in IEEE Std 1547 do not apply for infrequent transformer energizations, or energizations related to maintenance, outage restoration, or commissioning.

¹²⁶RVC limits in IEEE Std 1547 only apply to frequent and abrupt voltage variations that take place over a timespan of one second.

8.3.3.4.4 Criteria

Impacts of the DER operation to the *area EPS* power quality shall be within the specified limit. Review observation with *area EPS operator* and apply any mitigation action as necessary.

8.3.3.5 Commissioning Test CT5: Interoperability tests

8.3.3.5.1 Purpose

The purpose of *Commissioning test CT5* is to verify functionality of interoperability functions of the *DER composite* with the EPS operator.

8.3.3.5.2 Requirements

This test shall be performed when the DER installation is nearing completion, the control system of the pertinent DER equipment can be energized, and the *area EPS operator* has deployed the means to communicate with the *DER composite*.

8.3.3.5.3 Procedure

The procedure is as follows:

- a) Verify the DER equipment software and firmware revision and confirm with the DER equipment manufacturer of the revisions that meet the IEEE 1547 requirements.
- b) If any upgrade is required, verify that correct parameters and settings are applied to the upgraded software and firmware revision.
- c) It is advisable that the *DER operator* is aware and understands the changes of the software or firmware revisions to evaluate the impact of the changes to the DER operation. This may be done by requesting the design change documentation, integration with DER, evaluating impact and performing bench test of the DER plant controls and operation, or by other means.
- d) Verify that the EPS operator can access and read and/or write as appropriate the parameters confirmed in 8.3.2.2 (*Installation evaluation IE2* in [Table 73](#)).

8.3.3.5.4 Criteria

The *DER composite* shall be considered in compliance if software and firmware revisions meet the function and performance requirements for the *area EPS operator* in IEEE Std 1547 and if the *area EPS operator* is able to access and or read and/or write as appropriate the parameters as specified in Clause 10 of IEEE Std 1547-2018.

8.3.3.6 Commissioning Test CT6: Islanding test

8.3.3.6.1 Purpose

The purpose of this test is to verify the correct response of a *DER composite* to the islanding requirements in IEEE Std 1547.

8.3.3.6.2 Requirements

This test shall be performed when the *DER composite* has passed deenergized and pre-energization checkouts and has been approved for energization and operation at the specified operating modes. The *area EPS operator* may require representation during the islanding test.

8.3.3.6.3 Procedure

Determine the capability of a *DER composite* and the agreed-upon islanding operating mode.

Based on this determination, either the unintentional islanding test procedure (8.3.3.6.3.1) or the intentional islanding test procedure (8.3.3.6.3.2) shall be followed. Any other requirement and specific alteration to the procedure shall be agreed upon between the *area EPS operator* and *DER operator*.

8.3.3.6.3.1 Unintentional islanding test procedure

If a reverse-power or minimum power function is used as the method to detect unintentional islanding, it shall be tested by *signal injection test methods*, by adjusting the DER output and local loads, or by other suitable methods to verify that the function is met and that the DER ceases to energize the *area EPS*. Reverse-power or minimum power *type test* procedure may be used as a reference to design the test applicable for the field installed DER.

For a *DER composite* that uses direct transfer trip (DTT) method to comply with the unintentional islanding requirement, a DTT *signal injection test method*, or other method as specified by the *area EPS*, shall be used to verify compliance.

For the following means of *island* detection compliance, the procedure steps a) through f) shall apply:

- A DER that uses powerline conducted permissive signal method to comply with the unintentional islanding requirement. The disconnection point shall occur between the signal generation point and the signal detection point.¹²⁷
- A DER verified to have autonomous capabilities to detect unintentional islands in accordance with the tests specified in 5.10.2.
 - a) Verify that the DER is energized and connected to the *area EPS*.
 - b) Verify that the DER is configured with its applicable operating settings and is operating normally.
 - c) Create an islanding condition by disconnecting the DER from the *area EPS* using a device other than the interconnection device of the DER that provides the cease-to-energize function.
 - d) Measure the time from the creation of the *island* until the DER ceases to energize the *area EPS*.
 - e) The time should meet either the 2 s requirement or the conditional extended *clearing time* agreed between the *area EPS operator* and the *DER operator*.
 - f) Remove the islanding condition and observe the DER reclosing to the *area EPS* meets the performance requirements in 6.3 of IEEE Std 1547-2018.

¹²⁷The commissioning of a DER that uses powerline conducted permissive signal method is more involved than the scope of this standard.

8.3.3.6.3.2 Intentional islanding test procedure

For *DER composite* intended to be operated as an *intentional island*, determine the capability of a *DER composite* to operate in an *intentional island* mode. There are two means by which an *intentional island* system can transition to an islanded condition—scheduled and unscheduled.

- a) Verify that the DER is energized and connected to the *area EPS*.
- b) Verify that the DER is configured with its applicable operating settings and is operating normally.
- c) Create an *island* condition.
 - 1) For a scheduled *intentional island*: Create the *island* by providing the islanding command (manual action or other dispatch means that trigger the transition).
 - 2) For an unscheduled *intentional island*: Create the *island* by creating an abnormal condition on the *area EPS*.
- d) Verify the DER transition from operation in parallel and synchronized with the *area EPS* to islanded mode. Observe the impact and stability of DER and *area EPS* operation during and after the transition.
- e) If applicable, certain DER may have to adjust several control and protection settings when operating in the intentional *area EPS island*. In this case, verify that these alternate settings and ranges were adjusted in the *intentional island* operating mode.
- f) Remove the islanding condition and observe that the DER reconnection to the *area EPS* occurs based on 8.2.6 of IEEE Std 1547-2018.

8.3.3.6.4 Criteria

The *DER composite* shall be considered in compliance if it passes all the applicable islanding tests, meets the time requirements within the specified limit, and meets the performance of the islanding transition based on Clause 8 of IEEE Std 1547-2018. Review observation with *area EPS operator* and apply any mitigation action as necessary.

8.4 PCC-System: Basic DER evaluations and commissioning tests for DER units and DER systems with RPA at PCC¹²⁸

This subclause describes the basic verification process for a *DER unit* or *DER system* that has the RPA at the PCC. Where the effective impedance between the PCC and PoC is greater than 0.5% on the DER base, the verifications in this clause shall be applied. Where the PoC and PCC are the same location or are separated by an effective impedance less than 0.5%, the verifications in 8.2 and 8.3 may be applied.

DER units in this category must be capable of achieving full IEEE 1547 compliance at the PCC without the use of any supplemental devices and must have been installed in accordance with the DER manufacturer's instructions.

A *DER system* consists of *DER units* that are partially compliant at the RPA and supplemental devices, which as a system, has been type tested to meet the IEEE 1547 requirements and has been installed in accordance with the DER manufacturer's instructions.

The list of *design evaluations*, *installation evaluations* and *commissioning tests* outlined in this subclause are provided as a recommendation. Specific evaluations and tests shall be performed in accordance with *area EPS operator* interconnection requirements.

¹²⁸See definitions of *DER unit* and *DER system* in 3.1. Both of these are type tested and fully compliant at the RPA.

IS 18969 : 2024

In addition to the procedures described in 8.1.4.1 that are required for all system evaluation, the content in this subclause shall be considered.

Table 74 summarizes the relevant IEEE 1547 requirements that should be verified, and the column with an *R* or a *D* indicates that the verification step is required.

Table 74— Verification summary for PCC system

Subclause in IEEE Std 1547-2018		Subclause in IEEE Std 1547.1									
Subclause number	Title	DE1 - Confirm pertinent type test and operating conditions	DE2 - Confirm with protection and impact study	DE3 - DER unit/system information and fault current review	DE4 - System design review	IE1 - Verify installation matches design evaluation	IE2 - Verify information exchange and input applicable settings	IE3 - Verify state of system	CT1 - On-off test	CT2 - Voltage and frequency tests	CT3 - Power quality tests
		8.4.1.1	8.4.1.2	8.4.1.3	8.4.1.4	8.4.2.1	8.4.2.2	8.4.2.3	8.4.3.1	8.4.3.2	8.4.3.3
4.2	Reference points of applicability	R	NR	NR	R	R	NR	NR	NR	NR	NR
4.3	Applicable voltages	R	NR	NR	R	R	NR	NR	NR	NR	NR
4.4	Measurement accuracy	R	NR	NR	NR	R	NR	NR	NR	NR	NR
4.5	Cease-to-energize performance requirement	R	NR	NR	NR	NR	R	NR	D	D	NR
4.6.1	Capability to disable permit service	R	NR	NR	R	R	R	NR	D	NR	NR
4.6.2	Capability to limit active power	R	NR	NR	R	R	R	NR	D	NR	NR
4.6.3	Execution of mode or parameter changes	R	NR	NR	NR	R	NR	NR	D	NR	NR
4.7	Prioritization of DER responses and execution of mode or parameter changes	R	NR	NR	NR	R	NR	NR	D	NR	NR
4.8	Isolation device	NR	NR	NR	NR	R	NR	NR	NR	NR	NR
4.9	Inadvertent energization of the area EPS	NR ^a	NR	NR	NR	NR	NR	R	D	NR	NR
4.10.3	Performance during entering service	R	NR	NR	R	NR	R	NR	D	NR	NR
4.10.4	Synchronization	R	NR	NR	NR	R	NR	R	D	NR	NR
4.12	Integration with area EPS grounding	NR	R	NR	R	R	NR	NR	NR	NR	NR
5.2	Reactive power capability of the DER	R	NR	NR	NR	R	R	NR	D	NR	NR
5.3	Voltage and reactive power control	NR	NR	NR	NR	NR	R	NR	NR	NR	NR
5.3.2	Constant power factor mode	NR	NR	NR	NR	NR	R	NR	NR	NR	NR
5.3.3	Voltage-reactive power (volt-var) mode	NR	NR	NR	NR	NR	R	NR	NR	NR	NR
5.3.4	Active power-reactive power (watt-var or P-Q) mode	NR	NR	NR	NR	NR	R	NR	NR	NR	NR

Table continues

Subclause in IEEE Std 1547-2018		Subclause in IEEE Std 1547.1									
Subclause number	Title	DE1 - Confirm pertinent type test and operating conditions	DE2 - Confirm with protection and impact study	DE3 - DER unit/system information and fault current review	DE4 - System design review	IE1 - Verify installation matches design evaluation	IE2 - Verify information exchange and input applicable settings	IE3 - Verify state of system	CT1 - On-off test	CT2 - Voltage and frequency tests	CT3 - Power quality tests
		8.4.1.1	8.4.1.2	8.4.1.3	8.4.1.4	8.4.2.1	8.4.2.2	8.4.2.3	8.4.3.1	8.4.3.2	8.4.3.3
5.3.5	Constant reactive power mode	NR	NR	NR	NR	NR	R	NR	NR	NR	NR
5.4.2	Voltage-active power (volt-watt) mode	NR	NR	NR	NR	NR	R	NR	NR	NR	NR
6.2	Area EPS Faults and open phase conditions	R	R	NR	R	NR	NR	NR	D	NR	NR
6.3	Area EPS Reclosing Coordination	R	R	NR	R	NR	NR	NR	NR	NR	NR
6.4.1	Mandatory voltage tripping requirements	R	R	NR	R	NR	R	NR	NR	D	NR
6.4.2.1	General requirements and exceptions	R	NR	NR	NR	R	NR	NR	NR	D	NR
6.4.2.2	Voltage disturbances within continuous operating region	R	NR	NR	NR	R	NR	NR	NR	D	NR
6.4.2.3.2	Low-voltage ride-through capability	R	NR	NR	NR	R	NR	NR	NR	NR	NR
6.4.2.3.3	Low-voltage ride-through performance	R	NR	NR	NR	R	NR	NR	NR	NR	NR
6.4.2.6.1	Dynamic voltage support capability	R	NR	NR	NR	R	NR	NR	NR	NR	NR
6.4.2.6.2	Dynamic voltage support performance	R	NR	NR	NR	R	NR	NR	NR	NR	NR
6.4.2.7.1	Restore output without dynamic voltage support	R	NR	NR	NR	R	NR	NR	NR	NR	NR
6.4.2.7.2	Restore output with dynamic voltage support	R	NR	NR	NR	R	NR	NR	NR	NR	NR
6.4.2.7.3	Transition between performance operating regions for Category III DER	R	NR	NR	NR	R	NR	NR	NR	NR	NR
6.5.1	Mandatory frequency tripping requirements	R	R	NR	NR	NR	R	NR	NR	D	NR
7.2.2	Rapid voltage changes (RVC)	NR	NR	R	R	NR	NR	NR	NR	NR	D
7.2.3	Flicker	NR	NR	R	R	NR	NR	NR	NR	NR	D
7.3	Limitation of current distortion	NR ^a	NR	NR ^a	NR ^a	NR ^c	NR	NR	NR	NR	NR ^b
7.4	Limitation of overvoltage contribution	NR	NR	R	R	R	NR	NR	NR	NR	D
8.1	Unintentional islanding	NR ^a	NR ^a	NR	NR ^a	NR ^c	NR ^c	NR	NR ^b	NR	NR

Table continues

Subclause in IEEE Std 1547-2018		Subclause in IEEE Std 1547.1									
Subclause number	Title	DE1 - Confirm pertinent type test and operating conditions	DE2 - Confirm with protection and impact study	DE3 - DER unit/system information and fault current review	DE4 - System design review	IE1 - Verify installation matches <i>design evaluation</i>	IE2 - Verify information exchange and input applicable settings	IE3 - Verify state of system	CT1 - On-off test	CT2 - Voltage and frequency tests	CT3 - Power quality tests
		8.4.1.1	8.4.1.2	8.4.1.3	8.4.1.4	8.4.2.1	8.4.2.2	8.4.2.3	8.4.3.1	8.4.3.2	8.4.3.3
8.1.2	Conditional extended <i>clearing time</i>	R	R	NR	R	NR	NR	NR	NR	NR	NR
8.1.3	Area EPS with automatic reclosing	R	R	NR	R	NR	NR	NR	NR	NR	NR
9.2	Distribution secondary grid networks	NR	R	NR	R	R	NR	R	D	NR	NR
9.3	Distribution secondary spot networks	NR	R	NR	R	R	NR	R	D	NR	NR
10.1	Interoperability requirements	R	NR	NR	NR	NR	R	NR	NR	NR	NR
10.2	Monitoring, control, and information exchange requirements	R	NR	NR	NR	NR	R	NR	NR	NR	NR

Legend: R = required evaluation or test, D = test dependent on *design evaluation*, NR = no requirement, Shaded = no requirement in IEEE Std 1547-2018.

^aIEEE Std 1547-2018 identifies this test as not required (NR). It is recommended to consider a *design evaluation*.

^bIEEE Std 1547-2018 identifies this test as not required (NR). It is recommended to consider this *Commissioning test* depending on *design evaluation*.

^cIEEE Std 1547-2018 identifies this test as not required (NR). It is recommended to consider an *installation evaluation*.

8.4.1 Basic DER *design evaluation* for PCC system

The DER *design evaluation* is conducted during the design of the system, generally after the equipment selection has been finalized. During this evaluation, consideration is also given to *area EPS operator* interconnection practices, regulatory requirements, and local codes. As the outcome of the *design evaluation*, the compliance to the IEEE 1547 requirements is determined as well as determination of any additional and necessary *installation evaluation* and/or *commissioning tests* needed to verify compliance to IEEE Std 1547.

8.4.1.1 *Design evaluation* DE1: Confirm pertinent *type test* and operating conditions

8.4.1.1.1 Purpose

The purpose of this evaluation is to confirm that the *type tests* and *production test* requirements are met by the *DER unit/system*. Additionally, it is to make determination of the *reference point of applicability* (RPA) and whether the *DER unit/system* is fully or partially compliant. Confirmation of these requirements shall be achieved by reviewing project documentation, certification, pertinent regulatory requirements, and other pertinent documentation.

8.4.1.1.2 Requirements

This evaluation shall be performed when the *DER unit/system* has been selected for the application. The type-test results summary document for the *DER unit/system* issued by the *testing agency* shall be used for the evaluation. The *DER unit/system* datasheet shall be used to determine compliance to the system operation conditions.

8.4.1.1.3 Procedure

The procedure is as follows:

- a) Review pertinent IEEE 1547 *type test* and certification details, and nameplate information of *DER unit/system*. Verify compliance against owner's project requirements (OPR), project specifications, and regulatory requirements.
- b) Verify that the operating conditions including, but not limited to, the altitude, operating and storage temperatures, of the application are within the specification of the *DER unit/system*.
- c) For a *DER unit/system*, verify that the *DER unit/system* is installed in accordance with the DER manufacturer's instructions.¹²⁹
- d) Verify that the *DER unit/system* design is fully compliant with the manufacturer's application requirements and limitations, and is implemented within the limits of its *type test*. Limitations may include maximum effective impedance between *DER units* and the PCC and the efficacy of any *plant controller* to meet requirements at the PCC.

¹²⁹For example, a substantial difference from the manufacturer's instructions for the type tested system may invalidate the fully compliant classification of the *DER system*.

8.4.1.1.4 Criteria

The evaluation shall verify that the *DER unit/system* selected has completed and passed the *type tests* for the requirements of the application. The results of this evaluation may identify any required *installation evaluation* or *commissioning test* in order to fully comply with the IEEE 1547 requirements.

The evaluation shall also verify that the application operation conditions are within the specification of the *DER unit/system*.

8.4.1.2 Design evaluation DE2: Confirm with protection and impact study

8.4.1.2.1 Purpose

If a protection or impact study is required, the purpose of this evaluation is to confirm and coordinate the *DER unit/system* protection and control settings with the results from these studies.

8.4.1.2.2 Requirements

This evaluation shall be performed once the equipment performing the IEEE 1547 functions has been selected. *DER unit/system* protection settings shall be coordinated once results from the protection and impact study are available.

8.4.1.2.3 Procedure

The procedure is as follows:

- a) Confirm that the *DER system* interconnects according to the integration with *area EPS* grounding requirement in 4.12 of IEEE Std 1547-2018. Refer to IEEE Std C62.92.1 for definitions of grounding and to IEEE Std C62.92.6 for guidance on grounding of inverter-coupled DERs.¹³⁰
- b) Confirm that *area EPS* reclosing coordination meets requirements in 6.3 in IEEE Std 1547-2018.
- c) Using the results from the protection study, adjust the voltage and frequency protection settings of *DER unit/system*, including, but not limited to, mandatory voltage trip settings and mandatory frequency trip settings.
- d) Confirm that the fault current contribution from the *DER unit/system* does not adversely affect the function and operation of the protection equipment in the surrounding circuits.
- e) If the DER is connected to a secondary grid or spot network, confirm that the DER is implemented as required in Clause 9 of IEEE Std 1547-2018 and will not cause misoperation of any network protector(s) or exceed any network protector rating.

8.4.1.2.4 Criteria

The *DER unit/system* shall be considered in compliance if the *DER unit/system* voltage and frequency protection settings match the resulting settings from the protection and impact studies. Any mismatch necessitates settings adjustment during DER installation.

¹³⁰Additional consideration may be given to cases that may not have been considered in IEEE Std C62.92.6.

8.4.1.3 *Design evaluation* DE3: DER information and fault current review

8.4.1.3.1 Purpose

The purpose of this evaluation is to provide the *area EPS operator* with information that may be used to evaluate impact of *DER unit/system* connection onto the *area EPS*. The system model and fault current review, along with other protection and impact study tools, are used to confirm whether voltage deviations including voltage fluctuations induced by the DER, rapid voltage changes, flicker, and limitation of overvoltage contribution meet IEEE 1547 requirements.

8.4.1.3.2 Requirements

This evaluation shall be performed during interconnection application process and once the *DER unit/system* has been selected.

8.4.1.3.3 Procedure

The interconnection application submitted to the *area EPS operator* shall provide information to evaluate the impact of the *DER unit/system* on the *area EPS*. This information may include, but is not necessarily limited to, the following:

- a) Electrical model of *DER unit/system* in a form as required by *area EPS operator*. Where generally accepted generic models for the DER type exist, providing model parameters rather than actual models may be acceptable.
- b) Electrical one-line diagram describing specification and characteristics of the electrical and DER equipment used in the *DER unit/system*.
- c) Fault current contribution from the *DER unit/system*.
 - 1) For rotating machine technologies, this is typically in the form of impedance characteristics of the generator. See 5.18.2.1, 5.18.2.2, and 5.18.2.3 for reference.
 - 2) For inverter technologies, this is in the form of oscillographic representation of the fault currents and voltages. See 5.18.1 for reference.

8.4.1.3.4 Criteria

The *DER unit/system* shall be considered in compliance if the model and fault current information has successfully been submitted for study and results are determined acceptable by the *area EPS operator*. Any non-compliance shall be identified and will necessitate corrective action.

8.4.1.4 *Design evaluation* DE4: System design review

8.4.1.4.1 Purpose

The purpose of this evaluation is to review that the application of the type tested *DER unit/system* complies with the IEEE 1547 requirements. Confirmation of compliance shall be achieved by reviewing project design documentation.

8.4.1.4.2 Requirements

The evaluation shall be performed when the *DER unit/system* has been selected. The design review shall be on-going through-out completion of project design.

8.4.1.4.3 Procedure

The procedure is as follows:

- a) Confirm that the *DER unit/system* designed provides the means to measure, or otherwise determine, voltage and other parameters as necessary, and delivers compliance with all IEEE 1547 requirements at the PCC.
- b) Confirm the following operating modes and settings requirements from *area EPS operator*¹³¹ and review that the *DER unit/system* is capable the required performance.
 - 1) Enter service criteria: Enter service voltage and frequency settings, minimum intentional delay and rate-of-change of the active power.
 - 2) Voltage and reactive/active power control.
 - 3) Mandatory voltage and frequency tripping setpoints.
 - 4) Voltage regulation and ride-through performance categories.
 - 5) Dynamic voltage support.
 - 6) Frequency-droop control parameters.
 - 7) Inertial response, if required by *area EPS operator*.
 - 8) Islanding.¹³²
 - Verify that the design implements the unintentional islanding required by the *area EPS operator*.¹³³
 - If intentional islanding is required, confirm if *DER unit/system* shall apply different control and protection settings.
 - If *area EPS operator* does not specify operating mode, *DER unit/system* shall be set to default mode.
- c) Confirm that the *DER unit/system* and equipment could not energize the *area EPS* when it is de-energized.
- d) Review grounding scheme of *DER unit/system* and confirm that it is in coordination with the ground fault protection of the *area EPS*.
- e) When required by the *area EPS operator* and by performing a system impact study, evaluate the *DER unit/system* for impact on power quality of *area EPS* to which it is connected.¹³⁴ This *design evaluation* may indicate risk of exceeding the required limit. In this case, *commissioning test* may be needed.
 - 1) Evaluate equipment and/or operation that may cause RVC such as energization of transformers, switching of capacitor banks for reactive power support, or abrupt change in power output.¹³⁵

¹³¹Such document may be referred to as a Utility Requirements Document by certain *area EPS operators*.

¹³²Additional DER integration issues may need to be evaluated for all *island* detection methods, including interactions of combinations of islanding detection methods on the same *area EPS*.

¹³³Some unintentional islanding methods that were type tested may only be partially compliant and when installed may require specific implementation of field devices. In this scenario, the end-to-end implementation the unintentional islanding method should be evaluated and may require commissioning testing.

¹³⁴Under specific conditions as specified in subclause 4.2 of IEEE Std 1547-2018, the power quality requirements in Clause 7 of IEEE Std 1547-2018 may be evaluated excluding the influence of the *local EPS* load.

¹³⁵Sequencing of equipment operation such as energization of transformers, controlled ramp-up of output power and smaller step changes of capacitor banks may aid in reducing the magnitude of RVC.

To measure voltage for RVC at the PCC, use appropriate measurement devices that are capable of capturing rms voltage on one cycle basis.

The RVC limits shall not apply to infrequent events such as switching, unplanned tripping, or transformer energization related to commissioning, fault restoration or maintenance, however an RVC evaluation may be performed to understand the impact on the *area EPS*.

- 2) Evaluate flicker results from DER equipment *type test* and any loads in the *DER unit/system* that may cause flicker. Using the DER equipment *type test* results, summation law in IEC/TR 61000-3-7 may be used to evaluate the potential flicker cause by the *DER unit/system*. Alternatively, IEC 61400-21 defines flicker coefficient for certain types of power generation devices and provides methods to predict for potential flicker based on the grid characteristics at the PCC.
- 3) Identify equipment that may potentially be harmonic sources and/or loads and evaluate current distortion results from DER equipment *type test*. Individual harmonic source contributions may be combined using the harmonic summation laws in IEC 61000-3-6.

DER that meet current distortion limits when connected to an undistorted external system, such as during type testing, may exceed current distortion limits when connected to a field environment having voltage distortion. IEEE 1547 limitations on harmonic current distortion specifically exclude harmonic currents due to *area EPS* voltage distortion not caused by the DER. Such ambient distortion is invariably present, thus making difficult or impossible the task of evaluation distortion compliance in the field.

Design evaluation may indicate risk of exceeding the current distortion requirement and in this case, the current distortion shall be measured during the commissioning of the *DER unit/system*. If the current distortion exceeds the limits allowed in IEEE Std 1547, DER owner shall determine the appropriate resolution.

- 4) If the GFOV and LROV tests were performed on the *DER unit*, the results obtained from that *type tests* can be used to evaluate the effect of the DER on the *area EPS* overvoltage limits as defined in 7.4.1 of IEEE Std 1547.¹³⁶

8.4.1.4.4 Criteria

The application of the *DER unit/system* shall be considered in compliance if it has been evaluated and confirmed meeting the IEEE 1547 and project requirements. Any non-compliance shall be identified and will necessitate corrective action during DER installation and commissioning.

8.4.2 Basic DER *installation evaluation* for PCC system

The basic DER *installation evaluation* is conducted on-site after the equipment is delivered and significantly installed. This is an evaluation prior to the time of commissioning and generally when there is still opportunity for corrective action if any non-compliance is identified.

8.4.2.1 *Installation evaluation* IE1: Verify installation matches *design evaluation*

8.4.2.1.1 Purpose

The purpose of this evaluation is to verify that the equipment installed is that evaluated under the DER *design evaluation*. The evaluation shall determine whether the *DER unit/system* complies with the pertinent

¹³⁶The results of the tests may inform evaluation of the need for supplemental grounding sources in certain applications.

IEEE 1547 requirements identified in this subclause by verifying that the specified equipment with correct parameters and configurations has been installed.

In addition, any corrective actions identified in the DER *design evaluation* shall be verified as complete.

The purpose of this evaluation is also to confirm continuity of the end-to-end physical wiring from the DER *plant controller* to the measurement devices and DER equipment providing the IEEE 1547 functions. The *DER unit/system* may be comprised of *plant controller* that controls multiple DER equipment, and receives measurement from devices that measures various parameters such as voltage, current, active and reactive powers. These devices have been type tested together as a system and comply with the requirements of IEEE Std 1547.

The procedures included in this subclause also verify correct application of external inputs to the *DER unit/system* such as the permit service setting and active power limit, which may be received by the *DER unit/system* via communication interface or hardwire digital or analog signals.

8.4.2.1.2 Requirements

This *installation evaluation* shall be performed when the major DER equipment has been installed and prior to commissioning. Alternatively, this *installation evaluation* may be performed on an on-going basis through-out completion of project installation.

Some of the procedures may require availability of the *DER unit/system* control power to access the DER plant and/or unit controller board and interface.

8.4.2.1.3 Procedure

The procedure is as follows:

- a) Review the results of the DER *design evaluation* and project documentation for information specifically related to DER's project-specific settings and configurations.
- b) Confirm that equipment on site is that used in the basic DER *design evaluation*, matches project documentation and installed in accordance with the DER manufacturer's instructions. This is done by confirming that nameplate data of installed equipment matches that identified in the *design evaluation* and project documentation. Nameplate data includes model number, serial number, configuration information, and other parameters.
- c) Verify that the *DER unit/system* installed is connected to the correct PCC per design.
- d) Verify installation of grounding scheme and wiring per *DER unit/system* design.
- e) If required by the *area EPS operator*, verify isolation device between the *DER unit/system* and *area EPS* and implementation for accessible, lockable and visible break device and is clearly marked accordingly.
- f) Any corrective action identified in the design review should be checked for completion. Results of this evaluation shall be documented, highlighting acceptance or failure and any corrective actions needed should be highlighted.

8.4.2.1.4 Criteria

Confirmation of these requirements shall be achieved by reviewing the results of the *design evaluation* and inspecting the *DER unit/system* as installed to verify the installation and configuration matches that of the project documentation and the design review.

IS 18969 : 2024

The *DER unit/system* shall be considered in compliance if the DER installed matches the system as evaluated in the *design evaluation*.

Failure of the documentation and inspection to demonstrate that the installation matches the *design evaluation* may result in corrective actions needing completion before commissioning of the *DER unit/system*.

8.4.2.2 Installation evaluation IE2: Verify information exchange and input applicable settings

8.4.2.2.1 Purpose

The purpose of this evaluation is to confirm the availability of information of the *DER unit/system* via the local DER communication interface and that the IEEE 1547 pertinent system settings are applied per the requirements listed below and project documentation. Confirmation of this shall be achieved by reviewing the actual settings in the installed equipment and verifying them against the settings provided in project documentation.

In addition, this subclause verifies and documents the DER equipment software and firmware revisions or any need for upgrade from the default revision.

The procedures below require availability of the *DER unit/system* control power to access the DER plant and/or unit controller board and interface.

8.4.2.2.2 Requirements

This *installation evaluation* shall be performed when the DER installation is nearing completion and the control system of the pertinent DER equipment can be energized.

8.4.2.2.3 Procedure

The procedure is as follows:

- a) Review the results of the *design evaluation* and project documentation for information specifically related to *DER unit/system* project-specific settings.
- b) Verify that the *DER unit/system* is capable of communicating with the *area EPS operator*. The availability of the parameters listed in 10.3 through 10.6 of IEEE Std 1547-2018 would have been verified in the *DER unit/system type test*.
- c) The following settings shall be confirmed with the *area EPS operator* and shall be adjusted in the DER devices or the *DER plant controller* accordingly. If not specified by *area EPS operator*, default values as specified in IEEE Std 1547 shall be used.
 - 1) Enter service parameters:
 - i) Enter service adjustable time delay
 - ii) Enter service adjustable time period
 - iii) Enter service maximum active power increase of any single step
 - 2) Voltage and reactive power control mode:

- i) Either constant power factor mode, voltage-reactive power mode, active power-reactive power mode or constant reactive power mode. If not specified by *area EPS operator*, default mode is constant power factor mode.
 - ii) If constant power factor mode is selected, apply the power factor setting.
 - iii) If voltage-reactive power mode is selected, apply the voltage-reactive power parameters per Table 8 of IEEE Std 1547-2018.
 - iv) If active power-reactive power mode, apply the active power-reactive power parameters per Table 9 of IEEE Std 1547-2018.
 - v) If constant reactive power mode is selected, apply the reactive power setting.
- 3) Voltage and active power control mode:
- i) Enable voltage-active power mode if specified by *area EPS operator*. If not specified, default mode is disabled.
 - ii) If voltage-active power mode is selected, apply the voltage-active power parameters per Table 10 of IEEE Std 1547-2018.
- 4) Response to *area EPS* abnormal voltages
- i) Ride-through performance category
 - ii) Voltage trip and *clearing time* settings for Category I, II, or III, accordingly.
- 5) Response to *area EPS* abnormal frequencies
- i) Ride-through performance category
 - ii) Frequency trip and *clearing time* settings for Category I, II, or III, accordingly.
 - iii) Frequency-droop parameters per Table 24 of IEEE Std 1547-2018.
- d) Verify that these parameters can be adjusted locally and/or remotely as specified by the *area EPS operator*. If remotely, verify that the remote controller or access can provide the settings and that the DER equipment received the settings. This verifies the continuity of the end-to-end communication wiring.
- e) Once completed, settings adjustments shall be recorded and provided to *area EPS operator* for confirmation and reference.
- f) In the distribution secondary grid network, coordinate *DER unit/system* protection settings with the network protector relay function, and confirm with *area EPS operator*.
- g) Verify the DER equipment software and firmware revision and confirm with the *DER unit/system* manufacturer of the revisions that meet the IEEE 1547 requirements.
- h) If any upgrade is required, verify that correct parameters and settings are applied to the upgraded software and firmware revision. It is advisable that the *DER operator* is aware and understand the changes of the software or firmware revisions to evaluate the impact of the changes to the *DER unit/system* operation. This may be accomplished by means including, but not limited to, requesting the design change documentation, integration with *DER unit/system*, evaluating impact and performing bench test of the *DER unit/system* controls and operation.

8.4.2.2.4 Criteria

The *DER unit/system* shall be considered in compliance if the application of settings as specified by *area EPS operator* has been completed. If not specified, default settings shall be applied. Any non-compliance shall be corrected. Once completed, settings adjustments shall be recorded and provided to *area EPS operator* for confirmation and reference.

The *DER unit/system* shall be considered in compliance if it contains the software and firmware revision that meets the IEEE 1547 requirements. If any software and/or firmware upgrade is required, performance of the *DER unit/system* after the upgrade shall still meet the IEEE 1547 requirements.

8.4.2.3 *Installation evaluation* IE3: Verify state of system

8.4.2.3.1 Purpose

The purpose of this evaluation is to verify state of *DER unit/system* when the system is energized with control power and prior to system start-up.

8.4.2.3.2 Requirements

This *installation evaluation* shall be performed when the *DER unit/system* installation is completed and the control system of the pertinent DER equipment can be energized.

8.4.2.3.3 Procedure

The procedure is as follows:

- a) With the *DER unit/system* deenergized and control power to *DER unit/system* available, command the *DER unit/system* to start-up. *DER unit/system* can be in the deenergized state if the main system switchgear is in open position and *DER unit/system* is not connected to the *area EPS*.
- b) In the distribution secondary spot network, verify that the *area EPS* network bus is energized by more than 50% of the installed network protector prior to permitting the connection of the *DER unit/system* to the *area EPS*.

8.4.2.3.4 Criteria

The *DER unit/system* shall be considered in compliance if the *DER unit/system* does not proceed to start and energize the *area EPS* when *area EPS* is not energized.

For a *DER unit/system* installed in a secondary network, the *DER unit/system* shall also be considered in compliance if the connection of the *DER unit/system* to *area EPS* is only permitted if *area EPS* network is already energized by more than 50% of the installed network protector.

8.4.3 Basic DER *commissioning tests* for PCC system

The basic DER *commissioning tests* are conducted after installation of the system has been completed, all de-energized checks have been passed and the system has been approved for energization. In addition to the tests outlined in this subclause, any tests determined from the design and *installation evaluation* shall be performed as part of the *commissioning test* to verify compliance. Once the *DER unit/system* has completed the commissioning activities and prior to continuous operation, as-built *DER unit/system* configuration and commissioning results shall be documented and submitted to the *area EPS operator*.

8.4.3.1 Commissioning Test CT1: On-off test

8.4.3.1.1 Purpose

The purpose of this test is to evaluate the impact of *DER unit/system* energization and operation on the *area EPS*. The *DER unit/system* shall be brought online, operated up to the maximum available capacity,¹³⁷ and go through planned and unplanned shutdown sequences.

8.4.3.1.2 Requirements

This test shall be performed when the *DER unit/system* has passed deenergized and pre-energization checks and has been approved for energization and operation at the specified operating modes. The *area EPS operator* may require representation during initial energization and during the testing of *DER unit/system*.

8.4.3.1.3 Procedure

The description outlined in this subclause are recommended actions. Tests shall be performed as required by, and to the satisfaction of, the *area EPS operator*. Detail test procedures shall be developed in coordination with the *DER unit/system* designer and equipment manufacturer.

- a) When the *area EPS* is de-energized, observe that the *DER unit/system* does not energize the *area EPS*,
- b) With the *DER unit/system* in the OFF state, bring the *DER unit/system* online. The *DER unit/system* shall be set to the specified operating mode, active, reactive power or power factor setpoints. Confirm that the *DER unit/system* starts to come online (delivering power into *area EPS*) or makes connection to the *area EPS* when the *DER unit/system* voltage and frequency are within range specified in Table 4 or Table 5 of IEEE Std 1547-2018, and permit service is enabled. During the start-up of the *DER unit/system*, observe the *area EPS* voltage response (transient and steady-state), any intentional delay and power ramping until the *DER unit/system* reaches a steady-state operation. Simulate a disconnect and reconnect condition and observe the return to service of the *DER unit/system*. This may be achieved by means including, but not limited to, manually triggering a disconnect of the *DER unit/system* from the *area EPS* using a device other than the interconnection device that provides the cease-to-energize function or creating a temporary abnormal condition by adjusting the voltage trip settings to cause a disconnect. Once the *DER unit/system* is disconnected, this parameter is reversed to allow for reconnect or return to service.
- c) With the *DER unit/system* operating and generating power, the *DER unit/system* shall be verified for response to external inputs including permit service, active power limit and operating modes. These inputs shall be provided at the external input connection point.
- d) Perform any other tests determined to be necessary by the DER and *area EPS operator* as the outcome from the *design evaluation*.

8.4.3.1.4 Criteria

Observe the *area EPS* response and *DER system* stability. Review observation with *area EPS operator* and perform any adjustment to operating parameters/setpoints in coordination with *area EPS operator* as necessary.

¹³⁷For installations that are dependent on input source environmental variability such as solar, wind and renewable fuel installations, *DER system* needs to be operated up to the available capacity at the time of test or as agreed with *area EPS operator*.

8.4.3.2 Commissioning Test CT2: Voltage and frequency tests

8.4.3.2.1 Purpose

The purpose of this test is to verify the abnormal voltage and frequency response of the *DER unit/system*. The *DER unit/system* shall be in compliance with the response to *area EPS* abnormal conditions requirements and verification may consist of *commissioning test* as required by the *area EPS operator*. The impact of the DER response to the *area EPS* shall be observed.

8.4.3.2.2 Requirements

This test shall be performed when the *DER unit/system* has passed deenergized and pre-energization checkouts, has been approved for energization and operation at the specified operating modes and has achieved stable operation at the specified operating conditions. The *area EPS operator* may require representation during initial energization and during the testing of the DER.

8.4.3.2.3 Procedure

The need for *commissioning tests* for *DER unit/system* with RPA at the PCC is as displayed in [Table 74](#). The need for any *commissioning test* is determined in the *design evaluation*. Tests shall be performed as required by the *area EPS operator* with details determined by mutual agreement between the *DER operator* and EPS operator.

The response to *area EPS* abnormal voltage and frequency conditions are performed by the *DER unit/system* which are type tested and approved for these functions. Due to complication of performing abnormal voltage and frequency tests in the field, *design evaluation* and *installation evaluation* should have been performed prior to the commissioning phase for the purpose of evaluating conformance of the *DER unit/system* to the *area EPS* abnormal voltage and frequency requirements and settings coordination. *Signal injection test method* may be considered if the *DER composite* or devices have the provision for this method. Adjustment of the shall-trip settings may be considered if verification of the mandatory trip function is required.

8.4.3.2.4 Criteria

The *DER unit/system* shall be considered in compliance if it demonstrated that it meets the required abnormal voltage and frequency response, magnitude and *clearing time* requirements. Verification of compliance to this requirement may be achieved by a combination of *design evaluation*, *installation evaluation*, and *commissioning test* as accepted by the *area EPS operator*. Observe the DER response. Review observation with *area EPS operator* and perform any adjustment to operating parameters/setpoints in coordination with *area EPS operator* as necessary.

8.4.3.3 Commissioning Test CT3: Power quality tests

8.4.3.3.1 Purpose

The purpose of this test is to verify that the impact of the *DER unit/system* operation to the *area EPS* power quality are within the specified limit. Any of the power quality tests in the field shall be conducted if any field operational and performance issues arise, determined required from the *design evaluation* and if required by the *area EPS operator*.

Test cases and procedures shall be agreed with *area EPS operator* and may include evaluation at various conditions including *DER unit/system* startup, disconnect and shutdown, full operating range of the *DER unit/system* as well as external conditions such as cloud coverage for solar plants and operation of other nearby facilities. The performance of the *DER unit/system* for power quality may be continuously observed by the *area EPS operator*.

8.4.3.3.2 Requirements

This test shall be performed when the *DER unit/system* has passed deenergized and pre-energization checkouts and has been approved for energization and operation at the specified operating modes. The *area EPS operator* may require representation during initial energization and during the testing of the *DER unit/system*.

Under specific conditions as specified in 4.2 of IEEE Std 1547-2018, the power quality requirements in Clause 7 of IEEE Std 1547-2018 may be evaluated excluding the influence of the *local EPS* load.

The measurement equipment used for power quality tests shall be compliant with IEC 61000-4-30 Class A.

8.4.3.3.3 Procedure

The description outlined in this subclause are recommended actions. Tests shall be performed if power quality issues arise or as required by and agreed with the *area EPS operator*. Detail test procedures shall be developed in coordination with the DER designer and equipment manufacturer.

- a) The power quality requirements shall be measured and met at the *point of common coupling* with the *area EPS*. Connect the measurement equipment at the PCC connection between the *DER unit/system* and the *area EPS*. The measurement equipment shall be capable of measuring ac, dc, rms, instantaneous and harmonic content of the voltages, currents, and frequency. A flicker meter may be used to measure any flicker contribution.
- b) Once the setup of measurement devices is complete, perform measurement of the *DER unit/system* operated under the following conditions:
 - 1) During start-up of the *DER unit/system*, energize (close in) the step-up transformers. Observe impact on the energization in-rush current to the *area EPS*.¹³⁸
 - 2) Turn-on *DER unit/system* and sweep the active and reactive power from 0 to full power,¹³⁹ exercising (switch in and out) any sources of active and reactive power (such as capacitor banks). Observe impact to the *area EPS*.
 - 3) Perform a disconnect event that causes a step change in power delivery (not a soft shutdown, i.e., ramp down of power). Observe impact to the *area EPS*.¹⁴⁰
 - 4) Observe power quality of *area EPS* over a duration of time to capture nominal operating condition of the *DER unit/system*. The conditions would include, but not limited to, cloud coverage for solar DER, operation of other generation and load sources connected to the *area EPS*.

¹³⁸RVC limits in IEEE Std 1547 do not apply for infrequent transformer energizations, or energizations related to maintenance, outage restoration or commissioning.

¹³⁹For installations that are dependent on input source environment variability such as solar, wind and renewable fuel installations, *DER system* may be operated up to the available capacity at the time of test or as agreed with the *area EPS operator*.

¹⁴⁰RVC limits in IEEE Std 1547 only apply to frequent and abrupt voltage variations that take place over a timespan of one second.

8.4.3.3.4 Criteria

The *DER unit/system* is considered in compliance if the impact of the *DER unit/system* operation to the *area EPS* power quality is within the specified limit. Review observation with *area EPS operator* and apply any mitigation action as necessary.

8.5 PCC-Composite: Detailed *DER evaluations* and *commissioning tests* for *DER composite* with RPA at PCC

This subclause describes the detailed verification process for a *DER composite* system that has the RPA at the PCC. A *DER composite* system consists of *DER units* and requires supplemental devices to be compliant with the requirements of the standard.

The list of *design evaluations*, *installation evaluations* and *commissioning tests* outlined in this subclause are provided as a recommendation. Specific evaluations and tests shall be performed in accordance with *area EPS operator* interconnection requirements.

In addition to the procedures described in 8.1.4.1 that are required for all system evaluation, the content in this subclause shall be considered.

Table 75 summarizes the relevant IEEE 1547 requirements that should be verified and indicates with an *R* that the step is required to be verified by the evaluation or test in the applicable column. Note that the *commissioning test* requirement indicated with a *D* in the column is determined during the *design evaluation* review step.

Table 75—Verification Summary for PCC Composites

Subclause in IEEE Std 1547-2018		Subclause in IEEE Std 1547.1												
Subclause number	Title	DE1 – Confirm pertinent type test and operating conditions met	DE2 – Confirm system information and fault current review	DE3 – Confirm with protection and impact study	DE4 – System design review	IE1 – Verify installation matches design evaluation	IE2 – Verify information exchange and input applicable settings	IE3 – Verify state of system	CT1 – On-off test	CT2 – Reactive power capability and control verification	CT3 – Voltage and frequency tests	CT4 – Power quality tests	CT5 – Interoperability tests	CT6 – Islanding test
		8.5.1.1	8.5.1.2	8.5.1.3	8.5.1.4	8.5.2.1	8.5.2.2	8.5.2.3	8.5.3.1	8.5.3.2	8.5.3.3	8.5.3.4	8.5.3.5	8.5.3.6
4.2	Reference points of applicability	R	NR	NR	R	R	NR	NR	NR	NR	NR	NR	NR	NR
4.3	Applicable voltages	R	NR	NR	R	R	NR	NR	NR	NR	NR	NR	NR	NR
4.4	Measurement accuracy	R	NR	NR	R	R	NR	NR	NR	NR	NR	NR	NR	NR
4.5	Cease-to-energize performance requirement	R	NR	NR	R	NR	R	NR	D	NR	NR	NR	NR	NR
4.6.1	Capability to disable permit service	R	NR	NR	R	R	R	NR	D	NR	NR	NR	NR	NR
4.6.2	Capability to limit active power	R	NR	NR	R	R	NR	NR	D	NR	NR	NR	NR	NR
4.6.3	Execution of mode or parameter changes	R	NR	NR	R	R	NR	NR	NR	D	NR	NR	NR	NR
4.7	Prioritization of DER responses and execution of mode or parameter changes	R	NR	NR	R	NR	R	NR	D	D	D	NR	NR	NR
4.8	Isolation device	NR	NR	NR	NR	R	NR	NR	D	NR	NR	NR	NR	NR
4.9	Inadvertent energization of the <i>area EPS</i>	R	NR	NR	R	NR	NR	R	D	NR	NR	NR	NR	D
4.10.2	Enter service criteria	R	NR	NR	R	R	R	NR	D	NR	NR	NR	NR	NR
4.10.3	Performance during entering service	R	NR	NR	R	NR	R	NR	D	NR	NR	NR	NR	NR
4.10.4	Synchronization	R	NR	NR	R	R	NR	NR	D	NR	NR	NR	NR	NR
4.12	Integration with <i>area EPS</i> grounding	R	NR	R	R	R	NR	NR	NR	NR	NR	NR	NR	NR
5.2	Reactive power capability of the DER	R	NR	NR	R	R	NR	NR	NR	D	NR	NR	NR	NR
5.3	Voltage and reactive power control	R	NR	NR	R	NR	R	NR	NR	D	NR	NR	NR	NR
5.3.2	Constant power factor mode	R	NR	NR	R	NR	R	NR	NR	D	NR	NR	NR	NR
5.3.3	Voltage-reactive power (volt-var) mode	R	NR	NR	R	NR	R	NR	NR	D	NR	NR	NR	NR
5.3.4	Active power-reactive power (watt-var or <i>P-Q</i>) mode	R	NR	NR	R	NR	R	NR	NR	D	NR	NR	NR	NR
5.3.5	Constant reactive power mode	R	NR	NR	R	NR	R	NR	NR	D	NR	NR	NR	NR

Table continues

Subclause in IEEE Std 1547-2018		Subclause in IEEE Std 1547.1												
Subclause number	Title	DE1 – Confirm pertinent type test and operating conditions met	DE2 – Confirm system information and fault current review	DE3 – Confirm with protection and impact study	DE4 – System design review	IE1 – Verify installation matches design evaluation	IE2 – Verify information exchange and input applicable settings	IE3 – Verify state of system	CT1 – On-off test	CT2 – Reactive power capability and control verification	CT3 – Voltage and frequency tests	CT4 – Power quality tests	CT5 – Interoperability tests	CT6 – Islanding test
		8.5.1.1	8.5.1.2	8.5.1.3	8.5.1.4	8.5.2.1	8.5.2.2	8.5.2.3	8.5.3.1	8.5.3.2	8.5.3.3	8.5.3.4	8.5.3.5	8.5.3.6
5.4.2	Voltage-active power (volt-watt) mode	R	NR	NR	R	NR	R	NR	NR	D	NR	NR	NR	NR
6.2	Area EPS faults and open phase conditions	R	NR	R	R	NR	R	NR	D	NR	NR	NR	NR	D
6.3	Area EPS Reclosing Coordination	R	NR	R	R	NR	NR	NR	D	NR	NR	NR	NR	D
6.4.1	Mandatory voltage tripping requirements	R	NR	R	R	NR	R	NR	NR	NR	D	NR	NR	NR
6.4.2.1	General requirements and exceptions	R	NR	NR	R	R	NR	NR	NR	NR	D	NR	NR	NR
6.4.2.2	Voltage disturbances w/in continuous operating region	R	NR	NR	R	R	NR	NR	NR	NR	D	NR	NR	NR
6.4.2.3.2	Low-voltage ride-through capability	R	NR	NR	R	R	NR	NR	NR	NR	D	NR	NR	NR
6.4.2.3.3	Low-voltage ride-through performance	R	NR	NR	R	R	NR	NR	NR	NR	D	NR	NR	NR
6.4.2.4.2	High-voltage ride-through capability	R	NR	NR	R	R	NR	NR	NR	NR	D	NR	NR	NR
6.4.2.4.3	High-voltage ride-through performance	R	NR	NR	R	R	NR	NR	NR	NR	D	NR	NR	NR
6.4.2.5	Ride-through of consecutive voltage disturbances	R	NR	NR	R	R	NR	NR	NR	NR	D	NR	NR	NR
6.4.2.6.1	Dynamic voltage support capability	R	NR	NR	R	R	NR	NR	NR	NR	D	NR	NR	NR
6.4.2.6.2	Dynamic voltage support performance	R	NR	NR	R	R	NR	NR	NR	NR	D	NR	NR	NR
6.4.2.7.1	Restore output without dynamic voltage support	R	NR	NR	R	R	NR	NR	NR	NR	D	NR	NR	NR
6.4.2.7.2	Restore output with dynamic voltage support	R	NR	NR	R	R	NR	NR	NR	NR	D	NR	NR	NR
6.4.2.7.3	Transition between performance operating regions for Category III DER	R	NR	NR	R	R	NR	NR	NR	NR	D	NR	NR	NR
6.5.1	Mandatory frequency tripping requirements	R	NR	R	R	NR	R	NR	NR	NR	D	NR	NR	NR
6.5.2.1	General requirements and exceptions	R	NR	NR	R	R	NR	NR	NR	NR	R ^a	NR	NR	NR
6.5.2.2	Frequency disturbances within continuous operation region	R	NR	NR	R	R	NR	NR	NR	NR	R ^a	NR	NR	NR
6.5.2.3.2	Low-frequency ride-through performance	R	NR	NR	R	R	NR	NR	NR	NR	R ^a	NR	NR	NR
6.5.2.4.1	High-frequency ride-through capability	R	NR	NR	R	R	NR	NR	NR	NR	R ^a	NR	NR	NR

Table continues

Subclause in IEEE Std 1547-2018		Subclause in IEEE Std 1547.1												
Subclause number	Title	DE1 – Confirm pertinent type test and operating conditions met	DE2 – Confirm system information and fault current review	DE3 – Confirm with protection and impact study	DE4 – System design review	IE1 – Verify installation matches design evaluation	IE2 – Verify information exchange and input applicable settings	IE3 – Verify state of system	CT1 – On-off test	CT2 – Reactive power capability and control verification	CT3 – Voltage and frequency tests	CT4 – Power quality tests	CT5 – Interoperability tests	CT6 – Islanding test
		8.5.1.1	8.5.1.2	8.5.1.3	8.5.1.4	8.5.2.1	8.5.2.2	8.5.2.3	8.5.3.1	8.5.3.2	8.5.3.3	8.5.3.4	8.5.3.5	8.5.3.6
6.5.2.4.2	High-frequency ride-through performance	R	NR	NR	R	R	NR	NR	NR	NR	R ^a	NR	NR	NR
6.5.2.5	Rate of change of frequency (ROCOF) ride-through	R	NR	NR	R	R	NR	NR	NR	NR	R ^a	NR	NR	NR
6.5.2.6	Voltage phase angle changes ride-through	R	NR	NR	R	NR	NR	NR	NR	NR	D	NR	NR	NR
6.5.2.7.1	Frequency-droop (frequency-power) capability	R	NR	NR	R	R	R	NR	NR	NR	D	NR	NR	NR
6.5.2.7.2	Frequency-droop (frequency/power) operation	R	NR	NR	R	R	R	NR	NR	NR	D	NR	NR	NR
6.6	Return to service after trip	R	NR	NR	R	R	R	NR	D	NR	D	NR	NR	NR
7.1	Limitation of dc injection	NR	NR	NR	R	R	NR	NR	NR	NR	NR	NR ^a	NR	NR
7.2.2	Rapid voltage changes (RVC)	NR	R	NR	R	NR	NR	NR	NR	NR	NR	D	NR	NR
7.2.3	Flicker	NR	R	NR	R	NR	NR	NR	NR	NR	NR	D	NR	NR
7.3	Limitation of current distortion	R	R	NR	R	R	NR	NR	NR	NR	NR	D	NR	NR
7.4	Limitation of overvoltage contribution	NR	R	NR	R	R	NR	NR	NR	NR	NR	D	NR	NR
8.1	Unintentional islanding	R	NR	R	R	R	R	NR	NR	NR	NR	NR	NR	R
8.1.2	Conditional extended clearing time	R	NR	R	R	R	NR	NR	NR	NR	NR	NR	NR	R
8.1.3	Area EPS with automatic reclosing	R	NR	R	R	R	NR	NR	NR	NR	NR	NR	NR	R
8.2.2	Scheduled intentional islands	R	NR	R	R	R	NR	NR	NR	NR	NR	NR	NR	R
8.2.3	Unscheduled intentional islands	R	NR	R	R	R	NR	NR	NR	NR	NR	NR	NR	R
8.2.4	Conditions for unscheduled transition to intentional island	R	NR	R	R	R	NR	NR	NR	NR	NR	NR	NR	R
8.2.5	Transition of an intentional island from the area EPS	R	NR	R	R	R	NR	NR	NR	NR	NR	NR	NR	R
8.2.6	Reconnection of an intentional island to the area EPS	R	NR	R	R	R	NR	NR	NR	NR	NR	NR	NR	R
8.2.7	Adjustments to DER settings	R	NR	R	R	R	R	NR	NR	NR	NR	NR	NR	R
8.2.8	DER categories for microgrid islands	R	NR	R	R	R	NR	NR	NR	NR	NR	NR	NR	R
9.2	Distribution secondary grid networks	NR	NR	R	R	R	NR	NR	D	NR	NR	NR	NR	NR

Table continues

Subclause in IEEE Std 1547-2018		Subclause in IEEE Std 1547.1												
Subclause number	Title	DE1 – Confirm pertinent type test and operating conditions met	DE2 – Confirm system information and fault current review	DE3 – Confirm with protection and impact study	DE4 – System design review	IE1 – Verify installation matches design evaluation	IE2 – Verify information exchange and input applicable settings	IE3 – Verify state of system	CT1 – On-off test	CT2 – Reactive power capability and control verification	CT3 – Voltage and frequency tests	CT4 – Power quality tests	CT5 – Interoperability tests	CT6 – Islanding test
		8.5.1.1	8.5.1.2	8.5.1.3	8.5.1.4	8.5.2.1	8.5.2.2	8.5.2.3	8.5.3.1	8.5.3.2	8.5.3.3	8.5.3.4	8.5.3.5	8.5.3.6
9.3	Distribution secondary spot networks	NR	NR	R	R	R	NR	NR	D	NR	NR	NR	NR	NR
10.1	Interoperability requirements	R	NR	NR	R	R	R	NR	NR	NR	NR	NR	D	NR
10.2	Monitoring, control, and information exchange requirements	R	NR	NR	R	R	R	NR	NR	NR	NR	NR	D	NR
10.3	Nameplate information	R	NR	NR	R	R	R	NR	NR	NR	NR	NR	D	NR
10.4	Configuration information	R	NR	NR	R	R	R	NR	NR	NR	NR	NR	D	NR
10.5	Monitoring information	R	NR	NR	R	R	R	NR	NR	NR	NR	NR	D	NR
10.6.2	Constant power factor mode parameters	R	NR	NR	R	R	R	NR	NR	NR	NR	NR	D	NR
10.6.3	Voltage-reactive power mode parameters	R	NR	NR	R	R	R	NR	NR	NR	NR	NR	D	NR
10.6.4	Active power–reactive power mode parameters	R	NR	NR	R	R	R	NR	NR	NR	NR	NR	D	NR
10.6.5	Constant reactive power mode parameters	R	NR	NR	R	R	R	NR	NR	NR	NR	NR	D	NR
10.6.6	Voltage–active power mode parameters	R	NR	NR	R	R	R	NR	NR	NR	NR	NR	D	NR
10.6.7	Voltage trip and momentary cessation parameters	R	NR	NR	R	R	R	NR	NR	NR	NR	NR	D	NR
10.6.8	Frequency trip parameters	R	NR	NR	R	R	R	NR	NR	NR	NR	NR	D	NR
10.6.9	Frequency droop parameters	R	NR	NR	R	R	R	NR	NR	NR	NR	NR	D	NR
10.6.10	Enter service	R	NR	NR	R	R	R	NR	NR	NR	NR	NR	D	NR
10.6.11	Cease-to-energize and trip	R	NR	NR	R	R	R	NR	NR	NR	NR	NR	D	NR
10.6.12	Limit maximum active power	R	NR	NR	R	R	R	NR	NR	NR	NR	NR	D	NR
10.7	Communication protocol requirements	R	NR	NR	R	R	NR	NR	NR	NR	NR	NR	D	NR
10.8	Communication performance requirements	R	NR	NR	R	R	NR	NR	NR	NR	NR	NR	D	NR

Legend: R = required evaluation or test, D = test dependent on design evaluation, NR = no requirement, Shaded = no requirement in IEEE Std 1547-2018.

³IEEE Std 1547-2018 identifies this test as not required (NR). It is recommended to consider this commissioning test depending on design evaluation.

8.5.1 Detailed DER *design evaluation* for PCC composite

The detailed DER *design evaluation* is conducted during the design of the system, generally after the equipment selection has been finalized. During this evaluation, consideration is also given to *area EPS operator* interconnection practices, regulatory requirements, and local codes. As the outcome of the *design evaluation*, the compliance to the IEEE 1547 requirements is determined. Additionally, this step determines if any additional *installation evaluation* and/or *commissioning tests* are needed to verify compliance to IEEE Std 1547.

NOTE—It is recommended that this step occur early in a project so that the commissioning requirements can be included in the project plan.

8.5.1.1 *Design evaluation* DE1: Confirm pertinent *type test* and operating conditions are met

8.5.1.1.1 Purpose

The purpose of *design evaluation* DE1 is to confirm that the *type tests* and *production test* requirements are met by the *DER composite* system. Confirmation of these requirements shall be done by reviewing project documentation, certification, pertinent regulatory requirements, and other pertinent documentation.

Where supplemental devices are used to meet requirements, the *DER unit type tests* do not fully determine the *DER composite* capability to meet the IEEE 1547 requirements. This *design evaluation* determines for those requirements and other affected parameters whether the requirements are met. This may be done by engineering judgment but may also require *installation evaluation* and/or *commissioning tests*.

8.5.1.1.2 Requirements

This evaluation shall be performed when the equipment performing the IEEE 1547 functions has been selected for the *DER composite* design. The type-test results summary document for the DER equipment issued by the *testing agency* shall be used for the equipment evaluation. DER equipment datasheet shall be used to determine compliance to system operating conditions.

8.5.1.1.3 Procedure

The procedure is as follows:

- a) Review pertinent IEEE 1547 *type test* and certification details, and nameplate information of DER equipment. Verify compliance against owner's project requirements (OPR), project specifications, and regulatory requirements.
- b) Verify that the operating conditions including, but not limited to, the altitude, operating, and storage temperatures of the application are within the specification of the DER equipment.

8.5.1.1.4 Criteria

The evaluation shall verify the equipment selected has completed and passed the *type tests* for the requirements of the system. The results of this evaluation may identify a review of the system design as whole in meeting the IEEE 1547 requirements and may require further verification by performing *commissioning tests*.

The evaluation shall also verify that the DER operating conditions are within the specification of the equipment.

8.5.1.2 Design evaluation DE2: DER system information and fault current review

8.5.1.2.1 Purpose

The purpose of this evaluation is to provide the *area EPS operator* with information that may be used to evaluate impact of *DER composite* connection onto the *area EPS*.

8.5.1.2.2 Requirements

This evaluation shall be performed during interconnection application process and once the equipment performing the IEEE 1547 functions has been selected.

8.5.1.2.3 Procedure

The interconnection application submitted to the *area EPS operator* shall provide information to evaluate the impact of the *DER composite* on the *area EPS*. This information may include, but is not necessarily limited to, the following:

- a) Electrical model of DER equipment in a form as required by *area EPS operator*. Where generally accepted generic models for the DER type exist, providing model parameters rather than actual models may be acceptable.
- b) Electrical one-line diagram describing specification and characteristic of the electrical and DER equipment used in the *DER composite*.
- c) Fault current contribution from DER equipment used in the *DER composite*.
 - 1) For rotating machine technologies, this is typically in the form of impedance characteristic of the generator. See 5.18.2.1, 5.18.2.2, and 5.18.2.3 for reference.
 - 2) For inverter technologies, this is in the form of oscillographic representation of the fault currents and voltages. See 5.18.1 for reference.

The area EPC operator may require a *DER composite* model which incorporates all of the information listed above.

8.5.1.2.4 Criteria

The *DER composite* shall be considered in compliance if the model and fault current information has successfully been submitted for study and results are determined acceptable by the *area EPS operator*. Any non-compliance shall be identified and will necessitate corrective action.

8.5.1.3 Design evaluation DE3: Confirm with protection and impact study

8.5.1.3.1 Purpose

If a protection or impact study is required, the purpose of this evaluation is to perform the protection and impact study to confirm and coordinate the DER protection and control settings.

8.5.1.3.2 Requirements

This evaluation shall be performed once the equipment fulfilling the IEEE 1547 requirements have been selected and the *DER composite* has been fully designed, including specification of all equipment, controls, protections, communications and interconnecting components. *DER composite* protection settings shall be coordinated once results from the protection and impact study are available.

8.5.1.3.3 Procedure

The procedure is as follows:

- a) Confirm that the *DER composite* interconnects according to integration with *area EPS* grounding requirement in 4.12 in IEEE Std 1547-2018. Refer to IEEE Std C62.92.1 for definitions of grounding and IEEE Std C62.92.6 for guidance in the case of inverter DER.¹⁴¹
- b) Confirm that *area EPS* reclosing coordination meets requirements in 6.3 in IEEE Std 1547-2018.
- c) Using the results of the protection study, coordinate the voltage and frequency protection settings between the DER switchgear, recloser, and DER equipment, including, but not limited to, mandatory voltage trip settings, and mandatory frequency trip settings.
- d) Confirm that the fault current contribution from the *DER composite* does not adversely affect the function and operation of the protection equipment in the surrounding circuits.
- e) If the DER is connected to a secondary or spot network, confirm that the DER is implemented as required in Clause 9 of IEEE Std 1547-2018 and will not cause misoperation of any network protector(s) or exceed any network protector rating.

8.5.1.3.4 Criteria

The *DER composite* shall be considered in compliance if its voltage and frequency protection settings match the resulting settings from the protection and impact studies. Any mismatch necessitates settings adjustment during DER installation.

8.5.1.4 Design evaluation DE4: System design review

8.5.1.4.1 Purpose

The purpose of this evaluation is to review the *DER composite* system for compliance to the IEEE 1547 requirements. Confirmation of compliance shall be done by reviewing project design documentation.

The *DER composite* system may consist of multiple type tested DER equipment and supplemental devices that are designed to operate together to supply power generation to the *area EPS* and meet the IEEE 1547 requirements.

8.5.1.4.2 Requirements

This evaluation shall be performed when the *DER composite* design is mostly complete and major DER equipment has been sized and selected.

¹⁴¹Additional consideration may be given to cases that may have not been considered in IEEE Std C62.92.6.

8.5.1.4.3 Procedure

The procedure is as follows:

- a) Confirm that the *DER composite* provides the means to measure, or otherwise determine, voltage and other parameters as necessary, and delivers compliance with all IEEE 1547 requirements at the PCC.
- b) Confirm the following operating modes and settings requirements from *area EPS operator*¹⁴² and review that the *DER composite* is capable of providing the required performance.
 - 1) Enter service criteria: Enter service voltage and frequency settings, minimum intentional delay and rate-of-change of the active power.
 - 2) Voltage and reactive/active power control.
 - 3) Mandatory voltage and frequency tripping setpoints.
 - 4) Voltage regulation and ride-through performance categories.
 - 5) Dynamic voltage support.
 - 6) Frequency-droop control parameters.
 - 7) Inertial response, if required by *area EPS operator*.
 - 8) Islanding.¹⁴³
 - Verify that the design implements the unintentional islanding required by the *area EPS operator*.¹⁴⁴
 - If intentional islanding is required, confirm if *DER composite* shall apply different control and protection settings.
 - If *area EPS operator* does not specify operating mode, *DER composite* shall be set to default mode.
- c) Confirm that the *DER composite* and equipment could not energize the *area EPS* when it is de-energized.
- d) Review grounding scheme of *DER composite* and confirm that it is in coordination with the ground fault protection of the *area EPS*.
- e) Review design of the *DER composite* in meeting the reactive power capability requirement.¹⁴⁵ The *DER composite* may achieve the reactive power capability requirement with supplemental equipment such as, but not limited to, power factor correction capacitor bank. Consider the reactive power gains and losses within the *local EPS*, including cables, transformers, capacitors and reactors, as well as voltage levels within the *local EPS* over the range of active and reactive power outputs and PCC voltage, and the resulting limitations of reactive power created by such voltage levels.
- f) Review how the following functions/requirements of the *DER composite* are implemented in order to achieve compliance at the PCC.
 - 1) Response to external input: Disabling of permit service setting, limiting active power, change in mode and parameters.
 - 2) Prioritization of operating modes.

¹⁴²Such document may be called Utility Requirement Document by certain *area EPS operators*.

¹⁴³Additional DER integration issues may need to be evaluated for all *island* detection methods, including interactions of combinations of islanding detection methods on the same *area EPS*.

¹⁴⁴Some unintentional islanding methods that were type tested may only provide partial compliance and when installed, may require specific implementation of field devices. In this scenario, the conformance to the unintentional islanding requirement must be evaluated and may require a *commissioning test*.

¹⁴⁵Under specific conditions as specified in subclause 4.2 of IEEE Std 1547-2018, the reactive power capability requirements in subclause 5.2 of IEEE Std 1547-2018 may be evaluated excluding the influence of the *local EPS* load.

- 3) Enter service criteria: Enter service voltage and frequency settings, minimum intentional delay and rate-of-change of the active power.
- 4) Review that the *DER composite* meets the requirements of 4.10 in IEEE Std 1547-2018 even though the subsystems making up the *DER composite* may perform these functions separately.¹⁴⁶
- 5) Voltage and reactive/active power control.
- 6) Abnormal voltage: mandatory voltage tripping, voltage ride-through, dynamic voltage support, restore output after abnormal voltage condition.
- 7) Abnormal frequency: mandatory frequency tripping, frequency ride-through, ROCOF ride-through, voltage phase angle changes ride-through, frequency-droop operation.
- 8) Islanding.
 - Verify that the *DER composite* design provides compliance with unintentional islanding requirement.¹⁴⁷
 - For scheduled intentional islanding, review how request or command is sent by the DER or *area EPS operator*.
 - If *DER composite* is required to apply different control and protection settings, verify change in settings once in islanding mode.

If the function/requirement is performed by the system controller and this controller is type tested and approved for this function and the DER equipment are type tested and approved for this function, evaluate how the settings are aggregated to the DER equipment. Verify that the communication and input/output between the *plant controller* and DER as well as settings on this equipment are coordinated. This review with the certification of these equipment would suffice.

If the function/requirement is performed by the *plant controller* and this controller is not type tested or approved for this function however the DER equipment is type tested and approved for this function, further evaluation is required. This may include a review of the system controls, state sequencing diagram and/or bench test, or other methods.

If the function/requirement is performed by DER equipment that is not type tested or approved for this function, a detailed evaluation is required. This may include performing the *type test* on the *DER composite* system as outlined in this standard.

- g) When required by the *area EPS operator* and by performing a system impact study, evaluate the *DER composite* for impact on power quality of the *area EPS* to which it is connected.¹⁴⁸ This *design evaluation* may indicate risk of exceeding the required limits. In this case, *commissioning test* may be needed.
 - 1) Evaluate equipment and/or operation that may cause RVC such as energization of transformers, switching of capacitor banks for reactive power support, or abrupt change in power output.¹⁴⁹

To measure voltage for RVC at the PCC, use appropriate measurement devices that are capable of capturing rms voltage on one cycle basis.

¹⁴⁶For example, the DER equipment may perform the enter service voltage and frequency criteria function, however the system controller may perform the delay and active power rate-of-change functions, and various DER sources such as solar inverters, synchronous generators and/or energy storage may use different delay and active power generation setpoints.

¹⁴⁷Some unintentional islanding methods that were type tested may only be partially compliant and when installed and may require specific implementation of field devices. In this scenario, the end-to-end implementation of the unintentional islanding method should be evaluated and may require commissioning testing.

¹⁴⁸Under specific conditions as specified in subclause 4.2 of IEEE Std 1547-2018, the power quality requirements in Clause 7 of IEEE Std 1547-2018 may be evaluated excluding the influence of the *local EPS* load.

¹⁴⁹Sequencing of equipment operation such as energization of transformers, controlled ramp-up of output power and smaller step changes of switched capacitor banks may aid in reducing the magnitude of RVC.

The RVC limits shall not apply to infrequent events such as switching, unplanned tripping, or transformer energization related to commissioning, fault restoration, or maintenance; however, operation of these events may be performed to understand the impact on the *area EPS*.

- 2) Evaluate flicker results from DER equipment *type test* and any loads in the *DER composite* that may cause flicker. Using the DER equipment *type test* results, summation law in IEC/TR61000-3-7 may be used to evaluate the potential flicker cause by the DER. Alternatively, IEC 61400-21 defines flicker coefficient for certain types of power generation devices and provides methods to predict for potential flicker based on the grid characteristics at the PCC.

- 3) Identify equipment that may potentially be harmonic sources and/or loads and evaluate current distortion results from DER equipment *type test*. Individual harmonic source contributions may be combined using the harmonic summation laws in IEC 61000-3-6. Consider the impact of shunt and series harmonic impedances within the *local EPS*, including capacitors, transformers, and cables, which may attenuate harmonics or may form resonances with the *area EPS* harmonic impedance to amplify harmonic currents.

DER that meet current distortion limits when connected to an undistorted external system, such as during type testing, may exceed current distortion limits when connected to a field environment having voltage distortion. IEEE 1547 limitations on harmonic current distortion specifically exclude harmonic currents due to *area EPS* voltage distortion not caused by the DER. Such ambient distortion is invariably present, thus making difficult or impossible the task of evaluating distortion compliance in the field.

Design evaluation may indicate risk of exceeding the current distortion requirement and in this case, the current distortion of the *DER composite* shall be measured during commissioning of the DER. If the DER current distortion exceeds the limits allowed in IEEE Std 1547, the DER owner shall determine the appropriate resolution.

- 4) If the GFOV and LROV tests were performed on the *DER unit*, the results obtained from that *type tests* can be used to evaluate the effect of the DER on the *area EPS* overvoltage limits as defined in 7.4.1 of IEEE Std 1547.¹⁵⁰
 - h) Verify that the *DER composite* with system controller can communicate with *area EPS* with one of the protocols listed in 10.7 of IEEE Std 1547-2018 and capable to meet the communication performance requirements in 10.8 of IEEE Std 1547-2018.
 - i) If connected to a grid or spot secondary distribution network, confirm that the control and protection of the *DER composite* properly coordinates with the settings and status of network protectors in the *area EPS*.

8.5.1.4.4 Criteria

The *DER composite* shall be considered in compliance if it has been evaluated and confirmed meeting the requirements of IEEE Std 1547. Identify any gap that shall be evaluated during DER installation and commissioning.

8.5.2 Detailed DER *installation evaluation* for PCC composite

The detailed DER *installation evaluation* is performed on-site after equipment is delivered and put in place. This is an evaluation prior to or at the time of commissioning to verify that the *DER composite* as delivered and installed meets the interconnection and interoperability requirements of IEEE Std 1547, as well as the local regulatory and EPS operator requirements. The primary inputs to this are the *design evaluation*

¹⁵⁰The results of the tests may inform the system design of the need for supplemental grounding sources in certain applications.

documentation and a physical inspection of the system, as installed. In addition, for partially compliant systems certification of additional devices within the system may be required.

Results of this evaluation shall be documented, highlighting acceptance or failure and any corrective actions needed. This evaluation may result in the need for further actions prior to *commissioning tests*.

8.5.2.1 Installation evaluation IE1: Verify installation matches design evaluation

8.5.2.1.1 Purpose

The purpose of this evaluation is to confirm that the *design evaluation* is being verified with the actual *DER composite* installed.

The evaluation shall determine whether the DER complies with the pertinent IEEE 1547 requirements identified in this subclause by verifying that the specified equipment with correct parameters and configurations has been installed.

In addition, any corrective actions identified in the DER *design evaluation* shall be verified as complete.

Confirmation of these requirements shall be done by reviewing the results of the *design evaluation* and inspecting the *DER composite* as installed to verify the installation and configuration matches that of project documentation and the design review.

This evaluation should confirm continuity of the end-to-end physical wiring from the DER *plant controller* to the measurement devices and DER equipment providing the IEEE 1547 functions. The *DER composite* may be comprised of *plant controller* that controls multiple DER equipment and receives measurement from devices that measure various parameters such as voltage, current, active and reactive powers. These devices may be designed together to fulfill the requirements of IEEE Std 1547-2018.

The procedures included in this subclause also verifies correct application of external inputs to the *DER composite* such as the permit service setting and active power limit, which may be received by the DER via communication interface or hardwire digital or analog signals.

8.5.2.1.2 Requirements

This *installation evaluation* shall be performed when the major DER equipment has been installed and prior to commissioning. Alternatively, this *installation evaluation* may be performed on an on-going basis throughout completion of project installation.

Some of the procedures may require availability of the DER control power to access the DER plant and/or unit controller board and interface.

8.5.2.1.3 Procedure

The procedure is as follows:

- a) Review the results of the DER *design evaluation* and project documentation for information specifically related to *DER composite* project-specific settings and configurations.
- b) Confirm that equipment on site is that used in the basic DER *design evaluation* and matches project documentation. This is done by confirming that nameplate data of installed equipment

matches that identified in the *design evaluation* and project documentation. Nameplate data includes model number, serial number, configuration information, and other parameters.

- c) Verify that the DER installed is connected to the correct PCC per design.
- d) Verify installation of grounding scheme and wiring per DER design.
- e) If required by the *area EPS operator*, verify isolation device between the *DER composite* and *area EPS* and implementation for accessible, lockable and visible break device and is clearly marked accordingly.
- f) Confirm availability of a local DER communication interface and that the following list of information exchange is available from the DER: nameplate, configuration, monitoring, and management information.

8.5.2.1.4 Criteria

Confirmation of these requirements shall be done by reviewing the results of the *design evaluation* and inspecting the *DER composite* as installed to verify the installation and configuration matches that of the project documentation and the design review.

The *DER composite* shall be considered in compliance if the DER installed matches system as designed and evaluated in the *design evaluation*.

Any non-compliance shall be corrected.

Failure of the documentation and inspection to demonstrate that the installation matches the *design evaluation* may result in corrective actions needing completion before commissioning of the DER.

8.5.2.2 Installation evaluation IE2: Verify information exchange and input applicable settings

8.5.2.2.1 Purpose

The purpose of this evaluation is to confirm the availability of information of the *DER composite* via the local DER communication interface and that the IEEE 1547 pertinent system settings are applied per the requirements listed below and project documentation. Confirmation of this shall be done by reviewing the actual settings in the installed equipment and verifying them against the settings provided in project documentation.

In addition, this subclause verifies and documents the DER equipment software and firmware revisions or any need for upgrade from the default revision.

The procedures below require availability of the DER control power to access the DER plant and/or unit controller board and interface.

8.5.2.2.2 Requirements

This *installation evaluation* shall be performed when the DER installation is nearing completion and the control system of the pertinent DER equipment can be energized.

8.5.2.2.3 Procedure

The procedure is as follows:

- a) Review the results of the *design evaluation* and project documentation for information specifically related to *DER composite's* project-specific settings.
- b) Verify that the parameters listed in 10.3 through 10.6 of IEEE Std 1547-2018 are available and read-capable or write-capable via the local DER communication interface at the PCC according to requirements stated.
- c) The following settings shall be confirmed with the *area EPS operator* and shall be adjusted in the DER devices or the DER *plant controller* accordingly. If not specified by *area EPS operator*, default values as specified in IEEE Std 1547 shall be used.
 - 1) Enter service parameters:
 - i) Enter service adjustable time delay
 - ii) Enter service adjustable time period
 - iii) Enter service maximum active power increase of any single step
 - 2) Voltage and reactive power control mode:
 - i) Either constant power factor mode, voltage-reactive power mode, active power-reactive power mode or constant reactive power mode. If not specified by *area EPS operator*, default mode is constant power factor mode.
 - ii) If constant power factor mode is selected, apply the power factor setting.
 - iii) If voltage-reactive power mode is selected, apply the voltage-reactive power parameters per Table 8 of IEEE Std 1547-2018.
 - iv) If active power-reactive power mode, apply the active power-reactive power parameters per Table 9 of IEEE Std 1547-2018.
 - v) If constant reactive power mode is selected, apply the reactive power setting.
 - 3) Voltage and active power control mode:
 - i) Enable voltage-active power mode if specified by *area EPS operator*. If not specified, default mode is disabled.
 - ii) If voltage-active power mode is selected, apply the voltage-active power parameters per Table 10 of IEEE Std 1547-2018.
 - 4) Response to *area EPS* abnormal voltages
 - i) Ride through performance category.
 - ii) Voltage trip and *clearing time* settings for Category I, II, or III, accordingly.
 - 5) Response to *area EPS* abnormal frequencies
 - i) Ride through performance category.
 - ii) Frequency trip and *clearing time* settings for Category I, II, or III, accordingly.
 - iii) Frequency-droop parameters per Table 24 of IEEE Std 1547-2018.
- d) Verify that these parameters can be adjusted locally and/or remotely as specified by the *area EPS operator*. If remotely, verify that the remote controller or remote access can provide the settings and that the DER equipment received the settings. This verifies the continuity of the end-to-end communication wiring.
- e) Once completed, settings adjustments shall be recorded and provided to *area EPS operator* for confirmation and reference.
- f) If interconnected to a distribution secondary grid network, coordinate DER protection settings with the network protector relay function, and confirm with *area EPS operator*.
- g) Verify the DER equipment software and firmware revision and confirm with the DER equipment manufacturer of the revisions that meet the IEEE 1547 requirements.
- h) If any upgrade is required, verify that correct parameters and settings are applied to the upgraded software and firmware revision. It is advisable that the *DER operator* is aware and

understands the changes of the software or firmware revisions to evaluate the impact of the changes to the DER operation. This can be accomplished by means including, but not limited to, requesting the design change documentation, integration with DER, evaluating impact, and performing bench test of the DER controls and operation.

8.5.2.2.4 Criteria

The *DER composite* shall be considered in compliance if application of settings as specified by *area EPS operator* has been completed. If not specified, default settings shall be applied. Any non-compliance shall be corrected. Once completed, settings adjustments shall be recorded and provided to *area EPS operator* for confirmation and reference.

The *DER composite* shall be considered in compliance if it contains the software and firmware revision that meets the IEEE 1547 requirements. If any software and/or firmware upgrade is required, performance of the *DER composite* after the upgrade still meets the IEEE 1547 requirements.

8.5.2.3 Installation evaluation IE3: Verify state of system

8.5.2.3.1 Purpose

The purpose of this evaluation is to verify state of *DER composite* when the system is energized with control power and prior to system start-up.

8.5.2.3.2 Requirements

This *installation evaluation* shall be performed when the DER installation is completed and the control system of the pertinent DER equipment can be energized.

8.5.2.3.3 Procedure

The procedure is as follows:

- a) With the *DER composite* deenergized and control power to DER available, command the *DER composite* to start-up. *DER composite* can be in the deenergized state if the main system switchgear is in open position and *DER composite* is not connected to the *area EPS*. If the *DER composite* consists of similar make and model of DER equipment, one test on one DER equipment may be used to represent behavior of all DER equipment in the system, with the condition that DER equipment parameters and setting are similar in all of the DER equipment. If the *DER composite* consists of multiple make and model of DER equipment, or DER equipment do not contain similar parameters and settings, this test shall be performed once on the group of DER with similar make and model or settings.
- b) In the distribution secondary spot network, verify that the *area EPS* network bus is energized by more than 50% of the installed network protector prior to permitting the connection of the DER to the *area EPS*.

8.5.2.3.4 Criteria

The *DER composite* shall be considered in compliance if the DER does not proceed to start and energize the *area EPS* when *area EPS* is not energized.

For a *DER composite* installed in a secondary network, it shall also be considered in compliance if the connection of the DER to *area EPS* is only permitted if *area EPS* network is already energized by more than 50% of the installed network protector.

8.5.3 Detailed *commissioning tests* for PCC composite

The *DER composite commissioning tests* are conducted after installation of the system has been completed, all de-energized checks have been passed and system has been approved for energization. In addition to the tests outlined in this subclause, any tests determined from the design and *installation evaluations* shall be performed as part of the *commissioning test* to verify compliance. Once the *DER composite* has completed the commissioning activities and prior to continuous operation, as-built DER configuration and commissioning results shall be documented and submitted to the *area EPS operator*.

8.5.3.1 Commissioning Test CT1: On-off test

8.5.3.1.1 Purpose

The purpose of this test is to evaluate the impact of DER energization and operation on the *area EPS*. The *DER composite* shall be brought online, operated up to the maximum available capacity,¹⁵¹ and go through planned and unplanned shutdown sequences.

8.5.3.1.2 Requirements

This test shall be performed when the *DER composite* has passed deenergized and pre-energization checkouts and has been approved for energization and operation at the specified operating modes. The *area EPS operator* may require representation during initial energization and during the testing of the DER.

8.5.3.1.3 Procedure

The description outlined in this subclause are recommended actions. Tests shall be performed as required by, and to the satisfaction of, the *area EPS operator*. Detailed test procedures shall be developed in coordination with the DER designer and equipment manufacturer.

- a) When the *area EPS* is de-energized, observe that the DER does not energize the *area EPS*.
- b) With the *DER composite* in the OFF state, bring the DER online. The *DER composite* shall be set to the specified operating mode, active, reactive power or power factor setpoints. Confirm that the *DER composite* starts to come online (delivering power into *area EPS*) or makes connection to the *area EPS* when the DER voltage and frequency are within range specified in Table 4 or Table 5 of IEEE Std 1547-2018 and permit service is enabled. During the start-up of the *DER composite*, observe the *area EPS* voltage response (transient and steady-state), any intentional delay and power ramping until the *DER composite* reaches a steady-state operation. Simulate a disconnect and reconnect condition and observe the return to service of the DER. This may be achieved by means including, but not limited to, manually triggering a disconnect of the *DER composite* from the *area EPS* using a device other than the interconnection device that provides the cease-to-energize function or creating a temporary abnormal condition by adjusting the voltage trip settings to cause a disconnect. Once the *DER*

¹⁵¹For installations that are dependent on input source availability such as solar and wind installations, the *DER system* needs to be operated up to the available capacity at the time of test or as agreed with the *area EPS operator*.

- composite* is disconnected, this parameter is reversed to allow for reconnect or return to service.
- c) In the event that the *DER composite* cannot be reasonably verified by the *design evaluation* phase to limit the active and reactive power export to the *area EPS* per the requirements of subclause 4.5 in IEEE Std 1547-2018 during the cease to energize state, the *DER composite* shall be tested. Active and reactive power export shall be measured. The measurement shall be taken at the *point of common coupling* to the *area EPS*. The *DER composite* shall be operated at full power and nominal voltage condition and a cease to energize condition shall be initiated.
 - d) Perform end-to-end verification of the wiring from the measurement devices to the associated controller(s) and from the associated controller to the DER equipment and interconnection devices that serve the function of meeting the IEEE 1547 requirements. Verification is achieved by referencing the DER design documentation and performing specific procedure from the DER designer and equipment manufacturer, which may include the following:
 - 1) Energizing measurement bus with appropriate voltage and current, then confirming reading at the controller and within the acceptable accuracy range.
 - e) Perform end-to-end verification of the external input wiring to the *DER composite*. Verification is done by referencing the *DER composite* design documentation and performing specific procedure from the DER designer, which may include the following:
 - 1) Energizing or providing appropriate commands or signals at the external input connection point, then confirming reading at the DER *plant controller* and aggregation of commands or signals to the DER equipment. With the *DER composite* operating and generating power, it shall be verified for response to external inputs including permit service, active power limit and operating modes. These inputs shall be provided at the external input connection point and DER response shall meet the performance and response time requirements of 4.6 in IEEE Std 1547-2018.
 - f) Perform any other tests determined to be necessary by the *DER composite* and *area EPS operator* as the outcome from the *design evaluation*.

8.5.3.1.4 Criteria

Observe the *area EPS* response and *DER composite* stability. Review observation with *area EPS operator* and perform any adjustment to operating parameters/setpoints in coordination with *area EPS operator* as necessary.

The *DER composite* shall be considered in compliance if the associated DER *plant controller* is measuring the system parameters (voltages, current, frequency, real and reactive power) within acceptable accuracy and isolation devices disconnect *DER composite* from the *area EPS* when commanded by the associated DER *plant controller*.

8.5.3.2 Commissioning Test CT2: Reactive power capability and control verification

8.5.3.2.1 Purpose

The purpose of this test is to verify the reactive power capability and control of the *DER composite*. The *DER composite* may consist of multiple active and reactive power sources. If the device performing the reactive power controls is not type tested, the control requirement shall be verified, and the method of

verification may be determined with agreement between the *DER operator* and *area EPS operator*. The operation of the *DER composite* and impact to the *area EPS* shall be observed.

8.5.3.2.2 Requirements

DER composite may consist of multiple reactive and active power sources. This test shall be performed when each of the sources have passed deenergized and pre-energization checkouts and has been approved for energization and operation.

Under specific conditions as specified in 4.2 of IEEE Std 1547-2018, the reactive power capability requirements in 5.2 of IEEE Std 1547-2018 may be evaluated excluding the influence of the *local EPS* load.

8.5.3.2.3 Procedure

The description outlined in this subclause are recommended actions. Tests shall be performed as required and agreed with the *area EPS operator*. Detail test procedures shall be developed in coordination with the DER designer and equipment manufacturer.

- a) Perform a verification of the reactive power capability from 0 var to full rated var or the maximum var as agreed with the *area EPS operator*, exercising all sources of reactive power designed in the *DER composite*.¹⁵² The selective var setpoints to be verified shall be agreed with the *area EPS operator*. Observe the *area EPS* response (transient and steady-state) to the reactive power sweep, verifying smooth and continuous variations in the net reactive power.
- b) Operate the *DER composite* in the reactive power mode selected and approved by the *area EPS operator*.
- c) If the constant power factor or constant reactive power modes is selected, verify that the mode selection, power factor and reactive power setpoints can be adjusted by the *area EPS operator*. Select several setpoints to be tested and agreed by the *area EPS operator*.
- d) If the voltage-reactive, active-reactive, or voltage-active power modes is selected, the operation of the control curve may need to be demonstrated as required by the *area EPS operator*. *Reference point of applicability* for this demonstration shall be at the PCC and shall include exercising of all reactive and active power sources. Selection of operating points of the curves shall be agreed by the *area EPS operator*, however recommendation includes the knee points of the curve and one point in each curve region. The procedure shall be designed and agreed by *DER operator* and *area EPS operator*.

8.5.3.2.4 Criteria

The *DER composite* shall be considered in compliance if it demonstrated that it meets the required reactive power requirements from the *area EPS operator*. Observe the *area EPS* response and DER stability. Review observation with *area EPS operator* and perform any adjustment to operating parameters/setpoints in coordination with *area EPS operator* as necessary.

¹⁵² In some cases, in order to supply the reactive power required, a *DER composite* system may include a capacitor bank to extend the range of variable reactive power sources. The capacitor bank control may introduce a step change in reactive power. The *DER composite* system may also include a power converter that could provide a smooth ramp of reactive power. The combination of DER and supplemental devices and the *DER composite* as a whole may supply smooth and continuous variations in the net reactive power.

8.5.3.3 Commissioning Test CT3: Voltage and frequency tests

8.5.3.3.1 Purpose

The purpose of this test is to verify the abnormal voltage and frequency response of the *DER composite*. The *DER composite* shall be in compliance with the response to *area EPS* abnormal conditions requirements and verification may consist of *commissioning test* as required by the *area EPS operator*. The impact of the DER response to the *area EPS* shall be observed.

8.5.3.3.2 Requirements

This test shall be performed when the *DER composite* has passed deenergized and pre-energization checkouts, has been approved for energization and operation at the specified operating modes and has achieved stable operation at the specified operating conditions. The *area EPS operator* may require representation during initial energization and during the testing of the DER.

8.5.3.3.3 Procedure

The need for *commissioning tests* for *DER composite* with RPA at the PCC is as displayed in [Table 75](#). The need for any *commissioning test* for PCC systems is determined in the *design evaluation*. Tests shall be performed as required by the *area EPS operator* with details determined by mutual agreement between the *DER operator* and EPS operator.

The DER response to *area EPS* abnormal voltage and frequency conditions are typically performed by the DER devices which are type tested and approved for these functions. Due to complication of performing abnormal voltage and frequency tests in the field, *design evaluation* and *installation evaluation* should have been performed prior to the commissioning phase for the purpose of evaluating conformance of the *DER composite* to the *area EPS* abnormal voltage and frequency requirements and settings coordination. *Signal injection test method* may be considered if the *DER composite* or devices have the provision for this method. Adjustment of the shall-trip settings may be made if verification of the mandatory trip function is required.

8.5.3.3.4 Criteria

The *DER composite* shall be considered in compliance if it demonstrated that it meets the required abnormal voltage and frequency response, magnitude and *clearing time* requirements. Verification of compliance to this requirement may be achieved by a combination of *design evaluation*, *installation evaluation*, and *commissioning test* as accepted by the *area EPS operator*. Observe the DER response. Review observation with *area EPS operator* and perform any adjustment to operating parameters/setpoints in coordination with *area EPS operator* as necessary.

8.5.3.4 Commissioning Test CT4: Power quality tests

8.5.3.4.1 Purpose

The purpose of this test is to verify that the impact of the DER operation to the *area EPS* power quality are within the specified limit. Any of the power quality tests in the field shall be conducted if any field operational and performance issues arise, determined required from the *design evaluation* and if required by the *area EPS operator*.

Test cases and procedures shall be agreed with *area EPS operator* and may include evaluation at various conditions including DER startup, disconnect and shutdown, full operating range of the *DER composite* as well as external conditions such as cloud coverage for solar plants and operation of other nearby facilities. The performance of the *DER composite* for power quality may be continuously observed by the *area EPS operator*.

8.5.3.4.2 Requirements

This test shall be performed when the *DER composite* has passed deenergized and pre-energization checkouts and has been approved for energization and operation at the specified operating modes. The *area EPS operator* may require representation during initial energization of DER.

Under specific conditions as specified in 4.2 of IEEE Std 1547-2018, the power quality requirements in Clause 7 of IEEE Std 1547-2018 may be evaluated excluding the influence of the *local EPS* load.

The measurement equipment used for power quality tests shall be compliant with IEC 61000-4-30 Class A.

8.5.3.4.3 Procedure

The description outlined in this subclause are recommended actions. Tests shall be performed if power quality issues arise or as required by and agreed with the *area EPS operator*. Detail test procedures shall be developed in coordination with the DER designer and equipment manufacturer.

- a) The power quality requirements shall be measured and met at the *point of common coupling* with the *area EPS*. Connect the measurement equipment at the PCC connection between the *DER composite* and the *area EPS*. The measurement equipment shall be capable of measuring ac, dc, rms, instantaneous, and harmonic content of the voltages, currents, and frequency. A flicker meter may be used to measure any flicker contribution.
- b) Once the setup of measurement devices is complete, perform measurement of the *DER composite* operated under the following conditions:
 - 1) During start-up of the *DER composite*, energize (close in) the step-up transformers. Observe impact on the energization in-rush current to the *area EPS*.¹⁵³
 - 2) Turn-on *DER composite* and sweep the active and reactive power from 0 to full power,¹⁵⁴ exercising (switch in and out) any sources of active and reactive power (such as capacitor banks). Observe impact to the *area EPS*.
 - 3) Perform a disconnect event that causes a step change in power delivery (not a soft shutdown, i.e., ramp down of power). Observe impact to the *area EPS*.¹⁵⁵
 - 4) Observe power quality of *area EPS* over a duration of time to capture nominal operating condition of the *DER composite*. The conditions may include, but are not limited to, cloud coverage for solar DER and operation of other generation and load sources connected to the *area EPS*.

¹⁵³RVC limits in IEEE Std 1547 do not apply for infrequent transformer energizations, or energizations related to maintenance, outage restoration, or commissioning.

¹⁵⁴For installations that are dependent on input source environmental variability such as solar, wind and renewable fuel installations, *DER composite* needs to be operated up to the available capacity at the time of test or as agreed with *area EPS operator*.

¹⁵⁵RVC limits in IEEE Std 1547 only apply to frequency and abrupt voltage variations that take place over a timespan of one second.

8.5.3.4.4 Criteria

The *DER composite* shall be considered in compliance if the impact of the DER operation to the *area EPS* power quality is within the specified limit. Review observation with *area EPS operator* and apply any mitigation action as necessary.

8.5.3.5 Commissioning Test CT5: Interoperability tests

8.5.3.5.1 Purpose

The purpose of this test is to verify functionality of interoperability functions of the *DER composite* with the EPS operator.

8.5.3.5.2 Requirements

This test shall be performed when the DER installation is nearing completion, the control system of the pertinent DER equipment can be energized, and the *area EPS operator* has deployed the means to communicate with the *DER composite*.

8.5.3.5.3 Procedure

The procedure is as follows:

- a) Verify the DER equipment software and firmware revision and confirm with the DER equipment manufacturer of the revisions that meet the IEEE 1547 requirements. If any upgrade is required, verify that correct parameters and settings are applied to the upgraded software and firmware revision. It is advisable that the *DER operator* is aware and understands the changes of the software or firmware revisions to evaluate the impact of the changes to the DER operation. This may be accomplished by means including, but not limited to, requesting the design change documentation, integration with DER, evaluating impact and performing bench test of the DER controls and operation.
- b) Verify that the EPS operator can access the settings confirmed in 8.5.2.2 (IE2 in Table 75).
- c) If the DER is equipped with a communications interface that supports one or more of the three allowable protocols in IEEE Std 1547-2018 perform the following test:
 - 1) Using the communications interface, send a command to read the DER nameplate information. Read the DER response.
 - 2) Compare the DER response to the nameplate information in the provided documentation
 - 3) Identify any inconsistencies and review with the equipment supplier.
 - 4) The test passes if the nameplate information is identical.

8.5.3.5.4 Criteria

The *DER composite* shall be considered in compliance if software and firmware revisions meet the function and performance requirements for the *area EPS operator* in IEEE Std 1547 and if the *area EPS operator* is able to access the settings as specified in Clause 10 of IEEE Std 1547-2018.

8.5.3.6 Commissioning Test CT6: Islanding test

8.5.3.6.1 Purpose

The purpose of this test is to verify the correct response of a *DER composite* to the islanding requirements in IEEE Std 1547.

8.5.3.6.2 Requirements

This test shall be performed when the *DER composite* has passed deenergized and pre-energization checkouts and has been approved for energization and operation at the specified operating modes. The *area EPS operator* may require representation during the islanding test.

8.5.3.6.3 Procedure

Determine the agreed-upon islanding operating mode and the implementation in the *DER composite* as evaluated in the *design evaluation*.

Based on this determination, either the unintentional islanding test procedure (8.5.3.6.3.1) or the intentional islanding test procedure (8.5.3.6.3.2) shall be followed. Any other requirement and specific alteration to the procedure shall be agreed upon between the *area EPS operator* and *DER operator*.

8.5.3.6.3.1 Unintentional islanding test procedure

If a reverse-power or minimum import power function is used as the method to detect unintentional islanding, it shall be tested by *signal injection test methods*, by adjusting the DER output and local loads, or by other suitable methods to verify that the function is met and that the DER ceases to energize the *area EPS*. Reverse-power or minimum import power *type test* procedure may be used as reference to design the test applicable for the field installed DER.

For a *DER composite* that uses direct transfer trip (DTT) method to comply with the unintentional islanding requirement, a DTT *signal injection test method* shall be used to verify compliance.

For the following means of *island* detection compliance, the procedure steps a) through f) shall apply:

- A DER that uses powerline conducted permissive signal method to comply with the unintentional islanding requirement. The disconnection point shall occur between the signal generation point and the signal detection point.
- A DER verified to have autonomous capabilities to detect unintentional islands in accordance with the tests specified in 5.10.2.
 - a) Verify that the DER is energized and connected to the *area EPS*.
 - b) Verify that the DER is configured with its applicable operating settings and is operating normally.
 - c) Create an islanding condition by disconnecting the DER from the *area EPS* using a device other than the interconnection device of the DER that provides the cease-to-energize function.
 - d) Measure the time from the creation of the *island* until the DER ceases to energize the *area EPS*.
 - e) The time should meet either the 2 s requirement or the conditional extended *clearing time* agreed between the *area EPS operator* and the *DER operator*.

- f) Remove the islanding condition and observe the DER re-energization to the *area EPS* meets the performance requirements in 6.3 of IEEE Std 1547-2018.

8.5.3.6.3.2 Intentional islanding test procedure

For *DER composite* intended to be operated as an *intentional island*, determine the capability of a *DER composite* to operate in an *intentional island* mode. There are two means by which an *intentional island* system can transition to an islanded condition—scheduled and unscheduled.

- a) Verify that the DER is energized and connected to the *area EPS*.
- b) Verify that the DER is configured with its applicable operating settings and is operating normally.
- c) Create an *island* condition.
 - 1) For a scheduled *intentional island*: Create the *island* by providing the islanding command (manual action or other dispatch means that trigger the transition).
 - 2) For an unscheduled *intentional island*: Create the *island* by creating an abnormal condition on the *area EPS*.
- d) Verify the DER transition from operation in parallel and synchronized with the *area EPS* to islanded mode. Observe the impact and stability of DER and *area EPS* operation during and after the transition.
- e) If applicable, certain DER may have to adjust several control and protection setting when operating in the intentional *area EPS island*. In this case, verify that these alternate settings and ranges were adjusted in the *intentional island* operating mode.
- f) Remove the islanding condition and observe that the DER reconnection to the *area EPS* occurs based on 8.2.6 of IEEE Std 1547-2018.

8.5.3.6.4 Criteria

The *DER composite* shall be considered in compliance if it passes all the applicable islanding tests, meets the time requirements within the specified limit, and meets the performance of the islanding transition based on Clause 8 of IEEE Std 1547-2018. Review observation with *area EPS operator* and apply any mitigation action as necessary.

9. Periodic interconnection tests

The purpose of periodic tests is to verify that the *DER unit* or system continues to meet the requirements of IEEE Std 1547. Subclause 11.2.6 of IEEE Std 1547-2018 shall apply. When reverification is required after the commissioning of the *DER unit* or system, [Clause 8](#) of this standard shall be referenced for in-field verification methods as agreed between the *area EPS operator* and *DER operator*.

Reverification of the impacted IEEE 1547 requirements may be required when any of the following occurs:

- Functional software or firmware changes have been made on the DER. The changes to the software or firmware has not been type-tested.
- Any hardware component of the DER has been modified in the field or has been replaced or repaired with parts that are not substitutive components compliant with IEEE Std 1547.
- Protection functions have been adjusted after the initial commissioning process.
- Operating modes or settings have been changed after the initial commissioning process.
- If any field operational and performance issues due to power quality arise, power quality tests per the appropriate [Clause 8](#) procedures shall be required if required by the *area EPS operator*.

When functional software or firmware changes are performed, the adjustable settings as specified in 10.6 (Management Information) of IEEE Std 1547-2018 shall be restored to the values prior to the changes to the DER.

In the event that any reverification or change in settings or configuration is required, the updated DER configuration and reverification results shall be documented and submitted to the *area EPS operator*.

Annex A

(normative)

Test signals

A.1 Introduction

The test signals in this annex are generic functions that can be used for ramp or step tests to determine a particular set point of a particular parameter under test (PUT). These test signals are used in several of the tests in [Clause 5](#) including undervoltage, overvoltage, underfrequency, overfrequency, and reverse or minimum import power tests. Note that the examples show positive ramp or step for high-magnitude parameter excursions. The ramp or step are negative for low-magnitude parameter excursions (e.g., undervoltage, underfrequency).

A.2 Illustration of *clearing time*

[Figure A.1](#) illustrates the terms and concepts described after the figure.

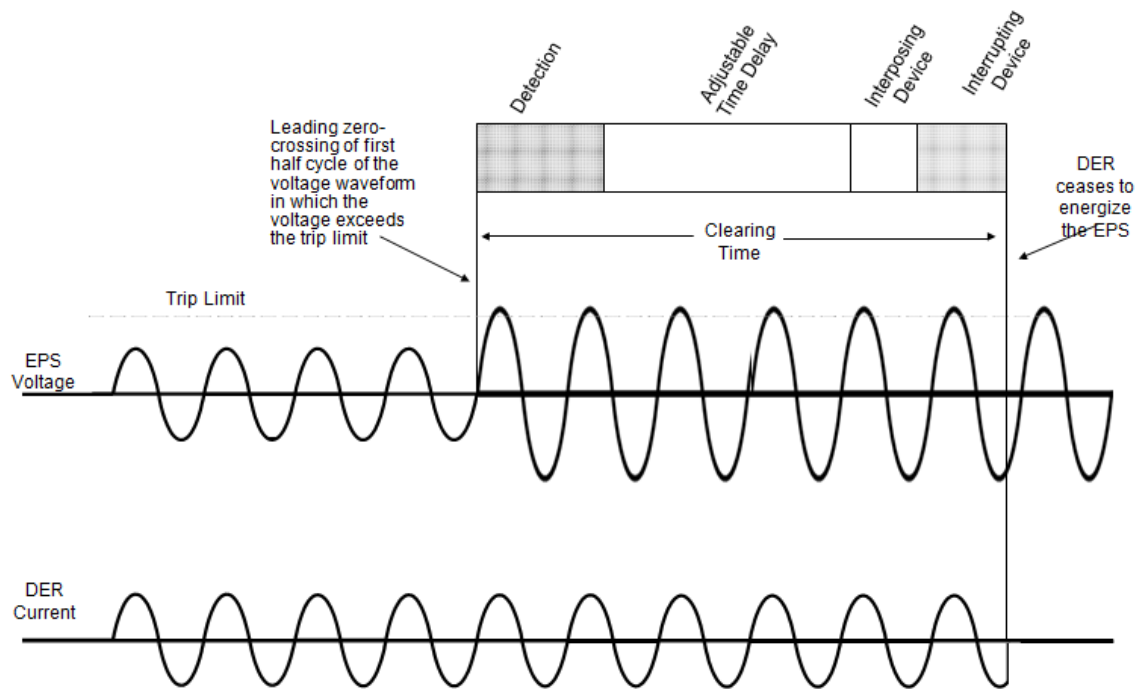

detection time: The minimum length of time from the inception of the abnormal condition to the change in state of the EUT's output dedicated to controlling the *interrupting device*. This is often on the order of 8 ms to 16 ms. *Syn:* processing time.

adjustable time delay: The intentional time added to the *detection time* in order to provide the desired *clearing time*. This may be adjustable from zero to several seconds.

interposing device time: The delay introduced in systems that include an auxiliary interface device, often an electromechanical hinged-armature relay. This is often on the order of 8 ms to 16 ms.

interrupting device time: Typically, the solenoid-initiated (trip) movement of the spring-loaded mechanism of the main current-carrying contacts of a circuit breaker plus any power arc interruption time (nonvacuum) that is dependent on the time to the next current zero-crossing. *Interrupting device* time varies widely from one half cycle to several cycles. For inverters, this would be the time needed to stop the bridge firing function and to cease energy outflow, which may be essentially zero time.

clearing time: The time between the start of an abnormal condition and the DER ceasing to energize the *area EPS*. It is the sum of the *detection time*, any adjustable time delay, the operating time plus arcing time for any interposing devices (if used), and the operating time plus arcing time for the *interrupting device* (used to interconnect the DER with the *area EPS*).

trip time: The interval that begins at the leading zero-crossing of the first half cycle of the voltage waveform in which the measured parameter (e.g., frequency, voltage, power) exceeds the trip limit and ends when the EUT responds as required. The trip time includes any time delay(s) used in conjunction with the EUT's protection functions. Depending on the EUT, the trip time may be a component of or equivalent to the *clearing time*. Normative requirements are based on *clearing times*.

Figure A.1—Illustrative example of detection and clearing time

A.3 Step change test signal—General

The test signal described in this subclause is used to characterize the accuracy of the *clearing time* setting for relevant protection parameters.

Vary the parameter under test (PUT) according to the magnitude step function defined herein. Only the PUT shall be varied. Therefore, all other parameters shall be held at nominal values. The time test signal shall take the form described in Equation (A.1).

$$p(t) = A \times u(t - t_b) + P_b \tag{A.1}$$

where

- p is the magnitude of the parameter under test (PUT). (V, f, P, Q , etc.)
- t is time (s)
- A is a scaling factor¹⁵⁶
- $u(t)$ is the unit step function¹⁵⁷
- P_b is the starting point of the step function (in units of the PUT)¹⁵⁸

When the step function conflicts with a design characteristic or settings of the EUT, an alternative method that is agreeable to the manufacturer and the *testing agency* may be used.

¹⁵⁶The scaling factor A needs to be chosen so that P_U is at least 110% (90% for under value tests) of P_T . *Exception:* For frequency tests, the scaling factor A needs to be chosen so that P_U is at least 101% (99% for under value tests) of P_T .

¹⁵⁷ $u = 0$ for $t < 0$ and $u = 1$ for $t \geq 0$.

¹⁵⁸The starting point P_b needs to be within 10% of, but not exceed, the trip point magnitude.

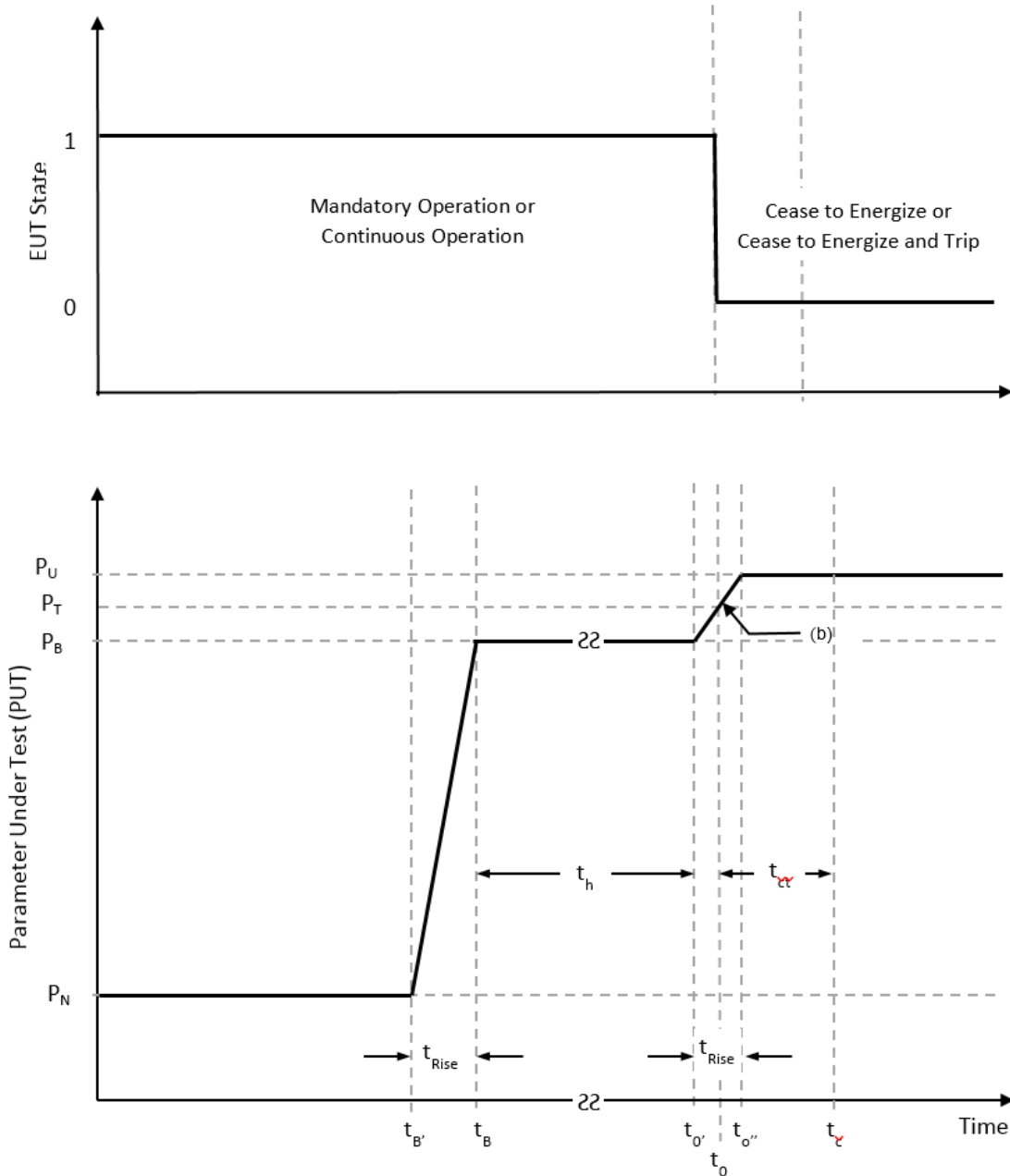

Notes:

- (a) Where the parameter under test is voltage, the rise times shall be as fast as possible and shall not exceed 2 cycles.
- (b) The hold time, t_h , shall be greater than or equal to 100% of the trip time setting plus 200% the minimum required measurement accuracy (MRA) for time, as specified in Table 3 of IEEE Std 1547-2018 for steady-state conditions.
- (c) The *clearing time* shall be measured from the time t_0 to t_c .

Figure A.2—Step change test signal

A.4 Rate limited step function

The test signal described in this subclause is used to characterize the behavior of protection settings for frequency tripping. A rate limited step function is utilized to avoid possible inadvertent tripping due to ROCOF.

Vary the parameter under test (PUT) according to the rate limited step function defined herein. Only the PUT shall be varied. Therefore, all other parameters shall be held at nominal values. The rate limited signal shall take the form described in [Equation \(A.2\)](#).

$$\text{For time } t_b' \text{ to } t_b: P(t) = A \times u(t_b - t_b') + P_N \quad (\text{A.2})$$

$$\text{For time } t_b \text{ to } t_0: P(t) = P_B$$

$$\text{For time } t_0' \text{ to } t_0'': P(t) = B \times v(t_0'' - t_0') + P_B$$

$$\text{For time } t_0'' \text{ to more than } t_{ci}: P(t) = P_U$$

where

P is the magnitude of the parameter under test (PUT) (V, f, P, Q , etc.)

t is time (s)

A, B scaling factors¹⁵⁹

$u(t), v(t)$ is the unit step functions¹⁶⁰

¹⁵⁹The scaling factors A and B needs to be chosen so that P_U is at least 110% (90% for under value tests) of P_T . *Exception:* For frequency tests, the scaling factor A needs to be chosen so that P_U is at least 101% (99% for under value tests) of P_T .

¹⁶⁰ $u = 0$ for $t < 0$ and $u = 1$ for $t \geq 0$.

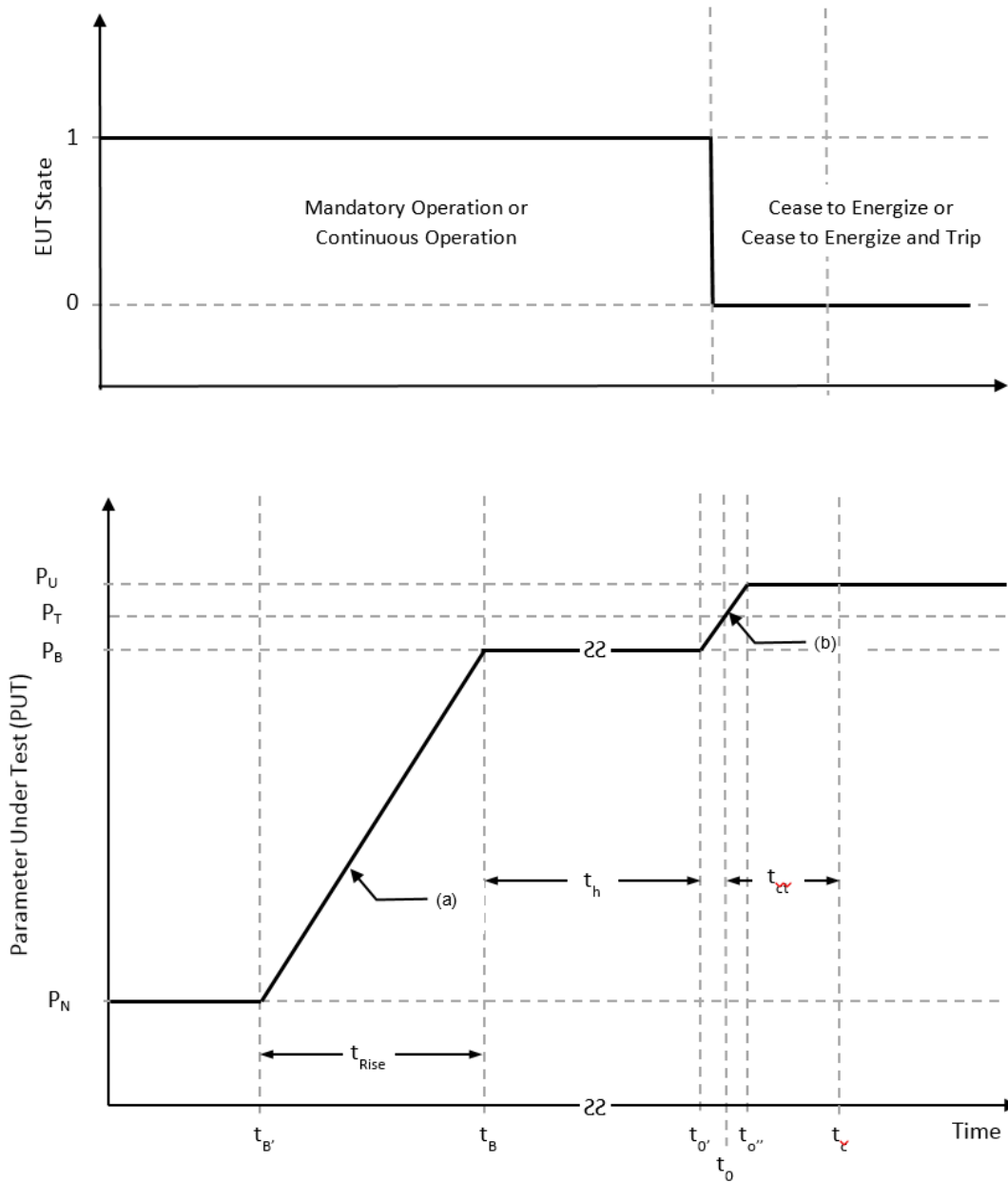

Notes:

- (a) Where the parameter under test is frequency, slope (a) shall be greater than or equal to the ROCOF limit in order to demonstrate compliance with the ROCOF requirement in 5.5.5.
- (b) Slope (b) should be chosen to be less than or equal to the ROCOF limit or, if greater than the ROCOF limit, within the demonstrated ROCOF capability of the EUT.
- (c) The hold time, t_h , shall be greater than or equal to 100% of the trip time setting plus 200% the minimum required measurement accuracy (MRA) for time, as specified in Table 3 of IEEE Std 1547-2018 for steady-state conditions.

Figure A.3—Rate-limited step change test signal

A.5 Reverse or minimum import power magnitude test (ramp function)

The test signal described in this subclause is used to characterize the accuracy of the reverse or minimum import power magnitude protection setting.

Vary the value of the current test signal according to the ramp function defined in this subclause. Only the current test signals shall be varied. Therefore, the voltage test signal shall be held at nominal values. The current test signal i shall take the form described in Equation (A.3).

$$i(t) = m \times r(t - t_0) + I_b \quad (\text{A.3})$$

where

- i is the current magnitude
- m is the slope of the ramp function
- r is the ramp function where $r = 0$ for $t < t_0$ and $r = t - t_0$ for $t > t_0$
- t is time (s)
- t_0 is the start time of the ramp
- I_b is the starting point of the ramp function¹⁶¹

The slope m is defined by Equation (A.4).

$$m = \frac{(0.5 \times a)}{(2 \times z)} \quad (\text{A.4})$$

where

- z is the *clearing time* setting (s) for the reverse or minimum import power protection parameter plus the manufacturer's stated *detection time* (s)
- a is the manufacturer's stated accuracy (MRA) of the reverse or minimum import power protection parameter

Figure A.4 is a graphical representation of a reverse or minimum import power magnitude test using the current ramp function.

When the ramp function conflicts with a design characteristic or settings of the EUT, an alternative method that is agreeable to the manufacturer and the *testing agency* may be used.

¹⁶¹The starting point I_b needs to be within 10% of, but not exceed, the trip point magnitude. At low settings, I_b may be zero.

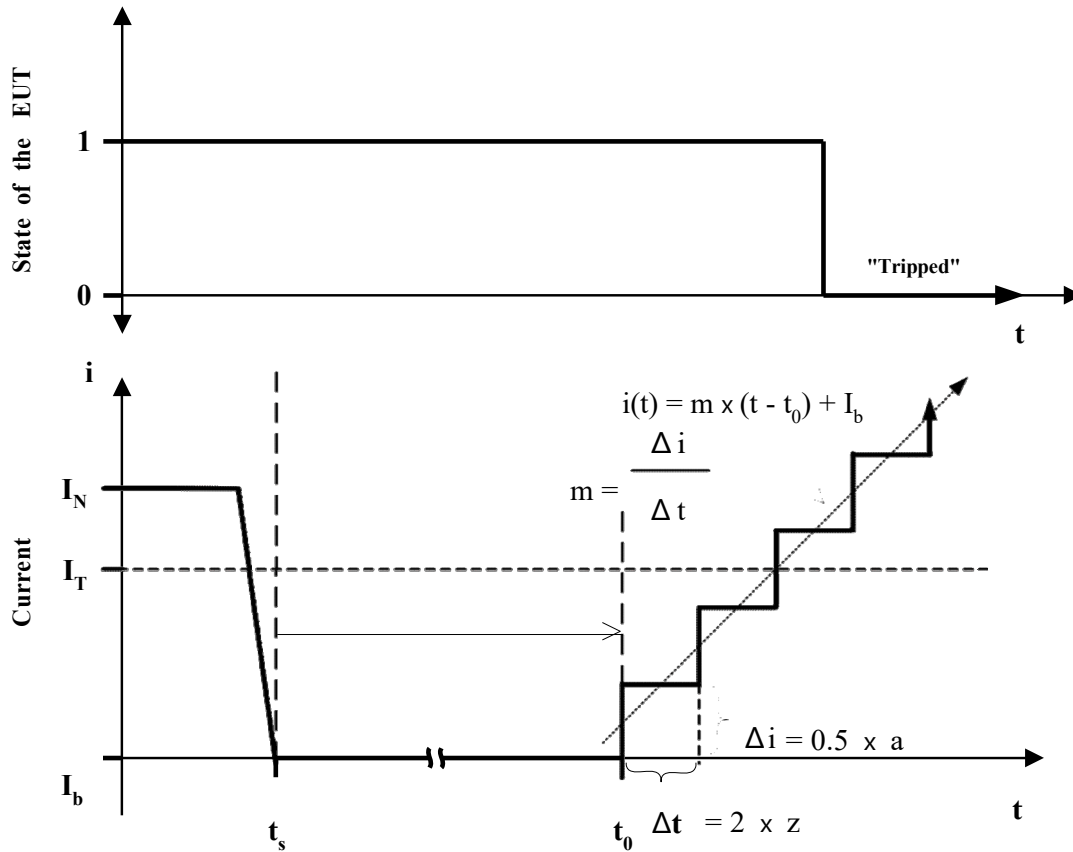

where

- i represents the current value
- t represents time
- I_N is the nominal current condition
- I_T is the trip magnitude¹⁶²
- t_0 is the start time of the ramp
- t_s is the instant when the phase transition occurs and the hold time¹⁶³ t_h for the test signal starts at starting point I_b

Figure A.4—Graphical representation of reverse or minimum import power magnitude test using current magnitude ramp function

A.6 Reverse or minimum import power time test (step function)

The test signal described in this subclause is used to characterize the accuracy of the *clearing time* setting for reverse or minimum import power protection parameter.

¹⁶²For the reverse-power magnitude test, the reverse-power trip magnitude will be a function of the magnitude of the current test signal because the voltage magnitude is at nominal and the phase difference between the voltage and current test signals, is 180°. Where the accuracy of the measurement is affected by p.f., design of the test regimen needs to accommodate various power factors.

¹⁶³The hold time t_h is at least two times the clearing time setting of the PUT. This number may be adjusted to avoid conflict with other trip points.

Vary the current test signal according to the test function defined in this subclause. Therefore, the voltage test signal shall be held at nominal values. The current test signal i shall take the form described in Equation (A.5).

$$i = A \times u(t - t_i) + I_b \quad (\text{A.5})$$

where

- i is the current test signal magnitude
- t is time (s)
- A is a scaling factor¹⁶⁴
- I_b is the starting point of the step function¹⁶⁵

Figure A.5 is a graphical representation of the functions used for a minimum import power time test.

When the step functions conflict with a design characteristic or settings of the EUT, an alternative method that is agreeable to the manufacturer and the *testing agency* may be used.

¹⁶⁴The scaling factor A should be chosen so that I_u is at least 110% of I_T .

¹⁶⁵The starting point P_b should be within 10% of, but not exceed, the trip point magnitude.

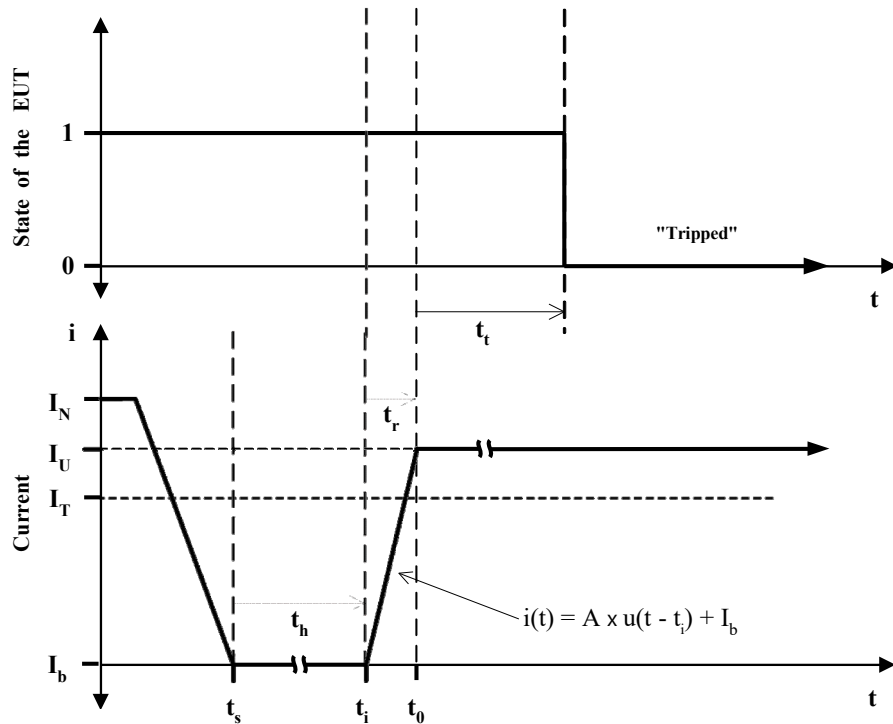

where

- i represents the current test signal
- t represents time
- t_t is the trip time
- I_N is the nominal current value
- I_T is the trip magnitude¹⁶⁶
- I_b is the starting value of the current step function
- I_U is the final value of the current step function
- t_0 is the start time used for calculating the trip time
- t_i is the start of the current step function
- t_r is the rise time of the test signal from $(t_0 - t_i)$ ^{167, 168}

Figure A.5—Graphical representation of reverse or minimum import power time test using current magnitude step function

¹⁶⁶For the reverse-power time test, the reverse-power trip magnitude will be a function of the magnitude of the current test signal, because the voltage magnitude is at nominal and the phase difference between the voltage and current test signals, is 180°.

¹⁶⁷The rise time t_r needs to be less than the larger of 1 cycle or 1% of the clearing time setting of the PUT.

¹⁶⁸The hold time t_h is at least two times the clearing time setting of the PUT. This number may be adjusted to avoid conflict with other trip points.

Annex B

(normative)

Results reporting format template

The template for results reporting described in 4.5 is posted on the IEEE Standards Association’s website at this location: <https://standards.ieee.org/downloads.html>.

The following table maps the functional parameter names as contained in Table 28 through Table 40 in Clause 10 of IEEE Std 1547-2018 to the data structure and naming convention specified in this standard.

IEEE Std 1547-2018 Parameter Name (where present)	IEEE Std 1547-2018 Parameter Label
Active power rating at unity power factor	NP_P_MAX
Active power rating at specified over-excited power factor	NP_P_MAX_OVER_PF
Specified over-excited power factor	NP_OVER_PF
Active power rating at specified under-excited power factor	NP_P_MAX_UNDER_PF
Specified under-excited power factor	NP_UNDER_PF
Apparent power maximum rating	NP_VA_MAX
Normal operating performance category	NP_NORMAL_OP_CAT
Abnormal operating performance category	NP_ABNORMAL_OP_CAT
Intentional island category (optional)	NP_INTENTIONAL_ISLAND_CAT
Reactive power injected maximum rating	NP_Q_MAX_INJ
Reactive power absorbed maximum rating	NP_Q_MAX_ABS
Active power charge maximum rating	NP_P_MAX_CHARGE
Apparent power charge maximum rating	NP_APPARENT_POWER_CHARGE_MAX
AC voltage base—nominal voltage rating(s)	NP_AC_V_NOM
AC voltage maximum rating Maximum	NP_AC_V_MAX
AC voltage minimum rating Minimum	NP_AC_V_MIN
Supported control mode functions	NP_SUPPORTED_MODES
Reactive susceptance (Not specified in IEEE Std 1547)	NP_REACTIVE_SUSCEPTANCE
Not supported in IEEE Std 1547	NP_REMOTE_METER_RESISTANCE
Not supported in IEEE Std 1547	NP_REMOTE_METER_REACTANCE
Manufacturer name	NP_MANUFACTURER
Model number	NP_MODEL
Serial number	NP_SERIAL_NUM
Firmware version number	NP_FW_VER
Permit service	ES_PERMIT_SERVICE
ES Voltage Low Setting	ES_V_LOW
ES Voltage High Setting	ES_V_HIGH
ES Frequency Low Setting	ES_F_LOW
ES Frequency High Setting	ES_F_HIGH
ES Randomized Delay	ES_RANDOMIZED_DELAY

IEEE Std 1547-2018 Parameter Name (where present)	IEEE Std 1547-2018 Parameter Label
ES Delay Setting	ES_DELAY
ES Ramp Rate Setting	ES_RAMP_RATE
Constant Power Factor Mode	CONST_PF_MODE_ENABLE
Constant Power Factor Excitation	CONST_PF_EXCITATION
Constant Power Factor Absorbing Setting	CONST_PF_ABS
Constant Power Factor Absorbing Setting	CONST_PF_INJ
Constant Reactive Power Mode Enable	CONST_Q_MODE_ENABLE
Constant Reactive Power Excitation (not specified in 1547)	CONST_Q_MODE_EXCITATION
Constant Reactive power setting (see Table 7)	CONST_Q
Voltage-Reactive Power Mode Enable	QV_MODE-ENABLE
Vref	QV_VREF
Autonomous Vref Adjustment Enable	QV_VREF_AUTO_MODE
Vref Adjustment time Constant	QV_VREF_OLRT
V/Q Curve Point V2 Setting	QV_CURVE_V2
V/Q Curve Point Q2 Setting	QV_CURVE_Q2
V/Q Curve Point V3 Setting	QV_CURVE_V3
V/Q Curve Point Q3 Setting	QV_CURVE_Q3
V/Q Curve Point V1 Setting	QV_CURVE_V1
V/Q Curve Point Q1 Setting	QV_CURVE_Q1
V/Q Curve Point V4 Setting	QV_CURVE_V4
V/Q Curve Point Q4 Setting	QV_CURVE_Q4
QV Open Loop Response Time Setting	QV_OLRT
Active Power Reactive Power Mode Enable	QP_MODE_ENABLE
P-Q curve P3 Setting	QP_CURVE_P3_GEN
P-Q curve P2P-Q Setting	QP_CURVE_P2_GEN
P-Q curve P1 Setting	QP_CURVE_P1_GEN
P-Q curve P3 Setting	QP_CURVE_P1_LOAD
P-Q curve P3 Setting	QP_CURVE_P2_LOAD
P-Q curve P3 Setting	QP_CURVE_P3_LOAD
P-Q curve P3 Setting	QP_CURVE_Q3_GEN
P-Q curve P3 Setting	QP_CURVE_Q2_GEN
P-Q curve P3 Setting	QP_CURVE_Q1_GEN
P-Q curve P3 Setting	QP_CURVE_Q1_LOAD
P-Q curve P3 Setting	QP_CURVE_Q2_LOAD
P-Q curve P3 Setting	QP_CURVE_Q3_LOAD
QP Open Loop Response Time Setting	QP_OLRT
Voltage-Active Power Mode Enable	PV_MODE_ENABLE
PV Curve Point V1 Setting	PV_CURVE_V1
PV Curve Point P1 Setting	PV_CURVE_P1
PV Curve Point V2 Setting	PV_CURVE_V2

IEEE Std 1547-2018 Parameter Name (where present)	IEEE Std 1547-2018 Parameter Label
PV Curve Point P2 gen Setting	PV_CURVE_P2_GEN
PV Curve Point P'2 load Setting	PV_CURVE_P2_LOAD
P(V) Open Loop Response time Setting	PV_OLRT
HV Trip Curve Point OV3 Setting	OV3_TRIP_V
HV Trip Curve Point OV3 Setting	OV3_TRIP_T
HV Trip Curve Point OV2 Setting	OV2_TRIP_V
HV Trip Curve Point OV2 Setting	OV2_TRIP_T
HV Trip Curve Point OV1 Setting	OV1_TRIP_V
HV Trip Curve Point OV1 Setting	OV1_TRIP_T
LV Curve Trip Point UV1 (see Table 11_ 13) Setting	UV1_TRIP_V
LV Curve Trip Point UV1 (see Table 11_ 13) Setting	UV1_TRIP_T
LV Curve Trip Point UV2 (see Table 11_ 13) Setting	UV2_TRIP_V
LV Curve Trip Point UV2 (see Table 11_ 13) Setting	UV2_TRIP_T
LV Curve Trip Point UV3 (see Table 11_ 13) Setting	UV3_TRIP_V
LV Curve Trip Point UV3 (see Table 11_ 13) Setting	UV3_TRIP_T
OF Curve Trip Point OF2 (see Table 19) Setting	OF2_TRIP_F
OF Curve Trip Point OF2 (see Table 19) Setting	OF2_TRIP_T
OF Curve Trip Point OF1 (see Table 19) Setting	OF1_TRIP_F
OF Curve Trip Point OF1 (see Table 19) Setting	OF1_TRIP_T
UF Curve Trip Point UF1 (see Table 19) Setting	UF1_TRIP_F
UF Curve Trip Point UF1 (see Table 19) Setting	UF1_TRIP_T
UF Curve Trip Point UF2 (see Table 19) Setting	UF2_TRIP_F
UF Curve Trip Point UF2 (see Table 19) Setting	UF2_TRIP_T
frequency-Active Power Mode Enable	PF_MODE_ENABLE
Overfrequency Droop dbOF Setting	PF_DBOF
Underfrequency Droop dbUF Setting	PF_DBUF
Overfrequency Droop kOF Setting	PF_KOF
Underfrequency Droop kUF Setting	PF_KUF
P(f) Open Loop Response Time Setting	PF_OLRT
N/A—AI is always on in IEEE Std 1547 BUT IEEE Std 1547.1 test says turn it off for <u>some</u> testing	UI_MODE_ENABLE
See IEEE Std 1547-2018 4.11.1	EMC_IMMUN_LEVEL

Annex C

(informative)

Calculation of test criteria considering uncertainty in input and output

This annex provides an example of the use of Equation (C.1) to calculate test criteria for DER control functions considering uncertainty in both the input parameter and the output parameter. Input and output parameters for the four relevant functions defined in IEEE Std 1547 are shown in Table C.1.

Table C.1—Input and output parameters for DER functions

DER function	Input parameter	Output parameter
Voltage-reactive power (volt-var) mode	Voltage	Reactive power
Active power-reactive power (watt-var) mode	Active power	Reactive power
Voltage-active power (volt-watt) mode	Voltage	Active power
Frequency droop (frequency-power) operation	Frequency	Active power

The test criteria for these four functions define the range of permissible values of the measured output parameter, Y , as a function of the measured value of the input parameter, X , in the *type tests* in Clause 5.

Taking the example of voltage-reactive power (volt-var) mode, where reactive power (Q) is controlled as a function of voltage (V), the steps to calculate the test criteria are as follows:

- a) Based on the functional description in IEEE Std 1547, define the output parameter as a mathematical function of the input parameter:

$$Q(V) = \begin{cases} Q_1, & V < V_1 \\ Q_1 + \frac{(V-V_1)(Q_2-Q_1)}{(V_2-V_1)}, & V_1 \leq V < V_2 \\ Q_2, & V_2 \leq V < V_3 \\ Q_3 + \frac{(V-V_3)(Q_4-Q_3)}{(V_4-V_3)}, & V_3 \leq V < V_4 \\ Q_4, & V_4 \leq V \end{cases} \quad (\text{C.1})$$

where

$Q_1, Q_2, Q_3,$ and Q_4 are the reactive power points defining the volt-var curve under test, as defined in Table 8 of IEEE Std 1547-2018

$V_1, V_2, V_3,$ and V_4 are the voltage points defining the volt-var curve under test, as defined in Table 8 of IEEE Std 1547-2018

This equation assumes $Q_2 = Q_3$ (i.e., a flat deadband region), which is not required by IEEE Std 1547 but is true of the volt-var curves tested in Clause 5.

- b) Run the volt-var test.
- c) For each measured test voltage V_{meas} , calculate the maximum and minimum permissible values of measured reactive power, Q_{min} and Q_{max} , respectively:

$$Q_{min} = Q(V_{meas} + 1.5 \times MRA(V)) - 1.5 \times MRA(Q)$$

$$Q_{max} = Q(V_{meas} - 1.5 \times MRA(V)) + 1.5 \times MRA(Q)$$

These equations leverage the fact that all volt-var curves tested in Clause 5 monotonically decrease; this is also true for all watt-var, volt-watt, and frequency-droop curves tested in Clause 5. $MRA(V)$ is 1% of nominal voltage, and $MRA(Q)$ is 5% of the EUT’s rated apparent power, per Table 3 of IEEE Std 1547-2018. Graphically, the equation for Q_{max} is equivalent to shifting the volt-var curve to the right by $1.5 \times MRA(V)$ and upwards by $1.5 \times MRA(Q)$, as shown in Figure C.1 for the example of the default volt-var curve for normal operating performance Category B. Likewise, Q_{min} is obtained by shifting the volt-var curve left by $1.5 \times MRA(V)$ and down by $1.5 \times MRA(Q)$, also shown in Figure C.1 for the same volt-var curve.

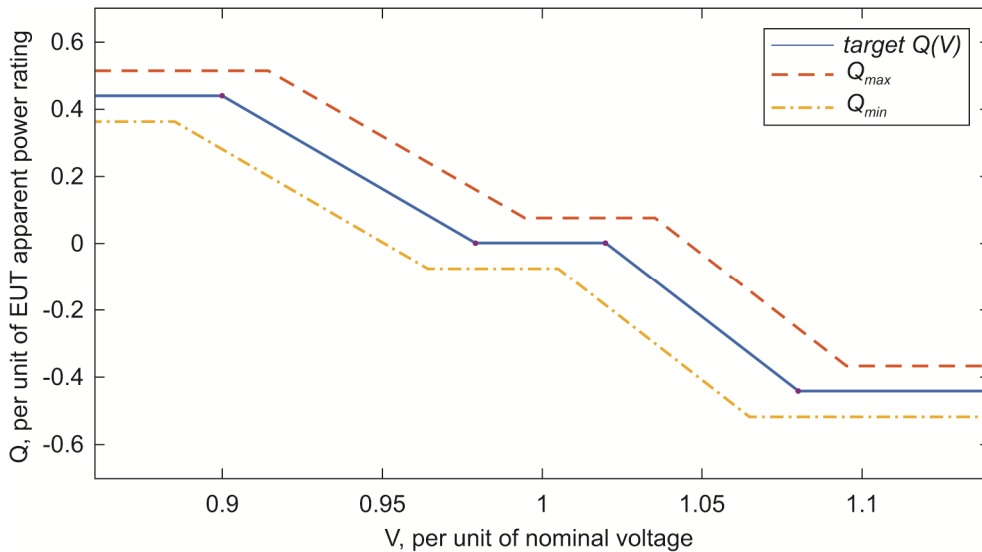

Figure C.1—Example of test criteria for voltage-reactive power (volt-var) mode

A similar approach applies to the remaining DER functions, with the equation in step a) replaced by the relevant equation for the function under test. Note that in the case of volt-watt mode, only the upper bound applies; there is no lower limit on EUT active power in volt-watt mode.

Annex D

(informative)

Unintentional islanding of DER

This annex provides background information in support of the unintentional islanding testing in 5.10.

An *ac test source* for unintentional islanding is any source capable of operating within the recommended voltage and frequency window. An engine-generator with voltage and frequency control and without islanding protection may be considered an *ac test source* for this test.

Harmonic currents that flow between the *ac test source*, the RLC load, and the DER, complicate the situation by making it appear that current is flowing when the fundamental frequency component of current has been reduced to less than 0.02 p.u. at S3. Thus, it is important, when adjusting inductive and capacitive reactance, to use instruments that can display the fundamental frequency component of current and power.

It is preferred to adjust inductance first in balancing the RLC load. The capacitance is added next so that the voltage is stable when the resistance is added. The resistive parallel load is added last. Note that this resistance is in addition to the resistance that is inherently part of the inductive load.

A grid intertied synchronous generator typically regulates real power (in kilowatts) irrespective of grid frequency, and it regulates reactive power (in kilovars) or p.f. regardless of voltage level on the grid. The control systems inherent in synchronous machines may possibly maintain an unintentional island, but this condition depends on the load applied being closely matched to the synchronous generator output.

Note also that the change in active power requires a change in the fuel rate to the engine, and the change in the reactive power requires a change in the excitation rate in the synchronous generator. Because the excitation rate can be changed much faster than the fuel rate, the protection scheme for unintentional island detection should consider the characteristics required for proper operation in compliance with the requirements of IEEE Std 1547.

The synchronous machine can maintain ac output when islanded, but the frequency of the output is not related to the inductive and capacitive nature of the loads on the machine as it is in some inverter-based machines.

Island voltage V_{island} and *island* frequency f_{island} are modeled by the following equations:

$$f_{\text{island}} = f_{\text{eps}} \times [(Q_L + Q_{Li}) / (Q_C + Q_{Ci})]^{1/2}$$

$$V_{\text{island}} = V_{\text{eps}} \times [P_{\text{gen}} / P_{\text{load}}]^{1/2}$$

$$QF = [(Q_L + Q_{Li}) \times (Q_C + Q_{Ci})]^{1/2} / P_{\text{load}}$$

where

QF	is the effective quality factor of the test setup
P_{gen}	is the active (real) output power of the EUT (W)
P_{load}	is the active (real) load of the resistance (W)
f_{eps}	is the frequency of the ac test source (Hz)
f_{island}	is the computed <i>island</i> frequency of the test setup (Hz)
V_{eps}	is the voltage of the ac test source (V)
V_{island}	is the computed <i>island</i> voltage of the test setup (V)

IS 18969 : 2024

Q_L	is the reactive power of the inductive load (var)
Q_{Li}	is the inductive reactive power of the EUT (var)
Q_C	is the reactive power of the capacitive load (var)
Q_{Ci}	is the capacitive reactive power of the EUT (var)

Annex E

(informative)

IEC 61850-7-420 information model usage

E.1 General communication commissioning

This annex provides the information model defined by IEC 61850-7-420 exchanged using IEC 61850-8-1 or IEC 61850-8-2. This information may be of interest since the IEEE Std 1547-2018 requirement does not preclude the use of additional protocols.

E.2 Nameplate data test

If the IEC 61850-7-420 information model is used, IEEE 1547 nameplate data shall be associated with IEC 61850-7-420 data objects (DO) as specified in [Table E.1](#).

For most generation-related data objects, the logical node (LN) DGEN is indicated. However, for storage-specific data objects, LN DSTO is indicated. For some *nameplate ratings* that are not specific to either generation or storage (e.g., voltage ratings, power factor ratings), LN DGEN is indicated, but LN DSTO could also be used for storage DERs since it “inherits” the same abstract data objects.

Table E.1—Nameplate data test

Nameplate data requirement in IEEE Std 1547-2018	IEC 61850 data object (LN.DO)	Clarification and additional test instructions
Active power rating at unity power factor (nameplate active power rating)	DGEN.WMaxRtg	
Active power rating at specified over-excited power factor	DGEN.WGnOvPFRtg	
Specified over-excited power factor	DGEN.OvPFRtg	
Active power rating at specified under-excited power factor	DGEN.WGnUnPFRtg	
Specified under-excited power factor	DGEN.UnPFRtg	
Apparent Power Maximum Rating	DGEN.VAMaxRtg	
Normal operating performance category	DGEN.Ieee1547Cat1	Special DO for IEEE Std 1547-2018
Abnormal Operating Performance Category	DGEN.Ieee1547Cat2	Special DO for IEEE Std 1547-2018
Reactive Power Injected Maximum Rating	DGEN.VarMaxSupRtg	
Reactive Power Absorbed Maximum Rating	DGEN.VarMaxAbgRtg	
Active Power Charge Maximum Rating	DSTO.WChaUnPFRtg	Optional for generating-only DER
Apparent Power Charge Maximum Rating	DSTO.VAMaxChaRtg	Optional for generating-only DER
AC voltage nominal rating	DECP.VRef	
AC voltage maximum rating	DGEN.VMaxRtg	
AC voltage minimum rating	DGEN.VMinRtg	
Supported Control Mode Functions	DVRT, DFRT, DFWP, DWLM, DVWC, DFWC, DVAR, DFPF, DVVC, DWVR	Supported if the LN exists; use the Get Logical Nodes capability
Reactive susceptance that remains connected to the <i>area EPS</i> in the cease-to-energize and trip state	DGEN.SuscRtg	
Manufacturer	LPHD.PhyNam.vendor	
Model	LPHD.PhyNam.model	
Serial Number	LPHD.PhyNam.serNum	
Version	LPHD.PhyNam.swRev	
Nameplate Storage Actual Capacity	DSTO.WhRtg	

E.3 Configuration information

For DER using IEC 61850, there are data objects for configuration (operational) information, although most ratings remain as the same DOs as the nameplate DOs (shown as gray in Table E.2).

Table E.2—Configuration information

Nameplate data requirement in IEEE Std 1547-2018	IEC 61850 data object (LN.DO)	Clarification and additional test instructions
Active power rating at unity power factor (nameplate active power rating)	DGEN.WMax	
Active power rating at specified over-excited power factor	DGEN.WGnOvPFRtg	
Specified over-excited power factor	DGEN.OvPFRtg	
Active power rating at specified under-excited power factor	DGEN.WGnUnPFRtg	
Specified under-excited power factor	DGEN.UnPFRtg	
Apparent Power Maximum Rating	DGEN.VAMax	
Normal Operating Performance Category Abnormal Operating Performance Category	DGEN.RegCap	Text stating: “IEEE Std 1547-2018 Normal Category A (B) & Abnormal Category I (II, III),”, where either “A” or “B” is stated for the Normal Category and either “I”, “II”, or “III” is stated for the Abnormal Category
Reactive Power Injected Maximum Rating	DGEN.VarMaxSupRtg	
Reactive Power Absorbed Maximum Rating	DGEN.VarMaxAbgRtg	
Active Power Charge Maximum Rating	DSTO.WChaUnPFRtg	Optional for generating-only DER
Apparent Power Charge Maximum Rating	DSTO.VAMaxChaRtg	Optional for generating-only DER
AC voltage nominal rating	DECP.VRef	
AC voltage maximum rating	DGEN.VMax	
AC voltage minimum rating	DGEN.VMin	
Supported Control Mode Functions	DVRT, DFRT, DFWP, DWLM, DVWC, DFWC, DVAR, DFPF, DVVC, DWVR	Supported if the LN exists
Reactive susceptance that remains connected to the <i>area EPS</i> in the cease-to-energize and trip state	DGEN.SuscRtg	
Manufacturer	LPHD.PhyNam.vendor	
Model	LPHD.PhyNam.model	
Serial Number	LPHD.PhyNam.serNum	
Version	LPHD.PhyNam.swRev	
Nameplate Storage Actual Capacity	DSTO.WhRtg	

E.4 Monitoring information

See [Table E.3](#).

Table E.3—Monitoring information

IEEE 1547 monitoring information requirement	IEC 61850 data object (LN.DO)	Clarification and additional test instructions
Active Power	DECP.MMXU.TotW	
Reactive Power	DECP.MMXU.TotVAr	
Voltage(s)	DECP.MMXU.PhV.phsA.mag DECP.MMXU.PhV.phsB.mag DECP.MMXU.PhV.phsC.mag	These are the phase A, B, and C voltages respectively. For single-phase systems, only Phase A voltage is required.
Frequency	DECP.MMXU.Hz	
Operational State	DGEN.DERState	Off = 1 disconnected and stand-by = 2 disconnected and available = 3 disconnected and authorized = 4 starting and synchronizing = 5 connected and idle = 6 connected and generating = 7 connected and consuming = 8 stopping = 9 disconnected and blocked = 10 disconnected and in maintenance = 11 ceased to energize = 12 failed = 13
Connection Status	DSTO.DERState.1	See Operational State
Alarm Status	CALH.GrAlm	
Operational State of Charge	DSTO.SocUsePct	Usable State of Charge (percent of total usable capacity) which may be directly measured or calculated

E.5 Constant power factor

In IEC 61850-7-420, the constant power factor control function is LN DFPF. The power factor sign convention is set by the data object MMXU.PFSign. See [Table E.4](#).

Table E.4—Constant power factor

Constant power factor function	IEC 61850 data object (LN.DO)	Clarification and additional test instructions
Constant power factor mode enable	DFPF.ModEna	
Constant power factor setting	DFPF.PFGnTgt DFPF.PFLodTgt	PFGnTgt applies when generating. Target power factor setting when generating. The power factor target is a number between -1 and 1, and it is used in conjunction with PFExtSet to indicate whether to make it over or under excited. PFLodTgt applies when charging and need not be supported for generating-only DER.
Constant power factor excitation setting	DFPF.PFExtSet	PFExtSet: PFExtSet set to true = overexcited; PFExtSet set to false = underexcited

E.6 Voltage-reactive power

In IEC 61850-7-420, the voltage-reactive power (volt-var) function is LN DVVR while the voltage settings are in LN DECP. See [Table E.5](#).

Table E.5—Voltage-reactive power

Voltage-reactive power (volt-var) function	IEC 61850 data object (LN.DO)	Clarification and additional test instructions
Voltage-Reactive Power Mode Enable	DVVR.ModEna	
V_{Ref} Reference Voltage	DECP.VRef	
Autonomous V_{Ref} Adjustment Enable	DECP.VRefOfs	
V_{Ref} Adjustment Time Constant	DVVR.VRefTmms	The time (in ms) over which to sample voltage through a low pass filter to create an average voltage over that time.
V/Q Curve Points	DVVR.VVArCrv	Curve of volt-var points
Open Loop Response Time	DVVR.OpnLoopMax	

E.7 Active power-reactive power

In IEC 61850-7-420, the active power-reactive power (watt-var) function is LN DWVR. See [Table E.6](#).

Table E.6—Active power-reactive power

Active power-reactive power (watt-var) function	IEC 61850 data object (LN.DO)	Clarification and additional test instructions
Active-Reactive Power Mode Enable	DWVR.ModEna	
P/Q Curve Points	DWVR.WVArCrv	Curve of watt-var points

E.8 Constant reactive power

In IEC 61850-7-420, the constant reactive power (fixed var) function is LN DVAR. See [Table E.7](#).

Table E.7—Constant reactive power

Constant reactive power (fixed var) function	IEC 61850 data object (LN.DO)	Clarification and additional test instructions
Constant Reactive Power Mode Enable	DVAR.ModEna	
Constant Reactive Power	DVAR.VArTgt	

E.9 Voltage-active power

In IEC 61850-7-420, the voltage-active power (volt-watt) function is LN DVWC. See [Table E.8](#).

Table E.8—Voltage-active power

Voltage-active power (volt-watt) function	IEC 61850 data object (LN.DO)	Clarification and additional test instructions
Voltage-Active Power Mode Enable	DVWC.ModEna	
V/P Curve Points	DVWC.VWCrv	Curve of volt-watt points
Open Loop Response Time	DVWC.OpnLoopMax	

E.10 Voltage trip

In IEC 61850-7-420, the voltage-trip function is LN DHVT for high voltage and LN DLVT for low voltage. The trip curves are modeled in PTOV and PTUV. DHVT.ModEna and DLVT.ModEna are used for enabling and disabling the function. See [Table E.9](#).

Table E.9—Voltage trip

Voltage trip function	IEC 61850 data object (LN.DO)	Clarification and additional test instructions
HV Trip Curve Points	DHVT.TrZnSt PTOV.TmVCrv	Status of high-voltage trip function Trip function <i>V</i> -time curve
LV Trip Curve Points	DLVT.TrZnSt PTUV.TmVCrv	Status of low-voltage trip function Trip function <i>V</i> -time curve

E.11 Momentary cessation

In IEC 61850-7-420, the voltage-momentary cessation function is LN DHVT for high voltage and LN DLVT for low voltage. The momentary cessation curves are modeled in PTOV and PTUV. See [Table E.10](#).

Table E.10—Momentary cessation

Voltage momentary cessation function	IEC 61850 data object (LN.DO)	Clarification and additional test instructions
HV Trip Curve Points	DHVT.CeaZnSt PTOV.TmVCrv	Status of high-voltage momentary cessation function Momentary cessation function <i>V</i> -time curve
LV Trip Curve Points	DLVT.CeaZnSt PTUV.TmVCrv	Status of low-voltage momentary cessation function Momentary cessation function <i>V</i> -time curve

E.12 Frequency trip

In IEC 61850-7-420, the frequency-trip function is LN DHFT for high voltage and LN DLFT for low voltage. The trip curves are modeled in PTOF and PTUF. DHFT.ModEna and DLFT.ModEna are used for enabling and disabling the function. See [Table E.11](#).

Table E.11—Frequency trip

Frequency-trip function	IEC 61850 data object (LN.DO)	Clarification and additional test instructions
HF Trip Curve Points	DHFT.TrZnSt PTOF.StrVal	Status of high-frequency trip function Frequency or frequency rate change setting; if this level is exceeded and other settings permit it, the device trips.
LF Trip Curve Points	DLFT.TrZnSt PTUF.StrVal	Status of low-frequency trip function Frequency or frequency rate change setting; if this level is exceeded and other settings permit it, the device trips.

E.13 Frequency droop (frequency-watt)

In IEC 61850-7-420, the frequency droop function is LN DHFW for high frequency and LN DLFW for low frequency. DHFW.ModEna and DLFW.ModEna are used for enabling and disabling the function. See [Table E.12](#).

Table E.12—Frequency droop (frequency-watt)

Frequency droop function	IEC 61850 data object (LN.DO)	Clarification and additional test instructions
Overfrequency Droop db_{OF}	DHFW.HzStr	The frequency that must be higher than the reference frequency at which to start reducing power output.
Underfrequency Droop db_{UF}	DLFW.HzStr	The frequency that must be lower than the reference frequency at which to start increasing power output.
Overfrequency Droop k_{OF}	DHFW.WGra	Decreasing active power gradient
Underfrequency Droop k_{UF}	DLFW.WGra	Increasing active power gradient
Open Loop Response Time	DHFW.OpnLoopMax DLFW.OpnLoopMax	

E.14 Enter service

In IEC 61850-7-420, the enter service function is LN DCTE. See [Table E.13](#).

Table E.13—Enter service

Enter service function	IEC 61850 data object (LN.DO)	Clarification and additional test instructions
Permit service	DCTE.RtnSrvAuto DCTE.RtnSrvAuth	If true, the DER is authorized to automatically return to service; if false, the DER must wait until an external RtnSrvAuth is received to allow it to return to service.
ES Voltage High	DCTE.VHiLim	
ES Voltage Low	DCTE.VLoLim	
ES Frequency High	DCTE.HzHiLim	
ES Frequency Low	DCTE.HzLoLim	
ES Delay	DCTE.RtnSrvDlyTim	Return to service duration that is a time for ramping up that must not be exceeded. Active power shall increase linearly, or in a stepwise linear ramp, with an average rate-of-change not exceeding the DER nameplate active power rating divided by this return to service duration.
ES Randomized Delay	DCTE.RtnSrvDlyTim	Random time within this delay time.
ES Ramp Time	DCTE.RtnSrvRmpTim	Time, not rate.

E.15 Limit maximum active power

In IEC 61850-7-420, the limit maximum active power function is LN DWMX for high limit and LN DWMN for low limit. See [Table E.14](#).

Table E.14—Limit maximum active power

Constant reactive power (fixed var) function	IEC 61850 data object (LN.DO)	Clarification and additional test instructions
Limit Active Power Enable	DWMX.ModEna DWMN.ModEna	
Maximum Active Power	DWMX.LimW DWMN.LimW	

Annex F

(informative)

Hardware-in-the-loop based testing

F.1 Terminology

Hardware-in-the-loop based testing may be used as an alternative test approach as described in the corresponding test procedures herein. While the HIL-related test setup requirements and procedures are given in the respective clauses, this informative clause provides information on terminology used in HIL test setups including the corresponding subsystems and their interconnections.

The following are HIL-related terms used in this document:

- **Digital real-time simulator (DRTS):** A digital real-time simulator (DRTS) is an integral part of HIL test setups and simulates a model (rest-of-system, ROS) in real-time, provides interfaces to exchange signals between the simulated subsystem and external hardware, and controls the test conditions at the terminals of the EUT. For electric subsystems, which interface to the device under test, electromagnetic transient type modeling and simulation approach shall be used.
- **Interface algorithm (IA):** An interface algorithm in the context of PHIL is a method of linking a DRTS simulated subsystem to a power device under test. For example, a power interface (amplifier) may be used as a controlled voltage source and its measured current fed back into the simulated system. Several interface algorithms are available; see, for example Lundstrom, et al. [B26], UL 1741 [B27].
- **Low-power input/output interfaces:** Low-power input/output (I/O) interfaces provide the means to interface signals that control power equipment or controls as part of HIL-based testing. Typically, analog I/O-signals are in the range of 0–10 V and digital signals follow standards such as transistor-transistor logic (TTL). These interfaces may also use digital communication protocols to exchange information.
- **Power amplifier (PA):** Power amplifiers receive reference signals that reflect voltages and/or currents of simulated subsystems. The amplifier transforms the reference signals to voltages and/or currents at its power terminals to interact with the EUT.
- **Power interface:** A power interface links the signals of the simulated subsystem to the power equipment under test. A power amplifier enables the interface by amplifying the low-power reference signals to voltages and/or currents as provided by the DRTS.
- **Rest-of-system (ROS):** HIL tests require models to be simulated in real-time on the DRTS to close the loop between the simulated subsystem and EUT. Properties and requirements of models are specific to a HIL test. In PHIL experiments, the simulated subsystem provides the reference signals for the power amplifiers and receives voltages and/or currents as feedback. The rest-of-system (ROS) refers to the real-time simulated subsystem that is executed on the DRTS and interfaced to the EUT.

The salient subsystems and interconnections for a power HIL test setup and as introduced above are depicted in [Figure F.1](#). Besides the ROS, the DRTS may be used to provide additional control commands as required in test procedures and protect the test setup as indicated by the auxiliary component.

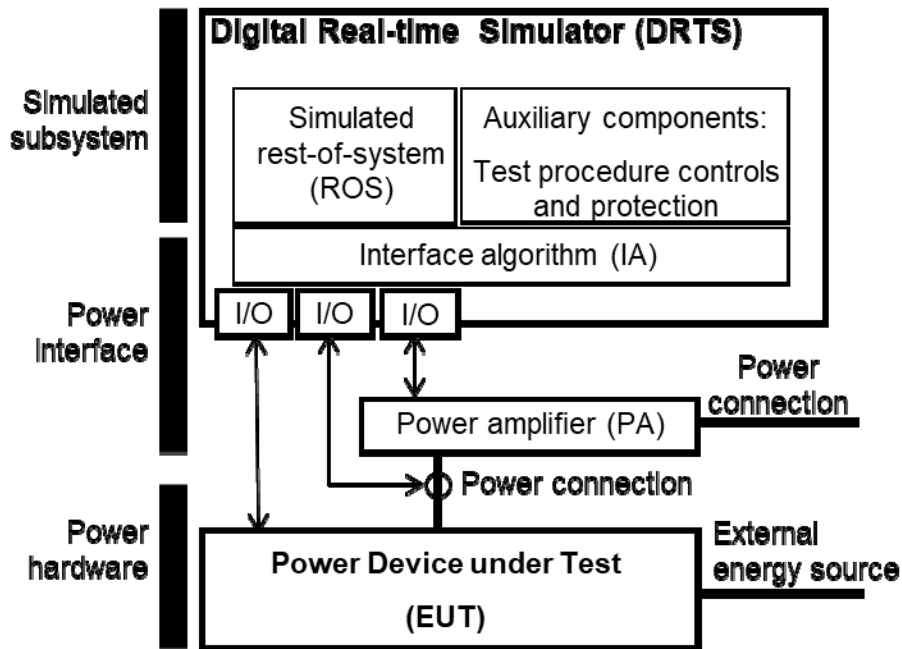
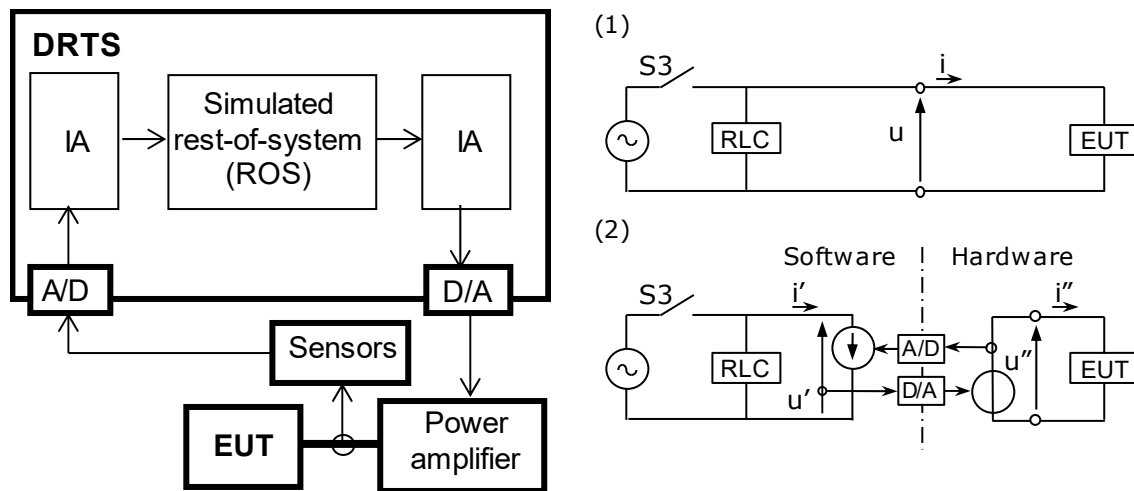

Figure F.1—Power hardware-in-the-loop test setup overview

A depiction of a closed-loop power HIL test setup is shown in Figure F.2. Several interface algorithms (IA) are available to link the real-time simulated ROS model within the DRTS to the external EUT. The power amplifier may be controlled to produce necessary voltages or currents at the terminals of the EUT, and currents and voltages may be fed back into the simulated subsystem. A single-phase example of such a setup that may be used in PHIL-based unintentional islanding tests is shown in Figure F.2 (b). A software model replaces the grid voltage source, switch S3, and RLC-load bank.



(a) Interface algorithm linking real-time simulated ROS with power amplifier and EUT to form a closed-loop system.

(b) Example of linking the EUT to the real-time simulated ROS subsystem in unintentional islanding tests: (1) depicts the unintentional islanding test circuit with dedicated RLC-load bank and (2) depicts a corresponding PHIL test setup.

Figure F.2—Linking the simulated ROS with the EUT in PHIL tests

The link between the ROS and EUT is established by providing the voltage as measured in the simulation through the power amplifier at the terminals of the EUT. In turn, the measured EUT's current is fed back into the simulated ROS. Details to consider in establishing the unintentional islanding PHIL and ROS are to be taken from the respective clause.

A depiction of Controller HIL is given in Figure F.3 (a). A real-time simulated ROS is providing signals used as measurements by the EUT, and the EUT's response is fed back into the real-time simulation. Though the corresponding interacting signals do not occur at the EUT's power level, actuators and sensors may be necessary to match the EUT's voltage and current levels. Relay testing is given as a CHIL-example application in Figure F.3 (b), and it may require potential and current transformers to interact with the EUT. The EUT controls the breaker status as based on the perceived operating conditions, i.e., voltage and current.

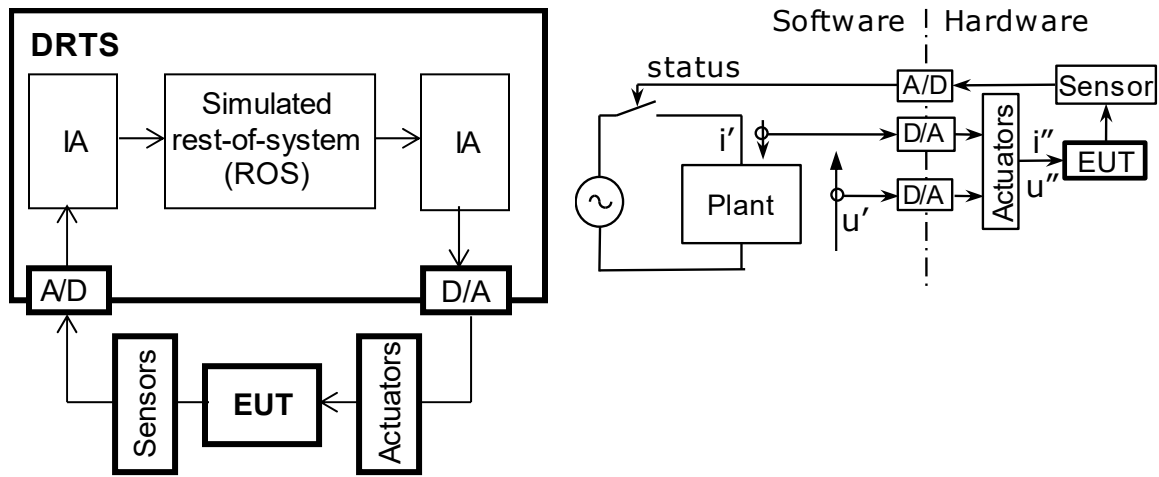

(a) Interfacing EUT to the simulated ROS in a CHIL test setup.

(b) Example application: linking the EUT to the simulated ROS subsystem in relay testing through actuators and sensors if required to adjust voltage and current levels, e.g., potential and current transformers.

Figure F.3—Linking the simulated ROS with the EUT in CHIL tests

F.2 Controller hardware-in-the-loop testing for *supplemental DER devices*

Supplemental DER devices may be tested using a DRTS and an appropriate analog or digital input/output interface. This interface between the *supplemental DER device* and the DRTS is a low-power signal, such as a voltage or current measurement signal, specifically not the power terminals of the DER. In instances where the DRTS I/O signal levels do not match the *supplemental DER device*, an analog or digital buffer may be used such as a relay test set amplifier for generating 5 A or 120 V signals to mimic current transformer and potential transformer secondary signals.

Design evaluation studies may benefit from this method since *supplemental DER devices* do not fit within the scope for type testing. Controller HIL testing can show correct functionality of a *supplemental DER device* within a larger *DER system* prior to installation in a field site. It is suggested to use a DRTS simulation time-step of 50 μ s or smaller to sufficiently model transient effects.

Both inputs and outputs of the *supplemental DER devices* should be connected such that the simulated system is affected by internal functions of the *supplemental DER device*. Justification should be included for holding an input or output fixed during a test.

The example in Figure F.4 shows a protection relay test configuration with analog measurements from the DRTS coupled to a test set and dry-contact output back into the DRTS for breaker control.

The example in Figure F.5 shows a *plant controller* where inputs and outputs are both digital communication channels. PCC measurements are communicated to the controller inputs and commands are sent back out over a communication channel to the controlled *DER units*.

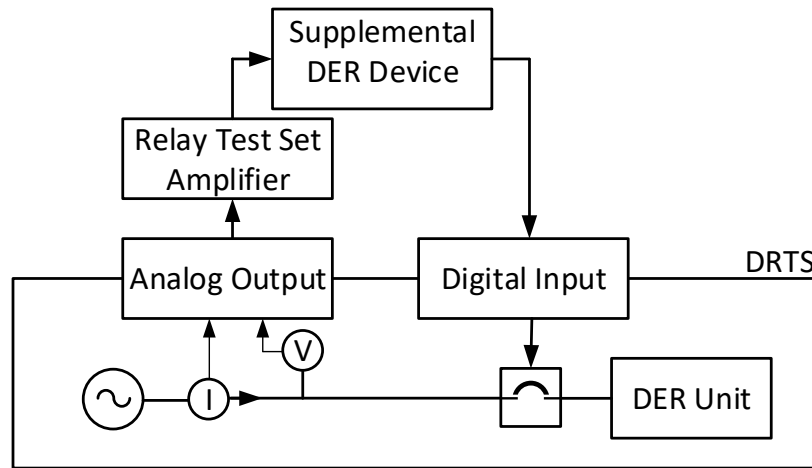

Figure F.4—An example of using a Controller HIL-test setup to confirm operation of *supplemental DER devices*

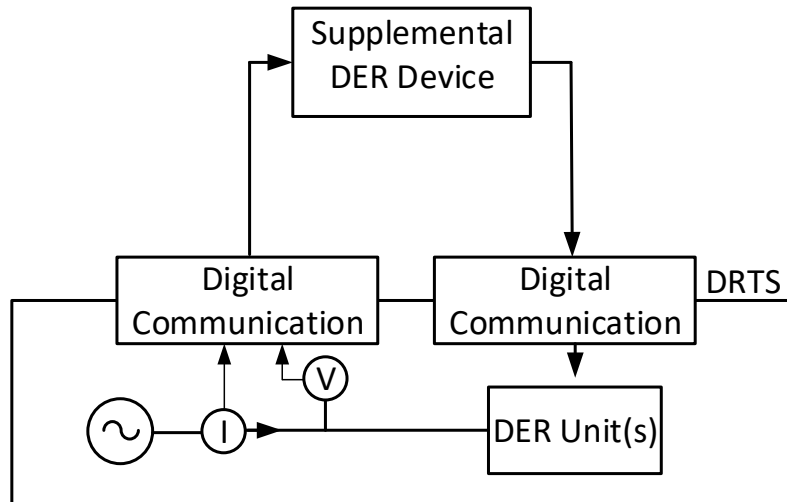

Figure F.5—An example of using a Controller HIL-test setup to confirm operation of a *plant controller (a supplemental DER device)*

F.3 Additional information on PHIL test setup requirements in testing unintentional islanding

As outlined in the unintentional islanding *type tests*, the PHIL-approach may be used to confirm compliance, as first proposed in UL 1741 [B27]. The following provides additional information on verifying that the PHIL test setup fulfills all necessary requirements.

As introduced in the main body of this document, the impedance characteristics of the real-time simulated RLC-load bank as seen from the EUT's terminals may be used to demonstrate fulfilling the PHIL test setup requirements. The following are depictions of the magnitude (see Figure F.6) and phase (see Figure F.7) following the magnitude and phase angle requirements as stated within 5.10.2.3 and repeated here:

- Magnitude requirement: for $f_{LL} \leq f \leq f_{UL}$ the impedance magnitude $|Z|$ shall be within a magnitude range $|\Delta Z|$ about the simulated RLC-load with

$$|\Delta Z| = \max(2.5\%, 2.5\% + (f - 60 \text{ Hz}) / f_{UL} \times 30\%).$$

- Phase requirement: for $f_{LL} \leq f \leq f_{UL}$ the impedance phase $\angle(Z)$ shall be within a phase range $\angle(\Delta Z)$ of the simulated RLC-load bank with

$$\angle(\Delta Z) = \max(4^\circ, 4 + (f - 60 \text{ Hz}) / f_{UL} \times 41^\circ).$$

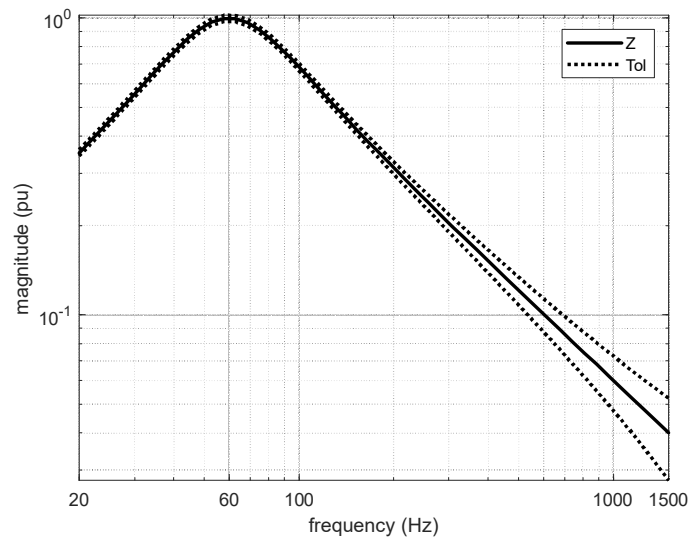

Figure F.6—Impedance magnitude requirement: nominal impedance (solid) and tolerance bounds (dotted)

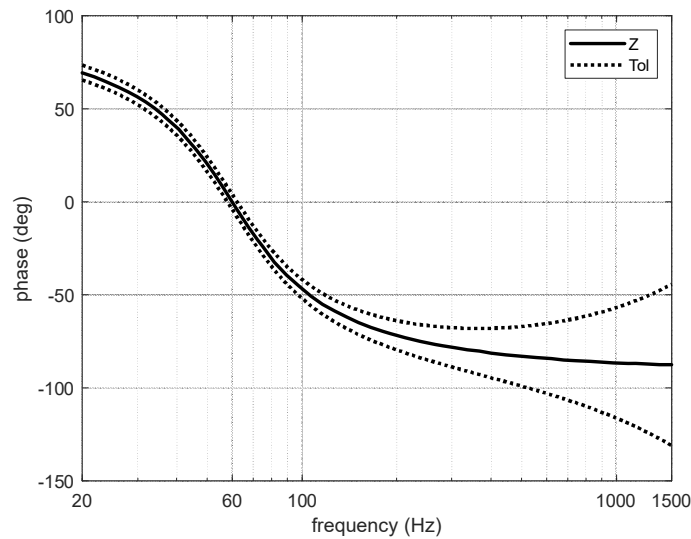

Figure F.7—Impedance phase requirement: nominal phase (solid) and tolerance bounds (dotted)

F.4 Measuring impedance characteristics

The apparent RLC-load bank impedance as seen from the device under test may be verified to adhere to the specified characteristics in PHIL-based unintentional islanding testing. Multiple practical options are available in measuring impedances, see for example [B2], [B3], and [B4]. One approach that may be used in determining impedance characteristics is based on voltage or current injections as shown in Figure F.8. As introduced above, the simulated subsystem includes a grid voltage source behind switch S3 and an RLC-load bank model. An interface algorithm (IA), which includes the PHIL-power amplifier and interface transformer as used in PHIL-unintentional islanding tests, is used to link the simulated subsystem to the power circuit. The hardware power circuit includes a source system to establish the desired operating conditions and capabilities to inject either a voltage in series or a current in shunt. The IA used in measuring the impedance characteristics should be the same as used in the PHIL-based unintentional islanding tests. The simulated RLC-load bank characteristics shall follow the requirements as given in 5.10.2.3. Though the voltages or current injections may be realized through separate means, the impedance probing injections may also be directly realized through the source system, which may be a controllable voltage or current source.

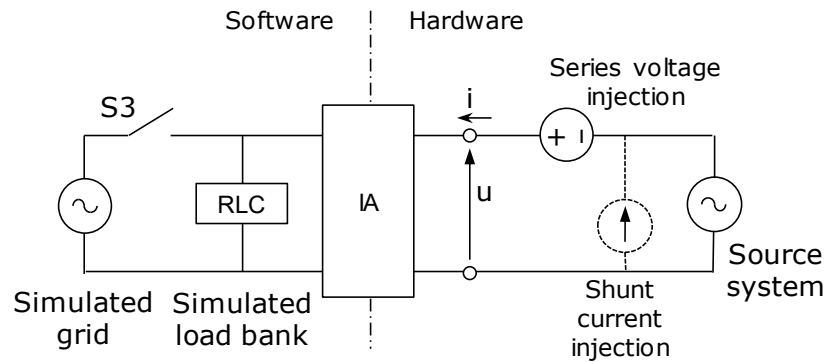

Figure F.8—Impedance measurement setup example: injecting voltages or currents

While the source system establishes the operating point conditions including fundamental voltage magnitude and frequency, the injected voltages (or currents) provide small probing signals to establish impedance characteristics. Note that the simulated switch S3 is to be in the open position. Measuring voltage and current (marked as voltage u and current i in [Figure F.8](#)) while injecting oscillations at selected frequencies f allows to determine the impedance characteristic $Z(f)$ after extracting the corresponding frequency components $V(f)$ and $I(f)$. The injected and measured oscillatory components may be appropriately selected but their magnitudes are expected to be in the low percentage range with respect to nominal values. For efficiency, multiple frequency components may be injected at a time. The test setup as shown reflects single-phase and single-phase equivalent of symmetric three-phase systems.

Annex G

(informative)

Short circuit simulator

G.1 Purpose

This annex describes one possible method for performing low-voltage disturbance ride-through tests using equipment referred to as a short-circuit simulator.

This method uses test equipment capable of producing the required voltage sags specified in 6.3.2 of IEEE Std 1547-2018. The test equipment comprises of a short-circuit simulator utilizing the voltage divider principle implemented via a series reactor and a short-circuit choke. Figure G.1 shows a schematic representation of the entire test setup. The test equipment as described is intended for low-voltage ride-through (LVRT) testing of three-phase EUT either for symmetric or asymmetric line-to-ground or line-to-line voltage disturbances.

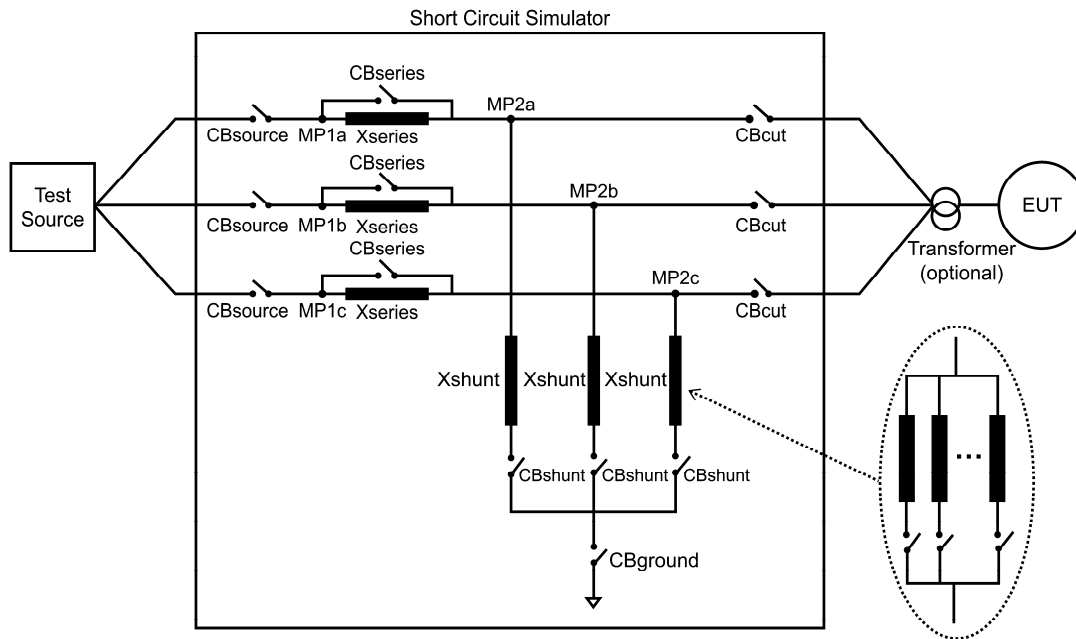

Figure G.1—Test setup for short-circuit simulator using voltage divider principle

G.2 Procedure

During normal condition operation the series reactance X_{series} is bypassed by circuit breaker CB_{series} and circuit breaker CB_{shunt} is open. During abnormal condition operation, CB_{series} is open, and then CB_{shunt} is closed to produce the voltage sag either for an asymmetric disturbance or a symmetric three-phase disturbance depending on how it is configured. In cases where multiple voltage sags with different magnitudes and durations are to be induced sequentially to create a voltage profile over time, the shunt and series impedance branches may be implemented using variable reactances or multiple parallel elements operated individually.

G.2.1 Procedure for LVRT test for line-to-ground voltage disturbance

The procedure is as follows:

- a) Select series reactor and short-circuit choke impedances to yield required line-to-ground voltage sag.
- b) Record impedance values and their X/R ratios.
- c) Configure CBsource, CBeut, and CBseries for gang operation.
- d) Configure CBshunt for either three-phase or two-phase or single-phase line-to-ground voltage disturbance depending on test case.
- e) Confirm that CBsource and CBseries are closed, and CBeut and CBshunt are open.
- f) Connect EUT to short-circuit simulator according to manufacturer's instruction using default settings.
- g) Close CBeut.
- h) Set EUT output power to target power level.
- i) Measure voltage at MP1 and record value.
- j) Open CBseries and wait until voltage returns to steady state conditions.
- k) Close CBground.
- l) Close CBshunt to induce voltage sag.
- m) Measure voltage at MP2 and record value. Verify that the voltage sag is below required value for any full fundamental frequency cycle during the test inclusive of any momentary secession.
- n) Open CBshunt after the required ride-through time terminating voltage sag.
- o) Close CBseries.
- p) Record whether the EUT completed the ride-through for required voltage sag and duration.

G.2.2 Procedure for LVRT test for line-to-line voltage disturbance

The procedure is as follows:

- a) Select series reactor and short-circuit choke impedances to yield required line-to-line voltage sag.
- b) Record impedance values and their X/R ratios.
- c) Configure CBsource, CBeut, and CBseries for gang operation.
- d) Configure CBshunt for either three-phase or two-phase line-to-line voltage disturbance depending on test case.
- e) Confirm that CBsource and CBseries are closed, and CBeut, CBshunt and CBground are open.
- f) Connect ETU to short-circuit simulator according to manufacturer's instructions using default settings.
- g) Close CBeut.
- h) Set EUT output power to target power level.
- i) Measure voltage at MP1 and record value.
- j) Open CBseries and wait until voltage returns to steady state conditions.
- k) Close CBshunt to induce voltage sag.

- l) Measure voltage at MP2 and record value. Verify that the voltage sag was below required value for any full fundamental frequency cycle during the test inclusive of any momentary secession.
- m) Open CBshunt after the required ride-through time terminating voltage sag.
- n) Close CBseries.
- o) Record whether the EUT completed the ride-through for required voltage sag and duration.

G.3 Requirements

The impedances employed in the short-circuit simulator shall have an X/R ratio of at least 3.¹⁶⁹

G.4 Criteria

The EUT may be considered in compliance if it does not trip and any active power oscillations are positively damped.

To account for the inevitable voltage transients induced by switching impedances in and out, an added 0.05 p.u. voltage tolerance above the required voltage profile shall be allowed. Average voltage during the period needs to be at or below the retained voltage during the excursion durations.

The EUT may be permitted to momentarily cease to energize the *area EPS* for the duration specified in 6.5.2.6 of IEEE Std 1547-2018. If it does, it shall be considered in compliance if and only if it returns to service following the criteria specified in 6.4.2.7 in IEEE Std 1547-2018.

G.5 Comments

The stiffness of the test source relative to the DER rating is an important factor in the ability of the short-circuit simulator to maintain a steady voltage during a voltage sag disturbance. It is recommended that the short-circuit power at the EUT (with or without transformer) be at least 3 times the EUT rated power. A short-circuit power lower than 3 times the EUT rated power could be used, if the EUT remains stable at these levels. For larger DER, a larger short-circuit power may be required. The calculation for apparent short-circuit power (S_{sc}) at the EUT is given below:

$$S_{sc} = V_{source}^2 / (X_{source} + X_{series})$$

where:

- V_{source} is the test source voltage (line-to-line)
- X_{source} is the test source impedance
- X_{series} is the impedance in series (see [Figure G.1](#))

¹⁶⁹Additional guidance on test equipment selection and setup may be found in IEC 62910.

Annex H

(informative)

Testing using a source other than a programmable ac power supply

H.1 Testing using a source other than a programmable ac power supply

If the source to be used for the fault-current characterization is not a programmable ac power supply, then the test apparatus for a three-phase EUT shall be as shown in Figure H.1. For this apparatus, the location 2-2 shown at the right of the figure is equivalent to location a-a in Figure 16.

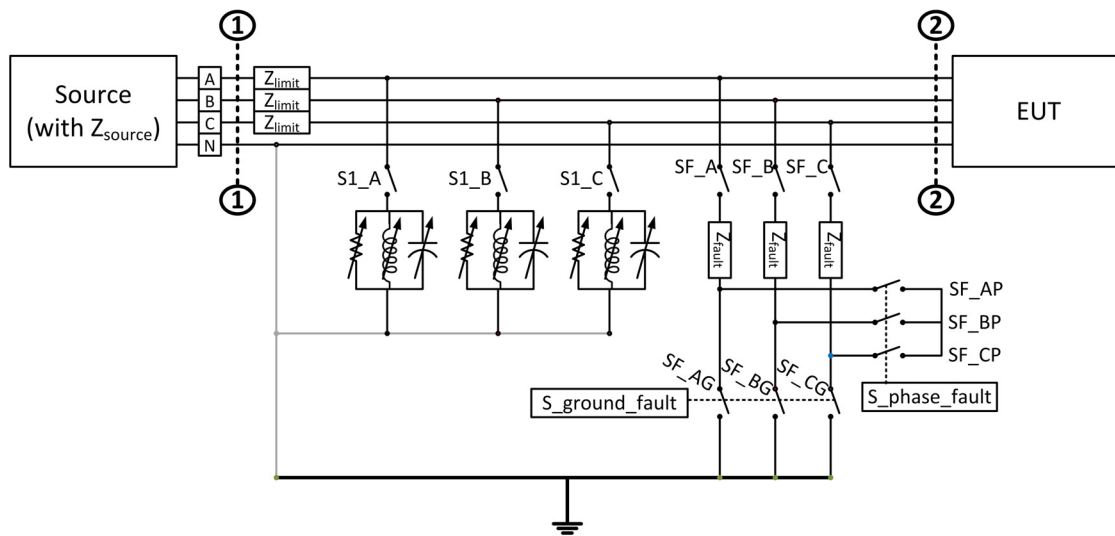

Figure H.1—Test apparatus for measuring fault current response of an EUT when using the area EPS

For the ac source, the complex positive, negative and zero-sequence impedances and the source voltage shall be provided with the test data. The data for the ac source shall be provided for all components on the source side of location 1 on the drawing.

The source must have a 3LG fault VA duty of at least three times the rating of the EUT and a 1LG fault VA duty of at least one times the rating of the EUT, as measured at location 1. The source impedance is considered to be part of the source and is to the left of location 1. The series impedance Z_{limit} and the shunt impedance Z_{fault} are part of the test apparatus, are adjustable, and may be resistive and/or inductive. The X/R ratio of the source impedance as seen from the EUT terminals shall be between 2.5 and 3.5.

The primary purpose of the RLC load included in this test circuit is to avoid an excessive voltage rise that may occur if the EUT were exporting significant power through Z_{limit} . If the voltage rise that occurs at Location 1 when the full EUT output flows back to the source is less than 5% of the nominal value at that point, then the RLC load may be omitted. When used, the resistive part of the RLC load shall be tuned to absorb $100\% \pm 1\%$ of the EUT output power, and the inductor or the capacitor shall be tuned to provide or absorb the EUT's reactive power as the EUT is tested using the unity power factor. It is not the intention

that the circuit include a resonant RLC tank; for most tests, either the L or the C will be necessary, but not both at the same time.

During phase-ground fault testing, the apparatus shall be configured so that the following conditions are met:

- The faulted phase-ground voltage(s) at location 2 in [Figure H.1](#) is less than 5% of the nominal voltage at that point.
- The unfaulted phase-ground voltage(s) at Location 2 remain between 90% and 138% of the nominal voltage at that point.
- The line-ground voltage at Location 1 in [Figure H.1](#) changes from its pre-fault value by no more than 5%.
- The frequency of the voltage at Location 1 in [Figure H.1](#), averaged over any ten-cycle window, shall remain between 59.0 Hz and 61.0 Hz throughout the test.

Similarly, during phase-phase fault testing, the apparatus shall be configured so that the following conditions are met:

- The line-line voltage between two faulted phases at Location 2 in [Figure H.1](#) is less than 5% of its nominal value.
- The unfaulted phase-phase voltages remain between 95% and 105% of their nominal voltages, and the unfaulted phase-ground voltages remain between 90% and 138% of their nominal values.
- The line-line voltage at location 1 in [Figure H.1](#) changes from its nominal value by no more than 5%.
- The frequency of the voltage at Location 1 in [Figure H.1](#), averaged over any ten-cycle window, shall remain between 59.0 Hz and 61.0 Hz throughout the test

If the EUT is a single-phase inverter, [Figure H.1](#) shall be interpreted on a per-phase basis: that is, the EUT shall be tested on any one phase, and the other two phases may be omitted.

If the *area EPS* is being used as the Source for this test and that *area EPS* can support application of a direct fault for purposes of this test, then the impedances Z_{limit} may be omitted. In this case, the requirements for the voltage at Location 2 given above shall apply. The requirements given above for the frequency of the voltage at Location 1 shall apply to the source frequency.

Annex I

(informative)

Closed-loop and open-loop time responses

A DER has some influence over the test voltage of the ac source to which the DER is attached. This influence can be modeled as a series impedance between an ideal ac voltage source and the DER. [Figure I.1](#) illustrates this circuit. The impedance, Z , represents the total impedance seen from the DER terminals, including the *ac test source* impedance and the impedance between the test source and the DER.

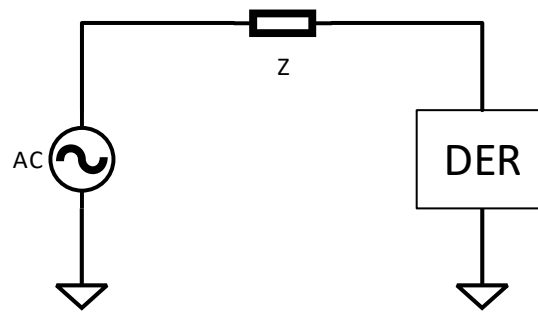

Figure I.1—DER connected to an ac source through a complex impedance

As the DER injects increasing current, the voltage change across the impedance, Z , increases. The voltage at the terminals of the DER is the sum of the voltage change across the series impedance and the voltage of the ideal ac voltage source. Thus, for a purely real impedance, as DER output current increases, the voltage at the terminals of the DER increases.

When a voltage regulation function is enabled, the DER may measure the voltage at its terminals and modulate its current accordingly. This forms a closed-loop system with voltage at the terminals of the DER providing a feedback loop. The closed-loop system formed with volt-var control enabled is shown in [Figure I.2](#).

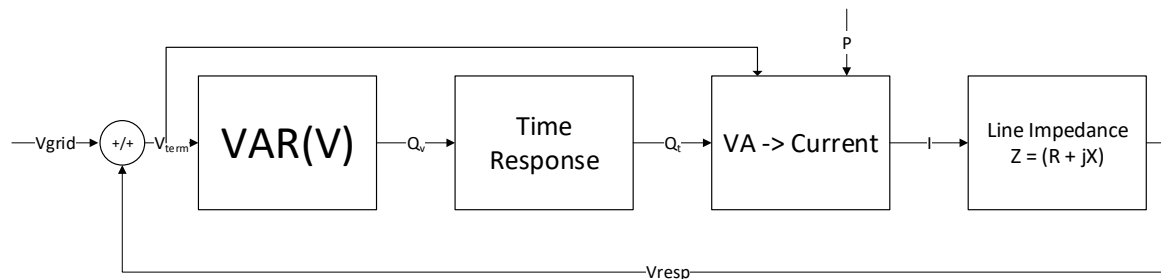

Figure I.2—System diagram of a DER with volt-var enabled

Table I.1—System variables from Figure I.2

Variable	Type	Description
V_{grid}	Complex Phasor	Voltage at the feeder without DER injection
V_{term}	Complex Phasor	Voltage at the terminals of the DER
Q_v	Real Value	Reactive power based on the voltage and volt-var characteristic
Q_t	Real Value	Reactive power based on the volt-var time response setting
P	Real Value	Active power being delivered to the grid
I	Complex Value	Current being delivered to the grid
Z	Complex Value	Impedance of the feeder to the DER

Table I.2—System equations from Figure I.2

Function	Time domain	Frequency domain	Description
VAR/V	$Q_v(V_{term})$	$Q_v(V_{term})$	Volt-var characteristic
Time Response	$1 - e^{-\alpha t}$	$\frac{\alpha}{s + \alpha}$	Time response of volt-var where $\alpha = \frac{-\ln 0.1}{T_r}$ (assumes time domain response can be approximated as a first-order response with time constant T_r).
VA -> Current	$I = \left(\frac{S}{V_{term}}\right)^* = \frac{[P + jQ_t]^*}{V_{term}^*}$	$I = \left(\frac{S}{V_{term}}\right)^* = \frac{[P + jQ_t]^*}{V_{term}^*}$	$Q(V, t)$ is the reactive power contribution from the volt-var function. This neglects other converter dynamics
Line Impedance	$Z = R + jX$	$R + jX$	Equivalent impedance seen by DER

The nonlinear nature of this system makes an analytical closed-form solution complicated to derive. An iterative solution may be used to find the closed-looped time response. The implicit equation to solve for V_{term} is shown below:

$$V_{term} = V_{grid} + \frac{[P + jVAR(|V_{term}|) \frac{\alpha}{s + \alpha}]^*}{V_{term}^*} \times Z$$

For line impedances with a large X/R ratios and where power is held constant, active and reactive power can be decoupled as the real portion of the line has little influence on the overall voltage. The impedance can also be normalized around nominal voltage to give a small signal impedance. The simplified system is shown in Figure I.3.

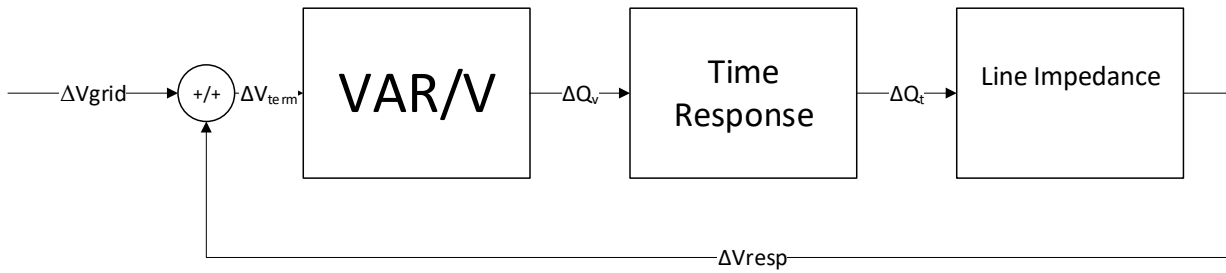

Figure I.3— Simplified system diagram of a DER with volt-var enabled

Table I.3—System equations from Figure I.3

Variable	Type	Description
ΔV_{grid}	Complex Phasor	Voltage at the feeder without DER injection, linearized around operating voltage
ΔV_{term}	Complex Phasor	Voltage at the terminals of the DER, linearized around operating voltage
ΔQ_v	Real Value	Reactive power based on the voltage and volt-var characteristic, linearized around operating voltage
ΔQ_t	Real Value	Reactive power based on the volt-var time response setting, linearized around operating voltage
$\frac{\Delta Z}{V_{nom}}$	Real Value	Impedance of the feeder to the DER, normalized by nominal grid voltage

Table I.4—System equations from Figure I.3

Function	Time domain	Frequency domain	Description
VAR/V	$\frac{\Delta Q_v}{\Delta V_{term}}$	$\frac{\Delta Q_v}{\Delta V_{term}}$	Slope from volt-var characteristic
Time Response	$1 - e^{-\alpha t}$	$\frac{\alpha}{s + \alpha}$	Time response of volt-var where $\alpha = \frac{-\ln 0.1}{T_r}$ (assumes time domain response can be approximated as a first-order response with time constant T_r)
Line Impedance	$\frac{\Delta Z}{V_{nom}}$	$\frac{\Delta Z}{V_{nom}}$	Small signal impedance normalized by nominal grid voltage, V_{nom}

With these simplified equations, the closed form solution for the voltage at the terminals of the DER is derived:

$$\Delta V_{term} = \Delta V_{grid} + \Delta V_{resp}$$

$$\Delta V_{resp} = \Delta V_{term} \times \frac{\Delta Q_v}{\Delta V_{term}} \times \frac{\alpha}{s + \alpha} \times \frac{\Delta Z}{V_{nom}}$$

$$\frac{V_{term}}{V_{zero\ var}} = \frac{s + \alpha}{s + \alpha \left(1 - \frac{\Delta Q_v}{\Delta V_{term}} \times \frac{\Delta Z}{V_{nom}} \right)}$$

Both the implicit equation and the closed-form explicit equation can be used to solve the closed-loop response of the system from the open-loop response of the system. The volt-var regulation function is used in this example, but this analysis can be used for other voltage regulation functions.

The closed-loop response may be used where stiff *ac test sources* are not available, for example due to large DER size or cable distance between the DER and the test source. A stiff *ac test source* is present when the series impedance in [Figure I.1](#) is very low, and the DER has little influence over its terminal voltage. Using a stiff *ac test source* and using the open loop response in the criteria is the preferred method for testing voltage regulation functions. The closed-loop response may be used with agreement from the DER manufacturer and *testing agency*.

Annex J

(informative)

Bibliography

Bibliographical references are resources that provide additional or helpful material but do not need to be understood or used to implement this standard. Reference to these resources is made for informational use only. All standards and specifications are subject to revision, and parties to agreements based on this standard are encouraged to investigate the possibility of applying the most recent editions of the references listed below.

[B1] ANSI C84.1, American National Standard for Electric Power Systems and Equipment—Voltage Ratings (60 Hz).

[B2] Cespedes, M. and Sun, J., “Three-phase impedance measurement for system stability analysis,” 2013 IEEE 14th Workshop on Control and Modeling for Power Electronics (COMPEL), Salt Lake City, UT, 2013, pp. 1–6.

[B3] Familiant, Yakov. A., Huang, Jing, Corzine, Keith A., and Belkhat, Mohammed. “New Techniques for Measuring Impedance Characteristics of Three-Phase AC Power Systems,” IEEE Transactions on Power Electronics, vol. 24, no. 7, pp. 1802–1810, July 2009.

[B4] Francis, Gerald. *An Algorithm and System for Measuring Impedance in D-Q Coordinates*, dissertation, Virginia Polytechnic Institute and State University, Blacksburg, VA, 2010.

[B5] IEC TR 61000-3-7, Electromagnetic compatibility (EMC)—Part 3-7: Limits—Assessment of emission limits for the connection of fluctuating installations to MV, HV and EHV power systems.¹⁷⁰

[B6] IEC 61000-4-15, Electromagnetic Compatibility (EMC)—Part 4: Testing and Measurement Techniques—Section 15: Flickermeter—Functional and Design Specifications.

[B7] IEC 61400-21, Wind Turbine Generator Systems—Part 21: Measurement and Assessment of Power Quality Characteristics of Grid Connected Wind Turbines.

[B8] IEC 62116, Utility-interconnected photovoltaic inverters—Test procedure of islanding prevention measures.

[B9] IEEE P1547.2TM, Draft Application Guide for IEEE Std 1547, Standard for Interconnection and Interoperability of Distributed Energy Resources with Associated Electric Power Systems Interfaces.^{171, 172}

[B10] IEEE P1547.9TM, Draft Guide to Using IEEE Standard 1547 for Interconnection of Energy Storage Distributed Energy Resources with Electric Power Systems.

[B11] IEEE Std C37.102TM, IEEE Guide for AC Generator Protection.¹⁷³

[B12] IEEE Std C37.106TM, IEEE Guide for Abnormal Frequency Protection for Power Generating Plants.

[B13] IEEE Std C37.108TM, IEEE Guide for the Protection of Network Transformers.

[B14] IEEE Std C50.12, IEEE Standard for Salient-Pole 50 Hz and 60 Hz Synchronous Generators and Generator/Motors for Hydraulic Turbine Applications Rated 5 MVA and Above.

¹⁷⁰IEC publications are available from the International Electrotechnical Commission (<http://www.iec.ch/>). IEC publications are also available in the United States from the American National Standards Institute (<http://www.ansi.org>).

¹⁷¹Numbers preceded by P are IEEE authorized standards projects that were not approved by the IEEE SA Standards Board at the time this publication went to press. For information about obtaining a draft, contact the IEEE.

¹⁷²The IEEE standards or products referred to in this annex are trademarks of The Institute of Electrical and Electronics Engineers, Inc.

¹⁷³IEEE publications are available from The Institute of Electrical and Electronics Engineers (<http://standards.ieee.org/>).

- [B15] IEEE Std C50.13, IEEE Standard for Cylindrical-Rotor 50 Hz and 60 Hz Synchronous Generators Rated 10 MVA and Above.
- [B16] IEEE Std C57.12.44TM, IEEE Standard Requirements for Secondary Network Protectors.
- [B17] IEEE Std 120TM, IEEE Master Test Guide for Electrical Measurements in Power Circuits.
- [B18] IEEE Std 519TM, IEEE Recommended Practices and Requirements for Harmonic Control in Electrical Power Systems.
- [B19] IEEE Std 1001TM, IEEE Guide for Interfacing Dispersed Storage and Generation Facilities with Electric Utility Systems.
- [B20] IEEE Std 1453TM, IEEE Recommended Practice for the Analysis of Fluctuating Installations on Power Systems.
- [B21] IEEE Std 1547.3TM, IEEE Guide for Monitoring, Information Exchange, and Control of Distributed Resources Interconnected with Electric Power Systems.
- [B22] IEEE Std 1547.4TM, IEEE Guide for Design, Operation, and Integration of Distributed Resource Island Systems with Electric Power Systems.
- [B23] IEEE Std 1547.5TM, IEEE Technical Guidelines for Interconnection of Electric Power Sources Greater Than 10 MVA to the Power Transmission Grid.
- [B24] IEEE Std 1547.6TM, IEEE Recommended Practice for Interconnecting Distributed Resources with Electric Power Systems Distribution Secondary Networks.
- [B25] IEEE Std 1547.7-2013, IEEE Guide for Conducting Distribution Impact Studies for Distributed Resource Interconnection.
- [B26] Lauss, G. F., M. O. Faruque, K. Schoder, C. Dufour, A. Viehweider, and J. Langston, "Characteristics and Design of Power Hardware-in-the-Loop Simulations for Electrical Power Systems," *IEEE Transactions on Industrial Electronics*, vol. 63, no. 1, pp. 406–417, Jan. 2016. doi: 10.1109/TIE.2015.2464308.
- [B27] Lundstrom, B., B. Mather, M. Shirazi, and M. Coddington, "Implementation and validation of advanced unintentional islanding testing using power hardware-in-the-loop (PHIL) simulation," *Photovoltaic Specialists Conference (PVSC), 2013 IEEE 39th*, pp. 3141–3146, 2013.
- [B28] UL 1741, Static Inverters and Charge Controllers for Use in Photovoltaic Power Systems.¹⁷⁴

¹⁷⁴UL standards are available from Global Engineering Documents (<http://global.ihs.com/>).

NATIONAL ANNEX K

*(National Foreword)**(Normative)*

K-1 This standard specifies the frequency as 60Hz for standard testing condition. However, as per Indian conditions, the frequency shall be considered as 50Hz.

K-2 (Page 66, Table 15) — Substitute the following for the existing:

Table 15 Voltage and Frequency Trip Settings for Unintentional Islanding Testing
(Clause 5.10.2.1)

SI No. (1)	Trip Function (2)	Category I and Category II		Category III	
		Voltage (P.U.) (3)	Clearing Time (S) (4)	Voltage (P.U.) (5)	Clearing Time (S) (6)
i)	OV2	1.2	0.16	1.2	0.16
ii)	OV1	1.2	13	1.2	13
iii)	UV1	0	21	0	50
iv)	UV2	0	2	0	21
		Frequency (Hz)	Clearing time (s)	Frequency (Hz)	Clearing time (s)
vi)	OF2	52	1000	52	1000
vii)	OF1	52	1000	52	1000
viii)	UF1	47.5	1000	47.5	1000
ix)	UF2	47.5	1000	47.5	1000

K-3 (Page 111, Table 38) — Insert the following note at the end:

'NOTE — Indian frequency of 50 Hz and proportional frequencies can be referred for Table 38.'

K-4 (Page 111, Table 39) — Insert the following note at the end:

'NOTE — Indian frequency of 50 Hz and proportional frequencies can be referred for Table 39.'

Bureau of Indian Standards

BIS is a statutory institution established under the *Bureau of Indian Standards Act, 2016* to promote harmonious development of the activities of standardization, marking and quality certification of goods and attending to connected matters in the country.

Copyright

Subject to BIS copyright interest in the country specific changes, copyright in this standard is held by IEEE. No part of these publications may be reproduced in any form without the prior written permission of the copyright owner. This does not preclude the free use, in course of implementing the standard, of necessary details, such as symbols and sizes, type or grade designations. Inquiries relating to copyright be addressed to the Director (Publications), BIS.

Review of Indian Standards

Amendments are issued to standards as the need arises on the basis of comments. Standards are also reviewed periodically; a standard along with amendments is reaffirmed when such review indicates that no changes are needed; if the review indicates that changes are needed, it is taken up for revision. Users of Indian Standards should ascertain that they are in possession of the latest amendments or edition by referring to the website- www.bis.gov.in or www.standardsbis.in.

This Indian Standard has been developed from Doc No.: ETD 46 (25622).

Amendments Issued Since Publication

Amend No.	Date of Issue	Text Affected

BUREAU OF INDIAN STANDARDS

Headquarters:

Manak Bhavan, 9 Bahadur Shah Zafar Marg, New Delhi 110002

Telephones: 2323 0131, 2323 3375, 2323 9402

Website: www.bis.gov.in

Regional Offices:

Central : 601/A, Konnectus Tower -1, 6th Floor,
DMRC Building, Bhavbhuti Marg, New
Delhi 110002

Telephones

{ 2323 7617

Eastern : 8th Floor, Plot No 7/7 & 7/8, CP Block, Sector V,
Salt Lake, Kolkata, West Bengal 700091

{ 2367 0012
{ 2320 9474

Northern : Plot No. 4-A, Sector 27-B, Madhya Marg,
Chandigarh 160019

{ 265 9930

Southern : C.I.T. Campus, IV Cross Road, Taramani, Chennai 600113

{ 2254 1442
{ 2254 1216

Western : 5th Floor/MTNL CETTM, Technology Street, Hiranandani Gardens, Powai
Mumbai 400076

{ 25700030
{ 25702715

Branches : AHMEDABAD, BENGALURU, BHOPAL, BHUBANESHWAR, CHANDIGARH, CHENNAI, COIMBATORE, DEHRADUN, DELHI, FARIDABAD, GHAZIABAD, GUWAHATI, HARYANA (CHANDIGARH), HUBLI, HYDERABAD, JAIPUR, JAMMU, JAMSHEDPUR, KOCHI, KOLKATA, LUCKNOW, MADURAI, MUMBAI, NAGPUR, NOIDA, PARWANOO, PATNA, PUNE, RAIPUR, RAJKOT, SURAT, VIJAYAWADA.