

मशीनरी की सुरक्षा — इलेक्ट्रो-सेंसिटिव
रक्षात्मक उपकरण

भाग 4 विज्ञान आधारित रक्षात्मक डिवाइसेस का
उपयोग करने वाले उपकरणों के लिए विशेष
आवश्यकताएं (वीबीपीडी)

अनुभाग 2 सदंर्भ पैटर्न तकनीक का उपयोग करते समय
अतिरिक्त आवश्यकताएं (वीबीपीडीपीपी)
(पहला पुनरीक्षण)

**Safety of Machinery —
Electro-Sensitive Protective
Equipment**

**Part 5 Particular Requirements for
Equipment Using Vision Based
Protective Devices (VBPD)**

**Section 2 Additional Requirements When Using
Reference Pattern Techniques (VBPDP)**

(*First Revision*)

ICS 13.110; 29.260.99

© BIS 2024

© IEC 2022



भारतीय मानक ब्यूरो

BUREAU OF INDIAN STANDARDS

मानक भवन, 9 बहादुर शाह ज़फर मार्ग, नई दिल्ली - 110002

MANAK BHAVAN, 9 BAHADUR SHAH ZAFAR MARG

NEW DELHI - 110002

www.bis.gov.in

www.standardsbis.in

NATIONAL FOREWORD

This Indian Standard (First Revision) which is identical to IEC TS 61496-4-2 : 2022 'Safety of machinery — Electro sensitive protective equipment — Part 4-2: Particular requirements for equipment using vision based protective devices (VBPD) — Additional requirements when using reference pattern techniques (VBPDP)' issued by the International Electrotechnical commission (IEC) was adopted by the Bureau of Indian Standards on the recommendation of the Safety of Machinery - Electrotechnical Aspects Sectional Committee and approval of the Electrotechnical Division Council.

This standard was first published in 2021 identical to IEC 61496-4-2 : 2014. This revision has been undertaken to align this standard with the latest version of IEC 61496-4-2.

The text of the IEC standard has been approved as suitable for publication as an Indian Standard without deviations. Certain conventions are, however, not identical to those used in Indian Standards. Attention is particularly drawn to the following:

- a) Wherever the words 'International Standard' appears referring to this standard, they should be read as 'Indian Standard'; and
- b) Comma (,) has been used as a decimal marker, while in Indian Standards the current practice is to use a point (.) as the decimal marker.

In this adopted standard, reference appears to International Standards for which Indian Standards also exists. The corresponding Indian Standards, which are to be substituted, are listed below along with their degree of equivalence for the editions indicated:

<i>International Standard</i>	<i>Corresponding Indian Standard</i>	<i>Degree of Equivalence</i>
IEC 61496-1 : 2020 Safety of machinery — Electro-sensitive protective equipment — Part 1: General requirements and tests	IS 16502 (Part 1) : 2023/ IEC 61496-1 : 2020 Safety of machinery — Electro-sensitive protective equipment: Part 1 General requirements and tests	Identical
IEC 62471 : 2006 Photobiological safety of lamps and lamp systems	IS 16108 : 2012/IEC 62471 : 2006 Photobiological safety of lamps and lamp systems	Identical
ISO 13855 : 2010 Safety of machinery — Positioning of safeguards with respect to the approach speeds of parts of the human body	IS 16815 : 2019/ISO 13855 : 2010 Safety of machinery — Positioning of safeguards with respect to the approach speeds of parts of the human body	Identical
ISO 20471 High-visibility clothing — Test methods and requirements	IS 15809 : 2017 High visibility warning clothes — Specification (<i>first revision</i>)	Technically equivalent

[*\(Continued on third cover\)*](#)

CONTENTS

INTRODUCTION.....	iv
1 Scope.....	1
2 Normative references	2
3 Terms and definitions	2
4 Functional, design and environmental requirements	4
5 Testing	12
6 Marking for identification and for safe use	21
7 Accompanying documents	22
Annex A (normative) Optional functions of the ESPE	23
Annex B (normative) Catalogue of single faults affecting the electrical equipment of the ESPE, to be applied as specified in 5.3.....	25
Annex AA (informative) The positioning of VBPD in respect of parts of the human body	26
Bibliography.....	33
Figure 1 – Image planes in VBPDPP.....	4
Figure 2 – Side view of VBPDPP using a passive reference pattern.....	5
Figure 3 – Light intensity measurement setup for indirect light tests.....	18
Figure 4 – Light intensity measurement setup for direct light tests	19
Figure AA.1 – Minimum distance S – Example 1.....	29
Figure AA.2 – Overall minimum distance S_0 without tolerance zone – Example 1	29
Figure AA.3 – Overall minimum distance S_0 including tolerance zone – Example 1	30
Figure AA.4 – Minimum distance S – Example 2.....	31
Figure AA.5 – Overall minimum distance S_0 without tolerance zone – Example 2.....	32
Figure AA.6 – Overall minimum distance S_0 including tolerance zone – Example 2	32
Table 421 – Verification of detection capability requirements (see also 4.2.12).....	13
Table 422 – Overview of light interference tests.....	16

INTRODUCTION

An electro-sensitive protective equipment (ESPE) is applied to machinery presenting a risk of personal injury. It provides protection by causing the machine to revert to a safe condition before a person can be placed in a hazardous situation.

The working group responsible for drafting this document was concerned that, due to the complexity of the technology, there are many issues that are highly dependent on analysis and expertise in specific test and measurement techniques. In order to provide a high level of confidence, independent review by relevant expertise is recommended. They considered that if this high level of confidence could not be established these devices would not be suitable for use in safety related applications.

Indian Standard

SAFETY OF MACHINERY — ELECTRO-SENSITIVE PROTECTIVE EQUIPMENT

PART 5 PARTICULAR REQUIREMENTS FOR EQUIPMENT USING VISION BASED PROTECTIVE DEVICES (VBPD)

SECTION 2 ADDITIONAL REQUIREMENTS WHEN USING REFERENCE PATTERN TECHNIQUES (VBPDP)

(First Revision)

1 Scope

Replacement:

This document specifies requirements for the design, construction and testing of non-contact electro-sensitive protective equipment (ESPE) designed specifically to detect persons as part of a safety-related system, employing vision-based protective devices (VBPDs) using reference pattern techniques (VBPDP) for the sensing function. Special attention is directed to features which ensure that an appropriate safety-related performance is achieved. An ESPE can include optional safety-related functions, the requirements for which are given in Annex A of IEC 61496-1:2020 and this document.

NOTE "Non-contact" means that physical contact is not required for sensing.

Where this document does not contain all necessary provisions, then IEC TS 62998-1 applies.

It is also possible, for those aspects not considered in this document, to use provisions from IEC TS 62998-1 additionally.

This document does not specify the dimensions or configurations of the detection zone and its disposition in relation to hazardous parts for any particular application, nor what constitutes a hazardous state of any machine. It is restricted to the functioning of the ESPE and how it interfaces with the machine.

A VBPDP is defined as consisting of a single image-sensing device viewing on a passive reference pattern as the background and where the detection principle is based on blocking or partially preventing the view of the pattern. Information about the thickness, shape, surface characteristics or location of the object is not required for detection. For multi-image sensing devices, additional techniques, requirements and test procedures can be necessary.

- This document is limited to automatic vision-based ESPEs that do not require human intervention for detection.
- It is limited to automatic vision-based ESPEs that detect objects entering into, or are present in, a detection zone(s).
- It is limited to ESPEs using active illumination technique.
- Excluded from this technical specification are VBPDPs employing radiation at wavelengths outside the range 400 nm to 1 500 nm.
- This document does not address those aspects required for complex classification or differentiation of the object detected.

This document is relevant for VBPDPs having a stated detection capability up to 200 mm.

NOTE The positioning of VBPD in respect of parts of the human body is presented in Annex AA of this document.

This document does not deal with EMC emission requirements.

2 Normative references

Addition:

IEC 60825-1:2014, *Safety of laser products – Part 1: Equipment classification and requirements*

IEC 61496-1:2020, *Safety of machinery – Electro-sensitive protective equipment – Part 1: General requirements and tests*

IEC 62471:2006, *Photobiological safety of lamps and lamp systems*

ISO 13855:2010, *Safety of machinery – Positioning of safeguards with respect to the approach speeds of parts of the human body*

ISO 20471, *High-visibility clothing – Test methods and requirements*

3 Terms and definitions

This clause of IEC 61496-1:2020 is applicable except as follows:

Replacement:

3.3

detection capability

ability to detect the specified test pieces (see 4.2.13) in the specified detection zone

Note 1 to entry: Detection capability is generally measured by the size of object that can be detected. An increase in detection capability means that a smaller object can be detected.

[SOURCE: IEC 61496-1:2020, 3.3, modified – The text has been changed to make it more relevant to vision based sensors and Note 1 has been added]

Additions:

3.4201

image

snapshot representation of the scene in different planes of the VBPDPP in the form of a two dimensional matrix

3.4202

imaging sensor

optoelectronic device which produces electrical signals representing the characteristics of an image

3.4203

passive reference pattern

static (i.e. fixed location and not changing) regular (periodic) combination of pattern elements on a background that covers at least the detection zone and the tolerance zone – blocking the view of part of the pattern causes detection

Note 1 to entry: Regularity of the pattern refers only to the physical pattern and not to the image of the pattern as seen by the imaging sensor.

3.4204

pattern element

local part of the passive reference pattern

EXAMPLE Black and white checker board – one black square or one white square.

3.4205

pixel, <of a sensor>

smallest light sensitive element of an imaging sensor array

3.4206

pixel, <of an image>

area of the smallest element that can be distinguished from its neighbouring elements

3.4207

sensing zone

three-dimensional volume defined by the field of view of the image sensor and with the apex at the optical window of the sensing device

Note 1 to entry: The volume could be in the shape of a pyramid or cone.

Note 2 to entry: A zone of limited detection capability, a detection zone and tolerance zone(s) are contained within the sensing zone. The zone of limited detection capability is located between the optical window of the sensing device and the detection zone.

3.4208

tolerance zone

zone outside of and adjacent to the (configured) detection zone within which the specified test piece may not be detected

3.4209

vision-based protective device

VBPD

ESPE using an imaging sensor, operating in the visible and near infrared light spectrum to detect an object in a defined field of view

Note 1 to entry: This note applies to the French language only.

3.4210

vision-based protective device using passive reference pattern techniques

VBPDPP

VBPD using a single imaging device and active illumination viewing on a passive reference pattern as background

Note 1 to entry: The various parts of a VBPDPP and their relationship to the viewed scene is shown in Figure 1.

Note 2 to entry: This note applies to the French language only.

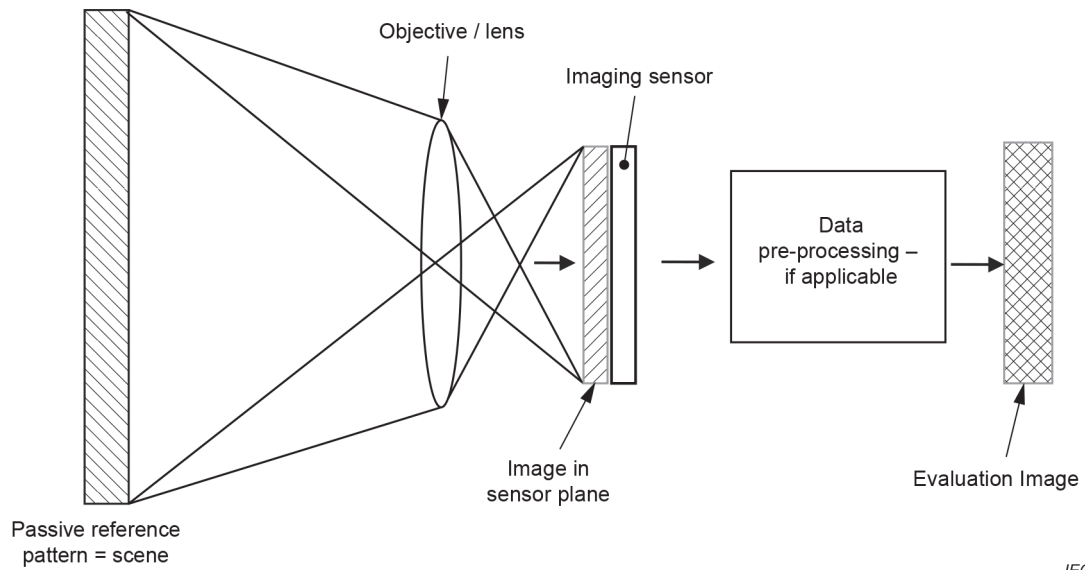

Figure 1 – Image planes in VBDPP

3.4211

zone with limited detection capability

volume between the detection zone and the optical window(s) of the sensing device which does not achieve the stated detection capability

Note 1 to entry: The dimensions and appropriate information for use of the zone with limited detection capability are provided by the supplier.

4 Functional, design and environmental requirements

This clause of IEC 61496-1:2020 is applicable except as follows:

4.1 Functional requirements

4.1.2 Sensing function

Replacement:

4.1.2.1 General

The detection zone shall begin at the border of the zone of limited detection capability and end at the passive reference pattern (see Figure 2).

NOTE It is possible that only parts of the passive reference pattern are used to define the detection zone.

Object(s) in the zone of limited detection capability shall not reduce the detection capability within the detection zone. Any reduction of the detection capability shall be detected and the VBDPP shall go to lock-out condition (see 4.2.2.4).

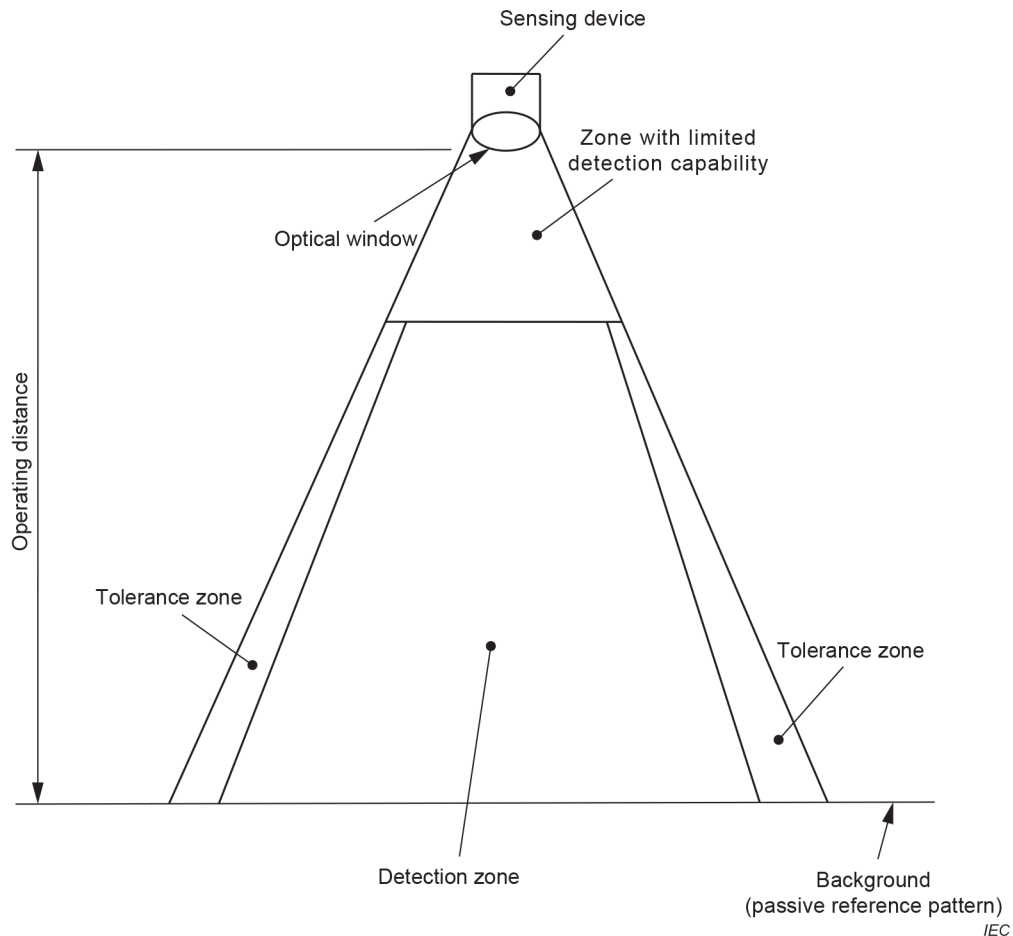

Figure 2 – Side view of VBPDP using a passive reference pattern

4.1.2.2 Additional functional requirements

The sensing function shall be effective over the specified detection zone. No adjustment of the detection zone or detection capability shall be possible without the use of a security measure (e.g. key, key-word or tool).

The sensing device of a VBPDP shall respond by giving (an) appropriate output signal(s) when a test piece is placed anywhere within the detection zone either static or moving.

The supplier shall specify the limits of detection capability. The supplier shall take into account worst case scenario including, for example, signal-to-noise ratio, light intensity in the image on the sensor plane, contrast in the image on the sensor plane, position of the image on the sensor, considering all influences listed in this document.

4.1.2.3 Optical performance

The VBPDP shall be designed and constructed to

- limit the possibility of malfunction during exposure to extraneous radiation in the range of 400 nm to 1 500 nm;
- limit the effects of environmental influences (temperature, vibration and bumps, dust, moisture, ambient light, extraneous reflections, changing illumination, shadows, background reflectivity);
- limit the misalignment at which normal operation is possible.

4.1.3 Types of ESPE

Replacement:

In this document, only a type 3 ESPE is considered. It is the responsibility of the machine supplier and/or the user to specify which type is required for a particular application.

The type 3 ESPE shall fulfil the fault detection requirements of 4.2.2.4 of this document. In normal operation, the output circuit of each of at least two output signal switching devices (OSSDs) shall go to the OFF-state when the sensing device is actuated, or when the power is removed from the ESPE.

When a single safety-related data interface is used to perform the functions of the OSSD(s), then the data interface and associated safety-related communication interface shall meet the requirements of 4.2.4.4 of IEC 61496-1:2020. In this case, a single safety-related data interface can substitute for two OSSDs in a type 3 ESPE.

Addition:

4.1.6 Zone with limited detection capability

A zone between the optical window and the beginning of the detection zone is referred to as a zone with limited detection capability. In order to ensure no hazard can arise in a particular application due to the presence of this zone between the optical window and the detection zone, its dimensions and appropriate information for use shall be provided by the supplier.

4.2 Design requirements

4.2.2 Fault detection requirements

4.2.2.2 Particular requirements for a type 1 ESPE

This subclause of IEC 61496-1:2020 is not applicable.

4.2.2.3 Particular requirements for a type 2 ESPE

This subclause of IEC 61496-1:2020 is not applicable.

4.2.2.4 Particular requirements for a type 3 ESPE

Addition:

NOTE Examples of deterioration of the VBPDP detection capability include:

- increase of the minimum detectable object size;
- Increase in the minimum detectable contrast.

4.2.2.5 Particular requirements for a type 4 ESPE

This subclause of IEC 61496-1:2020 is not applicable.

NOTE Type 4 is not considered in this document. Additional definitions, requirements and test procedures would be necessary.

4.2.12 Integrity of the ESPE detection capability

Replacement:

4.2.12.1 General

The design of the VBPDP shall ensure that the detection capability is not decreased below the limits specified by the supplier and in this document by any of, but not limited to, the following:

a) at the minimum contrast between an object and reference pattern on the evaluation images;

NOTE Minimum contrast on the evaluation image can be achieved by low or high contrast in the scene.

b) the position of the object within the detection zone

c) the number of objects;

d) the size of objects;

e) auto-adjustment, for example the following:

1) auto-focus

2) gain control

3) orientation

4) sample rate

5) shutter time

6) aperture stops

7) focal length

f) properties/limitations of imaging sensor, for example the following:

1) signal noise (e.g. fixed pattern noise; dark noise)

2) dynamic range

3) sensitivity

4) micro lenses

5) gain settings

6) cold and hot pixels

7) dark current

8) change of characteristics, e.g. wavelength dependent sensitivity, filter

9) photo response non-uniformity

g) accuracy of object position in images, accuracy and stability of calibration;

h) at the limits of alignment and/or adjustment;

i) ageing of components;

j) performance and limitations of the optical components;

k) component tolerances;

l) changing of internal and external references to guarantee the detection capability;

m) environmental conditions specified in 4.3.

If a single fault (as specified in Annex B of IEC 61496-1:2020), which under normal operating conditions (see 5.1.2.1 of IEC 61496-1:2020) would not result in a loss of VBPDP detection capability but, when occurring with a combination of the conditions specified above, would result in such a loss, that fault, together with that combination of conditions (as determined to be relevant during the analysis of the design) shall be considered as a single fault and the VBPDP shall respond to such a single fault as required in 4.2.2.4.

The VBPDPP shall not fail to danger if a reflective object (for example, reflective clothes) is placed at any position in the detection zone.

The relationship of the minimum detectable object size and the size of the elements of the passive reference pattern shall be sufficient to ensure the integrity of the detection capability (e.g. object size is three or more times the size of the pattern element).

4.2.12.2 Detection zone

The supplier shall specify the size, shape and other relevant parameters of the detection zone(s). The supplier shall define values in the range up to 200 mm as the minimum detectable object size of the VBPDPP. The minimum detectable object size may be distance dependent. All points on a path projected from any point on the border of the detection zone to the imaging sensor of the VBPDPP shall be within the detection zone or the zone with limited detection capability (see 4.1.6).

4.2.12.3 Response time

Objects of the minimum detectable size that are either stationary or moving within the detection zone at any speed up to 1,6 m/s shall be detected by the ESPE within the specified response time. The supplier shall specify the maximum response time. The supplier shall take into account worst case conditions including, for example, frame rate, evaluation time, minimum diameter of the test piece, maximum speed of the test piece and number of objects in the detection zone as well as environmental influences. Where the supplier states that a VBPDPP can be used to detect objects moving at speeds greater than 1,6 m/s, the requirements shall be met at any speed up to and including the stated maximum speed(s).

4.2.12.4 Tolerance zone(s)

Where a tolerance zone is necessary, the supplier shall specify the tolerance zone(s).

The supplier shall take into account worst-case conditions including for example, signal-to-noise ratio S/N.

NOTE The tolerance zone depends on optical performance, systematic interferences, pixel size, resolution, geometry of the pattern elements, etc.

4.2.12.5 Passive reference pattern(s) and object discrimination

The passive reference pattern is part of the VBPDPP. The design of the passive reference pattern shall be made in a way that discrimination of the object from the pattern can be achieved. The detection capability shall not be decreased below the limits specified by the supplier by any of, but not limited to the following influences:

- a) contrast between pattern elements;
- b) contrast changes within pattern elements;
- c) size of pattern elements and number of pattern elements used for object detection;
- d) size of pixels and numbers of pixels used for object detection;
- e) algorithm/routines used for object discrimination in front of passive reference pattern;
- f) automatic adaption of algorithm/routines;
- g) size, shape, colour, reflectivity, position and texture of object compared to passive reference pattern;
- h) resulting contrast between object and pattern elements on the imaging sensor.

4.2.13 Test piece

Replacement:

4.2.13.1 General

The test pieces shall be provided by the supplier for use in the type tests of Clause 5. They shall be marked with a type reference and identification of the VBPDPP with which they are intended to be used.

The test pieces shall be opaque.

The test pieces shall have a diameter equal to the maximum specified detection capability (minimum diameter).

Different test pieces can be required for different phases of the test procedures.

Characteristics of the test piece which shall be considered are:

- size;
- shape;
- colour;
- reflectivity;
- contrast with background;
- texture.

When defining the characteristics of the test piece, protection against camouflage (i.e. mimic the background appearance), with the passive reference pattern shall be taken into account. The reflectivity of the test piece shall be selected to create a worst-case condition for the passive reference pattern discriminators. As a minimum, the following surfaces shall be considered:

- a black surface with a coefficient of diffuse reflection of less than 5 % at the operating wavelength of the VBPDPP;
- a white surface with a coefficient of diffuse reflection of 80 % to 90 % at the operating wavelength of the VBPDPP;
- a retroreflective surface that complies with the requirements for separate performance retro-reflective material of ISO 20471 or equivalent.

Where other surface characteristics are shown to be critical as result of the analysis of the design, these characteristics shall be applied to the test piece. Test pieces of different reflectivity may be necessary.

4.2.13.2 Cylindrical test piece

The test piece shall be cylindrical for detection capabilities up to 40 mm. The test piece shall have a diameter equal to the maximum specified detection capability (minimum diameter) and a length selected for ease of use.

NOTE Depending on the diameter of the cylindrical test piece, it can represent fingers, hands or wrists.

4.2.13.3 Conical test piece

The test piece shall be a truncated cone in combination with a cylinder if the VBPDPP is intended to be used for arm detection. The test piece starts with a diameter of 40 mm increasing up to 55 mm as a cone over a length of 180 mm and continues as a cylinder with a diameter of 55 mm to an overall length of 440 mm.

The test piece shall be a truncated cone if the VBPDPP is intended to be used for leg detection. The test piece starts with a diameter of 50 mm increasing up to 117 mm over a length of 1 000 mm.

If the VBPDPP is intended to be used for detection of different parts of a body, the selection of the most appropriate test pieces shall be dependent on the analysis of the design and intended application. In some cases, all test pieces can be required.

4.2.13.4 Spherical test piece

If the VBPDPP is intended to be used for whole body detection, then the test piece shall be a sphere with a maximum diameter of 200 mm attached to a cylinder with a maximum diameter of 50 mm and a length selected for ease of use.

NOTE A spherical test piece with a diameter of 200 mm is intended to represent the thickness of a body.

Addition:

4.2.14 Wavelength

VBPDPPs shall operate at a wavelength within the range of 400 nm to 1 500 nm.

4.2.15 Radiation intensity

Where the VBPDPP is of the type that emits light and if the emitting element uses LED technology, the radiation intensity generated and emitted by the VBPDPP shall meet the requirements of exempt group in accordance to IEC 62471.

NOTE Exempt group is equal to risk group zero (IEC 62471).

Where the VBPDPP is of the type that emits light and if the emitting element uses laser technology, the radiation intensity generated and emitted by the VBPDPP shall at no time exceed the maximum power or energy levels for a class 1M device in accordance with 8.2 of IEC 60825-1:2014. The marking as class 1 or class 1M laser shall be carried out as required in 5.2 of IEC 60825-1:2014.

4.2.16 Mechanical construction

When the detection capability can be decreased below the limit stated by the supplier as a result of a change of position of its components, the fixing of those components shall not rely solely on friction.

NOTE The use of oblong mounting holes without additional means could lead for example to a change of the position of the detection zone under mechanical interference such as bump.

4.3 Environmental requirements

Addition:

4.3.6 Ambient light intensity

The VBPDPP shall continue in normal operation within a range of illumination on the passive reference pattern, from 100 lx to 1 500 lx. If the supplier specifies background characteristics with lower limits those shall be used. The tests shall be performed at those limits. Outside this range or these limits the VBPDPP shall not fail to danger.

4.3.7 Pollution interference

4.3.7.1 Effects on optical window

Pollution on the optical window shall not lead to a failure to danger.

Pollution resulting in a complete loss of the stated VBPDP detection capability shall cause the OSSDs to go to the OFF-state within the specified response time.

Pollution resulting in a deterioration of the stated VBPDP detection capability shall cause the OSSDs to go to the OFF-state within a time period of 5 s following the occurrence of the pollution interference.

4.3.7.2 Effects in the detection zone

Pollution within the detection zone or the zone with limited detection capability shall not lead to a failure to danger.

Pollution resulting in a complete loss of the stated VBPDP detection capability shall cause the OSSDs to go to the OFF-state within the specified response time.

Pollution resulting in a deterioration of the stated VBPDP detection capability shall cause the OSSDs to go to the OFF-state within a time period of 5 s following the occurrence of the pollution interference.

4.3.8 Changes of passive reference pattern

Changes of the passive reference pattern caused by, for example, fading, ageing, mechanical effects or contamination shall not lead to a failure to danger.

4.3.9 Manual interference

The following conditions shall not lead to a failure to danger:

- covering the optical window of the housing of the VBPDP or other parts (if applicable);
- placing objects within the zone of limited detection capability;
- moving the passive reference pattern (except if the pattern is required to be permanently fixed) in any direction.

If the manual interference would result in a failure to danger condition then the VBPDP shall respond by giving (an) appropriate output signal(s) within 5 s. The appropriate output signal(s) shall remain until the manual interference is removed.

4.3.10 Optical occlusion (eclipsed by small object)

The VBPDP detection capability shall be maintained if moving or static objects or parts of a machine which are smaller than the detection capability are in the detection zone or the zone with limited detection capability, which can block the view of the object which shall be detected. If the detection capability can not be maintained the OSSDs shall go to the OFF-state and shall remain in the OFF-state if the object is removed. This shall be verified by analysis and by a test according to 5.4.9.

NOTE Software filtering algorithms are sometimes provided to disregard small objects, for example, to increase the reliability of operation.

4.3.11 Drift or ageing of components

Drift or ageing of components that would reduce the detection capability below the stated value shall not cause a failure to danger of the ESPE, shall be detected within 5 s and shall lead to a lock-out condition.

If a reference object is used for monitoring ageing and drift of components, variations in the properties of the reference object (for example, reflectance) shall not cause a failure to danger of the ESPE. If a reference object is used to monitor ageing and drift of components, it shall be considered to be part of the VBPDP and shall be provided by the supplier of the VBPDP.

5 Testing

This clause of IEC 61496-1:2020 is applicable except as follows:

5.1 General

5.1.1 Type tests

5.1.1.1 Test samples

Addition:

As a result of the analysis of the design and optical performance of the VBPDP the test plan shall be established considering the test conditions and parameters outlined in this document.

The minimum test conditions shall be as specified in this document or by the supplier, whichever is more stringent. Unless otherwise stated, the tests shall be done with the minimum detection zone positioned as specified in Table 421.

In the following tests, it shall be verified that when the OSSDs go to the OFF-state, they remain in the OFF-state while the test piece is present in the detection zone.

5.2 Functional tests

5.2.1 Sensing function

Addition:

5.2.1.1 General

The sensing function and the integrity of the detection capability shall be tested as specified, taking into account the following:

- Tests shall be performed with the test piece close to the passive reference pattern, close to the zone of limited detection and close to the tolerance zone(s). Tests at other locations may be required depending on analysis of the design and worst-case considerations.
- All tests shall be performed with the test piece axis parallel to the passive reference pattern. Tests at other angles of inclinations may be required depending on analysis of the design and worst-case considerations.
- During the tests, the fixture holding the test piece should not be visible to the sensor (as much as practical).
- The tests shall verify that the specified test pieces are detected when the test piece is placed entirely inside the stated detection zone(s) as far as the stated detection capability.
- The tests shall verify that the specified test pieces are continuously detected when the test piece is moving into or within the detection zone at any speed from 0 m/s to 1,6 m/s. Where the supplier states that objects can be detected moving at higher speeds, the requirements shall be met at all speeds up to the stated maximum speeds.
- The number, selection and conditions of the individual tests shall be such as to verify the requirements of 4.2.12.

It shall be verified that the sensing device is continuously actuated and, where appropriate, that the OSSDs go to the OFF-state as described below, taking into account the operating principle of the VBPDP and, in particular, the techniques used to provide tolerance to environmental interference.

An overview of the minimum tests required for verification of the detection capability is shown in Table 421.

Table 421 – Verification of detection capability requirements (see also 4.2.12)

Sub-clause	Test related to	Conditions ^a	Maximum operating distance from sensing device to passive reference pattern		Minimum operating distance from sensing device to passive reference pattern ^b	
			Test piece at minimum detection distance ^c	Test piece on passive reference pattern ^c	Test piece at minimum detection distance ^c	Test piece on passive reference pattern ^c
5.2.1.1	Sensing function	Applicable test piece (see 4.2.13) Speed between 0 m/s and 1,6 m/s	X	X	X	X
5.2.1.3	Endurance Test	^d	See 5.2.1.3	See 5.2.1.3		
5.4.2 of IEC 61496-1:2020	Ambient temperature variation	50 °C or maximum ^e 5.4.2 of IEC 61496-1:2020 applies.				X
5.4.2 of IEC 61496-1:2020	Ambient temperature variation	0° or minimum, non-condensing ^f 5.4.2 of IEC 61496-1:2020 applies.				X
5.4.2 of IEC 61496-1:2020	Humidity	5.4.2 applies.				X
5.4.3 of IEC 61496-1:2020	Electrical disturbances	4.3.2, 5.2.3.1 and 5.4.3 of IEC 61496-1:2020 apply.				X
5.4.4.1	Vibration	5.4.4.1 applies				X
5.4.4.2	Shock	5.4.4.2 applies				X
5.4.6	Light interference	See Table 422				
5.4.7	Pollution on the surface of the optical window (4.3.7.1)		See 5.4.7	See 5.4.7	See 5.4.7	See 5.4.7
5.4.7	Pollution in the detection zone (4.3.7.2)		See 5.4.7	See 5.4.7	See 5.4.7	See 5.4.7
5.4.8	Changes of passive reference pattern	Homogenous change for ageing Local effects for damage	See 5.4.8	See 5.4.8	See 5.4.8	See 5.4.8
5.4.9	Manual interference	Based on VBPDPP specific analysis	See 5.4.9	See 5.4.9	See 5.4.9	See 5.4.9
5.4.10	Optical occlusion	See 5.4.10	X (test piece position 5.4.10)	X (test piece position 5.4.10)		

^a Specific tests may be required depending on an analysis of the design.

^b For ease of use, testing at 0,5m may be performed if the minimum operating distance stated by the supplier is below this distance. Tests at other and/or additional operating distance(s) may be required based on analysis.

^c Determining the location of the test piece within the detection zone may require analysis of the system to ensure that a worst case test is performed (e.g. when the sensor axis is not perpendicular to the passive reference pattern).

d	Effects of ageing of components, undetected faults of components and pollution on the surface of the optical window of the housing should be addressed within the endurance test, otherwise additional tests may be necessary.
e	VBDPPP in test chamber – open test chamber – start test within 1 min.
f	VBDPPP in test chamber – open test chamber – test without condensation

5.2.1.2 Integrity of the VBDPPP detection capability

It shall be verified that the VBDPPP detection capability is continuously maintained or the ESPE does not fail to danger by systematic analysis of the design of the VBDPPP, using testing where appropriate and/or required, taking into account 4.2.12.1 and 4.2.12.5.

5.2.1.3 Endurance test of the detection capability

It shall be verified that the detection capability is maintained by carrying out an endurance test as follows. The results of the analysis and testing according to 5.2.1.2 shall be used to determine the conditions and the appropriate test piece (see 4.2.13) to use for this test.

A limited functional test B (B test) in accordance with 5.2.3.3 of IEC 61496-1:2020 shall be carried out with the ESPE in continuous operation under the conditions determined. The test piece shall be placed in a position with minimum contrast of the evaluation image between passive reference pattern and test piece and left in this position for a time period of 96 h.

Addition after 5.2.8.4:

5.2.9 Verification of optical performance

A systematic analysis of the electro-optical subsystem shall be carried out to determine

- a) confirmation of any filtering techniques (especially software filtering algorithms) employed, and their characteristics;
- b) the decision criteria used to determine whether or not the defined test piece(s) is (are) detected as being inside the detection zone;
- c) the discrimination of object in front of passive reference pattern in accordance with 4.2.12.5;
- d) the effect of undetected faults, in accordance with 4.2.2.4, on the electro-optical characteristics;
- e) worst-case response time;
- f) the effect of environmental influence.

The results of this analysis shall be used to determine if the requirements of 4.1.2 can be met.

5.2.10 Wavelength

The wavelength used in the VBDPPP shall be verified either by inspection of the device data sheets or by measurement.

5.2.11 Radiation intensity

If the emitting element uses LED technology, the radiation intensity shall be verified by measurement in accordance with IEC 62471 and inspection of the technical documentation provided by the supplier.

If the emitting element uses Laser technology, the radiation intensity shall be verified by measurement in accordance with IEC 60825-1 and inspection of the technical documentation provided by the supplier. The marking as a class 1 or class 1M laser shall be verified for correctness.

5.3 Performance testing under fault conditions

5.3.2 Type 1 ESPE

This subclause of IEC 61496-1:2020 is not applicable.

5.3.3 Type 2 ESPE

This subclause of IEC 61496-1:2020 is not applicable.

5.3.4 Type 3 ESPE

Addition:

It shall be verified that the drift or ageing of components that influence the detection capability will be detected within a time period of 5 s according to 4.3.11 and shall lead to a lock-out condition.

A combination of one or more of the following is sufficient to verify the requirement to combine single faults with operating conditions/influences as required by 4.2.2.1 of IEC 61496-1:2020.

- analysis;
- simulation; and
- tests carried out in the presence of a single fault, where relevant.

5.3.5 Type 4 ESPE

This subclause of IEC 61496-1:2020 is not applicable.

5.4 Environmental tests

5.4.4 Mechanical influences

5.4.4.1 Vibration

Addition:

At the end of the tests, the VBPDPP shall be inspected for the absence of damage including displacement of optical components and mounting brackets. It shall be verified by test that the detection zone has not changed in orientation, size or position.

5.4.4.2 Shock

Addition:

At the end of the tests, the VBPDPP shall be inspected for the absence of damage including displacement of optical components and mounting brackets. It shall be verified by test that the detection zone has not changed in orientation, size or position.

5.4.6 Light interference

5.4.6.1 General

Replacement:

Each test shall be carried out at the operating distance as specified in Table 422, and under the stated conditions as a minimum requirement. Additional tests shall be carried out under different combinations of operating distances and environmental conditions when

- the supplier states higher immunity levels, which shall be verified by testing at those levels with appropriate light sources, and/or
- an analysis shows such tests to be necessary.

In the following test procedures, unless otherwise stated, the light intensity limits are contributed by the interfering light source. The ambient light values should be added during light intensity measurements.

Table 422 gives an overview of the light interference tests.

Table 422 – Overview of light interference tests

Test Num.	Sub clause	Test related to ^a	Light source / Test sequence ^a	Light intensity	Maximum operating distance from sensing device to passive reference pattern		Minimum operating distance from sensing device to passive reference pattern ^b	
					Test piece at minimum detection distance ^c	Test piece on passive reference pattern ^c	Test piece at minimum detection distance ^c	Test piece on passive reference pattern ^c
1	5.4.6.4	Normal operation- Interference on pattern	Incandescent / Test sequence 1	1 500 lx	X	X	X	X
2	5.4.6.4	Normal operation- Interference on pattern	Incandescent / Test sequence 1	100 lx	X	X	X	X
3	5.4.6.4	Normal operation- Interference on pattern	Incandescent with shadow / Test sequence 1	1 500 lx bright area – ≤750 lx shadow area	X	X		
4	5.4.6.5	Failure to danger- Interference on pattern	Incandescent / Test sequence 2	3 000 lx	X	X	X	X
5	5.4.6.5	Failure to danger- Interference on pattern	Incandescent / Test sequence 2	50 lx	X	X	X	X
6	5.4.6.6	Normal operation- Interference on sensing device	Incandescent / Test sequence 1	1500 lx over ambient light		X		

Test Num.	Sub clause	Test related to ^a	Light source /Test sequence ^a	Light intensity	Maximum operating distance from sensing device to passive reference pattern		Minimum operating distance from sensing device to passive reference pattern ^b	
					Test piece at minimum detection distance ^c	Test piece on passive reference pattern ^c	Test piece at minimum detection distance ^c	Test piece on passive reference pattern ^c
7	5.4.6.6	Normal operation-Interference on sensing device	Line frequency fluorescent / Test sequence 1	750 lx		X		
8	5.4.6.6	Normal operation-Interference on sensing device	High frequency fluorescent / Test sequence 1	750 lx		X		
9	5.4.6.7	Failure to danger-Interference on sensing device	Incandescent / Test sequence 2	3 000 lx		X		
10	5.4.6.7	Failure to danger-Interference on sensing device	Line frequency fluorescent / Test sequence 2	1 500 lx		X		
11	5.4.6.7	Failure to danger-Interference on sensing device	High frequency fluorescent / Test sequence 2	1 500 lx		X		
12	5.4.6.7	Failure to danger-Interference on sensing device	Laser beam pointer / Test sequence 3	Between 0,7 mW and 1 mW		X		
13	5.4.6.7	Failure to danger-Interference on sensing device	VBDPP of identical design / Test sequence 3			X		
14	5.4.6.7	Failure to danger-Interference on sensing device	Incandescent / Test sequence 3	3 000 lx decreasing to 0 lx		X		

^a Specific tests may be required depending on an analysis of the design.

^b For ease of use testing at 0,5 m may be performed if the minimum operating distance stated by the supplier is below this distance. Tests at other and/or additional operating distance(s) may be required based on analysis.

^c Determining the location of the test piece within the detection zone may require analysis of the system to ensure that a worst case test is performed (e.g. when the sensor axis is not perpendicular to the passive reference pattern).

Addition:

5.4.6.4 Normal operation – Interference on passive reference pattern

The ESPE shall continue in normal operation throughout test sequence 1 in 5.4.6.3 of IEC 61496-1:2020 using each of the following types of interfering light, positioned outside the sensing zone. Tests shall be carried out at the distances shown in Table 422.

Light intensity measurements shall be made in accordance to Figure 3.

- The incandescent light source of 5.4.6.2 of IEC 61496-1:2020 producing a light intensity of 1 500 lx.
- The incandescent light source of 5.4.6.2 of IEC 61496-1:2020 producing a light intensity of 100 lx without any additional ambient light.
- Single incandescent light source of 5.4.6.2 of IEC 61496-1:2020 producing a light intensity of 1 500 lx with a cylindrical object held in front of the light source and outside the tolerance zone producing a shadow on the passive reference pattern. The size of the shadow shall be within a range of 1 to 10 times the detection capability. The light intensity within the shadowed area shall be below 50 % of the bright area.
- The luxmeter shall be positioned on the background and perpendicular to the optical axis.
- The test piece shall be moved throughout the shadow within the detection zone.

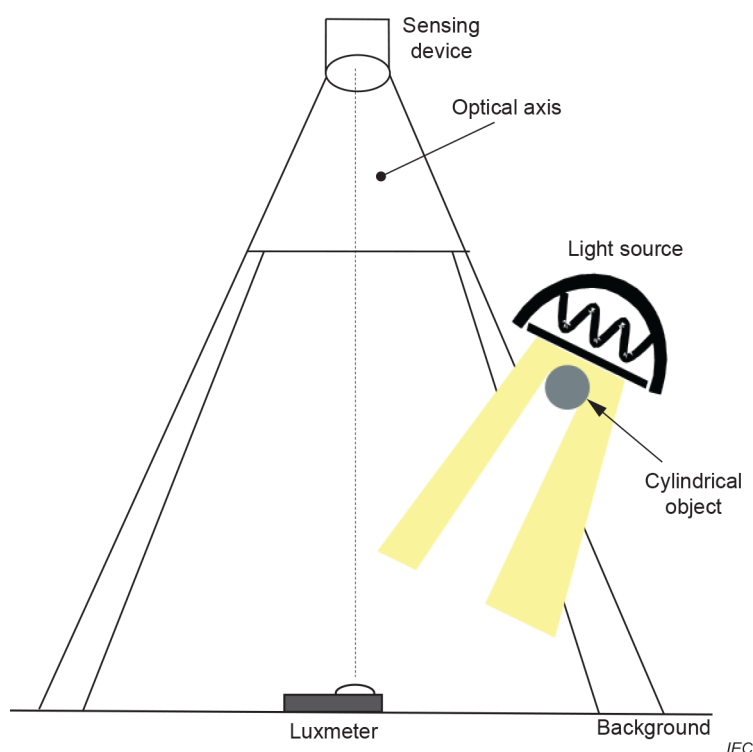

Figure 3 – Light intensity measurement setup for indirect light tests

5.4.6.5 Failure to danger – Interference on passive reference pattern

The ESPE shall not fail to danger throughout test sequence 2 in 5.4.6.3 of IEC 61496-1:2020 using each of the following types of interfering light, positioned outside the sensing zone. Tests shall be carried out at distances shown in Table 422.

Light intensity measurements shall be made in accordance to Figure 3.

NOTE Light intensity values are based on values given by EN 12464-1. The position and direction of the luxmeter is limited to achieve a reproducible light intensity value.

- The incandescent light source of 5.4.6.2 of IEC 61496-1:2020 producing a light intensity increase of 3 000 lx
- The incandescent light source of 5.4.6.2 of IEC 61496-1:2020 producing a light intensity of 50 lx without any additional ambient light.

5.4.6.6 Normal operation – Interference on sensing device

The ESPE shall continue in normal operation throughout test sequence 1 in 5.4.6.3 of IEC 61496-1:2020 using each of the following types of interfering light, positioned outside the sensing zone but adjacent to the tolerance zone. Tests shall be carried at distances shown in Table 2.

Light intensity measurements shall be made in accordance with Figure 4.

- The incandescent light source of 5.4.6.2 of IEC 61496-1:2020 producing a light intensity increase of 1 500 lx.
- The line frequency fluorescent light source of 5.4.6.2 of IEC 61496-1:2020 producing a light intensity increase of 750 lx.
- The high frequency fluorescent light source of 5.4.6.2 of IEC 61496-1:2020 producing a light intensity increase of 750 lx.
- The luxmeter shall be positioned on the sensing device and perpendicular to the optical axis.
- The light source shall be positioned adjacent to the tolerance zone.

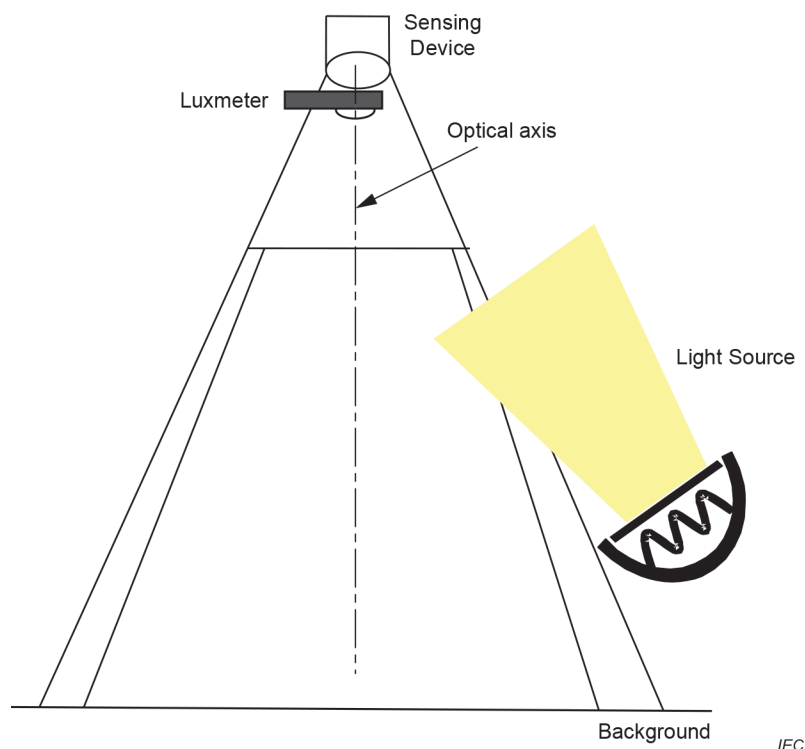

Figure 4 – Light intensity measurement setup for direct light tests

5.4.6.7 Failure to danger – Interference on sensing device

Interfering light sources shall be positioned outside the sensing zone but adjacent to the tolerance zone. Tests shall be carried at distances shown in Table 422.

Light intensity measurements shall be made in accordance to Figure 4.

The ESPE shall not fail to danger throughout test sequence 2 in 5.4.6.3 of IEC 61496-1:2020 using each of the following types of interfering light:

- The incandescent light source of 5.4.6.2 of IEC 61496-1:2020 producing a light intensity of 3 000 lx.
- The line frequency fluorescent light source of 5.4.6.2 of IEC 61496-1:2020 producing a light intensity increase of 1 500 lx.
- The high frequency fluorescent light source of 5.4.6.2 of IEC 61496-1:2020 producing a light intensity increase of 1 500 lx.

The ESPE shall not fail to danger throughout test sequence 3 in 5.4.6.3 of IEC 61496-1:2020 using each of the following types of interfering light:

- The laser beam pointer of 5.4.6.2 of IEC 61496-1:2020 with the laser beam pointer positioned inside the aperture of the sensing device objective.
- A VBPDPP of identical design, if analysis shows that the VBPDPP is sensitive to such interference.
- The incandescent light source of 5.4.6.2 of IEC 61496-1:2020 decreases from 3 000 lx to 0 lx in steps of 1 000 lx. Test sequence 3 shall be repeated at each step of decreased brightness.

5.4.7 Pollution interference

A systematic analysis of the design of the VBPDPP shall be carried out to decide which test methods and test conditions are appropriate to satisfy the requirements of 4.3.7. These tests shall be carried out to test for no failure to danger.

Changes based on pollution which lead to a reduction of the discrimination against the object which shall be detected have to be considered.

The test setup should include the whole field of view of the monitored passive reference pattern.

NOTE Specific test procedures will be developed.

5.4.8 Changes of passive reference pattern

A systematic analysis of the design of the VBPDPP shall be carried out to decide which tests and test methods are appropriate to satisfy the requirements of 4.3.8. These tests shall be carried out to test for no failure to danger.

Ageing of the passive reference pattern shall be considered as homogenous change over the whole pattern.

Damage of the passive reference pattern shall be considered as local effect on the pattern.

Changes of the passive reference pattern which lead to a reduction of the discrimination against the object which shall be detected have to be considered.

NOTE Specific test procedures will be developed.

5.4.9 Manual interference

A systematic analysis of the design of the VBPDPP shall be carried out to decide which tests and test methods are appropriate to satisfy the requirements of 4.3.9. These tests shall be carried out to test for no failure to danger.

NOTE Specific test procedures will be developed.

5.4.10 Optical occlusion

Immunity against optical occlusion within the detection zone or the zone with limited detection capability shall be tested as follows:

- a) The object used for simulating optical occlusion shall be a cylinder with a minimum effective length of 0,3 m. The surface of the test piece shall have a coefficient of diffuse reflection value of less than 20 % at the operating wavelength.
- b) The diameter of the occluding object shall be 5 mm unless determined otherwise by the analysis of 4.3.10.
- c) During the test, the occluding object shall be used parallel to the passive reference pattern plane of the VBPDPP.
- d) The detection zone shall be set to maximum, when applicable.
- e) The test shall be carried out by placing the occluding object adjacent to the tolerance zone within the detection zone or the zone with limited detection capability as near as possible to the VBPDPP with the OSSDs in the ON-state.
- f) The test piece in accordance to 4.2.13 shall be used for the C-tests to be performed.
- g) C-tests shall be performed to verify that the stated detection capability is maintained in the presence of optical occlusion. The test piece shall be moved between the occluding object and the passive reference pattern as close as possible to the occlusion object and at the stated maximum detection distance.
- h) Additional tests shall be carried out when the analysis of 4.3.10 shows that the following can affect the immunity to optical occlusion:
 - 1) distances between the VBPDPP and the occluding object other than those stated above;
 - 2) dimensions of the detection zone other than the maximum;
 - 3) other distances between the occluding object and the test piece;
 - 4) different diameters of the occluding object at different distances from the VBPDPP;
 - 5) different positions of the occluding object in front of the VBPDPP (for example, different angles); and/or
 - 6) more than one occluding object.

6 Marking for identification and for safe use

This clause of IEC 61496-1:2020 is applicable except as follows:

6.1 General

Addition:

- l) indication of the zone of detection.

The markings required by 6.1 b), c) and d) of IEC 61496-1:2020 may alternatively be given in the accompanying documents.

7 Accompanying documents

This clause of IEC 61496-1:2020 is applicable except as follows:

Additions:

- aaa) instruction that it shall be verified that the view of the passive reference pattern within the detection zone and tolerance zone is not blocked by parts of the machine or other objects;
- bbb) instruction that the detection capability dimension shall be added to the safe distance calculations of ISO 13855. This is because response time specifications assume that the object can be entirely within the detection zone before it is detected;
- ccc) the manufacturer shall inform the user of potential problems not covered by the requirements of this document;
- ddd) the manufacturer shall describe procedures for permanent fixing of passive reference pattern and further measures (for example prevent easy access for workers to additional passive reference pattern);
- eee) if the VBPDPP has a zone of limited detection capability, the manufacturer shall provide information as required in 4.1.6;
- fff) application examples showing the tolerance zone(s) if applicable;
- ggg) dimensions of maximum and minimum detection zone(s) and tolerance zone(s);
- hhh) information about the minimum required distance between the border of a detection zone and the surrounding environment without detecting, for example, walls or parts of machines in order to guarantee reliability in operation;
- iii) for setting the detection zone(s) including consideration of the tolerance zone(s) and details on other optional functions of the VBPDPP, described in Annex A of this document if these options are available. A clear statement shall be given when a zone(s) is (are) described, whether its description is related to the detection zone(s) as defined in 3.4 of IEC 61496-1:2020 or the combination of the detection zone(s) and the tolerance zone(s).

Annex A (normative)

Optional functions of the ESPE

Annex A of IEC 61496-1:2020 applies except as follows:

Clause A.8 does not apply.

Additional optional functions:

A.10 Selection of multiple detection zones

A.10.1 Functional requirements

If an ESPE has more than one safety-related detection zone, a single fault shall not lead to an unintended change from one selected zone to another zone. In cases where a single fault which does not cause a failure to danger of the ESPE is not detected, the occurrence of a further fault internal to the ESPE shall not cause a failure to danger.

Where the input signals are derived from device(s) external to the ESPE, this device(s) should meet the relevant requirements of other appropriate standards (for example ISO 13849-1, IEC 61508, IEC 62061).

Single faults that prevent an intended change from one selected zone to another or prevent the activation of an additional safety-related detection zone shall cause the ESPE to go to a lock-out condition when a demand requires an activation of another zone or an activation of an additional zone. The specified response time(s) shall be maintained in this case.

NOTE 1 It is possible that each zone has a different response time as specified by the manufacturer.

If a detection zone is changed in size on-line for example by external inputs, the same requirement applies.

The activation of the detection zones shall be monitored by the ESPE. The user shall have the possibility to configure the sequence of activation of the detection zones which is monitored by the ESPE. If an incorrect sequence of activation of the detection zones is detected, the ESPE shall respond by going to a lock-out condition.

The possibility that persons may already be within the detection zone at the moment of switching between different detection zones should be considered.

NOTE 2 The automatic selection of safety-related detection zones is not a muting function (as described in A.7 of IEC 61496-1:2020).

A.10.2 Verification

The functional requirements for the selection of multiple detection zones shall be verified as follows.

- a) Verification that a single fault does not lead to an unintended change from one selected zone to another zone. Verification that a single fault does not prevent an intended change from one selected zone to another or prevent the activation of an additional safety-related detection zone. Verification, that a further fault will not lead to a failure to danger, shall be carried out according to 5.3.4.
- b) Verification that common-mode failures cannot lead to a deactivation or variation of the detection zones.

- c) Verification that the specified response time of the ESPE is maintained in the case of switching between different detection zones.
- d) Verification that the user has the possibility to configure the sequence of activation of the detection zones which is monitored by the ESPE.
- e) Verification that the ESPE goes to the lock-out condition when the sequence of activation differs from that configured by the user.

A.11 Automatic setting of detection zones

A.11.1 Functional requirements

If the ESPE has the possibility to automatically set the detection zone(s), the setting of the detection zone shall be valid only after being verified by penetrating all segments of the detection zone at least once in a corridor with a maximum width of 0,75 m along the border of the detection zone in the plane of the passive reference pattern. The corridor shall be inside the detection zone.

The automatic setting of a detection zone shall not be possible without using a tool. This tool can be, for example, a password protected software configuration program.

When determining the ranging accuracy of an automatically set detection zone, all conditions as listed in this document shall be taken into account, especially environmental interferences.

A.11.2 Verification

The functional requirements for automatically setting a detection zone shall be verified by the following tests:

- a) tests according to A.9.2 a), b) and c);
- b) test that the detection zone was set correctly by penetrating all segments of the detection zone at least once in a corridor with a maximum width of 0,75 m along the border of the detection zone;
- c) verification that a tool (for example, a password protected software configuration program) is necessary to enable automatic setting of a detection zone in the plane of the passive reference pattern.

Annex B
(normative)

**Catalogue of single faults affecting the electrical equipment
of the ESPE, to be applied as specified in 5.3**

Annex B of IEC 61496-1:2020 is applicable except as follows.

Addition:

B.7 Imaging sensor

Faults considered	Exclusions
Wrong line addressing	None
Wrong column addressing	None
Crosstalk between lines, columns and pixels	None
Static image (no new image)	None
Stuck at high pixel	None
Stuck at low pixel	None
Change in register settings, if applicable	None
Failure in the analog to digital converter, if applicable	None
Failure in data pre-processing, if applicable (see Figure 1)	None

Annex AA (informative)

The positioning of VBPD in respect of parts of the human body

AA.1 Calculation of distances for electro-sensitive protective equipment employing vision based protective devices (VBPD)

NOTE 1 ISO 13855 provides a methodology to determine the minimum distance S from specific sensing or actuating devices of protective equipment to a danger zone. Clause 6 of ISO 13855:2010 details the calculation of minimum distances for electro-sensitive protective equipment employing active opto-electronic protective systems. This Annex AA adopts the given approach and extends it where necessary. It is foreseen that after some experience, the methodology will be presented to the committees preparing ISO 13855 and IEC 62046 for adoption and integration in their standards.

When calculating minimum distances, the requirements and formulae given by ISO 13855:2010, Clause 6 should be taken into account including additions given by Clauses AA.2, AA.3 and AA.4.

ISO 13855 distinguishes in the calculation of the minimum distance between:

- detection zone orthogonal to the direction of approach, and
- detection zone parallel to the direction of approach

Both cases can be applied for a three-dimensional volume; it is allowed to choose the resulting lower minimum distance S . Analysis has shown that the formulae for detection zones orthogonal to the direction of approach lead to a lower or equal minimum distance S in the cases described below. For the Formulae AA.5 to AA.9 it is considered that the outer shell of the three-dimensional detection zone is normal to the reference plane, e.g. floor. Other shapes such as ball-shaped or trapezoidal need further consideration. In addition, possible circumventing of an VBPD by reaching over the detection zone should be addressed according to ISO 13855:2010, Table 1.

To ensure that the value C_{RO} according to ISO 13855:2010, Table 1 is smaller than the value of $(C + d)$ calculated according to the formulae below independent of the height a of the hazard zone, the height b of the upper edge of the detection zone of the VBPD should be 1 400 mm as a minimum for a detection capability >55 mm and 2 400 mm as a minimum in all other cases.

NOTE 2 A height b equal or greater than 1 400 mm respectively 2 400 mm means that there is no possible circumventing of an ESPE according to ISO 13855 by reaching over the detection zone. In cases where the above recommendation is not followed, Table 1 of ISO 13855:2010 is applicable to determine the correct distance.

AA.2 Calculation of the overall minimum distance S_o

When calculating the size or volume of a zone that is used to prevent a person reaching the hazard zone before the termination of the hazardous machine function an overall minimum distance S_o should be calculated by Formulae (AA.1) and (AA.4). Formula (AA.2) is a general formula given by ISO 13855.

$$S_o = S + S_a \quad (\text{AA.1})$$

$$S = (K \times T) + C \quad (\text{AA.2})$$

$$S_a = C_{tz} + d \quad (\text{AA.3})$$

$$S_o = (K \times T) + C + C_{tz} + d \quad (\text{AA.4})$$

where:

- S_o is the overall minimum distance, in millimetres, combining the minimum distance S and an additional distance S_a ;
- S is the minimum distance, in millimetres, from the hazard zone to the detection point, line, plane or zone;
- S_a is an additional distance, in millimetres, combining the effects of systematic and random influences;
- K is a parameter in millimetres per second, derived from data on approach speeds of the body or parts of the body (see ISO 13855 for details);
- T is the overall system stopping performance in seconds;
- C is an additional distance in millimetres, based on the distance, which a part of the body may be moving towards the hazard zone prior to the actuation of the protective device;
- C_{tz} is an additional distance in millimetres, based on the tolerance zone of the protective device to satisfy systematic and random influences;
- d is the detection capability in millimetres (see Figure AA.4, Figure AA.5 and Figure AA.6).

NOTE Protective devices employing a volume as a detection zone will normally require a test piece to be inside the detection zone with a dimension of at least its stated detection capability. This is taken into account by the corresponding test procedures (see for example Clause 5). Therefore the dimension of the test piece (d) is part of the additional distance S_a in the Formulae AA.3 and AA.4. If partial intrusion (see AA.5, Example 2) satisfies the requirements of this document, only the relevant portion of the dimension d is used in those formulae (i.e. d_1 in Figure AA.4 to Figure AA.6).

AA.3 Vision based protective devices with a detection capability > 40 mm and ≤ 55 mm

The minimum distance S in millimetres should be calculated by Formula (AA.5) for VBPD having a detection capability in the range > 40 mm and ≤ 55 mm:

$$S = (K \times T) + C_{40} + C_{55} \quad (\text{AA.5})$$

where:

- S is the minimum distance, in millimetres, from the hazard zone to the detection point, line, plane or zone;
- K is a parameter in millimetres per second, derived from data on approach speeds of the body or parts of the body (see ISO 13855 for details);
- T is the overall system stopping performance in seconds;
- C_{40} is an additional distance in millimetres, based on formulae given by ISO 13855 with $C_{40} = 8 (d - 14 \text{ mm}) = 8 (40 \text{ mm} - 14 \text{ mm}) = 208 \text{ mm}$;
- C_{55} is an additional distance in millimetres, based on the formula $C_{55} = 12 (d - 40 \text{ mm})$;
- d is the detection capability in millimetres.

Then

$$S = (K \times T) + 208 \text{ mm} + 12 (d - 40 \text{ mm}) \quad (\text{AA.6})$$

$$S = (K \times T) + 12 d - 272 \text{ mm} \quad (\text{AA.7})$$

NOTE The formula for C_{55} is derived from an estimation based on data given by B. Flügel, H. Greil, K. Sommer, Anthropologischer Atlas, Verlag Tribüne Berlin 1986, ISBN 3-7303-0042-3.

For the calculation of C_{40} , the value of d has to be 40 mm, irrespective of the detection capability stated by the manufacturer. For the calculation of C_{55} , the value of d is the detection capability stated by the manufacturer.

AA.4 Vision based protective devices with a detection capability > 55 mm and ≤ 200 mm

The minimum distance S in millimetres should be calculated by Formula (AA.8) for VBPD having a detection capability in the range > 55 mm and ≤ 200 mm.

$$S = (K \times T) + C \quad (\text{AA.8})$$

where:

- S is the minimum distance, in millimetres, from the hazard zone to the detection point, line, plane or zone;
- K is a parameter in millimetres per second, derived from data on approach speeds of the body or parts of the body with $K = 1\,600$ mm/s (see ISO 13855 for details);
- T is the overall system stopping performance in seconds;
- C is an additional distance of 850 mm; according to ISO 13855 this value is considered to be the standard arm reach.

Then

$$S = (1\,600 \text{ mm/s} \times T) + 850 \text{ mm} \quad (\text{AA.9})$$

AA.5 Examples of detection zone and tolerance zone

For description of letter symbols used in Figure AA.1 to Figure AA.6, see Clause AA.2.

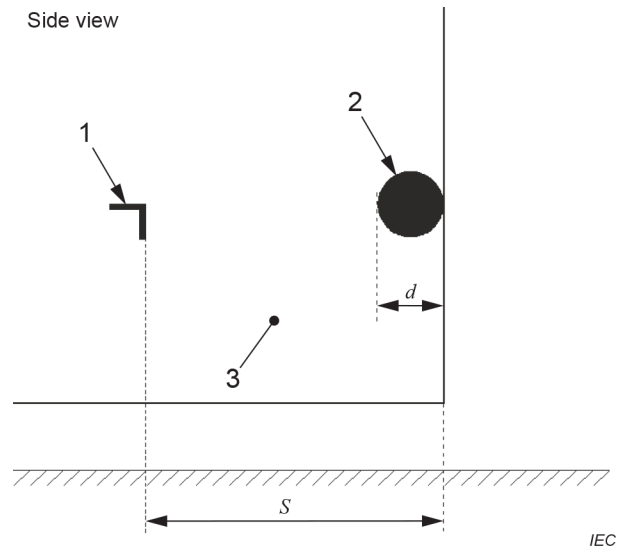

Key

- 1 – Hazard zone
- 2 – Test piece
- 3 – Detection zone

Figure AA.1 – Minimum distance S – Example 1

According to the general description of the test procedure in 5.2.1.1 the test piece shall be detected when placed inside the detection zone as far as the stated detection capability d .

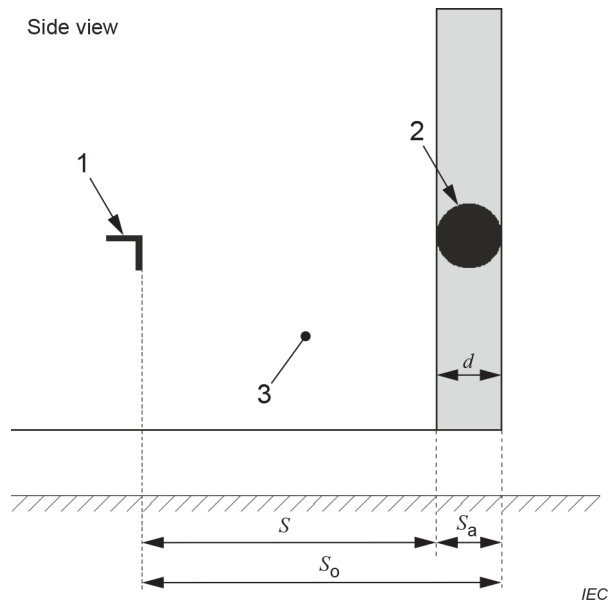

Key

- 1 – Hazard zone
- 2 – Test piece
- 3 – Detection zone

Figure AA.2 – Overall minimum distance S_0 without tolerance zone – Example 1

The dimension of the detection capability d will be added to the minimum distance S to ensure the correct distance between the hazard zone and an object.

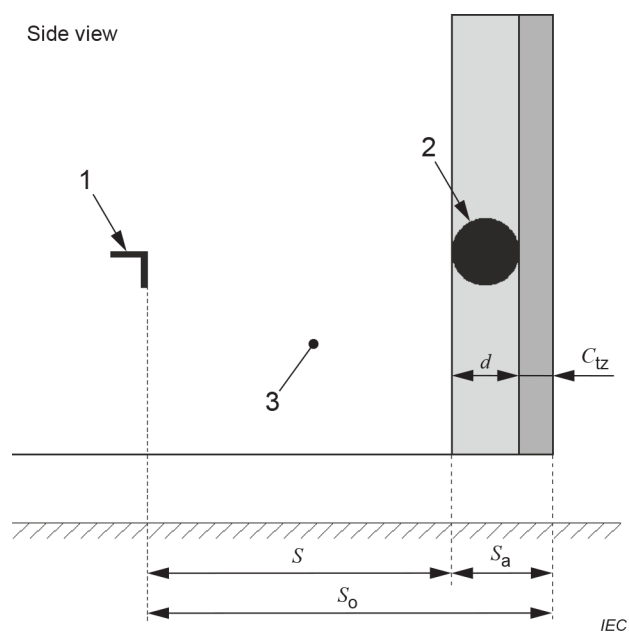

Key

- 1 – Hazard zone
- 2 – Test piece
- 3 – Detection zone

Figure AA.3 – Overall minimum distance S_0 including tolerance zone – Example 1

If there is a tolerance zone, it should be added to make up the additional distance S_a .

NOTE 1 At this time, there are no VBPDPs known to be using a tolerance zone.

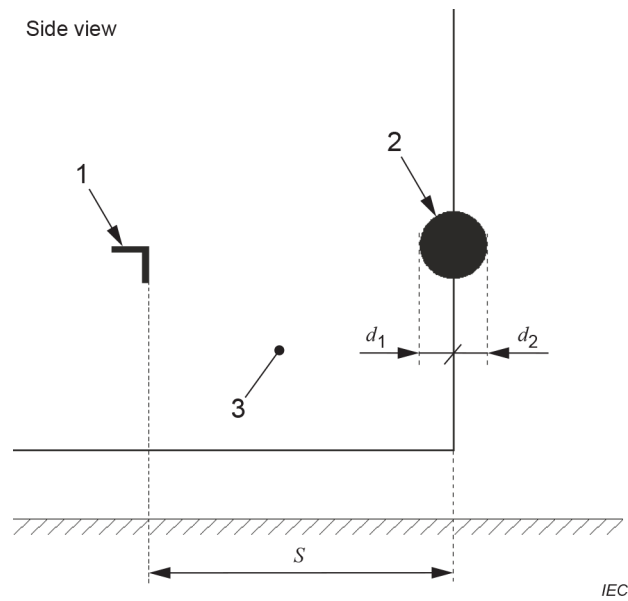

Key

- 1 – Hazard zone
- 2 – Test piece
- 3 – Detection zone

$$d = d_1 + d_2$$

Figure AA.4 – Minimum distance S – Example 2

According to the general description of the test procedure in 5.2.1.1, the test piece shall be detected when placed inside the detection zone as far as the stated detection capability d . If partial intrusion of an object into the detection zone as shown by the dimension d_1 in Figure AA.4 leads to detection, then the dimension d_1 will be added to the minimum distance S to ensure the correct distance between the hazard zone and an object, see Figure AA.5.

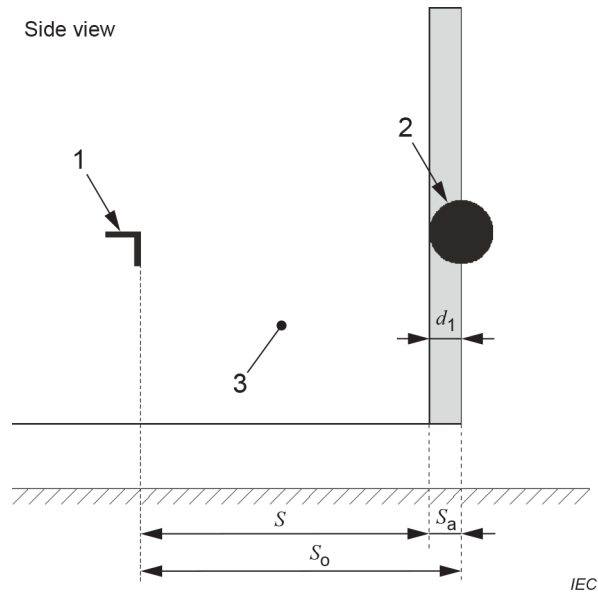

Key

- 1 – Hazard zone
- 2 – Test piece
- 3 – Detection zone
- d_1 – see Figure AA.4

Figure AA.5 – Overall minimum distance S_0 without tolerance zone – Example 2

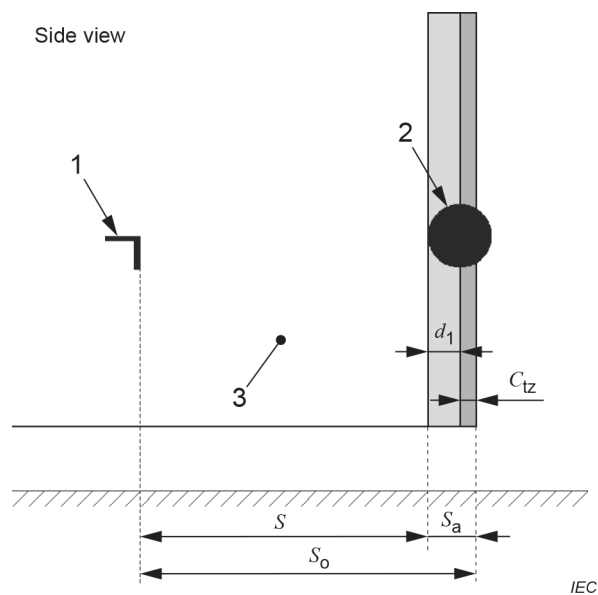

Key

- 1 – Hazard zone
- 2 – Test piece
- 3 – Detection zone
- d_1 – see Figure AA.4

Figure AA.6 – Overall minimum distance S_0 including tolerance zone – Example 2

If there is a tolerance zone, it should be added to make up the additional distance S_a .

NOTE 2 At this time, there are no VBPDPPs known to be using a tolerance zone.

Bibliography

Addition:

ISO 15534-1:2000, *Ergonomic design for the safety of machinery – Part 1: Principles for determining the dimensions required for openings for whole-body access into machinery*

ISO 15534-2:2000, *Ergonomic design for the safety of machinery – Part 2: Principles for determining the dimensions required for access openings*

ISO 15534-3:2000, *Ergonomic design for the safety of machinery – Part 3: Anthropometric data*

DIN 33402-2:2020, *Ergonomics. Human body dimensions – Part 2: Values*

EN 12464-1:2021, *Light and lighting. Lighting of work places – Part 1: Indoor work places*

EN 547-3:1996+A1:2008, *Safety of machinery – Human body measurement – Part 3: Anthropometric data*

B. Flügel, H. Greil, K. Sommer, *Anthropologischer Atlas*, Verlag Tribüne Berlin 1986, ISBN 3-7303-0042-3 (available in German only)

[\(Continued from second cover\)](#)

The Committee has reviewed the provisions of the following International Standards/Other Publications referred in this adopted standard and has decided that they are acceptable for use in conjunction with this standard:

<i>International Standard</i>	<i>Title</i>
IEC 60825-1 : 2014	Safety of laser products — Part 1: Equipment classification and requirements

Only English language text has been retained while adopting it in this Indian Standard, and as such the page numbers given here are not the same as in the International Standard.

For the purpose of deciding whether a particular requirement of this standard is complied with, the final value, observed or calculated expressing the result of a test, shall be rounded off in accordance with IS 2 : 2022 'Rules for rounding off numerical values (*second revision*)'. The number of significant places retained in the rounded off value should be the same as that of the specified value in this standard.

Bureau of Indian Standards

BIS is a statutory institution established under the *Bureau of Indian Standards Act, 2016* to promote harmonious development of the activities of standardization, marking and quality certification of goods and attending to connected matters in the country.

Copyright

BIS has the copyright of all its publications. No part of these publications may be reproduced in any form without the prior permission in writing of BIS. This does not preclude the free use, in the course of implementing the standard, of necessary details, such as symbols and sizes, type or grade designations. Enquiries relating to copyright be addressed to the Head (Publication & Sales), BIS.

Review of Indian Standards

Amendments are issued to standards as the need arises on the basis of comments. Standards are also reviewed periodically; a standard along with amendments is reaffirmed when such review indicates that no changes are needed; if the review indicates that changes are needed, it is taken up for revision. Users of Indian Standards should ascertain that they are in possession of the latest amendments or edition by referring to the website-www.bis.gov.in or www.standardsbis.in.

This Indian Standard has been developed from Doc No.: ETD 44 (23807).

Amendments Issued Since Publication

Amend No.	Date of Issue	Text Affected

BUREAU OF INDIAN STANDARDS

Headquarters:

Manak Bhavan, 9 Bahadur Shah Zafar Marg, New Delhi 110002

Telephones: 2323 0131, 2323 3375, 2323 9402

Website: www.bis.gov.in

Regional Offices:

Central : 601/A, Konnectus Tower -1, 6th Floor,
DMRC Building, Bhavbhuti Marg, New
Delhi 110002

Telephones

{ 2323 7617

Eastern : 8th Floor, Plot No 7/7 & 7/8, CP Block, Sector V,
Salt Lake, Kolkata, West Bengal 700091

{ 2367 0012
2320 9474

Northern : Plot No. 4-A, Sector 27-B, Madhya Marg,
Chandigarh 160019

{ 265 9930

Southern : C.I.T. Campus, IV Cross Road, Taramani, Chennai 600113

{ 2254 1442
2254 1216

Western : Manakalya, 4th Floor, NTH Complex (W Sector), F-10, MIDC, Andheri
(East), Mumbai 400093

{ 283 25838

Branches : AHMEDABAD, BENGALURU, BHOPAL, BHUBANESHWAR, CHANDIGARH, CHENNAI, COIMBATORE, DEHRADUN, DELHI, FARIDABAD, GHAZIABAD, GUWAHATI, HARYNA, HUBLI, HYDERABAD, JAIPUR, JAMMU & KASHMIR, JAMSHEDPUR, KOCHI, KOLKATA, LUCKNOW, MADURAI, MUMBAI, NAGPUR, NOIDA, PARWANOO, PATNA, PUNE, RAIPUR, RAJKOT, SURAT, VIJAYAWADA.