

कुंडलन तारे — परीक्षण पद्धतियाँ
भाग 3 यांत्रिक गुण-धर्म
(दूसरा पुनरीक्षण)

Winding Wires — Methods of Test
Part 3 Mechanical Properties
(*Second Revision*)

ICS 29.060.10

© BIS 2024
© IEC 2023



भारतीय मानक ब्यूरो
BUREAU OF INDIAN STANDARDS
मानक भवन, 9 बहादुर शाह ज़फर मार्ग, नई दिल्ली - 110002
MANAK BHAVAN, 9 BAHADUR SHAH ZAFAR MARG
NEW DELHI - 110002

www.bis.gov.in www.standardsbis.in

NATIONAL FOREWORD

This Indian Standard (Part 3) (Second Revision) which is identical to IEC 60851-3 : 2023 'Winding wires — Test methods — Part 3: Mechanical properties' issued by the International Electrotechnical Commission (IEC) was adopted by the Bureau of Indian Standards on the recommendation of the Winding Wire Sectional Committee and approval of the Electrotechnical Division Council.

This standard was originally published in 1993 and subsequently revised in 2012. This revision has been undertaken to align it with the latest version of IEC 60851-3 : 2023.

This standard is published in various parts. Other parts in this series are:

- Part 1 General
- Part 2 Determination of dimensions
- Part 4 Chemical properties
- Part 5 Electrical properties
- Part 6 Thermal properties.

The text of the IEC standard has been approved as suitable for publication as an Indian Standard without deviations. Certain conventions are, however, not identical to those used in Indian Standards. Attention is particularly drawn to the following:

- a) Wherever the words 'International Standard' appears referring to this standard, they should be read as 'Indian Standard'; and
- b) Comma (,) has been used as a decimal marker, while in Indian Standards the current practice is to use a point (.) as the decimal marker.

In this adopted standard, reference appears to International Standards for which Indian Standards also exists. The corresponding Indian Standards, which are to be substituted, are listed below along with their degree of equivalence for the editions indicated:

<i>International Standard</i>	<i>Corresponding Indian Standard</i>	<i>Degree of Equivalence</i>
IEC 60851-2 : 2009 Winding wires — Test methods — Part 2: Determination of dimensions	IS 13778 (Part 2) : 2013/ IEC 60851-2 : 2009 Winding wires — Test methods: Part 2 Determination of dimensions (<i>first revision</i>)	Identical
ISO 178 : 2019 Plastics — Determination of flexural properties	IS 13360 (Part 5/Sec 7) : 2022/ISO 178 : 2019 Plastics — Method of testing: Part 5 Mechanical properties, Section 7 Determination of flexural properties (<i>Second revision</i>)	Identical

For the purpose of deciding whether a particular requirement of this standard is complied with, the final value, observed or calculated expressing the result of a test, shall be rounded off in accordance with IS 2 : 2022 'Rules for rounding off numerical values (*second revision*)'. The number of significant places retained in the rounded off value should be the same as that of the specified value in this standard.

CONTENTS

INTRODUCTION.....	vi
1 Scope.....	1
2 Normative references.....	1
3 Terms and definitions.....	1
4 Test 6: Elongation.....	1
4.1 Elongation at fracture.....	1
4.2 Tensile strength.....	2
5 Test 7: Springiness.....	2
5.1 General.....	2
5.2 Round wire with a nominal conductor diameter from 0,080 mm up to and including 1,600 mm.....	2
5.2.1 Principle.....	2
5.2.2 Equipment.....	2
5.2.3 Procedure.....	4
5.3 Round wire with a nominal conductor diameter over 1,600 mm and rectangular wire.....	5
5.3.1 Principle.....	5
5.3.2 Equipment.....	5
5.3.3 Specimen.....	6
5.3.4 Procedure.....	6
6 Test 8: Flexibility and adherence.....	7
6.1 General.....	7
6.2 Mandrel winding test.....	7
6.2.1 Round wire.....	7
6.2.2 Rectangular wire.....	8
6.2.3 Covered bunched wire.....	9
6.3 Stretching test (applicable to enamelled round wire with a nominal conductor diameter over 1,600 mm).....	9
6.4 Jerk test (applicable to enamelled round wire with a nominal conductor diameter up to and including 1,000 mm).....	10
6.5 Peel test (applicable to enamelled round wire with a nominal conductor diameter over 1,000 mm).....	10
6.6 Adherence test.....	12
6.6.1 General.....	12
6.6.2 Enamelled rectangular wire.....	12
6.6.3 Impregnated fibre covered round and rectangular wire.....	12
6.6.4 Fibre covered enamelled round and rectangular wire.....	12
6.6.5 Tape-wrapped round and rectangular wire (for adhesive tape only).....	13
7 Test 11: Resistance to abrasion (applicable to enamelled round wire).....	13
7.1 General.....	13
7.2 Principle.....	13
7.3 Equipment.....	13
7.4 Procedure.....	14
8 Test 18: Heat bonding (applicable to enamelled round wire with a nominal conductor diameter over 0,050 mm up to and including 2,000 mm and to enamelled rectangular wire).....	15

8.1	General.....	15
8.2	Vertical bond retention of a helical coil.....	15
8.2.1	General	15
8.2.2	Nominal conductor diameter up to and including 0,050 mm.....	15
8.2.3	Nominal conductor diameter over 0,050 mm up to and including 2,000 mm	15
8.3	Bond strength of a twisted coil	18
8.3.1	General	18
8.3.2	Principle	18
8.3.3	Equipment	18
8.3.4	Specimen	18
8.3.5	Procedure.....	20
8.3.6	Result.....	20
8.4	Enamelled rectangular wire heat bonding.....	21
Annex A (informative) Bond strength of heat bonding wires		23
A.1	Calculation of the temperature of the twisted coil specimen	23
A.1.1	Method	23
A.1.2	Temperature coefficient.....	23
A.1.3	Calculation	23
A.2	Determination of the heating period	24
A.2.1	Voltage-time graphs.....	24
A.2.2	Voltage at maximum temperature	24
Annex B (informative) Friction test methods		29
B.1	General.....	29
B.2	Test A: Static coefficient of friction test method.....	29
B.2.1	Test method (applicable to enamelled round wires with a nominal conductor diameter from 0,050 mm up to and including 1,600 mm).....	29
B.2.2	Test apparatus	29
B.3	Test B: First dynamic coefficient of friction test method.....	30
B.3.1	Principle	30
B.3.2	Method of test.....	30
B.4	Test C: Second dynamic coefficient of friction test method (applicable to enamelled round wires with a nominal conductor diameter from 0,050 mm up to and including 1,600 mm).....	30
B.4.1	Test equipment.....	30
B.4.2	Test specimen	31
B.4.3	Specimen preparation.....	31
B.4.4	Procedure.....	32
B.5	Test D: Force of friction by the twisted pair method.....	33
B.5.1	Enamelled round wires with a nominal conductor diameter from 0,1 mm up to and including 1,500 mm	33
B.5.2	Test method	33
Bibliography.....		39
Figure 1 – Test equipment to determine springiness		3
Figure 2 – Construction and details of the mandrel (see Table 1).....		3
Figure 3 – Test equipment to determine springiness		6
Figure 4 – Test equipment for mandrel winding test		9
Figure 5 – Test equipment for jerk test.....		10

Figure 6 – Test equipment for peel test.....	11
Figure 7 – Scraper	12
Figure 8 – Cross-section of the wire after removal of the coating	12
Figure 9 – Test equipment for unidirectional scrape test	14
Figure 10 – Test equipment for bond retention of a helical coil.....	17
Figure 11 – Coil winder	19
Figure 12 – Oval shape coil	20
Figure 13 – Twisting device with a load applied to the twisted coil specimen.....	20
Figure 14 – Arrangement of supports	21
Figure 15 – Samples for heat bonding.....	22
Figure A.1 – Example of voltage-time graphs of twisted coil specimens with a nominal conductor diameter of 0,300 mm with isothermic graphs	25
Figure A.2 – Example of voltage-time graphs of twisted coil specimens with a nominal conductor diameter of 0,315 mm with isothermic graphs	26
Figure A.3 – Example of voltage-time graphs of twisted coil specimens with a nominal conductor diameter of 0,355 mm with isothermic graphs	27
Figure A.4 – Example of voltage-time graphs of twisted coil specimens with a nominal conductor diameter of 0,500 mm with isothermic graphs	28
Figure B.1 – Static coefficient of friction test apparatus.....	34
Figure B.2 – Dynamic coefficient of friction test apparatus	35
Figure B.3 – Diagram of a typical dynamic coefficient of friction tester	36
Figure B.4 – Material – sapphire (synthetic).....	37
Figure B.5 – Synthetic sapphires mounted on load block	37
Figure B.6 – Load applied perpendicular to wire path.....	38
Figure B.7 – Twisted specimen	38
Table 1 – Mandrels for springiness	4
Table 2 – Magnification to detect cracks	7
Table 3 – Load for peel test	11
Table 4 – Preparation of helical coils	16
Table 5 – Bond retention at elevated temperature.....	17
Table B.1 – Load block weights for dynamic coefficient of friction testing.....	32
Table B.2 – Twisted pair method.....	33

INTRODUCTION

This part of IEC 60851 forms an element of a series of standards, which deals with insulated wires used for windings in electrical equipment. The series has three groups describing:

- a) winding wires – Test methods (IEC 60851);
- b) specifications for particular types of winding wires (IEC 60317);
- c) packaging of winding wires (IEC 60264).

Indian Standard
WINDING WIRES — METHODS OF TEST
PART 3 MECHANICAL PROPERTIES
(*Second Revision*)

1 Scope

This part of IEC 60851 specifies the following test methods for winding wires:

- Test 6: Elongation;
- Test 7: Springiness;
- Test 8: Flexibility and adherence;
- Test 11: Resistance to abrasion;
- Test 18: Heat bonding.

For definitions, general notes on test methods and the complete series of test methods for winding wires, IEC 60851-1 applies. This document also provides recommended friction test methods in Annex B.

2 Normative references

The following documents are referred to in the text in such a way that some or all of their content constitutes requirements of this document. For dated references, only the edition cited applies. For undated references, the latest edition of the referenced document (including any amendments) applies.

IEC 60851-2:2009, *Winding wires – Test methods – Part 2: Determination of dimensions*
IEC 60851-2:2009/AMD1:2015
IEC 60851-2:2009/AMD2:2019

ISO 178:2019, *Plastics – Determination of flexural properties*

3 Terms and definitions

No terms and definitions are listed in this document.

ISO and IEC maintain terminology databases for use in standardization at the following addresses:

- IEC Electropedia: available at <https://www.electropedia.org/>
- ISO Online browsing platform: available at <https://www.iso.org/obp>

4 Test 6: Elongation

4.1 Elongation at fracture

Elongation is the increase in length expressed as a percentage of the original length.

A straight piece of wire shall be elongated to the point of fracture of the conductor at a rate of (5 ± 1) mm/s with an elongation tester or with tensile testing equipment with a free measuring length of between 200 mm and 250 mm. The linear increase at fracture shall be calculated as a percentage of the free measuring length.

Three specimens shall be tested. The three single values shall be reported. The mean value represents elongation at fracture.

4.2 Tensile strength

Tensile strength is the ratio of the force at fracture to initial cross-section.

A straight piece of wire shall be elongated to the point of fracture of the conductor at a rate of (5 ± 1) mm/s with tensile testing equipment with a free measuring length of between 200 mm and 250 mm and which records the force at fracture.

Three specimens shall be tested. The initial cross-section and the three single values of the force at fracture shall be reported. The mean value of the ratio of the force at fracture and the initial cross-section represents the tensile strength.

5 Test 7: Springiness

5.1 General

Springiness is the recoil measured in degrees after the wire is wound in the form of a helical coil or bent through an angle.

5.2 Round wire with a nominal conductor diameter from 0,080 mm up to and including 1,600 mm

5.2.1 Principle

A straight piece of wire is wound five times around a mandrel with a diameter and under a tension applied to the wire as specified in the relevant standard. The reading of the angle by which the end of the five turns recoils is the measure of springiness.

5.2.2 Equipment

Figure 1 shows an example of the test equipment with details of the mandrel given in Figure 2 and Table 1. Figure 2 indicates a helical groove, which may be used to facilitate winding. The provision of this groove, however, is not mandatory. The dial is marked with 72 equally spaced divisions so that with five turns of the wire the reading corresponds to the number of degrees that each turn springs back.

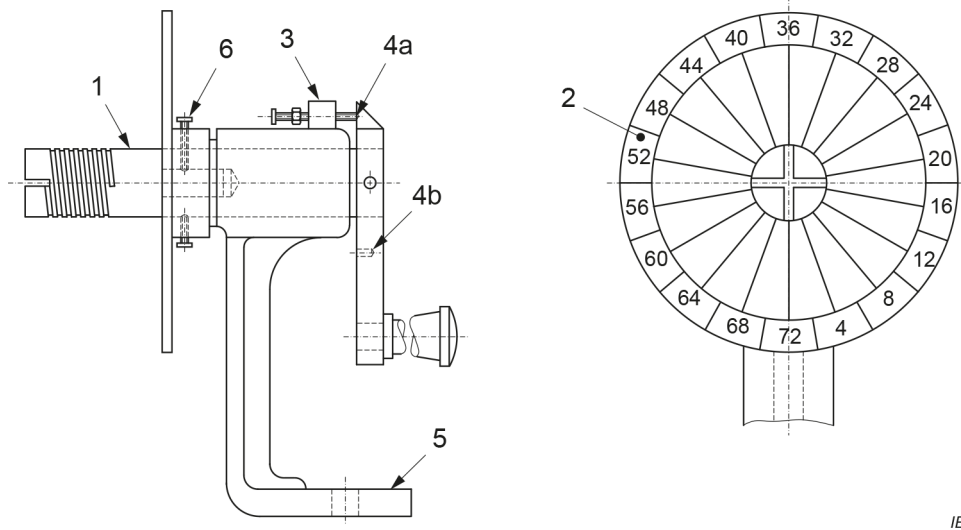

IEC

Key

- 1 mandrel
- 2 dial
- 3 locking device
- 4 locking device
- 5 base-plate
- 6 mandrel-fixing screw

Figure 1 – Test equipment to determine springiness

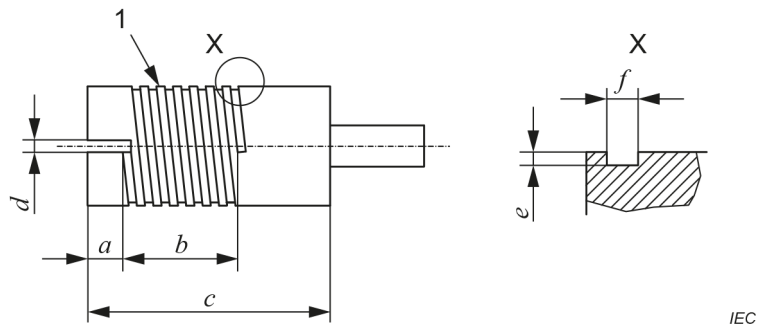

IEC

Key

- 1 7 threads
- 2 part X enlarged

Figure 2 – Construction and details of the mandrel (see Table 1)

Table 1 – Mandrels for springiness

Mandrel diameter ^a mm	Dimensions ^b mm					
	a	b	c	d	e	f
5	6,0	7,5	32	0,30	0,05	0,13
7	6,0	9,0	34	0,40	0,07	0,18
10	6,0	9,0	34	0,60	0,10	0,25
12,5	6,0	9,0	40	0,80	0,14	0,35
19	10,0	11,0	45	1,20	0,20	0,50
25	12,5	12,5	45	2,00	0,28	0,70
37,5	12,5	14,5	47	2,40	0,40	1,00
50	12,5	17,5	50	3,00	0,80	2,00

^a At the bottom of the groove, if provided.
^b See Figure 2.

5.2.3 Procedure

The specified mandrel shall be mounted and locked in position with its axis horizontal and with the slot or hole for fastening the wire corresponding with the zero of the dial. The mandrel shall be dusted with powdered talc (French chalk) to prevent the wire clinging to the mandrel.

A tension shall be applied to a straight piece of wire of about 1 m in length by attaching the specified load to one end of the wire. The handle to rotate the mandrel shall be unlatched. The other end of the wire shall be inserted into the slot or hole so that sufficient wire projects on the other side of the mandrel and the wire is in firm contact with the mandrel. The weight shall be slowly lowered with the wire suspended vertically below the mandrel and with the dial zero and the slot or hole pointing downwards.

With the free end of the wire being held securely, the mandrel shall be rotated for five complete turns counterclockwise (looking at the face of the dial) and further until the zero on the dial is vertically upwards. The handle shall then be latched in this position. The load shall be removed while the wire is held in position, and the wire shall then be cut about 25 mm beyond the end of the fifth turn. This end of the wire shall be bent into a vertical position in line with the dial zero to act as a pointer.

A pencil or similar tool shall be placed to the left of this end of the wire to prevent any sudden springback. The coil shall then be allowed to unwind slowly and without jerking.

NOTE If the wire springs back suddenly, it is possible to obtain erroneous results.

The mandrel and the dial shall then be unlatched and rotated clockwise to bring the pointer back into a vertical position. The springback angle is equal to the reading on the dial in line with the pointer. With very springy wires, the pointer may recoil more than one complete revolution. If this is the case, 72 shall be added to the dial reading for each complete revolution of recoil.

Three specimens shall be tested. The three single values shall be reported. The mean value represents springiness.

5.3 Round wire with a nominal conductor diameter over 1,600 mm and rectangular wire

5.3.1 Principle

A straight piece of wire shall be bent through an angle of 30°. After removing the force, the reading of the angle by which the wire springs back is the measure of springiness.

5.3.2 Equipment

Figure 3 shows an example of the test equipment basically consisting of two jaws, one of which is fixed (2) and one is movable (1), and a sector graduated in degrees (5) with the 0° to 10° sector of the scale graduated in 0,5° increments. The graduated sector is an arc placed in a plane at 90° to the clamp faces. Its centre is located at the outer edge of the fixed jaw (3). The lever arm with its fulcrum placed at the centre of the arc can move over the graduated sector in the vertical plane.

The lever arm shall have a pointer or marker to provide a proper reading of the springback angle. On the lever arm with approximately 305 mm length scaled off in millimetres with the origin at the centre of the arc, is a slider (4) with a knife edge.

Dimensions in millimetres

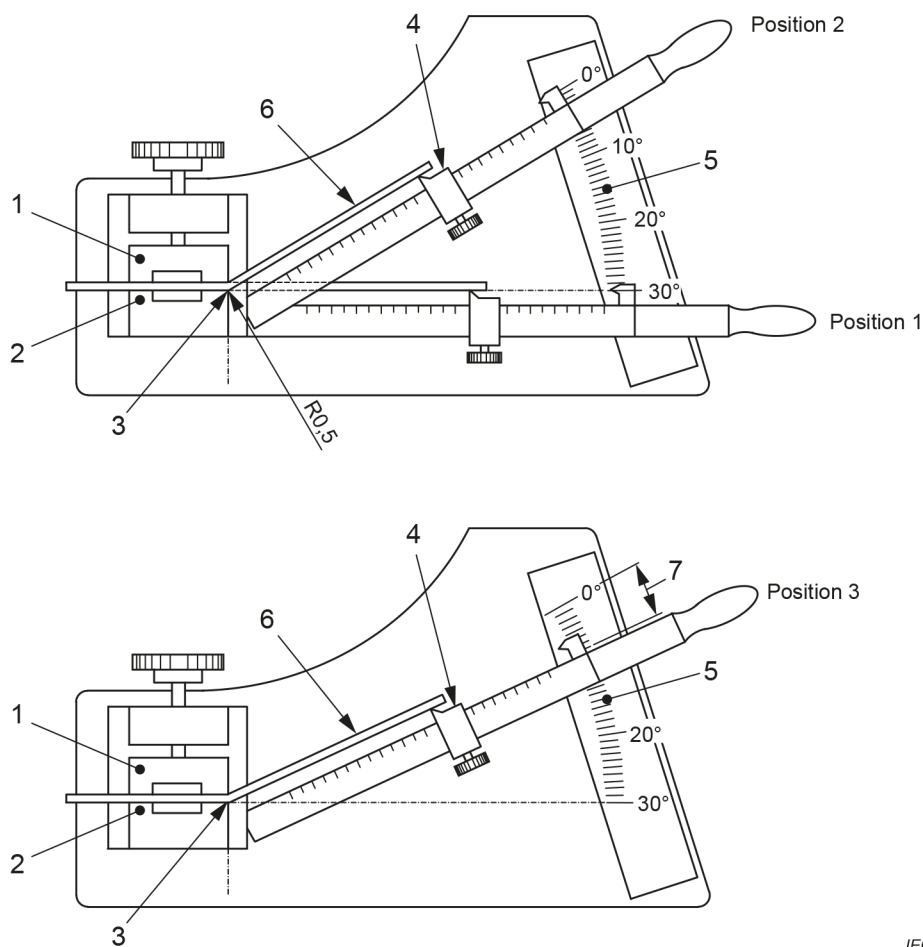

IEC

Key

- 1 moveable jaw
- 2 fixed jaw
- 3 centre of graduated sector
- 4 slider
- 5 graduated sector
- 6 wire specimen
- 7 springback

Figure 3 – Test equipment to determine springiness

5.3.3 Specimen

A wire sample of at least 1 200 mm in length shall be removed from the spool with as little bending of the wire as possible. It shall be straightened by hand and cut into three pieces each of 400 mm length. Elongation by tools shall not be used. Unnecessary bending shall be avoided to minimize work hardening.

5.3.4 Procedure

The conductor diameter or thickness, multiplied by 40, determines the position of the slider on the lever arm. The specimen shall be tightened between the jaws with a force just sufficient to prevent slipping. The specimen shall be tightened in such a position as to allow bending the wire in the same direction as it was wound on the spool. The free end of the specimen shall exceed the slider knife edge by (12 ± 2) mm.

By means of the lever arm, starting at the initial position (the 30° scale mark, position 1), the wire shall be bent for 30° (the 0° scale mark, position 2). The total bending shall take between 2 s and 5 s. The specimen shall be held in this position for not more than 2 s and then returned in the reverse direction at the same angular rate at which it was bent, until the slider knife edge moves away from the wire specimen. The lever arm shall be raised again until the slider knife edge just contacts the wire specimen without bending it. In this position, the springback angle equals the reading on the scale of the graduated sector in line with the pointer on the lever arm (position 3).

Three specimens shall be tested. All three values shall be reported. The mean value represents springiness.

6 Test 8: Flexibility and adherence

6.1 General

Flexibility and adherence reflect the potential of the wire to withstand stretching, winding, bending or twisting without showing cracks or loss of adhesion of the insulation.

6.2 Mandrel winding test

6.2.1 Round wire

6.2.1.1 General

A straight piece of wire shall be wound for 10 continuous and adjacent turns around a polished mandrel of the diameter given in the relevant standard. The mandrel shall be rotated with a rate of 1 r/s to 3 r/s with a tension applied to the wire that is just sufficient to keep it in contact with the mandrel. Elongating or twisting the wire shall be avoided. Any suitable equipment shall be used.

6.2.1.2 Enamelled round wire with a nominal conductor diameter up to and including 1,600 mm

If the relevant standard calls for pre-stretching before winding, the wire shall be elongated according to Clause 4 to the specified percentage. After winding, the specimen shall be examined for cracks with the magnification as given in Table 2.

Table 2 – Magnification to detect cracks

Nominal conductor diameter mm		Magnification ^a
Over	Up to and including	
–	0,040	10 to 15 times
0,040	0,500	6 to 10 times
0,500	1,600	1 to 6 times

^a One times magnification expresses normal vision.

Three specimens shall be tested. Any cracks detected shall be reported.

6.2.1.3 Fibre covered round wire

After winding, the specimen shall be examined for exposure of the bare conductor with normal vision or with a magnification of up to six times.

Three specimens shall be tested. Exposure of the bare conductor shall be reported.

6.2.1.4 Fibre covered enamelled round wire

After winding, the specimen shall be examined for exposure of the bare conductor or underlying coating with normal vision or with a magnification of up to six times.

Three specimens shall be tested. Exposure of the bare conductor or the underlying coating shall be reported.

6.2.1.5 Tape wrapped round wire

After winding, the specimen shall be examined for exposure of the bare conductor or delamination with normal vision or with a magnification of up to six times.

Three specimens shall be tested. Exposure of the bare conductor or any delamination shall be reported.

6.2.2 Rectangular wire

A straight piece of wire approximately 400 mm in length shall be bent through 180° round a polished mandrel of the diameter given in the relevant standard in two directions to form an elongated S-shape. The straight part between the U-shape bends shall be at least 150 mm. Care should be taken to ensure that the specimen does not buckle or depart from a uniform bend. A suitable apparatus is shown in Figure 4.

After bending, the insulation shall be examined for cracks in the case of enamelled wire, for exposure of the bare conductor or underlying coating in the case of fibre covered wire and for exposure of the bare conductor and delamination in the case of tape wrapped wire under a magnification of six to ten times.

Six specimens shall be bent, three flatwise (on the thickness) and three edgewise (on the width). If the wire shows cracks or delamination, exposure of the bare conductor or underlying coating, whichever is applicable, this shall be reported.

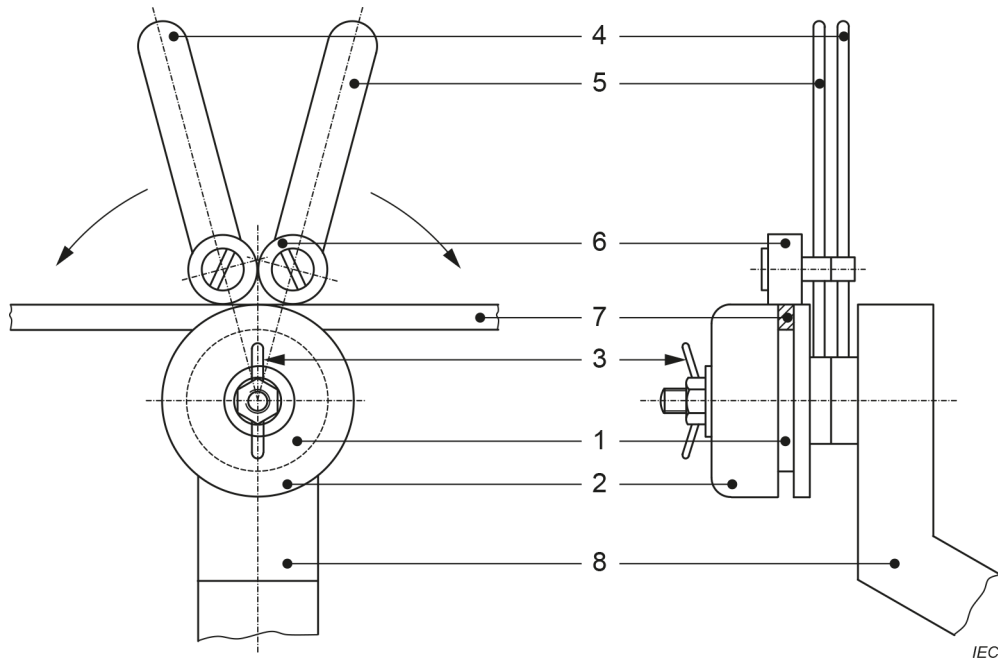

Key

- 1 mandrel
- 2 mandrel clamping collar
- 3 winding nut
- 4 lever
- 5 lever
- 6 ball bearing
- 7 specimen
- 8 support

Figure 4 – Test equipment for mandrel winding test

6.2.3 Covered bunched wire

A straight piece of wire shall be wound for ten continuous turns around a polished mandrel of the diameter given in the relevant standard and under a tension given in IEC 60851-2:2009, 3.2.5.3. Care should be taken not to twist the specimen for each revolution.

After winding, the specimen shall be examined by normal vision for openings in the covering.

One specimen shall be tested. If the wire does not show the required degree of closeness of the covering, this shall be reported.

6.3 Stretching test (applicable to enamelled round wire with a nominal conductor diameter over 1,600 mm)

A straight piece of wire shall be elongated according to Clause 4 to the percentage specified in the relevant standard. After elongation, the specimen shall be examined for cracks or loss of adhesion with normal vision or with a magnification of up to six times.

Three specimens shall be tested. If the wire shows cracks and/or loss of adhesion, this shall be reported.

6.4 Jerk test (applicable to enamelled round wire with a nominal conductor diameter up to and including 1,000 mm)

A straight piece of wire shall be rapidly stretched to the breaking point with test equipment as shown in Figure 5. A free measuring length of between 200 mm and 250 mm shall be provided. After stretching, the specimen shall be examined for cracks or loss of adhesion under a magnification as given in Table 2. A distance of 2 mm from the broken ends shall be disregarded.

Three specimens shall be tested. If the wire shows cracks and/or loss of adhesion, this shall be reported.

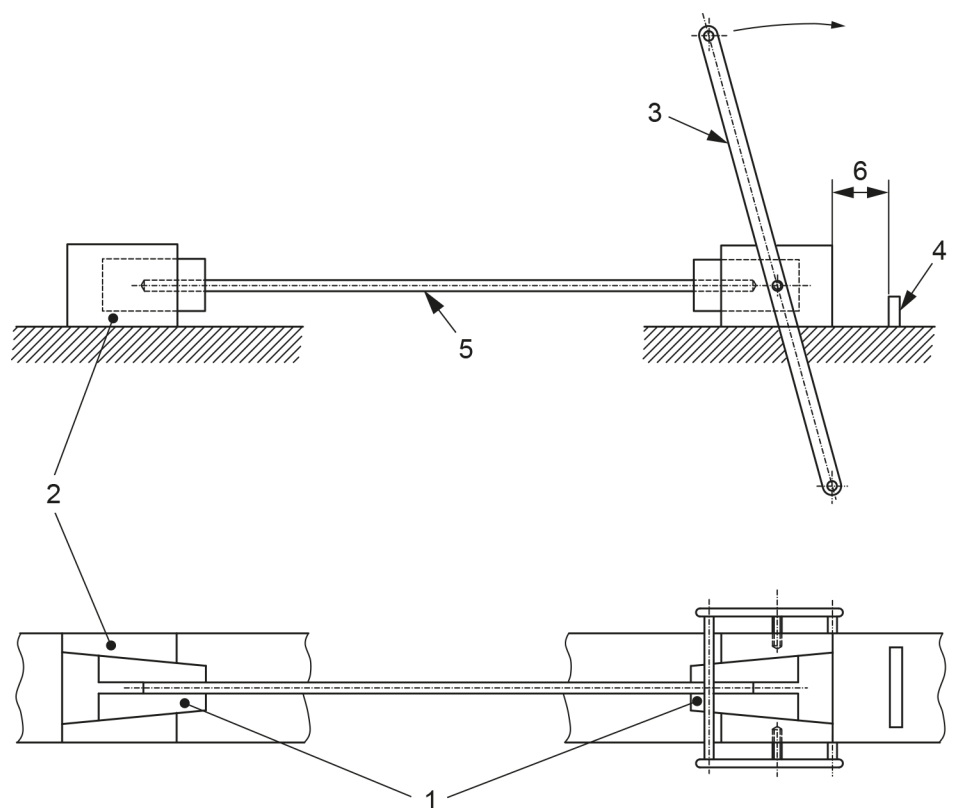

IEC

Key

- 1 wedge grips (clamps)
- 2 fixed jaw set
- 3 lever arm
- 4 adjustable stop
- 5 specimen
- 6 specified elongation

Figure 5 – Test equipment for jerk test

6.5 Peel test (applicable to enamelled round wire with a nominal conductor diameter over 1,000 mm)

A straight piece of wire shall be placed in the test equipment shown in Figure 6 consisting of two fixing devices 500 mm apart on the same axis. One of these is free to rotate. The other is not but can be displaced axially and is loaded according to Table 3 to apply a tension to the rotating wire.

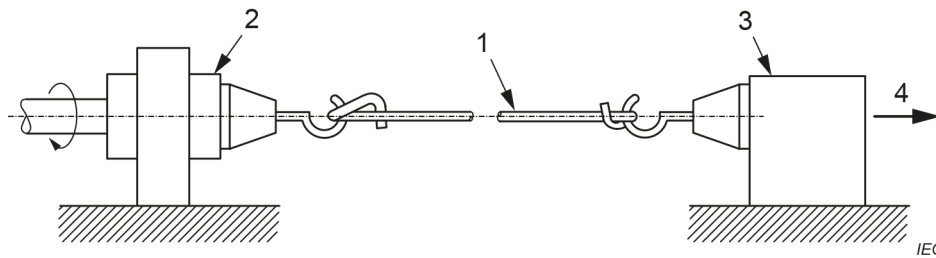

Key

- 1 specimen
- 2 rotary clamp
- 3 fixed clamp
- 4 load

Figure 6 – Test equipment for peel test

Table 3 – Load for peel test

Nominal conductor diameter mm		Load N
Over	Up to and including	
1,000	1,400	25
1,400	1,800	40
1,800	2,240	60
2,240	2,800	100
2,800	3,550	160
3,550	4,500	250
4,500	5,000	400

By means of a scraper as shown in Figure 7, the coating shall be removed on opposite sides of the wire and along the wire axis down to the bare conductor as shown in Figure 8. The pressure on the scraper shall be sufficient to remove the coating and leave a clean smooth surface at the coating/conductor interface without scraping off a significant quantity of conductor material. The removal of the coating shall commence about 10 mm from the fixing devices. The rotating device shall be driven at a speed of between 60 r/min and 100 r/min until the number of revolutions R as specified in the relevant standard has been reached.

After peeling and rotating, the specimen shall be examined for loss of adhesion. If the coating can be removed from the wire without difficulty (for example with the thumbnail), it shall be considered to have lost its adhesion even if it has not become completely detached from the wire.

One specimen shall be tested. If loss of adhesion is observed, this shall be reported.

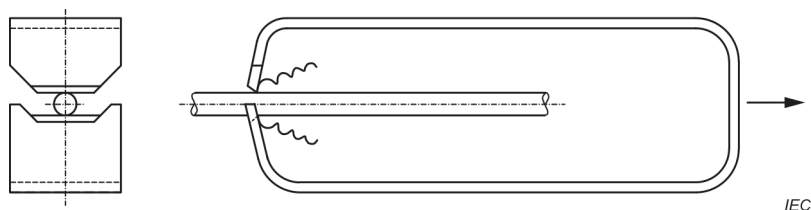

Figure 7 – Scraper

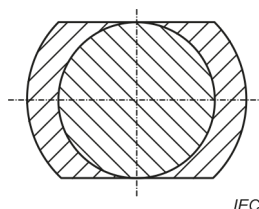

Figure 8 – Cross-section of the wire after removal of the coating

6.6 Adherence test

6.6.1 General

A straight piece of wire of about 300 mm length shall be elongated in accordance with Clause 4 to the percentage specified in the relevant standard.

6.6.2 Enamelled rectangular wire

Before elongation, the coating shall be cut circumferentially through to the conductor at a point approximately in the centre of the measured length. After elongation, the specimen shall be examined for loss of adhesion.

One specimen shall be tested. If loss of adhesion is observed, as determined by longitudinal measurement from the cut, it shall be reported. If so, the length of loss of adhesion shall be measured in one direction from the cut. The maximum value observed shall be reported after examining all sides of the specimen, under a magnification of six to ten times.

6.6.3 Impregnated fibre covered round and rectangular wire

Before elongation, the insulation shall be cut circumferentially at two places 100 mm apart in the centre of the wire specimen through to the conductor. After elongation, the specimen shall be examined for loss of adhesion under a magnification of six to ten times.

One specimen shall be tested. If loss of adhesion is observed according to the relevant specification, as determined by longitudinal measurement in one direction from the cut, it shall be reported. The maximum value observed shall be reported after examining all sides of the specimen, under a magnification of six to ten times.

6.6.4 Fibre covered enamelled round and rectangular wire

Before elongation, the insulation shall be cut circumferentially at two places 100 mm apart in the centre of the wire specimen through to the conductor. After elongation, the specimen shall be examined for loss of adhesion under a magnification of six to ten times.

One specimen shall be tested. If loss of adhesion is observed according to the relevant specification, as determined by longitudinal measurement in one direction from the cut, it shall be reported. The maximum value observed shall be reported after examining all sides of the specimen, under a magnification of six to ten times.

6.6.5 Tape-wrapped round and rectangular wire (for adhesive tape only)

Before elongation, the insulation shall be cut circumferentially through to the conductor at a point approximately in the centre of the measured length. After elongation, the specimen shall be examined for loss of adhesion under a magnification of six to ten times. One specimen shall be tested. The maximum value observed shall be reported after examining all sides of the specimen, under a magnification of six to ten times. If loss of adhesion is observed according to the relevant specification, as determined by longitudinal measurement in one direction from the cut, it shall be reported.

7 Test 11: Resistance to abrasion (applicable to enamelled round wire)

7.1 General

Resistance to abrasion is determined as the maximum force which can be sustained when a needle scrapes along the wire under a progressively increasing force.

7.2 Principle

A straight piece of wire is subjected to a unidirectional scrape test, by a needle to which a progressively increasing load is applied and which scrapes along the wire surface. The load that causes an electrical contact of the needle with the conductor is called the load-to-failure.

7.3 Equipment

Test equipment as shown in Figure 9 shall be used. It shall be provided with a mechanism to produce a scraping action in one direction at a rate of (400 ± 40) mm/min. The scraping device shall contain a polished piano wire or a needle of $(0,23 \pm 0,01)$ mm diameter, located between two jaws which hold the piano wire or needle rigidly, without sagging or curvature and at right angles to the direction of stroke which shall be in the direction of the axis of the wire under test. For placing the specimen, the test equipment shall be provided with two clamping jaws over a supporting anvil, which can be lowered while a wire is inserted into the jaws and straightened.

The test equipment shall provide a DC voltage of $(6,5 \pm 0,5)$ V to be applied between the conductor and the piano wire or the needle scraper. The short-circuit current shall be limited to 20 mA, for example by means of a series resistor or a relay. The circuit shall be designed to detect a short circuit and stop the equipment after the scraper is in contact with the conductor of the wire for about 3 mm.

The test equipment shall be provided with a graduated scale over the lower edge of the lever, which indicates the factor by which the initial load applied to the piano wire or to the needle has to be multiplied to determine the force-to-failure.

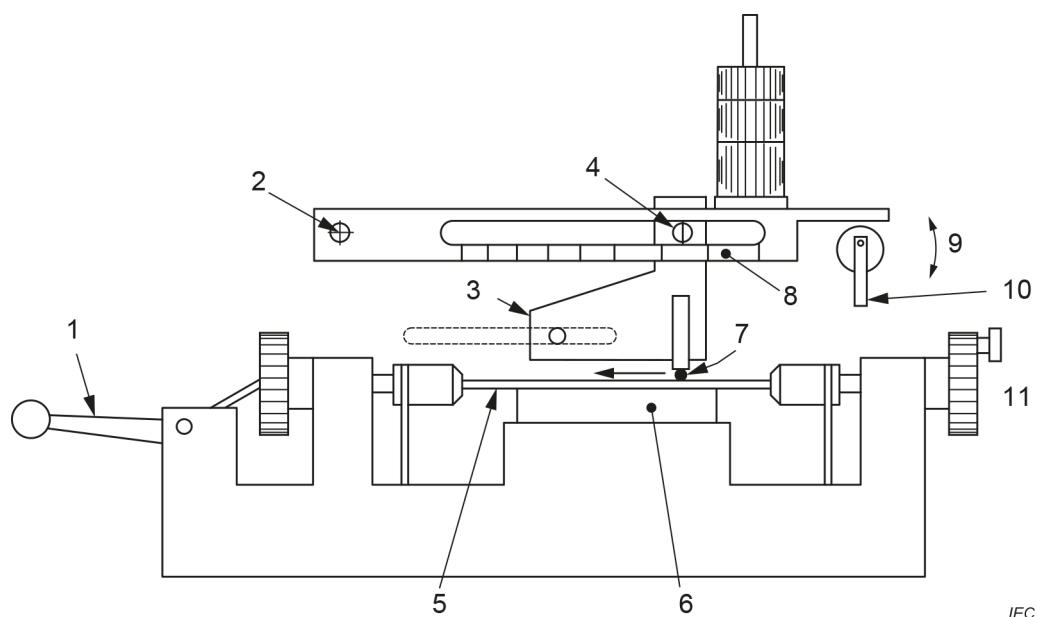

Weighted scraping device moves from right to left with increasing load on wire

Key

- 1 capstan for straightening specimen
- 2 fixed pivot point
- 3 weighted scraping device
- 4 indexer
- 5 specimen
- 6 anvil with adjustable height for wires with different diameters
- 7 piano wire
- 8 scale, indicating multiplying factor
- 9 reset/operate
- 10 reset lever
- 11 chucks index at 120° increments

Figure 9 – Test equipment for unidirectional scrape test

7.4 Procedure

A straight piece of wire shall be wiped clean, placed in the apparatus and straightened by a maximum of 1 % elongation. The specimen shall then be secured in the clamping jaws and the supporting anvil adjusted to contact the specimen. The initial force applied to the scraping device shall not exceed 90 % of the minimum force-to-failure specified in the relevant standard and shall lead to short circuit between scraper and conductor at a point between 200 mm and 150 mm from the fixed pivot point. The weighted scraping device shall be lowered slowly to the surface of the wire and the scraping action started.

The value at which the scraper stops shall be read on the graduated scale on the lower edge of the lever. The product of this value and the initial load applied shall be recorded.

The procedure shall be repeated twice on the same specimen, indexing around the periphery of the wire, once at 120° and once at 240° from the original position and the same information recorded.

One specimen shall be tested. The three single values shall be reported. The mean value represents the average force-to-failure.

8 Test 18: Heat bonding (applicable to enamelled round wire with a nominal conductor diameter over 0,050 mm up to and including 2,000 mm and to enamelled rectangular wire)

8.1 General

Heat bonding is the potential of the windings of a coil to bond together under the influence of heat.

8.2 Vertical bond retention of a helical coil

8.2.1 General

Vertical bond retention of a helical coil is the potential of the bonded coil to maintain its coherence when a load is applied to its lower end.

8.2.2 Nominal conductor diameter up to and including 0,050 mm

The method of test is to be agreed upon between purchaser and supplier.

8.2.3 Nominal conductor diameter over 0,050 mm up to and including 2,000 mm

8.2.3.1 Principle

The turns of a helical coil of the wire wound on a mandrel are pressed together by applying a load and then bonded by means of heat or solvent. After bonding, the specimen is removed from the mandrel and suspended in a vertical position with a load applied at the lower end to determine whether the specimen withstands a specified load or not. This procedure is repeated at an elevated temperature.

8.2.3.2 Specimen

A straight piece of wire shall be wound on a polished mandrel of a diameter according to Table 4. The coil shall have a minimum length of 20 mm. The winding rate shall be between 1 r/s and 3 r/s with an applied winding force not exceeding the values in Table 4. In order to allow the coil to relax freely, the ends of the wire shall not be fastened. A steel mandrel has been found to be satisfactory for larger diameter wires. For smaller wires, copper mandrels have been found to aid in the removal of the coil from the mandrel by stretching the mandrel to reduce its diameter.

The coil on the mandrel shall be positioned vertically as shown in Figure 10 a) with a load applied as specified in Table 4. The weight shall not stick to the mandrel, and there shall be a clearance between the weight and the mandrel. This arrangement shall then be placed in an oven with forced air circulation at a temperature specified in the relevant standard for a period of:

- 30 min for wires with a nominal conductor diameter up to and including 0,710 mm;
- 1 h for wires with a nominal conductor diameter over 0,710 mm up to and including 2,000 mm, unless otherwise agreed upon between purchaser and supplier.

After cooling to room temperature, the coil shall be removed from the mandrel.

8.2.3.3 Procedure at room temperature

A specimen shall be suspended by one of its ends (see Figure 10 b)) and loaded as required in the relevant standard. The load shall be applied in a way that avoids any additional shock.

Three specimens shall be tested. If turns other than the first and the last are separated, this shall be reported. The temperature for bonding the specimen shall be reported.

8.2.3.4 Procedure at elevated temperature

A specimen shall be suspended by one of its ends (see Figure 10 b)) and loaded as specified in Table 5. The load shall be applied in a way that avoids any additional shock. The specimen with its load shall be placed in an oven with forced air circulation for 15 min at a temperature as specified in the relevant standard.

Three specimens shall be tested. If turns other than the first and the last are separated, this shall be reported. The temperature for bonding the specimen shall be reported.

Table 4 – Preparation of helical coils

Nominal conductor diameter mm		Diameter of the mandrel mm	Maximum winding force N	Load on the coil during bonding N
Over	Up to and including			
0,050	0,071	1	0,05	0,05
0,071	0,100	1	0,05	0,05
0,100	0,160	1	0,12	0,15
0,160	0,200	1	0,30	0,25
0,200	0,315	2	0,80	0,35
0,315	0,400	3	0,80	0,50
0,400	0,500	4	2,00	0,75
0,500	0,630	5	2,00	1,25
0,630	0,710	6	5,00	1,75
0,710	0,800	7	5,00	2,00
0,800	0,900	8	5,00	2,50
0,900	1,000	9	5,00	3,25
1,000	1,120	10	12,00	4,00
1,120	1,250	11	12,00	4,50
1,250	1,400	12	12,00	5,50
1,400	1,600	14	12,00	6,50
1,600	1,800	16	30,00	8,00
1,800	2,000	18	30,00	10,00

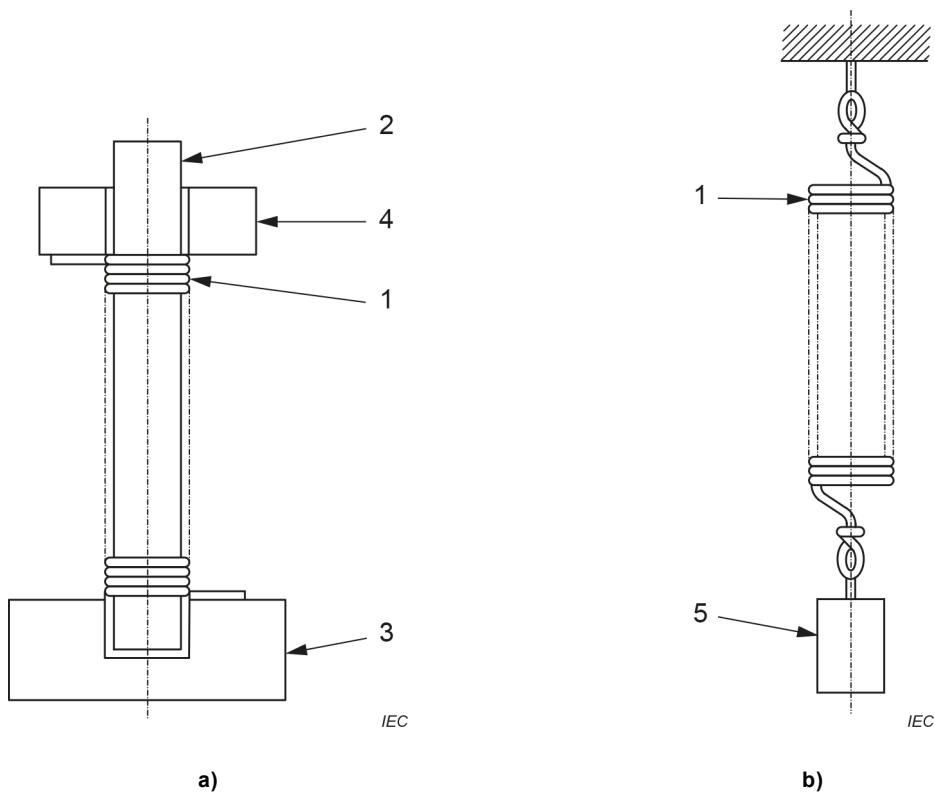

Key

- 1 coil
- 2 mandrel
- 3 mandrel-holder
- 4 weight
- 5 separating load

Figure 10 – Test equipment for bond retention of a helical coil

Table 5 – Bond retention at elevated temperature

Nominal conductor diameter mm		Load N	Nominal conductor diameter mm		Load N
Over	Up to and including		Over	Up to and including	
0,050	0,071	0,04	0,800	0,900	2,60
0,071	0,100	0,06	0,900	1,000	3,20
0,100	0,160	0,09	1,000	1,120	3,80
0,160	0,200	0,19	1,120	1,250	4,40
0,200	0,315	0,25	1,250	1,400	4,90
0,315	0,400	0,55	1,400	1,600	6,40
0,400	0,500	0,80	1,600	1,800	7,90
0,500	0,630	1,20	1,800	2,000	7,90
0,630	0,710	1,70			
0,710	0,800	2,10			

8.3 Bond strength of a twisted coil

8.3.1 General

Bond strength is the maximum force required to break the twisted coil.

8.3.2 Principle

A random wound coil prepared from the wire is formed to an oval shape, twisted and then bonded by applying a DC current. This specimen produces a rod, which is tested in tensile testing equipment in a horizontal position to obtain the maximum deflection force to break this rod. The test shall be repeated at elevated temperature.

NOTE This test is similar to method A, twisted coil test, given in IEC 61033:1991, 2.1 and IEC 61033:1991/AMD1:2006, 2.1, and is based on the same principle. It differs from method A of IEC 61033 with respect to twisting and bonding the specimen and with respect to wire sizes. It facilitates the testing of different wire sizes, whereas method A of IEC 61033 specifies that a wire of a nominal conductor diameter of 0,315 mm shall be used.

8.3.3 Equipment

The following equipment shall be used:

- coil winder in accordance with Figure 11 a) and Figure 11 b);
- coil twister in accordance with Figure 13;
- tensile test equipment in accordance with ISO 178 with a support complying with Figure 13;
- DC supply unit providing a constant current output with a capacity of minimum 50 V and 15 A;
- attached to the tensile test equipment, an oven with forced air circulation, which shall maintain the test temperature within a tolerance of ± 2 °C and which shall allow heating at least five specimens simultaneously within 5 min to 10 min to the test temperature.

8.3.4 Specimen

A random wound coil shall be prepared from the wire using winding equipment according to Figure 11 a) and Figure 11 b). The number of windings shall be calculated as

$$N = \frac{100 \times 0,315^2}{d^2}$$

where d is the nominal conductor diameter of the wire under test.

NOTE 1 For a nominal conductor diameter of $d = 0,315$ mm, N represents 100 turns. For other values of d , the above equation will lead to a number N , which gives the same total conductor cross-section as $N = 100$ and $d = 0,315$ mm.

To prevent opening of the coil after removal from the winding equipment, each end of the wire (or short pieces of enamelled wire) shall be wrapped around the coil two or three times at opposite positions. For this purpose, the winding equipment is provided with appropriate notches (see Figure 11 b)).

For winding the coil, the following dimensions shall apply:

- winding diameter: $(57 \pm 0,1)$ mm;
- width of slot: $(5 \pm 0,5)$ mm.

After removal from the winding equipment, the coil shall be formed to an oval shape (see Figure 12) and then twisted in a twisting device around its longitudinal axis according to Figure 13. This device allows application of a mechanical load to be applied to the coil while it

is twisted and subsequently bonded. This load shall be 100 N. The coil shall be twisted for two and a half turns and then half a turn in the reverse direction. While held under a mechanical load in the twisting device, the specimen shall be bonded by applying a constant DC current to the wire. A current shall be chosen that bonds the specimen within a period of 30 s to 60 s.

NOTE 2 Since DC current is used, it allows an easy approach to determine the average temperature of the specimen at the end of the heating period (see Annex A).

The specimen is a rod of about 7 mm in diameter and 85 mm to 90 mm in length.

Dimensions in millimetres

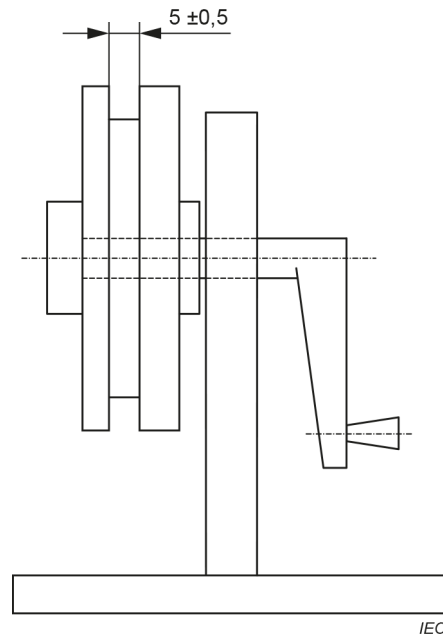

a) Coil winder

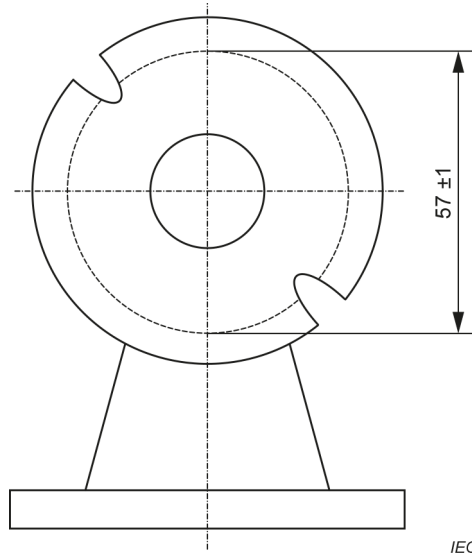

b) Coil winder, front view

Figure 11 – Coil winder



Figure 12 – Oval shape coil

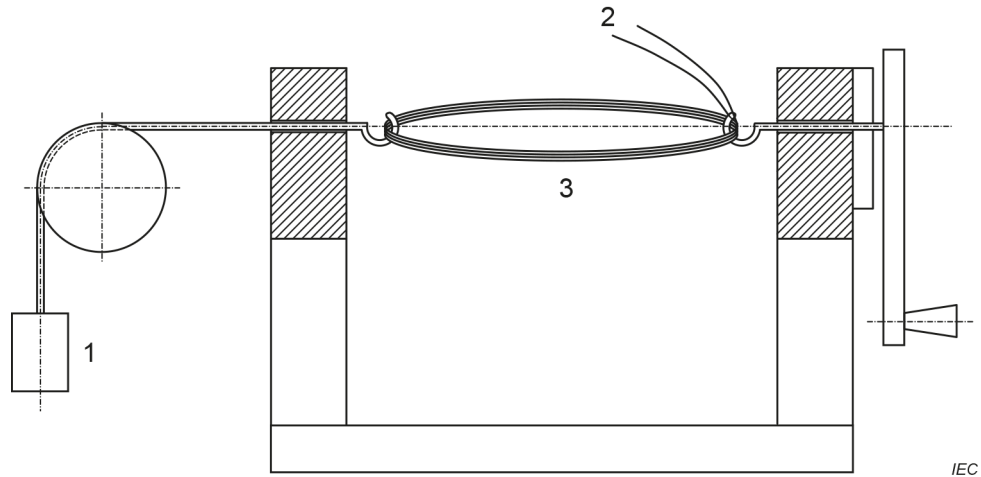

Key

- 1 load 100 N
- 2 DC current
- 3 twisted coil

Figure 13 – Twisting device with a load applied to the twisted coil specimen

8.3.5 Procedure

With the specimen properly positioned on a support according to Figure 14, the bond strength of the specimen shall be determined by adjusting the crosshead speed so that the maximum deflection force is reached in about 1 min.

For tests at elevated temperature, the specimen shall be placed in the oven preheated to the specified temperature. The specimen shall be tested after it has reached the oven temperature but not later than 15 min after being placed in the oven.

8.3.6 Result

For each temperature, five specimens shall be tested. The five single values shall be reported for each test temperature. The mean value represents the bond strength. The nominal conductor diameter, the number of turns of the coil and the bonding conditions of specimens shall also be reported.

Dimensions in millimetres

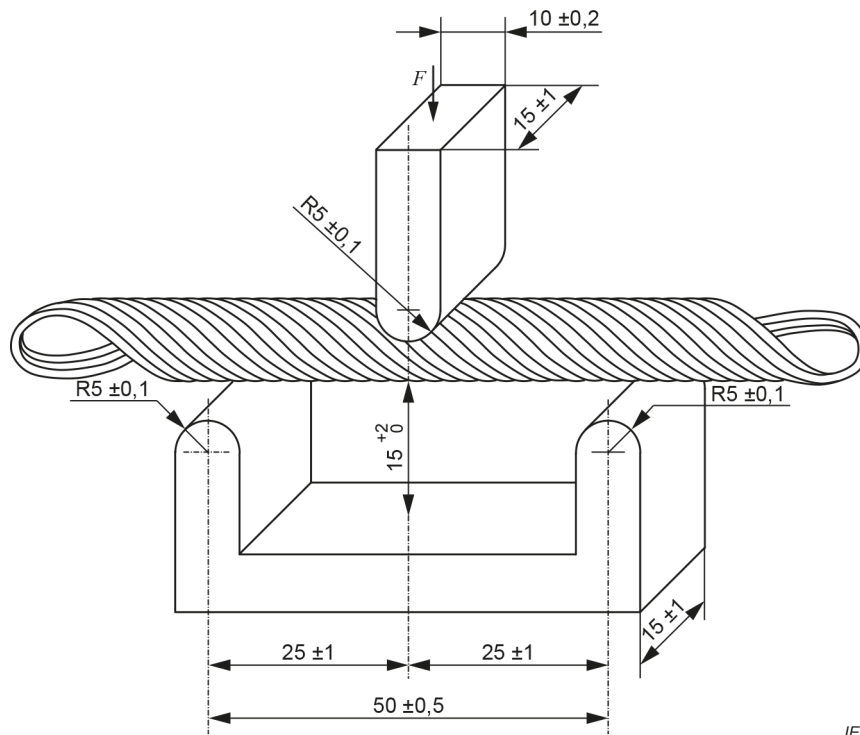

IEC

Figure 14 – Arrangement of supports

8.4 Enamelled rectangular wire heat bonding

Five specimens, each composed of two straight pieces of wire of about 100 mm length, are prepared according to Figure 15 and placed in a clamping device with an overlap length (L) (25 ± 5) mm under a pressure of 1,00 MPa. Other overlap lengths and clamping pressures may be agreed upon between user and supplier.

The total length of each specimen between jaws shall be about 125 mm.

The required load (P) for this pressure is calculated as:

$$P = 1,00 \times 25 \times (h - 2R)$$

where

R is the corner radius of the wire (mm);

h is the width of the wire.

The specimens shall be cured in an oven at $(120 \pm 2) ^\circ\text{C}$ for (24 to 24,5) h or as agreed upon between user and supplier.

After being cooled to ambient temperature, the specimens shall be subjected to a lap shear test by applying a gradually increasing load until detachment. The load shall be applied in a way that avoids any additional shock.

Shearing stress (MPa), which shall be as agreed upon between user and supplier, is calculated as:

$$T = \frac{F}{(h - 2 \times R) \times L}$$

where

F is the maximum measured force in N;

H is the width of the wire;

L is the overlap contact length between the wires;

R is the corner radius of the wire (mm);

T is the shearing stress.

The overlap length and the temperature for bonding the specimen shall be reported.

Dimensions in millimetres

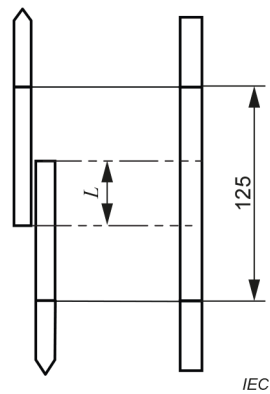

Figure 15 – Samples for heat bonding

Annex A (informative)

Bond strength of heat bonding wires

A.1 Calculation of the temperature of the twisted coil specimen

A.1.1 Method

While heating the twisted coil by means of DC current, the average temperature of the specimen may be derived from its DC resistance, which is the ratio of the voltage and the constant current applied. Such ratios can be determined at the beginning and at the end of any heating period and allow the calculation of the temperature at the end of the heating period.

A.1.2 Temperature coefficient

For the following calculations, a temperature coefficient of copper of $\alpha = 0,004 \text{ K}^{-1}$ is used.

A.1.3 Calculation

With this temperature coefficient, the resistance of the test specimen at the end of a heating period is calculated from the equation

$$R_{T_t} = R_{T_o} + \alpha R_{T_o} \times (T_t - T_o)$$

where

R_{T_o} is the resistance in the beginning (at room temperature);

T_t is the temperature at the end of the heating period;

T_o is the temperature at the beginning of the heating period (T_o is normally identical to room temperature, i.e., 23 °C).

Subscript t stands for the end of the heating period.

If the current is constant, the following equation applies:

$$\frac{R_{T_t}}{R_{T_o}} = \frac{U_t}{U_o}$$

where

U_t is the voltage at the end of the heating period;

U_o is the voltage at the beginning of the heating period.

This results in the temperature at the end of the heating period:

$$T_t = T_o + \left[250 \times \left(\frac{U_t}{U_o} - 1 \right) \right] \text{ in } ^\circ\text{C}$$

A.2 Determination of the heating period

A.2.1 Voltage-time graphs

While heating the twisted coil with a constant current, the electrical resistance increases with the temperature. To maintain the current, the voltage output of the constant current transformer increases accordingly. This allows plotting of DC voltage output against time. This provides information about the time t of the heating period. Different graphs may be taken for different currents all plotted on one and the same diagram.

A.2.2 Voltage at maximum temperature

In a specific case one might wish to bond the specimen up to a certain temperature, but not to exceed this temperature. If this maximum temperature is defined, the last equation as shown in A.1.3 allows the calculation of the voltage required to reach that temperature with a particular heating current:

$$U_t = U_o + 0,004 \times (T_t - T_o) U_o$$

The point of intersection of the voltage-time graph with the Y-axis corresponds to the value of U_o . With this reading, this equation allows the calculation of the voltage to arrive at the temperature of the specimen at the end of the heating period. The corresponding value of the X-axis gives the time length of the heating period required to reach the temperature T_t .

If the same calculation is done with all voltage-time graphs for one and the same temperature T_t , the corresponding entries may be used to produce an isothermic graph that intersects the voltage-time graphs. If this is repeated with different temperatures, it results in a final diagram, which is very helpful in selecting a suitable pair of values for the heating current in amperes and the time in seconds of the heating period to heat the test specimen up to the chosen temperature T_t .

Figure A.1 to Figure A.4 show examples of such complete diagrams for easy reference, based on wire sizes 0,300 mm, 0,315 mm, 0,355 mm and 0,500 mm respectively.

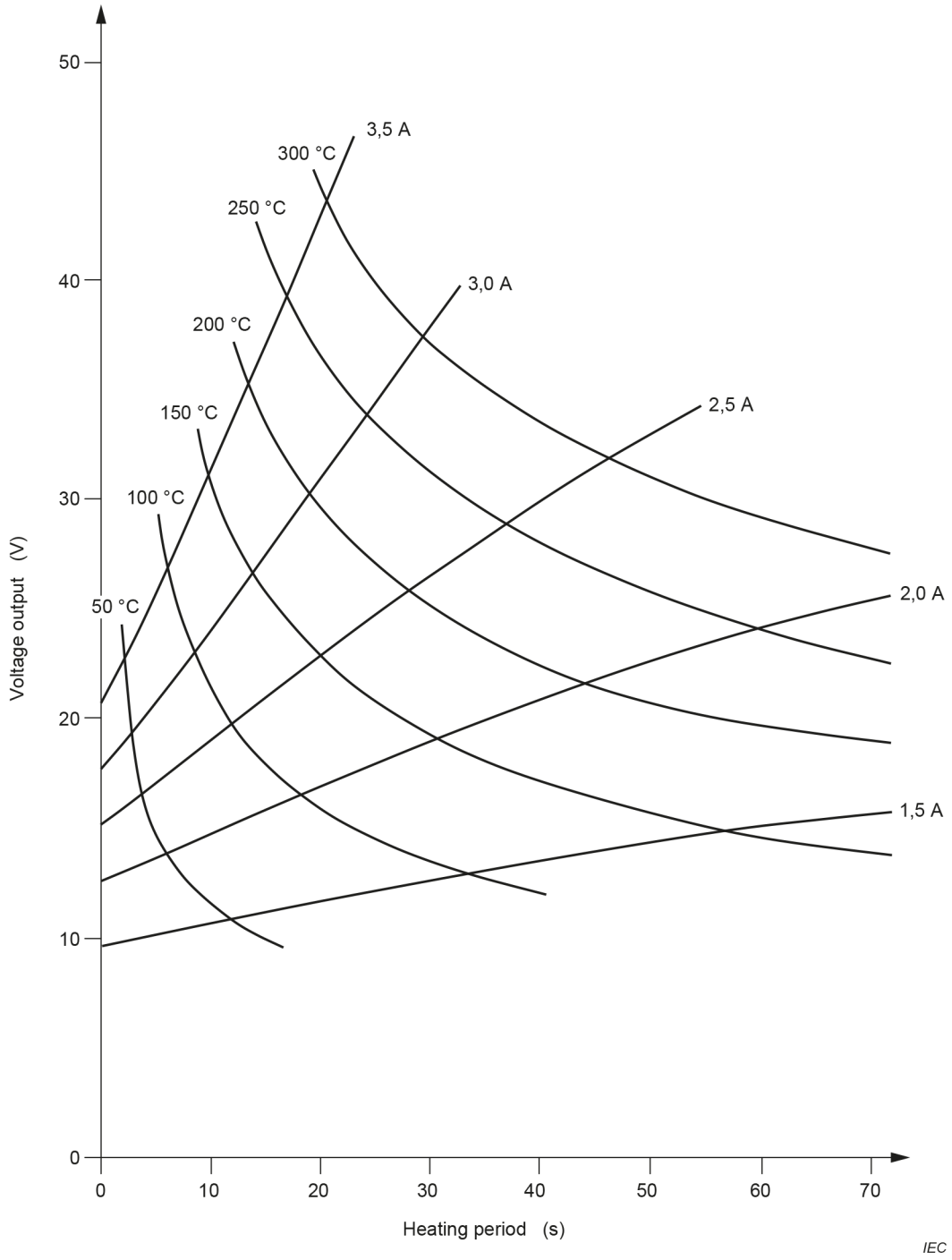

Figure A.1 – Example of voltage-time graphs of twisted coil specimens with a nominal conductor diameter of 0,300 mm with isothermic graphs

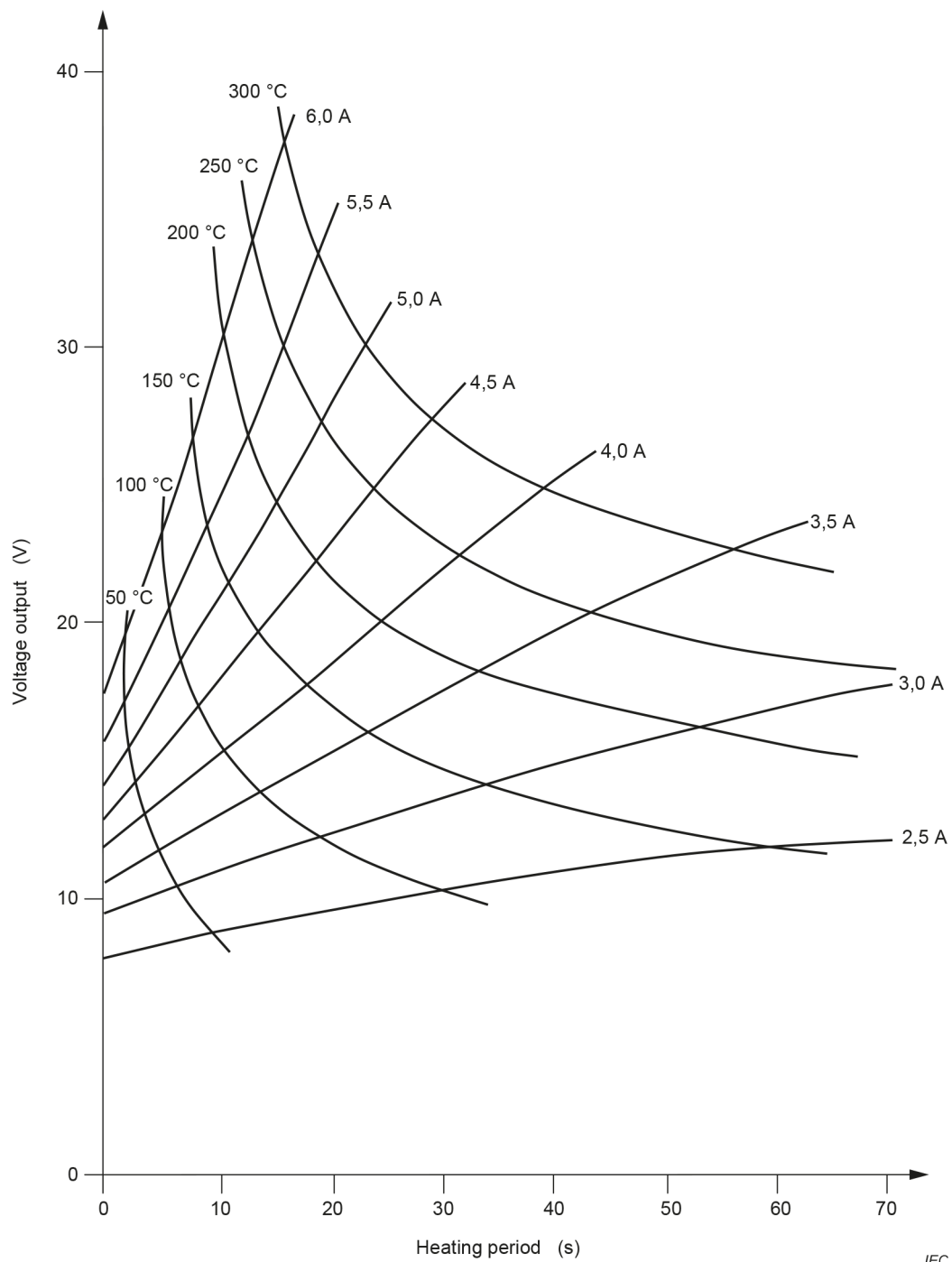

Figure A.2 – Example of voltage-time graphs of twisted coil specimens with a nominal conductor diameter of 0,315 mm with isothermic graphs

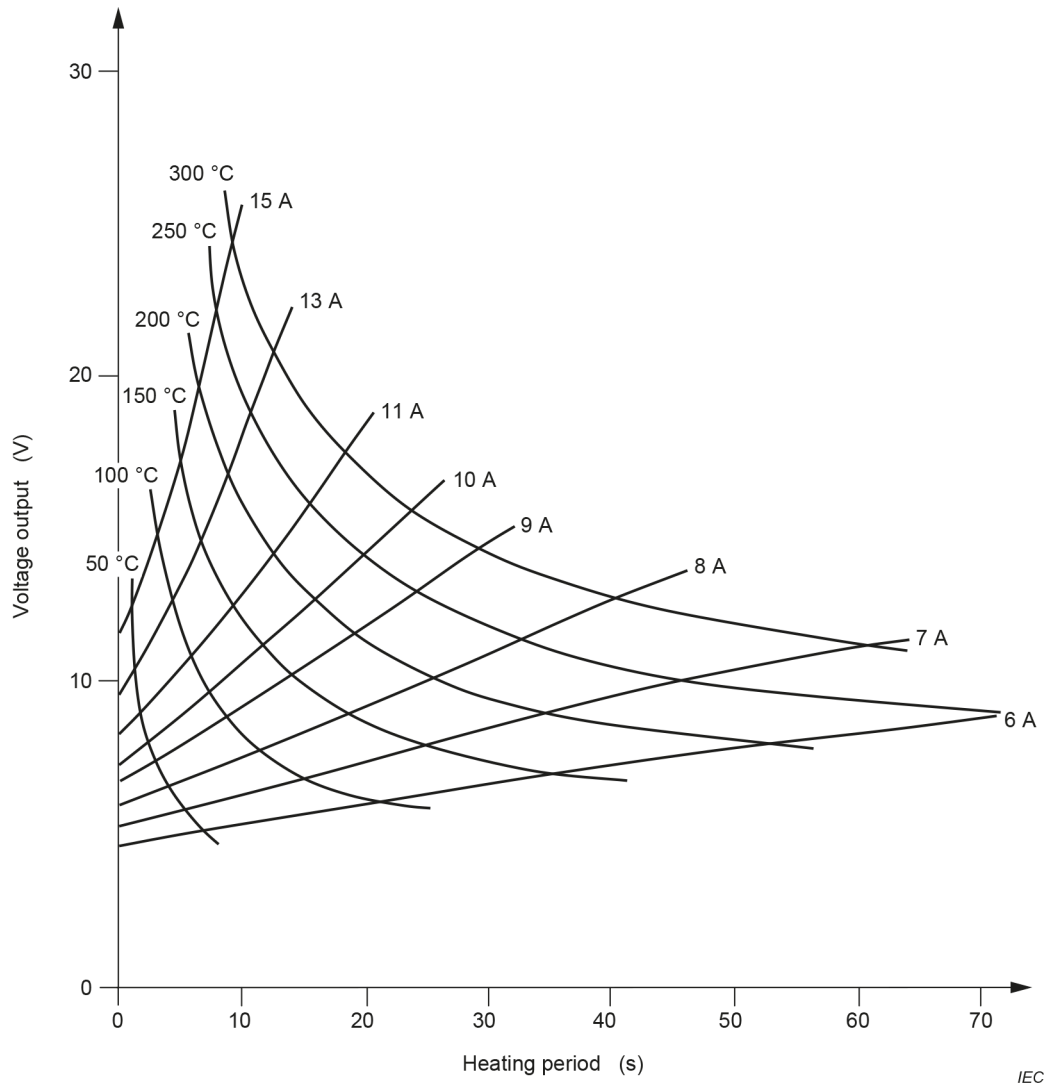

Figure A.3 – Example of voltage-time graphs of twisted coil specimens with a nominal conductor diameter of 0,355 mm with isothermic graphs

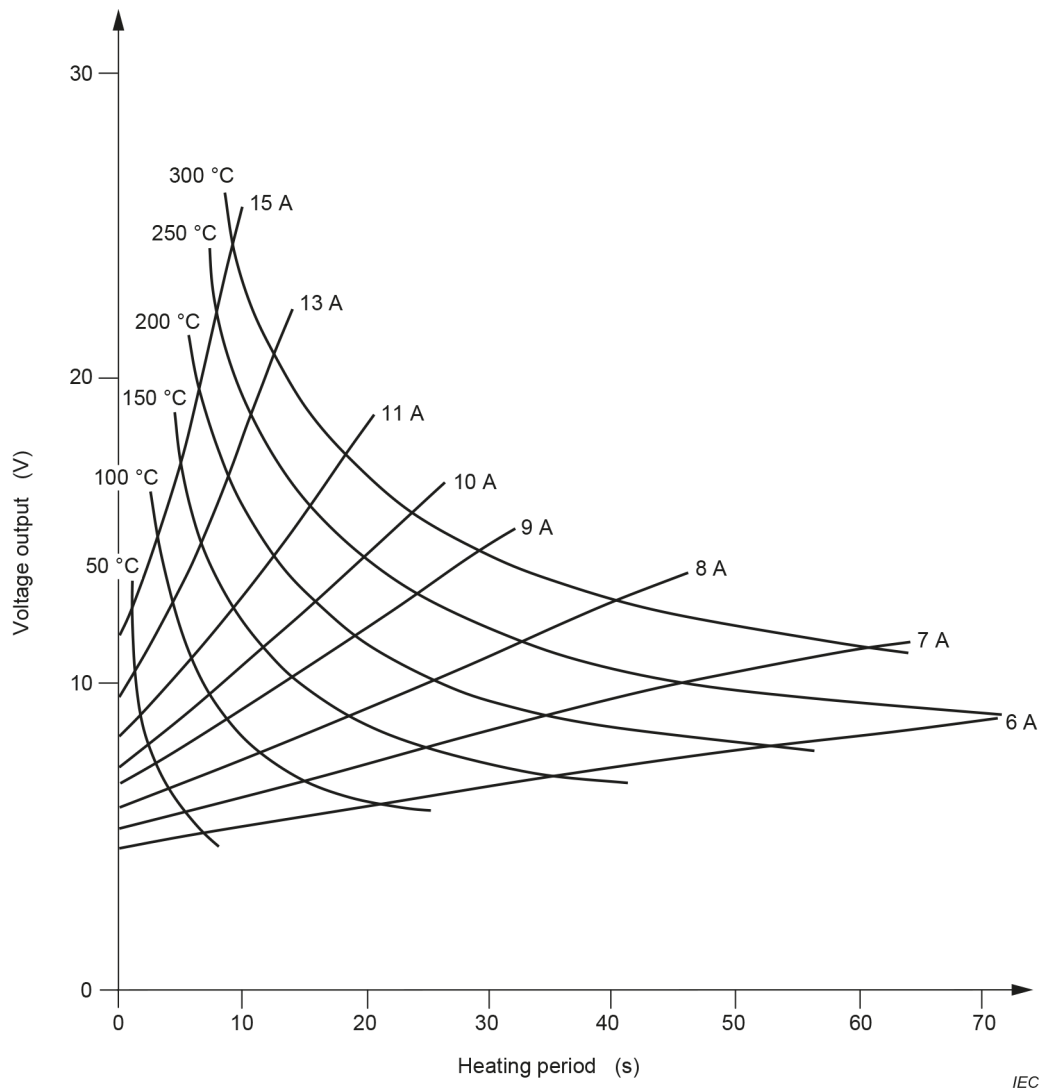

Figure A.4 – Example of voltage-time graphs of twisted coil specimens with a nominal conductor diameter of 0,500 mm with isothermic graphs

Annex B (informative)

Friction test methods

B.1 General

This annex provides recommendations to the purchaser and supplier of winding wires with respect to friction test methods to be used for winding wires. The use of additional methods can be agreed upon between purchaser and supplier.

B.2 Test A: Static coefficient of friction test method

B.2.1 Test method (applicable to enamelled round wires with a nominal conductor diameter from 0,050 mm up to and including 1,600 mm)

The static coefficient of friction (μ_s) is determined by measuring the inclining angle (α) of a plane at the moment when a block begins to slip on the track made from the wire specimen. The wire test specimen shall be removed from the delivery spools by de-reeling over the end flange. The top layers of the spool shall be removed before testing when the wire surface is contaminated by dirt or dust. One part of the wire specimen is straightened and then fixed on the inclining plane by means of the two posts and the two clamps constituting the sliding track. The other part of the wire specimen is mounted in a similar way on the sliding block.

The sliding block with the wire specimen is then placed on the track of the plane to be inclined in such a way that the wire on the block and the wire on the plane are crossed at right angles at the point of contact.

The plane is then slowly inclined (approximately 1°/s) until the block starts to slide down the track. At that moment, the angle of inclination (α) is read from the scale.

The static coefficient of friction is calculated as follows:

$$\mu_s = \tan \alpha$$

B.2.2 Test apparatus

The general arrangement of the test apparatus is shown in Figure B.1.

The apparatus consists of a plane (1), which can be inclined to an angle (α) by turning the plane around the axis (8). The support (9) carries a scale (7) marked with the inclination angle (α) or the coefficient of friction ($\tan \alpha$).

The plane has means for fixing the wire specimen (3), for example the two posts (5) and the two clamps (6). The parallel parts of the wire shall be 110 mm apart. The parallel parts form a sliding track running from the scale end to the axis on the plane.

On the block (2) clamps and posts are provided to fix the second wire specimen (4). The parallel parts of the specimen shall be 60 mm apart. It is critical that the size of the block allows the clamps and posts to stay clear of the plane (1) to avoid additional friction forces. The block shall have:

- a mass of about 50 g for a wire with a nominal conductor diameter up to and including 0,150 mm;
- a mass of about 500 g for a wire with a nominal conductor diameter over 0,150 mm.

The mass is not critical as it is nonetheless changed by the mass of the second wire specimen.

The angle of inclination shall be changed slowly by means of a motor-operated block and tackle.

B.3 Test B: First dynamic coefficient of friction test method

B.3.1 Principle

The coefficient of friction, μ_d , is determined by measuring the frictional force, C , applied on the wire when moving under the pressure of a known mass, E :

$$\mu_d = \frac{C}{9,81 \times E}$$

B.3.2 Method of test

The general arrangement of the test apparatus is shown in Figure B.2.

The enamelled wire runs via a guide wheel and a brake (4) over a metal plate (2). Via another guide wheel, the wire is lead below this plate (2) and runs back, parallel with the first passage, over this plate again (see Figure B.2). By means of a capstan (1), the wire is drawn with a speed of 0,25 m/s. A mass (5) is placed on the running wire over the plate (2), which is coupled to a force indication meter (3).

The force indication meter can be coupled to a linear recorder (measuring range 1 mV to 250 mV). This linear recorder shows the spread of the smoothness and the level of the wire smoothness over a long distance.

B.4 Test C: Second dynamic coefficient of friction test method (applicable to enamelled round wires with a nominal conductor diameter from 0,050 mm up to and including 1,600 mm)

B.4.1 Test equipment

The design of typical test equipment is illustrated in Figure B.3. Figure B.4 contains detailed drawings of synthetic sapphires and Figure B.5 is a photograph of the load block. The tester is supplied with a wire guiding system and a take-up which pulls the wire over the test bed at 15 m/min as shown in Figure B.6. The test block is aligned parallel with the test bed and the test weights are perpendicular to the wire specimen.

As the wire is pulled under the test block (synthetic sapphires), the friction between the wire surface and the sapphire surface develops a longitudinal force, which is transferred to the measuring system by a shaft supported by two sets of linear ball bearings in contact with the measuring system. The force indicated by the measuring system is divided by the load on the test surface to obtain the dynamic coefficient of friction.

The measuring system in Figure B.3 shows the dynamic coefficient of friction tester with a load cell in place to measure the force. A linear variable differential transformer (LVDT) may also be used to measure the force instead of a load cell. The electrical output from the force measurement device is fed into a computer or into a microprocessor that collects data measurements, usually 1 000 points. Statistics are performed on this data set so that proper interpretation of the results can be made.

NOTE 1 Values for the dynamic coefficient of friction are characteristic of the type of lubrication and the magnet wire specimen surface. The dynamic coefficient of friction values are generally not dependent on wire size.

NOTE 2 Wire lubricated with a mineral oil typically will have a mean dynamic coefficient of friction in the range of 0,9 to 0,16. Wire lubricated with a paraffin wax will typically have a mean dynamic coefficient of friction ranging from 0,03 to 0,06 and will be more consistent in value as evidenced by a lower standard deviation. The mean value, maximum value and standard deviation value can be used to evaluate the application of the lubricant to the wire and smoothness of the wire surface.

The test procedure is designed to provide a measure of the lubrication and the film surface smoothness as a combined value. It is assumed that the wire will be de-reeled from its packaging with minimal contact with surfaces other than those associated with the tester and packaging.

If it is suspected that the presence of dust or dirt may have an effect on the coefficient of friction, one or two outer layers of wire should be removed from the package and the sample retested.

Test surfaces in contact with the wire shall be clean and dry at the start of each separate test. The solvent used to clean the test load surface should remove the various types of lubricants used and should dry without leaving a film residue.

B.4.2 Test specimen

The surface of the wire should be examined for damage, tangles, or excessive dust or dirt. If any of these conditions are present, the top wire specimen layer of the spool should be surfaced off before testing. The wire test specimen should be removed from the shipping package by de-reeling over the end flange or pulling the wire from a pail or drum.

B.4.3 Specimen preparation

The wire specimen is pulled over a test bed surface under a test load (L). A frictional force (F_d) is developed between the wire surfaces and transferred to an appropriate measuring device. The reading (F_d) in grams-force is divided by the test load (L) in grams-force to obtain the dynamic coefficient of friction μ_d .

$$\mu_d = \frac{F_d}{L}$$

A motor should pull the wire specimen at 15 m/min \pm 1,5 m/min across a smooth surface using a motor driven take-up.

Various load weights should be available that will provide 100 grams-force to 1 000 grams-force.

The test block should be comprised of two mounted synthetic sapphires that have a surface roughness of not more than 2,4 μm . The sapphires are described in Figure B.4 and are mounted in accordance with Figure B.5.

There should be a means to guide the wire and a means to maintain a slight tension if needed.

An electrical force measuring device or transducer measures the force due to friction. A force transducer with a range of 0 grams-force to 500 grams-force, a data storage device, and a microprocessor or computer to statistically analyse the data sets should be installed.

A mechanical dampening system consisting of a paddle and a container filled with oil may be used. The electrical signals from the load cell or LVDT can also be dampened electronically.

A cleaning solvent appropriate for dissolving the lubricant being tested should be used for cleaning the sapphires and metal surfaces between tests.

B.4.4 Procedure

The coefficient of friction tester should be level so that the only force being measured by the pressure transducer is that which is perpendicular to the load being applied and so that gravity is not a factor.

Calibrate the pressure transducer by setting the zero without any load and setting the span by hanging a weight of 100 g or a weight of 200 g. Remove the weight and the display should again read zero.

Enter the parameters of the test into the microprocessor or personal computer.

De-reel the wire from its packaging by pulling the wire over the flange, through the tensioning device, through the guides, and onto the take-up spindle.

Adjust the guide pulleys so that the wire is parallel with the test bed. Clean the test bed, any guide pulleys, and the sapphire surfaces with a suitable solvent.

Place the appropriate weight from Table B.1 onto the load block:

Table B.1 – Load block weights for dynamic coefficient of friction testing

Conductor diameter mm	Weight g
0,050 to 0,071	100
0,071 to 0,125	200
0,125 to 0,450	600
0,450 to 1,600	1 000

Adjust the test bed to make the test load parallel with the test surface. Turn the wire take up on and start collecting data after the setup is stable and aligned and continue until the desired number of data points has been stored.

Analyse the data for minimum reading, maximum reading, mean value, and standard deviation.

The dynamic coefficient of friction μ_d should be calculated as follows:

$$\mu_d = \frac{F_d}{L}$$

where

F_d is the force reading in grams force;

L is the test load in grams force.

B.5 Test D: Force of friction by the twisted pair method

B.5.1 Enamelled round wires with a nominal conductor diameter from 0,1 mm up to and including 1,500 mm

From an enamelled wire specimen, a twist is made similar to the one used for test 13 (breakdown voltage) in IEC 60851-5:2008, 4.3 and IEC 60851-1:2008/AMD1:2011, 4.3. The end of the first twist strand is attached to a fixed jaw and a force is applied to the opposite end of the second strand that has been kept free to slide by traction and without rotating, using for example a dynamometer. The force to separate the two strands is the sliding force.

B.5.2 Test method

A specimen of approximately 400 mm in length shall be twisted back on itself for a distance of 125 mm on an apparatus as shown in Figure B.7. The force (weight) applied to the wire pair while the wire pair is being twisted and the number of twists are given in Table B.2.

At the twisted end, the loop is cut in two separate places to obtain a maximum separation between these cut ends.

Any bending of the wires, at the cut end or at the other untwisted end, to ensure adequate separation between the wires, shall avoid sharp bends or damage to the insulation.

One end of one wire shall be attached firmly to a jaw, while at the opposite end of the other wire a force (weight) is applied to let that wire slide without any rotation. Three specimens shall be tested.

Table B.2 – Twisted pair method

Nominal conductor diameter mm		Force applied to wire pairs N	Number of twists per 125 mm
Over	Up to and including		
0,10	0,25	0,85	17
0,25	0,315	1,40	15
0,315	0,40	2,40	13
0,40	0,50	3,40	12
0,50	0,71	6,00	11
0,71	0,80	8,50	10
0,80	0,90	10,00	9
0,90	1,00	12,50	8
1,00	1,12	15,00	7
1,12	1,25	20,00	6
1,25	1,50	27,00	5

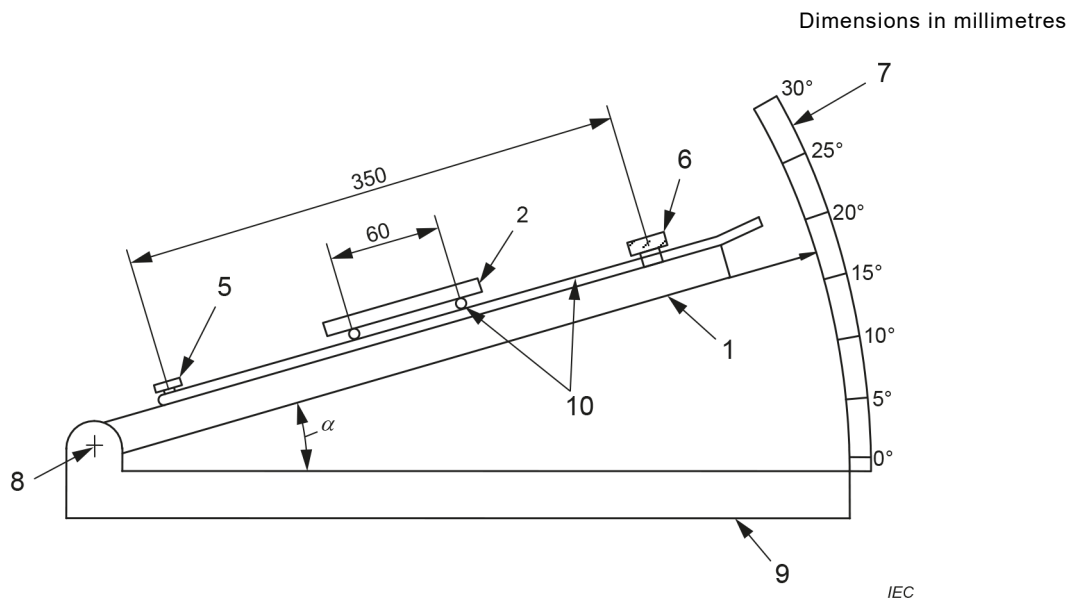

a) Side view

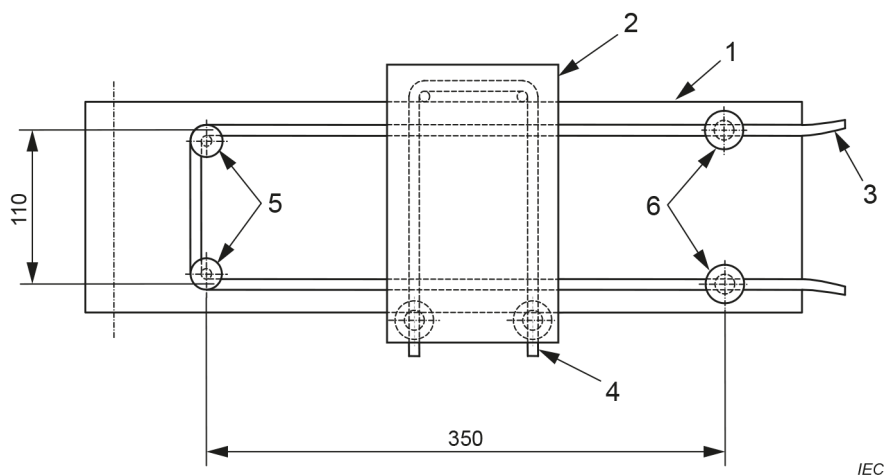

b) Top view

Key

- 1 plane
- 2 block
- 3 wire specimen
- 4 wire
- 5 posts
- 6 clamps
- 7 scale
- 8 axis
- 9 support
- 10 winding wire specimen

Figure B.1 – Static coefficient of friction test apparatus

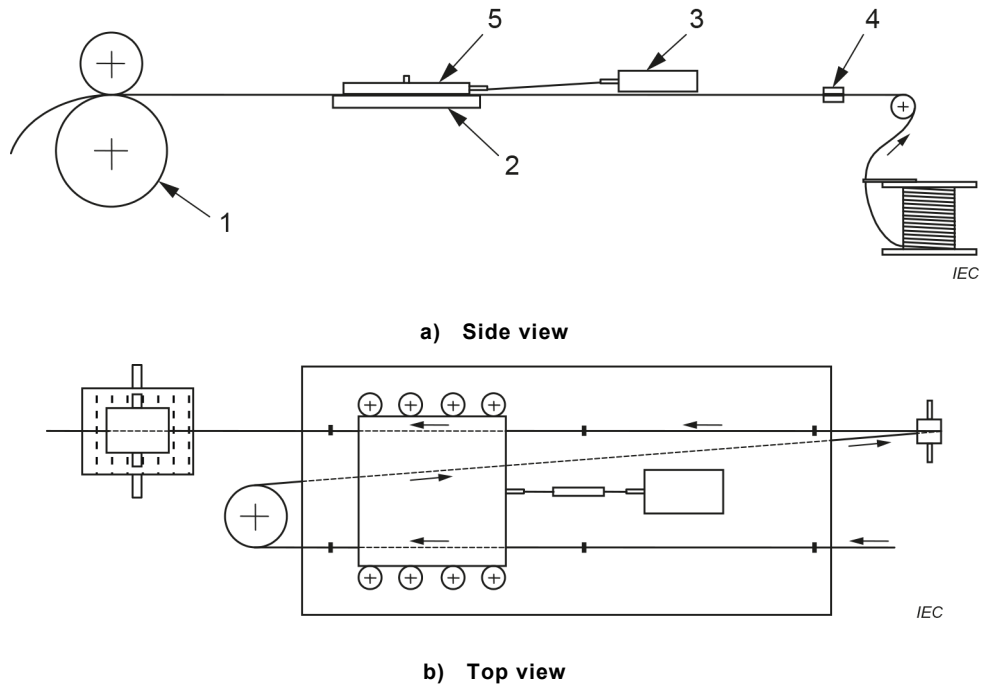

Components

- 1 capstan
- 2 plate
- 3 force indication meter
- 4 brake
- 5 mass

Figure B.2 – Dynamic coefficient of friction test apparatus

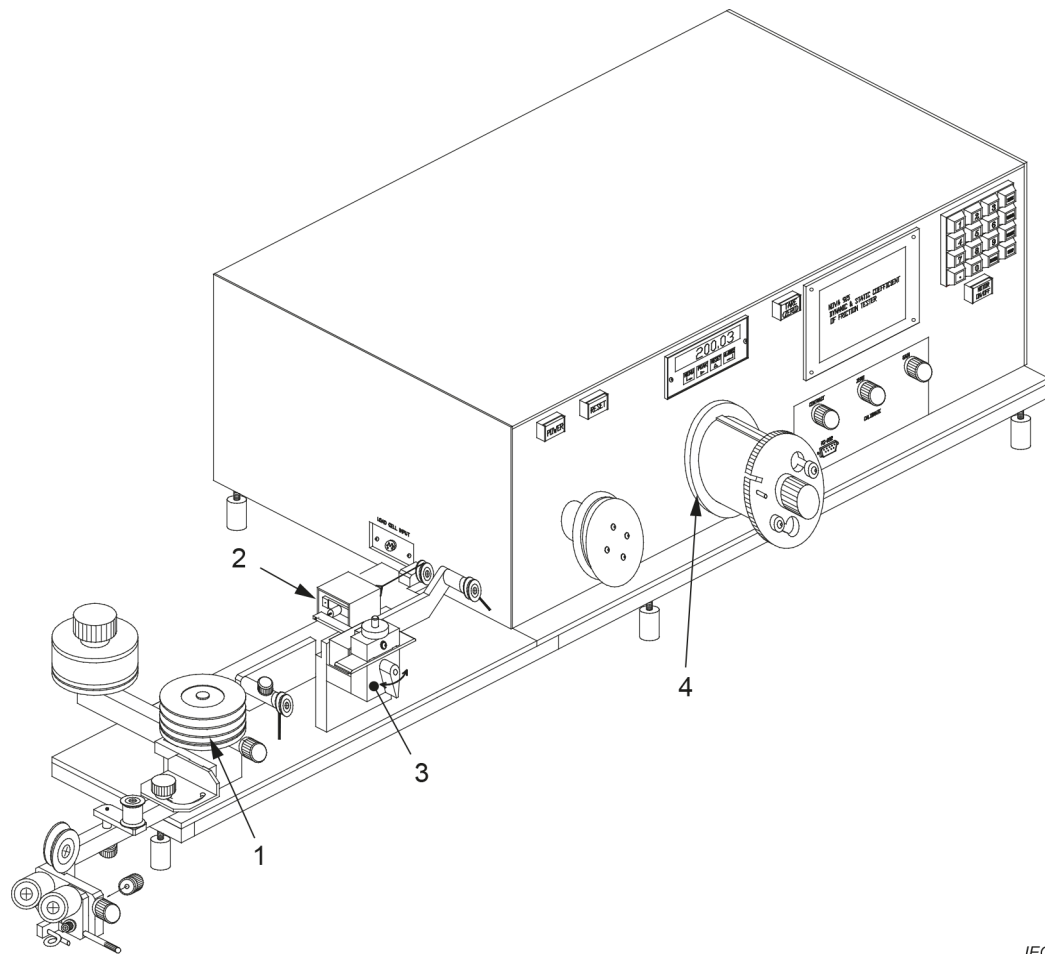

IEC

Key

- 1 wire tensioner
- 2 load cell assembly
- 3 sapphire test head and support block assembly
- 4 wire take-up mandrel

Figure B.3 – Diagram of a typical dynamic coefficient of friction tester

Dimensions in millimetres

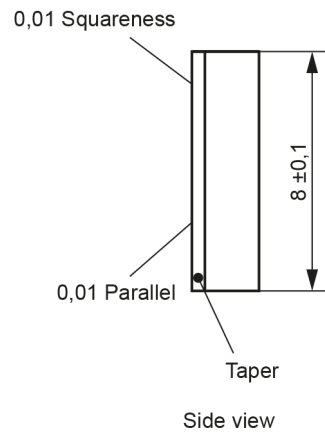
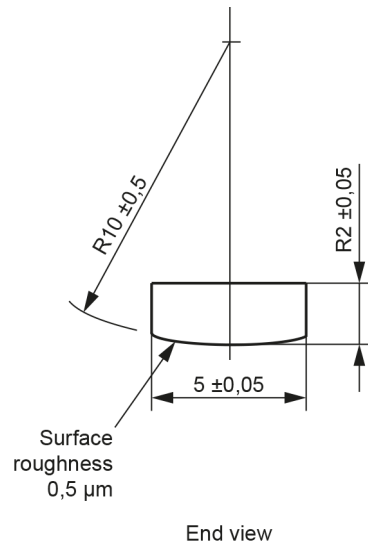

IEC

Figure B.4 – Material – sapphire (synthetic)

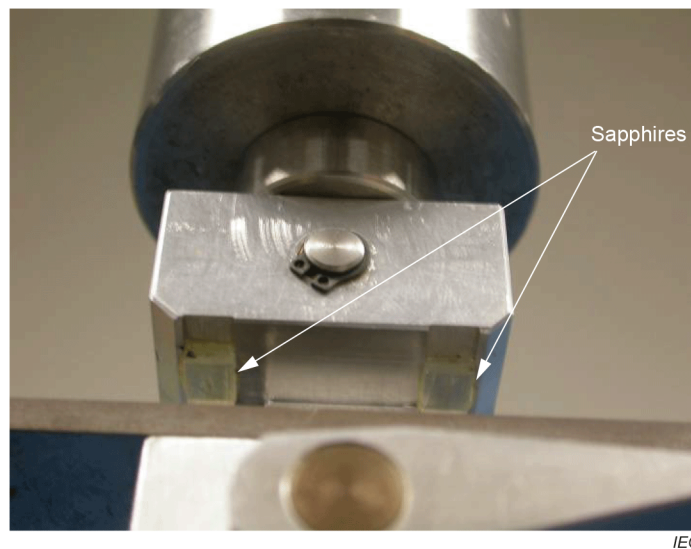

IEC

Figure B.5 – Synthetic sapphires mounted on load block

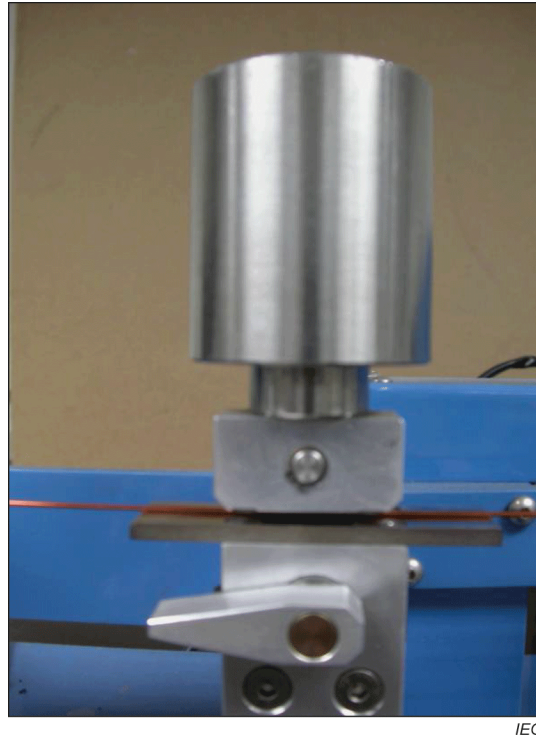

IEC

Figure B.6 – Load applied perpendicular to wire path

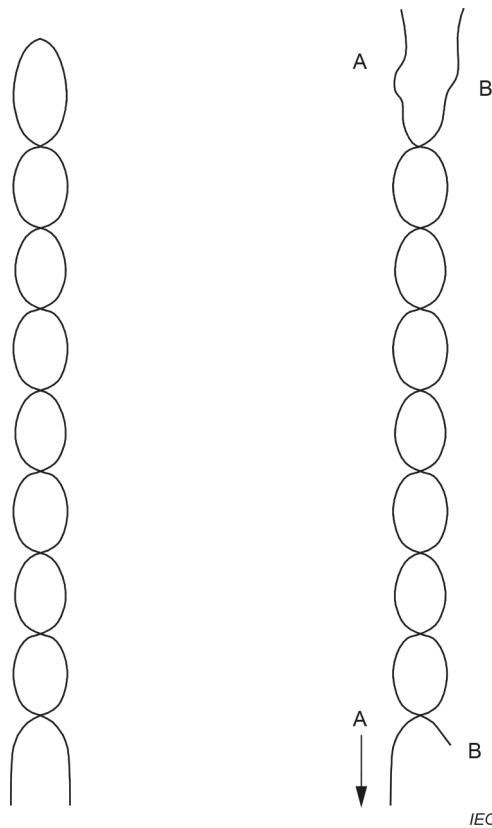

IEC

Figure B.7 – Twisted specimen

Bibliography

IEC 60264 (all parts), *Packaging of winding wires*

IEC 60317 (all parts), *Specifications for particular types of winding wires*

IEC 60851-1, *Winding wires – Test methods – Part 1: General*

IEC 60851-5:2008, *Winding wires – Test methods – Part 5: Electrical properties*

IEC 60851-5:2008/AMD1:2011

IEC 60851-5:2008/AMD2:2019

IEC 61033:1991, *Test methods for the determination of bond strength of impregnating agents to an enamelled wire substrate*

IEC 61033:1991/AMD1:2006

Bureau of Indian Standards

BIS is a statutory institution established under the *Bureau of Indian Standards Act, 2016* to promote harmonious development of the activities of standardization, marking and quality certification of goods and attending to connected matters in the country.

Copyright

BIS has the copyright of all its publications. No part of these publications may be reproduced in any form without the prior permission in writing of BIS. This does not preclude the free use, in the course of implementing the standard, of necessary details, such as symbols and sizes, type or grade designations. Enquiries relating to copyright be addressed to the Head (Publication & Sales), BIS.

Review of Indian Standards

Amendments are issued to standards as the need arises on the basis of comments. Standards are also reviewed periodically; a standard along with amendments is reaffirmed when such review indicates that no changes are needed; if the review indicates that changes are needed, it is taken up for revision. Users of Indian Standards should ascertain that they are in possession of the latest amendments or edition by referring to the website-www.bis.gov.in or www.standardsbis.in.

This Indian Standard has been developed from Doc No.: ETD 33 (25309).

Amendments Issued Since Publication

Amend No.	Date of Issue	Text Affected

BUREAU OF INDIAN STANDARDS

Headquarters:

Manak Bhavan, 9 Bahadur Shah Zafar Marg, New Delhi 110002

Telephones: 2323 0131, 2323 3375, 2323 9402

Website: www.bis.gov.in

Regional Offices:

	Telephones
Central : 601/A, Konnectus Tower -1, 6 th Floor, DMRC Building, Bhavbhuti Marg, New Delhi 110002	{ 2323 7617
Eastern : 8 th Floor, Plot No 7/7 & 7/8, CP Block, Sector V, Salt Lake, Kolkata, West Bengal 700091	{ 2367 0012 2320 9474
Northern : Plot No. 4-A, Sector 27-B, Madhya Marg, Chandigarh 160019	{ 265 9930
Southern : C.I.T. Campus, IV Cross Road, Taramani, Chennai 600113	{ 2254 1442 2254 1216
Western : 5 th Floor/ MTNL CETTM Technology Street, Hiranandani Gardens, Powai, Mumbai 400076	{ 2570 0030 2570 2715

Branches : AHMEDABAD, BENGALURU, BHOPAL, BHUBANESHWAR, CHANDIGARH, CHENNAI, COIMBATORE, DEHRADUN, DELHI, FARIDABAD, GHAZIABAD, GUWAHATI, HARYANA (CHANDIGARH), HUBLI, HYDERABAD, JAIPUR, JAMMU, JAMSHEDPUR, KOCHI, KOLKATA, LUCKNOW, MADURAI, MUMBAI, NAGPUR, NOIDA, PARWANOO, PATNA, PUNE, RAIPUR, RAJKOT, SURAT, VIJAYAWADA.