

निमज्जन पम्पसेटों के लिए लाइन  
संचालित ए.सी. मोटर — विशिष्टि  
( तीसरा पुनरीक्षण )

Line Operated a.c. Motors for  
Submersible Pumpsets —  
Specification  
( Third Revision )

ICS 23.100.10

© BIS 2024



भारतीय मानक ब्यूरो  
BUREAU OF INDIAN STANDARDS  
मानक भवन, 9 बहादुर शाह ज़फर मार्ग, नई दिल्ली - 110002  
MANAK BHAVAN, 9 BAHADUR SHAH ZAFAR MARG  
NEW DELHI - 110002  
[www.bis.gov.in](http://www.bis.gov.in) [www.standardsbis.in](http://www.standardsbis.in)

## FOREWORD

This Indian Standard (Third Revision) was adopted by the Bureau of Indian Standards, after the draft finalized by the Rotating Machinery Sectional Committee has been approved by the Electrotechnical Division Council.

This standard shall be read in conjunction with IS 8034 : 2018 'Submersible pumpsets — Specification (*third revision*)' and IS 14220 : 2018 'Open well submersible pumpsets — Specification (*first revision*)' as the submersible motor and the submersible pump together form a complete set. Coordination in the selection of motor and pump with respect to their size, rating and output, etc is necessary for satisfactory and efficient operation of the pumpset.

The general requirements of 3-phase induction motors are covered in IS 12615 : 2018 'Line operated three phase a.c. motors (IE code) "Efficiency classes and performance specification" (*third revision*)' and requirements of single phase a.c. motors are specified in IS 996 : 2009 'Single-phase a.c. induction motors for general purpose (*third revision*)'. The requirements of 3-phase squirrel cage induction motors for centrifugal pumps are covered in IS 7538: 1996 'Three-phase squirrel cage induction motors for centrifugal pumps for agricultural applications — Specification (*first revision*)'. The detailed procedure for conducting tests on motors are given in IS 4029 : 2010 'Guide for testing three phase induction motors (*first revision*)' and IS 7572 : 1974 'Guide for testing single-phase ac and universal motors' as relevant. In this revision the following have been added:

- a) Values of performance characteristics for 2-pole three-phase submersible motor — Oil filled (suitable for bore size 150 mm and maximum outside diameter of motor 146 mm);
- b) Five efficiency levels for 2-pole three-phase submersible motors (all performance characteristics tables);  
and
- c) Values of performance characteristics for submersible motor used in other applications.

Also, reference should be made to IS 10804 (Part 2) : 2018 'Recommended pumping systems for agricultural purposes: Part 2 Submersible pump sets (*third revision*)'.

The composition of the Committee responsible for the formulation of this standard is given in [Annex E](#).

For the purpose of deciding whether a particular requirement of this standard is complied with, the final value, observed or calculated, expressing the result of a test or analysis, shall be rounded off in accordance with IS 2 : 2022 'Rules for rounding off numerical values (*second revision*)'. The number of significant places retained in the rounded off value should be the same as that of the specified value in this standard.

*Indian Standard*

# LINE OPERATED a.c. MOTORS FOR SUBMERSIBLE PUMPSETS — SPECIFICATION

( *Third Revision* )**1 SCOPE**

This standard specifies technical requirements of submersible motors for submersible pumpsets commonly used in bore holes (bore-wells or tube wells) and submersible pumpsets commonly used in open wells for handling clear, cold and fresh water for application in agriculture, water supply, etc.

**2 REFERENCES**

The standards listed at [Annex A](#) contain provisions, which through reference in this text, constitute provisions of this standard. At the time of publication, the editions indicated were valid. All standards are subject to revision, and parties to agreements based on this standard are encouraged to investigate the possibility of applying the most recent editions of the standards.

**3 TERMINOLOGY**

For the purpose of this standard, the definitions given in IS 1885 (Part 35) and the following shall apply.

**3.1 Wet Type Water Filled Submersible Motors** —

It is a motor, which is completely filled with clear water (see [Fig. 1](#)).

**3.2 Wet Type Oil Filled Submersible Motors** —

It is a motor, where winding as well as entire remaining space within the motor is filled with non-toxic grade of oil and effectively sealed (see [Fig. 2](#)).

**3.3 Resin Filled Submersible Motors** —

It is a motor, where stator is encapsulated and filled with an insulating compound. The remaining portion is filled with water or oil (see [Fig. 3](#)).

**4 CHARACTERISTICS OF CLEAR, COLD AND FRESH WATER**

Clear, cold, and fresh water means water having the characteristics specified below:

- |              |                                   |
|--------------|-----------------------------------|
| a) Turbidity | 50 ppm (silica scale), <i>Max</i> |
| b) Chlorides | 500 ppm, <i>Max</i>               |

- |  |                            |
|--|----------------------------|
| c) Total solids                                      | : 3000 ppm, <i>Max</i>     |
| d) pH value  | : 6.5 to 8.5               |
| e) Temperature                                       | : 33 °C, <i>Max</i>        |
| f) Specific gravity                                  | : 1.004, <i>Max</i>        |
| g) Hardness (as CaCO <sub>3</sub> ) (drinking water) | : 300 mg/litre, <i>Max</i> |

NOTE — If any other characteristics of water differ from these specified in [4](#), the motor details shall be as agreed to between the manufacturer/supplier and the user and shall be specified in the order.

**5 CONSTRUCTION****5.1 General**

**5.1.1** The nomenclature of various components in the assembly of submersible motors is given in [Fig. 1](#) to [Fig. 3](#). The typical submersible pumpset installation is given in [Fig. 4](#) for information.

**5.1.2** All the materials and components for the motors shall be suitable for application in respect of corrosion resistance and mechanical performance continuously under water. The typical materials used in the submersible motors are given in [Table 1](#) for the guidance of the manufacturer and the user.

**5.1.3** The rotor of the wet type submersible motor shall be provided with suitable coating to protect it from corrosion under water.

**5.1.4** The motor shall be provided with a breathing attachment like bellows, diaphragm, etc to compensate the volumetric variation of water inside the motor due to changes in the temperature.

**5.2 Earthing**

**5.2.1** Motor shall have suitable provision for earthing to facilitate earthing of the motor as per [11.1](#) 'Protective earthing of machines' of IS 15999 (Part 1)/IEC 60034-1 at the time of installation.

**5.2.2** In case GI pipes are used for the purpose of earthing the motor, earthing connection may be made to the discharge pipe clamps.

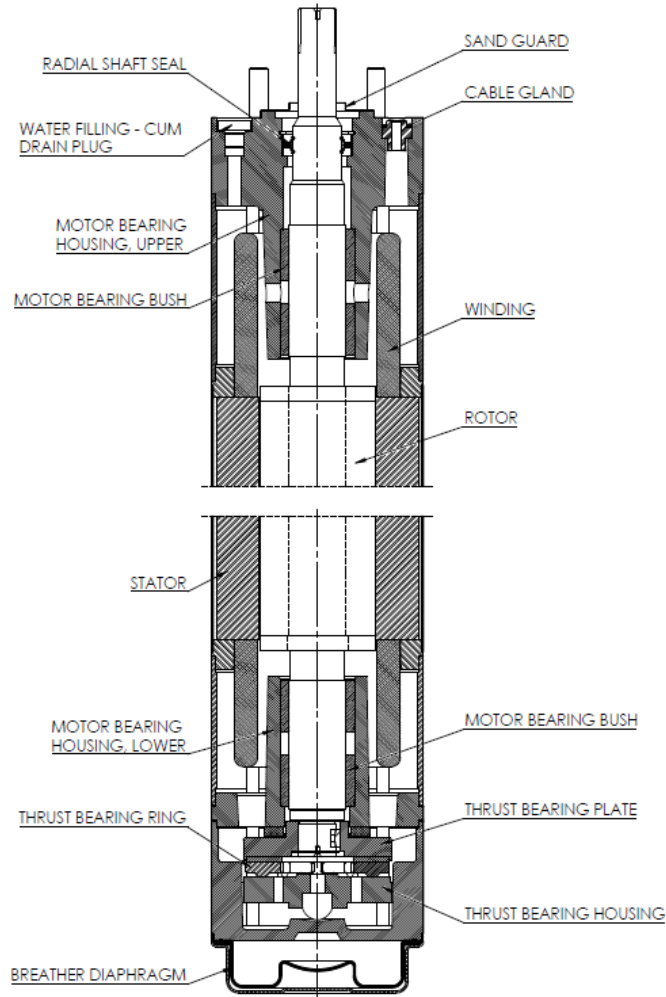

FIG. 1 WET TYPE WATER FILLED SUBMERSIBLE MOTOR

NOTE — This figure only illustrates the nomenclature of commonly used parts and does not specify any particular design feature. Earthing provision at suitable place may be given.

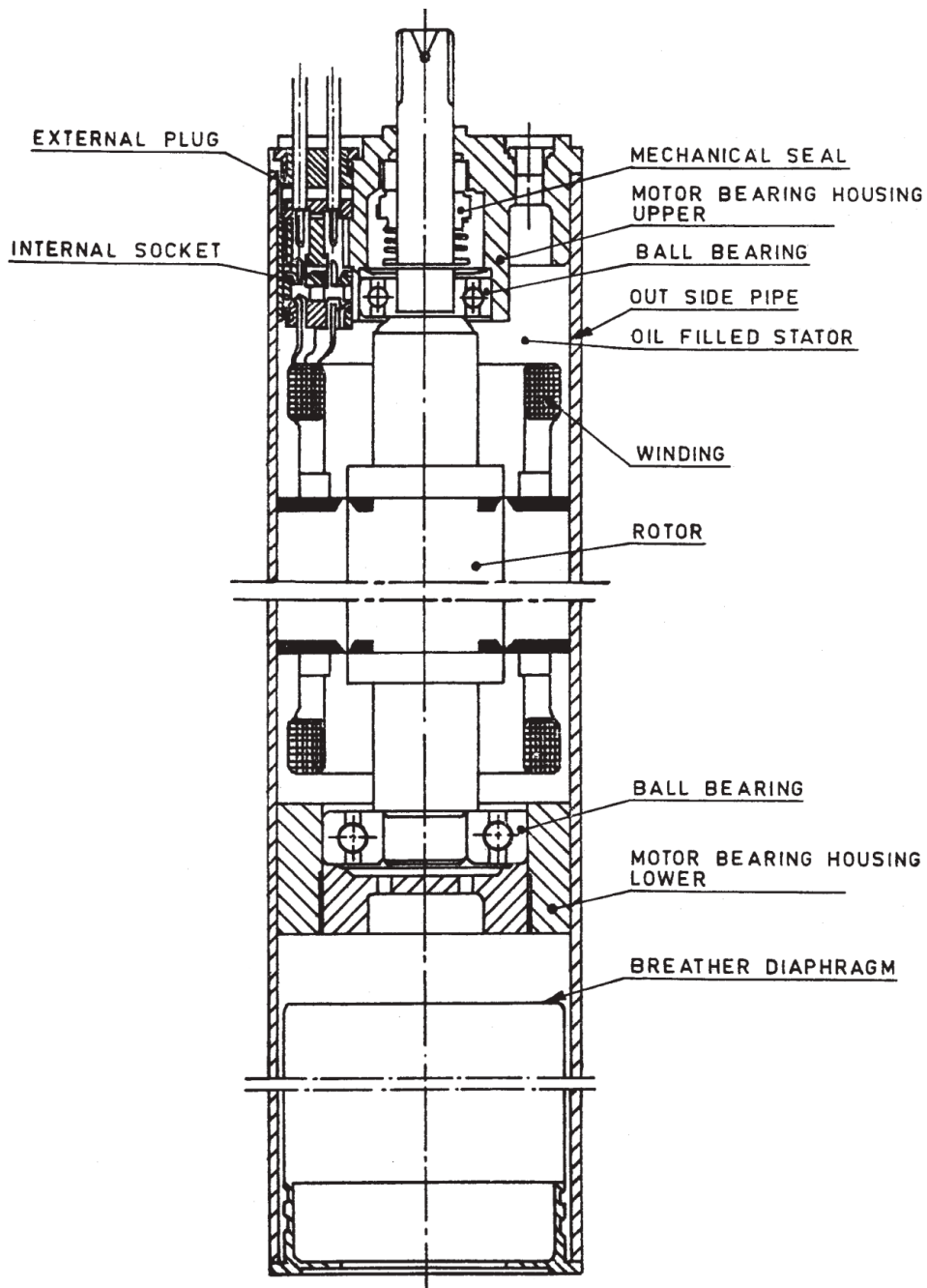

FIG. 2 WET TYPE OIL FILLED SUBMERSIBLE MOTOR

NOTE — This figure only illustrates the nomenclature of commonly used parts and does not specify any particular design feature.

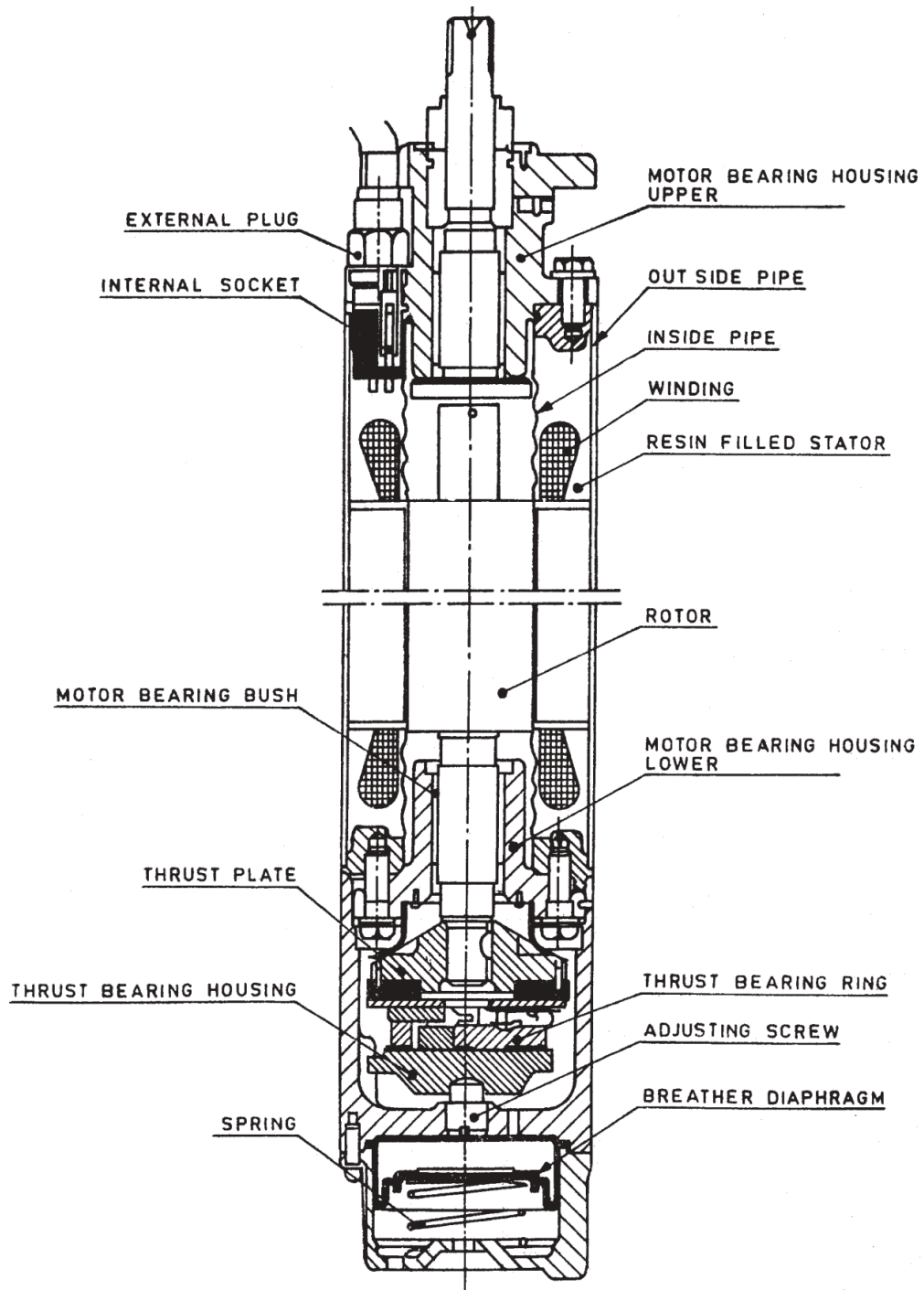

FIG. 3 RESIN FILLED SUBMERSIBLE MOTOR

NOTE — This figure only illustrates the nomenclature of commonly used parts and does not specify any particular design feature.

**5.3 Foreign Matter**

The motor shall be protected by means of cable glands, rubber seals, etc, from ingress of borewell water, sand and other foreign matter.

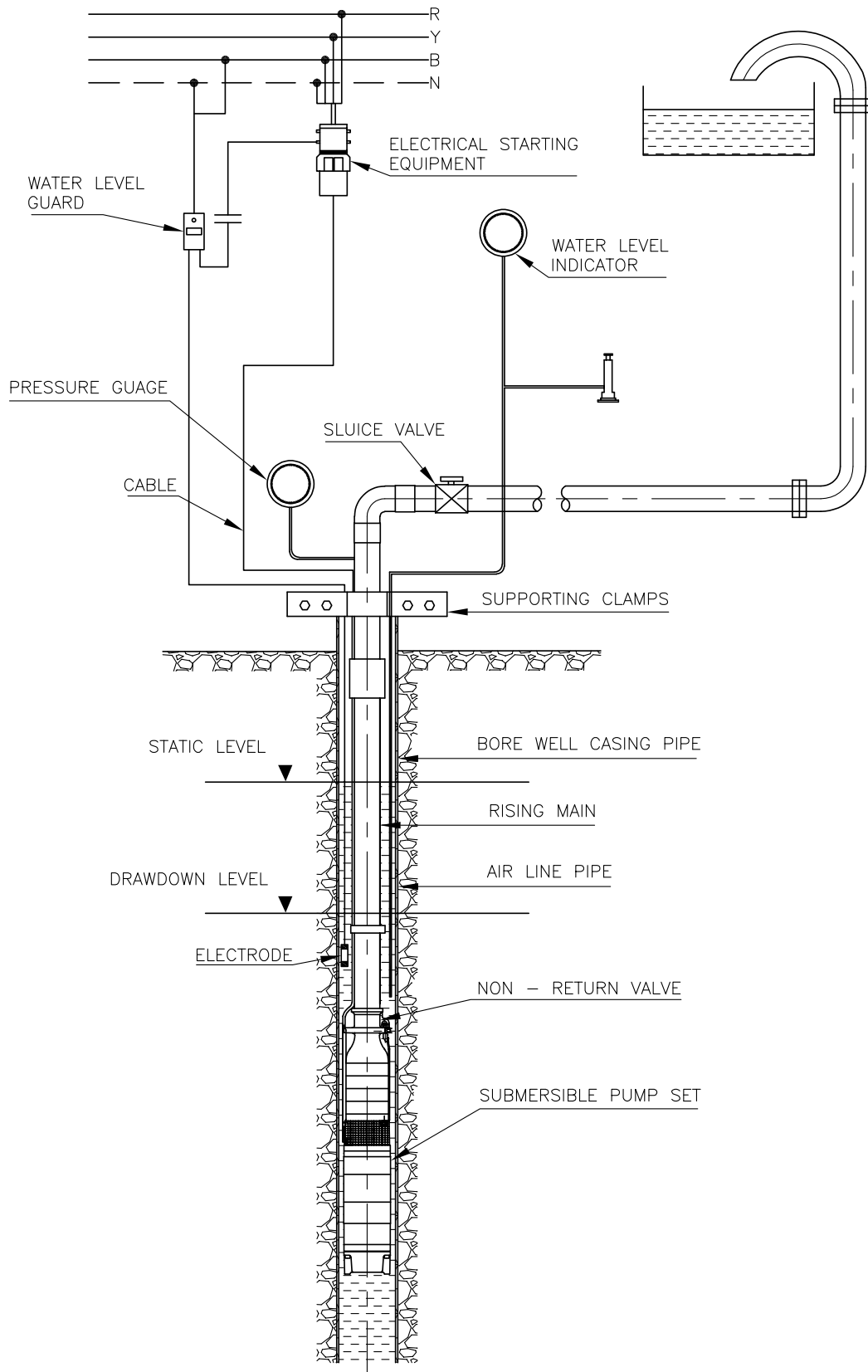

FIG. 4 TYPICAL SUBMERSIBLE PUMPSET INSTALLATION

**Table 1 Typical Materials for the Parts of the Submersible Motor**

(Clause 5.1.2)

SI No.	Name of the Part	Material	Indian Standard and Grade, If Any
(1)	(2)	(3)	(4)
i)	Bearing housing and base	Grey cast iron	IS 210 Gr FG 200
ii)	Motor shaft	Wrought steel or Chromium steel	IS 1873, C40  IS 1570 (Part 5) Gr 04 Cr 13, or 12 Cr 13, or 20 Cr 13
iii)	Bearing bush	Leaded tin bronze or resin bonded carbon metal-clad or rubber or rubber-lined	IS 318, LTB 3 or LTB 4 or LTB 5
iv)	Rotor:		
	a) Laminations	Electrical sheet steel electro grade copper or die cast	IS 648 IS 613
	b) Conductor core	aluminum	IS 4026
v)	Stator:		
	a) Lamination	Electrical sheet steel	IS 648
	b) Winding wire	Electro grade copper	IS 613
	1) Conductor		
	2) Insulation		
	i) For water filled motors	PVC or polywrap copper	IS 8783
	ii) For dry or encapsulated or oil filled or resin – filled motor	Conductor super enameled	Insulation details as covered in IS 13730 (Part 34)
vi)	Breather diaphragm	Nitrile rubber	-
vii)	Thrust bearing	Vulcanized fibre versus chromium steel or graphite versus graphite or vulcanized fibre versus bronze	-
viii)	Cable gland	Nitrile rubber	-
ix)	Cable:		IS 694
	a) Conductor	Electro grade copper PVC or with polymer and/or sheathing	
	b) Insulation		
x)	Stator casing	Grey cast iron or carbon steel (sheet or pipe) or stainless steel sheet	IS 210, FG 200 IS 1570 (Part 5) Gr 20 Cr 13

NOTE — Use of the materials containing hazardous substance like lead beyond permissible portion shall be phased out.



## 5.4 Recommendation for Selection of Submersible Cable

**5.4.1** The cable shall be insulated and sheathed with suitable polymer. It shall be flexible 3-core or 4-core flat type (or) with insulated leads. The requirements of the flat cable shall be as agreed between the manufacturer and the user. The size of the conductor shall be adequate and suitable for continuous use under water and in air. *See* Table 3 and Table 4 of IS 14536 for cable selection.

**5.4.2** The purchaser may specify the actual length of the cable required for the motor. In the absence of this information, the motor shall be supplied with a cable length of a minimum of 2 m.

**5.4.3** In case a joint is required to be made between the lead cable supplied with the motor and the user's cable, a detailed procedure to make a water tight jointing shall be supplied by the motor manufacturer. *See* 6.7 of IS 14536.

The size of the conductor and the length of cable should be suitably selected so that the voltage drop between the control panel and the motor terminals does not exceed three percent of the rated voltage. For details, *see* [Annex D](#).

## 5.5 Finish of Bearings

For motors having journal bearings, the surface of the rotor shaft or that of the sleeves when provided at the bearing portion shall have a surface roughness not higher than 0.75 microns Ra (*see* IS 3073).

## 5.6 Balancing of Rotor

The rotor shall be dynamically balanced as per grade given in 6.3 of IS/ISO 21940-11

## 6 PREFERRED VOLTAGE AND FREQUENCY

### 6.1 Preferred Voltage

The preferred rated voltage shall be 415 V for three-phase motors and 240 V for single-phase motors (*see* IS12360).

#### 6.1.1 Preferred Frequency

The preferred rated frequency shall be the standard frequency of 50 Hz.

### 6.2 Voltage and Frequency Variations

#### 6.2.1 Category 'A'

The motors shall be capable of delivering rated output with:

- a) terminal voltage differing from this rated value by not more than  $\pm 6$  percent;
- b) frequency differing from its rated value by not more than  $\pm 3$  percent; and

- c) any combination of (a) and (b).

#### 6.2.2 Category 'B'

The motor shall be capable of delivering rated output with:

- a) terminal voltage differing from this rated value by not more than + 6 percent and – 15 percent;
- b) frequency differing from its rated value by not more than  $\pm 3$  percent; and
- c) any combination of (a) and (b).

## 6.3 Preferred Output Ratings

The preferred output ratings, in kW, shall be:

- a) Three-phase motors: 0.75, 1.1, 1.5, 2.2, 3, 3.7, 4.5, 5.5, 7.5, 9.3, 11, 13, 15, 18.5, 22, 26, 30, 37,45, 55, 63, 67 and 75; and
- b) Single-phase motors: 0.37, 0.55, 0.75, 1.1, 1.5 and 2.2.

NOTE — For three-phase motor output ratings below and above specified the ratings may be permitted.

## 6.4 Speed

The preferred speed shall correspond to 4 or 2-pole motors [1 500 or 3 000 rev/min (synchronous)].

## 7 DIMENSIONS AND TOLERANCES

### 7.1 Dimensions of Motors

The maximum overall diameter of bore hole submersible motors covered in this standard are 98 mm, 120 mm, 146 mm, and 196 mm for borewell applications. For other applications including openwell submersible pumpset, there is no dimensional constraint.

NOTE — Motor with overall diameter of greater than 196 mm can be manufactured for 200 mm dia. and above, if required by the user.

#### 7.1.1 Dimension of Shafts of Submersible Motors for Borehole Pumps

Recommended dimensions for shafts of submersible motors for borehole pumps are given in [Fig. 5](#) to [Fig. 12](#).

### 7.2 Tolerances

**7.2.1** For motors with anti-friction bearings, the accuracies of shaft extension runout, concentricity of mounting rabbet and face runout, if not otherwise specified, shall be of normal class given in Table 6

and Table 7 of IS 2223 for all sizes of submersible motors for boreholes 100 mm to 200 mm.

**7.2.2** For motors with journal bearings, the face run out on the spigot and shaft run out shall not be more than 125 microns and eccentricity shall not be more than 100 microns. The method of measurement shall be as per [Fig.15](#) to [Fig. 17](#).

## 8 TYPE OF DUTY

The motor shall be of continuous duty (Type S1) specified in IS 15999 (Part 1)/IEC 60034-1.

## 9 LIMITS OF TEMPERATURE RISE

The temperature rise of insulated windings of stator shall meet the requirements given in [19](#).

## 10 OVERLOADS

The motors shall meet the requirements specified in [18](#).

## 11 PERFORMANCE CHARACTERISTICS

**11.1** Minimum full load speed, maximum full load current, minimum starting torque, minimum efficiency for 2 pole submersible motors of single-phase and three-phase at rated voltage of 240 V and 415 V respectively and suitable for bores of 100 mm, 125 mm, 150 mm and 200 mm, and other applications shall be in accordance with [Table 2](#) to [Table 11](#).

### NOTES

**1** For three-phase motors, the value of the full load current shall be taken as the arithmetic average of the currents measured in the three phases. The value of stator resistance shall also be taken as the arithmetic average of the resistance measured in the three phases.

**2** For motor having rated voltage other than 415 V for three-phase and 240 V for single-phase, values given in [Table 2](#) to [Table 11](#) shall be applicable except for the value of maximum full load current, which would be changed in the inverse proportion of the voltage.

**3** In case the manufacturer declares superior nominal values of performance than specified in [Table 2](#) to [Table 11](#) declared values shall be subject to verification. The observed values of the performance characteristics obtained from the test results shall confirm to the declared values of the manufacturer. Tolerance is not applicable for the declared values of the manufacturer.

**4** Performance values for other submersible motors not specified in this standard (irrespective of bore sizes, number

of poles, and number of phases) shall be as declared by the manufacturer. These values will not have any tolerance applicable to them.

**5** Speed is to be corrected for 50 Hz.

**6** Full load test to determine efficiency, power factor and slip — The tests shall be carried out at rated voltage and rated frequency.

## 11.2 Power Factor

If a statement of power factor of the motor is required, the purchaser shall specify at the time of enquiry.

## 12 EFFICIENCY

**12.1** The statement of efficiency at rated load of the motor shall be made by the manufacturer. The values for 2 pole and 4 pole motors shall not be inferior to those given in [Table 2](#) to [Table 11](#).

### NOTES

**1** For determination of efficiency of three-phase submersible motors by summation of losses method as outlined in IS 4029, the stator copper losses I<sup>2</sup>R shall be calculated using the value of resistance as at 50 °C for motors wound with PVC/poly wrap insulation and 75 °C for motors wound with enamelled copper wires.

**2** For determination of efficiency of single-phase submersible motors by method as outlined in IS 7572 shall be adapted.

**3** Brief description of various types of motor provided in [Annex B](#).

## 12.2 Tolerances

Unless otherwise specified, tolerance on locked rotor current and full load power factor shall be in accordance with IS:15999 part 1/IEC 60034-1. Where a tolerance is stated in the other direction, is considered unimportant.

## 12.3 Performance Values

Nominal values of performance is specified in [Table 2](#) is given below:

## 13 TERMINAL MARKINGS

The terminal markings or identification of lead wires shall be clearly given for proper connections to the supply system.

**Table 2 Values of Performance Characteristics for 2-Pole, 415 Volt, 50 Hz Three-Phase Water Filled Submersible Motors for Bore Size Nominal 100 mm shall Have Maximum OD of Motor 98 mm.**

(Clauses [11.1](#) and [12.1](#))

Sl No.	Rated Output kW	Minimum Full Load Speed rpm	Maximum Full Load Current A	Minimum Starting Torque (in Terms of Percentage of Full Load Torque)	Minimum Efficiency				
					Percent				
(1)	(2)	(3)	(4)	(5)	EL1	EL2	EL3	EL4	EL5
i)	0.75	2740	3.5	125	52.0	54.6	57.2	59.8	62.3
ii)	1.1	2 740	4.0	125	56.0	58.6	61.1	63.6	66.0
iii)	1.5	2 740	4.8	125	60.0	62.5	64.9	67.3	69.6
iv)	2.2	2 760	6.9	125	63.0	65.4	67.8	70.0	72.2
v)	3.0	2 760	9.0	125	63.0	65.4	67.8	70.0	72.2
vi)	3.7	2 780	10.6	125	64.0	66.4	68.7	70.9	73.0
vii)	4.5	2 780	12.6	125	67.0	69.3	71.5	73.6	75.6
viii)	5.5	2790	15.5	125	68.0	70.2	72.4	74.5	76.4

NOTES

1 The different levels of efficiencies mentioned are minimum value and no tolerance applicable.

2 For motors with output ratings greater than 5.5 kW the performance values shall be declared by the manufacturer.

**Table 3 Values of Performance Characteristics for 2-Pole, 415 Volt, 50 Hz Three-Phase Water Filled Submersible Motors for Bore Size Nominal 125 mm shall Have Maximum OD of Motor 120 mm**

(Clauses [11.1](#) and [12.1](#))

Sl No.	Rated Output kW	Minimum Full Load Speed rpm	Maximum Full Load Current A	Minimum Starting Torque (in Terms of Percentage of Full Load Torque)	Minimum Efficiency				
					Percent				
(1)	(2)	(3)	(4)	(5)	EL1	EL2	EL3	EL4	EL5
i)	1.1	2 750	3.6	125	56.5	59.1	61.6	64	66.5
ii)	1.5	2 750	4.6	125	63	65.4	67.8	70	72.2
iii)	2.2	2 770	6.7	125	64	67.3	69.6	71.8	73.9
iv)	3.0	2 770	8.8	125	65	67.9	69.9	71.8	74.1
v)	3.7	2 790	10.4	125	66	68.3	70.6	72.7	74.7
vi)	4.5	2 790	12.3	125	68.5	70.7	72.9	74.9	76.7
vii)	5.5	2 800	15.1	125	70.5	72.6	74.7	76.7	78.5
viii)	7.5	2 810	19.9	125	72.5	74.0	75.9	77.8	79.5

NOTES

1 The different levels of efficiencies mentioned are minimum value and no tolerance applicable.

2 For motors with output ratings greater than 7.5kW, the performance values shall be declared by the manufacturer.

**Table 4 Values of Performance Characteristics for 2-Pole, 415 Volt, 50 Hz Three-Phase Water Filled Submersible Motors for Bore Size Nominal 150 mm shall Have Maximum OD of Motor 146 mm.**(Clauses [11.1](#) and [12.1](#))

SI No.	Rated Output kW	Minimum Full Load Speed rpm	Maximum Full Load Current A	Minimum Starting Torque (in Terms of Percentage of Full Load Torque)	Minimum Efficiency Percent				
					EL1 (6)	EL2 (7)	EL3 (8)	EL4 (9)	EL5 (10)
(1)	(2)	(3)	(4)	(5)	(6)	(7)	(8)	(9)	(10)
i)	1.1	2 750	3.3	125	57.0	59.6	62.1	64.5	66.9
ii)	1.5	2 750	4.5	125	66.0	68.3	70.6	72.7	74.7
iii)	2.2	2 770	6.5	125	67.0	69.3	71.5	73.6	75.6
iv)	3.0	2 770	8.5	125	67.0	69.3	71.5	73.6	75.6
v)	3.7	2 790	10.0	125	68.0	70.2	72.4	74.5	76.4
vi)	4.5	2 790	12.0	125	70.0	72.2	74.2	76.2	78.1
vii)	5.5	2 810	14.5	125	73.0	75.0	76.9	78.8	80.5
viii)	7.5	2 810	19.5	125	74.0	76.0	77.8	79.6	81.3
ix)	9.3	2 830	25.0	125	75.0	76.9	78.7	80.5	82.1
x)	11.0	2 830	29.0	125	76.0	77.9	79.6	81.3	82.8
xi)	13.0	2 850	34.0	125	77.0	78.8	80.5	82.1	83.6
xii)	15.0	2 850	39.0	125	78.0	79.8	81.4	82.9	84.4

## NOTES

1 The different levels of efficiencies mentioned are minimum value and no tolerance applicable.

2 For motors with output ratings greater than 15kW, the performance values shall be declared by the manufacturer.

**Table 5 Values of Performance Characteristics for 2-Pole, 415 Volt, 50 Hz Three Phase, Oil Filled Submersible Motors for Bore Size Nominal 150 mm Shall Have Maximum OD of Motor 146 mm**(Clauses [11.1](#) and [12.1](#))

SI No.	Rated Output kW	Minimum Full Load Speed rpm	Maximum Full Load Current A	Minimum Starting Torque (in Terms of Percentage of Full Load Torque)	Minimum Efficiency Percent				
					EL1 (6)	EL2 (7)	EL3 (8)	EL4 (9)	EL5 (10)
(1)	(2)	(3)	(4)	(5)	(6)	(7)	(8)	(9)	(10)
i)	2.2	2810	5.8	125	71.0	73.1	75.1	77.1	78.9
ii)	3.0	2810	7.8	125	73.0	75.0	76.9	78.8	80.5
iii)	3.7	2830	9.1	125	74.5	76.4	78.3	80.0	81.7
iv)	4.5	2830	11.1	125	76.0	77.9	79.6	81.3	82.8
v)	5.5	2850	13.8	125	77.0	78.8	80.5	82.1	83.6
vi)	7.5	2850	18	125	78.5	80.2	81.8	83.4	84.8
vii)	9.3	2870	23.4	125	79.5	81.2	82.7	84.2	85.5
viii)	11.0	2870	27.3	125	80.5	82.1	83.6	85.0	86.3
ix)	13.0	2870	32	125	81.5	83.0	84.5	85.8	87.0
x)	15.0	2880	36.7	125	82.0	83.5	84.9	86.2	87.4

## NOTES

1 The different levels of efficiencies mentioned are minimum value and no tolerance applicable.

2 For motors with output ratings greater than 15kW, the performance values shall be declared by the manufacturer.

**Table 6 Values of Performance Characteristics for 2-Pole, 415 Volt, 50 Hz Three Phase, Water Filled Submersible Motors for Bore Size Nominal 200 mm shall have Maximum OD of Motor 196 mm**

(Clauses [11.1](#) and [12.1](#))

Sl No.	Rated Output kW	Minimum Full Load Speed rpm	Maximum Full Load Current A	Minimum Starting Torque (in Terms of Percentage of Full Load Torque)	Minimum Efficiency Percent				
					EL1	EL2	EL3	EL4	EL5
(1)	(2)	(3)	(4)	(5)	(6)	(7)	(8)	(9)	(10)
i)	3.0	2 780	8.5	125	69.0	71.2	73.3	75.3	77.2
ii)	3.7	2 790	10.0	125	70.0	72.2	74.2	76.2	78.1
iii)	4.5	2 800	12.0	125	72.0	74.1	76.0	77.9	79.7
iv)	5.5	2 810	14.5	125	75.0	76.9	78.7	80.5	82.1
v)	7.5	2 820	19.5	125	76.0	77.9	79.6	81.3	82.8
vi)	9.3	2 830	25.0	125	77.0	78.8	80.5	82.1	83.6
vii)	11.0	2 840	29.0	125	78.0	79.8	81.4	82.9	84.4
viii)	13.0	2 850	34.0	125	79.0	80.7	82.3	83.8	85.1
ix)	15.0	2 860	39.0	125	80.0	81.6	83.2	84.6	85.9
x)	18.5	2 860	48.0	125	80.0	81.6	83.2	84.6	85.9
xi)	22.0	2 870	57.0	125	80.0	81.6	83.2	84.6	85.9
xii)	26.0	2870	66	125	81.0	82.6	84.0	85.4	86.7
xiii)	30.0	2870	76	125	81.0	82.6	84.0	85.4	86.7
xiv)	37.0	2870	85	125	82.0	83.5	84.9	86.2	87.4
xv)	45.0	2870	100	125	82.0	83.5	84.9	86.2	87.4
xvi)	55.0	2870	120	125	83.0	84.4	85.8	87.0	88.2
xvii)	63.0	2870	135	125	83.0	84.4	85.8	87.0	88.2
xviii)	67.0	2870	144	125	84.0	85.4	86.6	87.8	88.9
xix)	75.0	2870	158	125	84.0	85.4	86.6	87.8	88.9

**NOTES**

**1** The different levels of efficiencies mentioned are minimum value and no tolerance applicable.

**2** For motors with output ratings greater than 75kW, the performance values shall be declared by the manufacturer.

**Table 7 Values of Performance Characteristics for 2-Pole, 240 Volt, 50 Hz Single Phase, Capacitor Start and Run (CSR), Capacitor Start and Capacitor Run (CSCR), Water Filled Submersible Motors for Bore Size Nominal 100 mm shall have Maximum OD of Motor 98 mm**

(Clauses [11.1](#) and [12.1](#))

SI No.	Rated Output kW	Minimum Full Load Speed rpm	Maximum Full Load Current A	Minimum Efficiency				
				Percent				
				EL1	EL2	EL3	EL4	EL5
(1)	(2)	(3)	(4)	(5)	(6)	(7)	(8)	(9)
i)	0.37	2 740	5.3	40.0	42.6	45.1	47.8	50.4
ii)	0.55	2 750	6.2	42.0	44.6	47.1	49.8	52.5
iii)	0.75	2 760	7.5	46.0	48.6	51.3	53.9	56.5
iv)	1.1	2 760	10.5	49.0	51.6	54.3	56.9	59.4
v)	1.5	2 770	13.8	52.0	54.6	57.2	59.8	62.5
vi)	2.2	2 770	19.8	56.0	58.6	61.1	63.6	66.0

NOTES

1 The different levels of efficiencies mentioned are minimum value and no tolerance applicable.

2 Minimum starting torque for CSR type: 30 percent of full load torque, and for CSCR types: 125 percent of full load torque.

**Table 8 Values of Performance Characteristics for 2-Pole, 240 Volt, 50 Hz Single Phase Capacitor Start and Run (CSR), Capacitor Start and Capacitor Run (CSCR), Oil Filled/or Encapsulated Oil Filled, Submersible Motors for Bore Size Nominal 100 mm shall have Maximum OD of Motor 98 mm**

(Clauses [11.1](#) and [12.1](#))

SI No.	Rated Output kW	Minimum Full Load Speed rpm	Maximum Full Load Current A	Minimum Efficiency				
				Percent				
				EL1	EL2	EL3	EL4	EL5
(1)	(2)	(3)	(4)	(5)	(6)	(7)	(8)	(9)
i)	0.37	2 780	4.1	43.0	45.6	48.2	50.9	53.5
ii)	0.55	2 780	5	45.0	47.6	50.3	52.9	55.5
iii)	0.75	2 790	6.7	50.0	52.6	55.2	57.8	60.4
iv)	1.1	2 790	9.5	53.0	55.6	58.2	60.7	63.2
v)	1.5	2 800	12.5	56.0	58.6	61.1	63.6	66.0
vi)	2.2	2 800	16	62.0	64.4	66.8	69.1	71.3

NOTES

1 The different levels of efficiencies mentioned are minimum value and no tolerance applicable.

2 Minimum starting torque: 30 percent of full load torque.

**Table 9 Values of Performance Characteristics for 2-Pole, 240 Volt, 50 Hz Single Phase Capacitor Start and Run (CSR), Capacitor Start and Capacitor Run (CSCR), Water Filled Submersible Motors for Openwell Submersible Pumpset (Clauses 14.7.1, 14.8.1, 16.3.1 and 16.5.2)**

(Clauses [11.1](#) and [12.1](#))

SI No.	Rated Output kW	Minimum Full Load Speed rpm	Maximum Full Load Current A	Minimum Efficiency				
				Percent				
				EL1	EL2	EL3	EL4	EL5
(1)	(2)	(3)	(4)	(5)	(6)	(7)	(8)	(9)
i)	0.37	2740	5.3	40.0	41.2	42.5	43.7	45.0
ii)	0.55	2 750	6.2	42.0	43.3	44.5	45.8	47.1
iii)	0.75	2 760	7.5	46.0	47.3	48.6	49.8	51.1
iv)	1.1	2 760	10.5	49.0	50.3	51.6	52.8	54.1
v)	1.5	2 770	13.8	52.0	53.3	54.6	55.8	57.1
vi)	2.2	2 770	19.8	56.0	57.3	58.5	59.7	61.0

NOTES

- 1 The different levels of efficiencies mentioned are minimum value and no tolerance applicable.  
2 Minimum starting torque: 30 percent of full load torque.

**Table 10 Values of Performance Characteristics for 2-Pole, 415 Volt, 50 Hz Three Phase, Water Filled Submersible Motors for Openwell Submersible Pumpset**

(Clauses [11.1](#) and [12.1](#))

SI No.	Rated Output kW	Minimum Full Load Speed rpm	Maximum Full Load Current A	Minimum Starting Torque (in Terms of Percentage of Full Load Torque)	Minimum Efficiency				
					Percent				
					EL1	EL2	EL3	EL4	EL5
(1)	(2)	(3)	(4)	(5)	(6)	(7)	(8)	(9)	(10)
i)	1.1	2 780	3.25	125	57.0	58.3	59.5	60.7	61.9
ii)	1.5	2 780	4.5	125	66.0	67.1	68.3	69.4	70.4
iii)	2.2	2 780	6.5	125	69.0	70.1	71.2	72.2	73.2
iv)	3.0	2 780	8.5	125	69.0	70.1	71.2	72.2	73.2
v)	3.7	2 790	10.0	125	70.0	71.1	72.1	73.1	74.1
vi)	4.5	2 800	12.0	125	72.0	73.0	74.0	75.0	75.9
vii)	5.5	2 810	14.5	125	75.0	75.9	76.9	77.8	78.6
viii)	7.5	2 820	19.5	125	76.0	76.9	77.8	78.7	79.5
ix)	9.3	2 830	25.0	125	77.0	77.9	78.8	79.6	80.4
x)	11.0	2 840	29.0	125	78.0	78.9	79.7	80.5	81.3
xi)	13.0	2 850	34.0	125	79.0	79.8	80.7	81.4	82.2
xii)	15.0	2 860	39.0	125	80.0	80.8	81.6	82.3	83.1
xiii)	18.5	2 860	48.0	125	80.0	80.8	81.6	82.3	83.1
xiv)	22.0	2 870	57.0	125	80.0	80.8	81.6	82.3	83.1

NOTES

- 1 The different levels of efficiencies mentioned are minimum value and no tolerance applicable.  
2 For motors with output ratings greater than 22 kW, the performance values shall be declared by the manufacturer.

**Table 11 Values of Performance Characteristics for 4-Pole, 415 Volt, 50 Hz Three Phase, Water Filled Submersible Motors for Openwell Submersible Pumpset***(Clauses 11.1 and 12.1)*

SI No.	Rated Output kW	Minimum Full Load Speed rpm	Maximum Full Load Current A	Minimum Starting Torque (in Terms of Percentage of Full Load Torque)	Minimum Efficiency				
					Percent				
(1)	(2)	(3)	(4)	(5)	EL1	EL2	EL3	EL4	EL5
i)	1.1	1360	3.4	125	51	52.3	53.6	54.8	56.1
ii)	1.5	1370	4.7	125	59.5	60.7	61.9	63.1	64.3
iii)	2.2	1380	6.8	125	62	63.2	64.4	65.6	66.7
iv)	3.0	1390	8.9	125	62	63.2	64.4	65.6	66.7
v)	3.7	1400	10.4	125	63	64.2	65.4	66.5	67.6
vi)	4.5	1400	12.5	125	65	66.2	67.3	68.4	69.5
vii)	5.5	1410	15.1	125	67.5	68.6	69.7	70.8	71.8
viii)	7.5	1420	20.3	125	68.5	69.6	70.7	71.7	72.8
ix)	9.3	1420	26	125	69.5	70.6	71.6	72.7	73.7
x)	11.0	1430	30.2	125	70	71.1	72.1	73.1	74.1
xi)	13.0	1430	35.4	125	71	72.0	73.1	74.1	75.0
xii)	15.0	1430	40.6	125	72	73.0	74.0	75.0	75.9
xiii)	18.5	1430	49.9	125	73	74.0	75.0	75.9	76.8
xiv)	22.0	1430	59.3	125	75	75.9	76.9	77.8	78.6

## NOTES

1 The different levels of efficiencies mentioned are minimum value and no tolerance applicable.

2 For motors with output ratings greater than 22 kW, the performance values shall be declared by the manufacturer.

**14 INFORMATION TO BE GIVEN WITH ENQUIRY AND ORDER**

The following general information may also be furnished when enquiring for and ordering the submersible motor:

- |   |  |
|---|--|
| <ul style="list-style-type: none"> <li>a) Level of water above the submersible motor;</li> <li>b) Length of the electric cable, which is required for the submersible motor;</li> <li>c) Site and operating conditions;</li> <li>d) Reference to this standard that is, IS 9283;</li> <li>e) Diameter of the bore;</li> <li>f) Type of duty;</li> <li>g) Frequency, in Hz;</li> </ul> | <ul style="list-style-type: none"> <li>h) Number of phases;</li> <li>j) Mechanical output, in kW;</li> <li>k) Rated voltage and permitted variation;</li> <li>m) Speed, in rev/min, approximate, at the rated output;</li> <li>n) If a motor is required to operate between various limits of voltage, current, frequency or speed, the corresponding value of the voltage, current, frequency or speed respectively;</li> <li>p) System of earthing, if any, to be adopted;</li> <li>q) Particulars of tests required and where they are to be carried out; and</li> <li>r) Method of starting to be employed.</li> </ul> |
|---|--|



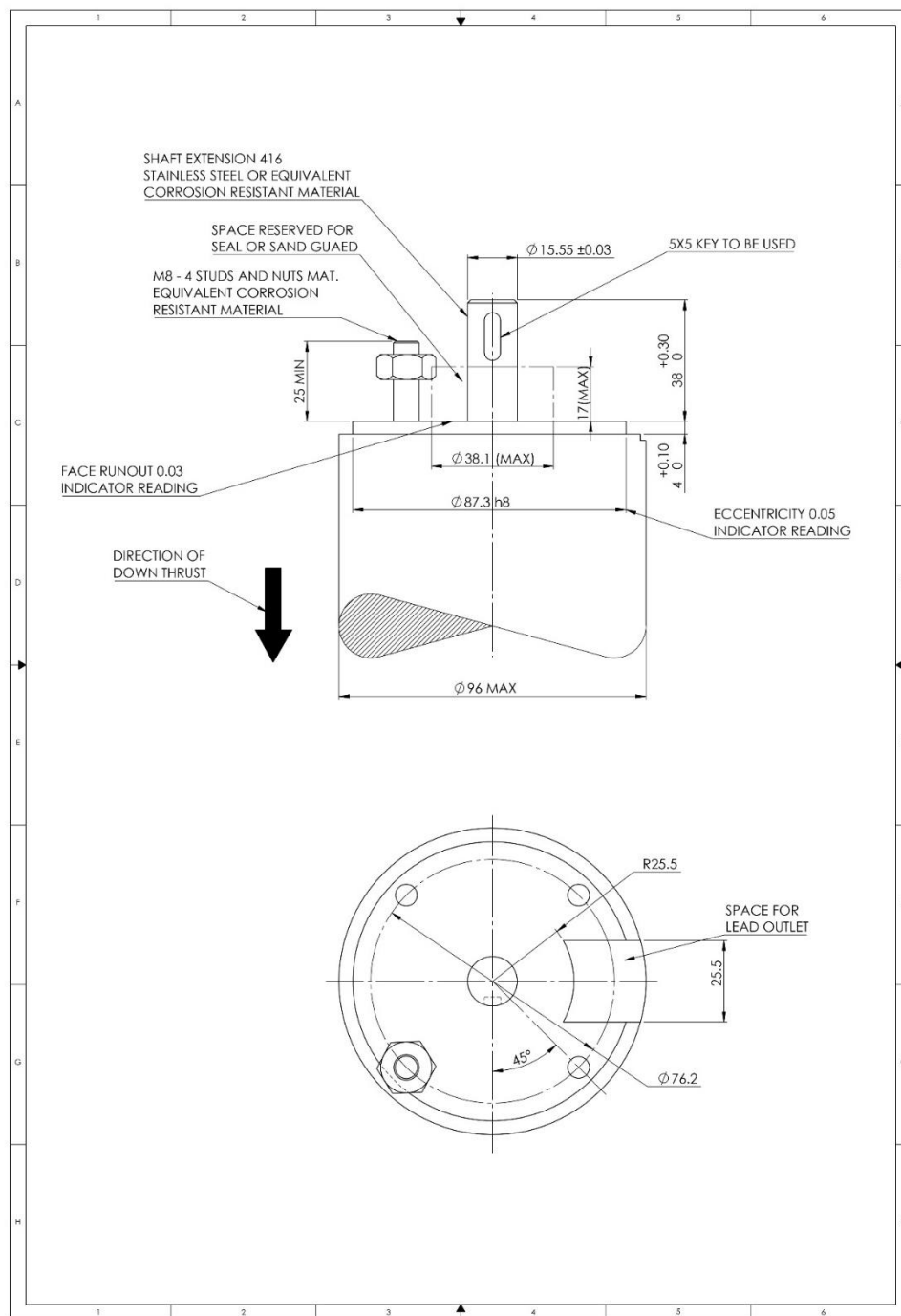

FIG. 5 RECOMMENDED KEY TYPE END CONNECTION OF SUBMERSIBLE MOTOR FOR BORE HOLE PUMPS (100 mm BORE)

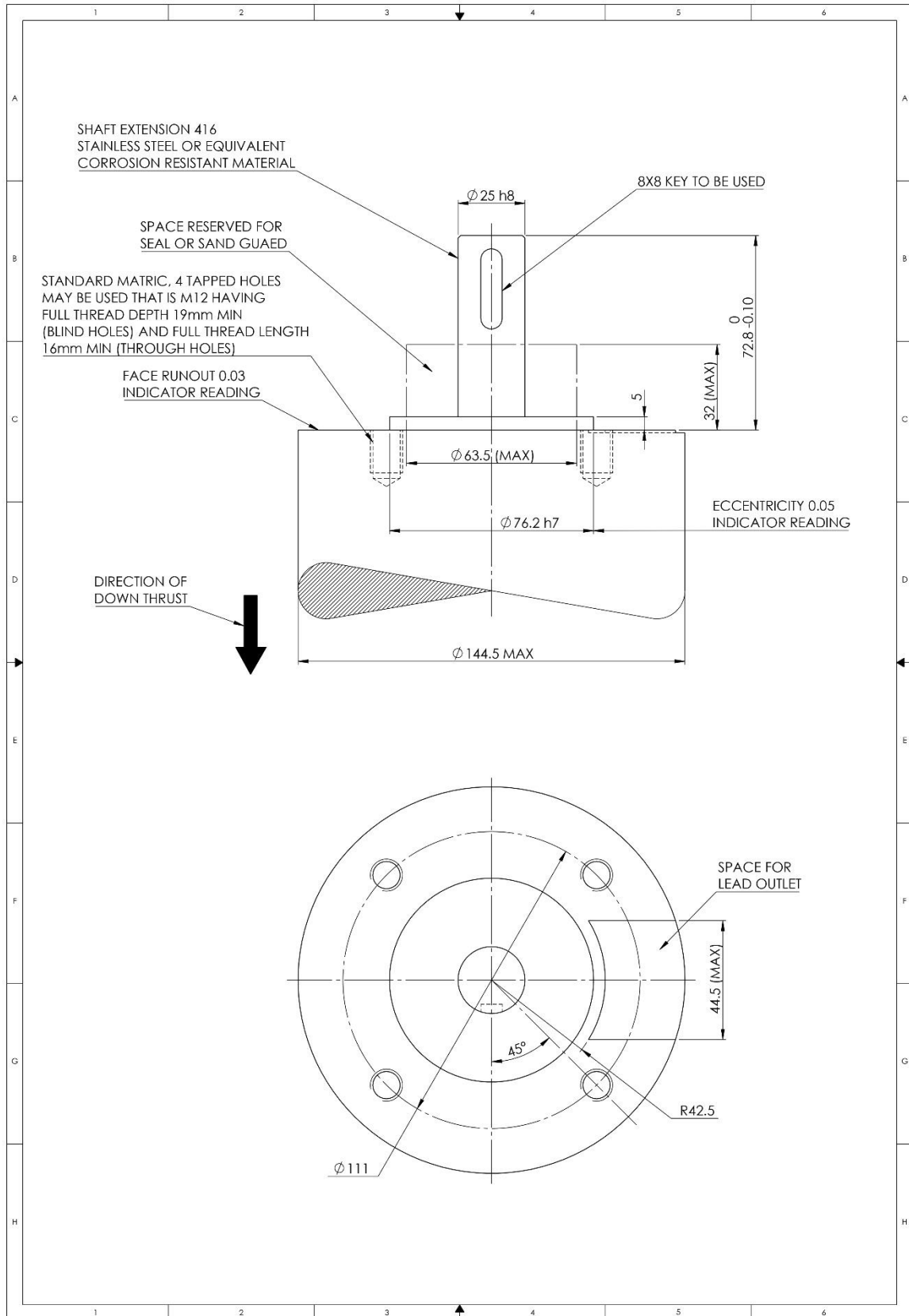

FIG. 6 RECOMMENDED KEY TYPE END CONNECTION OF SUBMERSIBLE MOTOR FOR BORE HOLE PUMPS  
(150 mm BORE)

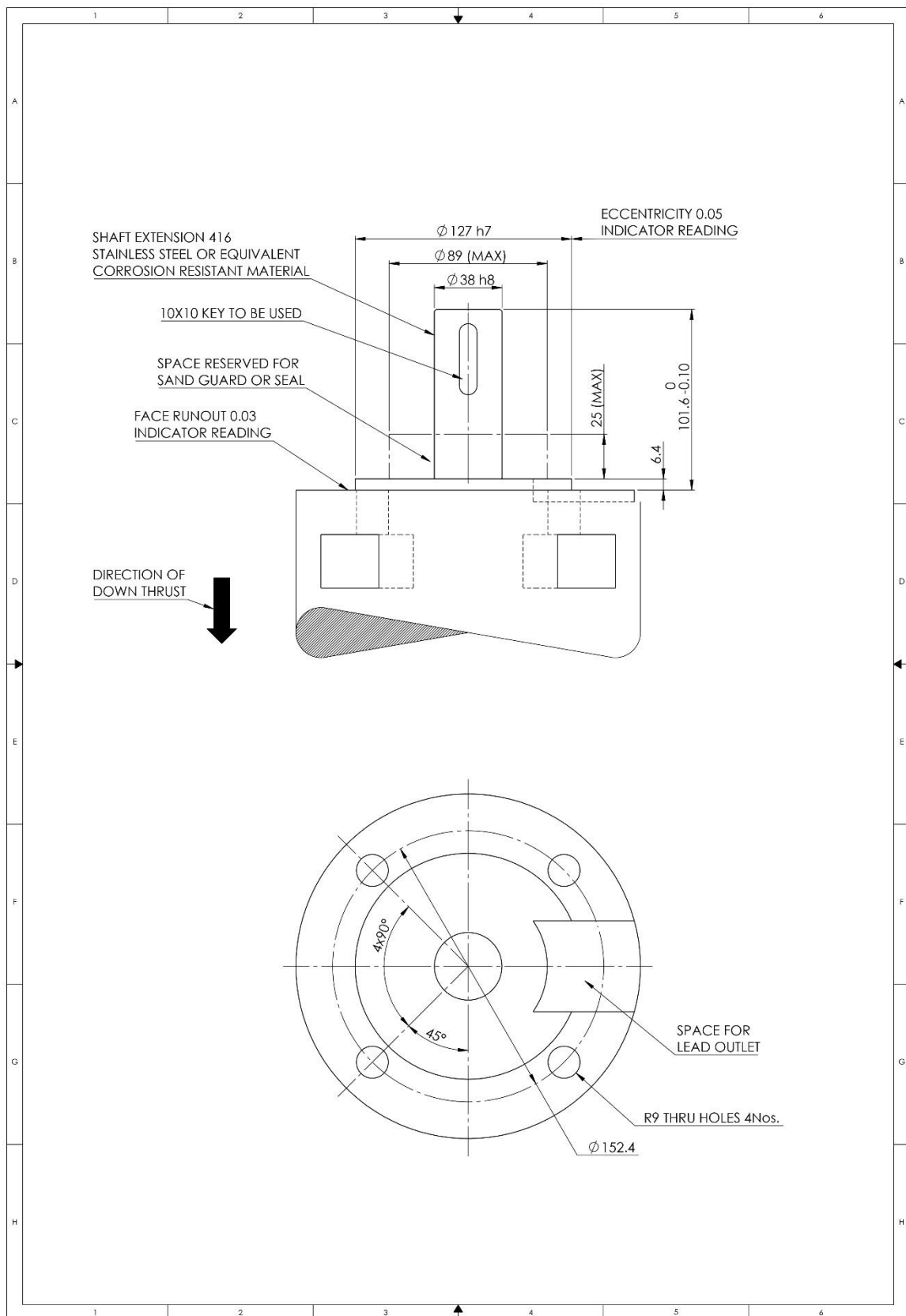

FIG. 7 RECOMMENDED KEY TYPE END CONNECTION OF SUBMERSIBLE MOTOR FOR BORE HOLE PUMPS (200 mm BORE)

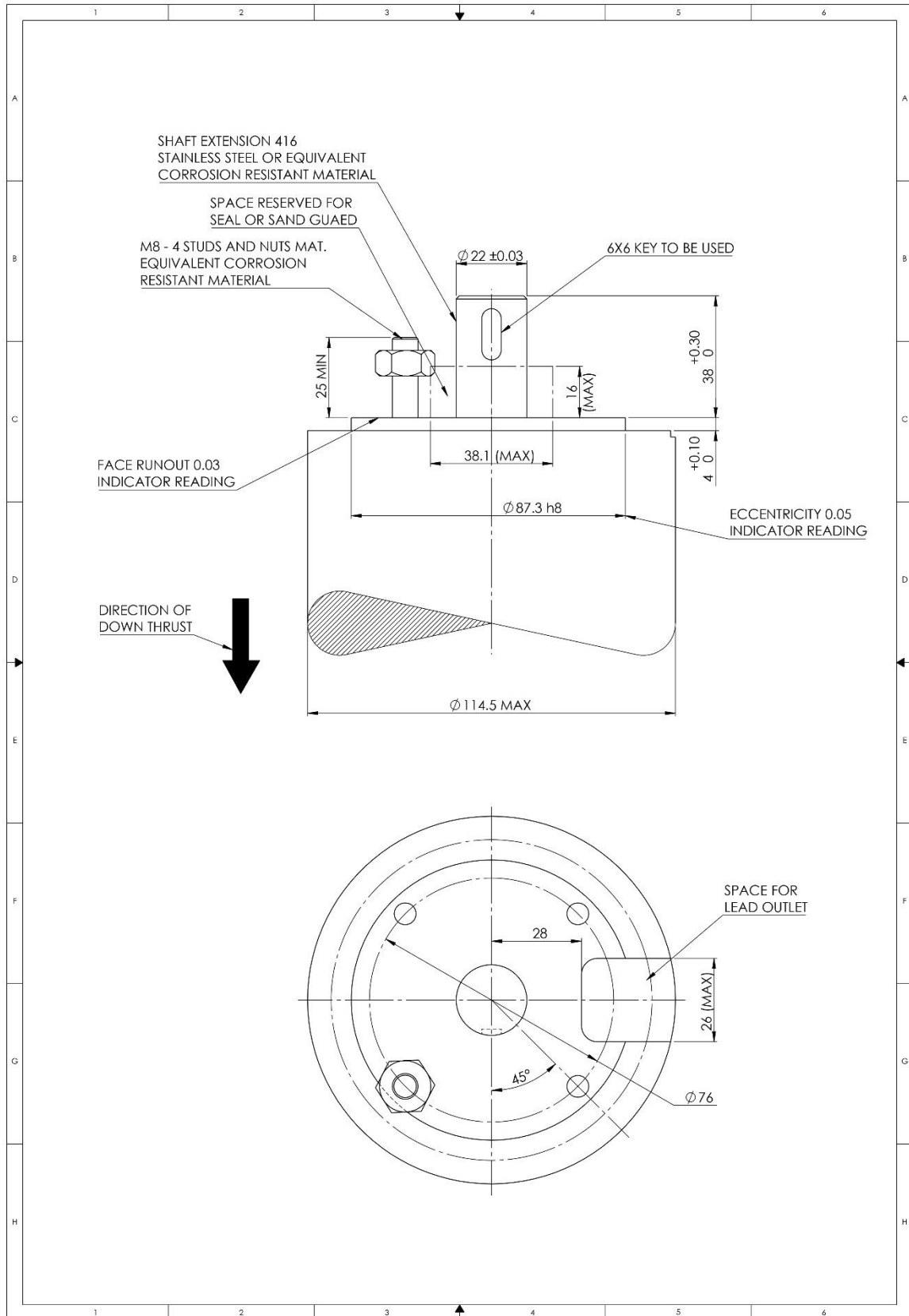

FIG. 8 RECOMMENDED KEY TYPE END CONNECTION OF SUBMERSIBLE MOTOR FOR BORE HOLE PUMPS  
(125 mm BORE)

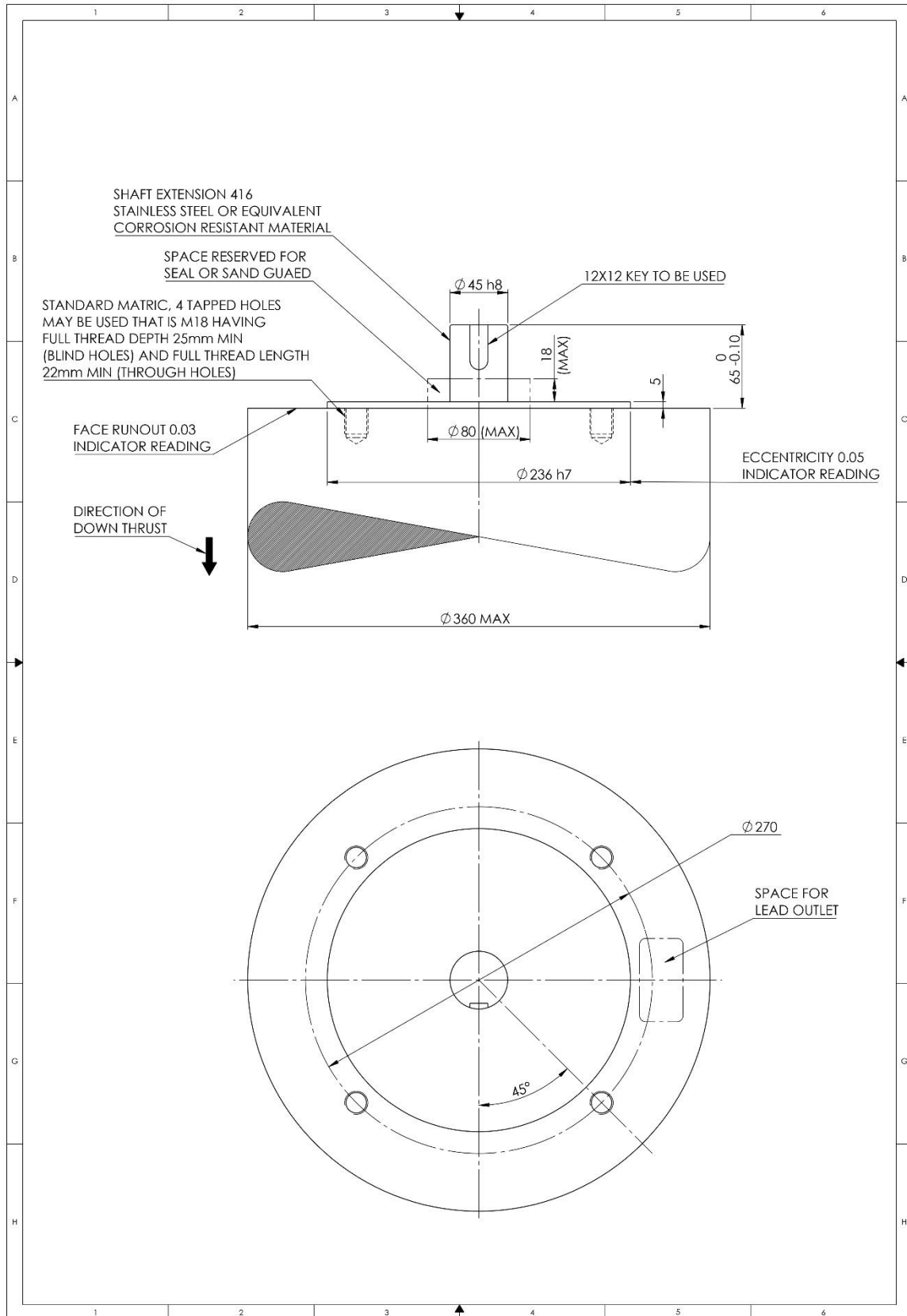
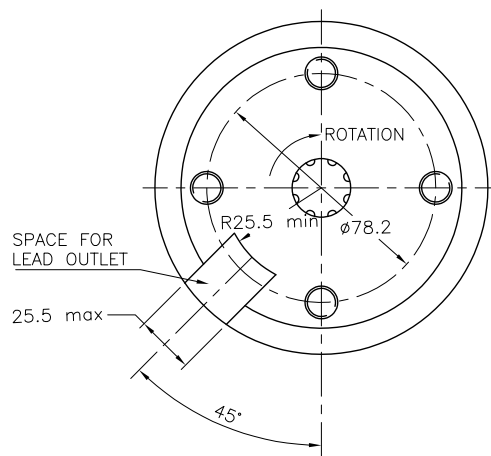
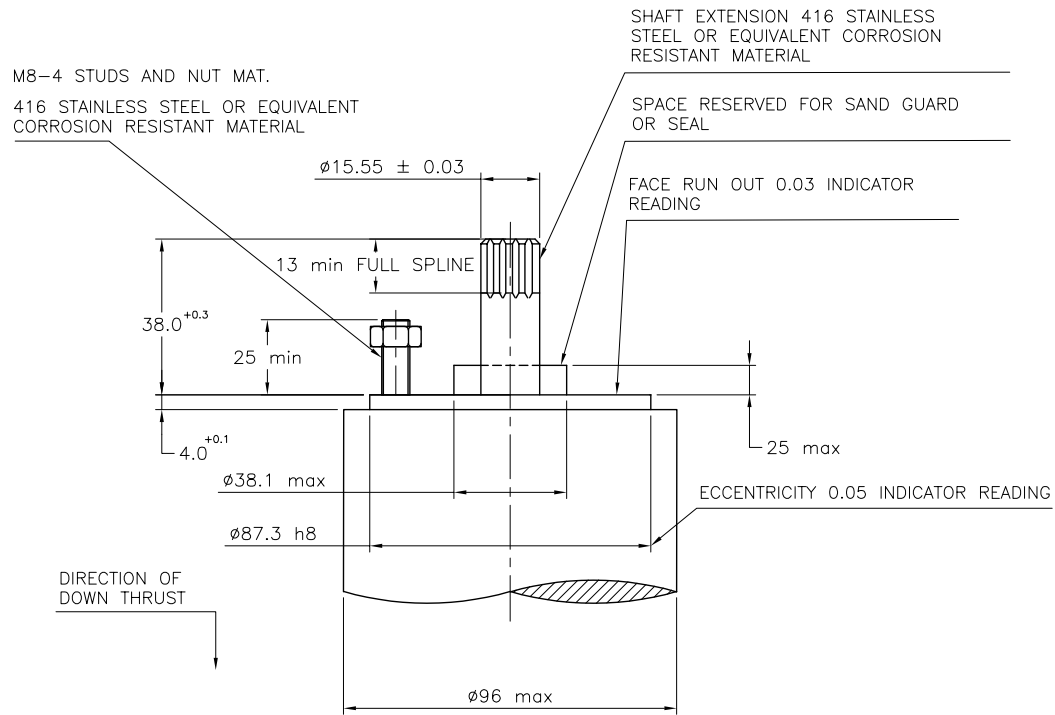

FIG. 9 RECOMMENDED KEY TYPE END CONNECTION OF SUBMERSIBLE MOTOR FOR OPENWELL  
SUBMERSIBLE PUMPS



ALL DIMENSION IN MILLIMETERS

NOTES

- 1 Normal operating position of motors is vertical with shaft up.
- 2 For spline data (see [Fig. 13](#)).
- 3 Substitute measure dia (spline) as 15.6 - 0.00/-0.05 for 15.6 - 0.00/-0.03.

FIG. 10 RECOMMENDED END CONNECTION (SPLINE) OF SUBMERSIBLE MOTOR FOR BORE HOLE PUMPS (100 mm BORE)

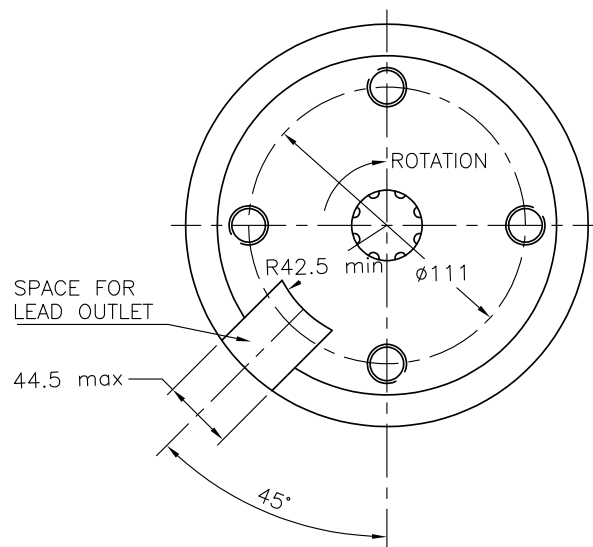
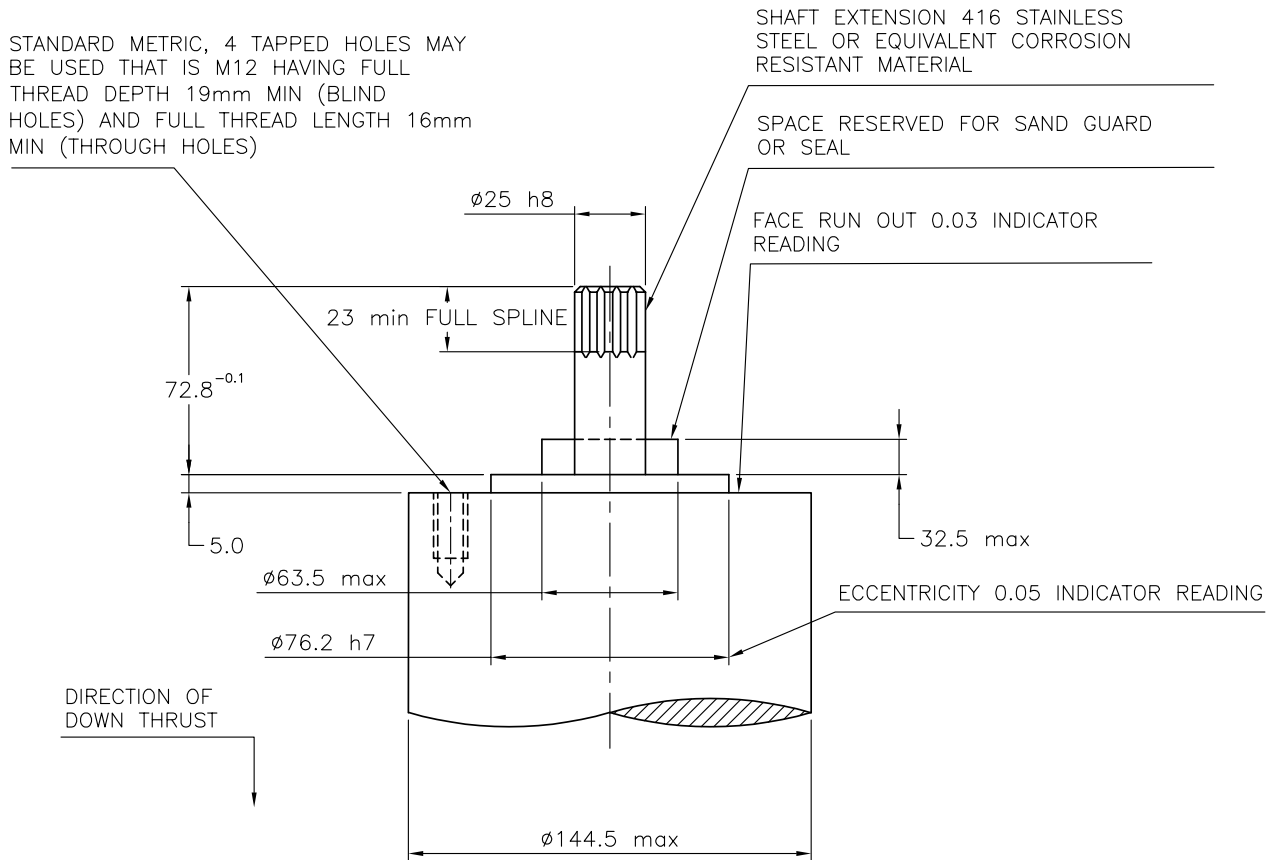

ALL DIMENSION IN MILLIMETERS

NOTES

- 1 Normal operating position of motors is vertical with shaft up.
- 2 For spline data (see Fig. 13).
- 3 Substitute measure dia (spline) as  $25_{-0.00/-0.05}$  for  $25_{-0.00/-0.03}$

FIG. 11 RECOMMENDED END CONNECTION(SPLINE) OF SUBMERSIBLE MOTOR FOR BORE HOLE PUMPS (150 mm BORE)

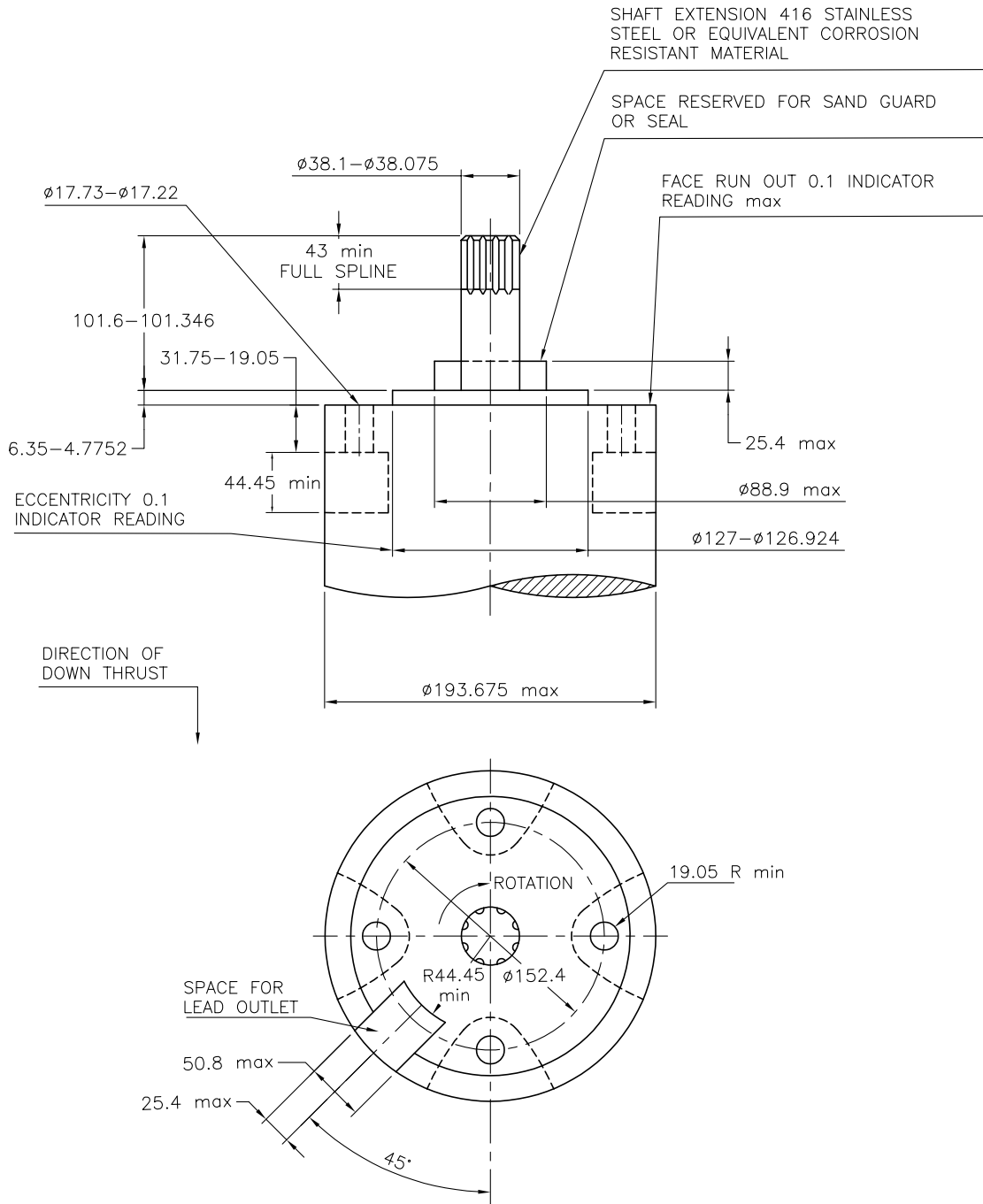

ALL DIMENSION IN MILLIMETER

NOTES

- 1 Normal operating position of motors is vertical with shaft up.
- 2 For spline data (see Fig. 14).
- 3 Reference : NEMA MG 1-2016 Section II Part 18 – Page 59.

FIG. 12 RECOMMENDED END CONNECTION(SPLINE) OF SUBMERSIBLE MOTOR FOR BORE HOLE PUMPS (200 mm BORE)



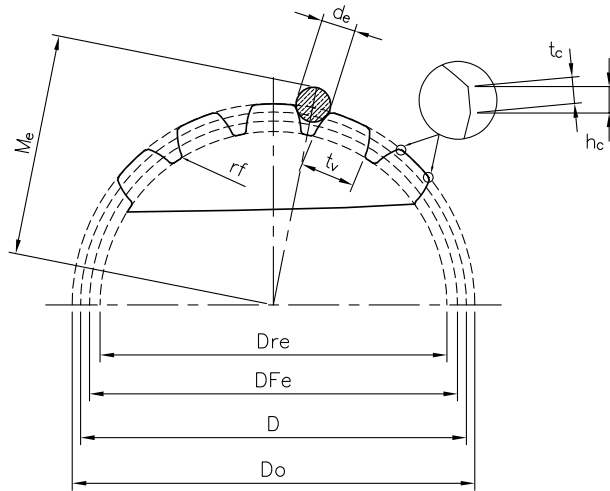

External Spline Data  
All Dimensions in millimeter

Description	Motor Suitable for Bore	
	100mm	150mm
No. of teeth, N	14	15
Diametrical pitch, P	24/48	16/32
Pressure angle	30°	30°
Base Diameter, Db	12.83	20.62
Pitch Diameter, D	14.80 ± 0.1	23.81 ± 0.1
Major Diameter, Do	15.60 <sup>-0.05</sup>	25.00 <sup>-0.05</sup>
Form Diameter, DFe	13.70 ± 0.1	22.10 ± 0.1
Minor Diameter, Dre	13.3 ± 0.1	20.53 ± 0.1
Effective Tooth Thickness, tv	1.62 ± 0.03	2.46 ± 0.03
Minimum measurement over pins, Me	17.83 ± 0.02	28.25 ± 0.02
Pin Diameter, de	2.03	3.05
Chamfer height, he	0.15	0.25
Chamfer height, le	0.2	0.3
Spline length, L Min (Effective)	13	23
Fillet radius, rf	0.1	0.15
Maximum run-out	0.025	0.025
Maximum total indexing	0.033	0.038
Maximum involute flank form error	0.012	0.02
Maximum flank deflection distortion	0.008	0.013
Type of Spline	Involute sided	Involute sided
Tolerance class	5	5

NOTES

- 1 Type of spline : Involute.
- 2 Type of fit : Fillet root side fit.
- 3 Tolerance class : 5.
- 4 All dimension in millimeter except diametrical pitch.

FIG. 13 RECOMMENDED SPLINE FOR SHAFT EXTENSION FOR SUBMERSIBLE MOTOR

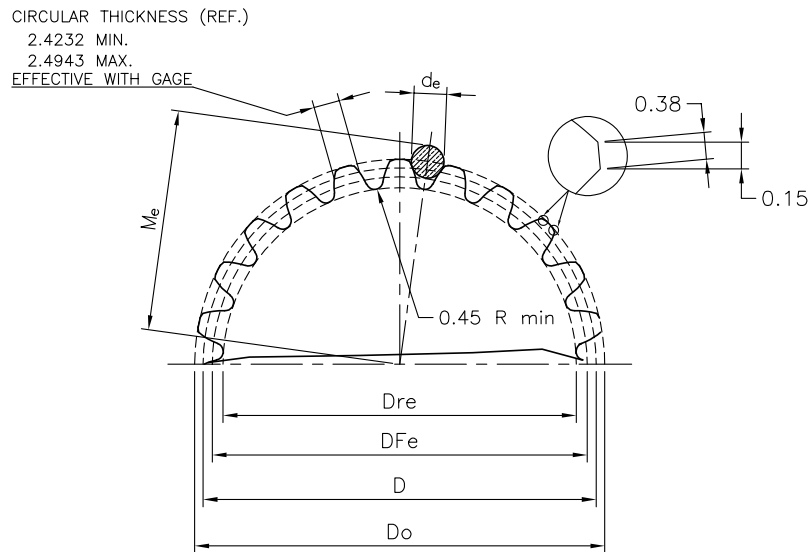

External Spline Data  
All Dimensions in millimeter

Description	
Motor Suitable for Bore	200mm
No. of teeth, N	23
Diametrical pitch, P	16/32
Pressure angle	30°
Base Diameter, Db	31.62
Pitch Diameter, D	36.50 ± 0.1
Major Diameter, Do	38.10 <sup>-0.00</sup> <sub>-0.10</sub>
Form Diameter, DFe	34.7 ± 0.1
Minor Diameter, Dre	32.72 ± 0.1
Minimum measurement over pins, Me	41.05 ± 0.02
Pin Diameter, de	3.05
Spline length, L Min (Effective)	43
Maximum run-out	0.025
Maximum total indexing	0.038
Maximum involute flank form error	0.012
Maximum flank deflection distortion	0.008
Type of Spline	Involute sided
Tolerance class	5

NOTES

- 1 Type of spline : Involute.
- 2 Type of fit : Fillet root side fit.
- 3 Tolerance class : 5.
- 4 All dimension in millimeter except diametrical pitch.
- 5 Reference : ANSI B92.1.

FIG. 14 RECOMMENDED SPLINE FOR SHAFT EXTENSION FOR SUBMERSIBLE MOTOR OF 200 mm BORE SIZE

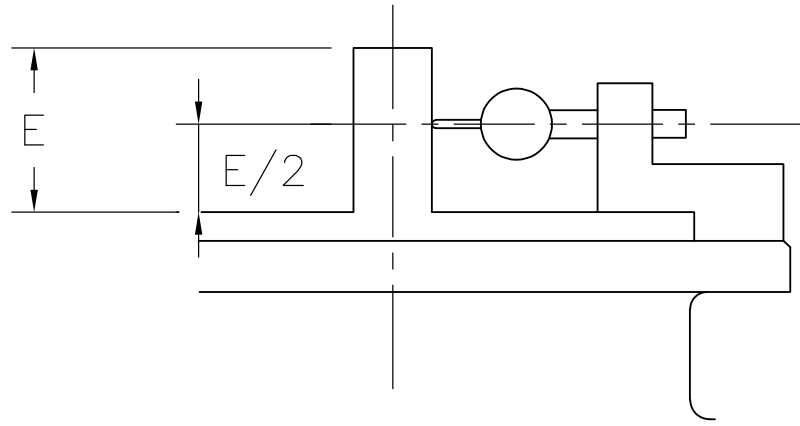

FIG. 15 MEASUREMENT OF SHAFT EXTENSION RUN-OUT

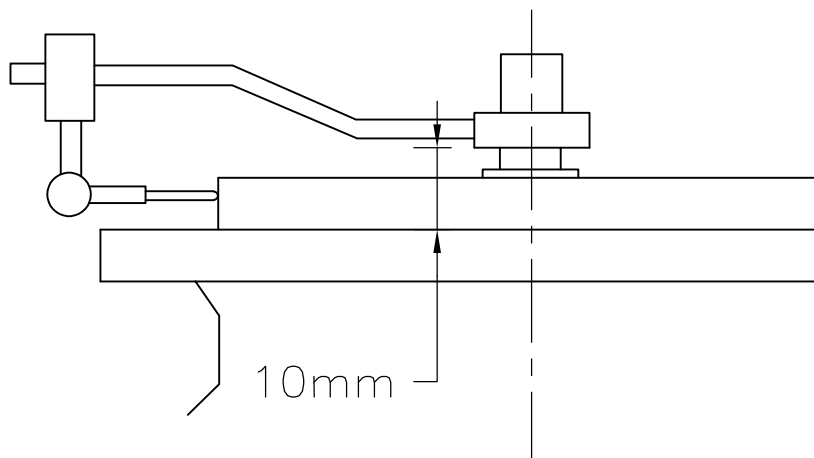

FIG. 16. MEASUREMENT OF CONCENTRICITY OF MOUNTING SPIGOT AND SHAFT

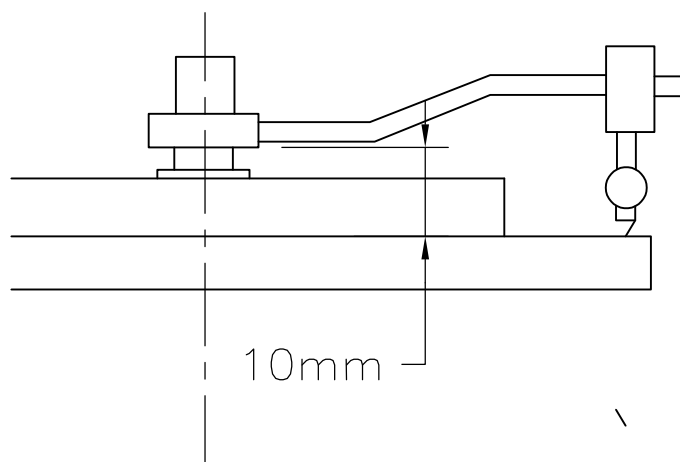

FIG. 17 MEASUREMENT OF FACE RUNOUT

## 15 RATING PLATE

15.1 The motor shall have the rating plate giving the following information:

- a) Reference to this Indian Standards, that is, IS 9283;
- b) Induction motor;
- c) Name of the manufacturer;
- d) Manufacturer's serial number;
- e) Type of duty;
- f) Frequency, in Hz;
- g) Number of phases;
- h) Rated output, in kW;
- j) Rated voltage and winding connections;
- k) Current, approximate, at rated output, in A;
- m) Speed in at rated output, in rev/min;
- n) Nominal efficiency, in percent;
- p) Category of motor and bore size, in mm;
- q) The country of origin, month and year of manufacturing; and
- r) Power factor at full load.

15.2 In addition, the manufacturer's serial number shall be punched at a convenient place for easy identification. The rating plate can be metallic or non-metallic. This rating plate can be riveted/sticked, or laser etched.

### 15.3 BIS Certification Marking

The product(s) conforming to the requirements of this standard may be certified as per the conformity assessment schemes under the provisions of the *Bureau of Indian Standards Act, 2016* and the Rules and Regulations framed thereunder, and the products may be marked with the Standard Mark.

## 16 CLASSIFICATIONS OF TESTS

### 16.1 Type Tests

The following shall constitute the type tests:

- a) Insulation resistance test (both before and after the high voltage test);
- b) High voltage test;
- c) Measurement of stator resistance;
- d) No load running of motor and reading of voltage, current, power input, frequency and speed;
- e) Reduced voltage running up test at no load to check the ability of the motor to run up to full speed on no load with 60 percent of the rated voltage applied to the motor for three-phase motors and 75 percent of the rated voltage applied to the motor for single-phase motors;

- f) Locked rotor readings of voltage, current, power input and torque of motors;

NOTE — This test may be made at a reduced voltage, when a current at least equivalent to full load current is being taken by the motor.

- g) Full load reading of voltage, current, power input, speed and frequency;

NOTE — Pump may be used as a loading device.

- h) Performance characteristics;
- j) Temperature rise test at rated voltage;
- k) Temperature rise test at reduced voltage;
- m) Momentary over-load test (as per agreement between the manufacturer and the purchaser); and
- n) Leakage current test at rated voltage at no load.

NOTE — A template for recommended proforma for preparing a type test certificate is given in [Annex C](#).

### 16.2 Routine Test

The following shall constitute the routine test:

- a) Insulation resistance test (before high voltage test only);
- b) High voltage test;
- c) No load running of motor and reading of current, voltage, power, frequency and speed;
- d) Locked rotor reading of voltage, current and power input; and

NOTE — This test may be made at reduced voltage, when a current at least equivalent to full load current is being taken by the motor.

- e) Reduced voltage running up test at no load to check the ability of the motor to run up to full speed on no load with 60 percent of the rated voltage applied to the motor for three-phase motors and 75 percent of the rated voltage applied to the motor for single-phase motors.

16.3 Tests specified shall normally be made at the manufacturer's premises.

NOTE — For the purpose of this standard, the tests to determine performance characteristics shall be made in accordance with methods specified in IS 4029 and IS 7572.

## 17 SPEED

The speed measurement may be conveniently taken by means of a slip coil or any other suitable method.

## 18 OVERLOAD TEST

### 18.1 Momentary Excess Torque

The motor shall, whatever their type of construction, be capable of withstanding for 10 s without stalling or abrupt change in speed (under gradual increase of torque) an excess torque of 60 percent of the rated

torque the voltage and frequency being maintained at their rated value.

### 18.2 Sustained Overloads

Motors rated in accordance with this standard are not capable of carrying sustained overload.

## 19 TEMPERATURE RISE TEST

**19.1** The temperature rise test of the motor at rated voltage and supply frequency shall be carried out with the motor coupled to a suitable pump for the full load current and the set run continuously for 1 h till study state temperature is achieved. The set is stopped, and the temperature rise of the stator winding computed by the resistance method shall not exceed 35 °C at rated voltage and 45 °C at 85 percent of the rated voltage when the set is run for 1 h soon after the test at rated voltage. During the test, the temperature of the cooling water surrounding the motor may not exceed 45 °C.

NOTE — Temperature rise test at 85 percent of rated voltage is not applicable for category 'A' motor.

### 19.2 Determination of Temperature Rise of Winding by Resistance Method

The temperature rise ( $t_2 - t_1$ ) may be obtained from the ratio of the resistance by the formula:

$$\frac{t_2 + 235}{t_1 + 235} = \frac{R_2}{R_1}$$

where

- $t_2$  = temperature, in °C, of the winding at the end of the test;
- $R_2$  = resistance of the winding at the end of the test measured within 30 s after shut down;
- $t_1$  = temperature, in °C, of the winding (cold) at the moment of the initial resistance measurement; and
- $R_1$  = initial resistance of the winding (cold).

For practical purpose the following alternative formula may be found convenient:

$$t_2 - t_1 = \frac{R_2 + R_1}{R_1} = (235 + t_1) + (t_1 - t_a)$$

where

- $t_a$  = temperature, in °C, of cooling medium at the end of the test.

## 20 HIGH VOLTAGE TEST

**20.1** The high voltage test shall be applied between the windings and the frame only to a new and complete motor with all of its parts in place filled with water.

The test shall be carried out at the conclusion of the temperature rise test of the motor where such a test is carried out.

**20.2** The test voltage shall be of the supply frequency and shall be as near as possible to sine wave form. The test shall be commenced at a voltage of not more than one half of the full test voltage. The voltage shall then be increased to the full value steadily or in the steps of not more than 5 percent of the full value, the time allowed for the increase of the voltage from half to full value being not less than 10 s. The full test voltage of 1 500 V shall be maintained for 30 s.

**20.3** During the routine testing of motors of rated output up to and including 5.5 kW, the 30 s test may be replaced by a test of approximately 5 s at the test voltage given in [20.2](#), following the same procedure.

**20.4** Since the test is already made on the windings for acceptance shall, as far as possible, not be repeated. If however, a second test is made at the laboratory or at the special request of the purchaser, the test voltage shall be 80 percent of the voltage (1 200 V) given in [20.2](#).

NOTE — The HV tester shall have adequate capacity to carry the leakage current of the motor.

## 21 INSULATION RESISTANCE TEST

The insulation resistance when the high voltage test is applied shall be not less than 5 MΩ. The insulation resistance shall be measured with a d.c. voltage of 500 V applied for a sufficient time for the reading of the indicator to become practically steady, such voltage being taken from an independent source or generated in the measuring instrument.

## 22 LEAKAGE CURRENT TEST

The maximum leakage current value shall not be more than 50 mA at rated voltage at no load. The motor shall be placed on either a rubber mat or a wooden base or any other insulated base. A voltage equal to the rated voltage shall be applied to any supply line and accessible outside metal parts of the motor. The resistance of the test circuit shall be 2 000 Ω ± 50 Ω.

NOTE — For safety purposes it shall be ensured during installation that the earthing is capable of taking care of leakage current.

## LIST OF REFERRED STANDARDS

IS No.	Title	IS No.	Title
IS 210 : 2009	Grey iron castings — Specification ( <i>fifth revision</i> )	IS 7572 : 1974	Guide for testing single-phase AC and universal motors
IS 318 : 1981	Specification for leaded tin bronze ingots and castings ( <i>second revision</i> )	IS 8034 : 2018	Submersible pumpsets — Specification ( <i>third revision</i> )
IS 613 : 2000	Copper rods and bars for electrical purposes — Specification ( <i>third revision</i> )	IS 8783 (Part 1) : 1995	Winding wires for submersible motors — Specification: Part 1 Conductor data ( <i>first revision</i> )
IS 648 : 2022	Cold rolled non-oriented electrical steel sheet and strip — Fully processed type — Specification ( <i>sixth revision</i> )	IS 10804 (Part 2) : 2018	Recommended pumping systems for agricultural purposes: Part 2 Submersible pump sets ( <i>third revision</i> )
IS 694 : 2010	Polyvinyl chloride insulated unsheathed and sheathed cables/cords with rigid and flexible conductor for rated voltages up to and including 450/750V ( <i>fourth revision</i> )	IS 12360 : 1988	Voltage bands for electrical installations including preferred voltages and frequency
IS 1570 (Part 5) : 1985	Schedules for wrought steels: Part 5 Stainless and heat resisting steels ( <i>second revision</i> )	IS 12615 : 2018	Line operated three phase a.c. motors (IE CODE) 'Efficiency classes and performance specification' ( <i>third revision</i> )
IS 1873 : 2019	Antichill thinner for cellulose nitrate based paints, dopes and lacquers for aircrafts — Specification ( <i>first revision</i> )	IS 13730 (Part 34) : 2000/IEC 60317-34 : 1997	Specifications for particular types of 2000 winding wires: Part 34 Polyester enamelled round copper wire Class 130 ( <i>first revision</i> )
IS 1885 (Part 35) : 2021/IEC 60050-411 : 1996	Electrotechnical vocabulary: Part 35 Rotating machines ( <i>second revision</i> )	IS 14220 : 2018	Openwell submersible pumpsets — Specification ( <i>first revision</i> )
IS 2223 : 1983	Dimensions of flange mounted ac induction motors ( <i>second revision</i> )	IS 14536 : 2018	Selection, installation, operation and maintenance of submersible pumpset — Code of practice ( <i>first revision</i> )
IS 3961 (Part 5) : 1968	Recommended current ratings for cables: Part V PVC insulated light duty cables	IS 14582 : 2021	Single phase small a.c. electric motors for centrifugal pumps for agricultural applications — Specification ( <i>first revision</i> )
IS 3073 : 1967	Assessment of surface roughness	IS 15999 (Part 1) : 2021/IEC 60034-1 : 2017	Rotating electrical machines: Part 1 Rating and performance ( <i>second revision</i> )
IS 4026 : 2023	Aluminium ingots, billets and wire bars (EC GRADE) ( <i>fifth revision</i> )	IS/ISO 21940-11 : 2016	Mechanical vibration — Rotor balancing: Part 11 Procedures and tolerances for rotors with rigid behaviour
IS 4029 : 2010	Guide for testing three phase induction motors ( <i>first revision</i> )		
IS 7538 : 1996	Three-phase squirrel cage induction motors for centrifugal pumps for agricultural applications — Specification ( <i>first revision</i> )		

To access Indian Standards click on the link below:

[https://www.services.bis.gov.in/php/BIS\\_2.0/bisconnect/knownyourstandards/Indian\\_standards/isdetails/](https://www.services.bis.gov.in/php/BIS_2.0/bisconnect/knownyourstandards/Indian_standards/isdetails/)

## ANNEX B

*(Clause [12.1](#))*

## TYPES OF MOTORS

**B-1 TYPES OF MOTORS****B-1.1 Capacitor Start Capacitor Run (Two-Value Capacitor Motor)**

These motors have higher starting torques and lower starting currents than split-phase motors and are suitable for frequent starting. They have a lower noise level, higher efficiency and power factor than split-phase motors and capacitor start and induction run motors (*see [B-1.3](#)*).

**B-1.2 Capacitor Start and Run (Permanent Split Capacitor Motor)**

These motors have lesser starting torque and starting

current than capacitor start capacitor run motors and are used where lower starting torques are acceptable. In the running condition, their characteristics are similar to capacitor start capacitor run motors.

**B-1.3 Capacitor Start Induction Run (Capacitor Start Motor)**

These motors have higher starting torques and lower starting currents than split-phase motors.

NOTE — This is the least preferred type since the load current is higher and efficiency and power factor are lower than the other two types.

**FORM FOR TEST REPORT OF MOTORS FOR SUBMERSIBLE PUMPSETS**

Name and address of the manufacturer \_\_\_\_\_  
 Purchaser \_\_\_\_\_ Certificate No. \_\_\_\_\_  
 Purchase Order No. \_\_\_\_\_ Order acceptance No. \_\_\_\_\_

**Name Plate Data**

Motor SI No. \_\_\_\_\_ Voltage \_\_\_\_\_ V  
 Output \_\_\_\_\_ kW Frequency \_\_\_\_\_ Hz  
 Speed \_\_\_\_\_ rpm Current \_\_\_\_\_ A  
 Data Type \_\_\_\_\_ Bore Well Size \_\_\_\_\_ mm

**Test Characteristics**

Loading Condition	Volts V	Amps A	Watts kW	Load	Slip Percentage	Power Factor	Efficiency
No Load							
Full Load							

**Temperature Rise Test**

Condition of Test			Watts Input kW	Calculated Output kW	Temperature Rise °C
Hours Run H	Line Voltage V	Line Current A			

At rated Volts  
 At 85 percent  
 of the rated  
 Volts

**Breakaway Torque and Starting Current**

Breakaway torque (Locked rotor) with V \_\_\_\_\_  
 Volts applied \_\_\_\_\_ kg.m

Breakaway starting current and power input (Locked rotor) with Volts applied }  
 V \_\_\_\_\_  
 W \_\_\_\_\_  
 A \_\_\_\_\_ kg.m

Insulation resistance test \_\_\_\_\_ Megaohm  
 High voltage test \_\_\_\_\_ Volt for 30 s  
 Resistance of winding \_\_\_\_\_ Ohm  
 Momentary overload \_\_\_\_\_ 15 s

Test conducted on motor No. \_\_\_\_\_ Approved By \_\_\_\_\_  
 Tested by: \_\_\_\_\_ On: \_\_\_\_\_ Date: \_\_\_\_\_



## ANNEX D

(Clause 5.4.3)

## CABLE SELECTION

**D-1** Cable size to be selected considering pumpset current, voltage drop (typically 3 percent of rated voltage) and distance between motor terminal and supply panel.

IS : 3961 (Part V) and IS : 8130 to be referred for cable current carrying capacity and cable resistance respectively, in cable selection process.

SUBMERSIBLE THREE PHASE – 415 V												
RATING		CABLE SIZE (in mm <sup>2</sup> )										
kW	HP	1.5	2.5	4	6	10	16	25	35	50	70	95
0.75	1	420	680	1 100								
1.1	1.5	310	510	820	1 240							
1.5	2	260	420	680	1 040							
2.2	3	180	290	470	720	1 220						
3	4	140	230	360	550	930						
3.7	5	120	190	310	470	790	1 250					
4.5	6	100	160	260	400	670	1 050					
5.5	7.5	80	130	210	320	540	850					
7.5	10	70	100	170	250	430	680	1 080				
9.3	12.5		80	130	200	330	530	830	1 150			
11	15		70	120	170	290	460	720	1 010			
13	17.5			100	150	250	390	610	850	1 150		
15	20			90	130	220	340	530	740	1 000		
18.5	25				100	170	280	440	600	820	1 200	
22	30				80	150	230	370	500	700	1 000	

MAXIMUM LENGTH IN METRES

SUBMERSIBLE SINGLE PHASE – 240 V												
RATING		CABLE SIZE (in mm <sup>2</sup> )										
kW	HP	1.5	2.5	4	6	10	16	25	35	50	70	95
0.37	0.5	120	210	330	500	820	1290					
0.55	0.75	80	140	230	350	580	900	1 360				
0.75	1	60	110	180	270	440	690	1 050				
1.1	1.5	40	70	120	190	310	490	750	1 020			
1.5	2		60	100	150	250	400	620	850	1 180		
2.2	3		40	60	100	170	270	410	560	770	1 030	1 320

MAXIMUM LENGTH IN METRES

## ANNEX E

*(Foreword)*

## COMMITTEE COMPOSITION

Rotating Machinery Sectional Committee, ETD 15

<i>Organization</i>	<i>Representative(s)</i>
Bharat Heavy Electricals Limited, Bhopal	SHRI MUKESH KUMAR MARAVI ( <b>Chairperson</b> )
Asea Brown Boveri Limited, Faridabad	SHRI LOKESH B. M. SHRI SUMIT TYAGI ( <i>Alternate</i> )
Bharat Bijlee Limited, Mumbai	SHRI SALIL KUMAR SHRI BHAGYASHREE SANJAY PAWAR ( <i>Alternate</i> )
Bharat Heavy Electrical Limited, New Delhi	SHRI KRUSHNA CHANDRA PANDA SHRI P. DALI NAIDU ( <i>Alternate</i> )
Central Electricity Authority, New Delhi	SHRI JITESH SHRIVAS SHRI RISHABH GAUR ( <i>Alternate</i> )
Central Power Research Institute, Bengaluru	SHRI S. PRASHOB
Electrical Research and Development Association, Vadodara	SHRI RAVI SINGH SHRI JITENDRA TAHILWANI ( <i>Alternate</i> )
Engineers India Limited, New Delhi	SHRI RAMAN SOOD SHRI RAVISH K. RAMAN ( <i>Alternate</i> )
Havells India Limited, Noida	SHRI VINAYAK ATRE SHRI ANIL SUKUMAR AKOLE ( <i>Alternate</i> )
Hindustan Electric Motors, Mumbai	SHRI SANJAY P. JADIA SHRI DILIP BHAVE ( <i>Alternate</i> )
Indian Electrical and Electronics Manufacturers Association, New Delhi	SHRI SEETHARAMAN K. SHRI PRAVEEN KUMAR ( <i>Alternate</i> )
Indian Pump Manufacturers Association, Mumbai	SHRI K. V. KARTHIK SHRI UTKARSH A. CHHAYA ( <i>Alternate I</i> ) SHRI ANOOP AGARWAL ( <i>Alternate II</i> )
Integrated Electric Company Private Limited, Bengaluru	DR PRAVEEN VIJAYRAGHAVAN
International Copper Association India, Mumbai	SHRI K. N. HEMANTH KUMAR SHRI JYOTISH PANDE ( <i>Alternate I</i> ) SHRI SANJAY NAMDEO ( <i>Alternate II</i> )
NTPC Limited, New Delhi	SHRI B. V. V. S. GANESH SHRI S. N. TRIPATHI ( <i>Alternate</i> )
Nuclear Power Corporation of India Limited, Mumbai	SHRI RITESH M. CHOVIATIA SHRI JAYANTH KUMAR BOPPA ( <i>Alternate</i> )
Scientific and Industrial Testing and Research Centre, Coimbatore	SHRI A. M. SELVARAJ DR K. ULAGANATHAN ( <i>Alternate I</i> ) SHRI V. KRISHNAMOORTHY ( <i>Alternate II</i> )
Siemens Limited, Mumbai	SHRI PRASAD HARDIKAR SHRI ASHISH SHERE ( <i>Alternate</i> )
Southern India Engineering Manufacturers Association, Coimbatore	DR R. SUBRAMANIAN SHRI S. ARUNKUMAR ( <i>Alternate</i> )

<i>Organization</i>	<i>Representative(s)</i>
Thyssenkrupp Industrial Solutions (India) Private Limited, Mumbai	SHRI CHARUTA VIKRAM MULAY SHRI VAJINATH G. SANGEKAR ( <i>Alternate</i> )
Toshiba Mitsubishi-Electric Industrial Systems Corporation, Bengaluru	SHRI SUDHEER TAPASKAR SHRI MANISH JOSHI ( <i>Alternate I</i> ) SHRI VENKATESULU THUMBUR ( <i>Alternate II</i> )
BIS Directorate General	SHRI ASIT KUMAR MAHARANA SCIENTIST 'E'/ DIRECTOR AND HEAD (ELECTROTECHNICAL) [REPRESENTING DIRECTOR GENERAL ( <i>Ex-officio</i> )]

*Member Secretary*  
JATIN TIWARI  
SCIENTIST 'B'/ASSISTANT DIRECTOR  
(ELECTROTECHNICAL), BIS





## Bureau of Indian Standards

BIS is a statutory institution established under the *Bureau of Indian Standards Act, 2016* to promote harmonious development of the activities of standardization, marking and quality certification of goods and attending to connected matters in the country.

### Copyright

BIS has the copyright of all its publications. No part of these publications may be reproduced in any form without the prior permission in writing of BIS. This does not preclude the free use, in the course of implementing the standard, of necessary details, such as symbols and sizes, type or grade designations. Enquiries relating to copyright be addressed to the Head (Publication & Sales), BIS.

### Review of Indian Standards

Amendments are issued to standards as the need arises on the basis of comments. Standards are also reviewed periodically; a standard along with amendments is reaffirmed when such review indicates that no changes are needed; if the review indicates that changes are needed, it is taken up for revision. Users of Indian Standards should ascertain that they are in possession of the latest amendments or edition by referring to the website-[www.bis.gov.in](http://www.bis.gov.in) or [www.standardsbis.in](http://www.standardsbis.in).

This Indian Standard has been developed from Doc No.: ETD 15 (17922).

### Amendments Issued Since Publication

Amend No.	Date of Issue	Text Affected

## BUREAU OF INDIAN STANDARDS

### Headquarters:

Manak Bhavan, 9 Bahadur Shah Zafar Marg, New Delhi 110002

Telephones: 2323 0131, 2323 3375, 2323 9402

Website: [www.bis.gov.in](http://www.bis.gov.in)

### Regional Offices:

Central : 601/A, Konnectus Tower -1, 6<sup>th</sup> Floor,  
DMRC Building, Bhavbhuti Marg, New  
Delhi 110002

Telephones

{ 2323 7617

Eastern : 8<sup>th</sup> Floor, Plot No 7/7 & 7/8, CP Block, Sector V,  
Salt Lake, Kolkata, West Bengal 700091

{ 2367 0012  
{ 2320 9474

Northern : Plot No. 4-A, Sector 27-B, Madhya Marg,  
Chandigarh 160019

{ 265 9930

Southern : C.I.T. Campus, IV Cross Road, Taramani, Chennai 600113

{ 2254 1442  
{ 2254 1216

Western : 5<sup>th</sup> Floor/MTNL CETTM, Technology Street, Hiranandani Gardens,  
Powai, Mumbai 400076

{ 2570 0030  
{ 2570 2715

**Branches :** AHMEDABAD, BENGALURU, BHOPAL, BHUBANESHWAR, CHANDIGARH, CHENNAI, COIMBATORE, DEHRADUN, DELHI, FARIDABAD, GHAZIABAD, GUWAHATI, HARYANA (CHANDIGARH), HUBLI, HYDERABAD, JAIPUR, JAMMU, JAMSHEDPUR, KOCHI, KOLKATA, LUCKNOW, MADURAI, MUMBAI, NAGPUR, NOIDA, PARWANOO, PATNA, PUNE, RAIPUR, RAJKOT, SURAT, VIJAYAWADA.