निम्न-वोल्टेज के स्विचगियर और नियंत्रण
गियर

भाग 7 सहायक उपकरण

अनुभाग 1 तांबे के कंडक्टरों के लिए टर्मिनल ब्लॉक

**Low-Voltage Switchgear and
Controlgear**

Part 7 Ancillary Equipment

**Section 1 Terminal Blocks for Copper
Conductors**

ICS 29.130.20

© BIS 2024

© IEC 2009



भारतीय मानक ब्यूरो

BUREAU OF INDIAN STANDARDS

मानक भवन, 9 बहादुर शाह ज़फर मार्ग, नई दिल्ली - 110002

MANAK BHAVAN, 9 BAHADUR SHAH ZAFAR MARG

NEW DELHI - 110002

www.bis.gov.in www.standardsbis.in

NATIONAL FOREWORD

This Indian Standard (Part 7/Sec 1) which is identical to IEC 60947-7-1 : 2009 'Low-voltage switchgear and controlgear — Part 7-1: Ancillary equipment — Terminal blocks for copper conductors' issued by the International Electrotechnical Commission (IEC) was adopted by the Bureau of Indian Standards on the recommendation of the Low Voltage Switchgear and Controlgear Sectional Committee and approval of the Electrotechnical Division Council.

This standard is published in various parts. Other parts in this series are:

- Part 1 General rules
- Part 2 Circuit-Breakers
- Part 3 Switches disconnectors switch-disconnectors and fuse-combination units
- Part 4 Contactors and motor-starters
- Part 5 Control circuit devices and switching elements
- Part 6 Multiple function equipment

The text of IEC standard has been approved as suitable for publication as an Indian Standard without deviations. Certain terminologies and conventions are, however, not identical to those used in Indian Standards. Attention is particularly drawn to the following:

- a) Wherever the words 'International Standard' appear referring to this standard, they should be read as 'Indian Standard'; and
- b) Comma (,) has been used as a decimal marker, while in Indian Standards the current practice is to use a point (.) as the decimal marker.

In this adopted standard, reference appears to International Standards for which Indian Standards also exist. The corresponding Indian Standards, which are to be substituted, are listed below along with their degree of equivalence for the editions indicated:

<i>International Standard</i>	<i>Corresponding Indian Standard</i>	<i>Degree of Equivalence</i>
IEC 60695-11-5 : 2004 Fire hazard testing — Part 11-5: Test flames — Needle-flame test method — Apparatus, confirmatory test arrangement and guidance	IS/IEC 60695-11-5 : 2016 Fire Hazard Testing: Part 11 Test Flames, Section 5 Needle — Flame test method — Apparatus, confirmatory test arrangement and guidance (<i>first revision</i>)	Identical to IEC 60695-11-5 : 2016
IEC 60947-1 : 2007 Low-voltage switchgear and controlgear — Part 1: General rules	IS/IEC 60947-1 : 2020 Low-voltage switchgear and controlgear: Part 1 General rules (<i>second revision</i>)	Identical to IEC 60947-1 : 2020

[*\(Continued on third cover\)*](#)

CONTENTS

1	General	1
1.1	Scope.....	1
1.2	Normative references	1
2	Definitions	2
3	Classification.....	2
4	Characteristics	2
4.1	Summary of characteristics	2
4.2	Type of terminal block	2
4.3	Rated and limiting values	3
4.3.1	Rated voltages	3
4.3.2	Short-time withstand current.....	3
4.3.3	Standard cross-sections	3
4.3.4	Rated cross-section.....	3
4.3.5	Rated connecting capacity.....	4
5	Product information	4
5.1	Marking	4
5.2	Additional information.....	4
6	Normal service, mounting and transport conditions.....	5
7	Constructional and performance requirements.....	5
7.1	Constructional requirements.....	5
7.1.1	Clamping units.....	5
7.1.2	Mounting	5
7.1.3	Clearances and creepage distances	5
7.1.4	Terminal identification and marking	5
7.1.5	Resistance to abnormal heat and fire.....	6
7.1.6	Rated cross-section and rated connecting capacity	6
7.2	Performance requirements	6
7.2.1	Temperature-rise	6
7.2.2	Dielectric properties.....	6
7.2.3	Short-time withstand current.....	6
7.2.4	Voltage drop.....	7
7.2.5	Electrical performance after ageing (for screwless-type terminal blocks only)	7
7.3	Electromagnetic compatibility (EMC)	7
8	Tests	7
8.1	Kinds of test	7
8.2	General	7
8.3	Verification of mechanical characteristics	8
8.3.1	General	8
8.3.2	Attachment of the terminal block on its support.....	8
8.3.3	Mechanical properties of clamping units	9
8.4	Verification of electrical characteristics.....	10
8.4.1	General	10
8.4.2	Verification of clearances and creepage distances	11
8.4.3	Dielectric tests.....	11

8.4.4	Verification of the voltage drop	11
8.4.5	Temperature-rise test	13
8.4.6	Short-time withstand current test	14
8.4.7	Ageing test (for screwless-type terminal blocks only).....	14
8.5	Verification of thermal characteristics	15
8.6	Verification of EMC characteristics	17
8.6.1	Immunity	17
8.6.2	Emission	17
Annex A	vacant.....	18
Annex B (informative)	Items subject to agreement between manufacturer and user	19
Annex C	vacant	20
Annex D (normative)	Additional requirements for test disconnect terminal blocks.....	21
Bibliography	29
Figure 1	– Arrangement for test according to 8.3.2	3
Figure 2	– Arrangement for tests according to 8.4.5 and 8.4.7, and for the verification of voltage drop.....	9
Figure 3	– Arrangement for test according to 8.5	11
Figure 4	– Point of test flame contact (view from the layer placed below the terminal block)	12
Figure D.1	– Test requirements according to D.8.4.4 for verification of the voltage drop	20
Table 1	– Standard cross-sections of round copper conductors.....	3
Table 2	– Relationship between rated cross-section and rated connecting capacity of terminal blocks	4
Table 3	– Attachment test parameters.....	9
Table 4	– Values of test current for temperature-rise test, ageing test and voltage drop verification for metric wire sizes	12
Table 5	– Values of test current for temperature-rise test, ageing test and voltage drop verification for AWG or kcmil wire sizes	13
Table D.1	– Operating cycles	23
Table D.2	– Values of test current for temperature-rise test, ageing test and voltage drop verification for metric wire sizes	25
Table D.3	– Values of test current for temperature-rise test, ageing test and voltage drop verification for AWG or kcmil wire sizes	25
Table D.4	– Short-time withstand current and corresponding wire sizes in mm ²	26
Table D.5	– Short-time withstand current and corresponding wire sizes in AWG	27

Indian Standard

**LOW-VOLTAGE SWITCHGEAR AND CONTROLGEAR
PART 7 ANCILLARY EQUIPMENT
SECTION 1 TERMINAL BLOCKS FOR COPPER CONDUCTORS**

1 General**1.1 Scope**

This part of IEC 60947 specifies requirements for terminal blocks with screw-type or screw-less-type clamping units primarily intended for industrial or similar use and to be fixed to a support to provide electrical and mechanical connection between copper conductors. It applies to terminal blocks intended to connect round copper conductors, with or without special preparation, having a cross-section between 0,2 mm² and 300 mm² (AWG 24/600 kcmil), intended to be used in circuits of a rated voltage not exceeding 1 000 V a.c. up to 1 000 Hz or 1 500 V d.c.

NOTE AWG is the abbreviation of "American Wire Gage" (Gage (US) = Gauge (UK))

kcmil = 1 000 cmil;

1 cmil = 1 circular mil = surface of a circle having a diameter of 1 mil

1 mil = 1/1 000 inch

This standard may be used as a guide for

- terminal blocks requiring the fixing of special devices to the conductors, for example quick connect terminations or wrapped connections, etc.;
- terminal blocks providing direct contact to the conductors by means of edges or points penetrating the insulation, for example insulation displacement connections, etc.;
- special types of terminal blocks, for example with diodes or varistors or similar component holders, etc.

Where applicable in this standard, the term "clamping unit" has been used instead of the term "terminal". This is taken into account in case of reference to IEC 60947-1.

1.2 Normative references

The following referenced documents are indispensable for the application of this document. For dated references, only the edition cited applies. For undated references, the latest edition of the referenced document (including any amendments) applies.

IEC 60695-11-5:2004, *Fire hazard testing – Part 11-5: Test flames – Needle-flame test method – Apparatus, confirmatory test arrangement and guidance*

IEC 60947-1:2007, *Low-voltage switchgear and controlgear – Part 1: General rules*

ISO 4046-4:2002, *Paper, board, pulp and related terms – Vocabulary – Part 4: Paper and board grades and covered products*

2 Definitions

For the purposes of this document, the definitions given in IEC 60947-1, together with the following definitions, apply.

2.1

terminal block

insulating part carrying one or more mutually insulated terminal assemblies and intended to be fixed to a support

2.2

rated cross-section

value of the maximum cross-section of all connectable types of conductors, rigid (solid and stranded) and flexible, stated by the manufacturer, and to which certain thermal, mechanical and electrical requirements are referred

2.3

rated connecting capacity

range of cross-sections and, if applicable, the number of connectable conductors, for which the terminal block is designed

2.4

terminal assembly

two or more clamping units fixed to the same conductive part

3 Classification

Distinction is made between various types of terminal blocks as follows:

- method of fixing the terminal block to the support;
- number of poles;
- type of clamping units: screw-type clamping units or screwless-type clamping units;
- ability to receive prepared conductors (see 2.3.27 of IEC 60947-1);
- terminal assemblies with identical or dissimilar clamping units;
- number of clamping units on each terminal assembly;
- service conditions.

4 Characteristics

4.1 Summary of characteristics

The characteristics of a terminal block are as follows:

- type of terminal block (see 4.2);
- rated and limiting values (see 4.3).

4.2 Type of terminal block

The following shall be stated:

- type of clamping units (e.g. screw-type, screwless-type);
- number of clamping units.

4.3 Rated and limiting values

4.3.1 Rated voltages

Subclauses 4.3.1.2 and 4.3.1.3 of IEC 60947-1 apply.

4.3.2 Short-time withstand current

A specified r.m.s. value of current which a terminal block shall be able to withstand during a specified short-time under prescribed conditions of use and behaviour (see 7.2.3 and 8.4.6).

4.3.3 Standard cross-sections

The standard values of cross-sections of round copper conductors to be used are contained in Table 1.

Table 1 – Standard cross-sections of round copper conductors

Metric size ISO mm ²	Comparison between AWG/kcmil and metric sizes	
	Size AWG/kcmil	Equivalent metric area mm ²
0,2	24	0,205
0,34	22	0,324
0,5	20	0,519
0,75	18	0,82
1	–	–
1,5	16	1,3
2,5	14	2,1
4	12	3,3
6	10	5,3
10	8	8,4
16	6	13,3
25	4	21,2
35	2	33,6
50	0	53,5
70	00	67,4
95	000	85
–	0000	107,2
120	250 kcmil	127
150	300 kcmil	152
185	350 kcmil	177
240	500 kcmil	253
300	600 kcmil	304

4.3.4 Rated cross-section

The rated cross-section shall be selected from the standard cross-sections given in Table 1.

4.3.5 Rated connecting capacity

For terminal blocks with a rated cross-section between 0,2 mm² and 35 mm² inclusive, the minimum range contained in Table 2 applies. The conductors may be rigid (solid or stranded) or flexible. The manufacturer shall state the types and the maximum and minimum cross-sections of conductors that can be connected and, if applicable, the number of conductors simultaneously connectable to each clamping unit. The manufacturer shall also state any necessary preparation of the end of the conductor.

Table 2 – Relationship between rated cross-section and rated connecting capacity of terminal blocks

Rated cross-section		Rated connecting capacity	
mm ²	AWG	mm ²	AWG
0,2	24	0,2	24
0,34	22	0,2 – 0,34	24 – 22
0,5	20	0,2 – 0,34 – 0,5	24 – 22 – 20
0,75	18	0,34 – 0,5 – 0,75	22 – 20 – 18
1	–	0,5 – 0,75 – 1	–
1,5	16	0,75 – 1 – 1,5	20 – 18 – 16
2,5	14	1 – 1,5 – 2,5	18 – 16 – 14
4	12	1,5 – 2,5 – 4	16 – 14 – 12
6	10	2,5 – 4 – 6	14 – 12 – 10
10	8	4 – 6 – 10	12 – 10 – 8
16	6	6 – 10 – 16	10 – 8 – 6
25	4	10 – 16 – 25	8 – 6 – 4
35	2	16 – 25 – 35	6 – 4 – 2

5 Product information

5.1 Marking

A terminal block shall be marked in a durable and legible manner with the following:

- the name of the manufacturer or a trade mark by which the manufacturer can be readily identified;
- a type reference permitting its identification in order to obtain relevant information from the manufacturer or his catalogue.

5.2 Additional information

The following information shall be stated by the manufacturer, if applicable, e.g. in the manufacturer's data sheet or his catalogue or on the packing unit:

- IEC 60947-7-1, if the manufacturer claims compliance with this standard;
- the rated cross-section;
- the rated connecting capacity, if different from Table 2, including the number of conductors simultaneously connectable;
- the rated insulation voltage (U_i);
- the rated impulse withstand voltage (U_{imp}), when determined;
- service conditions, if different from those of Clause 6;

g) conventional free air thermal current (I_{th}).

NOTE The conventional free air thermal current (I_{th}) is the maximum value of test current to be used for temperature-rise tests of unenclosed equipment in free air, see 4.3.2.1 of IEC 60947-1.

6 Normal service, mounting and transport conditions

Clause 6 of IEC 60947-1 applies.

7 Constructional and performance requirements

7.1 Constructional requirements

7.1.1 Clamping units

Subclause 7.1.8.1 of IEC 60947-1 applies with the following additions.

The clamping units shall allow the conductors to be connected by means ensuring that a reliable mechanical linkage and electrical contact is properly maintained.

NOTE Screw-type clamping units are not suitable for the connection of flexible conductors with tin soldered ends.

The clamping units shall be able to withstand the forces that can be applied through the connected conductors.

Compliance is checked by inspection and by the tests of 8.3.3.1, 8.3.3.2 and 8.3.3.3.

No contact pressure shall be transmitted through insulating materials other than ceramic, or other material with characteristics not less suitable, unless there is sufficient resiliency in the metallic parts to compensate for any possible shrinkage of the insulating material.

The corresponding test is under consideration.

7.1.2 Mounting

Terminal blocks shall be provided with means that allow them to be securely attached to a rail or a mounting surface.

Tests shall be made in accordance with 8.3.2.

NOTE Information on mounting on rails can be found in IEC 60715.

7.1.3 Clearances and creepage distances

For terminal blocks for which the manufacturer has stated values of rated impulse withstand voltage (U_{imp}) and rated insulation voltage (U_i), minimum values of clearances and creepage distances are given in Tables 13 and 15 of IEC 60947-1.

For terminal blocks for which the manufacturer has not declared a value of rated impulse withstand voltage (U_{imp}), guidance for minimum values is given in Annex H of IEC 60947-1.

Electrical requirements are given in 7.2.2.

7.1.4 Terminal identification and marking

Subclause 7.1.8.4 of IEC 60947-1 applies with the following addition.

A terminal block shall have provision, or at least space, for identification marks or numbers for each clamping unit or terminal assembly related to the circuit of which it forms a part.

For the identification of the terminal blocks the colour combination green-yellow is not allowed.

NOTE Such provision may consist of separate marking items, such as marking tags, identification labels, etc.

7.1.5 Resistance to abnormal heat and fire

The insulation materials of terminal blocks shall not be adversely affected by abnormal heat and fire.

Subclause 7.1.2.2 of IEC 60947-1 does not apply except for the Note.

Compliance is checked by the needle flame test according to IEC 60695-11-5 as specified in 8.5 of this standard.

7.1.6 Rated cross-section and rated connecting capacity

Terminal blocks shall be so designed that conductors of the rated cross-section and the rated connecting capacity, if applicable, can be accepted.

Compliance is checked by the test described in 8.3.3.4.

The verification of the rated cross-section may be performed by the special test according to 8.3.3.5.

7.2 Performance requirements

7.2.1 Temperature rise

Terminal blocks shall be tested in accordance with 8.4.5. The temperature-rise of the terminals shall not exceed 45 K.

7.2.2 Dielectric properties

If the manufacturer has declared a value of the rated impulse withstand voltage (U_{imp}) (see 4.3.1.3 of IEC 60947-1), the requirements of 7.2.3 and 7.2.3.1 of IEC 60947-1 apply. If applicable, the impulse withstand voltage test shall be carried out in accordance with 8.4.3 a).

For the verification of solid insulation, the requirements of 7.2.3, 7.2.3.2 and 7.2.3.5 of IEC 60947-1 apply. The power-frequency withstand voltage test shall be carried out in accordance with 8.4.3 b).

The verification of sufficient clearances and creepage distances shall be made in accordance with 8.4.2.

For terminal blocks for which the manufacturer has not declared a value of rated impulse withstand voltage (U_{imp}), guidance for minimum values is given in Annex H of IEC 60947-1.

7.2.3 Short-time withstand current

A terminal block shall be capable of withstanding for 1 s the short-time withstand current which corresponds to 120 A/mm² of its rated cross-section, in accordance with 8.4.6.

7.2.4 Voltage drop

The voltage drop on a terminal block caused by the conductor connection, measured according to 8.4.4, shall not exceed the values specified in 8.4.4 and, where applicable, in 8.4.7.

7.2.5 Electrical performance after ageing (for screwless-type terminal blocks only)

Terminal blocks shall be capable of withstanding the ageing test comprising 192 temperature cycles in accordance with 8.4.7.

7.3 Electromagnetic compatibility (EMC)

Subclause 7.3 of IEC 60947-1 applies.

8 Tests

8.1 Kinds of test

Subclause 8.1.1 of IEC 60947-1 applies with the following addition.

No routine tests are specified. The verification of the rated cross-section according to 8.3.3.5 is a special test. All other tests are type tests.

8.2 General

Unless otherwise specified, terminal blocks are tested in new and in clean condition, and installed as for normal use (see 6.3 of IEC 60947-1) at an ambient temperature of $(20 \pm 5) ^\circ\text{C}$.

NOTE "Normal use" means that five terminal blocks are mounted on their support, the remaining open side closed by an end plate and fixed by end brackets, if applicable.

The tests are carried out in the same order in which the subclauses describe them.

Each test is made on new separate specimens.

The tests of 8.3.3.2 and 8.3.3.3 are made on the same specimens.

The surface of the conductors shall be free of contamination and corrosion which degrades performance.

Care shall be taken when stripping conductors to avoid cutting, nicking, scraping or otherwise damaging the conductors.

In cases where the manufacturer has stated that special preparation of the end of the conductor is necessary, the test report shall indicate the method of preparation used.

The tests are carried out with the type of conductor (rigid or flexible) as stated by the manufacturer.

If one of the terminal blocks does not withstand one of the tests, this test shall be repeated on a second set of terminal blocks, all of which shall then comply with the repeated test. If this test is part of a test sequence, the complete test sequence shall be repeated.

8.3 Verification of mechanical characteristics

8.3.1 General

The verification of mechanical characteristics includes the following tests:

- attachment of the terminal block on its support (see 8.3.2);
- mechanical strength of clamping units (see 8.3.3.1);
- attachment of the conductors to the clamping units (see 8.3.3.2 and 8.3.3.3);
- rated cross-section and rated connecting capacity (see 8.3.3.4 and 8.3.3.5).

8.3.2 Attachment of the terminal block on its support

The test shall be made on two clamping units at the centre terminal block out of five terminal blocks mounted as in normal use on the appropriate support according to the manufacturer's instructions.

A steel pin of 150 mm length and of a diameter as specified in Table 3 is clamped successively in each clamping unit. The tightening torque shall be in accordance with Table 4 of IEC 60947-1 or, alternatively, in accordance with the higher torque value stated by the manufacturer. A force corresponding to the values of Table 3 is applied to the pin regularly and without shocks at a distance of 100 mm from the centre of the clamping unit, according to Figure 1.

During the test, no terminal block shall work free from its rail or support, nor suffer any other damage.

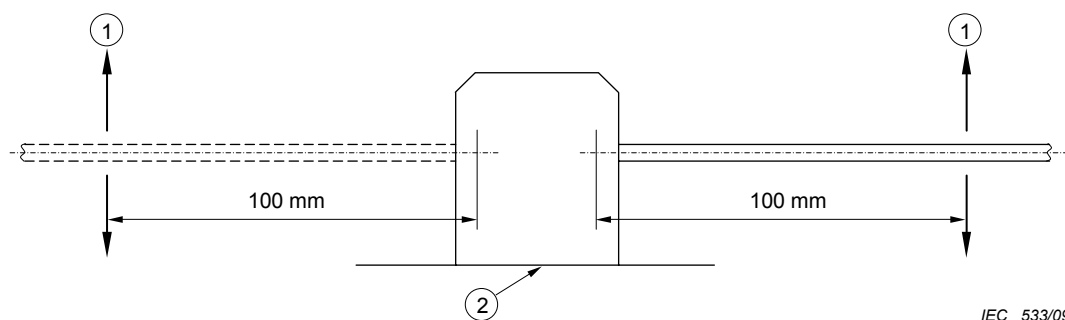

IEC 533/09

Key

- 1 Force
- 2 Rail or support

Figure 1 – Arrangement for test according to 8.3.2

Table 3 – Attachment test parameters

Rated cross-section of the terminal block		Force N	Diameter of pin mm
mm ²	AWG/kcmil		
0,2	24	1	1,0
0,34	22		
0,5	20		
0,75	18		
1,0	–		
1,5	16		
2,5	14		
4	12		
6	10	5	2,8
10	8		
16	6		
25	4	10	5,7
35	2		
50	0		
70	00		
95	000	15	12,8
–	0000		
120	250 kcmil		
150	300 kcmil		
185	350 kcmil		
240	500 kcmil	20	20,5
300	600 kcmil		

8.3.3 Mechanical properties of clamping units

8.3.3.1 Test of mechanical strength of clamping units

Subclauses 8.2.4.1 and 8.2.4.2 of IEC 60947-1 apply with the following addition.

The test shall be made on two clamping units at the centre terminal block out of five terminal blocks mounted as in normal use on the appropriate support according to the manufacturer's instructions.

After verification of the voltage drop according to 8.4.4 with a connected rigid conductor of the rated cross-section stated by the manufacturer and subsequently, if applicable, with a connected flexible conductor of the minimum cross-section stated by the manufacturer, rigid conductors of the rated cross-section shall be connected and disconnected five times each.

At the end of the test, the terminal blocks shall pass the voltage drop test according to 8.4.4 with a connected rigid conductor of the rated cross-section and subsequently, if applicable, with a connected flexible conductor of the minimum cross-section.

8.3.3.2 Testing for damage to and accidental loosening of conductors of a terminal block (flexion test)

Subclauses 8.2.4.1 and 8.2.4.3 of IEC 60947-1 apply with the following modification.

Each test shall be carried out on two clamping units of one terminal block.

The tightening torque shall be in accordance with Table 4 of IEC 60947-1 or alternatively in accordance with the higher torque value stated by the manufacturer.

The tests shall be made with the type (rigid and/or flexible) and the number of conductors stated by the manufacturer as follows:

- with the different types of conductor of the specified smallest cross-section (only one conductor connected);
- with the different types of conductor of the specified rated cross-section (only one conductor connected);

and, if applicable,

- with the type(s) of conductor of the largest connectable cross-section, if larger than the rated cross-section (only one conductor connected);
- with the different types and maximum number of conductors of the smallest cross-section simultaneously connectable;
- with the different types and maximum number of conductors of the largest cross-section simultaneously connectable;
- with the different types and maximum number of conductors of the smallest and largest cross-section simultaneously connectable.

8.3.3.3 Pull-out test

Subclause 8.2.4.4 of IEC 60947-1.

8.3.3.4 Verification of rated cross-section and rated connecting capacity

The test shall be carried out on each clamping unit of one terminal block.

For conductors of the rated cross-section and for terminal blocks with a rated connecting capacity up to 35 mm², one conductor of the two next smaller cross-sections shall be inserted unhindered in the opened clamping unit and be connected.

Theoretical diameter of the largest conductor is given in Table 7a of IEC 60947-1.

8.3.3.5 Verification of rated cross-section (special test with gauges)

Subclause 8.2.4.5 of IEC 60947-1 applies with the following addition.

The test shall be carried out on each clamping unit of one terminal block.

8.4 Verification of electrical characteristics

8.4.1 General

The verification of electrical characteristics includes the following:

- verification of clearances and creepage distances (see 8.4.2);
- dielectric test (see 8.4.3);
- verification of the voltage drop (see 8.4.4);
- temperature-rise test (see 8.4.5);
- short-time withstand current test (see 8.4.6);
- ageing test for screwless-type terminal blocks only (see 8.4.7).

8.4.2 Verification of clearances and creepage distances

8.4.2.1 General

The verification is made between two adjacent terminal blocks and between a terminal block and the metal support to which the terminal blocks are attached.

The measurement of clearances and creepage distances shall be made under the following conditions:

- a) the terminal blocks shall be wired with the most unfavourable conductor type(s) and conductor cross-section(s) among those declared by the manufacturer;
- b) the conductor ends shall be stripped to a length specified by the manufacturer;
- c) in case the manufacturer has stated the possibility of using different metal supports, the most unfavourable support shall be used.

The method of measuring clearances and creepage distances is given in Annex G of IEC 60947-1.

8.4.2.2 Clearances

The measured values of clearances shall be higher than the values given in Table 13 of IEC 60947-1 for case B – homogeneous field (see 7.2.3.3 of IEC 60947-1) depending on the value of the rated impulse withstand voltage (U_{imp}) and the pollution degree stated by the manufacturer.

The impulse withstand voltage test shall be carried out in accordance with 8.4.3 a) unless the measured clearances are equal to or larger than the values given in Table 13 of IEC 60947-1 for case A – inhomogeneous field (see 8.3.3.4.1, item 2), of IEC 60947-1).

8.4.2.3 Creepage distances

The measured creepage distances shall be not less than the values given in table 15 of IEC 60947-1 in connection with 7.2.3.4 a) and b) of IEC 60947-1 depending on the rated insulation voltage (U_i), the material group and the pollution degree as specified by the manufacturer.

8.4.3 Dielectric tests

- a) If the manufacturer has declared a value for the rated impulse withstand voltage U_{imp} , the impulse withstand voltage test shall be made in accordance with 8.3.3.4.1, item 2), of IEC 60947-1, except item 2) c) which does not apply.
- b) The power-frequency withstand verification of solid insulation shall be made in accordance with 8.3.3.4.1, item 3), of IEC 60947-1. The value of the test voltage shall be as stated in Table 12A of IEC 60947-1 (see 8.3.3.4.1, item 3) b) i), of IEC 60947-1).

Each test shall be carried out on five adjacent terminal blocks wired and installed on a metal support under conditions a), b) and c) indicated in 8.4.2.1.

The test voltage shall be applied first between the adjacent terminal blocks and then between all terminal blocks connected together and the support to which the terminal blocks are attached.

8.4.4 Verification of the voltage drop

The voltage drop shall be verified

- a) before and after the test of mechanical strength of clamping units (see 8.3.3.1);
- b) before and after the temperature-rise test (see 8.4.5);

- c) before and after the short-time withstand current test (see 8.4.6);
- d) before, during and after the ageing test (see 8.4.7).

The verification is made as specified in 8.3.3.1, 8.4.5, 8.4.6 and 8.4.7.

The voltage drop is measured on each terminal block as Indicated in Figure 2. The measurement is made with a direct current of 0,1 times the value given in Table 4 or Table 5.

Before the tests according to a), b), c) and d) above, the voltage drop shall not exceed

- 3,2 mV, or
- 1,6 mV on each individual clamping unit when measured separately, only if the overall measured value in Figure 2 exceeds 3,2 mV.

If the measured value exceeds 3,2 mV, the voltage drop is determined on each individual clamping unit separately, which shall not exceed 1,6 mV.

After the tests according to a), b) and c), the voltage drop shall not exceed 150 % of the values measured before the test.

During and after the test according to d), the voltage drop measured shall not exceed the values specified in 8.4.7.

Table 4 – Values of test current for temperature-rise test, ageing test and voltage drop verification for metric wire sizes

Rated cross-section mm²	0,2	0,34	0,5	0,75	1	1,5	2,5	4	6	10	16
Test current A	4	5	6	9	13,5	17,5	24	32	41	57	76
Rated cross-section mm²	25	35	50	70	95	120	150	185	240	300	
Test current A	101	125	150	192	232	269	309	353	415	520	

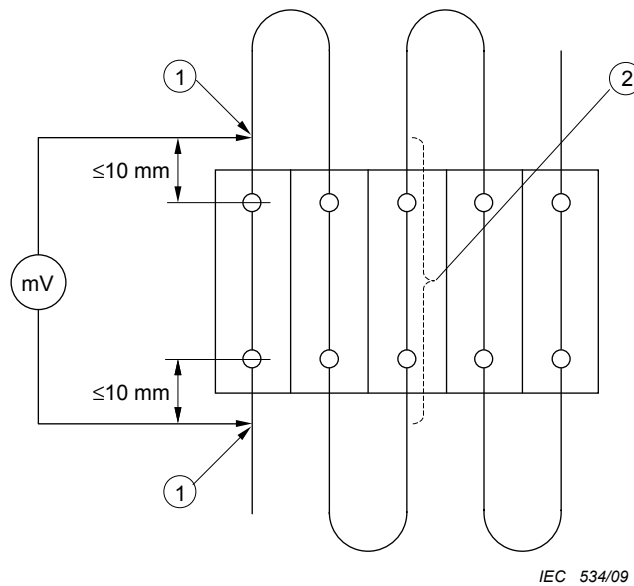
**Key**

- 1 Measuring point of voltage drop
- 2 Measuring of temperature

Figure 2 – Arrangement for tests according to 8.4.5 and 8.4.7, and for the verification of voltage drop

Table 5 – Values of test current for temperature-rise test, ageing test and voltage drop verification for AWG or kcmil wire sizes

Rated cross-section AWG	24	22	20	18	16	14	12	10	8	6	4
Test current A	4	6	8	10	16	22	29	38	50	67	90
Rated cross-section AWG or kcmil	2	1	0	00	000	0000	250 kcmil	300 kcmil	350 kcmil	500 kcmil	600 kcmil
Test current A	121	139	162	185	217	242	271	309	353	415	520

8.4.5 Temperature-rise test

The test is made simultaneously on five adjacent terminal blocks connected in series by PVC-insulated conductors of the rated cross-section, as shown in Figure 2. The tightening torque shall be in accordance with Table 4 of IEC 60947-1 or alternatively in accordance with the higher torque value stated by the manufacturer. The minimum length of each of the six conductors shall be 1 m for rated cross-sections up to and including 10 mm² (AWG 8), and 2 m for larger rated cross-sections.

The test circuit shall be located horizontally on a wooden surface as shown in Figure 2 (e.g. table top or floor), the terminal blocks being securely fixed to this surface and the conductors lying freely on it.

If the rated cross-section is below 10 mm² (AWG 8), the conductors shall be solid. For rated cross-sections equal to or higher than 10 mm² (AWG 8), the conductors shall be rigid stranded.

During the test, screws of clamping units shall not be retightened.

After verification of the voltage drop according to 8.4.4, the test is made with a.c. single-phase current as given in Table 4 or Table 5 according to the rated cross-section, and is continued until steady temperature is reached. A variation of less than 1 K between any two out of three consecutive measurements made at an interval of 5 min is considered as steady temperature.

For multi-tier terminal blocks, the test is made either with an a.c. single-phase current as given in Table 4 or Table 5, or with the conventional free air thermal current (I_{th}) specified by the manufacturer.

The temperature-rise of any part of the centrally located terminal block shall not exceed the limit given in 7.2.1 (see Figure 2).

At the end of the test, after cooling down to ambient air temperature and without any change in the arrangement, the terminal blocks shall pass the voltage drop test according to 8.4.4.

8.4.6 Short-time withstand current test

The purpose of this test is to verify the ability to withstand a thermal shock.

The test is performed on one terminal block installed according to the manufacturer's instructions. The tightening torque shall be in accordance with Table 4 of IEC 60947-1 or alternatively in accordance with the higher torque value stated by the manufacturer.

If the rated cross-section is below 10 mm² (AWG 8), the conductors shall be solid. For rated cross-sections equal to or higher than 10 mm² (AWG 8), the conductors shall be rigid stranded.

After verification of the voltage drop according to 8.4.4, the value and the duration of the test current shall be in accordance with 7.2.3.

At the end of the test, continuity shall exist on the test sample assembly and the terminal blocks shall not show any cracking, breakage or other critical damage. After cooling down to ambient temperature and without any change in the arrangement, the terminal block shall pass the voltage drop test according to 8.4.4.

8.4.7 Ageing test (for screwless-type terminal blocks only)

The test is made simultaneously on five adjacent terminal blocks connected in series by conductors of the rated cross-section, as shown in Figure 2.

If the rated cross-section is below 10 mm² (AWG 8), the conductors shall be solid. For rated cross-sections equal to or higher than 10 mm² (AWG 8), the conductors shall be rigid stranded.

For terminal blocks intended for use under "normal service conditions" (maximum 40 °C according to 6.1.1 of IEC 60947-1), PVC-insulated conductors shall be used.

For terminal blocks for which the manufacturer has specified "maximum service conditions above 40 °C" (see 6.1.1, note 1, of IEC 60947-1), heat-resistant, insulated or non-insulated conductors shall be used.

The minimum length of the conductor bridges shall be 300 mm.

The terminal blocks are placed in a heating cabinet which is initially kept at a temperature of (20 ± 2) °C and then submitted to the verification of the voltage drop test.

The whole test arrangement, including the conductors, shall not be moved until the voltage drop test has been completed.

The terminal blocks are submitted to 192 temperature cycles as follows.

The temperature in the heating cabinet is increased to 40 °C according 8.3.3.3.1 of IEC 60947-1 or to the temperature value declared by the manufacturer for “maximum service conditions”.

The temperature is maintained within ± 5 °C of this value for approximately 10 min.

During this test period the current according to 8.4.5 is applied.

The terminal blocks are then cooled down to a temperature of approximately 30 °C, forced cooling being allowed; they are kept at this temperature for approximately 10 min and, if necessary for measuring the voltage drop, it is allowed to cool down further to a temperature of (20 ± 5) °C.

NOTE As a guide, a value for the heating and cooling rate of the heating cabinet of approximately 1,5 °C/min may be taken as a basis.

The voltage drop on each terminal block is also determined according to 8.4.4 after each of 24 temperature cycles and after the 192 temperature cycles have been completed, each time at a temperature of (20 ± 5) °C.

In no case the voltage drop shall exceed 4,8 mV or 1,5 times the value measured after the 24th cycle, whichever is the lower.

After this test, a visual inspection shall show no changes impairing further use such as cracks, deformations or the like.

Furthermore, the pull-out test according to 8.3.3.3 shall be carried out.

8.5 Verification of thermal characteristics

The thermal characteristics are checked by the needle flame test.

The test is carried out according to IEC 60695-11-5 successively in the area of one clamping unit of three terminal blocks.

The test room shall be substantially draught-free with dimensions sufficient to ensure an adequate supply of air.

Before the test, the terminal blocks are stored for 24 h in an atmosphere having a temperature between 15 °C and 35 °C and a relative humidity between 45 % and 75 %.

After this preconditioning, the terminal block is mounted on its appropriate support and fixed with suitable means so that one lateral insulation wall lies parallel to the layer placed below it (see Figure 3).

Conductors are not connected.

The layer placed below, which consists of an approximately 10 mm thick pinewood board covered with a single layer of tissue paper (grammage between 12 g/m² to 30 g/m² according to 4.215 of ISO 4046-4:2002, is positioned at a distance of (200 ± 5) mm below the terminal block.

The test flame, adjusted in accordance with Figure 1a) of IEC 60695-11-5, is guided under an angle of 45° to the lateral insulation wall.

The tip of the flame shall make contact with the insulation wall in the area of the clamping unit (see Figure 4).

The flame is applied for 10 s. For insulation walls <1 mm and/or an area <100 mm², the flame is applied for 5 s.

After the flame is removed, the duration of burning in the case of ignition is measured.

Duration of burning denotes the time interval from the moment the flame is removed until flames or glowing of the terminal block have extinguished.

The terminal blocks are considered to have passed the test if the duration of burning is <30 s in case of ignition.

Moreover, the tissue paper on the pinewood board shall not ignite if burning or glowing particles fall from the terminal block.

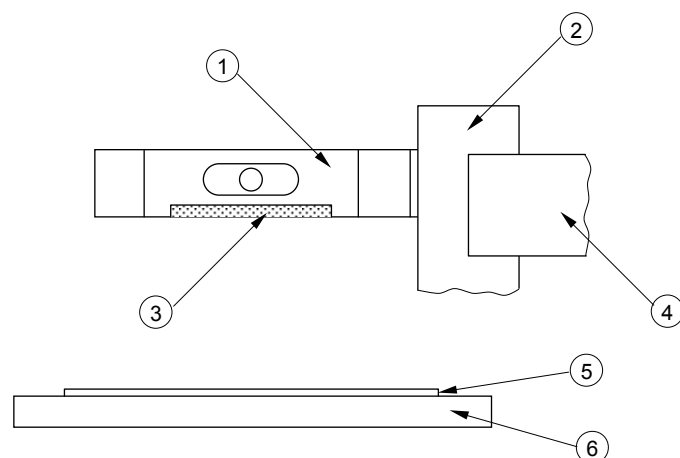

IEC 535/09

Key

- 1 Terminal block
- 2 Support of the terminal block
- 3 Lateral insulation wall
- 4 Fixing means
- 5 Tissue paper
- 6 Pinewood board

Figure 3 – Arrangement for test according to 8.5

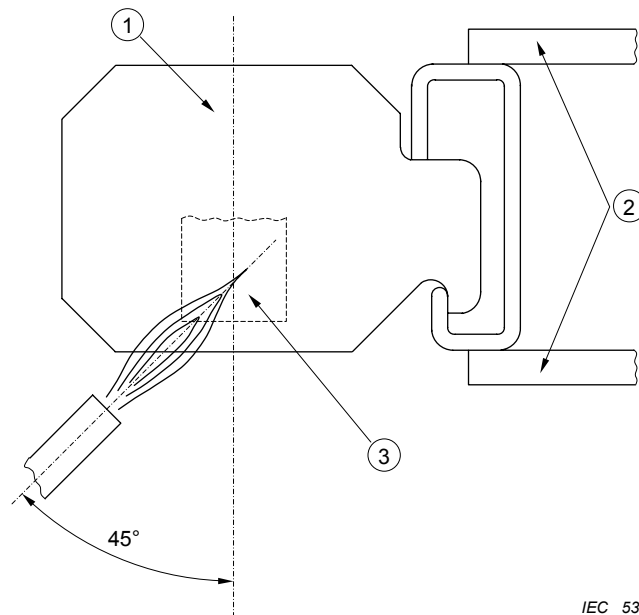
**Key**

- 1 Terminal block
- 2 Fixing means
- 3 Clamping part in the area of the damping unit

**Figure 4 – Point of test flame contact
(view from the layer placed below the terminal block)**

8.6 Verification of EMC characteristics

Subclause 8.4 of IEC 60947-1 applies with the following addition.

8.6.1 Immunity

Terminal blocks within the scope of this standard are not sensitive to electromagnetic disturbances and therefore no immunity tests are necessary.

8.6.2 Emission

Terminal blocks within the scope of this standard do not generate electromagnetic disturbances and therefore no emission tests are necessary.

Annex A
Vacant

Annex B (informative)

Items subject to agreement between manufacturer and user

NOTE For the purpose of this annex, the word “agreement” is used in a very wide sense; the word “user” includes testing stations.

Annex J of IEC 60947-1 applies, as far as is covered by clauses and subclauses of this standard, with the following additions:

Clause or subclause number of this standard	Point
8.2	Test conductors: – special preparation of the end, if needed – type (flexible, rigid)
8.3.3.1	Smallest connectable cross-section for the voltage drop verification
8.3.2 } 8.3.3 } 8.4.5 } 8.4.6 }	Tightening torque for securing the test conductors, if different from the values given in table 4 of IEC 60947-1
8.3.3.5	Special test
8.4.7	Temperature for the ageing test, if different from +40 °C
NOTE All the above items are, where applicable, stated by the manufacturer.	

Annex C
Vacant

Annex D (normative)

Additional requirements for test disconnect terminal blocks

D.1 Scope

This annex specifies the requirements for test disconnect terminal blocks which are intended to accommodate conductors having a cross section between 0,2 mm² and 35 mm². These terminal blocks are intended to be used in power and control circuits for temporary disconnection (for testing purposes) at zero potential and at no load.

D.2 Terms and definitions

Clause 2 applies with the following additions:

D.2.1

test disconnect terminal block

terminal block with one or more clamping units and disconnect unit(s) in the current circuit for temporary opening and closing of power and control circuits at zero potential for testing and measuring purposes

D.2.2

longitudinal disconnection

disconnection of a circuit within a terminal block or from a terminal block to a busbar within a terminal assembly (see Figure D.1a)

D.2.3

perpendicular disconnection

disconnection between several circuits of adjacent test disconnect terminal blocks or terminal blocks (see Figure D.1b)

D.3 Classification

Clause 3 applies with the following addition:

- longitudinal disconnection
- perpendicular disconnection.

D.4 Characteristics

Clause 4 applies with the following addition.

D.4.2 Type of terminal block

- type of disconnection/disconnecting function (e. g. screw-type disconnect slide or screwless-type disconnect slide, disconnect knife, etc.)

D.5 Product information

Clause 5 applies with the following addition:

- h) service life in number of cycles.

D.6 Normal service, mounting and transport conditions

Clause 6 applies.

D.7 Constructional and performance requirements

Clause 7 applies with the following addition.

D.7.1 Constructional requirements

D.7.1.3 Clearances and creepage distances

Creepage and clearance distances are not required to be measured over the open disconnect contacts (gap).

However, the rated impulse withstand voltage (U_{imp}) stated by the manufacturer according to Table 13 of IEC 60947-1, without using the altitude correction factor, shall be verified across the open disconnect contacts (gap).

D.7.1.7 Disconnect unit

For longitudinal and perpendicular disconnection, test disconnect terminal blocks may be equipped with disconnect units, for instance of the following type:

- plug;
- knife;
- slide (with or without busbar).

The position of the disconnect unit shall be recognizable in normal use and shall not be changed unintentionally.

D.7.2 Performance requirements

D.7.2.1 Temperature rise

Test disconnect terminal blocks shall be tested in accordance with D.8.4.5. The temperature rise of any part of the terminal blocks shall not exceed 45 K.

D.7.2.2 Dielectric properties

Subclause 7.2.2 applies except for open disconnect contacts (gap) for which the following specification applies.

The value of the rated impulse withstand voltage (U_{imp}) stated by the manufacturer shall be verified by the impulse withstand voltage test according to IEC 60947-1, Table 13 without using the altitude correction factor.

When the manufacturer has not declared a value of rated impulse withstand voltage (U_{imp}), guidance for minimum values is given in Annex H of IEC 60947-1.

D.7.2.3 Short-time withstand current

The text of 7.2.3 is supplemented by the following:

If the manufacturer has declared a conventional free air thermal current (I_{th}) value for the test disconnect terminal block, the terminal block shall be capable of withstanding for 1 s the short-time withstand current at a current density of 120 A/mm² with respect to the corresponding conductor cross-section according to D.8.4.6.

D.7.2.4 Voltage drop

The voltage drop on a test disconnect terminal block, measured according to D.8.4.4, shall not exceed the values given in D.8.4.4 and, where applicable, in D.8.4.7.

D.7.2.5 Electrical performance after ageing (for test disconnect terminal blocks with screwless-type clamping units only)

Subclause 7.2.5 applies with the following addition.

If the manufacturer has declared a current value for the test disconnect terminal block, D.8.4.7 applies.

D.7.2.6 Service life

Test disconnect terminal blocks shall sufficiently withstand mechanical and thermal conditioning which may appear in normal use.

For the mechanical actuation of the disconnect units, the information given by the manufacturer shall be considered. Preferred values for the number of operating cycles are given in Table D.1.

Compliance is checked in accordance with D.8.5.1.

Table D.1 – Operating cycles

Preferred number
10
50
100
500
1 000

D.8 Tests

Clause 8 applies with the following modifications:

D.8.4.4 Verification of the voltage drop

The text of 8.4.4 is replaced by the following.

The voltage drop shall be verified:

- a) before and after the test of mechanical strength of clamping units (see 8.3.3.1);
- b) before and after the temperature-rise test (see 8.4.5);
- c) before and after the short-time withstand current test (see 8.4.6 or D.8.4.6 if the manufacturer has declared a current value);
- d) before, during and after the ageing test (see 8.4.7 or D.8.4.7 if the manufacturer has declared a current value);
- e) before and after the life test (see D.8.5.1).

The verification is made as specified in 8.3.3.2, D.8.4.5, 8.4.6 or D.8.4.6 and 8.4.7 or D.8.4.7.

The voltage drop is measured on each terminal block as indicated in Figure D.1. The measurement is made with a direct current. The measuring current is 0,1 times the value of the test current given in Table D.2 or D.3.

Before the tests according to a), b), c), d) and e), the voltage drop on the test disconnect terminal block shall not exceed 1,6 mV times the total number of conductor clamping unit and disconnect unit contact points. If the measured value exceeds this calculated value, the voltage drop is measured on each individual conductor clamping unit and disconnect unit contact point. It shall not exceed 1,6 mV on any conductor clamping unit or disconnect unit contact point.

After the tests according to a), b), c) and e), the voltage drop shall not exceed 150 % of the values measured before the test.

During and after the tests according d), the voltage drop measured shall not exceed the values specified in D.8.4.7.

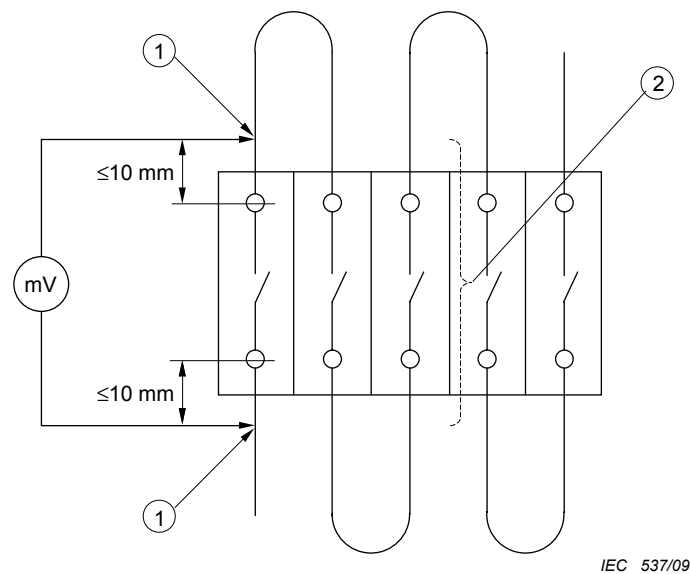

Figure D.1a – Verification of the voltage drop for longitudinal disconnection within the terminal block

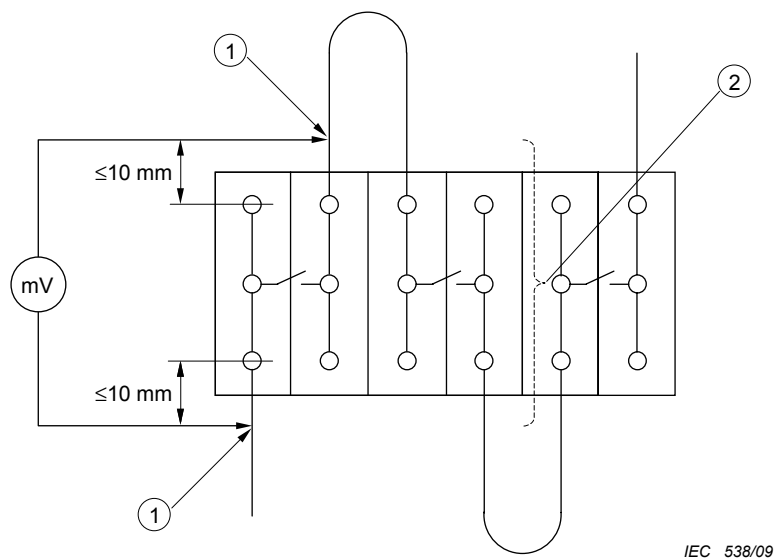

Figure D.1b – Verification of the voltage drop for perpendicular disconnection

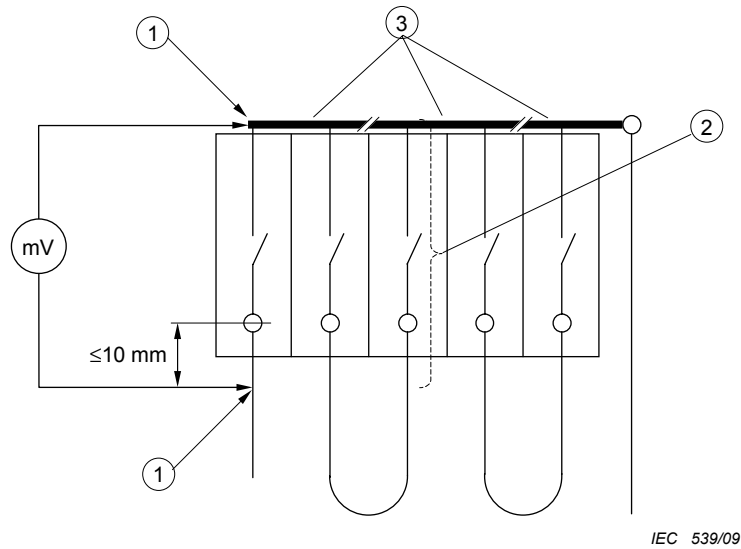

Figure D.1c – Verification of the voltage drop for direct longitudinal disconnection to the busbar

Key

- 1 Measuring point of voltage drop
- 2 Measuring of temperature
- 3 Busbar sections

Figure D.1 – Test requirements according to D.8.4.4 for verification of the voltage drop

Table D.2 – Values of test current for temperature-rise test, ageing test and voltage drop verification for metric wire sizes

Rated cross-section mm ²	0,2	0,34	0,5	0,75	1	1,5	2,5	4	6	10	16	25	35
Test current A	4	5	6	9	13,5	17,5	24	32	41	57	76	101	125

Table D.3 – Values of test current for temperature-rise test, ageing test and voltage drop verification for AWG or kcmil wire sizes

Rated cross-section AWG	24	22	20	18	16	14	12	10	8	6	4	2
Test current A	4	6	8	10	16	22	29	38	50	67	90	121

D.8.4.5 Temperature-rise test

Subclause 8.4.5 applies with the following modification of the first paragraph.

The test is made simultaneously on adjacent test disconnect terminal blocks connected in series by PVC-insulated conductors of the rated cross-section, as shown in Figure D.1. The conductors on terminal blocks with screw-type clamping units and screw-type disconnect units shall be tightened with a torque according to Table 4 of IEC 60947-1 or alternatively in accordance with the higher torque value stated by the manufacturer. If the manufacturer has declared a conventional free air thermal current (I_{th}) value for the test disconnect terminal

block, the test is made with a.c. single-phase current according to this value. Otherwise the test is made with an a.c. single-phase current as given in Table D.2 or Table D.3.

D.8.4.6 Short-time withstand current test

The purpose of this test is to verify the ability to withstand a thermal shock.

The test is performed on one test disconnect terminal block installed according to the manufacturer's instructions.

The conductor cross-section with which the terminal is wired and the short-time withstand current shall be taken from Table D.4 or Table D.5.

Conductors on terminal blocks with screw-type clamping units and screw-type disconnect units, if applicable, shall be tightened with a torque according to Table 4 of IEC 60947-1 or alternatively in accordance with the higher torque value stated by the manufacturer.

If the conductor cross-section is below 10 mm² (AWG 8), the conductors shall be solid. For conductor cross-sections equal to or higher than 10 mm² (AWG 8), the conductors shall be rigid stranded.

After verification of the voltage drop according to D.8.4.4, the test shall be performed with a short-time withstand current as specified above and with a duration according to D.7.2.3.

At the end of the test no damage that may impair further use shall have occurred to any part of the test disconnect terminal block. After cooling down to ambient temperature and without any change in the arrangement, the test disconnect terminal block shall pass the voltage drop test according to D.8.4.4.

Table D.4 – Short-time withstand current and corresponding wire sizes in mm²

Current as stated by the manufacturer A	Corresponding conductor cross-section mm ²	Short-time withstand current (120 A/ mm ²) A
0 < I ≤ 4	0,2	24
4 < I ≤ 5	0,34	40,8
5 < I ≤ 6	0,5	60
6 < I ≤ 9	0,75	90
9 < I ≤ 13,5	1	120
13,5 < I ≤ 17,5	1,5	180
17,5 < I ≤ 24	2,5	300
24 < I ≤ 32	4	480
32 < I ≤ 41	6	720
41 < I ≤ 57	10	1 200
57 < I ≤ 76	16	1 920
76 < I ≤ 101	25	3 000
101 < I ≤ 125	35	4 200

Table D.5 – Short-time withstand current and corresponding wire sizes in AWG

Current as stated by the manufacturer A	Corresponding conductor cross-section AWG	Short-time withstand current (120 A/mm ²) A
$0 < I \leq 4$	24	24,6
$4 < I \leq 6$	22	38,9
$6 < I \leq 8$	20	62,3
$8 < I \leq 10$	18	98,4
$10 < I \leq 16$	16	156
$16 < I \leq 22$	14	252
$22 < I \leq 29$	12	396
$29 < I \leq 38$	10	636
$38 < I \leq 50$	8	1 008
$50 < I \leq 67$	6	1 596
$67 < I \leq 90$	4	2 544
$90 < I \leq 121$	2	4 032

D.8.4.7 Ageing test for test disconnect terminal blocks with screwless-type clamping units

Subclause 8.4.7 applies with the following additions. During this test period the current according to D.8.4.5 is applied. Screw-type disconnect units shall be tightened with a torque according to Table 4 of IEC 60947-1 or, if applicable, a higher value stated by the manufacturer.

For this test, the voltage drop shall be measured on each individual conductor clamping unit according to Figure D.1.

In no case the voltage drop on each individual conductor clamping unit shall exceed 2,4 mV or 1,5 times the value measured after the 24th cycle, whichever is the lower.

D.8.5 Verification of thermal characteristics

Subclause 8.5 applies with the following addition.

D.8.5.1 Service life

The test shall be performed on adjacent test disconnect terminal blocks connected in series by conductors of the rated cross-section as shown in Figure D.1.

Screw-type disconnect units shall be tightened with a torque according to Table 4 of IEC 60947-1 or, if applicable, a higher value stated by the manufacturer.

The tightening torque shall be in accordance with Table 4 of IEC 60947-1 or alternatively in accordance with the higher torque value stated by the manufacturer

After verification of the voltage drop according to D.8.4.4, the disconnect units of the specimens are disconnected and connected one after the other, as intended in normal use, at zero potential with the number of operating cycles stated by the manufacturer.

The entire test apparatus is then stored for 168 h in dry heat at a temperature of 85 °C.

At the end of the test after cooling down to ambient temperature and without any change in the arrangement, the specimens shall pass the voltage drop test according to D.8.4.4.

D.8.6 Verification of EMC characteristics

Subclause 8.6 applies.

Bibliography

IEC 60228, Conductors of insulated cables

IEC/TR 60344, Calculation of d.c. resistance of plain and coated copper conductors of low-frequency cables and wires –Application guide

IEC 60715, Dimensions of low-voltage switchgear and controlgear – Standardized mounting on rails for mechanical support of electrical devices in switchgear and controlgear installations

ASTM B 172-71 (Re-approved 1985), *Standard specification for rope – Lay-stranded copper conductors having bunch-stranded members, for electrical energy*

ICEA Publication S-19-81 (6th edition) / NEMA Publication WC 3-1980 – Rubber insulated wire and cable for the transmission and distribution of electrical energy

ICEA Publication S-66-524 (2nd edition) / NEMA Publication WC 7-1982 – Cross-linked thermosetting polyethylene insulated wire and cable for the transmission and distribution of electrical energy

ICEA Publication S-68-516 / NEMA Publication WC 8-1976 – Ethylene propylene-rubber-insulated wire and cable for the transmission and distribution of electrical energy

[\(Continued from second cover\)](#)

The Committee has reviewed the provisions of the following international standards referred in this adopted standard and decided that they are acceptable for use in conjunction with this standard.

<i>International Standard</i>	<i>Title</i>
ISO 4046-4 : 2002	Paper, board, pulp and related terms — Vocabulary — Part 4: Paper and board grades and covered products

Only the English language text has been retained while adopting it in this Indian Standard, and as such, the page numbers given here are not the same as in the IEC publication.

For the purpose of deciding whether a particular requirement of this standard is complied with the final value, observed or calculated expressing the result of a test or analysis shall be rounded off in accordance with IS 2 : 2022 'Rules for rounding of numerical values (*second revision*)'. The number of significant places retained in the rounded off value should be the same as that of the specified value in this standard.

Bureau of Indian Standards

BIS is a statutory institution established under the *Bureau of Indian Standards Act, 2016* to promote harmonious development of the activities of standardization, marking and quality certification of goods and attending to connected matters in the country.

Copyright

BIS has the copyright of all its publications. No part of these publications may be reproduced in any form without the prior permission in writing of BIS. This does not preclude the free use, in the course of implementing the standard, of necessary details, such as symbols and sizes, type or grade designations. Enquiries relating to copyright be addressed to the Head (Publication & Sales), BIS.

Review of Indian Standards

Amendments are issued to standards as the need arises on the basis of comments. Standards are also reviewed periodically; a standard along with amendments is reaffirmed when such review indicates that no changes are needed; if the review indicates that changes are needed, it is taken up for revision. Users of Indian Standards should ascertain that they are in possession of the latest amendments or edition by referring to the website-www.bis.gov.in or www.standardsbis.in.

This Indian Standard has been developed from Doc No.: ETD 07 (24761).

Amendments Issued Since Publication

Amend No.	Date of Issue	Text Affected

BUREAU OF INDIAN STANDARDS

Headquarters:

Manak Bhavan, 9 Bahadur Shah Zafar Marg, New Delhi 110002

Telephones: 2323 0131, 2323 3375, 2323 9402

Website: www.bis.gov.in

Regional Offices:

Central : 601/A, Konnectus Tower -1, 6th Floor,
DMRC Building, Bhavbhuti Marg, New
Delhi 110002

Telephones

{ 2323 7617

Eastern : 8th Floor, Plot No 7/7 & 7/8, CP Block, Sector V,
Salt Lake, Kolkata, West Bengal 700091

{ 2367 0012
2320 9474

Northern : Plot No. 4-A, Sector 27-B, Madhya Marg,
Chandigarh 160019

{ 265 9930

Southern : C.I.T. Campus, IV Cross Road, Taramani, Chennai 600113

{ 2254 1442
2254 1216

Western : 5th Floor/MTNL CETTM, Technology Street, Hiranandani Gardens, Powai
Mumbai 400076

{ 25700030
25702715

Branches : AHMEDABAD, BENGALURU, BHOPAL, BHUBANESHWAR, CHANDIGARH, CHENNAI, COIMBATORE, DEHRADUN, DELHI, FARIDABAD, GHAZIABAD, GUWAHATI, HARYANA (CHANDIGARH), HUBLI, HYDERABAD, JAIPUR, JAMMU, JAMSHEDPUR, KOCHI, KOLKATA, LUCKNOW, MADURAI, MUMBAI, NAGPUR, NOIDA, PARWANOO, PATNA, PUNE, RAIPUR, RAJKOT, SURAT, VIJAYAWADA.