

सतह सक्रिय अभिकर्मक —
परीक्षण पद्धतियाँ
भाग 3 फोमिंग पावर
(पहला पुनरीक्षण)

Surface Active Agents —
Methods of Test
Part 3 Foaming Power
(First Revision)

ICS 71.100.40

© BIS 2024



भारतीय मानक ब्यूरो
BUREAU OF INDIAN STANDARDS
मानक भवन, 9 बहादुर शाह ज़फर मार्ग, नई दिल्ली - 110002
MANAK BHAVAN, 9 BAHADUR SHAH ZAFAR MARG
NEW DELHI - 110002

www.bis.gov.in www.standardsbis.in

FOREWORD

This Indian Standard (Part 3) (First Revision) was adopted by the Bureau of Indian Standards after the draft finalized by the Soaps, Detergents and Surface Active Agents Sectional Committee had been approved by the Chemical Division Council.

For a practical and realistic evaluation of quality of the class of products known as surface active agents, performance tests constitute the ideal yardstick. Physico-chemical analysis alone is inadequate. While uniform procedures have been evolved for carrying out these tests, the results obtained are not reproducible. Measurement of the foaming power of solutions of readily hydrolysable surface active agents by the methods given in the standard does not give reliable results, as the hydrolysis products collect in the films of liquid and affect the persistence of the foam. The persistence of liquid films is very sensitive to the presence of particles of insoluble matter. This method of measurement of foaming power should be used only with the greatest of care, for measuring the foaming power of compositions based on surface active agents of which the solubility is rarely complete. Foaming power is also very sensitive to small variations in composition. Consequently, the results obtained on formulated products should be interpreted with caution.

The sectional committee responsible for the preparation of this standard, therefore, felt that publication of the test methods in the form of an Indian Standards would promote adoption of uniform practices within the country. The test methods, which are based on available data and current practices, are expected to be revised from time to time to improve their precision and accuracy.

This standard (Part 3) was first published in 1970. In this revision, the following changes have been incorporated;

- a) The Scope has been modified;
- b) The test method has been updated by including the commercially available Ross-Miles foam apparatus for measuring foaming power;
- c) In addition, the provision has been added of running the test at the relevant concentration at which the product is intended to work; and
- d) Instruction has been added to note the calcium to magnesium molar ratio in the water being used in the preparation of sample solution.
- e) Reporting clause has been modified.
- f) Amendment no. 1 has also been incorporated.

This Indian Standard is published in several parts. The other parts of the standard are:

- Part 1 Relative dispersing power
- Part 2 Relative emulsifying power
- Part 4 Relative detergency
- Part 5 Wetting power

The composition of the committee responsible for the formulation of this standard is given in [Annex A](#).

In reporting the result of a test or analysis made in accordance with this standard, is to be rounded off, it shall be done in accordance with IS 2 : 2022 'Rules for rounding off numerical values (*second revision*).

*Indian Standard***SURFACE ACTIVE AGENTS — METHODS OF TEST****PART 3 FOAMING POWER***(First Revision)***1 SCOPE**

1.1 This standard (Part 3) prescribes two methods, method A and method B, for the measurement of the foaming power of a surface active agent. These methods are applicable to all surface active agents.

1.2 The methods are not applicable for measurement of the foaming power of very dilute solutions of surface active agents, such as river water containing surface active agents.

1.3 In cases of dispute, method A known as ross-miles method, is the referee method.

2 TERMINOLOGY

For the purpose of this standard, the following definitions shall apply:

2.1 Foaming Power — Ability to produce foam. Foaming power is characterized by the volume of foam obtained under specific experimental conditions. The decay of this volume of foam during the five minutes following its formation is also relevant.

2.2 Foam — A mass of small gas cells, separated by thin films of liquid and formed by the juxtaposition of bubbles, giving a gas dispersed in a liquid.

3 METHOD A (ROSS-MILES METHOD)**3.1 Apparatus****3.1.1 Pipette**

The pipette as shown in [Fig. 1](#), shall be constructed from standard-wall, chemically resistant glass tubing having the following dimensions:

- a) For the bulb, 45.0 mm \pm 1.5 mm outside diameter; and
- b) For the lower stem, 7.0 mm \pm 0.5 mm outside diameter.

3.1.2 The upper stem shall be constructed to contain a solid-stopper, straight bore, No. 2, standard taper stopcock having a 2 mm bore and stems 8 mm in outside diameter. Both the upper seals and lower seals of the bulb to the stems shall be hemispherical in shape. The lower stem shall be 60 mm \pm 2 mm in length from the point of attachment to the bulb and

shall contain an orifice sealed into the lower end. The orifice shall be constructed from precision bore tubing having an inside diameter of 2.90 mm \pm 0.02 mm and a length of 10.00 mm \pm 0.05 mm, with both ends ground square. The orifice shall have an outside diameter so as to fit snugly into the lower stem and form a secure seal to the stem when heated with a sharp pointed flame in the blow torch. The pipette shall be calibrated to contain 200.0 ml \pm 0.2 ml at 20 °C. The calibration mark shall be on the upper stem at least 15 mm below the barrel of the stopcock and shall completely encircle the stem.

3.1.2 Receiver

The receiver as shown in [Fig. 2](#), constructed from standard-wall, chemically resistant glass tubing having an internal diameter of 50.0 mm \pm 0.8 mm, with one end constricted and sealed to a straight-bore solid-plug, standard-taper No. 6 stopcock having a 6 mm bore and 12 mm stems. The receiver shall have three calibration marks which shall completely encircle the tube. The first mark shall be at the 50 ml point, shall be measured with the stopcock closed, and shall not be on any curved portion of the constriction. The second mark shall be at the 250 ml point and the third mark at a distance of 90.0 cm \pm 0.5 cm above the 50 ml mark. The receiver tube shall be mounted in a standard-wall tubular water jacket, having an external diameter of not less than 70 mm, fitted with inlet and outlet connections. The jacket may be attached to the receiver with rubber stoppers or may be sealed at the top and bottom. The seal at the bottom shall be as close to the barrel of the stopcock as practicable. The assembled receiver and, jacket shall be mounted securely in a plumb position and the jacket connected to a source of water thermostatically maintained at 48.0 °C \pm 0.5 °C for circulating through the jacket. At the top of the receiver, there shall be a platform, flush with the top of the assembly, having a metal plate in which is drilled three indexing holes circumferentially placed around the receiver and having an angular displacement of 120° from each other. A clamp which, may be securely attached to the upper part of the pipette, shall fit into the holes. The clamp shall have three leveling screws and lock nuts and when properly mounted shall exactly centre the pipette in the receiver and bring the lower tip of the pipette level with the upper calibration mark on the receiver.

A metre stick shall be fastened to the side or behind the receiver with the zero-point level with the 250 ml calibration point on the receiver.

3.2 Alternatively, Ross-Miles Foam test apparatus are commercially available and may be used to conduct this test, provided they meet the specified dimensions for length and diameters of all parts. More modern equipment may also measure foam height electronically.

3.3 Preparation of Sample Solution

Distilled water, or water of various degrees of hardness, may be used for this test. Adequate care should be taken to note the calcium to magnesium molar ratio in the water hardness. Preheat the water used for preparing the solution and add slowly, while carefully stirring, an amount of the surface active agent that will produce the desired concentration. Continue stirring in such a manner as to avoid excessive foam formation, until solution of the surface active agent is complete. Age the solution at a temperature of $48.0\text{ }^{\circ}\text{C} \pm 0.5\text{ }^{\circ}\text{C}$ for a total period of 30 min, counting the time when the surface active agent is first added to the water.

3.4 Procedure

While the surface active solution is aging, circulate water at $48.0\text{ }^{\circ}\text{C} \pm 0.5\text{ }^{\circ}\text{C}$ through the water jacket of

the receiver so as to bring it to the proper temperature. Rinse down the walls of the receiver with distilled water and, as an indication of cleanliness, observe whether the water drains down the walls in an unbroken film. At the completion of the aging period close the stopcock at the bottom of the receiver. Rinse the walls of the receiver with 50 ml of the solution, using a pipette, and, after draining to the bottom of the receiver, adjust the stopcock so that the level of the solution, in the receiver is exactly at the 50 ml mark. Fill the pipette with the solution to the 200 ml mark, using a slight suction for the purpose. Immediately, place it in position at the top of the receiver and open the stopcock. When all of the solution has run out of the pipette, start a stop-watch, take a reading of the foam height and take a second reading at the end of 5 min. Take the reading by measuring the foam production at the top of the foam column at the highest average height to which the rim of the foam has reached. This height is proportional to the volume of air remaining in the foam.

NOTE — It is desirable to conduct this test at a number of concentrations, the lowest of which shall be chosen to show a foam height which shall be no higher than 20 percent of the foam height shown at the highest concentration. It is also recommended to include in the test a relevant concentration that matches the one achieved with the recommended dosage of the surface active agent in typical wash concentrations of the different applications.

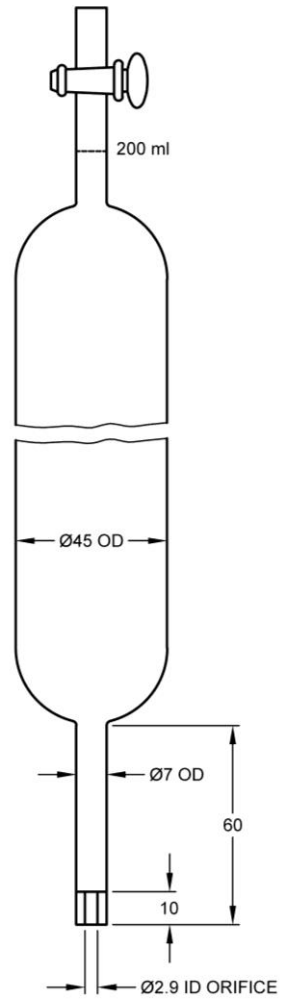

All dimensions in millimetres.
FIG. 1 FOAM PIPETTE

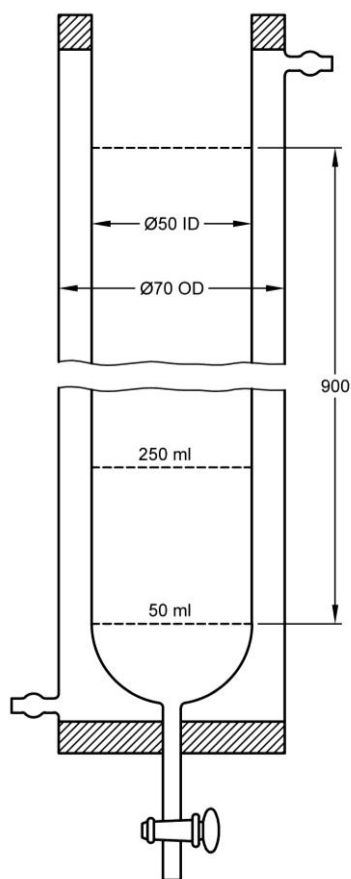

All dimensions in millimetres.
FIG. 2 FOAM RECIEVER

3.5 Reporting

3.5.1 The test report shall indicate the method used and the results obtained. It shall also mention:

- Concentration in grams per litre;
- The temperature of the test;
- The degree of hardness of the water;
- Ca : Mg ratio; and
- The initial foam height reading.

3.5.2 Finally, all operational details not already given in this standard, or regarded as optional, together with any other incidents which may have affected the results, should be reported.

3.5.3 The report should include all details required for complete identification of the sample.

4 METHOD B

4.1 Outline of Method

The volume of foam obtained after running 500 ml of a solution of a surface active agent, from a height of 450 mm, on to a liquid surface of the same

solution is measured under prescribed conditions.

4.2 Apparatus

4.2.1 Assembly of Apparatus

The apparatus as shown in [Fig. 3](#), consists of the following parts:

- Separating funnel, capacity of 1 litre, consisting of a pear-shaped bulb to the upper end of a tube about 200 mm long, having a tap at the lower end. The funnel carries a mark, 150 mm above the axis of the tap, which indicates the lower limit of discharge during the test. The lower end of the tube is cut off strictly perpendicular to its length, 40 mm below the axis of the tap. The tap is moulded, not blown, the hole through the key being of sufficient diameter (not less than 3 mm) to avoid undue obstruction of the flow of the liquid;
- Graduated measuring cylinder, capacity of 1 litre. The measuring cylinder stands in a water bath fitted with a thermostat, the bath being sufficiently large to accommodate

the measuring cylinder immersed up to half its height;

- c) A stand comprising a vertical rod, sufficiently long to allow the separating funnel and the measuring cylinder to be held in place. To ensure that the assembly is centered and so maintained during the measurement, the separating funnel is held by means of two rings, one supporting the spherical part, the other of much smaller diameter placed as low as possible around the stem of the separating funnel, below the tap. The measuring cylinder is held in place by means of a screw clamp with one moveable jaw; and
- d) Stainless steel metering tube, 70 mm long, $1.90 \text{ mm} \pm 0.02 \text{ mm}$ internal diameter and 0.3 mm wall thickness. The ends of the tube should be cut accurately at right angles to the axis of the tube, in a precision tool lathe. The metering tube is a push fit in a steel mounting tube 5 mm to 10 mm long, of internal diameter equal to the external diameter of the metering tube, and of external diameter equal to that of the lower end of the glass tube of the separating funnel. The upper ends of the metering tube and of mounting tube should be in the same plane. The mounting tube is fixed by means of a short length of thick rubber tube (vacuum tubing) so that the upper end of the mounting tube is in contact with the lower end of the glass tube.

4.2.2 Cleaning of Apparatus

Before the test, and, if possible, overnight, leave all glassware in contact with chromic-sulphuric acid mixture, prepared by slowly stirring concentrated sulphuric acid into an equal volume of a saturated solution of potassium bichromate. Rinse the apparatus first in distilled water until free from acid and then with a small quantity of the solution under test.

4.2.2.1 Keep the mounting tube and metering tube assembly for 30 min in the vapour of an azeotropic mixture of ethanol and trichloroethylene, then rinse it with a small quantity of the solution under test.

4.2.2.2 Between each measurement, of the same product, simply rinse the apparatus with the solution under test. When it is required to remove the foam remaining in the measuring cylinder, no matter what method is employed to do so, follow by a rinse with the solution under test.

NOTE — Adequate cleanliness of the apparatus is essential for success in the test.

4.3 Preparation of Solution

4.3.1 Prepare a solution of the material at the working strength. The water used for dilution may be either distilled water saturated with air by bubbling, or hard water containing 300 parts per millions of calcium carbonate. Prepare the solution by pasting and then dissolution in the chosen water, previously warmed to $50 \text{ }^\circ\text{C}$. It is necessary to mix very gently to prevent the formation of foam. Keep the solution at $50 \text{ }^\circ\text{C} \pm 2 \text{ }^\circ\text{C}$, without stirring, until the test is made. The age of the solution, at the time of the measurement, should be not less than 30 min nor greater than 2 h.

4.3.2 Other conditions than those specified above (for example, hardness of the water, temperature) may be chosen provided that they are mentioned in the test report.

4.4 Procedure

4.4.1 Assembling the Apparatus

The apparatus shall be assembled in a place free from draughts. Adjust the thermostat of the water bath to bring the temperature of the bath to $50 \text{ }^\circ\text{C} \pm 2 \text{ }^\circ\text{C}$. Introduce 50 ml of the solution, prepared as described in [4.3](#), into the measuring cylinder, running it down the inside wall so that no foam is formed on its surface. Place the measuring cylinder in the water bath and hold it in place by means of the screw clamp. The separating funnel should be mounted in such a way that the lower end of the metering tube is co-incident with a fixed mark on the graduated cylinder, 20 mm from the top of the cylinder. This would ensure that flow of the solution from the separating funnel into measuring cylinder is not disturbed by air currents and continues along a straight path.

NOTE — The dimensions underlined are obligatory.

4.4.2 Filling the Apparatus

4.4.2.1 For the first measurement, introduce part of the test solution into the separating funnel up to the 150 mm mark. To do this, immerse the lower end of the metering tube in a portion of the test solution maintained at $50 \text{ }^\circ\text{C} \pm 2 \text{ }^\circ\text{C}$ in a beaker and aspirate the liquid by suitable means attached to the top of the bulb. This is the most certain way to avoid the formation of air bubbles in the hole through the key of the tap. The beaker is kept below the separating funnel until the measurement is made. To complete the filling, pour 500 ml of the test solution, maintained at $50 \text{ }^\circ\text{C} \pm 2 \text{ }^\circ\text{C}$, into the separating funnel from the 500 ml graduated cylinder, performing this operation gently to avoid the formation of foam. This may be achieved by the use of a special funnel with a curved stem, the end of which touches the interior wall of the separating funnel.

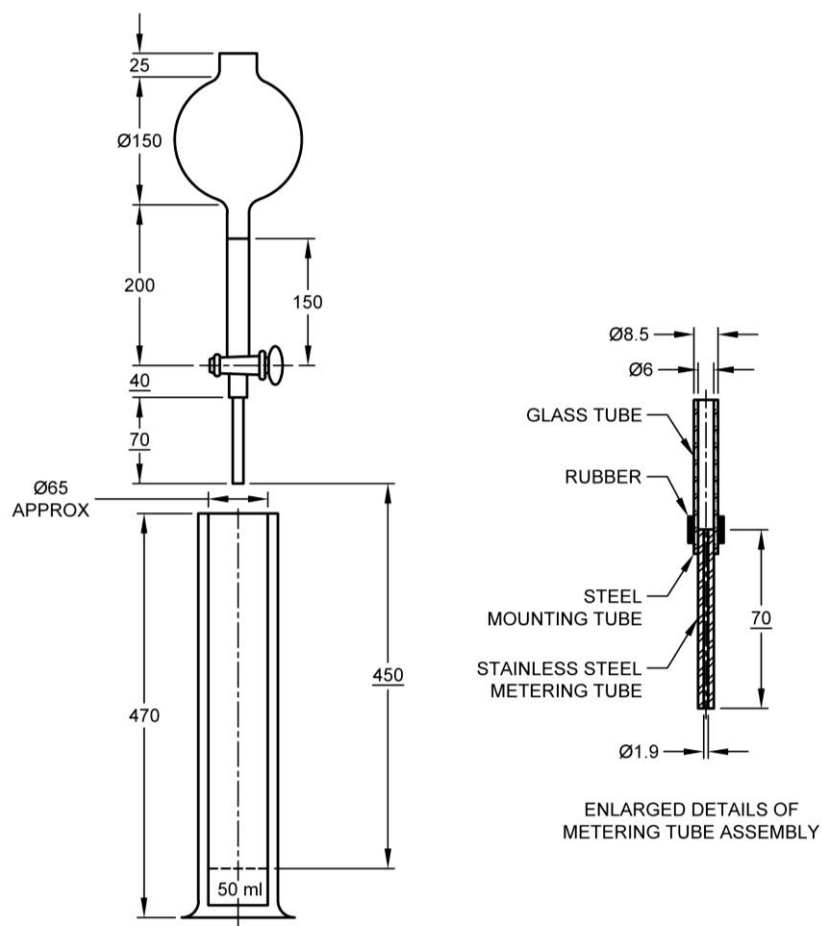

All dimensions in millimetres.

FIG. 3 FOAMING TEST APPARATUS (METHOD B)

4.4.2.2 For subsequent measurements, drain the separating funnel down to a height of 1 cm to 2 cm above the tap. Place the beaker full of the test solution, kept at $50\text{ }^{\circ}\text{C} \pm 2\text{ }^{\circ}\text{C}$, under the separating funnel as before. Fill the separating funnel with the test solution up to the 150 mm mark, then pour in 500 ml of the test solution, maintained at $50\text{ }^{\circ}\text{C} \pm 2\text{ }^{\circ}\text{C}$, as described above.

NOTE — Filling to the 150 mm mark may also be achieved by not allowing the separating funnel to empty completely after the previous filling with the test solution. This simpler method gives less guarantee of freedom from air bubbles.

4.4.3 Measurement

Allow the solution to flow, without interruption, until the level falls to the 150 mm mark. Note the time of efflux. All measurements in which the time of efflux differs by more than 5 percent from the arithmetic mean of previously observed efflux times should be neglected, an abnormally long time indicating the presence of an air bubble in the metering tube or in the tap. Measure the volume of

foam (only the foam) at 30 s, 3 min, and 5 min after the efflux has been stopped.

4.4.3.1 If the upper level of the foam has a depression in the centre, record the reading as the arithmetic mean between the centre and the edges.

NOTE — It may be of assistance, in making this measurement, to use a white varnished slip carrying a longitudinal black varnished line. This slip is placed in the foam generated in the receiving cylinder and the lower level of the volume of foam to be measured is taken at the point where contrast between black and white is visible.

4.4.3.2 Repeat the measurement ten times, preparing a fresh solution each time as described in [4.3.1](#). Take the arithmetic mean of at least 8 results.

4.5 Expression of Results and Reporting

4.5.1 Express the results in millilitres of foam formed at 30 s, 3 min and 5 min after stopping the efflux. Then draw the corresponding curve.

4.5.2 The test report shall indicate the method used and the results obtained. It shall also mention:

- a) The concentration of the test solution, expressed in grams of surface active agent per litre;
- b) The temperature in degrees celsius during the test, if it is different from that recommended (*see Note*); and
- c) The hardness of the water actually used, expressed in parts of calcium carbonate per million, if this differs from that recommended.

NOTE — Curves showing the variation of foaming power as a function of temperature differ considerably, according to the products examined, in slope as well as in variety. A comparison of several surface active agents, according to their foaming power, cannot, therefore, be carried out unless this curve is prepared or at least three points upon it are given.

4.5.3 Finally, all operational details not already given in this standard, or regarded as optional, together with any other incidents which may have affected the results, should be reported.

4.5.4 The report should include all details required for complete identification of the sample.

ANNEX A

(Foreword)

COMMITTEE COMPOSITION

Soaps, Detergents and Surface Active Agents Sectional Committee, CHD 25

<i>Organization</i>	<i>Representative(s)</i>
Harcourt Butler Technical University, Kanpur	PROF R. K. TRIVEDI (<i>Chairperson</i>)
Central Drugs Standard Control Organization, New Delhi	SHRIMATI SHRADDHA SRIVASTAVA SHRI BALJEET SINGH (<i>Alternate I</i>) SHRI GAJANAN YADAVRAO MODHE (<i>Alternate II</i>)
Central Pollution Control Board, New Delhi	SHRI DINABANDHU GOUDA SHRI A. SUDHAKAR (<i>Alternate</i>)
Consumer Guidance Society of India, Mumbai	DR SITARAM DIXIT SHRI B. V. DESAI (<i>Alternate</i>)
Consumer Voice, New Delhi	SHRI M. A. U. KHAN SHRI B. K. MUKHOPADHYAY (<i>Alternate</i>)
Dabur India Limited, Sahibabad	SHRI AMIT SIRDESAI SHRI RAVI TRIPATHI (<i>Alternate</i>)
Directorate General of Quality Assurance, CQA (Textiles and Clothing), Kanpur	SHRI A. K. PATRA DR S. K. PANDEY (<i>Alternate</i>)
FASSSDMI, Delhi	SHRI ASEEM GALHOTRA
Fena Private Limited, New Delhi	SHRI DALIP JOLLY SHRI BENNY G. JACOB (<i>Alternate</i>)
Godrej Consumer Products Limited, Mumbai	DR MANOJ GAUR SHRI VENKATESWARA YADLAPALLI (<i>Alternate I</i>) SHRIMATI RUPINDER KAUR RAWAT (<i>Alternate II</i>)
Harcourt Butler Technical University, Kanpur	DR P. K. S. YADAV DR VINAYA TIWARI (<i>Alternate</i>)
Hindustan Unilever Limited, Mumbai	DR A. SIVAKUMAR SHRIMATI SEEMA YADAV (<i>Alternate I</i>) SHRIMATI PRITI CHODANKAR (<i>Alternate II</i>)
Indian Home and Personal Care Industry Association, Mumbai	SHRI SANJAY N. TRIVEDI SHRI ANOOP MISHRA (<i>Alternate</i>)
Indian Oil Corporation Limited, Mumbai	DR Y. S. JHALA SHRI RISHIKESH PRAJAPATI (<i>Alternate I</i>) SHRI ALOK SRIVASTAVA (<i>Alternate II</i>)
Institute of Chemical Technology, Mumbai	DR AMIT P. PRATAP DR R. D. KULKARNI (<i>Alternate</i>)
ITC Limited, Kolkata	SHRI AVISEK MUKHOPADHYAY DR DOSS JAYAPRAKASH (<i>Alternate</i>)

Micro, Small and Medium Enterprises, Technology Development Centre, New Delhi	SHRI MANOJ KUMAR SHRI VIPUL GAIKWAD (<i>Alternate</i>)
Ministry of Commerce and Industry, Department for Promotion of Industry and Internal Trade, New Delhi	SHRI NAND LAL SHRI N. C. TIWARI (<i>Alternate</i>)
National Institute of Technology Arunachal Pradesh, Yupia	DR KARTICK MONDAL
National Test House, Kolkata	SHRI AVINASH KUMAR DR (SHRIMATI) MADHURIMA MISHRA (<i>Alternate</i>)
Novozymes South Asia Private Limited, Mumbai	DR VASUDHEVA REDDY SHRI NARESH RAGHAVAN (<i>Alternate</i>)
Oil Technologists' Association of India, Kanpur	SHRI ASHOK MAHINDRU PROF (DR) G. A. USMANI (<i>Alternate</i>)
Procter and Gamble India, Mumbai	SHRI GIRISH PARHATE SHRI SIVAKUMAR THANIGACHALAM (<i>Alternate</i>)
Reckitt Benckiser India Private Limited, Mumbai	SHRI RUCHIR SHAH SHRIMATI JASMIN KALRA (<i>Alternate</i>)
BIS Directorate General	SHRI AJAY KUMAR LAL, SCIENTIST 'F'/SENIOR DIRECTOR AND HEAD (CHEMICAL) [REPRESENTING DIRECTOR GENERAL (<i>Ex-officio</i>)]

Member Secretary
MISS SRISHTI DIXIT
SCIENTIST 'D'/JOINT DIRECTOR
(CHEMICAL), BIS

Bureau of Indian Standards

BIS is a statutory institution established under the *Bureau of Indian Standards Act, 2016* to promote harmonious development of the activities of standardization, marking and quality certification of goods and attending to connected matters in the country.

Copyright

BIS has the copyright of all its publications. No part of these publications may be reproduced in any form without the prior permission in writing of BIS. This does not preclude the free use, in the course of implementing the standard, of necessary details, such as symbols and sizes, type or grade designations. Enquiries relating to copyright be addressed to the Head (Publication & Sales), BIS.

Review of Indian Standards

Amendments are issued to standards as the need arises on the basis of comments. Standards are also reviewed periodically; a standard along with amendments is reaffirmed when such review indicates that no changes are needed; if the review indicates that changes are needed, it is taken up for revision. Users of Indian Standards should ascertain that they are in possession of the latest amendments or edition by referring to the website-www.bis.gov.in or www.standardsbis.in.

This Indian Standard has been developed from Doc No.: CHD 25 (19459).

Amendments Issued Since Publication

Amend No.	Date of Issue	Text Affected

BUREAU OF INDIAN STANDARDS

Headquarters:

Manak Bhavan, 9 Bahadur Shah Zafar Marg, New Delhi 110002

Telephones: 2323 0131, 2323 3375, 2323 9402

Website: www.bis.gov.in

Regional Offices:

	Telephones
Central : 601/A, Konnectus Tower -1, 6 th Floor, DMRC Building, Bhavbhuti Marg, New Delhi 110002	{ 2323 7617
Eastern : 8 th Floor, Plot No 7/7 & 7/8, CP Block, Sector V, Salt Lake, Kolkata, West Bengal 700091	{ 2367 0012 2320 9474
Northern : Plot No. 4-A, Sector 27-B, Madhya Marg, Chandigarh 160019	{ 265 9930
Southern : C.I.T. Campus, IV Cross Road, Taramani, Chennai 600113	{ 2254 1442 2254 1216
Western : 5 th Floor/MTNL CETTM, Technology Street, Hiranandani Gardens, Powai Mumbai 400076	{ 25700030 25702715

Branches : AHMEDABAD, BENGALURU, BHOPAL, BHUBANESHWAR, CHANDIGARH, CHENNAI, COIMBATORE, DEHRADUN, DELHI, FARIDABAD, GHAZIABAD, GUWAHATI, HARYANA (CHANDIGARH), HUBLI, HYDERABAD, JAIPUR, JAMMU, JAMSHEDPUR, KOCHI, KOLKATA, LUCKNOW, MADURAI, MUMBAI, NAGPUR, NOIDA, PARWANOO, PATNA, PUNE, RAIPUR, RAJKOT, SURAT, VIJAYAWADA.