

भारतीय मानक

IS 3972 (Part 2/Sec 12) : 2024

Indian Standard

विट्रियस एनामेलवेयर
भाग 2 परीक्षण पद्धतियाँ
अनुभाग 12 ऐठन का प्रतिरोध
(दूसरा पुनरीक्षण)

Vitreous Enamelware
Part 2 Test Methods
Section 12 Resistance to Torsion
(*Second Revision*)

ICS 25.220.50, 97.040.60

© BIS 2024



भारतीय मानक ब्यूरो
BUREAU OF INDIAN STANDARDS
मानक भवन, 9 बहादुर शाह ज़फर मार्ग, नई दिल्ली - 110002
MANAK BHAVAN, 9 BAHADUR SHAH ZAFAR MARG
NEW DELHI - 110002
www.bis.gov.in www.standardsbis.in

October 2024

Price Group 6

FOREWORD

This Indian Standard (Second Revision) was adopted by the Bureau of Indian Standards, after the draft finalized by the Ceramicware Sectional Committee had been approved by the Chemical Division Council.

This standard was first published in in 1968. The committee while reviewing IS 3972 : 1968 decided to publish this standard in two parts. Part 1 deals with production of specimens for testing. Part 2 deals with various test methods applicable to vitreous enamelled sheet steel and vitreous enamelled cast iron. The committee also decided that Part 2 shall have various sections and each section will deal with a particular test method.

This section (Part 2/Sec 12) prescribes the method for determination of resistance of vitreous enamelware to torsion. It covers a procedure for evaluating the relative resistance to failure under torsion, of vitreous enamelled test specimens prepared either from different enamels or from the same enamel processed under different conditions.

The laboratory torsion test data correlate well with tensional stress on vitreous enamelled ware subjected to distortion through bending or twisting, or a combination of both.

The first revision of this standard was brought out in 1999. Now, the committee decided to revise the standard with a view to update it based on the experience of last two decades and on the currently available data.

The other sections of Part 2 are as follows:

Section 2	Low and high voltage test for detection and locating defects
Section 3	Resistance to boiling acids, boiling liquids, alkaline liquids and their vapours
Section 4	Resistance to thermal shock
Section 5	Resistance to hot alkali (sodium hydroxide)
Section 6	Reflectance and specular gloss
Section 8	Resistance to heat
Section 9	Resistance to dilute sulphuric acid
Section 11	Resistance to abrasion
Section 13	Resistance to warpage
Section 14	Resistance to adherence

Section 1, Section 3 and Section 7 of this standard IS 3972 (Part 2) have been merged and published as IS 3972 (Part 2/ Sec 3).

The composition of the Committee, responsible for the formulation of this standard is given in [Annex A](#).

In reporting the result of a test or analysis made in accordance with this standard, if the final value, observed or calculated, is to be rounded off, it shall be done in accordance with IS 2 : 2022 'Rules for rounding off numerical values (*second revision*)'.

Indian Standard

VITREOUS ENAMELWARE — METHODS OF TEST

PART 2 TEST METHODS

SECTION 12 RESISTANCE TO TORSION

(Second Revision)

1 SCOPE

This standard (Part 2/Sec 12) prescribes the method for resistance to torsion for vitreous enamelware.

2 REFERENCES

The standard given below contain provisions which, through reference in this text, constitute provisions of this standard. At the time of publication, the edition indicated was valid. All standard are subject to revisions, and parties to agreements based on this standard are encouraged to investigate the possibility of applying the most recent edition of these standard.

IS No.	Title
IS 2717 : 1979	Glossary of terms relating to vitreous enamelware and ceramic-metal systems (<i>first revision</i>)

3 TERMINOLOGY

For the purpose of this standard the definitions given in IS 2717 shall apply.

4 APPARATUS

The apparatus essentially consists of a grip assembly which keeps one end of the specimen stationary while the other end is rotated about a predetermined axis at the rate of 100° per min by means of a motor-driven grip assembly. The non-rotary grip

assembly rests in ball bushings which permit free linear motion as the specimen shortens during twisting.

5 TEST SPECIMEN**5.1 Test Specimens**

For each sample, prepare ten flat test blanks of enameling iron 302 mm × (50 ± 0.4) mm × (0.9 ± 0.025) mm (can be selected from 20 gauge). Variation of thickness between any two blanks shall not exceed 0.05 mm where the metal thickness is not a desired variable of the investigation.

5.1.1 Holes which are required in the test specimens shall be placed as in [Fig. 1](#) with the exercise of proper caution to ensure that the specimens are not deformed during the process.

5.1.2 All burrs developing from shearing, drilling or punching shall be removed before the specimens are formed.

5.2 Form flat test blanks into (90 ± 1)° angular specimens as measured within 15 mm of either end with an adjustable protractor.

5.2.1 The inside radius of bend shall be 3.0 mm as measured with commercial V-dies or bending bar, and the apex of the radius shall be located at the centre of the width so that when measured as shown in [Fig. 2](#), the width of sides does not differ by more than 0.8 mm.

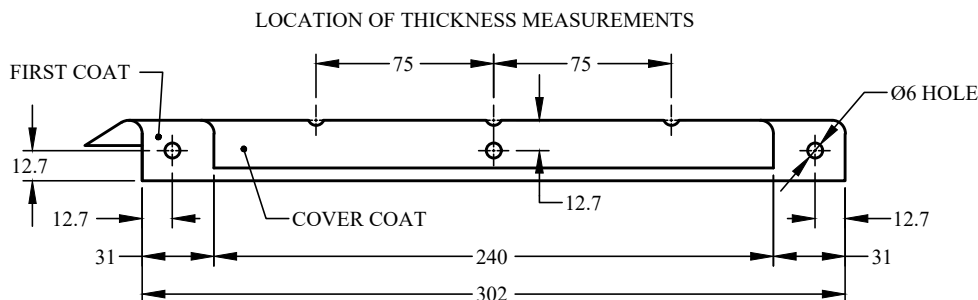

All dimensions in millimetres.

FIG. 1 DIAGRAM SHOWING STANDARD TORSION SPECIMEN

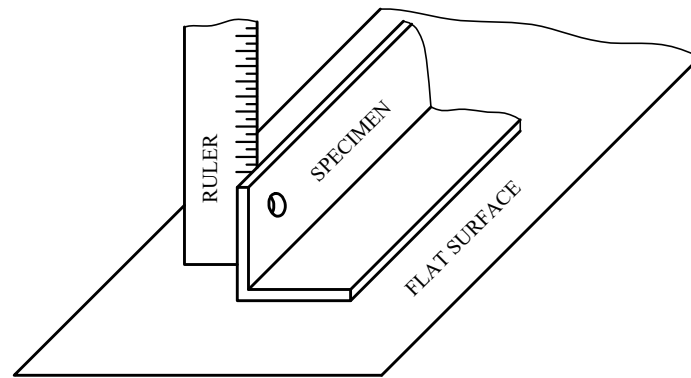

FIG. 2 SKETCH SHOWING METHOD OF MEASURING WIDTH OF FORMED SPECIMEN

5.3 Preparation of Test Specimens

5.3.1 The enamel thickness of the 'sides' shall be less by about 20 percent and never to exceed that on the apex. To avoid the difficulty of applying an even thickness over a convex surface and the adjacent flat areas, it may be necessary to spray an extra amount to enamel on the apex of the specimen to bring the thickness within the requirements.

5.3.2 The ground coating of enamel should be on all sides of the specimen. Any bead apparent in the first coat after drying should be removed before firing. There shall be no bead on the ends of the specimen where it will interfere with clamping.

5.3.3 Where a second or cover coat is to be evaluated, it is to be applied to the outside of the specimen only. After drying and before firing, the cover coating shall be brushed back 31 mm from each end and 6 mm from each side of the specimen as shown in [Fig. 1](#).

5.3.4 The tolerance limit of the total enamel thickness shall be ± 20 percent of the desired standard thickness with at least three of the specimens having a thickness less than the standard and at least three of the specimens having a thickness greater than standard, unless at least five specimens have exactly the standard thickness.

5.3.5 Measure the enamel thickness at three evenly spaced points on the apex and at one point on each side of the specimen 13 mm from the apex and midway between the ends (see [Fig. 1](#)). The enamel thickness shall be average of the three measurements made on the apex, and the thickness of the sides shall conform to the requirements as given in [5.3.1](#).

5.3.6 Measurements may be made by any nondestructive means or gauge that will give readings accurate to within 10 percent on areas

19 mm square and on a curved surface with a radius as small as 3 mm.

5.3.7 Subject a group of test specimens to identical cleaning and pickling procedures and preferably pickle together. This step is especially important for finish coat applied directly to the metal.

6 METHOD OF TEST

6.1 The rotary head of the torsion test machine will cruise about 2° after the motor switch has been turned off. This 'cruise constant' is determined as follows:

With the control lever on 'reset' rotate the free head by hand until the pointer indicator comes to the 350° mark. Raise control lever to 'run' and when the pointer indicates 358° , move the control lever to 'stop' and note the position where the pointer comes to rest.

6.2 Mount the test specimen in the machine with the non-rotary grip assembly, which has a free lateral motion, at the extreme position from the rotary head. Insert the end of the specimen into the open grip on the rotary head, and laterally move the non-rotary grip over the other end of the specimen. Position the non-rotary grip by pulling a cam-lock lever against a pin stop, which assures a distance of 250 mm between grip faces. Cam-lock levers are provided for locking the specimen firmly in each grip.

6.3 Use a cellulose sponge or a soft cloth and one percent solution of trisodium phosphate to wet the specimen uniformly before starting the test and maintain the surface visibly wet by quickly stroking the specimen at every 40° of twist required to produce failure.

6.4 Begin twisting by moving the control lever to 'run' and continue until a chip occurs along the apex

and within the central 229 mm of the specimen. Chips on apparent failure within 12.7 mm of the grips or on the edge of the sides should not be considered.

6.5 Immediately upon observing failure, move the control lever to 'stop' position. Compensate the degrees of twist to cause failure by subtracting the previously determined 'cruise constant' from the indicator reading after the motor has stopped.

7 CALCULATION

7.1 Calculations for Single Determination

7.1.1 The sample consists of ten specimens. Plot the results for the ten specimens with degrees torsion T versus enamel thickness t on cartesian (rectilinear) graph paper (see [Fig. 3](#) and [Table 1](#)).

7.1.2 Determine the average degrees torsion T_1 and T_2 and the average enamel thicknesses t_1 and t_2 for (a) the specimens having the five lowest values of T , and (b) the specimens having the five highest values of t . If more than one point occurs on the chart, at the value of t that divides the high and low groups, then assign them to the respective groups in such distribution that each group contains five specimens. For simplicity, this distribution is to be made according to values to T , the specimens with high value T of being placed with the group of low t , and vice versa.

7.1.3 Plot these two average points on the chart and draw a straight line through them. This is the line referred to in [7.1.4](#), [7.2](#) and [7.2.1](#).

7.1.4 Locate the value T on the ordinate that corresponds to the line to the appropriate standard enamel thickness (0.152 mm, 0.254 mm and 0.381 mm). This value of T is the torsion rating of the sample and will hereafter be known as ' T bar' or \bar{T} .

NOTE — In the example, shown in [Fig. 3](#), T is 89.5.

7.2 Determine the effective range R of the torsion value T as follows:

Locate the point farthest from the line (point 1) and graphically determine the vertical distance, d_1 , of this point from the line. Locate point 2, which is the one farthest from the line on the opposite side of the line from point 1. Graphically determine the vertical distance d_2 , of this point from the line, and determine R from the formula given below:

$$R = d_1 + d_2$$

7.2.1 Calculate the statistical error e (95 percent confidence) of T from the following formula, using the appropriate value of the coefficient α from [Table 2](#):

$$e = \alpha R$$

Since for ten specimens $\alpha = 0.23$, the expression becomes $e = 0.23 R$, in which $T \pm e$ gives the 95 percent confidence limits, and R is the effective range of ten torsion values.

7.2.2 In reporting the results, the gauge of the metal and the test thickness of the enamel shall be stated as well as the torsion rating of each sample and the statistical error e (95 percent confidence). The latter two values shall be reported to the nearest 0.1°.

7.2.3 The following example of the torsion calculations for an enamel of 0.254 mm thickness is defined by the data in [Table 1](#). The data in [Table 1](#) have been arranged in increasing order of enamel thickness to facilitate determination of the subgroup average. The data and averages have been plotted in [Fig. 3](#) from which the torsion rating is found to be 89.5°. Since $d_1 = 9.0$ and $d_2 = 8.2$, the effective range $R = 9.0 + 8.2 = 17.2$; the 95 percent confidence error $e = 0.23 \times 17.2 = 3.96$. The torsion rating is thus reported as follows:

$$\bar{T} = 89.5 \pm 4.0$$

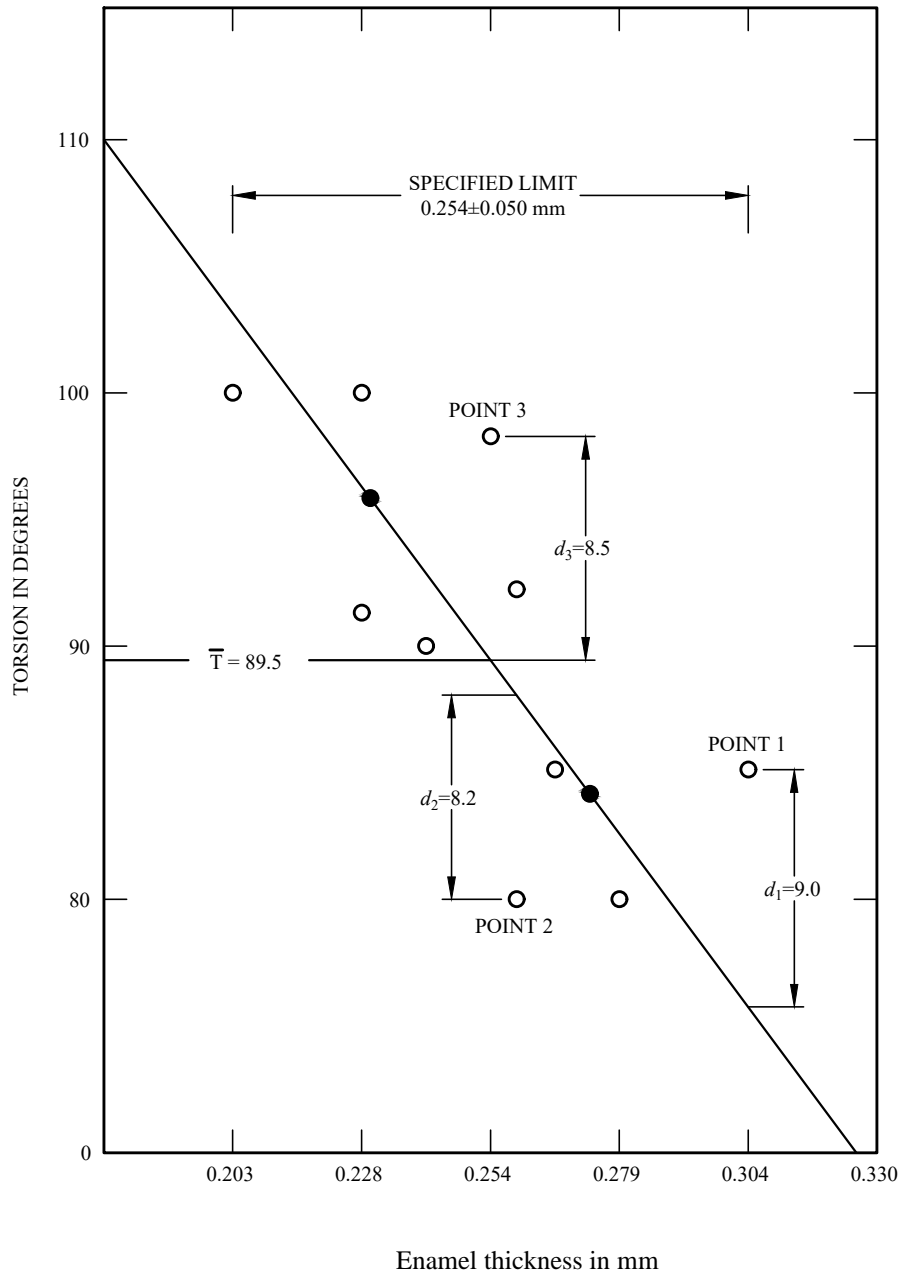

FIG. 3 PLOT OF TORSION DATA SHOWN IN [TABLE 1](#)

Table 1 Degrees Torsion for Enamels*(Clauses [7.1.1](#) and [7.2.3](#))*

SI No.	Specimen No.	Enamel Thickness t, mm	Sub-group Average	Degrees Torsion	Sub-group Average
(1)	(2)	(3)	(4)	(5)	(6)
i)	1	0.206	0.231	100	95.8
ii)	2	0.228		100	
iii)	3	0.228		91	
iv)	4	0.241		90	
v)	5	0.254		98	
vi)	6	0.259	0.273	92	84.4
vii)	7	0.259		80	
viii)	8	0.266		85	
ix)	9	0.279		80	
x)	10	0.304		85	

Table 2 Values of Coefficient α for 95 Percent Confidence Limits*(Clause [7.2.1](#))*

Sl No.	Number of Specimens	Coefficient α
(1)	(2)	(3)
i)	3	1.30
ii)	4	0.72
iii)	5	0.51
iv)	6	0.40
v)	7	0.33
vi)	8	0.29
vii)	9	0.25
viii)	10	0.23

ANNEX A

(Foreword)

COMMITTEE COMPOSITION

Ceramicware Sectional Committee, CHD 9

<i>Organization</i>	<i>Representative(s)</i>
CSIR - Central Glass and Ceramic Research Institute, Kolkata	DR SUMAN KUMARI MISHRA (<i>Chairperson</i>)
Aditya Birla Insulators Company, Halol	SHRI UTTAM SARKAR
Ahmedabad Pottery Manufacturers Association, Naroda	SHRI RUPESH C. SHAH
All India Institute of Hygiene and Public Health, Kolkata	PROF R. C. SRIVASTAVA DR NIBEDITA DAS (<i>Alternate</i>)
All India Pottery Manufacturers Association, Kolkata	SHRI SABYASACHI ROY SHRI SANDIP KUMAR (<i>Alternate</i>)
Ants Ceramics Private Limited, Thane	SHRI ASHWINI JAIN SHRI SHOBHIT MISHRA (<i>Alternate</i>)
Associated Soapstone Distributing Company Private Limited, Jaipur	SHRI DILIP JHA SHRI AMIT SHARMA (<i>Alternate</i>)
Bhabha Atomic Research Centre, Mumbai	DR. RAJA KISHORI LENKA
Bharat Heavy Electrical Limited, New Delhi	DR C. D. MADHUSOODANA SHRI G. THIRUPATHI (<i>Alternate</i>)
Clay Craft India Private Limited, Jaipur	SHRI BHARAT AGARWAL SHRI MASROOR USMANI (<i>Alternate</i>)
CSIR - Central Glass and Ceramic Research Institute, Kolkata	DR H. S. TRIPATHI DR SOMNATH SINHAMAHAPATRA (<i>Alternate</i>)
Directorate General of Quality Assurance, Ministry of Defence, New Delhi	SHRI BRIG D. B. S. KUSHWAHA SHRI D. K. MOHAPATRA (<i>Alternate</i>)
Government College of Engineering and Ceramic Technology, Kolkata	PROF. RITUPARNO SEN SHRI RAM CHANDRA DAS (<i>Alternate</i>)
H. R. Johnson (India) Limited, Dewas	SHRI SUDIPTA SAHA
Hindware Limited, Bahadurgarh	DR R. K. SOMANY SHRI T. K. RAHA (<i>Alternate</i>)
Indian Institute of Technology BHU, Varanasi	PROF VINAY KUMAR SINGH DR MANAS RANJAN MAJHI (<i>Alternate</i>)
Khurja Pottery Manufacturers Association, Khurja	SHRI DARSHAN CHHATWAL SHRI RAVI RANA (<i>Alternate</i>)
MSME Testing Center, New Delhi	SHRI AMBROSE ROYSON C. SHRI G. V. RANGARAO (<i>Alternate</i>)
National Institute of Technology, Rourkela	SHRI RANABRATA MAZUMDER SHRI PARTHA SAHA (<i>Alternate</i>)
National Test House, Kolkata	SHRI AJAY A. UKARANDE MS TRIPTI MONDAL (<i>Alternate</i>)

IS 3972 (Part 2/Sec 12) : 2024

<i>Organization</i>	<i>Representative(s)</i>
Porcelain Enameled Association, Kolkata	SHRI B. S. GANGULY DR SOMESWAR DATTA (<i>Alternate</i>)
Roca Bathroom Products Private Limited, Chennai	SHRI KANNAN CHELLAPPAN SHRI HRUSHIKESH R BHANDAKKAR (<i>Alternate</i>)
Saint-Gobain India Private Limited, Chennai	SHRI MANISH KUMAR
Somany Ceramics Limited, Bahadurgarh	SHRI ARINDAM CHAUDHURI SHRI RUDRA PRASAD MISHRA (<i>Alternate</i>)
In Personal Capacity (<i>BC-224, Sec-1, Salt Lake, Kolkata - 700064</i>)	SHRI K. K. PAUL
BIS Directorate General	SHRI A. K. LAL SCIENTIST 'F'/SENIOR DIRECTOR AND HEAD (CHEMICAL) [REPRESENTING DIRECTOR GENERAL, BIS (<i>Ex-officio</i>)]

Member Secretary
MS PUJA PRIYA
SCIENTIST 'D'/JOINT DIRECTOR
(CHEMICAL), BIS

Bureau of Indian Standards

BIS is a statutory institution established under the *Bureau of Indian Standards Act, 2016* to promote harmonious development of the activities of standardization, marking and quality certification of goods and attending to connected matters in the country.

Copyright

BIS has the copyright of all its publications. No part of these publications may be reproduced in any form without the prior permission in writing of BIS. This does not preclude the free use, in the course of implementing the standard, of necessary details, such as symbols and sizes, type or grade designations. Enquiries relating to copyright be addressed to the Head (Publication & Sales), BIS.

Review of Indian Standards

Amendments are issued to standards as the need arises on the basis of comments. Standards are also reviewed periodically; a standard along with amendments is reaffirmed when such review indicates that no changes are needed; if the review indicates that changes are needed, it is taken up for revision. Users of Indian Standards should ascertain that they are in possession of the latest amendments or edition by referring to the website-www.bis.gov.in or www.standardsbis.in.

This Indian Standard has been developed from Doc No.: CHD 09 (24974).

Amendments Issued Since Publication

Amend No.	Date of Issue	Text Affected

BUREAU OF INDIAN STANDARDS

Headquarters:

Manak Bhavan, 9 Bahadur Shah Zafar Marg, New Delhi 110002

Telephones: 2323 0131, 2323 3375, 2323 9402

Website: www.bis.gov.in

Regional Offices:

Central : 601/A, Konnectus Tower -1, 6th Floor,
DMRC Building, Bhavbhuti Marg, New
Delhi 110002

Telephones

{ 2323 7617

Eastern : 8th Floor, Plot No 7/7 & 7/8, CP Block, Sector V,
Salt Lake, Kolkata, West Bengal 700091

{ 2367 0012
2320 9474

Northern : Plot No. 4-A, Sector 27-B, Madhya Marg,
Chandigarh 160019

{ 265 9930

Southern : C.I.T. Campus, IV Cross Road, Taramani, Chennai 600113

{ 2254 1442
2254 1216

Western : Manakalya, 5th Floor/MTNL CETTM, Technology Street, Hiranandani Gardens, Powai
Mumbai 400076

{ 25700030
25702715

Branches : AHMEDABAD, BENGALURU, BHOPAL, BHUBANESHWAR, CHANDIGARH, CHENNAI, COIMBATORE, DEHRADUN, DELHI, FARIDABAD, GHAZIABAD, GUWAHATI, HARYANA (CHANDIGARH), HUBLI, HYDERABAD, JAIPUR, JAMMU, JAMSHEDPUR, KOCHI, KOLKATA, LUCKNOW, MADURAI, MUMBAI, NAGPUR, NOIDA, PARWANOO, PATNA, PUNE, RAIPUR, RAJKOT, SURAT, VIJAYAWADA.