

रेफ्रिजरेंट — विशिष्टि
(तीसरा पुनरीक्षण)

Refrigerants — Specification
(Third Revision)

ICS 71.100.45

© BIS 2024



भारतीय मानक ब्यूरो
BUREAU OF INDIAN STANDARDS
मानक भवन, 9 बहादुर शाह ज़फर मार्ग, नई दिल्ली - 110002
MANAK BHAVAN, 9 BAHADUR SHAH ZAFAR MARG
NEW DELHI - 110002

www.bis.gov.in www.standardsbis.in

December 2024

Price Group 13

FOREWORD

This Indian Standard (Third Revision) was adopted by the Bureau of Indian Standards, after the draft finalized by the Industrial Gases Sectional Committee had been approved by the Chemical Division Council.

This standard was first published in 1970. The standard was subsequently revised in 1983 and 1993. To define the quality of refrigerants used for refrigeration and air conditioning, as solvents and for aerosol making purposes, with a view to provide guidance to the manufacturer, seller, purchaser, and the end user, who may assure the supply of proper quality of these products.

In accordance with the Montreal Protocol, developing nations committed to initiating a decrease in the consumption and production of HCFCs by 2015, aiming for a complete 100 percent reduction by 2030. At least 4 out of the 6 gases that are CFCs (R-11, R-12, R-113, R-114) included in the standard have been phased out worldwide and have been banned in India under ODS Rules on account of being high ozone depleting substances (CFCs). Further gas R-21 cannot be produced any longer under the ODS Rules, and HCFC (R-22) will be phased out by 2030 due to high GWP as a GHG.

Currently HFCs have replaced HCFCs and are being used in India for refrigeration and air-conditioning. However, after India's ratification of the Kigali Agreement of the Montreal Protocol, even the HFCs have been placed under a gradual phase down starting from 2 028 to 2 040 to enable their eventual replacement by Zero ODP, low GWP refrigerants.

In light of this, the committee has chosen to revise the standard to align with best International Practices, encompassing various refrigerants in a unified standard.

In this revision of IS 5610 the title has been modified, alternative refrigerants in place of phased out refrigerants with specifications have been incorporated and modifications made in requirements of packing.

The designations of various types of refrigerants specified in this standard are based in the numbering system given in IS 16656 : 2017/ISO 817 : 2014. For the sake of clarity, the chemical formulae of the various types of the refrigerants including CAS number are also given.

The composition of the Committee responsible for formulation of this standard is given in [Annex D](#).

For the purpose of deciding whether a particular requirement of this standard is complied with, the final value, observed or calculated, expressing the result of a test or analysis, shall be rounded off in accordance with IS 2 : 2022 'Rules for rounding off numerical values (*second revision*)'. The number of significant places retained in the rounded off value should be the same as that of the specified value in this standard.

Indian Standard
REFRIGERANTS — SPECIFICATION
(Third Revision)

1 SCOPE

1.1 This standard prescribes requirements and methods of sampling and test for refrigerants for refrigeration and air conditioning purposes and for use as solvents and for making aerosol.

1.2 This standard is not applicable to refrigerants meant for pharmaceutical and fire extinguisher applications.

2 REFERENCE

The standards listed in [Annex A](#) contain provisions which through reference in the text, constitute provisions of and necessary adjuncts to this standard. At the time of publication, the editions indicated were valid. All standards are subject to revision and parties to agreements based on this standard are encouraged to investigate the possibility of applying the most recent edition of these standards.

3 TERMINOLOGY

For the purpose of this standard, the definitions given in IS 7062 shall apply, in addition to the following:

3.1 Boiling Point — Temperature at which the vapor pressure of a liquid equals the absolute external pressure at the liquid vapor interface.

3.2 Boiling Range — Boiling range refers to the temperature range of a laboratory distillation (difference in temperature recorded) of a refrigerant from 5 percent to 85 percent evaporation is complete.

3.3 Bubble Point — The liquid saturation temperature of a refrigerant at the specified pressure; the temperature at which a liquid refrigerant first begins to boil. The bubble point of a zeotropic refrigerant blend, at constant pressure, is lower than the dew point.

3.4 Bubble-Point Temperature — A liquid-vapor equilibrium points for a volatile pure liquid or for a multicomponent mixture of miscible, volatile, pure component liquids, in the absence of non-condensable, where the temperature of the mixture at a defined pressure is the minimum temperature required for a vapor bubble to form in the liquid.

3.5 Critical Temperature — The critical temperature of a refrigerant is the temperature at

which the refrigerant can no longer back from vapor state to liquid state regardless of the pressure.

3.6 Dew-point Temperature — Temperature of moist air saturated at pressure p , with the same humidity ratio was that of the given sample of moist air. It is defined as the solution $t_d(p, W)$ of the equation: $W_s(p, t_d) = W$.

3.7 Recycled Refrigerant — Recycled refrigerant is a material that has been recovered during production process but not meeting the specifications. It is finally processed into finished product to meet the prescribed specifications. Reclaimed refrigerants are not considered as recycled refrigerants.

3.8 Virgin Refrigerant — Refrigerant that has not been subjected to use or processing other than that required for its original manufacture.

4 TYPES

The refrigerants extensively used in various industries covered under this standard are given in [Table 1](#).

5 REQUIREMENTS

5.1 The refrigerants covered under this standard shall comply with requirements given in relevant tables as given in [5.2](#) when tested according to the methods prescribed in [Annex B](#), except for the requirements given for information purpose only.

5.2 Requirements for Refrigerants

- a) Fluorocarbon Refrigerants shall comply with the requirements given in [Table 2](#);
- b) Refrigerants blend 400 and 500 series shall comply with the requirements given in [Table 3](#) and [Table 4](#);
- c) Hydrofluoroolefin (HFO) refrigerants shall comply with the requirements given in [Table 5](#); and
- d) Hydrocarbon refrigerants shall comply with the requirements given in [Table 6](#).

5.3 When the refrigerants cylinder returns with a residual gas content for refilling, it shall not be drained in an open atmosphere, instead the material shall be taken to the plant system for reprocessing.

Table 1 Types of Refrigerants

(Clause 4)

SI No.	Type	Chemical Name	Formula	CAS Number
(1)	(2)	(3)	(4)	(5)
(i)	R-22	Chlorodifluoromethane	CHClF ₂	75-45-6
(ii)	R-134a	1, 1, 1, 2-Tetrafluoroethane	C ₂ H ₂ F ₄	811-97-2
(iii)	R-32	Difluoromethane	CF ₂ H ₂	75-10-5
(iv)	R-245fa	1,1,1,3,3-Pentafluoropropane	C ₃ H ₃ F ₅	460-73-1
(v)	R-125	1,1,1,2,2-Pentafluoroethane	C ₂ HF ₅	354-33-6
(vi)	R-152a	1,1-Difluoroethane	C ₂ H ₄ F ₂	75-37-6
(vii)	R-410A	Difluoromethane, 1,1,1,2,2-Pentafluoroethane	CH ₂ F ₂ , CHF ₂ CF ₃	75-10-5, 354-33-6
(viii)	R-404A	1,1,1,2,2-Pentafluoroethane, 1,1,1-Trifluoroethane, 1,1,1,2-Tetrafluoroethane	C ₂ HF ₅ , C ₂ H ₃ F ₃ , CF ₃ CH ₂ F	354-33-6-0, 420-46-2, 811-97-2
(ix)	R-407C	1,1,1,2-Tetrafluoroethane, Difluoromethane, 1,1,1,2,2-Pentafluoroethane	CF ₃ CH ₂ F, CH ₂ F ₂ , CHF ₂ CF ₃	811-97-2, 75-10-5, 354-33-6
(x)	R-407A	1,1,1,2-Tetrafluoroethane, Difluoromethane, 1,1,1,2,2-Pentafluoroethane	CF ₃ CH ₂ F, CH ₂ F ₂ , CHF ₂ CF ₃	811-97-2, 75-10-5, 354-33-6
(xi)	R-426A	1,1,1,2,2-Pentafluoroethane, 1,1,1,2-Tetrafluoroethane, Isobutane, Isopentane	CHF ₂ CF ₃ , CF ₃ CH ₂ F, C ₄ H ₁₀ , C ₅ H ₁₂	354-33-6-0, 811-97-2, 75-28-5, 78-78-4
(xii)	R-438A	Difluoromethane, 1,1,1,2,2-Pentafluoroethane, 1,1,1,2-Tetrafluoroethane, Isobutane, Isopentane	CF ₂ H ₂ , CHF ₂ CF ₃ , CF ₃ CH ₂ F, C ₄ H ₁₀ , C ₅ H ₁₂	75-10-5, 354-33-6, 811-97-2, 75-28-5, 78-78-4
(xiii)	R-448A	Difluoromethane, 1,1,1,2,2-Pentafluoroethane, 2,3,3,3-Tetrafluoropropene, 1,1,1,2-Tetrafluoroethane, trans-1,3,3,3-Tetrafluoropropene	CF ₂ H ₂ , CHF ₂ CF ₃ , C ₃ H ₂ F ₄ , C ₂ H ₂ F ₄ , C ₃ H ₂ F ₄	75-10-5, 354-33-6, 754-12-1, 811-97-2, 29118-24-9
(xiv)	R-449A	Difluoromethane, 1,1,1,2,2-Pentafluoroethane, 2,3,3,3-Tetrafluoropropene, 1,1,1,2-Tetrafluoroethane	CF ₂ H ₂ , CHF ₂ CF ₃ , C ₃ H ₂ F ₄ , C ₂ H ₂ F ₄	75-10-5, 354-33-6, 754-12-1, 811-97-2
(xv)	R-449C	Difluoromethane, 1,1,1,2,2-Pentafluoroethane, 2,3,3,3-Tetrafluoropropene, 1,1,1,2-Tetrafluoroethane	CF ₂ H ₂ , CHF ₂ CF ₃ , C ₃ H ₂ F ₄ , C ₂ H ₂ F ₄	75-10-5, 354-33-6, 754-12-1, 811-97-2
(xvi)	R-407F	Difluoromethane, 1,1,1,2,2-Pentafluoroethane, 1,1,1,2-Tetrafluoroethane	CF ₂ H ₂ , CHF ₂ CF ₃ , C ₂ H ₂ F ₄	75-10-5, 354-33-6, 811-97-2
(xvii)	R-452A	Difluoromethane, 1,1,1,2,2-Pentafluoroethane, 2,3,3,3-Tetrafluoropropene	CF ₂ H ₂ , CHF ₂ CF ₃ , C ₃ H ₂ F ₄	75-10-5, 354-33-6, 754-12-1

SI No.	Type	Chemical Name	Formula	CAS Number
(1)	(2)	(3)	(4)	(5)
(xviii)	R-454B	Difluoromethane, 2,3,3,3-Tetrafluoropropene	CF ₂ H ₂ , C ₃ H ₂ F ₄ ,	75-10-5, 754-12-1
(xix)	R-454C	Difluoromethane, 2,3,3,3-Tetrafluoropropene	CF ₂ H ₂ , C ₃ H ₂ F ₄ ,	75-10-5, 754-12-1
(xx)	R-507A	1,1,1,2,2-Pentafluoroethane, 1,1,1-Trifluoroethane	CHF ₂ CF ₃ , C ₂ H ₃ F ₃	354-33-6, 420-46-2
(xxi)	HFC-23	Trifluoromethane	CHF ₃	75-46-7
(xxii)	R-508B	Trifluoromethane, Hexafluoroethane	CHF ₃ , C ₂ F ₆	75-46-7, 76-16-4
(xxiii)	R-513A	2,3,3,3-Tetrafluoropropene, 1,1,1,2-Tetrafluoroethane	C ₃ H ₂ F ₄ , C ₂ H ₂ F ₄	754-12-1, 811-97-2
(xxiv)	R-514A	(Z)-1,1,1,4,4,4-hexafluorobutene, (E)-1,2-dichloroethene	C ₄ H ₂ F ₆ , C ₂ H ₂ Cl ₂	692-49-9, 156-60-5
(xxv)	R-290	Propane	C ₃ H ₈	74-98-6
(xxvi)	R-600a	Isobutane	C ₄ H ₁₀	75-28-5
(xxvii)	HFO-1234YF	2,3,3,3-Tetrafluoropropene	C ₃ H ₂ F ₄	754-12-1
(xxviii)	HFO-1234ZE	1,3,3,3-Tetrafluoropropene	C ₃ H ₂ F ₄	1645-83-6
(xxix)	R-467A	Pentafluoro ethane (R-125), 1,1,1,2-Tetrafluoroethane (R-134a), Difluoromethane (R-32), Iso Butane (R-600a)	CHF ₂ CF ₃ , C ₂ H ₂ F ₄ , CF ₂ H ₂ , C ₄ H ₁₀	354-33-6, 811-97-2, 75-10-5, 75-28-5
(xxx)	R-422B	1,1,1,2-Tetrafluoroethane (R-134a), 1,1,1,2,2-Pentafluoroethane, Iso Butane (R-600a)	CF ₃ CH ₂ F, CHF ₂ CF ₃ , C ₄ H ₁₀	811-97-2, 354-33-6, 75-28-5
(xxxii)	HFO-1233zd(E)	Trans-1-chloro-3,3,3-trifluoropropene	(E)CF ₃ -CH=CClH	102687-65-0
(xxxii)	Refrigerant Grade Ammonia — conforming to the requirements of Grade 1 ammonia as specified in IS 662.			

Table 2 Requirements for Fluorocarbon Refrigerants

(Clause 5.2)

SI No.	Characteristic	Requirement								Method of Test, Ref to
		R-22 Technical	R-22 Pure	R-134a	R-32	R-245fa	R-125	R-152a	HFC-23	
(1)	(2)	(3)	(4)	(5)	(6)	(7)	(8)	(9)	(10)	(12)
(i)	Moisture, ppm, w/w, <i>Max</i>	10	10	10	10	20	10	10	10	B-3
(ii)	Non-absorbable gases in vapor phase, percent v/v, <i>Max</i>	1.5	0.5	1.5	1.5	-	1.5	1.5	1.5	B-4
(iii)	*Initial boiling point, °C, <i>Max</i>	-40.8	- 40.8	- 26.1	- 51.7	14.9	- 48.1	-24	- 82	B-5
(iv)	*Boiling range from 5 percent to 85 percent evaporation, °C, <i>Max</i>	± 0.3	± 0.3	± 0.3	± 0.3	± 0.3	± 0.3	± 0.3	± 0.5	B-5
(v)	Acidity, as hydrochloric acid (HCl), ppm, w/w, <i>Max</i>	1	0.1	1	1	1	1	1	1	B-6
(vi)	High Boiling Residue, %, w/w, <i>Max</i>	0.0020	0.001 0	0.002 0	0.010 0	0.010 0	0.0100	0.0100	0.010 0	B-7
(vii)	Appearance	Colourless	Clear and Colour less	Colour less	Colour less	Colourless	Colour less	Colourless	Colour less	B-8
(viii)	Particulates/Solids	Visually Clean	Visually Clean	Visually Clean	Visually Clean	Visually Clean	Visually Clean	Visually Clean	Visually clean	B-8
(ix)	Chloride, no visible turbidity (indicates about 3 ppm)	No visible turbidity	No visible turbidity	No visible turbidity	No visible turbidity	No visible turbidity	No visible turbidity	No visible turbidity	No visible turbidity	B-9

SI No.	Characteristic	Requirement								Method of Test, Ref to
		R-22 Technical	R-22 Pure	R-134a	R-32	R-245fa	R-125	R-152a	HFC-23	
(x)	Purity, %, w/w, <i>Min</i>	99.90 (B-11)	99.98 (B-11)	99.90 (R-134a + R134) (B-11)	99.95 (B-11)	99.50 (B-11)	99.50 (B-10)	99.9 (B-10)	99.50 (B-10)	B-10 and B-11
(xi)	All other volatile impurities, %, w/w, <i>Max</i>	0.05 (B-11)	0.02 (B-11)	0.1 (B-11)	0.05 (B-11)	0.5 (B-11)	0.5 (B-10)	0.1 (B-10)	0.5 (B-10)	B-10 and B-11
(xii)	Halogenated unsaturated volatile impurities, %, w/w, <i>Max</i>	0.004 (B-11)	-	0.004 (B-11)	-	0.004 (B-11)	0.004 (B-10)	0.004 (B-10)	-	B-10 and B-11
(xiii)	R-40, %, w/w, <i>Max</i>	0.001 (B-11)	0.0005 (B-11)	0.005 (B-11)	-	-	-	-	-	B-11
(xiv)	CFC-12, %, w/w, <i>Max</i>	0.05 (B-11)	0.005 (B-11)	-	-	-	-	-	-	B-11
(xv)	HCFC-21, %, w/w, <i>Max</i>	0.001 (B-11)	0.0004 (B-11)	-	0.005 (B-11)	-	-	-	-	B-11
(xvi)	HFC-23, %, w/w, <i>Max</i>	-	0.0004 (B-11)	-	-	-	-	-	-	B-11
(xvii)	1-Chloro-1,1,2,2,2-Pentafluoroethane (R115), % w/w, <i>Max</i>	-	0.0005 (B-11)	-	-	-	0.02 (B-10)	-	-	B-10 and B-11
(xviii)	HCFC-31, %, w/w, <i>Max</i>	0.01 (B-11)	0.0005 (B-11)	-	0.0003 (B-11)	-	-	-	-	B-11
(xix)	HFC-32, %, w/w, <i>Max</i>	0.01 (B-11)	0.0015 (B-11)	-	-	-	-	-	-	B-11

SI No.	Characteristic	Requirement								Method of Test, Ref to
		R-22 Technical	R-22 Pure	R-134a	R-32	R-245fa	R-125	R-152a	HFC-23	
(xx)	HFC-134a, %, w/w, <i>Max</i>	-	0.001 (B-11)	-	-	-	-	-	-	B-11
(xxi)	Isomer HFC-134, %, w/w, <i>Max</i>	-	-	0.2 (B-11)	-	-	-	-	-	B-11
(xxii)	Total CFCs, %, w/w, <i>Max</i>	-	-	-	0.04 (B-11)	-	-	-	-	B-11
(xxiii)	Total HCFCs, %, w/w, <i>Max</i>	-	-	-	0.04 (B-11)	-	-	-	-	B-11
(xxiv)	Total Unsaturated Compounds, %, w/w, <i>Max</i>	-	-	-	0.004 (B-11)	-	-	-	-	B-11
(xxv)	Total Fluorinated Unsaturated Compounds, %, w/w, <i>Max</i>	-	-	-	0.002 (B-11)	-	-	-	-	B-11
(xxvi)	Sum HCC-30 (MDC) + HCC-40 (Methyl Chloride), %, w/w, <i>Max</i>	-	-	-	0.003 (B-11)	-	-	-	-	B-11
(xxvii)	HCFC-133a, %, w/w, <i>Max</i>	-	-	-	0.005 (B-11)	-	-	-	-	B-11
(xxviii)	1-Chloro-1,2,2,2-Tetrafluoroethane (R124), %, w/w, <i>Max</i>	-	-	-	-	-	0.02 (B-10)	-	-	B-10
(xxix)	Isomer ea R-245ca, R-245cb, R-245ea, R-245eb, %, w/w, <i>Max</i>	-	-	-	-	0.1 (B-11)	-	-	-	B-11

SI No.	Characteristic	Requirement								Method of Test, Ref to
		R-22 Technical	R-22 Pure	R-134a	R-32	R-245fa	R-125	R-152a	HFC-23	
(xxx)	Odor	-	No Strange Odour	Slight Ether/ No Malodor	Slight Ether/ No Malodor	-	-	-	-	B-8
(xxxi)	*Critical Temperature, °C	96.2	96.2	101.1	78.1	154.1	66	113.3	26.1	For information purpose

Table 3 Requirements for Refrigerants Blend 400 and 500 Series

(Clause [5.2](#))

SI No.	Characteristic	R-410A	R-404A	R-407C	R-426A	R-438A	R-448A	R-449A	R-449C	R-407F	R-452A	R-454B	R-454C	R-507A	R-508B	R-513A	R-514A	R-467A	Method of Test, Ref to
(1)	(2)	(3)	(4)	(5)	(6)	(7)	(8)	(9)	(10)	(11)	(12)	(13)	(14)	(15)	(16)	(17)	(18)	(19)	(20)
(i)	Moisture, ppm, w/w, <i>Max</i>	10	10	10	10	10	10	10	10	10	10	10	10	10	10	10	20	10	B-3
(ii)	Non-absorbable gases in vapor phase, percent v/v, <i>Max</i>	1.5	1.5	1.5	1.5	1.5	1.5	1.5	1.5	1.5	1.5	1.5	1.5	1.5	1.5	1.5	-	1.5	B-4
(iii)	Acidity, as Hydrochloric Acid (HCl), ppm, w/w, <i>Max</i>	1	1	1	1	1	1	1	1	1	1	1	1	1	1	1	1	1	B-6

IS 5610 : 2024

Sl No.	Characteristic	R-410A	R-404A	R-407C	R-426A	R-438A	R-448A	R-449A	R-449C	R-407F	R-452A	R-454B	R-454C	R-507A	R-508B	R-513A	R-514A	R-467A	Method of Test, Ref to	
(1)	(2)	(3)	(4)	(5)	(6)	(7)	(8)	(9)	(10)	(11)	(12)	(13)	(14)	(15)	(16)	(17)	(18)	(19)	(20)	
(iv)	High Boiling Residue, %, w/w, <i>Max</i>	0.0015	0.0020	0.0020	0.01	0.01	0.01	0.01	0.01	0.01	0.01	0.01	0.01	0.01	0.01	0.01	0.01	0.01	0.002	B-7
(v)	Appearance	Colourless	Colourless	Colourless	Colourless	Colourless	Colourless	Colourless	Colourless	Colourless	Colourless	Colourless	Colourless	Colourless	Colourless	Colourless	Colourless	Colourless	Colourless	B-8
(vi)	Particulates / Solids	Visually Clean	Visually Clean	Visually Clean	Visually clean	Visually clean	Visually clean	Visually clean	Visually clean	Visually clean	Visually clean	Visually clean	Visually clean	Visually clean	Visually clean	Visually clean	Visually clean	Visually clean	Visually clean	B-8
(vii)	Chloride, no visible turbidity (indicates about 3 ppm)	No visible turbidity	No visible turbidity	No visible turbidity	No visible turbidity	No visible turbidity	No visible turbidity	No visible turbidity	No visible turbidity	No visible turbidity	No visible turbidity	No visible turbidity	No visible turbidity	No visible turbidity	No visible turbidity	No visible turbidity	No visible turbidity	No visible turbidity	No visible turbidity	B-9
(viii)	Purity, %, w/w, <i>Min</i>	99.9 (B-12)	99.9 (B-12)	99.9 (B-12)	99.5 (B-12)	99.5 (B-12)	99.5 (B-12)	99.5 (B-12)	99.5 (B-12)	99.5 (B-12)	99.5 (B-12)	99.5 (B-12)	99.5 (B-12)	99.5 (B-12)	99.5 (B-12)	99.5 (B-12)	99.5 (B-12)	99.5 (B-12)	99.9 (B-12)	B-12
(ix)	All other volatile impurities, %, w/w, <i>Max</i>	0.1 (B-12)	0.1 (B-12)	0.1 (B-12)	0.5 (B-12)	0.5 (B-12)	0.5 (B-12)	0.5 (B-12)	0.5 (B-12)	0.5 (B-12)	0.5 (B-12)	0.5 (B-12)	0.5 (B-12)	0.5 (B-12)	0.5 (B-12)	0.5 (B-12)	0.5 (B-12)	0.5 (B-12)	0.1 (B-12)	B-12

Sl No.	Characteristic	R-410A	R-404A	R-407C	R-426A	R-438A	R-448A	R-449A	R-449C	R-407F	R-452A	R-454B	R-454C	R-507A	R-508B	R-513A	R-514A	R-467A	Method of Test, Ref to
(1)	(2)	(3)	(4)	(5)	(6)	(7)	(8)	(9)	(10)	(11)	(12)	(13)	(14)	(15)	(16)	(17)	(18)	(19)	(20)
(x)	HFC-23, %, w/w, <i>Max</i>	-	-	-	-	-	-	-	-	-	-	-	-	-	44.0-48.0 (B-12)	-	-	-	B-12
(xi)	1-Chloro-1,1,2,2,2-Pentafluoroethane (R115), % w/w, <i>Max</i>	0.02 (B-12)	-	-	-	-	-	-	-	-	-	-	-	-	-	-	-	-	B-12
(xii)	HFC-32, %, w/w, <i>Max</i>	48.5-50.5 (B-12)	-	21.0-25.0 (B-12)	-	7.0-9.0 (B-12)	24.0-26.5 (B-12)	23.3-24.5 (B-12)	18.5-20.5 (B-12)	28.0-32.0 (B-12)	9.3-12.7 (B-12)	67.9-69.9 (B-12)	19.5-23.5 (B-12)	-	-	-	-	21.5-22.1 (B-12)	B-12
(xiii)	HFC-134a, %, w/w, <i>Max</i>	-	2.0-6.0 (B-12)	50.0-54.0 (B-12)	92.0-94.0 (B-12)	42.7-45.7 (B-12)	20.0-23.0 (B-12)	25.5-26.7 (B-12)	28.5-30.5 (B-12)	38.0-42.0 (B-12)	-	-	-	-	-	43.0-45.0 (B-12)	-	70.9-72.9 (B-12)	B-12
(xiv)	1-Chloro-1,2,2,2-Tetrafluoroethane (R124), %, w/w, <i>Max</i>	0.02 (B-12)	-	-	-	-	-	-	-	-	-	-	-	-	-	-	-	-	B-12
(xv)	1,1,1,2,2-Pentafluoroethane (R125), %, w/w, <i>Max</i>	49.5-51.5 (B-12)	42.0-46.0 (B-12)	23.0-27.0 (B-12)	4.1-6.1 (B-12)	43.5-46.5 (B-12)	25.5-28.0 (B-12)	24.5-25.7 (B-12)	19.5-21.5 (B-12)	28.0-32.0 (B-12)	57.2-60.8 (B-12)	-	-	49.5-51.5 (B-12)	-	-	-	4.5-5.5 (B-12)	B-12

IS 5610 : 2024

Sl No.	Characteristic	R-410A	R-404A	R-407C	R-426A	R-438A	R-448A	R-449A	R-449C	R-407F	R-452A	R-454B	R-454C	R-507A	R-508B	R-513A	R-514A	R-467A	Method of Test, Ref to
(1)	(2)	(3)	(4)	(5)	(6)	(7)	(8)	(9)	(10)	(11)	(12)	(13)	(14)	(15)	(16)	(17)	(18)	(19)	(20)
(xvi)	1,1,1-Trifluoroethane (HFC-143a), % w/w, <i>Max</i>	-	51.0-53.0 (B-12)	-	-	-	-	-	-	-	-	-	-	48.5-50.5 (B-12)	-	-	-	-	B-12
(xvii)	Odor	Etheral/sweet smell	-	-	-	-	-	-	-	-	-	-	-	-	-	-	-	-	B-8
(xviii)	*Bubble point, °C @ 101.3 kPa	-51.4	-46.2	-43.6	-28.5	-43	-45.9	-46	-44.6	-46.1	-47	-50.9	-46	-46.7	-87	-29.2	29	-	For information purpose
(xix)	*Dew Point, °C @ 101.3 kPa	-51.4	-45.5	-36.6	-26.7	-36.4	-39.8	-39.9	-38.1	-39.7	-43.2	-50	-37.8	-46.7	-87	-29.1	29	-	For information purpose
(xx)	*Critical Temperature, °C	71.4	72.1	86	100.2	84.2	81.6	81.5	83.5	83	74.9	76.5	82.4	70.6	11.8	96.5	178.1	91.96	For information purpose
(xxi)	R-600a, %, w/w	-	-	-	1.1-1.4 (B-12)	1.5-1.8 (B-12)	-	-	-	-	-	-	-	-	-	-	-	0.5-0.7 (B-12)	B-12

Sl No.	Characteristic	R-410A	R-404A	R-407C	R-426A	R-438A	R-448A	R-449A	R-449C	R-407F	R-452A	R-454B	R-454C	R-507A	R-508B	R-513A	R-514A	R-467A	Method of Test, Ref to
(1)	(2)	(3)	(4)	(5)	(6)	(7)	(8)	(9)	(10)	(11)	(12)	(13)	(14)	(15)	(16)	(17)	(18)	(19)	(20)
(xxii)	R-601a, %, w/w	-	-	-	0.4-0.7 (B-12)	0.4-0.7 (B-12)	-	-	-	-	-	-	-	-	-	-	-	-	B-12
(xxiii)	R-1234yf, %, w/w	-	-	-	-	-	18.0-20.5 (B-12)	24.3-25.5 (B-12)	29.5-31.5 (B-12)	-	29.0-30.1 (B-12)	30.1-32.1 (B-12)	76.5-80.5 (B-12)	-	-	55.0-57.0 (B-12)	-	-	B-12
(xxiv)	R-1234ze(E), %, w/w	-	-	-	-	-	5.0-7.5 (B-12)	-	-	-	-	-	-	-	-	-	-	-	B-12
(xxv)	R-116, %, w/w	-	-	-	-	-	-	-	-	-	-	-	-	-	52.0-56.0 (B-12)	-	-	-	B-12
(xxvi)	R-1336mzz(Z), %, w/w	-	-	-	-	-	-	-	-	-	-	-	-	-	-	-	74.2-76.2 (B-12)	-	B-12
(xxvii)	R-1130(E), %, w/w	-	-	-	-	-	-	-	-	-	-	-	-	-	-	-	23.8-25.8 (B-12)	-	B-12

IS 5610 : 2024

Sl No.	Characteristic	R-410A	R-404A	R-407C	R-426A	R-438A	R-448A	R-449A	R-449C	R-407F	R-452A	R-454B	R-454C	R-507A	R-508B	R-513A	R-514A	R-467A	Method of Test, Ref to
(1)	(2)	(3)	(4)	(5)	(6)	(7)	(8)	(9)	(10)	(11)	(12)	(13)	(14)	(15)	(16)	(17)	(18)	(19)	(20)

* Bubble points, dew points and critical temperatures are provided for informational purposes. Recognized chloride level for pass/fail is about 3 ppm. In R-290 and R-600a: 2 percent of other C3 and C4 saturated hydrocarbons are allowed.

Table 4 Requirements for Refrigerants Blend 400 and 500 Series*(Clause 5.2)*

Sl No.	Characteristic	R-407A	R-422B	Method of Test, Ref to
(1)	(2)	(3)	(4)	(5)
(i)	Moisture, ppm, w/w, <i>Max</i>	10	10	B-3
(ii)	Non-absorbable gases in vapour phase, percent v/v, <i>Max</i>	1.5	1.5	B-4
(iii)	Acidity, as hydrochloric acid (HCl), ppm, w/w, <i>Max</i>	1	1	B-6
(iv)	High boiling residue, percent, w/w, <i>Max</i>	0.010 0	0.002 0	B-7
(v)	Appearance	Colourless	Colourless	B-8
(vi)	Particulates/solids	Visually Clean	Visually clean	B-8
(vii)	Chloride, no visible turbidity (indicates about 3 ppm)	No visible turbidity	No visible turbidity	B-9
(viii)	Purity, percent, w/w, Minimum	99.90 (B-12)	99.90 (B-12)	B-12
(ix)	All other volatile impurities, percent, w/w, <i>Max</i>	0.50 (B-12)	0.10 (B-12)	B-12
(x)	HFC-32, percent, w/w, <i>Max</i>	18.0-22.0 (B-12)	-	B-12
(xi)	HFC-134a, percent, w/w, <i>Max</i>	38.0 to 42.0 (B-12)	41.0 to 43.0 (B-12)	B-12
(xii)	1,1,1,2,2-Pentafluoroethane (R125), percent, w/w, <i>Max</i>	38.0 to 42.0 (B-12)	54.0 to 56.0 (B-12)	B-12
(xiii)	*Bubble point, °C @ 101.3 kPa	-	- 40.5	For information purpose
(xiv)	*Dew Point, °C @ 101.3 kPa	-	- 35.6	For information purpose
(xv)	R-600a, w/w	-	2.5 to 3.1 (B-12)	B-12

* Bubble points, dew points, and critical temperatures are provided for informational purposes. The recognized chloride level for pass/fail is about 3 ppm. In R-290 and R-600a: 2 percent of other C3 and C4 saturated hydrocarbons are allowed.

Table 5 Requirements for Hydrofluoroolefin (HFO) Refrigerants*(Clause 5.2)*

Sl No.	Characteristic	HFO-1234YF	HFO-1234ZE	HFO-1233zd(E)	Method of Test, Ref to
(1)	(2)	(3)	(4)	(5)	(6)
(i)	Moisture, ppm, w/w, <i>Max</i>	10	10	20	B-3
(ii)	Non-absorbable gases in vapor phase, percent v/v, <i>Max</i>	1.5	1.5	Not Applicable	B-4
(iii)	*Initial boiling point, °C, <i>Max</i>	- 29.4	- 19	18.3	B-5
(iv)	Acidity, as Hydrochloric Acid (HCl), ppm, w/w, <i>Max</i>	1	1	1	B-6
(v)	High boiling residue, percent, w/w, <i>Max</i>	0.0100	0.0100	0.01	B-7
(vi)	Appearance	Colourless	Colourless	Colourless	B-8
(vii)	Particulates/Solids	Visually clean	Visually clean	Visually clean	B-8
(viii)	Chloride, no visible turbidity (indicates about 3 ppm)	No visible turbidity	No visible turbidity	No visible turbidity	B-9
(ix)	Purity, percent, w/w, <i>Min</i>	99.5 (B-11)	99.5 (B-11)	99.5	B-11
(x)	All other volatile impurities, %, w/w, <i>Max</i>	0.5 (B-11)	0.5 (B-11)	0.5	B-11
(xi)	*Critical Temperature, °C	94.8	109.4	(A-11)	For information purpose

* Boiling Points and critical temperatures are provided for informational purposes. Recognized chloride level for pass/fail is about 3 ppm. In R-290 and R-600a: 2 percent of other C3 and C4 saturated hydrocarbons are allowed.

Table 6 Requirements for Hydrocarbon Refrigerants*(Clause 5.2)*

Sl No.	Characteristic	R-290	R-600a	Method of Test, Ref to
(1)	(2)	(3)	(4)	(5)
i)	Moisture, ppm, w/w, <i>Max</i>	10	10	B-3
ii)	Non-absorbable gases in vapor phase, percent v/v, <i>Max</i>	1.5	1.5	B-4
iii)	*Initial boiling point, °C, <i>Max</i>	-42.1	-11.8	B-5
iv)	*Boiling ranges from 5 percent to 85 percent evaporation, °C, <i>Max</i>	±0.5	±0.5	B-5
v)	Acidity, as Hydrochloric Acid (HCl), ppm, w/w, <i>Max</i>	1	1	B-6
vi)	High Boiling Residue, percent, w/w, <i>Max</i>	0.0100	0.0100	B-7
vii)	Appearance	Colourless	Colourless	B-8
viii)	Particulates/Solids	Visually clean	Visually clean	B-8
ix)	Chloride, no visible turbidity (indicates about 3 ppm)	No visible turbidity	No visible turbidity	B-9
x)	Purity, percent, w/w, <i>Min</i>	99.5 (B-10)	99.5 (B-10)	B-10
xi)	All other volatile impurities, %, w/w, <i>Max</i>	0.5 (B-10)	0.5 (B-10)	B-10
xii)	Other Allowable Impurities, %, w/w, <i>Max</i>	2	2	B-10
xiii)	Sulphur Odor	No sulfur odor	No sulfur odor	B-8
xiv)	Total C3, C4, and C5 Polyolefins, percent, w/w, <i>Max</i>	0.05	0.05	B-10
xv)	N ₂ and O ₂ , percent, v/v, <i>Max</i>	-	0.01	B-13

* Boiling Points and boiling ranges are provided for informational purposes. Recognized chloride level for pass/fail is about 3 ppm. In R-290 and R-600a: 2% of other C3 and C4 saturated hydrocarbons are allowed.

6 PACKING

6.1 The material (volume > 500 ml) shall be supplied compressed and liquefied in cylinders conforming to IS 3196 (Part 2) of approved design and of suitable capacity and complying with the requirements of *Gas Cylinder Rules, 2016* with such modifications as may be made from time to time by the Petroleum & Explosives Safety Organization, Government of India, or other duly constituted authority. For the material having volume < 500 ml, suitable packaging shall be done as agreed between the purchaser and manufacturer. The material shall be filled as per filling ratios given under IS 3710.

6.2 The packing, marking, and labelling of cylinders shall be in accordance with the requirements of cylinders for liquid gases given in the *Gas Cylinder Rules, 2016*, with such modifications as may be ordered from time to time by the chief inspector of explosives, Government of India, or any other duly constituted authority. Other containers shall also be marked and labelled in accordance with the instructions issued from time to time by the above-mentioned authority.

6.3 Another prescribed packaging is a non-refillable metal container of approved design and of suitable capacity and complying with the requirements as mentioned in [Table 7](#). The non-refillable metal container should withstand the pressure and should not burst from the body and should leak from the safety device or from the bottom crimping.

6.4 Burst Test

Burst test shall be performed on a sample size of 32 containers drawn from a lot of identical type and design, by subjecting them to hydrostatic test till rupture. The burst pressure test shall be performed with the safety device installed on the containers. Burst pressure is the maximum pressure a vessel or component can withstand before it ruptures.

Each container shall be filled with water, and suitably crimped at the mouth to enable a watertight seal during the test. The test apparatus shall contain a hydrostatic pump capable of developing a pressure at least 3 times the vapour pressure, and a pressure gauge of suitable range having at least count of 1.0 kg/cm².

The pressure shall be gradually increased till the container bursts or shows a leakage. The burst pressure shall be recorded for all 32 containers.

The Cpk value shall be calculated using the formula:

$$Cpk = (\mu - Vp)/3\sigma$$

where

μ = mean burst pressure for 32 observations;

σ = standard deviation of the 32 observations;
and

Vp = designated vapour pressure of the gas at 65 °C.

The sample shall be considered meeting the Burst test requirement if the CpK value is more than 1.67, and the point of rupture was observed in the safety device or the bottom crimp, and not in the body in all the containers.

For gases other than those given in [Table 7](#), suitable packaging shall be done as agreed between the purchaser and manufacturer. The material shall be filled as per filling ratios given under IS 3710.

7 MARKING

7.1 Each container/cylinder shall be marked with the following:

- a) Name of the refrigerants;
- b) Name of the manufacturer and/or his recognized trade-mark, if any;
- c) Net mass, in kg/volume of the refrigerant;
- d) Lot number or batch number or otherwise;
and
- e) Any other statutory marking, painting, labelling and transport of cylinders shall be in accordance with the requirements of the *Gas Cylinder Rules, 2016* with such modifications as may be made from time to time by the petroleum and explosives safety organization, government of India, or other duly constituted authority.

7.2 The cylinders shall also be marked with the appropriate symbol specified in IS 1260 (Part 1) in order to indicate the hazardous nature of the material contained in the cylinder.

7.3 The cylinders shall be color coded in accordance with the requirements of IS 4379.

7.4 BIS Certification Marking

The product(s) conforming to the requirements of this standard may be certified as per the conformity assessment schemes under the provisions of the *Bureau of Indian Standards Act, 2016* and the Rules and Regulations framed thereunder, and the products may be marked with the Standard Mark.

8 INSPECTION AND SAMPLING

8.1 Inspection

All containers in a consignment shall be examined and any cylinder, which shows evidence of leakage, damage or corrosion, shall be rejected.

8.2 Sampling

8.2.1 The number of cylinders to be sampled from a consignment and the criterion for conformity shall be as prescribed in [Annex C](#).

8.2.2 Special precautions should be taken to ensure that representative samples are obtained for analysis.

Sampling shall be done by qualified personnel following accepted sampling and safety procedures. Refrigerants with critical temperatures near or below ambient temperature cannot be reliably sampled for both liquid and vapor phase without special handling.

Table 7 Metal Container Packaging

(Clause 6.3)

Sl No.	Refrigerant	Capacity (Max) ml	Construction Type	MoC	Vapour Gauge Pressure (at 65° C) Kgf/cm ²	cpK (Min)	Filling Ratio (as per P/T Chart)
(1)	(2)	(3)	(4)	(5)	(6)	(7)	(8)
i)	R-134a	500	Two Piece, no side seam	Electrolytic Tin Plate	18.28	1.67	0.92
ii)	R-22	500	Two Piece, no side seam	Electrolytic Tin Plate	26.51	-	0.90
iii)	R-600a	500	Three Piece	Electrolytic Tin Plate	8.95	-	0.49

ANNEX A

(Clause 2)

LIST OF REFERRED STANDARDS

<i>IS No.</i>	<i>Title</i>	<i>IS No.</i>	<i>Title</i>
IS 662 : 2020	Anhydrous ammonia — Specification (<i>second revision</i>)	IS 3710 : 1978	Filling ratios for low pressure liquefiable gases contained in cylinders (<i>first revision</i>)
IS 1260 (Part 1) : 1973	Pictorial marking for handling and labelling of goods: Part 1 Dangerous goods (<i>first revision</i>)	IS 4379 : 2021	Identification of the contents of industrial gas cylinders (<i>second revision</i>)
IS 3196 (Part 2) : 2006	Welded low carbon steel cylinders exceeding 5 litre water capacity for low pressure liquefiable gases: Part 2 Cylinders for liquefiable non-toxic gases other than LPG — Specification (<i>fifth revision</i>)	IS 4905 : 2015/ ISO 24153 : 2009	Random sampling and randomization procedures (<i>first revision</i>)
		IS 7062 : 1973	Glossary of terms used in gas industry
		IS 16656 : 2017/ ISO 817 : 2014	Refrigerants — Designation and safety classification

To access Indian Standards click on the link below:

https://www.services.bis.gov.in/php/BIS_2.0/bisconnect/knownyourstandards/Indian_standards/isdetails/

ANNEX B

(Clause 5, Tables 2, 3, 4, 5 and 6)

METHODS OF TEST FOR REFRIGERANTS

B-1 QUALITY OF REAGENTS

Unless specified otherwise, pure chemicals of purity grade > 99.0 percent pure and distilled water (*see* IS 1070), where water is intended to be used as a reagent, shall be employed in tests.

NOTE — 'Pure chemicals' of purity grade > 99.0 percent pure shall mean chemicals that do not contain impurities which affect the results of analysis.

B-2 TEST SAMPLE

B-2.1 The test samples from the cylinders sampled from a consignment (*see* 8.2) shall be taken either as prescribed in **B-2.1.1** (double valve cylinder) or **B-2.1.2** (single valve cylinder).

B-2.1.1 Take a clean and dry, preheated at 70 °C in oven for 2.0 h, refrigerant sampling cylinder (refrigerant sample cylinder, for example, 50 ml, 500 ml, 1 000 ml stainless steel double ended 1/4-inch FNPT cylinders (1 800 psig), steel cylinder, 2.2 lb, single 9 gauge valve, 3/8 inch pipe neck, disposable can, 17 oz, or other suitable cylinder). Keep the cylinder vertically. Dry the valve of the cylinder with hot gun. Connect the sampling valve with the sampling cylinder with the help of refrigerant gas charging hose pipe. Flush the sampling cylinder by opening the cylinder valve and both valves of sampling cylinder for one minute. Close the valve of the sampling cylinder after the sample cylinder has been filled and also close the valve of the cylinder. Disconnect the sampling cylinder by losing the refrigerant gas hose pipe.

B-2.1.2 Take a clean and dry, preheated at 70 °C in oven for 2.0 h, refrigerant sampling cylinder (refrigerant sample cylinder, for example 50 ml, 500 ml, 1000 ml stainless steel single ended 1/4 inch FNPT cylinders (1 800 psig), steel cylinder, 2.2 lb, single 9 gauge valve, 3/8 inch pipe neck, disposable can, 17 oz, or other suitable single outlet cylinder). Prepare the single ended sampling cylinder by drying the valve of the cylinder with hot gun. Connect the sampling valve of the sampling cylinder with the help of refrigerant gas charging hose pipe

to a vacuum and pull a minimum vacuum of 250 micron. Connect the sampling cylinder to nitrogen and flush the sampling cylinder by fully opening the cylinder valve. Fully close the sampling valve. Connect sampling cylinder to vacuum and fully open valve before pulling a minimum vacuum of 250 micron on the sampling cylinder then fully close the sampling valve. Connect the sampling cylinder to the refrigerant sample and fully open the valve to fill the sampling cylinder with refrigerant sample. Close the valve of the sampling cylinder after the sample cylinder has been filled and also close the valve of the refrigerant supply cylinder. Disconnect the sampling cylinder by losing the refrigerant gas hose pipe.

B-3 DETERMINATION OF MOISTURE IN NEW AND RECLAIMED REFRIGERANTS**B-3.1 Determination of Moisture in New and Reclaimed Refrigerants by Karl Fischer Colourimetric Titration****B-3.1.1 Purpose**

The purpose of this test method is to determine moisture in new and reclaimed refrigerants by the Karl Fischer colourimetric titration method.

B-3.1.2 Principle

Karl Fischer (KF) titration is based upon the redox reaction of water, iodine and sulfur dioxide:

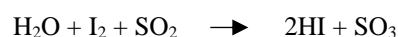

The solvent is typically a mixture of methanol and a weak organic base (imidazole, pyridine, etc.) with the base serving to neutralize the reaction products. In colourimetric KF titrimetric, iodine is generated at the anode in direct proportion to the amount of water introduced, and the end point is detected bi-ampereometrically as the first appearance of excess free I₂. The added refrigerant eventually evaporates; hence, the solvent can be used repeatedly until either the SO₂ or the base solution is consumed.

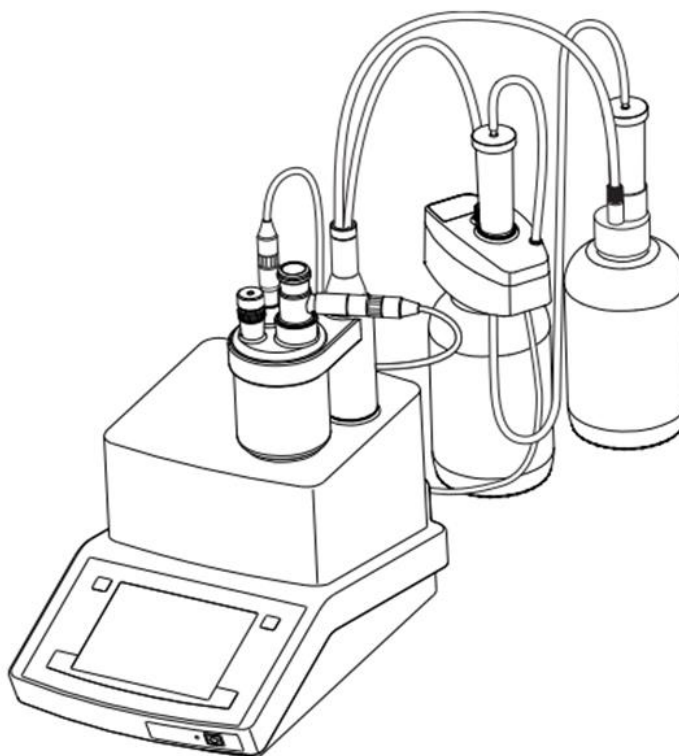

FIG. 1 COULOMETRIC TITRATOR

B-3.1.3 Apparatus (as shown in [Fig. 1](#) and [Fig. 2](#)) and Reagents

B-3.1.3.1 KF colourimetric titrator system — (contains a drying tube for venting refrigerant, anode and cathode solutions, septum, and water vaporizer)

B-3.1.3.2 Desiccant — 20 to 40 mesh

B-3.1.3.3 Desiccator — containing desiccant

B-3.1.3.4 Refrigerant sample cylinder — for example 50 ml, 500 ml, 1 000 ml stainless steel double ended 1/4-inch FNPT cylinders (1 800 psig), steel cylinder, 2.2 lb, single 9-gauge valve, 3/8-inch pipe-neck, disposable can, 17 oz, or other suitable cylinder.

B-3.1.3.5 Stainless steel integral bonnet non-rotating stem valve — 1/4-inch MNPT X 1/4-inch FNPT

B-3.1.3.6 Brass screwed-bonnet needle valve — 1/4-inch MNPT

B-3.1.3.7 Male Luer lock 10 to 32 standard thread

needle connector — cut threads back 1/8 inch (threads are too long as received).

B-3.1.3.8 Needle — 19 gage Luer lock, 4-1/2 inch length.

B-3.1.3.9 1/4 inch compression fitting to 1/4 inch AN female flare adaptor.

B-3.1.3.10 Quick Seal Flare Cap, No. NFT5-4, 1/4 inch tubular seal gasket.

B-3.1.3.11 Sample injection needle and valve attachment (see [Fig. 1](#)). Remove the inner gasket—then drill and tap for a 10/32 inch standard thread through the center of the flare cap. Coat the threads with epoxy—then screw the needle connector ([B-3.1.3.7](#)) into the hole until snug, then allow the epoxy to set overnight. The needle is attached to the connector and the assembly then screwed onto the needle valve AN female flare adapter.

B-3.1.3.12 Syringe — 10 ml, gas tight

B-3.1.3.13 Syringe needle —19 gage-4 inch (deflected point).

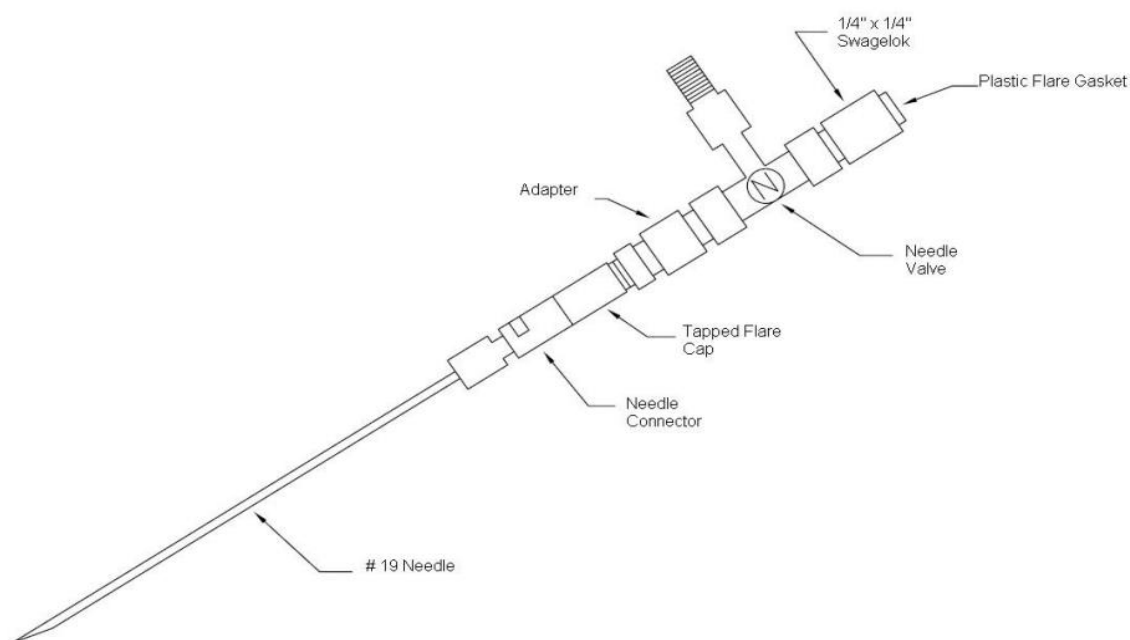

FIG. 2 NEEDLE ATTACHMENT ASSEMBLY FOR CYLINDER SAMPLING

B-3.1.4 Sample Analysis

NOTE — To minimize contamination from moisture, the sample should be introduced directly from the refrigerant sample cylinder into the colourimetric titrator, that is, avoid a secondary container transfer, whenever possible. Also, the effects of moisture contamination and phase distribution will be minimized if the sample container is 60 percent to 80 percent liquid filled with refrigerant. If the sample is a very high-pressure refrigerant, cool the cylinder to approximately 14 K [25.0°F] below critical temperature (TC) of the refrigerant and allow 30 min for equilibrium to be established before starting the analysis.

B-3.1.4.1 Refer to the instruction manual for moisture analyzer installation and operation. Instrument sensitivity should be set at 0.10 and a new septum should be attached.

B-3.1.4.2 Turn-on the analyzer and magnetic stirrer and wait until the background current ($\mu\text{g H}_2\text{O}$ per second) has reached a low, steady level. It may be necessary to "shake" the titration vessel to contact (wash down) any water mist on the upper inside walls with the anode solution. Optimum levels are below 0.10 microgram of water per second (normally 0.02 to 0.05).

B-3.1.4.3 Using a heat gun, dry-off the valve threaded end of the sample cylinder valve that contains a pressure relief valve (350 psi to 400 psi) and cylinder stem valve (1/4-inch MNPT X 1/4-inch FNPT).

B-3.1.4.4 Remove the needle/needle valve attachment (see Fig. 1) from the oven or desiccator and immediately attach to the sample cylinder valve.

B-3.1.4.5 Open the refrigerant sample cylinder valve, then slowly open the needle valve and purge a small amount of sample liquid phase to flush the air from the needle (1 s to 2 s purge). Close both valves.

B-3.1.4.6 Using a heat gun (high position), carefully dry the needle for 20 s to 30 s.

B-3.1.4.7 Weigh the refrigerant sample cylinder plus attachment on a top loader balance (nearest 0.1 g) and record on a work sheet.

B-3.1.4.8 Using a clamp (or clamps) and weighted ring stand, invert and position the sample cylinder such that the needle punctures the septum and is immersed to the hub of the needle. The needle should be submerged about one inch below the KF solution surface.

NOTE — The background current will rise after inserting the needle, then return back to the normal low valve.

B-3.1.4.9 At this juncture it is assumed that the instrument has been turned on, preset for a 5 min titration start delay, verified, and that the background current is at a low (0.02 μg to 0.05 μg) value.

NOTES

1 Do not initiate the titration unless and until the background current has stabilized at a low μg value.

2 The colourimetric titrator background signal (given as $\mu\text{g H}_2\text{O}$ per second) is subtracted from the analyzed result and represents the background moisture presumably accumulated during the time taken to introduce and to titrate

the sample. The background value subtracted is the final value read just before sample addition begins. An artificially elevated background value will result in an erroneously low result (that is negatively biased). Hence, it is important that the background value be as small (but correct) as possible. Often, it is necessary to physically "swirl" the titration cell as to rinse moisture accumulated on the inner walls into the KF solution. This operation normally speeds up the process of reaching a low background signal.

B-3.1.4.10 Ensure that the desiccant tube is clear of obstructions.

B-3.1.4.11 Enter the gross cylinder weight (W_1) from **B-3.1.4.7** into the moisture meter, if applicable, or record the initial weight of the cylinder to the nearest 0.1 g on a worksheet.

B-3.1.4.12 If applicable, remove any prior number displayed for the second weight.

B-3.1.4.13 When the moisture meter is stable (maintains a low background current), initiate a run, slowly open the needle valve and introduce sample at a moderate rate such that no foaming is observed on the KF solution surface. Add at a rate such that 15 g to 20 g of the sample is added over an approximate 10-minute period. Use the sample addition count down (delay) if available.

B-3.1.4.14 Normally, a 20 g sample is desirable for best accuracy. Observe the cell potential reading or microgram reading. If during sample addition this number climbs rapidly to a comparatively large value (range 200 to 300), this means the sample contains high moisture, and a smaller than normal sample size (5 g to 10 g) is sufficient.

B-3.1.4.15 After the proper sample size has been added, initiate the titration, or after the countdown (delay) period ends the coulometer will begin the titration.

NOTE — If the sample contains high moisture, the rate of titration may never exceed the rate of H₂O addition and the titration should be terminated (closing off the needle valve) before too many samples is added. Conversely, if the sample added is small (4 g to 5 g) and the moisture level also is (5 ppm to 10 ppm), to achieve better accuracy, the sample should be reanalyzed using a longer sample addition delay (10 min for example).

B-3.1.4.16 Remove and reweigh the sample cylinder/assembly to the nearest 0.1 g (W_2).

NOTE — If a small sample size is used, a more accurate balance is recommended, and weights should be recorded to the nearest 0.01 g.

B-3.1.4.17 Enter the weight obtain from ($W_1 - W_2$) into the moisture meter if applicable or record the final weight of the cylinder to the nearest 0.1 g on a worksheet.

B-3.1.4.18 Calculate and print-out the ppm or microgram water result.

B-3.1.4.19 Calculation

$$\begin{aligned} & \text{Moisture Concentration, ppm} \\ &= \frac{\text{micrograms of H}_2\text{O}}{\text{grams of sample } (W_1 - W_2)} \end{aligned}$$

Report all results to the nearest 1 ppm. If results are < 2 ppm, report < 2 ppm.

NOTE — Experience has demonstrated that erratic and out-of-specification moisture results are almost always the result of poor and/or improper sampling. Also, be advised that moisture contamination occurs more readily when the relative humidity is high and particular care is required during these times.

B-3.2 Determination of Moisture in New and Reclaimed Refrigerants by Karl Fischer Volumetric Titration

B-3.2.1 Purpose

The purpose of this test method is to determine moisture in new and reclaimed refrigerants by the Karl Fischer volumetric titration method.

B-3.2.2 Principle

Standard Karl Fischer reagent reacts with water in the sample quantitatively and the volume of Karl Fischer reagent consumed directly thus measures the water content of the sample.

B-3.2.3 Apparatus (as shown in [Fig. 1](#)) and Reagents

B-3.2.3.1 KF volumetric titrator system

B-3.2.3.2 Desiccant — 20-40 mesh

B-3.2.3.3 Desiccator — containing Desiccant

B-3.2.3.4 Refrigerant sample cylinder— for example 50 ml, 500 ml, 1000 ml stainless steel double ended 1/4-inch FNPT cylinders (1 800 psig), steel cylinder, 2.2 lb, single 9-gauge valve, 3/8-inch pipe neck, disposable can, 17 oz, or other suitable cylinder.

B-3.2.3.5 Stainless steel integral bonnet non-rotating stem valve, 1/4-inch MNPT X 1/4-inch FNPT.

B-3.2.3.6 Brass screwed-bonnet needle valve, 1/4-inch MNPT.

B-3.2.3.7 Male Luer lock 10-32 standard thread needle connector, cut threads back 1/8 inch (threads are too long as received).

B-3.2.3.8 Needle, 19 gage Luer lock, 4-1/2-inch length.

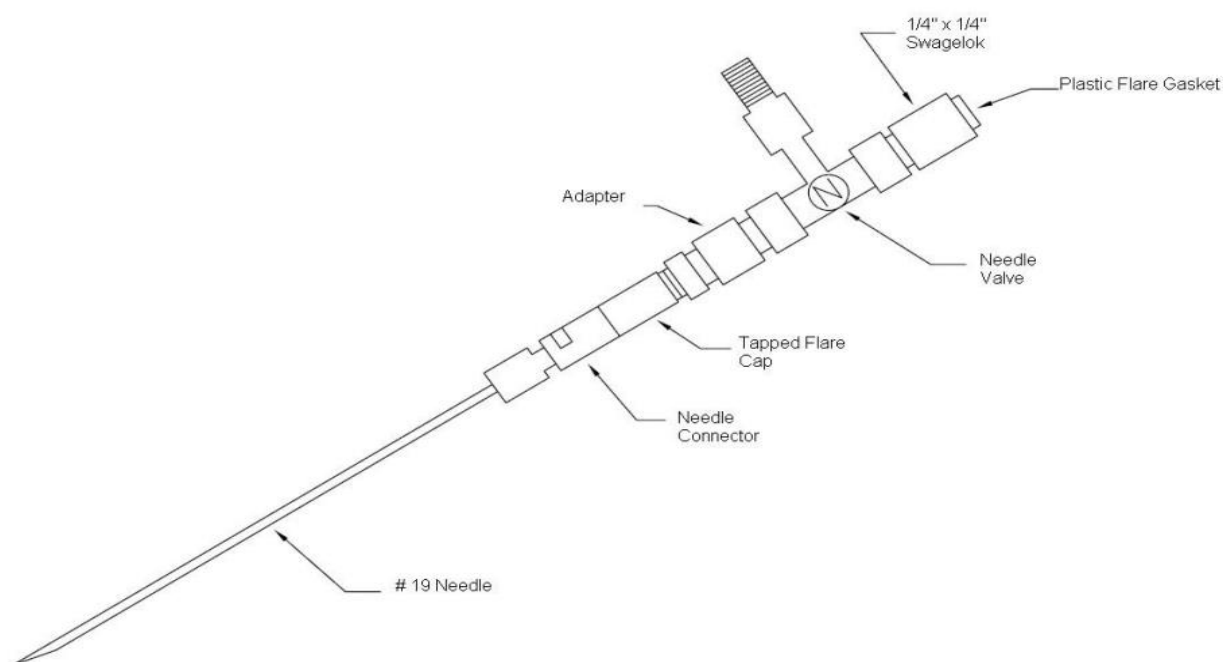

FIG 3. NEEDLE ATTACHMENT ASSEMBLY FOR CYLINDER SAMPLING

B-3.2.3.9 1/4-inch compression fitting to 1/4 inch AN female flare adaptor.

B-3.2.3.10 *Quick Seal Flare Cap*, No. NFT5-4, 1/4-inch tubular seal gasket.

B-3.2.3.11 Sample injection needle and valve attachment (see Fig. 1). Remove the inner gasket-then drill and tap for a 10/32-inch standard thread through the center of the flare cap. Coat the threads with epoxy-then screw the needle connector (see B-3.2.3.7) into the hole until snug, then allow the epoxy to set overnight. The needle is attached to the connector and the assembly then screwed onto the needle valve AN female flare adapter.

B-3.2.3.12 *Syringe*, 10 ml, gas tight

B-3.2.3.13 *Syringe needle*, 19 gage-4 inch (deflected point).

B-3.2.4 *Sample Analysis*

NOTE — To minimize contamination from moisture, the sample should be introduced directly from the refrigerant sample cylinder into the coulometric titrator, that is, avoid a secondary container transfer, whenever possible. Also, the effects of moisture contamination and phase distribution will be minimized if the sample container is 60 percent to 80 percent liquid filled with refrigerant. If the sample is a very high-pressure refrigerant, cool the cylinder to approximately 14 K [25.0°F] below critical temperature (TC) of the refrigerant and allow 30 min for equilibrium to be established before starting the analysis.

B-3.2.4.1 Refer to the instruction manual for moisture analyzer installation and operation.

Instrument sensitivity should be set at maximum start drift at 25.0µg/ml and a new septum should be attached.

B-3.2.4.2 Turn-on the analyzer and magnetic stirrer and wait until the background drift has reached a low, 25 µg/ml level. It may be necessary to "shake" the titration vessel to contact (wash down) any water mist on the upper inside walls. Optimum level of drift is below 25 µg/ml.

B-3.2.4.3 Using a heat gun, dry-off the valve threaded end of the sample cylinder valve that contains a pressure relief valve (350 psi to 400 psi) and cylinder stem valve (1/4-inch MNPT X 1/4-inch FNPT).

B-3.2.4.4 Remove the needle/needle valve attachment (see Fig. 3) from the oven or desiccator and immediately attach to the sample cylinder valve.

B-3.2.4.5 Open the refrigerant sample cylinder valve, then slowly open the needle valve and purge a small amount of sample liquid phase to flush the air from the needle (1 s to 2 s purge). Close both valves.

B-3.2.4.6 Using a heat gun (high position), carefully dry the needle for 20 s to 30 s.

B-3.2.4.7 Weigh the refrigerant sample cylinder plus attachment on a top loader balance (nearest 0.1 g) and record on a work sheet.

B-3.2.4.8 Using a clamp (or clamps) and weighted ring stand, invert and position the sample cylinder such that the needle punctures the septum and is immersed to the hub of the needle. The needle should be submerged about one inch below the KF solution surface.

NOTE — The background current will rise after inserting the needle, then return to the normal low value.

B-3.2.4.9 At this juncture it is assumed that the instrument has been turned on, preset for a 5 min titration start delay, verified, and that the background drift below 25 µg/ml.

NOTE — Do not initiate the titration unless and until the background drift has stabilized at a low µg value.

B-3.2.4.10 Ensure that the desiccant tube is clear of obstructions.

B-3.2.4.11 Enter the gross cylinder weight (W_1) from **B-3.2.4.7** into the moisture meter, if applicable, or record the initial weight of the cylinder to the nearest 0.1 g on a worksheet.

B-3.2.4.12 If applicable, remove any prior number displayed for the second weight.

B-3.2.4.13 When the moisture meter is stable (maintains a low background drift), initiate a run, slowly open the needle valve and introduce sample at a moderate rate such that no foaming is observed on the KF solution surface. Add at a rate such that 20 g to 50 g of the sample is added over an approximate 5-minute period. Use the sample addition count down (delay) if available.

B-3.2.4.14 Normally, a 30 g sample is desirable for best accuracy. If the sample contains high moisture, and a smaller than normal sample size (5 g to 10 g) is sufficient.

B-3.2.4.15 After the proper sample size has been added, initiate the titration, or after the countdown (delay) period ends the volumeter will begin the titration.

B-3.2.4.16 Remove and reweigh the sample cylinder/assembly to the nearest 0.1 g (W_2).

NOTE — If a small sample size is used, a more accurate balance is recommended, and weights should be recorded to the nearest 0.01 g.

B-3.2.4.17 Enter the weight obtain from ($W_2 - W_1$) into the moisture meter if applicable or record the final weight of the cylinder to the nearest 0.1 g on a worksheet.

B-3.2.4.18 Calculate and print-out the ppm water result.

B-3.2.4.19 Calculation

$$\text{Moisture Concentration, ppm} = \frac{\text{volume of KF reagent (ml)} \times \text{Factor of KF Reagent} \left(\frac{\text{mg}}{\text{ml}}\right) \times 1\,000}{\text{grams of sample } (W_1 - W_2)}$$

Report all results to the nearest 1 ppm. If results are < 2 ppm, report < 2 ppm.

NOTE — Experience has demonstrated that erratic and out-of-specification moisture results are almost always the result of poor and/or improper sampling. Also, be advised that moisture contamination occurs more readily when the relative humidity is high and particular care is required during these times.

B-4 DETERMINATION OF NON-CONDENSABLE GASES BY GAS CHROMATOGRAPHY

B-4.1 Purpose

The purpose of this test method is to determine non-condensable gas levels in new and reclaimed refrigerants using gas chromatography.

B-4.2 Test Sample

B-4.2.1 For 5.0 kg to 10.0 kg cylinders sample is not taken for non-absorbable gases but they are directly connected to the gas chromatograph for analysis.

For other big packaging take a clean and dry, sampling cylinder (Refrigerant sample cylinder, for example 50 ml, 500 ml, 1 000 ml stainless steel double ended 1/4-inch FNPT cylinders (1 800 psig), steel cylinder, 2.2 lb, single 9 gauge valve, 3/8 inch pipe neck, disposable can, 17 oz, or other suitable cylinder). Keep the cylinder vertically. Connect the sampling cylinder to the cylinder with the help of refrigerant gas charging hose pipe. Flush the sampling cylinder by opening the cylinder valve and both valves of sampling cylinder for one minute.

Close the valve of the sampling cane after the sampling cane has been filled with vapors. Close the sampling valve of the cylinder also. Disconnect the sampling cylinder by losing the refrigerant gas hose pipe.

B-4.3 Special Apparatus and Reagents

B-4.3.1 Gas chromatograph — equipped with a manual sample injection valve, 1 ml sample loop or auto Gas sampling valve (GSV) and TCD.

B-4.3.2 Gas Chromatographic column — 1.8 m × 3.17 mm [6.0 ft × 0.125 inch] OD stainless steel, divinylbenzene/ethyl vinylbenzene crosslinked

polymers, 80 mesh to 100 mesh.

B-4.3.3 Chromatography data system — capable of electronic integration and processing the chromatographic data.

B-4.3.4 Calibration standard — 1.5 percent by volume, air in Helium, 30 lb cylinder

B-4.3.5 Digital thermometer

B-4.3.6 Temperature probe

B-4.4 Procedure

Chromatographic operating conditions. Set the GC and data integration system as follows:

Detector sensitivity	low sensitivity
Carrier gas flow	30 cc Hydrogen/Helium per minute
Attenuator	× 1 (unattenuated)
Detector temperature, °C [°F]	100 [212]
Injector port temperature, °C [°F]	100 [212]
Head pressure	as required (20 psi suggested)
Column temperature, °C [°F]	100 [212]
Sampling valve	load position
Integrator	External standard method percent volume

B-4.5 Sample Analysis

Analyze the sample using the chromatographic conditions described in [B-4.4](#).

B-4.5.1 Record the temperature to the nearest 0.5 °C [1 °F] of the sample source liquid phase when the vapor phase is taken for analysis. If this information is unknown (customer samples, for example), record as 25.0 °C.

NOTES

1 To reestablish equilibrium in a liquid/vapor phase sample cylinder brought into the laboratory and which has changed temperature to a significant degree from the original temperature (standing several hours, for example), the cylinder must be rolled (to mix) for several minutes before sampling the vapor phase for gas chromatography (GC) analysis. The outer wall temperature of the cylinder below the liquid level should be nearly equivalent to that of the refrigerant contents and can be measured using a suitable thermocouple probe.

2 If the vapor phase of a storage tank, road tanker, ton cylinder, etc, is sampled into a small, evacuated cylinder, regardless of what temperature the small sample cylinder vapor may be when analyzed by gas chromatography, the contents will represent the vapor temperature at the original sample location point.

B-4.5.2 Connect the sample inlet line to the sample cylinder valve which directly accesses the sample vapor phase.

B-4.5.3 Slowly open the sample cylinder valve and slowly purge vapor (about 10 s) to expel air from the sample loop and lines. Cylinders with small headspace (< 500 ml) to evacuate the sampling lines to < 100 to 200 microns and inject on selected pressure.

B-4.5.4 Close the valve and, when the bubbling stops in the exit line beaker of water, immediately rotate the sampling valve to the "Inject" position and immediately start the GC/integration system.

B-4.5.5 Continue the chromatographic separation until the large refrigerant peak returns to the original baseline. Stop the integration.

B-4.5.6 Repeat [B-4.5.3](#) through [B-4.5.5](#) until the air peak area is reproducible (that is, until all system air has been expelled). This may require two or three additional consecutive determinations.

B-4.6 Calculation

B-4.6.1 The data system will calculate the result for air (NCG) in percent by volume, which represents the temperature at which the sample was taken for analysis:

$$\begin{aligned} & \% \text{ by volume NCG} \\ &= \frac{\text{Peak area of sample component}}{\text{Absolute Response Factor (ARF)}} \end{aligned}$$

Calculate the air peak Absolute Response Factor (ARF) for each of the three analyses as follows:

$$\text{ARF} = \frac{\text{Peak area of calibration standard}}{\% \text{ by volume air in calibration standard}}$$

B-4.6.2 Correct the result to percent NCG at 25.0 °C as below. Use the vapor pressure temperature graphs in the ASHRAE handbook of fundamentals.

NOTE — In all liquid/vapor phase refrigerants, the NCG concentration in the vapor phase increases with decreasing temperature of the liquid phase. This is because the vapor concentration of the refrigerant decreases more so than that of air as the temperature drops.

$$C_1 = \frac{C_2 \times P_2 \times K_i}{T_2}$$

where

C_1 = NCG, percent by volume, at 25.0°C;

C_2 = NCG, percent by volume, at the sampling temperature;

K_i = temperature/pressure ratio for refrigerant i at 25.0°C;

P_2 = vapor pressure (psia) of the refrigerant at the sampling temperature, T_2 , in °C. This value is determined from the ASHRAE handbook of fundamentals; and

T_2 = sampling temperature in K (°R), that is, $T_2 = °C + 273.1$.

B-4.6.3 Report results to the nearest 0.01 percent by volume. If results are < 0.02 percent by volume, report as < 0.02 percent by volume.

B-5 BOILING POINT AND BOILING RANGE

B-5.1 Apparatus

B-5.1.1 Boiling Range Flask — double walled evacuated marked flask.

B-5.1.2 Thermometer — suitable thermometer capable of measuring - 50 °C to + 50 °C range with an accuracy of 0.1 percent.

B-5.1.3 Water Bath — capable of regulating bath temperature from - 60 °C to + 80 °C with an

accuracy of 0.1 °C.

B-5.1.4 Stop-Watch — with 0.1 s intervals

B-5.2 Procedure

B-5.2.1 Fill the boiling range flask with 100 ml of the refrigerant and add 2 to 3 crystals of silicon carbide or silica gel of about 800 microns size.

B-5.2.2 Suspend the thermometer in such a way that it does not touch the walls of the tip of the flask.

B-5.2.3 Immerse the tip of the boiling range flask in the water bath at a temperature 35 °C above the boiling point of the refrigerant.

B-5.2.4 As soon as the reading on the thermometer is constant, record the temperature as the initial boiling point of the refrigerant.

B-5.2.5 Continue heating the flask kept in the water bath and record the temperature when 5 ml of the refrigerant has evaporated.

B-5.2.6 Continue the test and take down readings at an interval of every 3 min till 15 ml of the refrigerant is left. Note down this end point.

B-5.2.7 Observe the barometric pressure at the end.

B-5.3 Calculation

B-5.3.1 Boiling Range from 5 percent to 85 percent Evaporation.

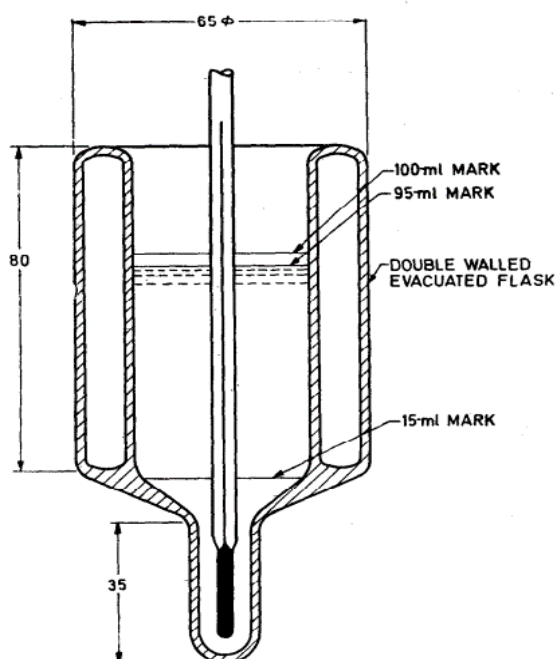

All dimensions in millimetres.
 FIG. 4 TYPICAL BOILING RANGE FLASK

B-5.3.2 Find out the difference in temperature recorded in [B-5.2.5](#) and [B-5.2.6](#) and report as the boiling range from 5 percent to 85 percent evaporation of the refrigerant.

B-5.3.3. Calculate the corrected initial boiling point of the refrigerant by adding to the reading obtained in [B-5.2.4](#), 0.031 °C for each millimeter of difference of average barometric pressure below 760 mm Hg and vice versa.

B-6 ACIDITY

B-6.1 Reagent

B-6.1.1 0.01 N KOH Solution

Pipet 100 ml of 0.1 N KOH solution into a 1 000 ml volumetric flask. Dilute to the mark with absolute methanol and mix thoroughly.

B-6.1.2 0.01 N Sulfuric Acid Solution

Pipet 100 ml of 0.1 N sulfuric acid solution into a 1000 ml volumetric flask. Dilute to the mark with distilled water and mix thoroughly.

B-6.1.3 Extraction Solvent

Add 495 ml of toluene to 495 ml of isopropanol. Add 10 ml of water to the toluene/isopropanol solution and mix thoroughly.

B-6.1.4 Bromothymol Blue Indicator Solution

Dissolve 1 g of bromothymol blue sodium salt in 100 ml of methanol. Mix thoroughly and store in a dropper bottle.

B-6.2 Sample Analysis

B-6.2.1 Thoroughly clean the 100 ml stainless steel cylinder, the valve, the capillary tube, the copper connector and the 250 ml Erlenmeyer flask before initiating testing. Oven heat all of the components to 110 °C [230 °F] and pull a vacuum.

B-6.2.2 Weigh the cylinder assembly to the nearest 0.1 g and designate this weight as "X."

B-6.2.3 Attach the 1/4-inch copper fitting to the vapor valve of the sample cylinder and to the cylinder assembly. Open the vapor valve; loosen the connector and quickly tighten the fitting. This will purge the 1/4-inch connector of air.

B-6.2.4 Invert the sample cylinder with the attached cylinder assembly. Open the sample cylinder valve and then the cylinder assembly valve. Allow the refrigerant to be introduced into the cylinder assembly until 50 g to 75 g of refrigerant is sampled.

B-6.2.5 Close the cylinder assembly valve and set the sample cylinder upright. Close the sample cylinder valve, loosen the 1/4-inch connector and remove the cylinder assembly.

B-6.2.6 Reweigh the cylinder assembly with the refrigerant and designate this value as "Y". The weight of the refrigerant is given by $Y - X =$ grams of refrigerant sampled. (Value for X is in [5.2](#) above).

NOTE — For the low-pressure refrigerants, weigh the sample cylinder before sampling and then add the refrigerant directly to the extraction solvent. Reweigh the sample cylinder and subtract the initial weight from the final weight to obtain the total weight of the refrigerant sampled.

B-6.2.7 Add 100 ml of the prepared extraction solvent to a 250 ml Erlenmeyer flask. Add a clean magnetic stirring bar. Add 6 drops of the indicator solution to the extraction solvent and initiate moderate stirring.

B-6.2.8 If the extraction solvent/indicator solution is yellow, add 0.01 N potassium hydroxide through the burette until a just noticeable difference of blue/green is seen in the extraction solvent. Half drops from the burette may be necessary to achieve the real end point.

B-6.2.9 If the extraction solvent/indicator solution is green or blue, add 0.01 N sulfuric acid through the burette drop wise until the solution is yellow and then proceed as in [B-6.2.8](#) immediately above.

B-6.2.10 Attach the cleaned capillary connector to the cylinder assembly containing the refrigerant sample and slowly introduce the entire sample into the extraction solvent/indicator solution by gradually opening the cylinder valve until it is fully open. The cylinder assembly should be clamped to a ring stand throughout the procedure.

B-6.2.11 Add all the refrigerant sample to the extraction solvent. If the color of the solution is green or blue, the result is reported as "non-detect". If the solution is yellow, record the burette volume to the nearest 0.01 ml (designate this value as V_1) and add 0.01 N KOH drop wise until the green endpoint is reached. Record the final burette volume to the nearest 0.01 ml (designate this value as V_2).

Final volume (designate this value as V_f) of 0.01 N KOH added: $V_f = V_2 - V_1$

B-6.2.12 Calculation of total acidity expressed in ppm as HCl is given by:

$$\begin{aligned} & \text{ppm as HCl} \\ &= \frac{V_f \times \text{normality KOH} \times 36\,500}{\text{refrigerant weight sampled}} \end{aligned}$$

IS 5610 : 2024

NOTE — The value 36 500 is the equivalent weight of HCl (36.5×10^3).

B-7 RESIDUE ON EVAPORATION

B-7.1 Apparatus

B-7.1.1 *Platinum dish* — 100 ml capacity

B-7.1.2 *Water bath* — controlled at $100\text{ }^\circ\text{C} \pm 0.2\text{ }^\circ\text{C}$

B-7.1.3 *Oven* — thermostatic, electrically controlled

B-7.1.4 *Double walled boiling point flask or Goetz graduated centrifuge tube* — 100 ml capacity

B-7.2 Sample Analysis

HBR volume percent measurement and particulates.

B-7.2.1 Measure 100 ml of refrigerant sample into the Goetz bulb.

B-7.2.2 Place the Goetz bulb in a $60.0\text{ }^\circ\text{C}$ [$140\text{ }^\circ\text{F}$] constant temperature water bath. Position the bulb such that it is immersed in the bath to about the 20 ml to 25 ml mark. Do not remove the bulb from the bath until all the refrigerant has completely evaporated (determined by observing the disappearance of refrigerant condensation around the neck of the bulb).

B-7.2.3 Remove the Goetz bulb from the bath, wipe the outside dry and visually measure the ml residue (if any) at the bottom of the burette. Measure to the nearest 0.001 0 ml.

B-7.2.4 If the observed residue is ≤ 0.001 ml, proceed to the calculation section below. If the observed residue is > 0.001 ml, proceed to [B-7.2.5](#).

B-7.2.5 Place the Goetz bulb upright in a $60.0\text{ }^\circ\text{C}$ [$140\text{ }^\circ\text{F}$] oven for 30 min, remove, cool, then measure and record the volume of residue (to the nearest 0.001 ml) in the burette as above. To measure weight percent, save the Goetz bulb-residue for [B-7.3](#).

B-7.2.6 Calculation

$$\text{HBR Volume, \%} = \frac{A \times 100}{B}$$

where

A = volume, of residue (ml) in burette;
and

B = ml, of sample added to bulb ([B-7.2.1](#) above).

NOTE — To calculate the ml of refrigerant samples, divide the weight of the sample by the liquid density of the refrigerant at the ambient sample temperature.

Report all results to the nearest 0.001 percent volume. If results are < 0.001 percent, report as " < 0.001 percent volume."

B-7.3 Sample Analysis

Weight percent measurement.

B-7.3.1 Prepare a platinum dish by rinsing it in acetone and placing it in a $60.0\text{ }^\circ\text{C}$ [$140\text{ }^\circ\text{F}$] oven for at least 30 minutes. Remove (use tweezers) and place in a desiccator until cool (usually 15 min to 20 min).

B-7.3.2 Using tweezers, remove the platinum dish from the desiccator and determine the tare weight (to the nearest 0.000 1g).

B-7.3.3 Add 20 mL of a high purity acetone to the Goetz bulb saved from [B-7.2.5](#). Stopper the bulb and shake to again dissolve the residue and/or to again suspend the particulates (if present) in the solvent.

B-7.3.4 Carefully pour the solution from the Goetz bulb into the platinum dish. Use two approximately 8 ml portions of the acetone to complete the quantitative transfer of residue.

B-7.3.5 Carefully place the platinum dish on the hot water bath and allow the acetone to evaporate.

B-7.3.6 Place the platinum dish in the $60.0\text{ }^\circ\text{C}$ [$140\text{ }^\circ\text{F}$] oven for 30 min, remove and place in the desiccator until cool (20 min to 30 min).

B-7.3.7 Using tweezers, remove the platinum dish, reweigh, and record the difference in weight (from [B-7.3.2](#) above) as the weight of residue.

B-7.3.8 Calculation

$$\text{HBR weight, \%} = \frac{A \times 100}{B}$$

where

A = grams, of residue from [B-7.3.7](#) above;
and

B = grams, of sample taken from [B-7.2.1](#).

NOTE — To determine the g of refrigerant samples, multiply the volume taken times the density.

Report all results to the nearest 0.001 percent volume. If results are < 0.001 Percent, report as " < 0.001 percent volume."

B-8 APPEARANCE, PARTICULATE SOLID AND ODOR

B-8.1 Apparatus

B-8.1.1 *Goetz graduated centrifuge tube* — 100 ml

B-8.1.2 *Conical flask* — 250 ml

B-8.2 Procedure

B-8.2.1 Take 150 ml of liquid sample in a 250 ml conical flask from the sample cylinder.

B-8.2.2 Add sample from the conical flask to the 100 ml mark of the goetz bulb.

B-8.2.3 Examine the sample for color and the presence of insoluble such as packing fibers, rust dirt, etc.

B-8.2.4 Examine the sample for odor by smell it.

B-9 DETERMINATION OF CHLORIDE IN REFRIGERANTS

B-9.1 Special Apparatus and Reagents

B-9.1.1 *Stainless steel capillary tubing*

B-9.1.2 *Top loading balance* — 1 000 g with 0.1 g resolution

B-9.1.3 *Methanol anhydrous reagent*

B-9.1.4 *Silver nitrate*

B-9.1.5 75 ml stainless steel double ended 1/4-inch FNPT cylinder.

B-9.1.6 Two 1/4-inch stainless steel valves with MNPT fittings

B-9.1.7 Two 1/4-inch FNPT X 1/4-inch flare fittings

B-9.1.8 1/16-inch X 1/4-inch stainless steel tube compression fitting reducing union.

B-9.1.9 1/4-inch compression fitting X 1/4-inch flare AN female adaptor.

B-9.1.10 1/4-inch X 1/4-inch copper flare connector.

B-9.1.11 1/4-inch inlet MNPT X 1/4-inch outlet FNPT pressure relief valve.

B-9.2 Stainless Steel Capillary Tubing Connector

Take 1/16-inch X 0.007-inch stainless steel tubing and attach a 1/16" nut and ferrule. Connect this to a 1/16-inch X 1/4-inch compression fitting reducing union and then connect it to the 1/4-inch compression fitting X 1/4-inch flare adaptor. The 1/4-inch flare adaptor can then be connected to the 1/4-inch flare fitting on the cylinder assembly just before each chloride determination.

B-9.3 Cylinder Assembly

The cylinder assembly is used as the sampling apparatus for chloride determination of medium and

high-pressure refrigerants. In order to complete this assembly, all pipe fittings must be tetrafluoroethylene taped to ensure a proper seal at each joint.

B-9.4 Sample Analysis

B-9.4.1 Thoroughly clean the 75 ml stainless steel sample cylinder, the valve, the capillary tube, the copper connector and the 100 ml beaker before initiating testing. Heat all of the components to 110 °C [230 °F] and pull a vacuum.

B-9.4.2 Weigh the cylinder assembly to the nearest 0.1 g and designate this weight as "X".

B-9.4.3 Attach the 1/4-inch copper fitting to the gas valve of the sample cylinder and to the cylinder assembly. Loosen the connector and quickly tighten the fitting.

B-9.4.4 Invert the sample cylinder with the attached cylinder assembly. Open the sample cylinder valve and then the cylinder assembly valve. Allow the refrigerant to be introduced into the cylinder assembly until 30 g to 40 g of refrigerant has been sampled.

B-9.4.5 Close the cylinder assembly valve and set the sample cylinder upright. Close the sample cylinder valve, loosen the 1/4-inch connector and remove the cylinder assembly.

B-9.4.6 Reweigh the cylinder assembly with the refrigerant and designate this value as "Y". The weight of the refrigerant is given by $Y - X = \text{grams of refrigerant sampled}$. (Value for "X" is in [B-9.4.2](#) above).

B-9.4.7 Calculate the volume of refrigerant sampled by,

$$\text{Volume} = \frac{\text{grams sampled}}{\text{density}}$$

B-9.4.8 Add the same volume of methanol as the volume of refrigerant found in [B-9.4.7](#) to a 100 ml beaker. For each 5 ml of methanol used, add three drops of saturated silver nitrate solution to the methanol. Also, add one drop of concentrated nitric acid to the solution before adding the refrigerant sample.

B-9.4.9 Attach the cleaned capillary connector to the cylinder assembly containing the refrigerant sample and slowly introduce the entire sample into the methanolic silver nitrate.

B-9.4.10 If turbidity is present, the test is reported as "fail". If no turbidity exists, the test is reported as "pass".

B-10 DETERMINATION OF PURITY OF R-125, HFC-23, R-290, R-600a and R-152a BY PACKED COLUMN GAS CHROMATOGRAPHY

B-10.1 Special Apparatus and Reagents

B-10.1.1 *Gas chromatograph* — equipped with a packed column injector, flame ionization detector (FID) and capable of oven temperature programming.

B-10.1.2 *Chromatography data system* — capable of electronic integration and processing the chromatographic data. The data system must be configured to capture peak areas enabling measurement of peaks greater than or equal to 0.001 percent by weight.

B-10.1.3 *Gas chromatographic column (Packed)* — 1 percent high molecular weight compounds of

polyethylene glycol and a di-epoxide reacted with acid on (60 to 80) mesh graphitized carbon with a nominal surface area of 100 square meters per gram in a 7.3 m [24 ft], 3.20 mm [0.125 inch] OD stainless steel column. Pre-packed columns are commercially available from multiple vendors.

B-10.1.4 *Polybag* — 125 ml to 500 ml capacity high quality fresh polyethylene polybag or Tedlar bag.

B-10.1.5 *Syringe* — 1 ml, gas tight

B-10.1.6 *Impurities for calibration standard preparation*

These impurities are commercially available.

B-10.2 Chromatographic Operating Conditions

The chromatographic operating conditions are as given in [Table 8](#).

Table 8 GC Operating Conditions

(Clause [B-10.2](#))

SL No.	Condition	R-125 and R-152a
(1)	Detector (2)	FID (3)
i)	Detector temperature, °C [°F]	200 [392]
ii)	Injection port temperature, °C [°F]	200 [392]
iii)	Carrier gas, cc Hydrogen/ Helium (ml) per minute	20
iv)	Sample size, ml (gas syringe)	0.5
v)	Initial column temperature, °C [°F]	50 [122]
vi)	Initial hold, min	6
vii)	Program, °C/min [°F/min]	10 [50]
viii)	Final column temperature, °C [°F]	175 [347]
ix)	Post hold, min	15
x)	Maximum column temperature, °C [°F]	225 [437] (conditioning purposes only)

NOTE — Condition may need to be optimized for specific GC used.

B-10.3 Calibration Standard Preparation and Analysis (Example R-152a)

NOTE — Modify procedure for other refrigerants as necessary.

B-10.3.1 Determine the tare weight of a dry, evacuated vacuumed steel cylinder with a nominal volume of 3 L (cylinder size may differ).

NOTE — The purest stock refrigerant will contain some of the impurities found in the method. The ppm amounts of impurities already in the stock refrigerant are determined via the method of standards addition. Individual impurity peak areas in the stock refrigerant are increased in the calibration standard by the ppm amount of the corresponding impurity added. The ppm already present is combined with the ppm added to give the total ppm component present in the calibration standard.

B-10.3.2 Purge the connecting line using the component with the highest boiling point first (that is, Methylene chloride, the higher boiling component) in order to sweep out air; connect the line to the cylinder.

NOTE — Add the solvent first (that is for Methylene chloride), to add the solvent use the air tight syringe to addition in cylinder.

B-10.3.3 Add the component with the highest boiling point to the cylinder and reweigh the cylinder to the nearest 0.1 g.

NOTE — If the amount added is less than that desired, more may be added. If the amount added is more than that desired, the cylinder may be purged until the desired weight is obtained. Purging the cylinder is permitted only during the addition of the first component.

B-10.3.4 Record the weight of the cylinder plus the component with the highest boiling point. This weight minus the tare weight of the cylinder equals the weight of the component with the highest boiling point.

B-10.3.5 Cool the cylinder in ice water and then add the component with the next highest boiling point in a similar manner. This weight minus the weight recorded in [B-10.3.4](#) equals the weight of the component with the next highest boiling point.

NOTE — It is advisable to add the component with the next highest boiling point so that the weight is less than that desired. If necessary, by adding small additions, it can be brought up to the desired weight. Allow the cylinder and contents to reach ambient laboratory temperature before making the final weighing.

B-10.3.6 After the last component is added, agitate the cylinder by rolling for a minimum of one hour to mix the contents thoroughly. The weight percent of each component can be calculated from the measured weights of the components added. Record the weight percent of each component and date of preparation on the cylinder label. Also record the

total weight of refrigerant in the calibration standard cylinder.

B-10.4 Determination of Component Response Factors

NOTE — Depending upon the data integration system used, it is often more desirable to convert the ppm values to weight percent for response factor calculations and for reporting purposes.

B-10.4.1 Set up the chromatography data system for an area normalization-response factor calibration.

B-10.4.2 Analyze the calibration standard in triplicate using the chromatographic conditions described in Table [B-10.2](#). Calculate the mean of three standard, mean of three standard uses as a standard.

B-10.4.3 Perform the necessary functions to have the data system determine each component relative response factor (RRFi), which is then stored. Response factors are calculated as follows:

$$ARFi = \frac{\text{weight percent in calibration standard}}{A_i}$$

$$ARFr = \frac{100.0000 - S}{A_r}$$

where

A_i = peak area of component i (average of 3 determinations);

A_r = peak area of major refrigerant;

$ARFi$ = absolute response factor of component i;

$ARFr$ = absolute response factor of component r; and

S = weight percent sum of all impurities present.

Then, using the major refrigerant r as the reference peak, the Relative Response Factor can now be determined:

$$RRFi = \frac{ARFi}{ARFr}$$

RRFi values are computed to the nearest 0.0001 unit.

B-10.4 Sampling

Submitted sample cylinders must contain sufficient liquid phase (80 percent liquid full is recommended) for analysis.

B-10.5 Sample Analysis

The sample liquid phase flashed into a polybag or Tedlar bag and the sample for gas chromatography analysis withdrawn from the bag.

B-10.6 Calculations

The weight percentage of each component is calculated as follows:

$$W_i = \frac{RRF_i \times A \times 100}{\sum(A_i \times RRF_i)}$$

where

- A_i = peak area of component i;
 RRF_i = relative response factor for component i;
 W_i = weight percent of component i; and
 $\sum(A_i \times RRF_i)$ = sum of all component peak areas times their respective relative response factors.

B-10.6.2 Report sample component concentrations to the nearest 0.000 1 percent .

B-11 DETERMINATION OF PURITY OF R-22, R-32, R-134a, HFO-1234yf, HFO-1234ze and R-245fa BY CAPILLARY COLUMN GAS CHROMATOGRAPHY

B-11.1 Special Apparatus and Reagents**B-11.1.1 Gas chromatograph**

Equipped with a FID, capillary column split injector, sub ambient cooling valve (liquid N₂), and capillary column capability.

B-11.1.2 Chromatography data system — capable of electronic integration and processing chromatographic data.

B-11.1.3 Gas chromatographic column (Capillary) — 135 m × 0.25 mm, 1 µm df, 6 percent cyanopropyl phenyl-94 Percent dimethyl polysiloxane.

B-11.1.4 Polybag — 125 ml to 500 ml capacity high quality fresh polyethylene polybag or Tedlar bag.

B-11.1.5 Syringe — 1 ml, gas tight

B-11.1.6 Impurities for calibration standard preparation

These impurities are commercially available.

B-11.2 Chromatographic Operating Conditions

The chromatographic operating conditions are given in [Table 9](#).

B-11.3 Calibration Standard Preparation and Analysis (Example R-32)

NOTE — Modify procedure for other refrigerants as necessary.

B-11.3.1 Determine the tare weight of a dry, evacuated vacuumed steel cylinder with a nominal volume of 3 L (cylinder size may different).

NOTE — The purest stock refrigerant will contain some of the impurities found in the method. The ppm amounts of impurities already in the stock refrigerant are determined via the Method of Standards Addition. Individual impurity peak areas in the stock refrigerant are increased in the calibration standard by the ppm amount of the corresponding impurity added. The ppm already present is combined with the ppm added to give the total ppm component present in the calibration standard.

B-11.3.2 Purge the connecting line using the component with the highest boiling point first (that is, Methylene chloride, the higher boiling component) in order to sweep out air; connect the line to the cylinder.

NOTE — Add the solvent first (for Methylene chloride), to add the solvent use the Airtight syringe to addition in cylinder.

B-11.3.3 Add the component with the highest boiling point to the cylinder and reweigh the cylinder to the nearest 0.1 g.

NOTE — If the amount added is less than that desired, more may be added. If the amount added is more than that desired, the cylinder may be purged until the desired weight is obtained. Purging the cylinder is permitted only during the addition of the first component.

B-11.3.4 Record the weight of the cylinder plus the component with the highest boiling point. This weight minus the tare weight of the cylinder equals the weight of the component with the highest boiling point.

B-11.3.5 Cool the cylinder in ice water and then add the component with the next highest boiling point in a similar manner. This weight minus the weight recorded in [B-11.3.4](#) equals the weight of the component with the next highest boiling point.

NOTE — It is advisable to add the component with the next highest boiling point so that the weight is less than that desired. If necessary, by adding small additions, it can be brought up to the desired weight. Allow the cylinder and contents to reach ambient laboratory temperature before making the final weighing.

B-11.3.6 After the last component is added, agitate the cylinder by rolling for a minimum of one hour to mix the contents thoroughly. The weight percent of each component can be calculated from the measured weights of the components added. Record the weight percent of each component and date of preparation on the cylinder label. Also record the total weight of refrigerant in the calibration standard cylinder.

Table 9 GC Operating Conditions(Clause [B-11.2](#))

Sl No.	Condition	R-22	R-134a and R-32	R-245fa
(1)	(2)	(3)	(4)	(5)
i)	Detector	FID	FID	FID
ii)	Carrier gas, cc Hydrogen/ Helium (ml) per minute	1.3	1	1
iii)	Injection port temperature, °C [°F]	200 [392]	200 [392]	200 [392]
iv)	Detector temperature, °C [°F]	200 [392]	200 [392]	200 [392]
v)	Sample, ml	1	1	1
vi)	Initial column temperature, °C [°F]	-20 [-4]	-20 [-4]	-20 [-4]
vii)	Initial hold, mins	14	20	20
viii)	Program 1	20 [68]	20 [68]	20 [68]
	Ramp - °C/mins [°F/mins]	175 [347]	190 [374]	125 [257]
	Column temperature, °C [°F]	6.25	4.50	10.00
	Hold, mins			
ix)	Program 2	-	-	20 [68]
	Ramp - °C/mins [°F/mins]			190 [374]
	Column temperature, °C [°F]			19.50
	Hold, mins			
x)	Total run time, mins	30	35	60
xi)	Split ratio	40:1	40:1	40:1
xii)	Sub-ambient cooling	liquid N ₂	liquid N ₂	liquid N ₂
xiii)	Maximum safe column temperature, °C [°F]	280 [536]	280 [536]	280 [536]

NOTE — Condition may need to be optimized for specific GC used.

B-11.4 Determination of Component Response Factors

NOTE — Depending upon the data integration system used, it is often more desirable to convert the ppm values to weight percent for response factor calculations and for reporting purposes.

B-11.4.1 Set up the chromatography data system for an area normalization-response factor calibration.

B-11.4.2 Analyze the calibration standard in triplicate using the chromatographic conditions described in Table [B-11.2](#). Calculate the mean of three standard, mean of three standard uses as a standard.

B-11.4.3 Perform the necessary functions to have the data system determine each component Relative Response Factor (RRFi), which is then stored. Response factors are calculated as follows:

$$ARFi = \frac{\text{weight percent calibration standard}}{A_i}$$

$$ARFr = \frac{100.0000 - S}{A_r}$$

where

- A_i = peak area of component i (average of 3 determinations);
- A_r = peak area of major refrigerant;
- $ARFi$ = absolute response factor of component i;
- $ARFr$ = absolute response factor of component r; and
- S = weight percent sum of all impurities present.

Then, using the major refrigerant *r* as the reference peak, the Relative Response Factor can now be determined:

$$RRFi = \frac{ARFi}{ARFr}$$

RRFi values are computed to the nearest 0.000 1 unit.

B-11.5 Sampling

Submitted sample cylinders must contain sufficient liquid phase (80 percent liquid full is recommended) for analysis.

B-11.6 Sample Analysis

B-11.6.1 The sample liquid phase flashed into a polybag or Tedlar bag and the sample for gas chromatography analysis withdrawn from the bag.

B-11.7 Calculations

B-11.7.1 The weight percentage of each component is calculated as follows:

$$W_i = \frac{RRF_i \times A_i \times 100}{\sum(A_i \times RRF_i)}$$

where

- A_i = peak area of component i;
- RRF_i = relative response factor for component i;
- W_i = weight percent of component i; and
- $\sum(A_i \times RRF_i)$ = sum of all component peak areas times their respective relative response factors.

B-11.7.2 Report sample component concentrations to the nearest 0.000 1 percent.

B-12 DETERMINATION OF COMPOSITION OF NEW AND RECLAIMED 400 SERIES AND 500 SERIES REFRIGERANT BLENDS BY GAS CHROMATOGRAPHY

B-12.1 Special Apparatus and Reagents

B-12.1.1 *Gas chromatograph* — equipped with a packed column injector and thermal conductivity detector capable of oven temperature programming.

B-12.1.2 *Chromatography data system* — capable of electronic integration and processing the chromatographic data. The data system must be configured to capture peak areas enabling measurement of peaks greater than or equal to 0.001 percent by weight. Peaks that are not identified by the data system should be given a default response factor that is the greater of the average response factors for the calibrated components or R-22. If the peak is identified, then it shall be quantified using its measured response factor.

B-12.1.3 *Gas chromatographic column (Packed)* — 1 percent high molecular weight compound of polyethylene glycol and a di-epoxide reacted with nitroterephthalic acid on (60 to 80) mesh graphitized carbon with a nominal surface area of 100 square meters per gram in a 7.3 m [24 ft], 3.20 mm [0.125 inch] OD stainless steel column. Prepacked columns are commercially available from multiple vendors.

B-12.1.4 *Polybag* — 125 ml to 500 ml capacity high quality fresh polyethylene polybag.

B-12.1.5 *Syringe* — 1 ml, gas tight

Table 10 GC Operating Conditions(Clause [B-12.2](#))

SI No.	Condition	REFRIGERANT BLENDS
(1)	(2)	(3)
i)	Detector	TCD
ii)	Detector current	Low
iii)	Detector temperature, °C [°F]	200 [392]
iv)	Injection port temperature, °C [°F]	200 [392]
v)	Carrier gas	20 ml Hydrogen/Helium per minute
vi)	Reference flow	as required by your GC
vii)	Sample size	0.5 ml (gas syringe)
viii)	Initial column temperature, °C [°F]	40 [104]
ix)	Initial hold	12 min
x)	Program, °C [°F] per minute	15 [59] per min
xi)	Final column temperature, °C [°F]	175 [347]
xii)	Post hold	11 min
xiii)	Maximum column temperature, °C [°F]	225 [437] (conditioning purposes only)

NOTE — Condition may need to be optimized for specific GC used.

B-12.2 Chromatographic Operating Conditions

The chromatographic operating conditions are given in [Table 10](#).

B-12.3 Calibration Standard Preparation and Analysis (Example R-410A)

NOTE — Modify procedure for other refrigerants as necessary.

B-12.3.1 Determine the tare weight of a dry, evacuated vacuumed steel cylinder with a nominal volume of 3 l (cylinder size may differ).

NOTE — The purest stock refrigerant will contain some of the impurities found in the method. The ppm amounts of impurities already in the stock refrigerant are determined via the Method of Standards Addition. Individual impurity peak areas in the stock refrigerant are increased in the calibration standard by the ppm amount of the corresponding impurity added. The ppm already present is combined with the ppm added to give the total ppm component present in the calibration standard.

B-12.3.2 Purge the connecting line using the component with the highest boiling point first (that is, R125, the higher boiling component) in order to sweep out air; connect the line to the cylinder.

NOTE — If the amount added is less than that desired, more may be added. If the amount added is more than that desired, the cylinder may be purged until the desired weight is obtained. Purging the cylinder is permitted only during the addition of the first component.

B-12.3.3 Record the weight of the cylinder plus the component with the highest boiling point. This weight minus the tare weight of the cylinder equals the weight of the component with the highest boiling point.

B-12.3.4 Cool the cylinder in ice water and then add the component with the next highest boiling point in a similar manner. This weight minus the weight recorded in [B-12.3.4](#) equals the weight of the component with the next highest boiling point.

NOTE — It is advisable to add the component with the next highest boiling point so that the weight is less than that desired. If necessary, by adding small additions, it can be brought up to the desired weight. Allow the cylinder and contents to reach ambient laboratory temperature before making the final weighing.

B-12.3.5 After the last component is added, agitate the cylinder by rolling for a minimum of one hour to

ix the contents thoroughly. The weight percent of each component can be calculated from the measured weights of the components added. Record the weight percent of each component and date of preparation on the cylinder label. Also record the total weight of refrigerant in the calibration standard cylinder.

B-12.4 Determination of component response factors.

B-12.4.1 Set up the chromatography data system for an area normalization-response factor calibration.

B-12.4.2 Analyze the calibration standard in triplicate using the chromatographic conditions described in [Table 10](#).

B-12.2. Calculate the mean of three standard, mean of three standard use as a standard

B-12.4.3 Perform the necessary functions to have the data system determine each component relative response factor which is then stored. response factors are calculated as follows:

$$\begin{aligned} & \text{ARF component} \\ & \text{weight percent of component A in} \\ & \text{calibration standard} \\ = & \frac{\text{A component A}}{\text{ARF component B}} \\ & \text{weight percent of component B in} \\ & \text{calibration standard} \\ = & \frac{\text{A component B}}{\text{ARF component i}} \\ & \text{weight percent of component i in} \\ & \text{calibration standard} \\ = & \frac{\text{A component i}}{\text{ARF component i}} \end{aligned}$$

where

- A* = peak area of component (average of three determinations);
- ARF* = absolute response factor; and
- component i* = component 3 or greater.

Then, using component i as the reference peak the relative response factor can now be determined:

$$\begin{aligned} \text{RRF component B} &= \frac{\text{ARF component B}}{\text{ARF component i}} \\ \text{RRF component A} &= \frac{\text{ARF component A}}{\text{ARF component i}} \end{aligned}$$

RRF values are computed to the nearest 0.000 1 unit.

NOTE — The largest peak in the calibration standard chromatogram is selected as the reference peak (RRF = 1.0).

B-12.5 Sampling

Submitted sample cylinders must contain sufficient liquid phase (80 percent liquid full is recommended) for analysis.

B-12.6 Sample Analysis

B-12.6.1 The sample liquid phase flashed into a polybag or Tedlar bag and the sample for gas chromatography analysis withdrawn from the bag.

Alternatively, a vacuum system with sample bulb or flow through method through a tube where a syringe can pierce the tubing to collect the vaporized liquid may also be used.

B-12.7 Calculations

B-12.7.1 The weight percentage of each component is calculated as follows:

$$W_i = \frac{RRF_i \times A_i \times 100}{\sum(A_i \times RRF_i)}$$

where

- A_i* = peak area of component i;
- RRF_i* = relative response factor for component i;
- W_i* = weight, percent of component i; and
- $\sum (A_i \times RRF_i)$ = sum of all component peak areas times their respective relative response factors.

B-12.7.2 Report sample component concentrations to the nearest 0.0001.

B-13 DETERMINATION OF NITROGEN AND OXYGEN CONCENTRATION IN ISOBUTANE SAMPLES BY GAS CHROMATOGRAPHY IN LIQUID PHASE

B-13.1 Apparatus and Reagents

B-13.1.1 Refrigerant sample cylinder, for example, 50 ml, 500 ml, 1 000 ml stainless steel double ended 1/4-inch FNPT cylinders (1 800 psig), steel cylinder, 2.2 lb, single 9-gauge valve, 3/8 inch pipe neck, disposable can, 17 oz, or other suitable cylinder.

B-13.1.2 Refrigerant gas charging hose pipe.

B-13.1.3 Gas chromatograph: equipped with a packed column injector and thermal conductivity detector capable of oven temperature programming. With a manual sample injection valve, 1 ml sample loop or auto gas sampling valve (GSV) and TCD.

B-13.1.4 Chromatography data system: Capable of electronic integration and processing the chromatographic data. The data system must be configured to capture peak areas enabling measurement of peaks greater than or equal to 0.001% by weight.

B-13.1.5 Gas chromatographic column: 13X (80/100 mesh), length: 2 meter × 1/8" internal

diameter: 2 mm or equivalent.

B-13.1.6 N₂ and O₂ standard containing following known amount of concentration as given in [Table 11](#).

B-13.1.7 Frequency

Once in 15 days, standard sample shall be performed to quantify known amount of oxygen and nitrogen concentration (*v/v*, *ppm*) in given sample.

B-13.2 Sampling

Submitted sample cylinders must contain sufficient liquid phase (80 percent liquid full is recommended) for analysis.

B-13.3 Analysis Procedure

Chromatographic operating conditions are given in [Table 12](#).

Table 11 Concentration Composition of N₂O₂ Reference Standard

(Clause [B-13.1.6](#))

SI No.	Impurity	Concentration (<i>v/v</i> , ppm) (approx.)
(1)	(2)	(3)
i)	Oxygen	50
ii)	Nitrogen	50
iii)	Helium	Balance

Table 12 GC Operating Conditions

(Clause [B-13.3](#))

SI No.	Condition	Refrigerant Blends
(1)	(2)	(3)
i)	Detector	TCD
ii)	Detector current	Low
iii)	Detector temperature, °C [°F]	200 [392]
iv)	Injection port temperature, °C [°F]	150 [302]
v)	Carrier gas	30 ml Helium per minute
vi)	Detector reference flow	45 ml/minute
vii)	Sample size	1 ml- loop, injection is done through gas sampling valve (GSV) or 1 ml manual injection by gas tight syringe
viii)	Initial column temperature, °C [°F]	50 [122]
ix)	Initial hold	10 minutes
x)	Final column temperature, °C [°F]	50 [122]
xi)	Maximum column temperature, °C [°F]	225 [437] (conditioning purposes only)
Valve events		
	Time	Position
	0.01	Valve
	0.1	Valve
		Set point
		On
		Off

NOTE — Condition may need to be optimized for specific GC used.

B-13.4 Procedure for Reference Standard Injection with Gas Sampling 6 Port Valve

B-13.4.1 Connect the standard cylinder from pressure gauge outlet at sample injection position attached with micro-gasifier followed by gas sampling valve and transfer line.

B-13.4.2 Then slowly open the pressure gauge valve of the standard cylinder and maintain the pressure at 3 kg than turn the three-way valve in direction of sample injection position.

B-13.4.3 Flush the standard mixture for 30 s to expel air from the sample loop and lines and then fill the loop cautiously with the gas to be examined. Close the two-way valve and press the start button of GC manually.

B-13.5 Procedure for sample injection with gas sampling 6 port valve:

B-13.5.1 Connect the sample inlet line to the sample cylinder valve which directly accesses the sample vapor phase.

B-13.5.2 Slowly open the sample cylinder valve and slowly purge liquid (about 30 s) to expel air from the sample loop and lines.

B-13.5.3 Close the valve and, when the bubbling stops in the exit line beaker of water, immediately rotate the sampling valve to the "Inject" position and immediately start the GC/integration system.

B-13.5.4 Continue the chromatographic separation until the large refrigerant peak returns to the original baseline.

B-13.5.5 If case peak of Nitrogen and Oxygen not clear in blank run, need purging and repetition of blank run. (that is until all system air has been expelled). This may require two or three additional consecutive determinations.

B-13.6 Calculation for Nitrogen and Oxygen Concentration:

B-13.6.1 Individual peak area of sample (after blank correction) /count per ppm of standards to find out the results in percent v/v.

% by volume

$$= \frac{\text{Individual peak area of sample (after blank correction)component}}{\text{Peak area count per ppm}}$$

Calculate the air peak area count per ppm for each of the three analyses as follows:

Peak area counts per ppm

$$= \frac{\text{Individual peak area of Standard}}{\text{ppm by volume air in calibration standard}}$$

B-13.6.2 Reporting of results: Nitrogen and Oxygen in samples are reported in percent v/v.

ANNEX C

(Clause [8.2.1](#))

SAMPLING OF HYDROFLUORO HYDROCARBONS AND CHLOROFLUORO HYDROCARBONS

C-1 SCALE OF SAMPLING

C-1.1 Lot

In any consignment, all cylinders charged during one work-shift from one charging manifold shall be grouped together to constitute a lot.

C-1.2 The number of cylinders to be selected from each lot shall depend on lot size and shall be obtained from col (3) of [Table 13](#) for the corresponding lot size in col (2).

C-1.3 These cylinders shall be selected at random and in order to ensure the randomness of selection, the procedure specified in IS 4905 shall be followed. In case it is not available, following procedure shall be adopted:

Starting from any cylinder in the lot, count them as 1, 2, 3....., up to r and so on in one order where r is

the integral part of N/n . Every rth cylinder thus counted shall be withdrawn to constitute a sample.

C-2 TEST SAMPLES

C-2.1 Test samples shall be drawn from the representative cylinders, in accordance with [Table 13](#).

C-3 NUMBER OF TESTS

C-3.1 All the individual test samples from each lot prepared as shall be tested separately for all the requirements given.

C-3.2 Criterion for Conformity

A lot shall be declared as conforming to the requirements of this specification if all the individual test result satisfy the relevant requirements given in the standard.

Table 13 Number of Cylinders to be Selected

(Clauses [C-1.2](#) and [C-2](#))

SI No.	Lot Size N	Sample Size n
(1)	(2)	(3)
i)	Up to 50	2
ii)	51 to 150	3
iii)	151 to 300	4
iv)	301 to 500	5
v)	501 and over	6

ANNEX D

(Foreword)

COMMITTEE COMPOSITION

Industrial Gases Sectional Committee, CHD 06

<i>Organization</i>	<i>Representative(s)</i>
CSIR - National Physical Laboratory, New Delhi	DR TUHIN KUMAR MANDAL (Chairperson)
Air Liquide, New Delhi	SHRI SUNIL KHER SHRI NAVNEET KUMAR (<i>Alternate</i>)
All India Industrial Gases Manufacturers Association, New Delhi	SHRI SAKET TIKU SHRIMATI VEENA PETER (<i>Alternate</i>)
Automotive Research Association of India, Pune	SHRIMATI YAMINI PATEL SHRI S. D. RAIRIKAR (<i>Alternate</i>)
Bharat Heavy Electrical Limited, Hyderabad	SHRI ABHISHEK KUMAR PANDEY
Centre for fire, explosive & environment safety (CFEES), Delhi	DR MANORAMA TRIPATHI SHRI CHANDRA PRAKASH (<i>Alternate</i>)
Confederation of Indian Industries, New Delhi	SHRI PAWAN MENDIRATTA SHRI SUSHMIT ROY (<i>Alternate</i>)
CSIR – National Physical Laboratory, New Delhi	DR SHANKAR G. AGGARWAL
Directorate General Factory Advice Service and Labour Institutes, Mumbai	DR R. P. BHAVE SHRI P. G. SATPUTE (<i>Alternate</i>)
Directorate General Quality Assurance, Kanpur	SHRI A. K. PATRA SHRI B. B. SAHU (<i>Alternate</i>)
Esteem Gases Pvt Ltd, Mumbai	SHRI SAKET TIKU SHRI UDAY KAMATH (<i>Alternate</i>)
Inox Air Products, Mumbai	SHRI R. L. PARTANI
Indian Oil Corporation (R&D), Faridabad	SHRI RAJESH BADHE DR TAPAN BERA (<i>Alternate</i>)
Linde India Ltd. Kolkata	SHRI PRASENJIT CHAKRABARTI SHRI ARITRA DE (<i>Alternate</i>)
National Test House, Kolkata	DR RAJEEV KUMAR UPDHYAY SHRI S. VEERAPANDIAN (<i>Alternate</i>)
SICGIL India Limited, Chennai	SHRI RUGSHAD DADABHOY SHRI S. MANOJ KUMAR (<i>Alternate</i>)
Steel Authority of India Limited, Ranchi	SHRI MADAN KUMAR
Vanaz Engineers Limited, Pune	SHRI S. J. VISPUTE SHRI J. S. DHUMAL (<i>Alternate I</i>) SHRI HEMANT JOSHI (<i>Alternate II</i>)
BIS Directorate General	SHRI AJAY KUMAR LAL, SCIENTIST 'F'/SENIOR DIRECTOR AND HEAD (CHEMICAL) [REPRESENTING DIRECTOR GENERAL (<i>Ex-officio</i>)]

Member Secretary
SHRI MOHIT GARG
SCIENTIST 'C'/DEPUTY DIRECTOR
(CHEMICAL), BIS

Bureau of Indian Standards

BIS is a statutory institution established under the *Bureau of Indian Standards Act, 2016* to promote harmonious development of the activities of standardization, marking and quality certification of goods and attending to connected matters in the country.

Copyright

BIS has the copyright of all its publications. No part of these publications may be reproduced in any form without the prior permission in writing of BIS. This does not preclude the free use, in the course of implementing the standard, of necessary details, such as symbols and sizes, type or grade designations. Enquiries relating to copyright be addressed to the Head (Publication & Sales), BIS.

Review of Indian Standards

Amendments are issued to standards as the need arises on the basis of comments. Standards are also reviewed periodically; a standard along with amendments is reaffirmed when such review indicates that no changes are needed; if the review indicates that changes are needed, it is taken up for revision. Users of Indian Standards should ascertain that they are in possession of the latest amendments or edition by referring to the website-www.bis.gov.in or www.standardsbis.in.

This Indian Standard has been developed from Doc No.: CHD 06 (25181).

Amendments Issued Since Publication

Amend No.	Date of Issue	Text Affected

BUREAU OF INDIAN STANDARDS

Headquarters:

Manak Bhavan, 9 Bahadur Shah Zafar Marg, New Delhi 110002

Telephones: 2323 0131, 2323 3375, 2323 9402

Website: www.bis.gov.in

Regional Offices:

	Telephones
Central : 601/A, Konnectus Tower -1, 6 th Floor, DMRC Building, Bhavbhuti Marg, New Delhi 110002	{ 2323 7617
Eastern : 8 th Floor, Plot No 7/7 & 7/8, CP Block, Sector V, Salt Lake, Kolkata, West Bengal 700091	{ 2367 0012 2320 9474
Northern : Plot No. 4-A, Sector 27-B, Madhya Marg, Chandigarh 160019	{ 265 9930
Southern : C.I.T. Campus, IV Cross Road, Taramani, Chennai 600113	{ 2254 1442 2254 1216
Western : Manakalya, 5 th Floor/MTNL CETTM, Technology Street, Hiranandani Gardens, Powai Mumbai 400076	{ 25700030 25702715

Branches : AHMEDABAD, BENGALURU, BHOPAL, BHUBANESHWAR, CHANDIGARH, CHENNAI, COIMBATORE, DEHRADUN, DELHI, FARIDABAD, GHAZIABAD, GUWAHATI, HARYANA (CHANDIGARH), HUBLI, HYDERABAD, JAIPUR, JAMMU, JAMSHEDPUR, KOCHI, KOLKATA, LUCKNOW, MADURAI, MUMBAI, NAGPUR, NOIDA, PARWANOO, PATNA, PUNE, RAIPUR, RAJKOT, SURAT, VIJAYAWADA.