सोडियम हाइड्रोसल्फाइड — विशिष्टि
(दूसरा पुनरीक्षण)

**Sodium Hydrosulphite —
Specification**
(*Second Revision*)

ICS 71.060.50

© BIS 2024



भारतीय मानक ब्यूरो
BUREAU OF INDIAN STANDARDS
मानक भवन, 9 बहादुर शाह ज़फर मार्ग, नई दिल्ली - 110002
MANAK BHAVAN, 9 BAHADUR SHAH ZAFAR MARG
NEW DELHI - 110002

www.bis.gov.in www.standardsbis.in

FOREWORD

This Indian Standard (Second Revision) was adopted by the Bureau of Indian Standards, after the draft finalized by the Inorganic Chemicals Sectional Committee had been approved by the Chemical Division Council.

This standard was first published in 1961 and subsequently revised in 1982. In the first revision, specifications of the material for all the three manufacturing processes, that is, zinc process, amalgam process and sodium formate process were covered. In this revision, instrumental test method for the determination of lead has been added as alternate test method. Also, the requirement of bulk density has been suitably modified. In addition to this, editorial corrections have been made wherever required. Also, Amendment and Reference clause have been incorporated. Further, Packing and Marking clause has been updated.

Sodium hydrosulphite, also known as sodium dithionite is used as reducing and bleaching agent in textiles, dyestuffs, leather, paper, pulp and other industries. It is also used for bleaching purposes, in jaggery, sugar manufacture, as a food preservative and in pharmaceutical preparations. This standard, however, does not cover the pharmaceutical grade of the material.

The use of hydrosulphite in jaggery or any other foodstuff industries is in such small quantities that even if the hydrosulphite contains a few ppm of mercury and even assuming all this finds its way to the food product, the same would not be contaminated to the extent as to make it injurious to health. However, it is felt essential to stipulate a maximum limit for mercury to take care of any abnormal increase of its carry over in the product. In this standard a realistic limit of 0.1 parts per million has been specified so that the manufacturers can aim at achieving production of the material within this limit with the existing procedures and equipment.

The composition of the Committee responsible for formulation of this standard is given in [Annex D](#).

For the purpose of deciding whether a particular requirement of this standard is complied with, the final value, observed or calculated, expressing the result of a test or analysis, shall be rounded off in accordance with IS 2 : 2022 'Rules for rounding off numerical values (*second revision*)'. The number of significant places retained in the rounded off value should be the same as that of the specified value in this standard.

Indian Standard
SODIUM HYDROSULPHITE — SPECIFICATION
(Second Revision)

1 SCOPE

This standard prescribes the requirements and the methods of sampling and test for sodium hydrosulphite (Na₂S₂O₄).

2 REFERENCES

The standards listed in [Annex A](#) contain provisions which through reference in this text, constitute provisions of this standard. At the time of publication, the editions indicated were valid. All standards are subject to revision, and parties to agreements based on this Indian Standard are encouraged to investigate the possibility of applying the most recent edition of these standards.

3 GRADES

There shall be two grades of the material, namely:

- a) *Grade 1* — for dyestuff industry; and
- b) *Grade 2* — for textiles, jaggery, garlic bleaching, etc, and as a bleaching agent.

4 REQUIREMENTS**4.1 Description**

The material shall be in the form of granular powder, white to light grey in colour. The material dissolves in water at room temperature, giving initially a clear solution which on standing may become slightly turbid.

4.2 The material shall also comply with the requirements given in [Table 1](#) when tested according to the methods prescribed in [Annex B](#). Reference to the relevant clauses of [Annex B](#) is given in col (4) of the [Table 1](#).

5 KEEPING QUALITY

The material, when stored unopened in original air-tight containers, shall continue to satisfy the

requirements given in [Table 1](#) for at least three months from the date of packing.

6 PACKING AND MARKING**6.1 Packing**

The material shall be packed in air-tight mild steel or fibre board drums with polyethylene liner. Each container shall be securely closed.

6.2 Marking

Each container shall bear legibly and indelibly the following information:

- a) Name and grade of the material;
- b) Name of the manufacturer and his recognized trade-mark, if any;
- c) Gross and net mass;
- d) Date of packing;
- e) Batch number; and
- f) The cautional label 'FLAMMABLE! KEEP IN COOL AND DRY PLACE' and the relevant symbol for labelling dangerous goods [*see* IS 1260 (Part 1)].

6.2.1 BIS Certification Marking

The product(s) conforming to the requirements of this standard may be certified as per the conformity assessment schemes under the provisions of the *Bureau of Indian Standards Act, 2016* and the Rules and Regulations framed there under, and the products may be marked with the standard mark.

7 SAMPLING

The method of drawing representative samples of the material, number of tests to be performed and the methods of finding out the criteria for conformity of the material to the requirements of this specification shall be as prescribed in [Annex C](#).

Table 1 Requirements for Sodium Hydrosulphite*(Clauses [4.2](#) and [5](#))*

| SI No. | Characteristic | Requirement | | Method of Test, Ref to Cl No. in Annex B |
|--------|--|------------------|------------------|--|
| | | Grade 1 | Grade 2 | |
| (1) | (2) | (3) | (4) | (5) |
| i) | Sodium hydrosulphite (as $\text{Na}_2\text{S}_2\text{O}_4$), percent by mass, <i>Min</i> | 88.0 | 84.0 | B-2 |
| ii) | Bulk density, kg/l | 0.9 to 1.6 | 0.9 to 1.6 | B-3 |
| iii) | Zinc (as Zn), mg/kg, <i>Max</i> | 20 | 20 | B-4 |
| iv) | Mercury (as Hg), mg/kg, <i>Max</i> | - | 0.1 | B-5 |
| v) | Heavy metals (as Pb), mg/kg, <i>Max</i> | 10 | 10 | B-6 or B-10 |
| vi) | Sodium formate (as HCOONa), percent by mass, <i>Max</i> | 0.6 | 0.6 | B-7 |
| vii) | Methanol (as CH_3OH) | To pass the test | To pass the test | B-8 |
| viii) | Sodium oxalate (as $\text{Na}_2\text{C}_2\text{O}_4$) | To pass the test | To pass the test | B-9 |

ANNEX A

(Clause 2)

LIST OF REFERRED STANDARDS

| <i>IS No.</i> | <i>Title</i> | <i>IS No.</i> | <i>Title</i> |
|---|--|--|--|
| IS 265 : 2021 | Hydrochloric acid — Specification (fifth revision) | | emission spectrometry (ICP-OES) (first revision) |
| IS 1070 : 2023 | Reagent grade water — Specification (fourth revision) | (Part 65) : 2022/ ISO 17294-2 : 2016 | Application of inductively coupled plasma mass spectrometry (ICP-MS) — Determination of selected elements including uranium isotopes (first revision) |
| IS 1260 (Part 1) : 1973 | Pictorial marking for handling and labelling of goods: Part 1 Dangerous goods | IS 7017 : 1973 | Method for colorimetric determination of traces of heavy metals by dithizone |
| IS 3025 | Methods of sampling and test (physical and chemical) for water and wastewater: | | |
| (Part 2) : 2019/ ISO 11885 : 2007 | Determination of selected elements by inductively coupled plasma optical | | |

To access Indian Standards click on the link below:

https://www.services.bis.gov.in/php/BIS_2.0/bisconnect/knowyourstandards/Indian_standards/isdetails/

ANNEX B

(Clause 4.2 and Table 1)

METHODS OF TEST

B-1 QUALITY OF REAGENTS

Unless specified otherwise, pure chemicals and distilled water (*see* IS 1070) shall be employed in tests.

NOTE — 'Pure chemicals' shall mean chemicals that do not contain impurities which affect the results of analysis.

B-2 SODIUM HYDROSULPHITE**B-2.1 Outline of the Method**

Sodium hydrosulphite is treated with excess of formaldehyde to yield bisulphite formaldehyde and sulphonylate formaldehyde, the latter being determined by titration with iodine.

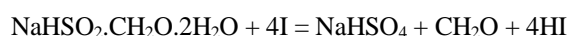
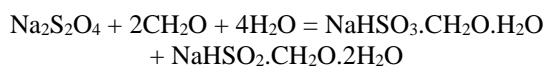
**B-2.2 Reagents**

B-2.2.1 Formaldehyde — 37 percent (v/v). (Commercial 'formalin').

When formalin is acidic, add 0.1 N sodium hydroxide solution to neutralize it to pH 7.

B-2.2.2 Phenolphthalein Indicator Solution

Dissolve 1 g of the material in 100 ml of 90 percent rectified spirit.

B-2.2.3 Starch Indicator Solution

Mix well 1 g of starch and 10 ml of iced water. Add gradually the solution, with stirring, into 200 ml hot water and boil the contents till the solution becomes semi-transparent. Let stand to cool and use the supernatant liquid.

B-2.2.4 Standard Iodine Solution — 0.1 N

Dissolve about 40 g of potassium iodide in about 2.5 ml of water. Add about 13 g of iodine, dissolve and filter through a filter paper. Add water through the filter paper to make about 1 litre. Put the solution in a brown bottle and agitate. Keep it in a dark place. When using, filter again, and determine the factor of the solution as given below.

B-2.2.4.1 Take 25 ml of the solution and titrate with 0.1 N sodium thiosulphate (*see* [B-2.2.5](#)) solution

using starch as indicator. Calculate the factor as follows:

$$N_1 = \frac{V \times N_2}{25}$$

where

N_1 = normality of iodine;

V = volume, in ml, of sodium thiosulphate solution; and

N_2 = normality of sodium thiosulphate solution.

B-2.2.5 Standard Sodium Thiosulphate Solution — 0.1 N

Dissolve 26 g of sodium thiosulphate and about 0.2 g of the anhydrous sodium carbonate in 500 ml of water. Dissolve and make up the volume to 1 litre in a one litre flask. Add about 10 ml of isoamyl alcohol and keep the solution in a stoppered bottle for two days.

B-2.2.5.1 Weigh accurately 1.226 g of potassium dichromate which has been dried for 2 h at (120 ± 2) °C and then cooled in a sulphuric acid desiccator, dissolve in water and make up to 250 ml in a volumetric flask. Take an aliquot of 25 ml in a 500 ml conical flask, add 15 ml of concentrated hydrochloric acid, cool and then add 15 ml of 10 percent potassium iodide solution. Dilute and titrate the liberated iodine against standard thiosulphate solution (*see* [B-2.2.5](#)) using starch as indicator. Calculate this normality of standard sodium thiosulphate as follows:

$$N = \frac{25 \times 0.1}{V}$$

where

N = normality of standard sodium thiosulphate; and

V = volume, in ml, of sodium thiosulphate salt solution used in the titration.

B-2.2.6 Mixed Solution

Take 50 ml of formaldehyde solution (*see* [B-2.2.1](#)) and add 50 ml of water and 10 ml of 0.1 N sodium hydroxide solution and 15 drops of phenolphthalein indicator solution.

B-2.3 Procedure

B-2.3.1 Preparation of the Sample Solution

Weigh accurately about 4 g of the sample in a 1 000 ml volumetric flask with a glass stopper. Dissolve it in 25 ml of the mixed solution. Make up to the mark with water.

B-2.3.2 Pipette about 25 ml of the sample solution (see [A-2.3.1](#)) in a conical flask. Add 0.1 N hydrochloric acid until the red colour of the phenolphthalein disappears. Add 15 ml of one percent acetic acid solution and titrate with iodine solution using starch as an indicator. The end point is the persistence of purple colour for 5s on addition of one drop of the iodine solution.

B 2.4 Calculation

Sodium hydrosulphite, percent by mass

$$= \frac{174 \times N_1 \times V_2}{M}$$

where

N_1 = normality of standard iodine solution,

V_2 = volume, in ml, of iodine solution, and

M = mass, in g, of the material taken for test.

NOTE — 174 is the factor for 0.1 N iodine solution.

B-3 BULK DENSITY

B-3.1 Apparatus

B-3.1.1 Assembly of apparatus is shown in [Fig. 1](#). The base of the measuring cylinder *A* shall be ground flat and the empty measuring cylinder *A* together with the rubber bung shall weigh (250 ± 5) g. It shall be accurately calibrated to 250 ml with an error of less than one millilitre. The distance between zero and 250 ml graduation on the measuring cylinder *A* shall be not less than 220 mm and not more than 240 mm. The distance between the flat ground part of the base of the measuring cylinder *A* and the rubber base pad *B*, when the measuring cylinder *A* is raised to the full height, shall be (25 ± 2) mm.

B-3.1.2 The rubber base pad *B* shall have a shore hardness of 42 to 50.

B-3.1.3 Pans of the balance shall be at least 10 cm in diameter and the balance shall be sensitive to less than 0.1 g.

B-3.2 Procedure

Fold a piece of black glazed paper (25 cm × 25 cm) with two parallel creases to form a channel 12.5 mm

down the middle of the paper. Transfer 50 g of the material on to the glazed paper. Pick up the paper and foam it into a chute. Allow it to lie between the thumb and fingers on the palm of the hand and introduce it into the cylinder, which should be held at 45 °C to the vertical. Slip the powder gently and smoothly into the measuring cylinder without knocking or squeezing. Assemble the apparatus as shown in [Fig. 1](#). With the thumb and four fingers of one hand, gently grasp the upper part of the cylinder, and within one second, lift it as far as 25 mm (see [Fig. 1](#)). Do not jerk the cylinder by knocking it against the upper stop. At the start of the next second, release the cylinder smoothly. Continue lifting and dropping until 300 complete drops have been given. Once every two seconds, a gentle twist of about 10° should be given to the cylinder. As soon as 300 drops have been completed, raise the cylinder to eye level and read the volume of the material.

B-3.3 Calculation

$$\text{Bulk density, kg/l} = \frac{M}{V}$$

where

M = mass, in g, of the material taken for the test; and

V = final volume, in ml, of the material.

B-4 DETERMINATION OF ZINC

B-4.1 Test qualitatively for zinc with the same solution as in quantitative estimation, if found positive, then only the quantitative test may be carried out.

B-4.2 Apparatus

B-4.2.1 Colorimeter

B-4.3 Reagents

B-4.3.1 Standard Zinc Solution

Dissolve 100 mg of zinc powder in slight excess of dilute hydrochloric acid (1 : 1). Dilute to 1 000 ml with water in a volumetric flask. Dilute 10 ml of this solution to 100 ml. One millilitre of this solution contains of 10 µg of zinc.

B-4.3.2 Sodium Ascorbate

B-4.3.3 Potassium Cyanide Solution

Dissolve 1 g of potassium cyanide in 50 ml of water and dilute to 100 ml. The solution is stable for about 60 days.

CAUTION: 'POTASSIUM CYANIDE IS POISON. HANDLE IT WITH CARE'

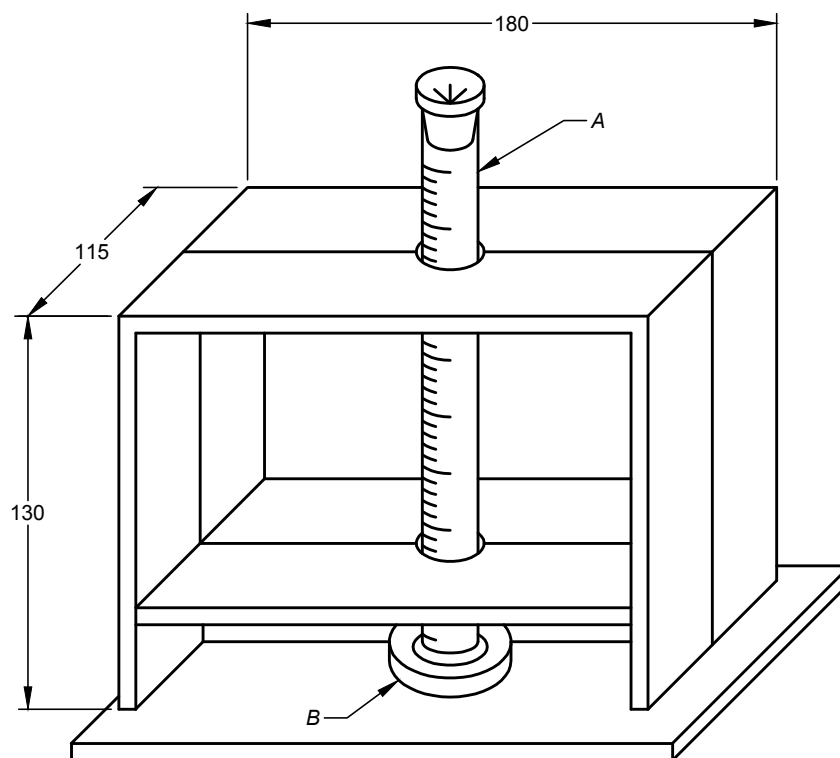

All dimensions in millimetres

FIG. 1 APPARATUS FOR THE DETERMINATION OF BULK DENSITY

B-4.3.4 Buffer Solution (pH 9.0)

Dissolve 40 g of sodium hydroxide in 500 ml of water and dilute to 1 000 ml. Dilute 213 ml of this solution to about 600 ml with water. Dissolve 37.8 g of potassium chloride and 31 g of boric acid in the solution and dilute to one litre.

B-4.3.5 Zincon Solution

Dissolve 130 mg of powdered 2-carboxy - 2'-hydroxy-5'-sulphoformazyl benzene (zincon) in 100 ml of methyl alcohol. Let the solution stand overnight or use a magnetic stirrer in a closed flask to complete dissolution.

B-4.3.6 Chloral Hydrate

Dissolve 10 g of chloral hydrate in 50 ml of water and dilute to 100 ml, filter, if necessary.

B-4.3.7 Concentrated Hydrochloric Acid — see IS 265

B-4.3.8 Sodium Hydroxide Solution — 6 N

B-4.4 Procedure

B-4.4.1 Weigh accurately about 5 g of the material and transfer into a one-litre and one-necked round bottom flask with a long vertical condenser (preferably a condenser in which cold water circulation is through coiled pipes) along with

200 ml of water and 5 ml to 10 ml of concentrated hydrochloric acid, boil and reflux for 2 h to 3 h till all the sulphur dioxide gas is expelled. After refluxing is over, cool, wash down the sides of the condenser and sides of the flask and make up to 1 000 ml, filter, if insoluble residue is present.

B-4.4.2 Transfer 0.0 ml, 0.5 ml, 1.0 ml, 2 ml, 3 ml, 4 ml, 5 ml, and 6 ml quantities of standard zinc solution to provide 0 µg, 5 µg, 10 µg, 20 µg, 30 µg, 40 µg, 50 µg and 60 µg of zinc to 50 ml volumetric flasks. Bring each volume to 10 ml by adding water. To each flask, add in sequence (mixing thoroughly) 0.5 g of sodium ascorbate, 1 ml of potassium cyanide solution, 5.0 ml of buffer solution, 3 ml of zincon solution and 3 ml of chloral hydrate solution; note the time and mix well. Transfer the solution to absorption cell and measure the absorbance at 620 nm exactly after 5 min of adding chloral hydrate solution in a photometer. Use the treated blank (0.0 ml solution of standard zinc) as the reference solution for initial balancing of the colorimeter. Draw a graph of absorbance against concentration (µg of zinc).

B-4.4.3 Take 10 ml of the prepared solution in a 50 ml volumetric flask (see B-4.4). Add 0.5 gm of sodium ascorbate, 1 ml of potassium cyanide solution, 5 ml of Buffer solution, 3 ml of zincon solution; and 3 ml of chloral hydrate solution; note

the time and mix well. Transfer the solution to absorbance cell and measure the absorbance at 620 nm exactly after 5 min of adding chloral hydrate solution in a photo-meter. From the measurement of absorbance, find the concentration from the graph.

B-4.5 Calculation

$$\text{Zinc, mg/kg} = \frac{X \times 100}{M}$$

where

X = concentration, in μg , of zinc, and

M = mass, in g, of the material taken for the test.

B-5 DETERMINATION OF MERCURY

B-5.1 Apparatus

B-5.1.1 Cold Vapour Atomic Absorptiometer — Mercury analyser

B-5.2 Reagents

B-5.2.1 Standard Mercury Solution

Dissolve 1.36 g of mercury chloride in concentrated nitric acid, add 10 ml of potassium dichromate solution (one percent, m/v) and make up to one litre with water (Solution A). One ml of this solution is equivalent to 1 mg of mercury. Dilute this solution as under.

B-5.2.1.1 Take one ml of Solution A in a 1 litre volumetric flask, add 6 ml of dilute nitric acid (two percent v/v) and 3 ml of potassium dichromate solution (one percent, m/v) and make up to the mark. One ml of the solution is equivalent to 1 μg of mercury (Solution B).

B-5.2.1.2 Take 10 ml of Solution B in a 100 ml volumetric flask, add 2 ml of dilute nitric acid (two percent v/v) and one ml of potassium dichromate solution (one percent, m/m). One ml of this solution is equivalent of 0.1 μg of mercury.

B-5.2.2 Stannous Chloride Solution

Take 50 g of stannous chloride in a beaker, add 25 ml of concentrated hydrochloric acid and boil for about 30 min and cool to room temperature. Add 225 ml of water. The solution should be clear. Transfer the solution to 250 ml bottle, add tin pellets and stopper.

B-5.2.3 Sodium Hydroxide Solution — 20 percent (m/v)

B-5.2.4 Dilute Sulphuric Acid — (1 : 1)

B-5.2.5 Potassium Permanganate Solution — 1 percent (m/v)

B-5.2.6 Dilute Nitric Acid — 10 percent (v/v)

B-5.3 Procedure

B-5.3.1 Prepare a solution of the material as prescribed in [B-4.4.1](#).

B-5.3.2 Determine the mercury content with the cold vapour atomic absorptiometer in accordance with the manufacturer's directions.

B-6 DETERMINATION OF HEAVY METALS

B-6.1 Prepare a solution of the material as in [B-4.4.1](#) and determine the heavy metals as prescribed in IS 7017.

B-6.2 Alternative Method

Lead may alternatively be determined by ICP-OES instrumental test method as prescribed at [B-10](#) or ICP-MS method as prescribed in IS 3025 (Part 65).

Instrumental test method using ICP-OES or ICP-MS shall be used as referee method in case of any dispute.

B-7 TEST FOR SODIUM FORMATE

B-7.1 Reagents

B-7.1.1 Sodium Hydroxide — 30 percent

B-7.1.2 Hydrogen Peroxide — 5 percent

B-7.1.3 Dilute Potassium Bromate — 0.1 N

B-7.1.4 Potassium Bromide — solid

B-7.1.5 Potassium Iodide — solid

B-7.1.6 Standard Sodium Thiosulphate Solution — 0.1 N

B-7.1.7 Starch Solution

B-7.2 Procedure

Accurately weigh 3 g of sample with a chemical balance. Put the sample and dissolve in a round-bottom 300 ml acetylation flask in which 50 ml of water and 5 ml of 30 percent NaOH have been placed. Slowly add 50 ml of 5 percent H_2O_2 . Slowly boil for about 30 min to 60 min on direct fire, and oxidize until all sulphur compounds are converted to sulphate. Concentrate the solution to about 25 ml to 30 ml in order to decompose surplus H_2O_2 . After cooling to normal temperature, add accurately 5 ml of 0.0005 percent phenolphthalein solution with a whole pipette, and neutralize with 20 percent HCl. Next, add 30 ml of 0.1 N KBrO_3 with a whole pipette, and further add 4 g of KBr and 20 ml of H_2O . Then add 12 ml of 2N CH_3COONa and 5 ml of 20 percent HCl, immediately connect the flask to a cooling tube, and allow the contents to react for one hour in a water bath of 60 °C. (Use a cooling tube of

1 m long with a diameter of 9 mm provided with a universal joint.)

After completing the reaction, take the flask out of hot bath, and cool for about 5 min in ice-water. While keeping the flask in ice-water, add one g of KI dissolved in 5 ml of H₂O. Add 5 ml of water and 5 ml of 20 percent HCl. Then wash the inside of the cooling tube with 10 ml of water. After 5 min, take the flask out of the ice-water. Remove the cooling tube, and wash the joint with water and put the washings into the flask.

Do not let washings spill out of the flask. Stopper the flask tightly. Next, titrate with 0.1 N Na₂S₂O₃ solution. Add starch indicator when the solution turns to pale yellow and continue the titration until the blue colour disappears. In the blank test, put 5 ml of 30 percent NaOH into a round-bottomed 300 ml acetylation flask, and then add 5 ml of 0.000 5 percent phenolphthalein solution. Neutralize with 20 percent HCl. Add 20 ml of H₂O and 30 ml of 0.1 N KBrO₃ with a whole pipette. Further, add 4 g of KBr and 20 ml of water, and promptly connect the flask to the cooling tube. Carry out further procedures in the same manner.

NOTE — In this analytical operation, stopper the flask immediately after adding the reagents, in order to prevent the escape of Br₂ gas.

B-7.2.1 Reaction Equation

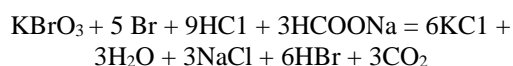
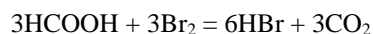
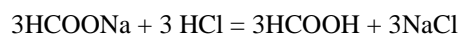
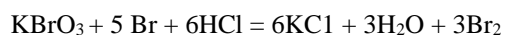

B-7.2.2 Calculation

Sodium formate, percent by mass

$$= \frac{(A - B) \times C \times 0.003\ 4 \times 100}{D}$$

where

A = volume, of thio, solution required for the blank;

B = volume, of thio, required for the titration;

C = normality, of the thio, solution; and

D = mass, in g, of the material taken for test.

NOTE — 1 ml of 0.1 N thio solution is equivalent to 0.003 4 g of sodium formate.

B-8 DETECTION AND ESTIMATION OF METHANOL

B-8.1 Method

Methanol being a highly poisonous substance, normally the same should not be present in this grade of sodium hydrosulphite. However, a very minute trace of it is not likely to do any harm, as the material itself is usually subjected to a processing after the addition of sodium hydrosulphite, although not in all cases. Therefore, it shall be sufficient if a colour test along with a control test is done and the sample should not give more than a very nominal increase in colour than the control.

B-8.2 Apparatus

B-8.2.1 Conical Flasks — of 100 ml capacity

B-8.2.2 Centrifuge

B-8.2.3 Test Tubes

B-8.2.4 Graduated Pipette

B-8.3 Reagents

B-8.3.1 Potassium Permanganate Reagent

Dissolve 30 g of potassium permanganate in 150 ml of phosphoric acid and the volume made up to 1 000 ml.

B-8.3.2 Oxalic Acid Reagent

Dissolved 50 g of oxalic acid in 550 ml of sulphuric acid and volume made up to 1 000 ml. Both the reagents shall be cooled to room temperature.

B-8.3.3 Schiff's Reagent

2 g of fuchsin (p-Rosaniline hydrochloride) is dissolved in about 600 ml of hot water. This is transferred to a two-litre flask, which is kept in ice. Then 40 g of sodium sulphite (Na₂SO₃·7H₂O) dissolved in ice cold water is added to the flask containing fuchsine solution. To this is added 24 ml of concentrated hydrochloric acid drop by drop mixing and shaking vigorously; when a dark red to orange colour will be present. About two g of animal charcoal is added, shaken well and filtered. The filtrate is made up to two litres and kept in refrigerator in a properly closed glass bottle. It must be kept away from light and heat.

B-8.4 Procedure

Take 10 g of sodium hydrosulphite in a 100 ml conical flask and add 50 ml of absolute alcohol

(ethyl), shake well and allow to settle. If a proper settlement does not happen, take a portion of the alcohol layer and centrifuge it. Use the clear solution for testing.

B-8.4.1 *Test in a Test-Tube*

Take 10 ml of the clear alcohol extract in test-tube and add about 5 ml of the potassium permanganate reagent. If the colour of KMnO_4 does not persist add more, but note the quantity of KMnO_4 reagent added totally. Keep the test-tube for about 15 min to 20 min. Then add oxalic acid reagent slowly with stirring till the colour of KMnO_4 is decolorized. (It is advisable to dip the test-tube in ice, while the addition of oxalic acid reagent is made, so that the reaction mixture is kept cool). When the decolorization has happened, add the cold Schiff's reagent (10 ml) along the sides of the test-tube without stirring and keep the test-tube without disturbing for about 30 min to 45 min.

Perform one control test also in another test-tube with all substances, except the extract of sodium hydrosulphite. The sodium hydrosulphite extract is to be replaced with the same amount of absolute alcohol, used in the extraction that is 10 ml.

B-8.4.2 *Observation and Results*

If there is no methanol, no blue colour will be developed, but if any blue colour is developed, which will be from the top portion of the liquid to the bottom, the intensity of the colour shall not be more than a very meagre excess than the control.

B-9 DETERMINATION OF SODIUM OXALATE

B-9.1 *Reagents*

B-9.1.1 *Formaldehyde Solution* — 37 percent

B-9.1.2 *Phenolphthalein Solution*

B-9.1.3 *Dilute Sodium Hydroxide Solution* — 1 N

B-9.1.4 *Glacial Acetic Acid*

B-9.1.5 *Calcium Chloride Solution* — 5 percent

B-9.1.6 *Dilute Acetic Acid Solution*— 5 percent (v/v)

B-9.1.7 *Neutral Formaldehyde Solution*

Take 50 ml formaldehyde solution (37 percent) in a beaker and add four drops of phenolphthalein indicator. To this add dropwise with stirring 1.0 N NaOH till it is faintly alkaline to phenolphthalein. Use this solution for dissolving sodium hydrosulphite.

B-9.1.8 *Dilute Solution of Neutral Formaldehyde*

Neutral formaldehyde made by the above procedure is used to make dilute formaldehyde solution. Take about 15 ml of neutral formaldehyde and about 40 ml to 45 ml of distilled water to get dilute formaldehyde solution.

B-9.1.9 *Calcium Chloride Solution*

About 5 g of calcium chloride is dissolved in 100 ml of water. Solution must be very clear, if not it is to be filtered.

B-9.2 *Apparatus*

B-9.2.1 *Conical Flask* — 100 ml capacity

B-9.2.2 *Volumetric Flask* — 100 ml capacity

B-9.2.3 *Large Test Tubes* — 50 ml capacity

B-9.2.4 *Pipettes*

B-9.2.5 *Beakers*

B-9.3 *Procedure*

Transfer 10 g of sodium hydrosulphite to a 100 ml conical flask containing 30 ml of neutral formaldehyde solution and dissolve by swirling the conical flask gently. Dissolution can be made more quicker by adding small doses of dilute solution of formaldehyde along the sides of the flask and swirling. After all the hydrosulphite has been dissolved, keep the flask for about two to three min without disturbing. Make up the solution to 100 ml in a volumetric flask. While the volume is being made up, add a few drops of dilute acetic acid to discharge the colour of phenolphthalein.

B-9.3.1 Take 25 ml of this solution in a large test tube and add about 1.0 ml of glacial acetic acid, mix and then add about 10 ml of 5 percent calcium chloride solution, which is free from any turbidity and warm the test tube and keep.

B-9.3.2 A control test is also to be carried out along with, which will contain 30 ml neutral formaldehyde solution, an equivalent amount of dilute formaldehyde solution added to the sample, acetic acid; and also calcium chloride solution.

B-9.3.3 Keep both the test tubes for about 15 min and observe whether any turbidity is produced. Any turbidity that may be produced in the test sample should not be a very meagre excess that might be produced in the control test, for the sample to pass test.

B-10 DETERMINATION OF LEAD BY INDUCTIVELY COUPLED PLASMA OPTICAL EMISSION SPECTROMETER (ICP-OES) METHOD

B-10.1 Principle

The sample solution under analysis is nebulized through a nebulizer inside a spray chamber. The aerosol formed is aspirated to argon plasma torch [produced by a radio-frequency inductively coupled plasma (ICP)], where the molecules break into constituent atoms and/or molecular species and atoms are get excited. These excited atoms then return back to the lower energy state by emitting radiation of specific wavelength. These emitted radiations are characteristic of an element and are measured by the Photomultiplier tube detector and intensity of such emitted radiation is directly proportional to the concentration of respective constituent element in the sample.

B-10.2 Recommended Wavelength, Limit of Quantification and Important Spectral Interferences

Elements along with the recommended wavelengths and typical estimated limits of quantification are listed in [Table 2](#). Actual working detection limits are dependent on the type of instrumentation, detection device and sample introduction system used and on the sample matrix. Therefore, these concentrations can vary between different instruments.

Additionally, Table 2 lists the most important spectral interferences at the recommended wavelengths for analysis.

B-10.3 Reagents and Solutions

B-10.3.1. Nitric Acid (65 percent) Suprapure

B-10.3.2 Standard Stock Solution

Either prepare by dissolving proportionate amount of soluble compounds of elements (preferably spectroscopic grade), or use commercially available certified stock solution of 10 µg/ml, 100 µg/ml or 1 000 µg/ml of Lead, Iron, calcium, magnesium, manganese, arsenic, molybdenum, aluminium and mercury in 2 percent to 5 percent nitric acid. It is preferable to prepare single stock solution of multi elemental standards for analysis.

B-10.3.3 Standard Solution

Pipette out 5 ml from 100 µg/ml standard stock solution into a 100 ml volumetric flask and make up volume with 2 percent nitric acid to prepare 5 µg/ml solution. From this 5 µg/ml solution, an aliquot of 1.0 ml, 3.0 ml and 5.0 ml taken in 50 ml volumetric flasks (separate) and make up volume with 2 percent nitric acid to prepare 0.1 µg/ml, 0.3 µg/ml and 0.5 µg/ml solution of respective elements under reference.

B-10.3.4 Sample Preparation

Weigh about 2.5 g of the sample in a 50 ml volumetric flask and add 1.0 ml nitric acid and make up the volume with water.

NOTE — Sample should be clear before injecting to the instrument.

B-10.3.5 Reagent Blank Solution

Place 50 ml of nitric acid and 1 000 ml of water into an HDPE or PP container. For ultra-trace analysis, polytetrafluoroethylene (PTFE) containers should be used. Prior to analysis, make sure that the acid matrix and concentration of the reagent blank solution is the same as in the standard and sample solutions.

Table 2 Recommended Wavelengths, Achievable Limits of Quantification for Different Configuration of Instruments and Important Spectral Interferences

(Clauses [B-10.2](#) and [B-10.4](#))

| Sl No. | Element | Wavelength (nm) | Approximately Achievable Limits | | Interfering Elements |
|--------|---------|--------------------|---------------------------------|-----------------------|----------------------|
| | | | Radial Viewing (µg) | Axial Viewing (µg) | |
| (1) | (2) | (3) | (4) | (5) | (6) |
| i) | Pb | 220.353 | 14 | 5 | Al, Co, Fe, Ti |
| | | 283.305 | (70) | - | Cr, Fe |
| | | 217.00 | - | (20) | - |

B-10.4 Instrument

Set up the instrument as per the manufacturer's instructions manual for recommended operating parameters, based on the manufacturers operating manual and evaluated by internal check analysis using of standard solution of element as well as data selected carefully from [Table 2](#).

For analysis of mercury and arsenic, a gas (hydride)/vapour generating system is coupled with ICP, instead of using of nebulizer. The mercury vapour/arsine generated through the system is carried by the carrier gas (Ar) to plasma torch, and other instrumental conditions shall be the same as above.

NOTE — Sensitivity, instrumental detection limit, precision, linear dynamic range and interference effects will be investigated and established for each individual analyte line on that particular instrument.

B-10.5 Procedure**B-10.5.1 Calibration**

Profile and calibrate the instrument according to the instrument manufacturer's recommended procedures, using the intermediate mixed standard solutions ([B-10.3.5](#)). The relationship between concentration and intensity is linear up to six orders of magnitude. Examine the spectra of the element and make necessary adjustments (if required) for the exact peak positions and baselines to ensure proper measurements of the respective peak intensities. Flush the system with the reagent blank solution between each standard.

B-10.5.2 Before beginning the sample run, re-analyse the reference standard with the highest concentration as if it were a sample. Ensure that the concentration values do not deviate from the actual values by more than ± 5 percent (or the established control limits, whichever is lower). If they do, follow the recommendations of the instrument manufacturer to correct for this condition. Begin the sample run by flushing the system with the reagent blank solution between each sample. It is recommended to analyse a calibration check solution and the calibration blank solution every 10 samples. Analyze the sample solution and calculate the concentration in $\mu\text{g/ml}$ of the lead in the sample solution.

NOTE — It is recommended that IS 3025(Part 2)/ISO 11885 may be referred and practiced for ensuring precise and reproducible analysis.

B-10.6 Calculation

The mass concentrations for each element are determined with the aid of the instrument software by following steps:

- a) Relate emission signals from calibration blank and calibration solutions with the signals from reference elements and establish a calibration plot; and
- b) Determine the mass concentrations of samples with the aid of the emissions and the calibration graphs and calculate the quantity in mg/kg of the constituent elemental impurities in the sample, by multiplying the value by 20 (dilution factor).

ANNEX C

(Clause 7)

SAMPLING OF SODIUM HYDROSULPHITE

C-1 GENERAL REQUIREMENTS OF SAMPLING

C-1.1 In drawing, preparing, storing and handling samples, the following precautions and directions shall be observed.

C-1.2 Samples shall not be taken in an exposed place.

C-1.3 The sampling instrument shall be clean and dry when used.

C-1.4 Precautions shall be taken to protect the samples, the material being sampled, the sampling instrument and the containers for samples from adventitious contamination, particularly from absorption of moisture and acid fumes.

C-1.5 The samples shall be placed in suitable, clean, dry and air-tight glass or any other containers on which the material has no action.

C-1.6 The sample containers shall be of such a size that they are at least three quarters filled with the sample.

C-1.7 Each sample container shall be sealed air-tight with a suitable stopper after filling, and marked with full details of the material (*see* [6.2](#)) and the date of sampling.

C-1.8 Samples shall be stored in a cool and dry place.

C-2 SCALE OF SAMPLING

C-2.1 Lot

All the containers in a single consignment of the material drawn from a single batch of manufacture shall constitute a lot. If a consignment is declared or known to consist of different batches of manufacture, the batches shall be marked separately and the groups of containers in each batch shall constitute separate lots.

C-2.2 For ascertaining the conformity of the material to the requirements of the specification, samples shall be selected and tested for each lot separately.

C-2.3 The number of containers to be selected from a lot shall depend upon the size of the lot and shall be in accordance with [Table 3](#).

Table 3 Scale of Sampling

(Clause [C-2.3](#))

| SI No. | Lot Size | Sample Size |
|--------|---------------|-------------|
| | <i>N</i> | <i>n</i> |
| (1) | (2) | (3) |
| i) | 3 to 15 | 3 |
| ii) | 16 to 40 | 4 |
| iii) | 41 to 65 | 5 |
| iv) | 66 to 110 | 7 |
| v) | 111 and above | 10 |

C-2.3.1 The containers shall be selected at random. In order to ensure the randomness of selection, procedures given in IS 4905 may be used.

C-3 PREPARATION OF TEST SAMPLES

C-3.1 Commercial hydrosulphite powders are usually quite heterogeneous and contain components which tend to segregate because of different crystal sizes. Lack of proper attention, while taking sample, may result in assay errors of as much as 4 percent. Consequently, it is desirable to pay close attention to the instructions given in [C-3.2.1](#) and [C-3.2.2](#), in taking samples for analysis.

C-3.2 From each of the containers selected according to [C-2.3](#), a representative sample of 200 g shall be taken with the help of the sampler given in [C-3.2.1](#). Each of these samples shall constitute individual test sample. This shall be divided into three equal parts and each shall be transferred to a thoroughly dried bottle which shall be suitably secured against contamination. These bottles shall be labelled with all the particulars of the sampling given in [C-1.7](#). One set of individual test samples shall be sent to the purchaser and one to the supplier, and the third set bearing the seals of purchaser and the supplier shall constitute a referee sample to be used in the case of dispute between the two.

C-3.2.1 A suitable sampler is to be used for taking a representative sample of sodium hydrosulphite. This sampler consists of two long concentric cylinders with handle and screw cap at each end. The outer cylinder will have two notches for locking the inner one in position. Both the cylinders have a series of holes; which can coincide as well as close

depending upon the manipulation done with the handle.

Handle is put on the top and screw cap at the bottom. To take sample from the hydrosulphite drum, the sampler is pushed into the body of hydrosulphite. While pushing the sampler, the holes are not in the coinciding positions. When the sampler has reached almost the bottom of the drum, the handle is turned in for the holes in the internal and external cylinders to coincide. By giving a light jerk hydrosulphite from different layers of drum enter the sampler. The holes are closed again by turning the handle. Take the sampler out of the drum. Then the bottom screw is unscrewed and the hydrosulphite is discharged into a sampler bottle. Mix the sample well with a spatula and keep the bottle closed. The capacity of the bottle must be such that, the sample material fills almost three fourth of the bottle capacity, to avoid too much air coming in contact with a small quantity of the sample. This mixed sample is ready for analysis.

C-3.2.2 The portion taken for analysis shall not be removed by pouring from the bottle, but with a spatula or by holding the sample bottle at a slight

incline and pushing a weighing bottle into hydrosulphite until the weighing bottle is filled to the desired level. Pouring the sample from the bottle will have non-representative results because the portion thus secured for analysis will contain a disproportionately large amount of the bigger granules of varying strength.

C-4 NUMBER OF TESTS AND CRITERIA FOR CONFORMITY

C-4.1 Tests for the determination of sodium hydrosulphite bulk density, zinc mercury and heavy metals shall be performed on each of the individual test samples.

C-4.2 From the individual test results obtained for the selected containers, the mean (\bar{X}) and range (R) shall be calculated separately for the sodium hydrosulphite content, bulk density zinc, mercury and heavy metals (range being defined as the difference between the maximum and the minimum of individual test results). The conformity of the lot to the requirements of the specification for the characteristics shall then be determined as follows:

| <i>Sl No.</i> | <i>Characteristic</i> | <i>Criteria for Conformity</i> |
|---------------|--|---|
| (1) | (2) | (3) |
| i) | Sodium hydrosulphite, percent by mass | $= \bar{X} - 0.6 R$ shall be greater than or equal to 84.0 for Grade 2 and 88.0 for Grade 1. |
| ii) | Bulk density, zinc, mercury and heavy metals | $= \bar{X} - 0.6 R$ shall be greater than or equal to 1.1, and $= \bar{X} + 0.6 R$ shall be less than or equal to 1.3. |

ANNEX D

(Foreword)

COMMITTEE COMPOSITION

Inorganic Chemicals Sectional Committee, CHD 01

| <i>Organization</i> | <i>Representative(s)</i> |
|--|---|
| Central Salt and Marine Chemicals Research Institute, Bhavnagar | DR KANNAN SRINIVASAN (<i>Chairperson</i>) |
| Alkali Manufacturers Association of India, Delhi | SHRI K. SRINIVASAN SHRI H. S. DAS (<i>Alternate</i>) |
| Bhabha Atomic Research Centre, Mumbai | DR A. V. R. REDDY DR S. N. ACHARY (<i>Alternate</i>) |
| Central Drugs Standard Control Organization, New Delhi | SHRI C. HARIHARAN |
| Consumer Voice, Delhi | SHRI M. A. U. KHAN SHRI K. C. CHAUDHARY (<i>Alternate</i>) |
| Consumer Education & Research Centre, Ahmedabad | DR ANINDITA MEHTA DR KARTIK ANDHARIA (<i>Alternate</i>) |
| Delhi Jal Board, New Delhi | SHRI ASHUTOSH KAUSHIK |
| Directorate General of Quality Assurance (DGQA), New Delhi | DR A. K. PATRA SHRI B. S. TOMAR (<i>Alternate</i>) |
| Geological Survey of India, Kolkata | SHRI P. V. V. R. SARMA |
| Global Adsorbents Pvt Ltd, Kolkata | SHRI SANJAY DHANUKA |
| Grasim Industries Ltd, Nagda | SHRI ALOK SINGH SHRI PANKAJ GUPTA (<i>Alternate</i>) |
| Gujarat Alkalies and Chemicals Ltd, Vadodara | SHRI V. K. MAHIDA SHRI SHAILESH PATEL (<i>Alternate</i>) |
| Hindalco, Mumbai | SHRI NAGESWAR KAPURI SHRI AJITH RAMACHANDRA (<i>Alternate</i>) |
| Hindustan Lever Ltd, Mumbai | MS VRINDA RAJWADE SHRI SOJAN VARGHESE (<i>Alternate</i>) |
| Indian Chemical Council (ICC), New Delhi | DR UMESH SHETKAR DR RAKESH KUMAR (<i>Alternate</i>) |
| Indian Institute of Chemical Technology, Hyderabad | DR PRAVEEN R. LIKHAR DR RAJENDER REDDY (<i>Alternate</i>) |
| Industrial Carbon Pvt Ltd, Ankleshwar | SHRI SATYAN ROHIT KUMAR |
| Ministry of Chemicals & Fertilizers, New Delhi | DR ROHIT MISRA DR O. P. SHARMA (<i>Alternate</i>) |

| | |
|---|---|
| Ministry of Defence (DGQA), Kanpur | SHRI R. N. APARAJIT |
| MSME - Testing Centre, Kolkata | SHRI PRITENDU MAL SHRI ALAK KUMAR MITRA (<i>Alternate</i>) |
| National Chemical Laboratory, Pune | DR DARBHA SRINIVAS DR PARESH DHEPE (<i>Alternate</i>) |
| National Metallurgical Laboratory, Jamshedpur | DR TRILOCHAN MISHRA SHRI DEVBRATA MISHRA (<i>Alternate</i>) |
| National Mineral Development Corporation Ltd, Hyderabad | SHRI RAJAN KUMAR DR PRASHANT SHARMA (<i>Alternate</i>) |
| National Peroxide Ltd, Mumbai | DR JOY ANTHONY |
| National Physical Laboratory, New Delhi | DR NAHAR SINGH DR S. P. SINGH (<i>Alternate</i>) |
| National Test House, Ghaziabad | MS RICHA KUNDRA |
| Office of the Development Commissioner (MSME), New Delhi | DR KARTHIKEYAN MS ANNA BACKIAM (<i>Alternate</i>) |
| Shriram Institute for industrial research, Delhi | DR LAXMI RAWAT SHRI B. GOVINDAN (<i>Alternate</i>) |
| Tamilnadu Petroproducts Limited, Chennai | SHRI RAVI MUTHUKRISHNAN |
| Tata Chemicals Ltd, Mithapur | SHRI NAJMUL HASAN KHAN |
| The Dharamsi Morarji Chemicals Co. Ltd, Mumbai | SHRI MANDAR GAIKWAD |
| Vaibhav Analytical Services, Ahmedabad | SHRI GAURANG OZA |
| In Personal Capacity (<i>Hari Nagar Co-Op-Society, Gotri Road, Vadodara - 390007</i>) | SHRI R. S. BAGHEL |
| In Personal Capacity (<i>514 Veer Apt, Sector 13, Rohini, New Delhi - 110085</i>) | SHRI D. K. JAIN |
| BIS Directorate General | SHRI A. K. LAL, SCIENTIST 'F'/SENIOR DIRECTOR AND HEAD (CHEMICAL) [REPRESENTING DIRECTOR GENERAL (<i>Ex-officio</i>)] |

Member Secretary
SHRI SAGAR SINGH
SCIENTIST 'D'/JOINT DIRECTOR
(CHEMICAL), BIS

Bureau of Indian Standards

BIS is a statutory institution established under the *Bureau of Indian Standards Act, 2016* to promote harmonious development of the activities of standardization, marking and quality certification of goods and attending to connected matters in the country.

Copyright

BIS has the copyright of all its publications. No part of these publications may be reproduced in any form without the prior permission in writing of BIS. This does not preclude the free use, in the course of implementing the standard, of necessary details, such as symbols and sizes, type or grade designations. Enquiries relating to copyright be addressed to the Head (Publication & Sales), BIS.

Review of Indian Standards

Amendments are issued to standards as the need arises on the basis of comments. Standards are also reviewed periodically; a standard along with amendments is reaffirmed when such review indicates that no changes are needed; if the review indicates that changes are needed, it is taken up for revision. Users of Indian Standards should ascertain that they are in possession of the latest amendments or edition by referring to the website-www.bis.gov.in or www.standardsbis.in.

This Indian Standard has been developed from Doc No.: CHD 01 (25377).

Amendments Issued Since Publication

| Amend No. | Date of Issue | Text Affected |
|-----------|---------------|---------------|
| | | |
| | | |
| | | |
| | | |

BUREAU OF INDIAN STANDARDS

Headquarters:

Manak Bhavan, 9 Bahadur Shah Zafar Marg, New Delhi 110002

Telephones: 2323 0131, 2323 3375, 2323 9402

Website: www.bis.gov.in

Regional Offices:

Central : 601/A, Konnectus Tower -1, 6th Floor,
DMRC Building, Bhavbhuti Marg, New
Delhi 110002

Telephones

{ 2323 7617

Eastern : 8th Floor, Plot No 7/7 & 7/8, CP Block, Sector V,
Salt Lake, Kolkata, West Bengal 700091

{ 2367 0012
{ 2320 9474

Northern : Plot No. 4-A, Sector 27-B, Madhya Marg,
Chandigarh 160019

{ 265 9930

Southern : C.I.T. Campus, IV Cross Road, Taramani, Chennai 600113

{ 2254 1442
{ 2254 1216

Western : 5th Floor/MTNL CETTM, Technology Street, Hiranandani Gardens, Powai
Mumbai 400076

{ 25700030
{ 25702715

Branches : AHMEDABAD, BENGALURU, BHOPAL, BHUBANESHWAR, CHANDIGARH, CHENNAI, COIMBATORE, DEHRADUN, DELHI, FARIDABAD, GHAZIABAD, GUWAHATI, HARYANA (CHANDIGARH), HUBLI, HYDERABAD, JAIPUR, JAMMU, JAMSHEDPUR, KOCHI, KOLKATA, LUCKNOW, MADURAI, MUMBAI, NAGPUR, NOIDA, PARWANOO, PATNA, PUNE, RAIPUR, RAJKOT, SURAT, VIJAYAWADA.