

**AMENDMENT NO. 1 DECEMBER 2024**  
**TO**  
**IS 4989 : 2018 FOAM CONCENTRATE FOR PRODUCING MECHANICAL FOAM**  
**FOR FIRE FIGHTING — SPECIFICATION**  
( *Fourth Revision* )

(*Third cover page, foreword, para 3*) — Substitute ‘Annex P’ for ‘Annex N’.

[*Page 1, clause 2, IS 1206 (Part 3) : 1978*] — Substitute the following for the existing:

<i>‘IS No.</i>	<i>Title</i>
IS 1206 (Part 3) : 2021	Methods for testing tar and bituminous materials — Determination of viscosity: Part 3 Kinematic viscosity ( <i>second revision</i> )’.

[*Page 4, Table 1, Sl No. (vi), col (11)*] — Substitute the following for the existing:

*‘For Newtonian Fluids* — Using viscometer, size no. 150 of Table 1 of IS 1206 (Part 3) and this may also be used for the viscosity lower than 2.1 cst also.

*For Non-Newtonian Fluids* — Digital viscometer with suitable spindle type and speed as declared by the manufacturer.’

[*Page 4, Table 1, Sl No. (ii), col (11)*] — Substitute ‘**A-3**’ for ‘**A-2**’.

[*Page 4, Table 1, Sl No. (ix), col (7)*] — Substitute ‘33.00’ for ‘—’.

[*Page 5, Table 2, header, col (7)*] — Substitute ‘**SF 0.1 to 6**’ for ‘**SF 1, 3 and 6**’.

[*Page 5, Table 2, Sl No. (iv)*] — Insert the following at the end:

**Price Group 4**

**Amendment No. 1 to IS 4989 : 2018**

SI No.	Test Parameters ↓ TYPE →	AFFF	PF	FP	FFFP	SF	AR-AFFF	AR-FFFP	AR-FP	Test Method, Ref to Annex
(1)	(2)	1, 3 and 6	3 and 6	3 and 6	3 and 6	0.1 to 6	3/3 and 3/6	3/3 and 3/6	3/3 and 3/6	(11)
v)	Fire test for synthetic foam:									Annex N
	a) For class A fire:									
	1) Wood crib fire test	–	–	–	–	The foam shall be able to extinguish the test fire.	–	–	–	
	2) Deep seated fire test	–	–	–	–	The runoff for foam shall be less than water.	–	–	–	
	3) Wood fireboard penetration	–	–	–	–	Weight loss for foam shall be less than water.	–	–	–	
	b) For class B fire	–	–	–	–	Foam shall be able to extinguish the test fire in two consecutive tests.	–	–	–	

NOTE — The concentration of synthetic foam for use as wetting agent to be declared by the manufacturer.

(Page 6, Annex A, clause A-2) — Insert the following at the end:

**A-3 FREEZING AND THAWING**

**A-3.1 Apparatus**

The usual laboratory apparatus and, in particular, the following:

- a) *Freezing Chamber* — capable of achieving the temperatures required in A-3.2;
- b) *Polyethylene Tube* — approximately 10 mm in diameter, approximately 400 mm long, sealed and weighed at one end with suitable spacers attached; and
- c) *Measuring Cylinder* — glass of 500 ml capacity, approximately 400 mm high and approximately 65 mm in diameter, with a stopper.

See Fig. 7 for a typical form of the apparatus.

**A-3.2 Procedure**

**A-3.2.1** Set the temperature of the freezing chamber [see A-3.1(a)] to at least 10 °C below the freezing point of the sample.

**A-3.2.2** To prevent the glass measuring cylinder [see A-3.1(c)] from breaking due to expansion of the foam concentrate on freezing, insert the tube [see A-3.1(b)] into the measuring cylinder with the sealed end downward, weighed if necessary to avoid flotation, the spacers ensuring it remains approximately on the central axis of the cylinder. Fill the cylinder and fit the stopper.

**A-3.2.3** Place the cylinder in the freezing chamber, cool it and maintain at the required temperature for 24 h at the end of this period, thaw the sample for not less than 24 h and not more than 96 h in an ambient temperature of 27 °C ± 5 °C.

**A-3.2.4** Repeat three times to give four cycles of freezing and thawing before testing. Examine the sample for stratification and non-homogeneity.

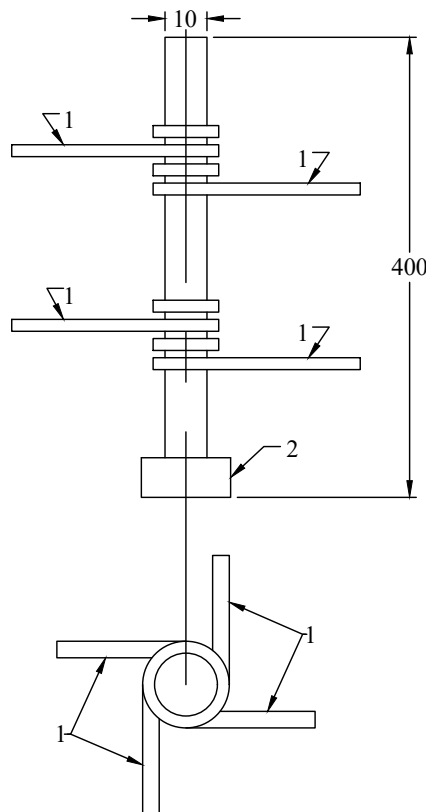

Key

- 1 Spacers (for example, plastic cable strap)
- 2 Mass at sealed end

All dimensions are in millimetres.

FIG. 7 TYPICAL FORM OF TEST APPARATUS

(Page 7, clause **D-1**, informal table, last row) — Substitute ‘Distilled water for miscibility test and potable water for fire test’ for ‘Distilled water’.

(Page 8, clause **F-2**, formula) — Substitute the following for the existing:

$$\text{‘Sludge content, percent} = \frac{\text{Weight of sludge content of the sample}}{\text{Volume of foam (50/100 ml)} \times \text{Specific gravity}} \times 100\text{’}.$$

(Page 19, clause **M-11**) — Insert the following at the end:

**‘ANNEX N**

(Table 2)

**FIRE TESTS FOR SYNTHETIC FOAMS**

**N-1 CLASS A FIRE EXTINGUISHMENT TEST**

**N-1.1 General**

Synthetic foam for use on class A fires shall pass all the fire tests specified in this annex.

**N-1.2 Wood Crib Fire Test**

**N-1.2.1** The ability of a wetting agent solution to extinguish wood crib fires shall be determined with the solution prepared at the minimum concentration specified for use by the manufacturer.

**N-1.2.2** Tests shall be conducted according to the procedures detailed in this section and as per **8.3** of IS 15683 for class A fires utilizing a 3A wood crib.

**N-1.2.3** The solution shall be applied with a nominal 9 litre certified 2A rated water extinguisher.

**N-1.3 Deep-Seated Fire Test**

**N-1.3.1** Wetting agent solutions shall extinguish deep-seated cotton fires and exhibit less runoff than water when tested in accordance with **N-1.3.2** and **N-1.3.3**.

**N-1.3.2** Tests shall be conducted three times with plain water and three times with the wetting agent solution prepared at the manufacturer's recommended concentrations.

**N-1.3.3** The tests shall be conducted using a cylindrical basket of perforated sheet steel, 110 mm in diameter and 180 mm high, and ginned cotton weighing 100 g shall be used and the test conducted as follows:

- a) Stuff 50 g of cotton into the bottom half of the basket;
- b) Heat a steel rod 35 mm in diameter and 33 mm long to > 593 °C;
- c) Place the rod on the cotton in the basket;
- d) Immediately insert 50 g of cotton into the basket on top of the rod;
- e) Pour 250 ml of test liquid (water or wetting agent solution) onto the cotton and catch the runoff in a pan placed below the basket; and
- f) Measure and record the volume of runoff.

#### **N-1.4 Wood Fibreboard Penetration**

**N-1.4.1** Wetting agent solutions shall extinguish wood fibreboard fires and exhibit less runoff and weight loss than water when tested in accordance with **N-1.4.2** and **N-1.4.3**.

**N-1.4.2** Tests shall be conducted three times with plain water and three times with the wetting agent solution prepared at the manufacturer's recommended concentrations.

**N-1.4.3** Penetration tests shall be conducted as follows:

- a) Weigh fibre insulation board measuring 300 mm × 300 mm × 5 mm and place them on a wire grid;
- b) Expose each insulating board sample to an alcohol flame from a burning pan that is placed immediately below the sample board;
- c) Expose the flame to the board for 100 s;
- d) Remove the fuel pan and place a clean, dry pan under the board to collect the water or agent runoff;
- e) Spray 250 ml of test liquid (water or wetting agent solution) on the upper surface of the insulation board using a small sprinkler bottle;
- f) Place pans underneath the board to catch any runoff that occurs;
- g) Measure and record the volume of runoff; and
- h) Dry for 3 h at 105 °C ± 5 °C and weigh the boards and calculate the weight loss.

#### **N-2 CLASS B FIRE EXTINGUISHMENT TESTS**

##### **N-2.1 General**

Products for use on class B fires shall pass all the fire tests specified in this clause.

##### **N-2.2 Listing**

Wetting agent solutions at the concentrations specified by the manufacturer shall be evaluated to and shall comply with the requirements given in **8.4** of IS 15683.

##### **N-2.3 Test Method**

Tests for class B fires shall be conducted as follows:

- a) A pan fitted as described in SI No. (ix) of Table 8 of IS 15683 with a backboard that is the width of the backboard and 90 cm high shall be used;
- b) A layer of heptane fuel shall be floated as per SI No. (ix) of Table 8 of IS 15683;
- c) The fuel in the pan shall be ignited and allowed to free burn for 60 s;
- d) A 38 lpm nozzle (*see* Fig. 8) shall be used to apply the wetting agent solution to the fire using one, or a combination, of the following methods:
  - 1) The nozzle shall be fixed in position at an angle above the horizontal to direct the discharge across the pan onto the backboard for the entire duration of the test; and
  - 2) The nozzle shall be permitted to be moved as necessary for control and extinguishment.
- e) In no case shall the nozzle extend over any part of the test pan; and
- f) The fire shall be extinguished within 5 min of the start of application of the wetting agent solution.

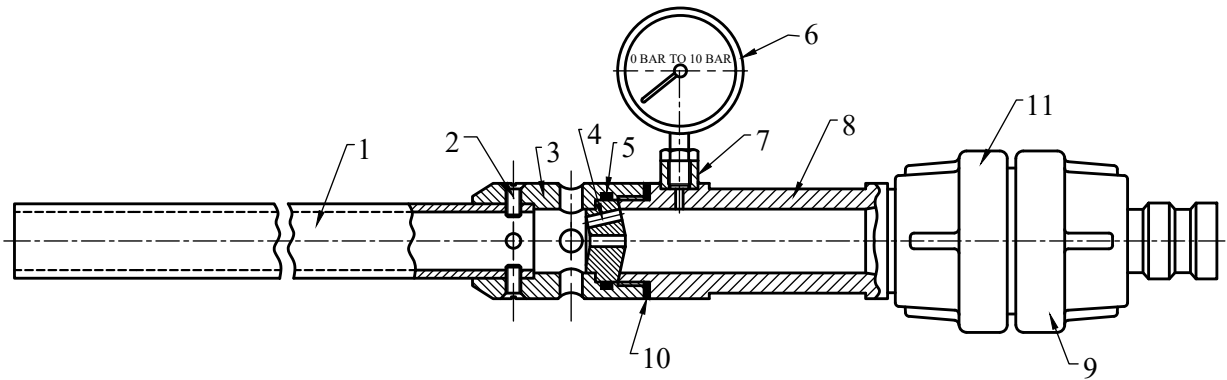

Key

- 1 Jet pipe
- 2 Screw
- 3 Nozzle housing
- 4 Intermediate head
- 5 Seal
- 6 Pressure gauge
- 7 Molds
- 8 Connector
- 9 Suction coupling
- 10 Sealing ring
- 11 Coupling

FIG. 8A OVERALL NOZZLE ASSEMBLY

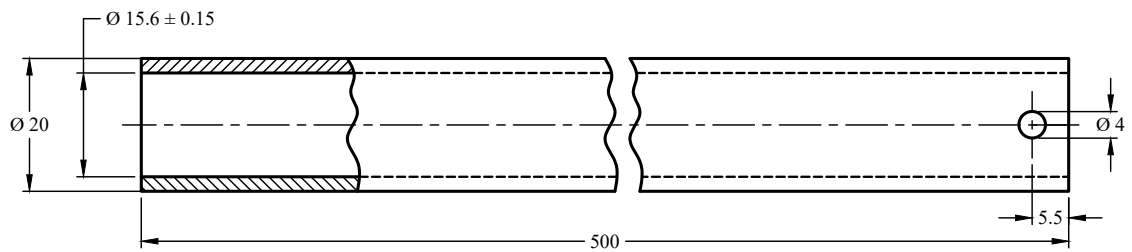

FIG. 8B JET PIPE ASSEMBLY VIEW

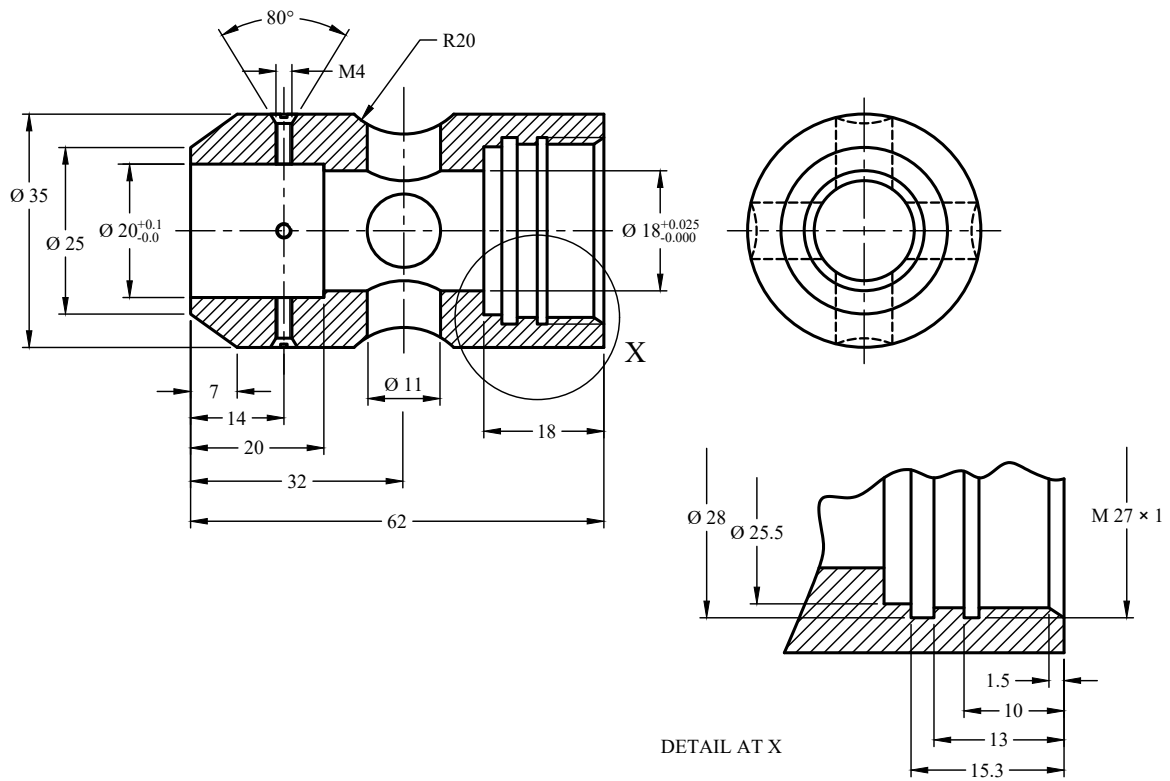

FIG. 8C NOZZLE HOUSING LAYOUT

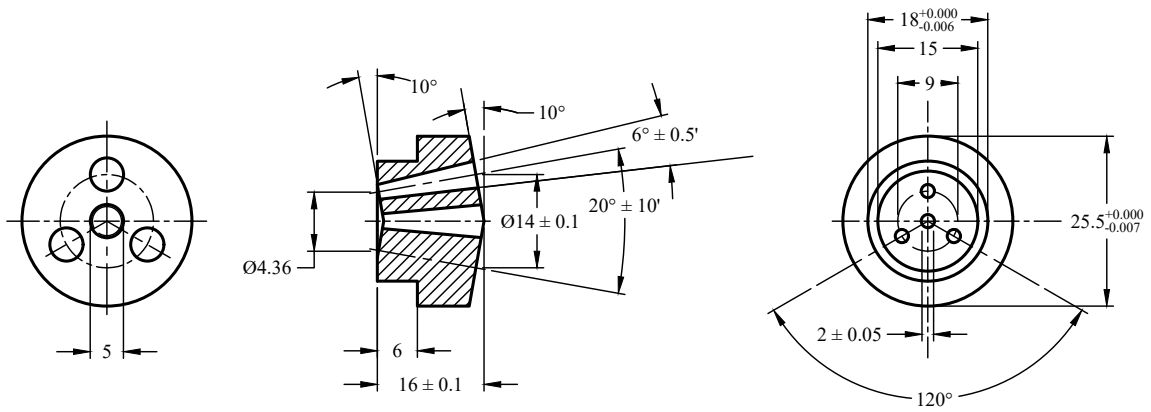

FIG. 8D INTERMEDIATE HEAD CONFIGURATION

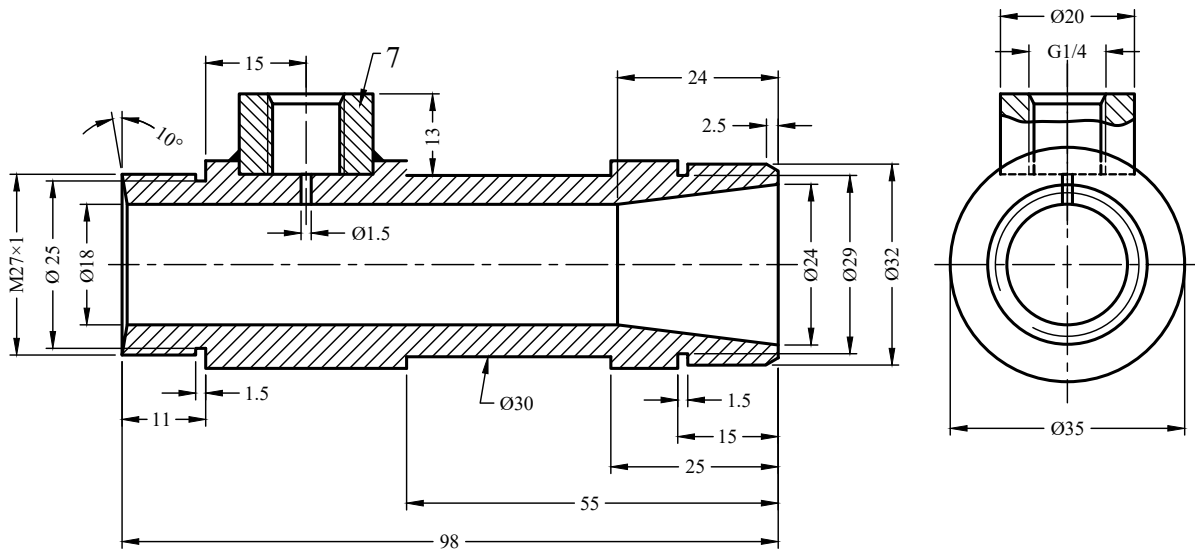

FIG. 8E CONNECTOR ASSEMBLY

All dimensions are in millimetres.

FIG. 8 NOZZLE<sup>2</sup>.

(Page 19, Annex N) — Substitute 'Annex P' for 'Annex N'.