विकिरण संरक्षण के लिए रेफरेंस विकिरण
क्षेत्र — परिभाषाएँ और मूल सिद्धान्त

Reference Radiation Fields for
Radiation Protection — Definitions
and Fundamental Concepts

ICS 13.280

© BIS 2023
© ISO 2012



भारतीय मानक ब्यूरो
BUREAU OF INDIAN STANDARDS
मानक भवन, 9 बहादुर शाह ज़फर मार्ग, नई दिल्ली - 110002
MANAK BHAVAN, 9 BAHADUR SHAH ZAFAR MARG
NEW DELHI - 110002

www.bis.gov.in www.standardsbis.in

NATIONAL FOREWORD

This Indian Standard which is identical with ISO 29661 : 2012 'Reference radiation fields for radiation protection — Definitions and fundamental concepts' issued by the International Organization for Standardization (ISO) was adopted by the Bureau of Indian Standards on the recommendation of the Nuclear Energy for Peaceful Applications Sectional Committee and approval of the Chemical Division Council.

This standard defines terms and fundamental concepts for the calibration of dosimeters and equipment used for the radiation protection dosimetry of external radiation — in particular, for beta, neutron, and photon radiation. It defines the measurement quantities for radiation protection dosimeters and doserate meters and gives recommendations for establishing these quantities. For individual monitoring, it covers whole body and extremity dosimeters (including those for the skin and the eye lens), and for area monitoring, portable and installed dosimeters. Guidelines are given for the calibration of dosimeters and doserate meters used for individual and area monitoring in reference radiation fields. Recommendations are made for the position of the reference point and the phantom to be used for personal dosimeters. This standard also deals with the determination of the response as a function of radiation quality and angle of radiation incidence.

The text of ISO Standard has been approved as suitable for publication as an Indian Standard without deviations. Certain conventions and terminologies are, however, not identical to those used in Indian Standards. Attention is particularly drawn to the following:

- a) Wherever the words 'International Standard' appear referring to this standard, they should be read as 'Indian Standard'; and
- b) Comma (,) has been used as a decimal marker in the International Standard, while in Indian Standards, the current practice is to use a point (.) as the decimal marker.

In this adopted standard, the reference appears to certain International Standards for which Indian Standards also exist. The corresponding Indian Standards, which are to be substituted in their respective places, are listed below along with their degree of equivalence for the editions indicated:

<i>International Standards</i>	<i>Corresponding Indian Standard</i>	<i>Degree of Equivalence</i>
ISO/IEC 17025 General requirements for the competence of testing and calibration laboratories.	IS/ISO/IEC 17025 : 2017 General requirements for the competence of testing and calibration laboratories (<i>second revision</i>)	Identical with ISO/IEC 17025 : 2017

The technical committee has reviewed the provisions of the following International Standards referred in this adopted standard and has decided that they are acceptable for use in conjunction with this standard:

<i>International Standards</i>	<i>Title</i>
ISO/IEC Guide 98-3	Uncertainty of measurement — Part 3: Guide to the expression of uncertainty in measurement (GUM: 1995)

In this adopted standard, reference appears to certain International Standards/documents where the standard atmospheric conditions to be observed are stipulated which are not applicable to tropical/subtropical countries. The applicable standard atmospheric conditions for Indian conditions are $(27 \pm 2) ^\circ\text{C}$ and (65 ± 5) percent relative humidity and shall be observed while using this standard.

In reporting the result of a test or analysis made in accordance with this standard, if the final value, observed or calculated, is to be rounded off, it shall be done in accordance with IS 2 : 2022 'Rules for rounding off numerical values (*second revision*)'.

Contents

Page

Introduction	iv
1 Scope	1
2 Normative references	1
3 Terms and definitions	1
3.1 General	1
3.2 Quantities and conversion coefficients	9
4 Symbols	15
5 Application of the measurement quantities and units	17
5.1 Measurement quantities for area monitoring	17
5.2 Measurement quantities for individual monitoring	18
5.3 Establishing of the measurement quantities for area and individual monitoring	18
6 Calibration and determination of the response in reference radiation fields	18
6.1 General principles	18
6.2 Calibration in reference radiation fields	19
6.3 Determination of the response in reference radiation fields	21
6.4 Methods for the determination of the calibration coefficient	22
6.5 Special considerations for area dosimeters (area survey meters)	25
6.6 Special considerations for personal dosimeters	26
7 Uncertainty	29
8 Certificates	29
Annex A (normative) List of reference conditions and standard test conditions	30
Annex B (normative) Description of the calibration coefficient	31
Bibliography	33

Introduction

International Standards ISO 4037, ISO 6980, ISO 8529 and ISO 12789^{[1]...[12]}, with focus on photon, beta and neutron reference radiation fields, are each divided into several parts: one part gives the methods of production and characterization of reference radiation fields, and others describe the dosimetry of the reference radiation qualities and the procedures for calibrating and determining the response of dosimeters and doserate meters in terms of the operational quantities of the International Commission on Radiation Units and Measurements (ICRU)^{[25] [26] [27] [28] [31]}.

The subject of these four International Standards is the same; they differ only in the kind of radiation each addresses. Their terms and definitions, and most of the descriptions of methods and procedures given are basically the same — whatever the radiation. Nevertheless, they do differ, more or less, from one to the other in detail. This International Standard brings together terms and definitions and fundamental concepts common to all of them. Thus, it serves to harmonize International Standards on radiation protection.

Besides definitions relating to calibration primary quantities, the operational quantities for area and individual monitoring are specified. For area monitoring, the operational quantities are ambient dose equivalent, $H^*(10)$, directional dose equivalents, $H'(0,07,\vec{\Omega})$ and $H'(3,\vec{\Omega})$, and the appropriate dose rates. For individual monitoring using personal dosimeters, the dose equivalent quantities, $H_p(10)$, $H_p(0,07)$ and $H_p(3)$, and the respective dose rates are available.

The method used to represent these operational quantities is the following. First, a basic (primary) quantity, such as air kerma free-in-air, fluence or absorbed dose to soft tissue, is measured. Then the appropriate operational quantity is derived by the application of the conversion coefficient that relates the basic (primary) quantity to the selected operational quantity. The procedure for the calibration and the determination of the response of radiation protection dosimeters is described in general terms. Depending on the type of dosimeter under test, the position of the reference point is specified differently and the irradiation is either carried out on a phantom (for personal dosimeters) or free in air (for area dosimeters or area survey meters).

With the publication of this International Standard, it is intended that ISO 4037, ISO 6980, ISO 8529 and ISO 12789 be revised successively for further harmonization since, among other aspects, certain of their definitions differ from those published here and the symbols chosen for this International Standard are more consistent with ICRU reports and other International Standards used for radiation protection purposes.

Indian Standard

REFERENCE RADIATION FIELDS FOR RADIATION PROTECTION — DEFINITIONS AND FUNDAMENTAL CONCEPTS

1 Scope

This International Standard defines terms and fundamental concepts for the calibration of dosimeters and equipment used for the radiation protection dosimetry of external radiation — in particular, for beta, neutron and photon radiation. It defines the measurement quantities for radiation protection dosimeters and doserate meters and gives recommendations for establishing these quantities. For individual monitoring, it covers whole body and extremity dosimeters (including those for the skin and the eye lens), and for area monitoring, portable and installed dosimeters. Guidelines are given for the calibration of dosimeters and doserate meters used for individual and area monitoring in reference radiation fields. Recommendations are made for the position of the reference point and the phantom to be used for personal dosimeters.

This International Standard also deals with the determination of the response as a function of radiation quality and angle of radiation incidence.

It is intended to be used by calibration laboratories and manufacturers.

2 Normative references

The following referenced documents are indispensable for the application of this document. For dated references, only the edition cited applies. For undated references, the latest edition of the referenced document (including any amendments) applies.

ISO/IEC Guide 98-3:2008, *Uncertainty of measurement — Part 3: Guide to the expression of uncertainty in measurement (GUM:1995)*

ISO/IEC 17025:2005, *General requirements for the competence of testing and calibration laboratories*. Corrected by ISO/IEC 17025:2005/Cor 1:2006

3 Terms and definitions

For the purposes of this document, the following terms and definitions apply.

NOTE These terms and definitions are relevant for the calibration of dosimeters and for the quantities and conversion coefficients that are general to ISO 4037, ISO 6980, ISO 8529 and ISO 12789. Special terms and definitions can be found in those International Standards.

3.1 General

3.1.1

angle of radiation incidence

α

angle, in the coordinate system of the dosimeter, between the direction of radiation incidence and the reference direction of the dosimeter in unidirectional fields

3.1.2

area dosimeter

area survey meter

meter designed to measure the ambient dose equivalent (rate) or the directional dose equivalent (rate)

[SOURCE: IEC 394-22-08, modified.]

3.1.3

background indication

indication obtained from a phenomenon, body or substance similar to the one under investigation, but for which a quantity of interest is supposed not to be present, or is not contributing to the indication

[SOURCE: ISO/IEC Guide 99:2007, 4.2.]

3.1.4

calibration

operation that, under specified conditions, in a first step, establishes a relation between the quantity values with measurement uncertainties provided by measurement standards and the corresponding indications with associated measurement uncertainties and, in a second step, uses this information to establish a relation for obtaining a measurement result from an indication

[SOURCE: ISO/IEC Guide 99:2007, 2.39.]

Note 1 to entry: A calibration may be expressed by a statement, calibration function, calibration diagram, calibration curve, or calibration table. In some cases, it may consist of an additive or multiplicative correction of the indication with associated measurement uncertainty.

Note 2 to entry: The measurement standard can be a primary standard, a secondary standard or a working measurement standard.

Note 3 to entry: Often the first step alone in the above definition is perceived as being calibration.

3.1.5

calibration coefficient

$N(U, \alpha)$

quotient of the conventional quantity value to be measured and the corrected indication of the dosimeter normalized to reference conditions

Note 1 to entry: The calibration coefficient $N(U, \alpha)$ for the reference radiation quality U and the angle of incidence α is equivalent to the calibration factor multiplied by the instrument coefficient (see Annex B). It is given by

$$N(U, \alpha) = \frac{H_o}{G_{\text{corr}}} = C_f(U, \alpha) \cdot c_i \quad (1)$$

where

H_o is the conventional quantity value;

G_{corr} is the corrected indication;

$C_f(U, \alpha)$ is the calibration factor for the radiation quality U and the angle of incidence α ; and

c_i is the instrument constant.

Concerning the dimension of the calibration factor and the calibration coefficient, see the Notes to 3.1.7 and 3.1.17.

Note 2 to entry: The reciprocal of the calibration coefficient is the response under reference conditions. The value of the calibration factor may vary with the magnitude of the quantity to be measured. In such cases a dosimeter is said to have a non-constant response (or a nonlinear indication).

Note 3 to entry: To distinguish between the indication of the standard and the dosimeter, subscripts 's' and 'd' are used and the respective coefficients are named $N(U, \alpha)_s$ and $N(U, \alpha)_d$.

[SOURCE: ICRU Report 76 modified.]

3.1.6

calibration conditions

conditions within the range of standard test conditions actually prevailing during the calibration measurement

**3.1.7
calibration factor**

$C_f(U, \alpha)$

factor by which the product of the corrected indication, G_{corr} , and the associated instrument constant, c_i , of the dosimeter is multiplied to obtain the conventional quantity value to be measured under reference conditions

Note to entry: The calibration factor is dimensionless.

[SOURCE: ICRU Report 76, modified.]

**3.1.8
conventional quantity value**

H_0

quantity value attributed by agreement to a quantity for a given purpose

Note to entry: The conventional quantity value H_0 is the best estimate of the quantity to be measured, determined by a primary standard or a secondary or working measurement standard which are traceable to a primary standard.

[SOURCE: ISO/IEC Guide 99:2007, 2.39.]

**3.1.9
correction factor**

k

numerical value by which the indication is multiplied to compensate for the deviation of measurement conditions from reference conditions or for a systematic effect (e.g. ion recombination)

Note to entry: If the correction of the effect of an influence quantity requires a multiplicative factor, the influence quantity is of type F, see Note to entry 1 for 3.1.16.

**3.1.10
correction factor for non-constant response**

k_n

numerical value by which the indication is multiplied to compensate for the non-constant response (or non-linear indication) of the dosimeter, i.e. for the variation of the calibration factor or calibration coefficient with the variation of the magnitude of the quantity to be measured

Note to entry: For a dosimeter with constant response with respect to the selected measuring quantity, k_n is equal to unity.

**3.1.11
corrected indication**

G_{corr}

indication of a dosimeter corrected for any differences of the values of the influence quantities from reference conditions

Note 1 to entry: The corrected indication, G_{corr} , can be calculated with the correction factor, k_n , for non-constant response, the q correction factors, k_f , for the influence quantities of type F and the p correction summands, G_w , for the influence quantities of type S. It is given by

$$G_{\text{corr}} = k_n \cdot \left(G - \sum_{w=1}^p G_w \right) \cdot \prod_{f=1}^q k_f \quad (2)$$

which is a model function of the measurement necessary for any determination of the uncertainty according to ISO/IEC Guide 98-3.

Note 2 to entry: To distinguish between the indication of the standard and the dosimeter, Subscripts 's' and 'd' are used and the respective indications are named $G_{s,\text{corr}}$ and $G_{d,\text{corr}}$.

3.1.12
correction summand

G_w
value added to the indication to compensate the deviation of measurement conditions from reference conditions or for a systematic error (e.g. zero indication)

Note to entry: If the correction of the effect of an influence quantity requires a summand, the influence quantity is of type S, see Note 1 to entry 3.1.16.

3.1.13
ICRU tissue

material equivalent to the human soft tissue with a density of $1 \text{ g}\cdot\text{cm}^{-3}$ and a mass composition of 76,2 % oxygen, 11,1 % carbon, 10,1 % hydrogen and 2,6 % nitrogen

[SOURCE: ICRU Report 33.]

3.1.14
ICRU sphere

spherical phantom of 30 cm in diameter made of ICRU tissue

Note to entry: This phantom is only used for the calculation of conversion coefficients to ambient or directional dose equivalent and not for dosimeter calibration.

[SOURCE: ICRU Report 33, modified.]

3.1.15
indication

G
quantity value provided by a measuring instrument or a measuring system

Note 1 to entry: A measuring instrument or a measuring system may consist of several parts, e.g. the ionisation chamber plus the electrometer, or the complete instrument in one housing, but always without the phantom (if used). In this International Standard it is always termed a *dosemeter*.

Note 2 to entry: The units of the indication of the dosimeter are not necessarily the same as that of the measurand. For example, for measurements with ionisation chambers the instrument indication is, in general, the value of the current I or of the charge Q . It is necessary to document whether the indication is normalized to the reference conditions to account for influence quantities and is corrected for intrinsic background and other influences. The corrected indication is named G_{corr} .

Note 3 to entry: To distinguish between the indication of the standard and the dosimeter, subscripts 's' and 'd' are used and the respective indications are named G_s and G_d .

[SOURCE: ISO/IEC Guide 99:2007, 4.1.]

3.1.16
influence quantity

quantity that, in a direct measurement, does not affect the quantity that is actually measured, but affects the relation between the indication and the measurement result

Note 1 to entry: The correction of the effect of the influence quantity can require a correction factor (influence quantity of type F) and/or a correction summand (influence quantity of type S) to be applied to the indication of the dosimeter, e.g. energy for type F and microphony or electromagnetic disturbance for type S, see 3.1.9 and 3.1.12.

Note 2 to entry: The dose rate is an influence quantity when measuring the dose.

[SOURCE: ISO/IEC Guide 99:2007, 2.52.]

3.1.17
instrument constant

c_i

constant by which the indication of the dosimeter, G , or — if corrections or a normalization were applied — the corrected indication, G_{corr} , is multiplied to convert it to the same unit as the measurand

Note to entry: If the instrument's indication is already expressed in the same unit as the measurand, c_i is unnecessary.

[SOURCE: ICRU Report 76.]

3.1.18
measurand

quantity intended to be measured

[SOURCE: ISO/IEC Guide 99:2007, 2.3.]

3.1.19
measured quantity value
measured value

M

quantity value representing a measurement result

Note to entry: See 6.2.4.

[SOURCE: ISO/IEC Guide 99:2007, 2.10.]

3.1.20
monitor device

device installed in an irradiation facility to monitor the fluence or dose (rate) of the irradiation field

3.1.21
personal dosimeter

meter designed to measure the personal dose equivalent (rate)

Note to entry: A personal dosimeter can be worn on the trunk (whole-body personal dosimeter), at the extremities (extremity personal dosimeter) or close to the eye lens (eye lens dosimeter).

[SOURCE: IEC 394-22-08, modified.]

3.1.22
phantom

artefact constructed to simulate the scattering properties of the human body or parts of the human body such as the extremities

Note to entry: A phantom can be used for the definition of a quantity and made of artificial material, e.g. ICRU tissue, or for the calibration and then be made of physically existing material, see 6.6.2 for details.

3.1.23
point of test

point in the radiation field at which the conventional quantity value is known

[SOURCE: ICRU Report 76.]

3.1.24
primary measurement standard
primary standard

measurement standard established using a primary reference measurement procedure, or created as an artefact, chosen by convention

EXAMPLE Free-air chambers as primary measurement standards of the measurand air kerma free-in-air.

Note 1 to entry: A primary standard has the highest metrological quality in a given field of metrology.

Note 2 to entry: The quantity value of the primary standard is equated to the best estimate of the quantity to be measured, i.e. the conventional quantity value.

[SOURCE: ISO/IEC Guide 99:2007, 5.4.]

3.1.25
quantity

property of a phenomenon, body or substance, where the property has a magnitude that can be expressed as a number and a reference

[SOURCE: ISO/IEC Guide 99:2007, 1.1.]

Note to entry: The quantities considered in the scope of this International Standard are the operational quantities for radiation protection purposes (ambient dose equivalent, directional dose equivalent, personal dose equivalent and the respective dose rates) and the basic quantities such as air kerma free-in-air, fluence and absorbed dose to soft tissue.

3.1.26
quantity value

number and reference together expressing magnitude of a quantity

EXAMPLE 1,52 $\mu\text{Gy h}^{-1}$ as the dose rate in a given radiation field.

Note to entry: A quantity value is a product of a number and a measurement unit (the unit one is generally not indicated for quantities of dimension one).

[SOURCE: ISO/IEC Guide 99:2007, 1.19.]

3.1.27
radiation detector

apparatus or substance used to convert incident ionizing radiation energy into a signal suitable for indication and/or measurement

[SOURCE: IEC 394-24-01.]

3.1.28
radiation quality

U
characteristic of ionizing radiation determined by the spectral distribution of radiation with respect to energy

Note to entry: The characteristic is expressed by parameters which are given together with their values in ISO 4037, ISO 6980, ISO 8529 and ISO 12789. Examples of the parameters are effective energy, half-value layer, X-ray tube voltage and filtration.

[SOURCE: IEC 881-02-22, modified.]

3.1.29
reference direction

direction, in the coordinate system of the dosimeter, with respect to which the angle of radiation incidence is measured in reference fields

Note 1 to entry: At the angle of incidence of 0° the reference direction of the dosimeter is parallel to the direction of radiation incidence. At the angle of 180° the reference direction of the dosimeter is anti-parallel to the direction of radiation incidence.

Note 2 to entry: The reference direction, in the coordinate system of the dosimeter, points into the dosimeter (see Figure 1). For parts to be irradiated consisting of a personal dosimeter and a cylindrical phantom such as a pillar or rod phantom the reference direction points into the phantom and is perpendicular to the centre line of the phantom.

3.1.30
reference operating condition
reference condition

operating condition prescribed for evaluating the performance of a measuring instrument or measuring system or for comparison of measurement results

[SOURCE: ISO/IEC Guide 99:2007, 4.11.]

3.1.31

reference orientation

orientation of the dosimeter for which the direction of the incident radiation coincides with the reference direction of the dosimeter

[SOURCE: ICRU Report 76.]

3.1.32

reference point

point of the dosimeter that is placed at the point of test for calibration and test purposes

Note 1 to entry: The distance of the measurement is given by the distance between the emission point of the radiation source and the reference point of the dosimeter.

Note 2 to entry: In the case of the calibration of a personal dosimeter, the phantom has to be included in the calibration process, see Figure 1 and 6.6.3.

[SOURCE: ICRU Report 76, modified.]

3.1.33

reference radiation field

radiation field whose radiation quality and dosimetric parameters have values according to International Standards or which is provided by the BIPM

Note 1 to entry: Examples of such International Standards are ISO 4037, ISO 6980, ISO 8529 and ISO 12789.

Note 2 to entry: In the upper part of Figure 1, the direction of the radiation incidence and the reference direction are parallel, i.e. the angle of incidence is $\alpha = 0^\circ$. In the lower part of Figure 1, the direction of radiation incidence and the reference direction have an angle of incidence of $\alpha = 45^\circ$.

3.1.34

response

R

quotient of the indication, G , or of the corrected indication, G_{corr} , and the conventional quantity value to be measured

Note 1 to entry: The full specification of the response includes specification of whether it is determined from G or G_{corr} and a statement of the measuring quantity. Examples are the response of the corrected indication with respect to fluence, R_ϕ , the response of the non-corrected indication with respect to kerma, R_K , and the response of the corrected indication with respect to the absorbed dose, R_D .

Note 2 to entry: The reciprocal of the response at reference conditions is equal to the calibration coefficient.

Note 3 to entry: The value of the response may vary with the magnitude of the quantity to be measured (dose or dose rate). In such cases the response is said to be non-constant (or the indication is nonlinear).

Note 4 to entry: The response usually varies with the energy and directional distribution of the incident radiation. Therefore, it may be useful to give the response as table of single values or diagram or curve or function $R(\bar{E}, \bar{\Omega})$ of the mean radiation energy \bar{E} of the radiation quality U and the direction $\bar{\Omega}$ of the incident monodirectional radiation. $R(\bar{E})$ describes the "energy dependence" and $R(\bar{\Omega})$ the "angular dependence" of the response; for the latter $\bar{\Omega}$ may be expressed by the angle, α , between the reference direction of the dosimeter and the direction of an external monodirectional field.

Note 5 to entry: For the determination of the energy dependence the most accurate information is obtained experimentally if small spectra are used, e.g. for X-rays the radiation qualities of the N series as described in ISO 4037-1.

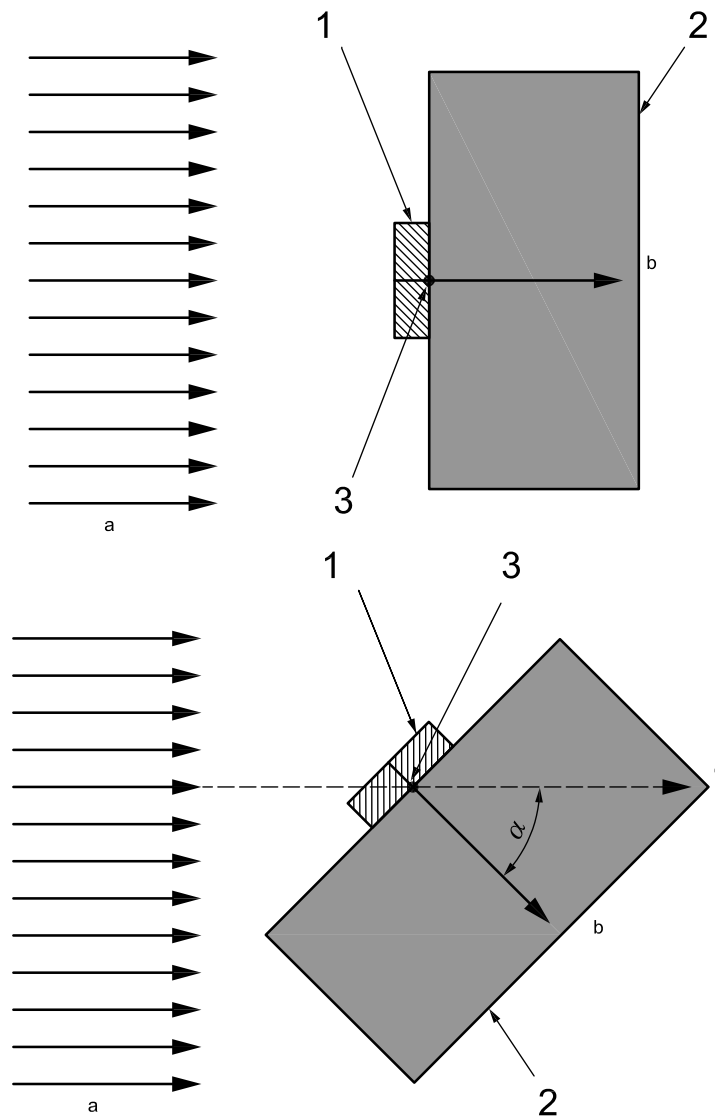

Key

- 1 personal dosimeter
- 2 water slab phantom
- 3 reference point
- a Direction of radiation incidence.
- b Reference direction.
- c Radiation incidence.

Figure 1 — Reference direction and direction of radiation incidence of personal dosimeter mounted on water slab phantom [see 6.6.2 a)]

**3.1.35
 secondary measurement standard
 secondary standard**

measurement standard established through calibration with respect to a primary measurement standard for a quantity of the same kind

Note 1 to entry: Calibration may be obtained directly between a primary measurement standard and a secondary measurement standard, or involve an intermediate measuring system calibrated by the primary measurement standard and assigning a measurement result to the secondary measurement standard.

Note 2 to entry: A secondary standard can be represented variously, e.g. as a measuring device or a radionuclide source unit.

Note 3 to entry: The calibration of the secondary standard is only valid for the irradiation conditions used, e.g. energy, dose and/or dose rate, environmental conditions.

Note 4 to entry: The quantity value of the secondary standard is equated to the best estimate of the quantity to be measured, i.e. the conventional quantity value.

[SOURCE: ISO/IEC Guide 99:2007, 5.5.]

3.1.36 standard test conditions

conditions represented by the range of values for the influence quantities under which a calibration or determination of the response is carried out

Note 1 to entry: Appropriate corrections to reference conditions should be made.

Note 2 to entry: Ideally, calibrations should be carried out under reference conditions. As this is not always achievable (e.g. for ambient air pressure) or convenient (e.g. for ambient temperature) a (small) interval around the reference values is acceptable. Values for the standard test conditions together with the reference conditions are given in Table A.1.

[SOURCE: ICRU Report 76 modified.]

3.1.37 true quantity value

quantity value consistent with the definition of a quantity

Note to entry: In the error approach to describing measurement, a true quantity value is considered unique and, in practice, unknowable. The uncertainty approach is to recognize that, owing to the inherently incomplete amount of detail in the definition of a quantity, there is not a single true quantity value but rather a set of true quantity values consistent with the definition. However, this set of values is, in principle and in practice, unknowable. Other approaches dispense altogether with the concept of true quantity value and rely on the concept of metrological compatibility of measurement results for assessing their validity.

[SOURCE: ISO/IEC Guide 99:2007, 2.11.]

3.1.38 working measurement standard

measurement standard that is used routinely to calibrate or verify measuring instruments or measuring systems

Note to entry: According to ISO/IEC Guide 99:2007, a working measurement standard is always traceable to a primary standard.

[SOURCE: ISO/IEC Guide 99:2007, 5.7.]

3.2 Quantities and conversion coefficients

3.2.1 absorbed dose

D

quotient of $d\bar{E}$ by dm , where $d\bar{E}$ is the mean energy imparted to matter of mass dm , thus

$$D = \frac{d\bar{E}}{dm}$$

Note 1 to entry: The SI unit of the absorbed dose is joules per kilogram ($\text{J}\cdot\text{kg}^{-1}$), known as grays (Gy).

Note 2 to entry: The full specification of the absorbed dose includes the specification of the material, e.g. soft tissue or air.

Note 3 to entry: The absorbed dose rate \dot{D} is the quotient of dD by dt , where dD is the increment of the absorbed dose in time interval dt . The unit is grays per second ($\text{Gy}\cdot\text{s}^{-1}$). Other units are any quotient of the gray or its decimal multiples and a suitable unit of time (e.g. $\text{mGy}\cdot\text{h}^{-1}$).

[SOURCE: ICRU Report 60.]

3.2.2 absorbed-dose-to-dose-equivalent conversion coefficient

h_D
quotient of the dose equivalent, H , and the absorbed dose, D

$$h_D = \frac{H}{D}$$

Note 1 to entry: The unit of the absorbed-dose-to-dose-equivalent conversion coefficient is sieverts per gray ($\text{Sv}\cdot\text{Gy}^{-1}$).

Note 2 to entry: The full specification of the absorbed-dose-to-dose-equivalent conversion coefficient includes the specification of the radiation to which it refers and of the type of dose equivalent (ambient, directional or personal), as well as for the absorbed dose the material, e.g. air or soft tissue. The absorbed-dose-to-dose-equivalent conversion coefficient h_D depends on the energy and, for $H_p(10)$, $H_p(3)$, $H_p(0,07)$, $H'(3;\vec{\Omega})$ and $H'(0,07;\vec{\Omega})$, also on the directional distribution of the incident radiation. Therefore, it is useful to consider the conversion coefficient as a function, $h_D(E, \alpha)$, of the energy, E , of monoenergetic particles at several angles of incidence α .

Note 3 to entry: The conversion coefficients from D to $H'(0,07;\vec{\Omega})$, to $H'(3;\vec{\Omega})$, to $H^*(10)$, to $H_p(10)$, to $H_p(3)$ or to $H_p(0,07)$ for the radiation quality U and the angle of incidence α , are indicated as $h'_D(0,07;U, \alpha)$, $h'_D(3;U, \alpha)$, $h^*_D(10;U)$, $h_{pD}(10;U, \alpha)$, $h_{pD}(3;U, \alpha)$, and $h_{pD}(0,07;U, \alpha)$, respectively.

3.2.3 total air kerma free-in-air

K_a
quotient of dE_{tr} by dm , where dE_{tr} is the sum of the initial kinetic energies of all the charged particles liberated by uncharged particles in a mass, dm , of air at a point of interest in air

$$K_a = \frac{dE_{tr}}{dm}$$

Note 1 to entry: The SI unit of air kerma is joules per kilogram ($\text{J}\cdot\text{kg}^{-1}$), known as grays (Gy).

Note 2 to entry: The air kerma rate, \dot{K}_a , is a quotient of dK_a by dt , where dK_a the increment of the air kerma in time interval dt . The unit is grays per second ($\text{Gy}\cdot\text{s}^{-1}$). Other units are any quotient of the gray or its decimal multiples and a suitable unit of time (e.g. $\text{mGy}\cdot\text{h}^{-1}$).

Note 3 to entry: The definition given specifies the total air kerma. It is given by the sum of the collision air kerma, $K_{a,\text{coll}}$, and the radiative air kerma, $K_{a,\text{rad}}$: $K_a = K_{a,\text{coll}} + K_{a,\text{rad}}$. The collision air kerma is the part of the air kerma that leads to the production of electrons through Compton scattering, photoelectric effect and pair production that dissipate their energy as ionization in or near the electron tracks in the medium. The radiative air kerma is the part of the air kerma that leads to the production of third-generation photons as the secondary charged particles are decelerated in the medium. The third-generation photons are produced via a) bremsstrahlung emission, b) positron annihilation in flight, c) fluorescence emission as a result of electron- and positron-impact ionization, and d) the effects on these processes of energy-loss straggling and knock-on electron production. This scheme goes beyond that of ICRU 33, which formally includes only a). See Reference [37] for details.

[SOURCE: ICRU 60, modified.]

3.2.4 air kerma-to-dose-equivalent conversion coefficient

h_K
quotient of the dose equivalent, H , and the collision air kerma free-in-air, $K_{a,\text{coll}}$, at a point in the photon radiation field

$$h_K = \frac{H}{K_{a,\text{coll}}}$$

Note 1 to entry: The unit of the air kerma-to-dose-equivalent conversion coefficient is sieverts per gray ($\text{Sv}\cdot\text{Gy}^{-1}$).

Note 2 to entry: The collision air kerma is the part of the air kerma that leads to the production of electrons that dissipate their energy as ionization in or near the electron tracks in the medium. Therefore, this collision air kerma was always meant in the definition of the conversion coefficient, although not precisely specified. See Reference [37] for details.

Note 3 to entry: The collision air kerma, $K_{a, \text{coll}}$, is related to the total air kerma by the factor g : $K_{a, \text{coll}} = K_a \cdot (1-g)$. Factor g is the fraction of the energy of the secondary electrons liberated by photons that is lost by radiative processes (bremsstrahlung, fluorescence radiation or annihilation radiation of positrons). For water or air and for energies lower than 1,3 MeV, g is less than 0,003.

Note 4 to entry: The full specification of an air kerma-to-dose-equivalent conversion coefficient includes the specification of the type of dose equivalent, e.g. ambient, directional or personal. The conversion coefficient, h_K , depends on the energy and, for $H_p(10)$, $H_p(3)$, $H_p(0,07)$, $H'(3; \vec{\Omega})$ and $H'(0,07; \vec{\Omega})$, also on the directional distribution of the incident radiation. It is, therefore, useful to consider the conversion coefficient as a function, $h_K(E, \alpha)$, of the energy, E , of monoenergetic photons at several angles of incidence α .

Note 5 to entry: The conversion coefficients from the air kerma free-in-air, K_a , to $H'(0,07)$, to $H'(3)$, to $H^*(10)$, to $H_p(10)$, to $H_p(3)$ or to $H_p(0,07)$ for the radiation quality U and the angle of incidence α are indicated as $h'_K(0,07; U, \alpha)$, $h'_K(3; U, \alpha)$, $h_K^*(10; U)$, $h_{pK}(10; U, \alpha)$, $h_{pK}(3; U, \alpha)$, and $h_{pK}(0,07; U, \alpha)$, respectively.

3.2.5 ambient dose equivalent

$H^*(d)$

dose equivalent at a point in a radiation field that would be produced by the corresponding expanded and aligned field, in the ICRU sphere at a depth, d , on the radius opposing the direction of the aligned field

Note 1 to entry: The SI unit of the ambient dose equivalent is joules per kilogram (J·kg⁻¹), known as sieverts (Sv).

Note 2 to entry: In the expanded and aligned field, the fluence and its energy distribution have the same values throughout the volume of interest as in the actual field at the point of test; the field is unidirectional.

Note 3 to entry: The full specification of the ambient dose equivalent includes the specification of the reference depth, d , expressed in millimetres.

Note 4 to entry: The ambient dose equivalent rate, $\dot{H}^*(d)$, is the quotient of $dH^*(d)$ by dt , where $dH^*(d)$ is the increment of the ambient dose equivalent at a depth, d , in time interval dt . The unit is sieverts per second (Sv·s⁻¹). Other units are any quotient of the sievert or its decimal multiples and a suitable unit of time (e.g. mSv·h⁻¹).

[SOURCE: ICRU Report 51, modified.]

3.2.6 directional dose equivalent

$H'(0,07; \vec{\Omega})$

dose equivalent at a point in a radiation field that would be produced by the corresponding expanded field, in the ICRU sphere at a depth, d , on a radius in a specified direction, $\vec{\Omega}$

Note 1 to entry: The SI unit of the directional dose equivalent is joules per kilogram (J·kg⁻¹), known as sieverts (Sv).

Note 2 to entry: In a unidirectional field, the direction can be specified in terms of the angle, α , between the radius opposing the incident field and a specified radius. For $\alpha = 0^\circ$, the quantity $H'(d; 0^\circ)$ may be written as $H'(d)$.

Note 3 to entry: In the expanded field, the fluence and its angular and energy distributions have the same values throughout the volume of interest as in the actual field at the point of test.

Note 4 to entry: The full specification of the directional dose equivalent includes the specification of the reference depth, d , expressed in millimetres.

Note 5 to entry: The directional dose equivalent rate, $\dot{H}'(d)$, is the quotient of $dH'(d)$ by dt , where $dH'(d)$ is the increment of the directional dose equivalent at a depth, d , in time interval dt . The unit is sieverts per second (Sv·s⁻¹). Other units are any quotient of the sievert or its decimal multiples and a suitable unit of time (e.g. mSv·h⁻¹).

[SOURCE: ICRU Report 51, modified.]

3.2.7 dose equivalent

H

product of Q and D at a point in tissue, where D is the absorbed dose and Q is the quality factor at that point, thus

$$H = Q \cdot D$$

Note 1 to entry: The SI unit of the dose equivalent is joules per kilogram ($\text{J}\cdot\text{kg}^{-1}$), known as sieverts (Sv).

Note 2 to entry: The dose equivalent rate \dot{H} is the quotient of dH by dt , where dH is the increment of the dose equivalent in time interval dt . The unit is sieverts per second ($\text{Sv}\cdot\text{s}^{-1}$). Other units are any quotient of the sievert or its decimal multiples and a suitable unit of time (e.g. $\text{mSv}\cdot\text{h}^{-1}$).

[SOURCE: ICRU 51.]

3.2.8 effective dose

E

result of the summation of the equivalent doses in tissues or organs, each multiplied by the appropriate tissue weighting factor, given by the expression

$$E = \sum_T w_T \cdot H_T$$

where H_T is the equivalent dose in tissue or organ, T , and w_T is the tissue weighting factor for tissue, T , and the effective dose can also be expressed as the sum of the doubly weighted absorbed dose in all the tissues and organs of the body

[SOURCE: ICRU Report 57.]

Note to entry: In this International Standard, the symbol E is used for the effective dose in order to distinguish it from energy, for which E is the common symbol.

3.2.9 energy and direction distribution of the fluence energy and direction distribution of the particle fluence energy distribution of particle radiance

$\Phi_{E,\Omega}$

quotient of $d\Phi$ by dE and $d\Omega$, where $d\Phi$ is the fluence of particles with energy between E and $E + dE$ and propagating within a solid angle $d\Omega$ around a specified direction Ω , expressed as

$$\Phi_{E,\Omega} = \frac{d^2\Phi}{dE d\Omega}$$

Note 1 to entry: The SI unit of the energy and direction distribution of the (particle) fluence is $\text{m}^{-2}\cdot\text{J}^{-1}\cdot\text{sr}^{-1}$; a widely used unit is $\text{cm}^{-2}\cdot\text{MeV}^{-1}\cdot\text{sr}^{-1}$.

Note 2 to entry: The full specification of the fluence includes the specification of the kind of particles, e.g. neutrons, photons or betas.

Note 3 to entry: The energy and direction distribution of the (particle) fluence rate $\dot{\Phi}_{E,\Omega}$ is the quotient of $d\dot{\Phi}_{E,\Omega}$ by dt , where $d\dot{\Phi}_{E,\Omega}$ is the increment of the energy and direction distribution of the fluence in time interval dt . The unit is $\text{m}^{-2}\cdot\text{J}^{-1}\cdot\text{sr}^{-1}\cdot\text{s}^{-1}$; a widely used unit is $\text{cm}^{-2}\cdot\text{MeV}^{-1}\cdot\text{sr}^{-1}\cdot\text{s}^{-1}$.

3.2.10
energy distribution of the fluence
energy distribution of the particle fluence

Φ_E
quotient of $d\Phi$ by dE , where $d\Phi$ is the fluence of particles of energy between E and $E + dE$

$$\Phi_E = \frac{d\Phi}{dE}$$

Note 1 to entry: The unit of the energy distribution of the (particle) fluence is $\text{m}^{-2}\cdot\text{J}^{-1}$; a widely used unit is $\text{cm}^{-2}\cdot\text{MeV}^{-1}$.

Note 2 to entry: The full specification of the fluence includes the specification of the kind of particles, e.g. neutrons, photons or betas.

Note 3 to entry: The measurand energy distribution of the (particle) fluence is used generally in neutron dosimetry.

Note 4 to entry: The energy distribution of the (particle) fluence rate $\dot{\Phi}_E$ is the quotient of $d\Phi_E$ by dt , where $d\Phi_E$ is the increment of the energy distribution of the fluence in time interval dt . The unit is $(\text{m}^{-2}\cdot\text{J}^{-1}\cdot\text{s}^{-1})$; a widely used unit is $(\text{cm}^{-2}\cdot\text{MeV}^{-1}\cdot\text{s}^{-1})$.

3.2.11
equivalent dose

H_T
dose in a tissue or organ given by

$$H_T = \sum_R w_R \cdot D_{T,R}$$

where $D_{T,R}$ is the mean absorbed dose from radiation, R, in a tissue or organ, T, and w_R is the radiation weighting factor

Note to entry: Since w_R is dimensionless, the unit for the equivalent dose is the same as for the absorbed dose, J kg^{-1} , expressed as sieverts (Sv).

[SOURCE: ICRP Report 103.]

3.2.12
fluence
particle fluence

Φ
quotient of dN by da , where dN is the number of particles incident on a sphere of cross-sectional area da , thus

$$\Phi = \frac{dN}{da}$$

Note 1 to entry: The SI unit of the fluence is m^{-2} ; a widely used unit is cm^{-2} .

Note 2 to entry: The full specification of the fluence includes the specification of the kind of particles, e.g. neutrons, photons or betas.

Note 3 to entry: The fluence rate, $\dot{\Phi}$, is the quotient of $d\Phi$ by dt , where $d\Phi$ is the increment of the fluence in time interval dt . The unit is $(\text{m}^{-2}\cdot\text{s}^{-1})$; a widely used unit is $(\text{cm}^{-2}\cdot\text{s}^{-1})$.

[SOURCE: ICRU Report 60.]

3.2.13

fluence-to-dose-equivalent conversion coefficient particle fluence-to-dose-equivalent conversion coefficient

h_{Φ}
quotient of the dose equivalent, H , and the (particle) fluence, Φ , at a point of test in the radiation field, undisturbed by the irradiated object

$$h_{\Phi} = \frac{H}{\Phi}$$

Note 1 to entry: The full specification of the fluence-to-dose-equivalent conversion coefficient includes the specification of the kind of particles, e.g. neutrons, photons or betas, and of the type of dose equivalent, e.g. ambient, directional or personal dose equivalent. The conversion coefficient h_{Φ} depends on the energy and, for $H_p(10)$, $H_p(3)$, $H'(3;\vec{\Omega})$ and $H'(0,07;\vec{\Omega})$, on the directional distribution of the incident radiation also.

Note 2 to entry: The SI unit of the (particle) fluence-to-dose-equivalent conversion coefficient is $\text{Sv}\cdot\text{m}^{-2}$; a frequently used unit is $\text{Sv}\cdot\text{cm}^{-2}$.

3.2.14

linear energy transfer linear collision stopping power

L
quotient of dE by dl , where dE is the mean energy lost by the charged particle due to collisions with electrons, in traversing a distance dl , thus

$$L = \frac{dE}{dl}$$

Note 1 to entry: The SI unit of the linear energy transfer is joules per metre ($\text{J}\cdot\text{m}^{-1}$), a widely used non-SI unit is $\text{keV}\cdot\mu\text{m}^{-1}$.

Note 2 to entry: L is sometimes termed the unrestricted linear energy transfer.

[SOURCE: ICRU Report 51, modified.]

3.2.15

personal dose equivalent

$H_p(d)$
dose equivalent in soft tissue, at an appropriate depth, d , below a specified point on the body

Note 1 to entry: The SI unit of the personal dose equivalent is joules per kilogram ($\text{J}\cdot\text{kg}^{-1}$), known as sieverts (Sv).

Note 2 to entry: The full specification of the personal dose equivalent includes the specification of the depth, d , expressed in millimetres.

Note 3 to entry: Soft tissue in this context is ICRU 4-element tissue with a density of $1\text{ g}\cdot\text{cm}^{-3}$, see 3.1.13.

Note 4 to entry: For the estimation of the local skin dose, a depth of 0,07 mm is employed. The personal dose equivalent for this depth is then denoted by $H_p(0,07)$. For the estimation of the effective dose, a depth of 10 mm is employed with analogous notation $H_p(10)$. For the lens of the eye, a depth of 3 mm is employed with analogous notation $H_p(3)$.

Note 5 to entry: In the ICRU Report 47 [27], ICRU has extended the definition of the personal dose equivalent to include the dose equivalent at a depth, d , in a phantom having the composition of the ICRU tissue. Then $H_p(d)$, for the calibration of personal dosimeters, is the dose equivalent at d in a phantom composed of ICRU tissue, but of the size and shape of the phantom used for the calibration (see 6.6.2).

Note 6 to entry: The personal dose equivalent rate $\dot{H}_p(d)$ is the dose equivalent rate in soft tissue below a specified point on the body at an appropriate depth, d . The unit is sievert per second ($\text{Sv}\cdot\text{s}^{-1}$). Other units are any quotient of the sievert or its decimal multiples and a suitable unit of time (e.g. $\text{mSv}\cdot\text{h}^{-1}$).

[SOURCE: ICRU Report 51.]

3.2.16 quality factor

Q

factor used to weight the absorbed dose D for biological effectiveness of the charged particles producing the absorbed dose

Note to entry: Q at a point in tissue is given by

$$Q = \frac{1}{D} \int_L Q(L) \cdot D_L dL$$

where D is the absorbed dose at that point, D_L is the distribution of D in linear energy transfer L , and $Q(L)$ is the corresponding quality factor at the point of interest. The integration is performed over D_L , due to all charged particles, excluding their secondary electrons.

[SOURCE: ICRU Report 51, modified.]

4 Symbols

The symbols used are given in Table 1.

Table 1 — Symbols

Symbol	Description	Unit
α	Angle of radiation incidence	degrees
$C_f(U, \alpha)$	Calibration factor for radiation quality U and angle of incidence α	—
c_i	Instrument constant	context-dependent ^a
D	Absorbed dose	Gy
\dot{D}	Absorbed dose rate	Gy·s ⁻¹
d	Depth in soft tissue; recommended depths: 10 mm, 3 mm, 0,07 mm	m
E	Energy	eV
E	Effective dose	Sv
f	Index of influence quantities of type F	—
Φ_E	Energy distribution of (particle) fluence	m ⁻² ·J ⁻¹
$\Phi_{E, \Omega}$	Energy and direction distribution of (particle) fluence	m ⁻² ·J ⁻¹ ·sr ⁻¹
Φ	Fluence (particle fluence)	m ⁻²
$\dot{\Phi}$	Fluence rate	m ⁻² ·s ⁻¹
G	Indication	context-dependent ^b
G_d	Indication of the dosimeter	context-dependent ^b
G_s	Indication of standard used to determine quantity value	context-dependent ^b
G_w	Correction summand number w due to zero indication or an influence quantity	context-dependent ^b
G_{corr}	Corrected indication	context-dependent ^b
$G_{d, \text{corr}}$	Corrected indication of dosimeter	context-dependent ^b
$G_{m, \text{corr}}$	Corrected indication of the monitor device at the measurement for the calibration of the dosimeter	context-dependent ^b
$G_{s, \text{corr}}$	Corrected indication of the standard used to determine quantity value	context-dependent ^b
$g_{m, \text{corr}}$	Corrected indication of monitor device at measurement for calibration of monitor device	context-dependent ^b

Table 1 (continued)

Symbol	Description	Unit
$g_{s,corr}$	Corrected indication of standard at measurement for calibration of monitor device	context-dependent ^b
H_0	Conventional quantity value	as measurand
H	Dose equivalent	Sv
H_T	Equivalent dose	Sv
\dot{H}	Dose equivalent rate	Sv·s ⁻¹
$H'(0,07,\bar{\Omega})$	Directional dose equivalent at depth 0,07 mm	Sv
$\dot{H}'(0,07,\bar{\Omega})$	Directional dose equivalent rate at depth 0,07 mm	Sv·s ⁻¹
$H_p(0,07)$	Personal dose equivalent at depth 0,07 mm	Sv
$\dot{H}_p(0,07)$	Personal dose equivalent rate at depth 0,07 mm	Sv·s ⁻¹
$H'(3,\bar{\Omega})$	Directional dose equivalent at depth 3 mm	Sv
$\dot{H}'(3,\bar{\Omega})$	Directional dose equivalent rate at depth 3 mm	Sv·s ⁻¹
$H_p(3)$	Personal dose equivalent at depth 3 mm	Sv
$\dot{H}_p(3)$	Personal dose equivalent rate at depth 3 mm	Sv·s ⁻¹
$H^*(10)$	Ambient dose equivalent at depth 10 mm	Sv
$\dot{H}^*(10)$	Ambient dose equivalent rate at depth 10 mm	Sv·s ⁻¹
$H_p(10)$	Personal dose equivalent at depth 10 mm	Sv
$\dot{H}_p(10)$	Personal dose equivalent rate at depth 10 mm	Sv·s ⁻¹
h_K	Air kerma-to-dose-equivalent conversion coefficient	Sv·Gy ⁻¹
$h_K(E, \alpha)$	Air kerma-to-dose-equivalent conversion coefficient, depending on energy E of mono-energetic particles at angle of incidence α	Sv·Gy ⁻¹
$h_K(U, \alpha)$	Air kerma-to-dose-equivalent conversion coefficient for radiation quality U and angle of incidence α	Sv·Gy ⁻¹
h_Φ	(Particle) fluence-to-dose-equivalent conversion coefficient	Sv·m ⁻²
h_D	Absorbed-dose-to-dose-equivalent conversion coefficient	Sv·Gy ⁻¹
$h_D(E, \alpha)$	Absorbed-dose-to-dose-equivalent conversion coefficient, depending on the energy E of mono-energetic particles at the angle of incidence α	Sv·Gy ⁻¹
$h_D(U, \alpha)$	Absorbed-dose-to-dose-equivalent conversion coefficient for the radiation quality U and the angle of incidence α	Sv·Gy ⁻¹
K_a	Total air kerma free-in-air	Gy
$K_{a,coll}$	Collision air kerma free-in-air	Gy
$K_{a,rad}$	Radiative air kerma free-in-air	Gy
$k(U, \alpha)$	Correction factor for radiation quality (or radiation energy distribution) U and angle of incidence α for determination of calibration coefficient or factor	—
k	Correction factor due to deviation of measurement conditions from reference conditions	—
k_f	Correction factor for influence quantity number f of type F	—
k_n	Correction factor for non-constant response	—

Table 1 (continued)

Symbol	Description	Unit
M	Measured value	as quantity
$N(U, \alpha)$	Calibration coefficient	context-dependent ^a
$N(U, \alpha)_d$	Calibration coefficient of dosimeter	context-dependent ^a
$N(U, \alpha)_m$	Calibration coefficient of monitor device	context-dependent ^a
$N(U, \alpha)_s$	Calibration coefficient of standard	context-dependent ^a
p	Number of influence quantities of type S	—
Q	Quality factor	—
q	Number of influence quantities of type F	—
R	Response	context-dependent
R_{ref}	Response under reference conditions	context-dependent
$R(U, \alpha)_G$	Response relating to indication G for radiation quality (or energy distribution) U and angle of incidence α	context-dependent
$R(U, \alpha)_{Gd}$	Response relating to indication G_d of dosimeter for radiation quality (or energy distribution) U and angle of incidence α	context-dependent
$R(U, \alpha)_{Gs}$	Response relating to indication G_s of standard for radiation quality (or energy distribution) U and angle of incidence α	context-dependent
$R(U, \alpha)_{G_{corr}}$	Response relating to corrected indication G_{corr} for radiation quality (or energy distribution) U and angle of incidence α	context-dependent
$R(U, \alpha)_{Gd, corr}$	Response relating to corrected indication $G_{d, corr}$ of dosimeter for radiation quality (or energy distribution) U and angle of incidence α	context-dependent
$R(U, \alpha)_{Gs, corr}$	Response relating to corrected indication $G_{s, corr}$ of standard for radiation quality (or energy distribution) U and angle of incidence α	context-dependent
R	Relative response	—
U	Radiation quality (radiation energy distribution), e.g. N-100	—
$\vec{\Omega}$	Specified direction	—
w	Index of influence quantities of type S	—
w_R	Radiation weighting factor	—
w_T	Tissue weighting factor	—

^a See Note to entry for 3.1.17.

^b See Note 2 to entry for 3.1.15.

5 Application of the measurement quantities and units

5.1 Measurement quantities for area monitoring

The measurement quantities for area monitoring are $H^*(10)$, $H'(0,07, \vec{\Omega})$ and $H'(3, \vec{\Omega})$. Frequently, for area dosimeters the measurement quantity is also the respective dose rate, i.e. the ambient dose equivalent rate, $\dot{H}^*(10)$, or the directional dose equivalent rate, $\dot{H}'(0,07, \vec{\Omega})$ or $\dot{H}'(3, \vec{\Omega})$.

NOTE 1 In practical radiation protection, the direction, $\vec{\Omega}$, is rarely used. Almost exclusively, the maximum values of $\dot{H}'(0,07, \vec{\Omega})$ and $H'(0,07, \vec{\Omega})$ or $\dot{H}'(3, \vec{\Omega})$ and $H'(3, \vec{\Omega})$, respectively, at the point of interest, are of importance, obtained by rotating the portable area dosimeter until the maximum indication occurs. These maximum values are often given in simplified terms as $H'(0,07)$ and $\dot{H}'(0,07)$, or as $H'(3)$ and $\dot{H}'(3)$, respectively.

NOTE 2 In general, calibrations are performed in nominally unidirectional fields. In these cases, the direction, $\vec{\Omega}$, can be specified in terms of the angle α between the direction of the incident radiation and the reference direction of the dosimeter. The measurement quantity is then denoted by $H'(0,07,\alpha)$ and $\dot{H}'(0,07,\alpha)$ or by $H'(3,\alpha)$ and $\dot{H}'(3,\alpha)$, respectively.

5.2 Measurement quantities for individual monitoring

The measurement quantities for individual monitoring are $H_p(10)$, $H_p(0,07)$ and $H_p(3)$. Frequently, active personal dosimeters can indicate, besides $H_p(10)$ and/or $H_p(0,07)$ and/or $H_p(3)$, the personal dose equivalent rate at 10 mm depth $\dot{H}_p(10)$ or/and the personal dose equivalent rate at 0,07 mm depth $\dot{H}_p(0,07)$ or/and the personal dose equivalent rate at 3 mm depth $\dot{H}_p(3)$, e.g. for purposes of alarming.

5.3 Establishing of the measurement quantities for area and individual monitoring

The radiation protection quantities (see 5.1 and 5.2) are linked by conversion coefficients to radiometric and dosimetric quantities characterizing the radiation field. In practice, the basic quantities that are usually used are

- in beta dosimetry, the absorbed dose, D , to tissue,
- in photon dosimetry, the collision air kerma free-in-air, $K_{a, \text{coll}}$, and
- in neutron dosimetry, the particle fluence, Φ .

The radiation protection (operational) quantity is obtained by multiplication of the basic quantity with the appropriate conversion coefficient.

The monoenergetic conversion coefficients for parallel (unidirectional), extended, monoenergetic beams of photons and neutrons were tabulated, for example, in ICRU Report 57 [29] and ICRP Report 74 [33]. Details of the calculation are given by ICRU Report 57 [29] [33] [19] [21] [22] [23]. These conversion coefficients for monoenergetic radiation shall be treated as having no uncertainty.

The conversion coefficients for photons and neutrons for a reference radiation quality can be calculated by an integration of the product of the energy distribution of the basic quantity of the field and the corresponding monoenergetic conversion coefficients (see Reference [16] for photon radiation). The uncertainty of the conversion coefficients for a given quality, as specified in the respective standard, can be reduced if they are determined individually from the evaluated or measured spectrum [4] [16].

The conversion coefficients for betas are in most cases 1 Sv Gy^{-1} , as the absorbed dose to tissue for a reference radiation quality is measured in the appropriate depth of 0,07 mm or 3 mm. Further details are given in ISO 6980.

Calibration measurements for photons shall be done with secondary charged particle equilibrium at the reference point of the dosimeter. If the thickness of the material in front of the reference point (e.g. air or parts of the dosimeter itself) is not sufficient to achieve secondary charged particle equilibrium, an additional poly(methyl methacrylate) (PMMA) layer shall be positioned in front of the dosimeter to secure completed build-up. Further details are given in ISO 4037.

6 Calibration and determination of the response in reference radiation fields

6.1 General principles

6.1.1 Parts to be irradiated

The parts to be irradiated in the radiation field are those of the dosimeter to be irradiated and possibly additional equipment, e.g. a phantom. They are considered as a unit for the purposes of calibration and determination of the response.

For an area dosimeter, the parts to be irradiated comprise at least the radiation detector and possibly additional equipment, e.g. an additional cover or cables. They do not include any phantom.

For a personal dosimeter, the parts to be irradiated comprise at least those of the personal dosimeter worn by the person and an appropriate phantom (see 6.6.2).

6.1.2 Conditions of the dosimeter under test

Before any calibration or determination of the response is made, the parts to be irradiated and all further parts of the dosimeter shall be examined to confirm that they are in a good working condition and free of radioactive contamination. The set-up procedure and the mode of operation of the dosimeter shall be in accordance with its instruction manual, as provided by the manufacturer.

6.1.3 Point of test and reference point

Measurements shall be carried out by positioning the reference point of the dosimeter at the point of test at which the conventional quantity value, H_0 , and its associated uncertainty are known; H_0 shall be traceable to a national or international primary standard.

The dosimeter shall be positioned in the radiation field at the point of test such that its reference direction is oriented in the required orientation. For an angle of incidence of $\alpha = 0^\circ$ (normal incidence), the dosimeter shall be positioned such that its reference direction is parallel to the direction of radiation incidence.

6.1.4 Axes of rotation

For calibrating a dosimeter at different angles of incidence, i.e. for examining the effect of the variation of the direction of radiation incidence on the dosimeter indication, a rotation of all the parts to be irradiated is required. The axis of rotation shall pass through the reference point of the dosimeter.

The dependence of the response on the direction of radiation incidence shall be determined by a rotation of all the parts to be irradiated around at least two axes being perpendicular to the reference direction. The direction of the axes shall be mutually perpendicular. The axes used shall be specified.

6.1.5 Reference conditions and standard test conditions for influence quantities

The calibration is intended to be carried out under reference conditions (see Table A.1). Frequently, it is not possible to keep all influence quantities (e.g. air pressure, humidity, temperature) at their reference values. Standard test conditions (see Table A.1) describe the range of acceptable variations of influence quantities when those quantities are not at reference values. The effect of the deviation of influence quantities away from reference values shall be corrected. If this is not possible, the effect of this difference shall be considered in the uncertainty statement. The determination of the response shall be performed under standard test conditions.

Depending on the way chosen for the presentation of the calibration results (see Annex B), either several sets of reference conditions differing by the radiation quality and angle of radiation incidence are defined or one single set of reference conditions, including one reference radiation quality and one reference angle of radiation incidence, is chosen and several correction factors are specified.

6.2 Calibration in reference radiation fields

6.2.1 Concept of calibration

The operation of the calibration of a dosimeter comprises of the following procedures.

- Firstly, the conventional quantity value of the dose equivalent H_0 and its uncertainty is determined in a given radiation field for a radiation quality, U , and an angle of radiation incidence, α , at the point of test, i.e. at a specified position in the radiation beam, see 6.2.2.
- Secondly, in the same radiation field, the dosimeter — or, more precisely, all the parts to be irradiated — are irradiated, and the indication, G_d , or the corrected indication, $G_{d,corr}$, of the dosimeter is determined together with its uncertainty.
- Thirdly, the calibration coefficient, $N(U, \alpha)_d$, for the quantity dose equivalent is calculated, see 6.2.3.

When using the dosimeter in an unknown radiation field, the measured value, M , of the dose equivalent determined with the dosimeter is calculated, see 6.2.4.

The conditions, e.g. dose, dose rate, the axis of rotation, for which the calibration coefficient is determined, should be specified in the scope of the calibration of the dosimeter.

NOTE Subscript 'd' refers to dosimeter.

6.2.2 Determination of the conventional quantity value from a secondary or a working standard

For the determination of the conventional quantity value of the dose equivalent, H_0 , the reference point of a measurement standard is positioned at the point of test. The measurement standard can be a secondary standard or a working measurement standard.

The conventional quantity value of H_0 at radiation quality U and angle of incidence α , determined by a secondary or working standard, is given by

$$H_0 = N(U, \alpha)_s \cdot G_{s, \text{corr}} \quad (3)$$

where

- H_0 is the conventional quantity value of the dose equivalent;
- $N(U, \alpha)_s$ is the value of the calibration coefficient given in the secondary or working standard for the quantity dose equivalent and for the radiation quality U and angle of radiation incidence α ;
- $G_{s, \text{corr}}$ is the corresponding indication of the standard, normalized to reference conditions and corrected for any other influences, where applicable.

NOTE Subscript 's' refers to standard (secondary or working standard).

At the time of measurement, the influence quantities and the parameters of the secondary or working standard may differ from its reference values. The influence of these deviations to the indication can be reduced with corrections and shall be considered in the associated uncertainty (see 3.1.11).

6.2.3 Determination of the corrected indicated value and the calibration coefficient

The indication of the dosimeter, G_d , is determined at the point of test. If, at the time of measurement, the influence quantities and the parameters of the parts to be irradiated, e.g. phantom, differ from its reference values, the influence of these deviations to the indication can be corrected. The corrected indication of the dosimeter, $G_{d, \text{corr}}$, i.e. the indication normalized to reference conditions and corrected for any other influences, where applicable, can be calculated with correction factor k_n for non-constant response, the q correction factors, k_f , for the influence quantities of type F and the p correction summands, G_w , for the influence quantities of type S. An example of an equation for the correction is

$$G_{d, \text{corr}} = k_n \cdot \left(G_d - \sum_{w=1}^p G_w \right) \cdot \prod_{f=1}^q k_f \quad (4)$$

where

- G_d is the indication of the dosimeter;
- k_n is the correction factor for non-constant response (nonlinear indication);
- k_f is the correction factor for a quantity whose deviation from its reference value induces a multiplicative change (influence quantity of type F) of the indication;
- G_w is the correction summand for a quantity whose deviation from its reference value induces an additive change (influence quantity of type S) of the indication.

NOTE Subscript 'd' refers to dosimeter.

Formula (4) is useful for the determination of the uncertainty budget according to ISO/IEC Guide 98-3. Whether or not the indication needs to be corrected depends on the level of accuracy required.

With the conventional quantity value of H_o and the corrected indication of $G_{d,corr}$ at the time of the calibration measurement, the calibration coefficient, $N(U,\alpha)_d$, for U and α is given by

$$N(U,\alpha)_d = \frac{H_o}{G_{d,corr}} \quad (5)$$

The calibration coefficient can be determined with different procedures as described in 6.4. The choice of procedure depends on the characteristics of the irradiation facility and the level of accuracy required.

The determination of the calibration coefficient shall be performed at constant dose indication or dose rate indication.

Depending on the number of the defined values for U and α , calibration coefficient $N(U,\alpha)_d$ can be described in two different ways, see Annex B. This results in the fact that $N(U,\alpha)_d$ can be either a calibration coefficient function or a set of single calibration coefficients or one single calibration coefficient accompanied by additional correction factors according to the number of the values for U and α . For purposes of simplification, this International Standard generally refers to $N(U,\alpha)_d$ as *calibration coefficient* for both approaches.

6.2.4 Determination of the measured value

The measurement result, M , is the product of the corrected indication of the dosimeter at any time and the calibration coefficient and is given by

$$M = N(U,\alpha)_d \cdot G_{d,corr} \quad (6)$$

where

M	is the measured value of the dosimeter for radiation quality U and angle of incidence α ;
$N(U,\alpha)_d$	is the calibration coefficient of the dosimeter (see Formula 5);
$G_{d,corr}$	is the corrected indication of the dosimeter at any time, normalized to reference conditions and corrected for any other influences.

6.3 Determination of the response in reference radiation fields

The response is defined as the quotient of the output signal of the dosimeter and the corresponding conventional quantity value of H_o for specified conditions. The output signal can be the indication, G_d , or the corrected indication, $G_{d,corr}$.

For each response value determined, the type of response, i.e. whether it applies to G_d or $G_{d,corr}$, shall be specified, as well as the conditions, e.g. the radiation quality U and angle of incidence α for which it was determined.

The response with respect to the indication of the dosimeter $R(U,\alpha)_{G_d}$ is given by

$$R(U,\alpha)_{G_d} = \frac{G_d}{H_o} \quad (7)$$

The response related to the corrected indication $R(U,\alpha)_{G_{d,corr}}$ is defined analogously.

For the definitions of the symbols, see Clause 4.

NOTE For characterizing or testing a dosimeter, e.g. type testing, measurements are carried out intending to determine the effects of the variation of the value of one influence quantity on the response. The other influence quantities are then maintained at their reference values or at fixed values within the standard test conditions, unless otherwise specified. For such purposes, response values are determined under non-reference conditions. Then, the dosimeter's relative response, r , is often given, which is the quotient of the response under non-reference conditions and the response under reference conditions:

$$r = \frac{R}{R_{\text{ref}}} \quad (8)$$

where R_{ref} is the response under reference conditions and R is the response under non-reference conditions. The relative response can be a useful quantity for describing the variation of response as a function of the energy and / or angle of radiation incidence.

6.4 Methods for the determination of the calibration coefficient

6.4.1 Procedures

For the calibration of a dosimeter, the calibration coefficient $N(U, \alpha)_d$ shall be determined. The following procedures are possible^[35]:

- the standard realized as a measuring device and the dosimeter — or, more precisely, the parts to be irradiated — are irradiated in a short time period, one after the other (see 6.4.2);
- the standard realized as a measuring device and the dosimeter — or, more precisely, the parts to be irradiated — are irradiated simultaneously at the same distance to the source (see 6.4.3);
- an irradiation facility equipped with a calibrated monitor device is used to irradiate the dosimeter or, more precisely, the parts to be irradiated (see 6.4.4);
- a secondary standard realized as a reference radionuclide source unit is used to irradiate the dosimeter or, more precisely, the parts to be irradiated (see 6.4.5).

Which procedure shall be used depends on the characteristics of the irradiation facility and the level of accuracy required. For example, in beta and gamma dosimetry reference radionuclide sources are normally used. Frequently, in X-ray facilities a monitor chamber is installed and is used for calibrating dosimeters.

6.4.2 Sequential irradiation of standard and dosimeter

When the standard is realized as a measuring device, then the calibration procedure may be executed by, firstly, irradiating the standard and, secondly, irradiating the dosimeter — or, more precisely, their parts to be irradiated. This procedure may be used if the basic quantity in the radiation field is stable over the duration of the measurements for the calibration or determination of the response. Stability is judged to be adequate if the stated or required uncertainty of the calibration is achieved. For a dosimeter whose reference point is subsequently positioned at the point of test after the irradiation of the standard, the value of $N(U, \alpha)_d$ at U and α is obtained by

$$N(U, \alpha)_d = \frac{H_0}{G_{d, \text{corr}}} \quad (9a)$$

or

$$N(U, \alpha)_d = \frac{N(U, \alpha)_s \cdot G_{s, \text{corr}}}{G_{d, \text{corr}}} \quad (9b)$$

where

- $N(U, \alpha)_d$ is the value of the calibration coefficient of the dosimeter;
- H_0 is the conventional quantity value of the dose or dose rate;
- $G_{d, \text{corr}}$ is the indication of the dosimeter, normalized to reference conditions and corrected for any other influences, where applicable;

$G_{s,corr}$ is the indication of the secondary standard, normalized to reference conditions and corrected for any other influences, where applicable;

$N(U, \alpha)_s$ is the value of the calibration coefficient of the secondary standard, given in its calibration certificate.

The response of a dosimeter with respect to the corrected indication $R(U, \alpha)_{G_{d,corr}}$ is determined by

$$R(U, \alpha)_{G_{d,corr}} = \frac{G_{d,corr}}{H_o} \quad (10a)$$

$$R(U, \alpha)_{G_{d,corr}} = \frac{G_{d,corr}}{N(U, \alpha)_s \cdot G_{s,corr}} \quad (10b)$$

The symbols are as given above. The response relating to the indication $R(U, \alpha)_{G_d}$ is given analogously.

NOTE The condition of the stability of the radiation field can be checked by performing measurements using the secondary standard before and after the irradiation of the dosimeter. In such cases, $G_{s,corr}$ is the mean value of the measurements before and after.

6.4.3 Simultaneous irradiation of standard and dosimeter

For the calibration procedure using simultaneous irradiation of the standard, realized as a measuring device, and the dosimeter — or, more precisely, their parts to be irradiated — both instruments are positioned in the field by locating them symmetrically to the axis of the radiation field at the same distance from the source. This technique shall be used only if the indication of one instrument is not influenced by the presence of the other in the beam and if the conditions are applied in accordance with 6.6.5 for personal dosimeters. If the effects of influence quantities at the two positions are not identical within the expected statement of uncertainty, then another calibration procedure is recommended.

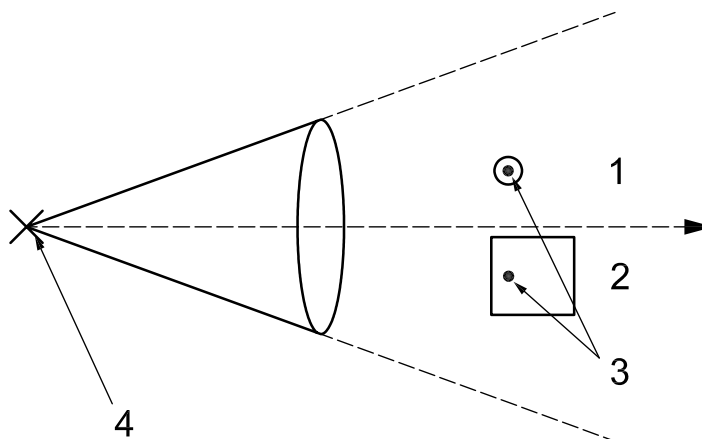

Key

- 1 dosimeter
- 2 standard
- 3 reference point
- 4 source

Figure 2 — Sketch of simultaneous irradiation of standard and dosimeter

If the influence of asymmetry of the radiation field is significant, it shall be eliminated by repeating the measurements after exchanging the positions of the two instruments. The geometrical mean of the value of the calibration coefficient shall be calculated. The value of $N(U, \alpha)_d$ for U and α is then given by

$$N(U, \alpha)_d = \sqrt{\left(\frac{H_o}{G_{d,corr}} \right)_1 \cdot \left(\frac{H_o}{G_{d,corr}} \right)_2} \quad (11a)$$

or

$$N(U, \alpha)_d = N(U, \alpha)_s \cdot \sqrt{\left(\frac{G_{s,corr}}{G_{d,corr}} \right)_1 \cdot \left(\frac{G_{s,corr}}{G_{d,corr}} \right)_2} \quad (11b)$$

where the symbols are as defined in Clause 4 and the indices 1 and 2 refer to the two irradiations.

NOTE Primarily, this procedure will be applicable to those cases in which no phantom is required, e.g. for area dosimeters (area survey instruments). This technique is used particularly for reference radiation qualities produced by accelerators or when using uncollimated sources.

The response of the dosimeter with respect to the corrected indication $R(U, \alpha)_{G_{d,corr}}$ is determined by

$$R(U, \alpha)_{G_{d,corr}} = \frac{G_{d,corr}}{H_o} \quad (12a)$$

or

$$R(U, \alpha)_{G_{d,corr}} = \frac{1}{N(U, \alpha)_s} \cdot \sqrt{\left(\frac{G_{d,corr}}{G_{s,corr}} \right)_1 \cdot \left(\frac{G_{d,corr}}{G_{s,corr}} \right)_2} \quad (12b)$$

The symbols are as given above. The response relating to the indication $R(U, \alpha)_{G_d}$ is given analogously.

6.4.4 Calibration and determination of the response using a calibrated monitor device

For the calibration or the determination of the response of a dosimeter, moderate variations with time in the fluence of the irradiation field can be assessed using a calibrated monitor device. The standard realized as a measuring device and the dosimeter — or, more precisely, the parts to be irradiated — are placed one after the other at the point of test. The procedures are the following.

Firstly, the monitor device is calibrated using a standard (or working measurement standard). The value of the calibration coefficient of the monitor device, $N(U, \alpha)_m$, with respect to H_o for U and α is determined. It is given by

$$N(U, \alpha)_m = \frac{N(U, \alpha)_s \cdot g_{s,corr}}{g_{m,corr}} \quad (13)$$

where

$g_{m,corr}$ is the indication of the monitor device, normalized to reference conditions and corrected for any other influences, where applicable, at the time of the measurement for the calibration of the monitor device;

$g_{s,corr}$ is the indication of the secondary standard, normalized to reference conditions and corrected for any other influences, where applicable, at the time of the measurement for the calibration of the monitor device;

$N(U, \alpha)_s$ is the value of the calibration coefficient of the standard given in its calibration certificate.

NOTE A lower-case g is introduced to distinguish the measurement for the calibration of the monitor device from that for the calibration of the dosimeter. For the latter, capital G is used.

Secondly, the dosimeter — or, more precisely, the parts to be irradiated — is irradiated. The conventional quantity value H_o is given by the calibrated monitor device and can be expressed by

$$H_o = N(\mathbf{U}, \alpha)_m \cdot G_{m,corr}$$

The value of the calibration coefficient of the dosimeter, $N(\mathbf{U}, \alpha)_d$, for \mathbf{U} and α is obtained by

$$N(\mathbf{U}, \alpha)_d = \frac{N(\mathbf{U}, \alpha)_m \cdot G_{m,corr}}{G_{d,corr}} \quad (14)$$

where

$G_{m,corr}$ is the indication of the monitor device, normalized to reference conditions and corrected for any other influences, where applicable, at the time of the measurement for the calibration of the dosimeter;

$G_{d,corr}$ is the indication of the dosimeter, normalized to reference conditions and corrected for any other influences, where applicable;

and the other symbols are as given above.

In practice, if the irradiations of the standard and the dosimeter to be calibrated are performed shortly after one another, the ambient conditions of the monitor will remain nearly the same and corrections of the indication of the monitor device to reference conditions may be unnecessary; nevertheless, they shall be taken into account in the uncertainty budget.

The response of the dosimeter with respect to the corrected indication, $R(\mathbf{U}, \alpha)_{G_{d,corr}}$, at \mathbf{U} and α is determined by

$$R(\mathbf{U}, \alpha)_{G_{d,corr}} = \frac{G_{d,corr}}{N(\mathbf{U}, \alpha)_m \cdot G_{m,corr}} \quad (15)$$

The symbols are as given above. The response relating to the indication $R(\mathbf{U}, \alpha)_{G_d}$ is given analogously.

6.4.5 Calibration and determination of the response using a reference radionuclide source unit

If the calibration of a dosimeter is performed using a reference radionuclide source unit producing \mathbf{U} , the value of $N(\mathbf{U}, \alpha)_d$ at α is given by

$$N(\mathbf{U}, \alpha)_d = \frac{H_o}{G_{d,corr}} \quad (16)$$

where the symbols are as defined in Clause 4.

The conventional quantity value of H_o is calculated from the calibration value of the reference radionuclide source unit.

The response of a dosimeter with respect to the indication or the corrected indication is determined in accordance with 6.3.

6.5 Special considerations for area dosimeters (area survey meters)

6.5.1 Reference point and reference direction

The reference point of the dosimeter and its reference direction are to be stated by the manufacturer. The reference point should be marked on the outside of the dosimeter. If this is impossible the reference point should be indicated in the accompanying documents supplied with the instrument. In the absence of information on the reference point and/or on the reference direction of the dosimeter to be calibrated or tested, these parameters shall be chosen by the calibration or testing laboratory and stated on the certificate containing the results.

All the distance between the radiation source and the reference point of the dosimeter shall be taken as the distance between the effective emission point of the radiation source and the reference point of the dosimeter.

NOTE For the case of point sources in the absence of scattered radiation, the dose rate — for example, dose equivalent rate or air kerma free-in-air rate — changes with the inverse square of the distance, l . A misplacement of the dosimeter's reference point in the beam by the amount of Δl in the direction of the beam will lead to a relative error in the calibration coefficient of $2\Delta l/l$ at l . Misalignment perpendicular to the beam axis by $\Delta\lambda$ causes, in the case of point sources and in the absence of scattered radiation, a relative error of $(\Delta\lambda/l)^2$. In the presence of scattered radiation and for sources of finite dimensions, the above approximations are limited to values of Δl or $\Delta\lambda$ that are small in comparison with l .

6.5.2 Irradiation conditions

All irradiations shall be performed without any phantom, i.e. free in air.

Calibrations or determinations of the response are ideally performed in broad, parallel beams providing a uniform irradiation of the total area of the dosimeter or, more precisely, of the parts to be irradiated, i.e. ideally, the dose rate is constant across the beam diameter. When using a collimated beam, the minimum distance is dependent on the size of the dosimeter and the amount of the scattered radiation from the unit itself. If the dimension of the dosimeter — or, more precisely, of the parts to be irradiated — is such that a complete irradiation is not possible, at least the complete detector shall be irradiated and appropriate corrections shall be applied.

When the irradiation field is not homogeneous across the beam diameter, a correction shall be applied for correcting this effect.

NOTE 1 The choice of the distance between the source and the point of test can be a compromise between several parameters, e.g. the geometry of the irradiation facility, the field homogeneity, the dose rate or the backscatter radiation from the room walls.

NOTE 2 In practice, the irradiation is carried out in more or less divergent beams. Examples are collimated X-ray beams, which are nearly parallel within a sufficient distance, or neutron beams, where it is often necessary to perform calibration measurements at distances where the field is non-homogeneous, e.g. to avoid extremely long irradiation times, in which cases special corrections are necessary^[18].

NOTE 3 For $H'(0,07,\vec{\Omega})$ and $H'(3,\vec{\Omega})$, the calibration coefficient depends on angle α . For a given dosimeter, the exact specification of the rotation axis (e.g. horizontal or vertical) is necessary.

Besides the primary radiation the detector records the radiation scattered by other irradiated components of the dosimeter. If only the detector part of the dosimeter is irradiated, the calibration results and the response may be different compared to a complete irradiation of the dosimeter due to the reduction of scattered radiation. Then, an adequate correction factor shall be used.

6.6 Special considerations for personal dosimeters

6.6.1 General

The measurement quantities are

- for individual monitoring, $H_p(10)$, $H_p(0,07)$ and $H_p(3)$,
- for extremity dosimeters, $H_p(0,07)$ or $H_p(3)$, and
- for whole-body dosimeters, $H_p(10)$ and/or $H_p(0,07)$.

These measurement quantities are defined at points in the human body, and they are measured by placing personal dosimeters at the monitored persons. To have unequivocal reference values for the calibration and the determination of the response, the irradiation of a personal dosimeter is to be performed on an appropriate phantom.

6.6.2 Phantoms

Phantoms shall be used as follows:

- for whole-body dosimeters worn on the trunk, a slab phantom;
- for extremity dosimeters worn on the fingers, a rod phantom;
- for dosimeters worn on the wrist or the ankle, a pillar phantom.

The ICRU has defined a slab phantom made of ICRU tissue. As ICRU tissue is not available as a standard material and as phantoms for extremity dosimeters are also required, the following shall be used:

- a) a water slab phantom, filled with water, with outer dimensions of 30 cm × 30 cm × 15 cm, and walls made of PMMA 2,5 mm thick in the case of the front walls and 10 mm thick for the other walls;
- b) a rod phantom comprising a PMMA cylinder of 19 mm diameter and length of 300 mm;
- c) a water pillar phantom consisting of a water-filled hollow cylinder with walls of PMMA, having an outer diameter of 73 mm and length of 300 mm, and cylinder walls 2,5 mm thick and end faces 10 mm thick.

When such phantoms are employed in accordance with the above, no correction factors shall be applied to the indication of the device assembly under test, even if small differences in backscatter properties exist between these phantoms and those of ICRU tissue^{[17] [20] [36] [39]}.

By agreement between the calibration laboratory and the customer, other phantoms may be used, e.g. for calibrations in terms of $H_p(3)$ ^{[19] [21]}.

6.6.3 Reference direction and reference point

The reference direction of the personal dosimeter is stated by the manufacturer.

The reference point of any personal dosimeter is at the centre of the front surface of the phantom behind the dosimeter. The personal dosimeter is put on the phantom such that the reference direction of the dosimeter through the geometrical centre of its detector(s) — e.g. as specified by the manufacturer — hits the reference point, see Figure 3.

The entire distance between the radiation source and reference point of the personal dosimeter shall be taken as the distance between the effective emission point of the radiation source and the reference point.

6.6.4 Irradiation conditions

The point of test shall be chosen at a distance from the source such that the field size at this position is sufficiently large to allow the irradiation of the entire front surface of the phantom. Ideally, the irradiation shall be done in broad, parallel beams, providing a uniform irradiation of the front surface of the phantom, i.e. the dose rate is constant across the beam diameter. With the use of point sources, this can generally be achieved, approximately by a sufficient distance between the source and the point of test.

NOTE 1 See 6.5.2, Notes 1 and 2.

The quantity $H_p(d)$ being defined in a body, only exists when the person or phantom is present. This means that the body becomes part of the irradiation situation and, in some cases (particularly for neutrons), the radiation field can be modified at the position of the person or phantom by multiple scattering. This can be of special concern when considering calibration in simulated workplace fields^[18]. For the calibration of a dosimeter in such radiation fields of broad direction distribution and/or scattered components, $H_p(d)$ will need to be calculated using the energy and direction distributions of the field incident at depth d in the phantom. The tabulated conversion coefficients cannot be applied for such irradiation situations and a complete simulation of the irradiation set-up will need to be done. For this situation the point of test should be considered at depth d in the phantom below the geometric centre of the front surface^[38].

Extremity dosimeters shall be fixed at half the length of the rod or pillar phantom such that they are attached to the extremity during normal use. The rear side of the dosimeter shall be in contact with the phantom.

Whole-body dosimeters shall be positioned at the centre of the slab phantom surface such that the front surface of the phantom is in contact with the rear side of the dosimeter, see Figure 3. The dosimeter shall be aligned parallel to the phantom front surface without removing any clip fastened on the dosimeter. The reference direction of the dosimeter through its geometrical centre shall hit the reference point.

One dosimeter and an appropriate phantom shall be regarded as a unit. This unit shall be rotated around an axis through the reference point so that the reference direction of the dosimeter forms the desired angle with the direction of radiation incidence. For the angle of incidence of $\alpha = 0^\circ$, the (front) surface of the phantom is perpendicular to the beam axis.

The irradiation of the dosimeter to be calibrated shall be made under conditions identical to those prevailing during the irradiation of the standard. The calibration coefficient or the response shall be obtained with the appropriate equation of Clause 6.

NOTE 2 The calibration coefficient depends on angle α . If this is named the polar angle, it may, in addition, depend also on the azimuthal angle. Therefore, an exact specification of the rotation axis is necessary.

NOTE 3 For an irradiation on the slab phantom it may be practical to rotate the phantom around only one axis and to locate the dosimeter in two mutually perpendicular orientations on the surface of the phantom.

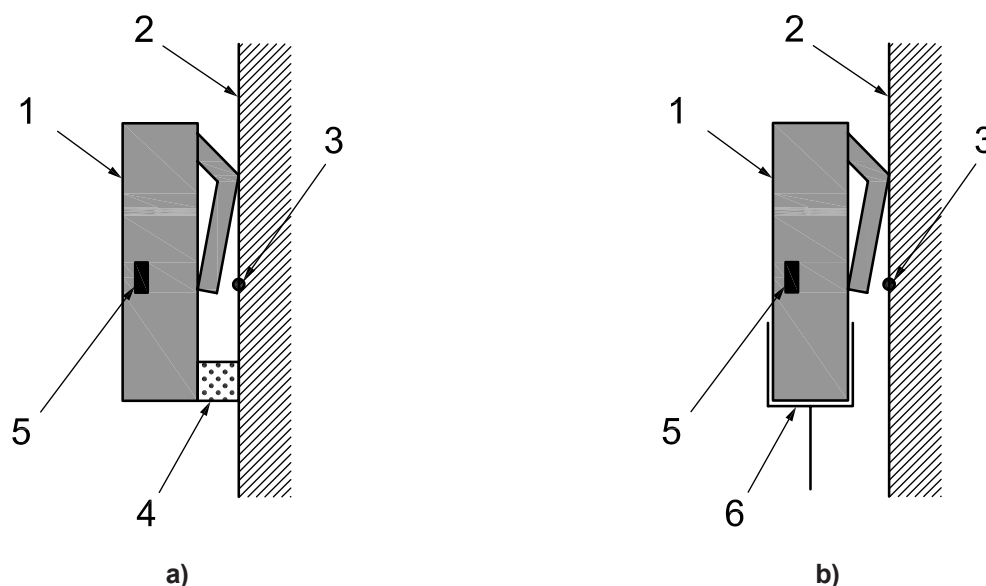

Key

- 1 personal dosimeter
- 2 phantom
- 3 reference point
- 4 spacer
- 5 detector
- 6 stand

Figure 3 — Positioning of whole-body dosimeter at slab phantom surface
(reference direction normal to phantom surface)

6.6.5 Simultaneous irradiation of several dosimeters

In some cases, e.g. for irradiations of several dosimeters to dose values which require long irradiation times, it is convenient to irradiate more than one dosimeter simultaneously.

When several personal dosimeters are irradiated simultaneously on one phantom, some effects associated with this (simplified) procedure require additional attention.

- a) By positioning several dosimeters on the phantom surface the backscatter could be reduced due to the attenuation of the primary radiation passing through the dosimeters. Another effect, especially for neutron radiation, is that by positioning several dosimeters on the phantom surface the scattered radiation of adjacent dosimeters can increase the indication of each dosimeter.
- b) For this special set-up, the reference point shall be defined in the centre of the phantom front surface, irrespective of the arrangement of the dosimeters on the surface. Different distances of the dosimeters from the radiation source shall be considered.
- c) The dosimeters shall cover that part of the phantom surface in which the dose equivalent rate is nearly the same. The requirement on the homogeneity of the dose equivalent rate depends on the required level of accuracy of the measuring result.
- d) The dosimeters shall be positioned on the phantom such that the reference directions are oriented in parallel. Irradiation with the angle of incidence of 0° means that the reference directions are parallel to the direction of the radiation incidence.

For a simultaneous determination of the response of several dosimeters as a function of the direction of radiation incidence, the reference points of all the dosimeters of this special set-up shall be positioned on the axis of rotation.

Before the simultaneous irradiation is adopted, it shall be verified that it leads to results identical to, or with only small deviations from, those obtained when only one dosimeter is irradiated on the phantom. The amount of deviation deemed acceptable depends on the level of accuracy required.

NOTE Certain types of dosimeters may respond very sensitively to small changes in the properties of the backscattered field. This can be due to the use of strongly energy dependent detectors or, possibly, the properties of the algorithms used to arrive at the value of the dose equivalent from the detector signal. In such cases, it might be advisable to have only one dosimeter irradiated in front of the phantom surface for any calibration.

7 Uncertainty

ISO/IEC Guide 98-3 shall be used for the determination of uncertainties and the statement of uncertainty shall be consistent with the approaches recommended therein.

8 Certificates

Calibration certificates shall be prepared in accordance with ISO/IEC 17025:2005, 5.10.4.

Annex A (normative)

List of reference conditions and standard test conditions

If no statement for an influence quantity is given in Table A.1, the reference and standard test condition shall be stated by the manufacturer of the dosimeter or shall be fixed by the calibration or testing laboratory.

Table — Reference conditions and standard test conditions

Influence quantity	Reference condition	Standard test condition (unless otherwise indicated)
Radiation energy (radiation quality)	Stated conditions ^a	As reference condition
Direction of radiation incidence	Stated direction ^a	Stated direction ± 5°
Dose equivalent rate for dose equivalent measurements	Stated dose rate ^a	Stated dose rate ± 10 %
Natural radiation background	Ambient dose equivalent rate $\dot{H}^*(10)$ as low as possible but always lower than 0,1 µSv/h	Ambient dose equivalent rate $\dot{H}^*(10)$ of 0,2 µSv/h or less if practical
Contamination by radioactive material	Negligible	Negligible
Climate (ambient temperature and relative humidity)	+20 °C 50 % relative humidity	+15 °C to +30 °C ^b 30 % to 75 % relative humidity ^b
Atmospheric pressure ^c	101,3 kPa	86 kPa to 106 kPa ^b
Electromagnetic field of external origin	Negligible	Less than the lowest value that causes interference
<p>^a The stated condition shall be contained in the rated range of the dosimeter under calibration.</p> <p>^b The actual values of these quantities at the time of calibration shall be stated and the results corrected to reference conditions or the deviations shall be included in the uncertainty. The values in this table are intended for calibrations or tests performed in temperate climates. In other climates, it may be permitted to exceed the ranges of standard test conditions beyond those stated in this table, where instruments are to be used in these climates.</p> <p>^c In general, the atmospheric pressure is uncontrollable. If, in special cases, the measurements can be performed only at an atmospheric pressure beyond the range of the standard test condition, then this is acceptable.</p>		

Annex B (normative)

Description of the calibration coefficient

Calibration coefficient $N(U, \alpha)$ for radiation quality U and angle of incidence α is expressed by

$$N(U, \alpha) = C_f(U, \alpha) \cdot c_i \quad (\text{B.1})$$

where

- $C_f(U, \alpha)$ is the calibration factor for radiation quality U and angle of incidence α ;
 c_i is the instrument coefficient.

NOTE 1 The calibration coefficient and the calibration factor are defined only under reference conditions.

The calibration coefficient is usually different for different radiation qualities U and angles of incidence α . This might be described by different formalisms. Case a): only one calibration coefficient and additional correction factors for the different radiation qualities U and angles of incidence α are used. Case b): several calibration coefficients are used for each of the combinations of radiation quality U and angle of incidence α . In both cases, the correction factors or the calibration coefficients can be given as a curve or function or as a table of single values.

- a) A single set of reference conditions, including one reference radiation quality, U_{ref} , and one reference angle of incidence, α_{ref} , is defined for which a calibration coefficient, $N(U_{\text{ref}}, \alpha_{\text{ref}})$, and a calibration factor, $C_f(U_{\text{ref}}, \alpha_{\text{ref}})$, respectively, are determined.

For sets of conditions which differ from the set of reference conditions only in the radiation quality and angle of incidence, a calibration coefficient function is established. The j values of the calibration coefficient function for radiation qualities U_l , and angles of incidence α_l , i.e. $N(U_l, \alpha_l)$ ($l = 1, \dots, j$), are given by the product

$$N(U_l, \alpha_l) = N(U_{\text{ref}}, \alpha_{\text{ref}}) \cdot k(U_l, \alpha_l) \text{ with } l = 1, \dots, j \quad (\text{B.2})$$

or, expressed with the calibration factor, $C_f(U_{\text{ref}}, \alpha_{\text{ref}})$, by

$$N(U_l, \alpha_l) = C_f(U_{\text{ref}}, \alpha_{\text{ref}}) \cdot c_i \cdot k(U_l, \alpha_l) \text{ with } l = 1, \dots, j \quad (\text{B.3})$$

where

- $N(U_{\text{ref}}, \alpha_{\text{ref}})$ is the calibration coefficient;
 $k(U_l, \alpha_l)$, is the correction factor for U_l and α_l , and at reference conditions for all other influence quantities;
 $C_f(U_{\text{ref}}, \alpha_{\text{ref}})$ is the calibration factor;
 c_i is the instrument coefficient.

NOTE 2 The single set of reference conditions valid for the calibration coefficient of the standard $N(U_{\text{ref}}, \alpha_{\text{ref}})_s$ may not be the same as those for the calibration coefficient of the dosimeter $N(U_{\text{ref}}, \alpha_{\text{ref}})_d$. The reference radiation quality, U_{ref} , and the reference angle of incidence, α_{ref} , may be chosen differently.

NOTE 3 Correction factor $k(U_l, \alpha_l)$, is dimensionless.

NOTE 4 Although strictly speaking not correct, for simplification, the values of the calibration coefficient function are often named *calibration coefficient*. Therefore, the same symbol is used in this International Standard.

- b) Alternatively, several sets of reference conditions, differing only in the reference radiation quality and the reference angle of incidence, are defined, i.e. j sets of reference conditions, each including a different reference radiation quality, $U_{\text{ref},l} = U_l$, and reference angle of incidence, $\alpha_{\text{ref},l} = \alpha_l$. For each of these j sets of reference conditions, a calibration coefficient, $N(U_l, \alpha_l)$, is determined. This results in j calibration coefficients:

$$N(U_l, \alpha_l) \text{ with } l = 1, \dots, j \quad (\text{B.2})$$

Expressed with the corresponding calibration factors, $C_f(U_l, \alpha_l)$, the calibration coefficients, $N(U_l, \alpha_l)$, are given by

$$N(U_l, \alpha_l) = C_f(U_l, \alpha_l) \cdot c_i \text{ with } l = 1, \dots, j \quad (\text{B.3})$$

where

$C_f(U_l, \alpha_l)$ is the calibration factor under the reference conditions no. l (including reference radiation quality U_l and reference angle α_l);

c_i is the instrument coefficient.

Bibliography

- [1] ISO 4037-1:1996, *X and gamma reference radiation for calibrating dosimeters and doserate meters and for determining their response as a function of photon energy — Part 1: Radiation characteristics and production methods*
- [2] ISO 4037-2:1997, *X and gamma reference radiation for calibrating dosimeters and doserate meters and for determining their response as a function of photon energy — Part 2: Dosimetry for radiation protection over the energy ranges 8 keV to 1,3 MeV and 4 MeV to 9 MeV*
- [3] ISO 4037-3:1999, *X and gamma reference radiation for calibrating dosimeters and doserate meters and for determining their response as a function of photon energy — Part 3: Calibration of area and personal dosimeters and the measurement of their response as a function of energy and angle of incidence*
- [4] ISO 4037-4:2004, *X and gamma reference radiation for calibrating dosimeters and doserate meters and for determining their response as a function of photon energy — Part 4: Calibration of area and personal dosimeters in low energy X reference radiation fields*
- [5] ISO 6980-1:2006, *Nuclear energy — Reference beta-particle radiation — Part 1: Methods of production*
- [6] ISO 6980-2:2004, *Nuclear energy — Reference beta-particle radiation — Part 2: Calibration fundamentals related to basic quantities characterizing the radiation field*
- [7] ISO 6980-3:2006, *Nuclear energy — Reference beta-particle radiation — Part 3: Calibration of area and personal dosimeters and the determination of their response as a function of beta radiation energy and angle of incidence*
- [8] ISO 8529-1:2001, *Reference neutron radiations — Part 1: Characteristics and methods of production*
- [9] ISO 8529-2:2000, *Reference neutron radiations — Part 2: Calibration fundamentals of radiation protection devices related to the basic quantities characterizing the radiation field*
- [10] ISO 8529-3:1998, *Reference neutron radiations — Part 3: Calibration of area and personal dosimeters and determination of response as a function of energy and angle of incidence*
- [11] ISO 12789-1:2008, *Reference radiation fields — Simulated workplace neutron fields — Part 1: Characteristics and methods of production*
- [12] ISO 12789-2:2008, *Reference radiation fields — Simulated workplace neutron fields — Part 2: Calibration fundamentals related to the basic quantities*
- [13] ISO/IEC Guide 99:2007, *International vocabulary of metrology — Basic and general concepts and associated terms (VIM)*
- [14] IEC 60050-394:2007, *International Electrotechnical Vocabulary (IEV) — Part 394: Nuclear instrumentation — Instruments, systems, equipment and detectors*
- [15] IEC 60050-881:1983, *International Electrotechnical Vocabulary (IEV) — Chapter 881: Radiology and radiological physics*
- [16] ANKERHOLD, U., *Catalogue of X-ray spectra and their characteristic data — ISO and DIN radiation qualities, therapy and diagnostic radiation qualities, unfiltered X-ray spectra*, PTB Bericht, PTB-Dos-34, ISBN 3-89701-513-7, April 2000
- [17] BARTLETT, D., DIMBYLOW, P., FRANCIS, T.: Calculated Backscatter from Phantoms for Photon Dosimeter Calibration. *Radiat. Prot. Dosimetry*. 1990, **32** (2) pp. 123–125
- [18] BARTLETT D. Editorial: Personal dose equivalent, $H_p(d)$, and reference point for calibration. *Radiat. Prot. Dosimetry*. 2006, **121** (3) pp. 209–210

- [19] BEHRENS R. Air Kerma to Dose Equivalent Conversion Coefficients not Included in ISO 4037-3. *Radiat. Prot. Dosimetry*. 2010. DOI:10.1093/rpd/ncq459
- [20] BHM. J., ALBERTS, W.G., SWINTH, L.K., SOARES, C.G., MCDONALD, J.C., THOMPSON, I.M.G., KRAMER, H.-M.: ISO Recommended Reference Radiations for the Calibration and Proficiency Testing of Dosimeters and Dose Rate Meters Used in Radiation Protection. *Radiat. Prot. Dosimetry*. 1999, **86** (2) pp. 87–105
- [21] DAURES J., GOURIOU J., BORDY J.M. Monte Carlo Determination of the Conversion Coefficients $H_p(3)/K_a$ in a Right Cylinder Phantom with ‘Penelope’ Code. Comparison with ‘MCNP’ Simulations. *Radiat. Prot. Dosimetry*. 2011, **144** (1–4) pp. 37–42
- [22] GROSSWENDT B. Angular-Dependence Factors and Air Kerma to Dose Equivalent Conversion Coefficients for Cylindrical Phantoms Irradiated by Plane-Parallel Extended Monoenergetic Photon Beams. *Radiat. Prot. Dosimetry*. 1995, **59** (3) pp. 165–179
- [23] GROSSWENDT B. Air Kerma to Dose Equivalent Conversion Coefficients for Cylindrical Phantoms Irradiated by Extended Plane-Parallel Photon Beams of Oblique Incidence Relative to the Cylinder Main Axis. *Radiat. Prot. Dosimetry*. 1995, **59** (3) pp. 195–203
- [24] ICRU 33, *Quantities and Units in Radiation Protection Dosimetry*, International Commission on Radiation Units and Measurements, ICRU Report 33, Bethesda, Maryland 20814, USA, 1980
- [25] ICRU 39, *Determination of Dose Equivalents Resulting from External Radiation Sources*, International Commission on Radiation Units and Measurements, ICRU Report 39, Bethesda, MD, 1985
- [26] ICRU 43, *Determination of Dose Equivalents Resulting from External Radiation Sources — Part 2*, International Commission on Radiation Units and Measurements, ICRU Report 43, Bethesda, MD, 1988
- [27] ICRU 47, *Measurement of Dose Equivalents from External Photon and Electron Radiations*, International Commission on Radiation Units and Measurements, ICRU Report 47, Bethesda, MD, 1992
- [28] ICRU 51, *Radiation Quantities and Units*, International Commission on Radiation Units and Measurements, ICRU Report 51, Bethesda, MD, 1993
- [29] ICRU 57, *Conversion Coefficients for use in Radiological Protection Against External Radiation*, International Commission on Radiation Units and Measurements, ICRU Report 57, Bethesda, Maryland 20814, USA
- [30] ICRU 60, *Fundamental Quantities and Units for Ionizing Radiation*, International Commission on Radiation Units and Measurements, ICRU Report 60, Bethesda, Maryland 20814, USA, 1998
- [31] ICRU 66, *Determination of Operational Dose Equivalent Quantities for Neutrons*, International Commission on Radiation Units and Measurements, ICRU Report 66, Bethesda, MD, 2001
- [32] ICRU 76, *Measurement Quality Assurance for Ionizing Radiation Dosimetry*, International Commission on Radiation Units and Measurements, ICRU Report 76, Bethesda, Maryland 20814, USA, 2006
- [33] ICRP 74, *Conversion coefficients for use in radiological protection against external radiation*, International Commission on Radiological Protection, ICRP Publication 74, Ann. ICRP, Vol. 26, No. 3-4, 1997
- [34] ICRP 103, *The 2007 Recommendations of the International Commission on Radiological Protection*, International Commission on Radiological Protection, ICRP Publication 103, Ann. ICRP, Vol. 37, No. 2-4, 2007
- [35] IAEA Safety Report Series No. 16, *Calibration of Radiation Protection Monitoring Instruments*, International Atomic Energy Agency, January 2000.
- [36] MCDONALD J.C., TANNER J.E., STEWART R.D., MICHEL R., MURPHY M.K., TRAUB R.J. Effect of Phantom Size and Composition on Neutron Dosimeter Reading. *Radiat. Prot. Dosimetry*. 1995, **59** pp. 263–268
- [37] SELTZER. S.M., Calculation of Photon Mass Energy-Transfer and Mass Energy-Absorption Coefficients. *Radiat. Res.* 1993, **136** pp. 147–170

- [38] SCHUMACHER H., NOLTE R., WIEGEL B., ZIMBAL A. Calibration of Personal Dosemeters in Mixed Neutron-Photon Fields: Some Problems and their Solution. *Radiat. Prot. Dosimetry*. 2007, **126** (1-4) pp. 482–486
- [39] TRAUB R.J., MCDONALD J.C., MURPHY M.K. Determination of Photon Backscatter from Several Calibration Phantoms. *Radiat. Prot. Dosimetry*. 1997, **74** pp. 13–20

Bureau of Indian Standards

BIS is a statutory institution established under the *Bureau of Indian Standards Act, 2016* to promote harmonious development of the activities of standardization, marking and quality certification of goods and attending to connected matters in the country.

Copyright

BIS has the copyright of all its publications. No part of these publications may be reproduced in any form without the prior permission in writing of BIS. This does not preclude the free use, in the course of implementing the standard, of necessary details, such as symbols and sizes, type or grade designations. Enquiries relating to copyright be addressed to the Head (Publication & Sales), BIS.

Review of Indian Standards

Amendments are issued to standards as the need arises on the basis of comments. Standards are also reviewed periodically; a standard along with amendments is reaffirmed when such review indicates that no changes are needed; if the review indicates that changes are needed, it is taken up for revision. Users of Indian Standards should ascertain that they are in possession of the latest amendments or edition by referring to the website-www.bis.gov.in or www.standardsbis.in.

This Indian Standard has been developed from Doc No.: CHD 30 (19610).

Amendments Issued Since Publication

Amend No.	Date of Issue	Text Affected

BUREAU OF INDIAN STANDARDS

Headquarters:

Manak Bhavan, 9 Bahadur Shah Zafar Marg, New Delhi 110002

Telephones: 2323 0131, 2323 3375, 2323 9402

Website: www.bis.gov.in

Regional Offices:

	Telephones
Central : 601/A, Konnectus Tower -1, 6 th Floor, DMRC Building, Bhavbhuti Marg, New Delhi 110002	{ 2323 7617
Eastern : 8 th Floor, Plot No 7/7 & 7/8, CP Block, Sector V, Salt Lake, Kolkata, West Bengal 700091	{ 2367 0012 2320 9474
Northern : Plot No. 4-A, Sector 27-B, Madhya Marg, Chandigarh 160019	{ 265 9930
Southern : C.I.T. Campus, IV Cross Road, Taramani, Chennai 600113	{ 2254 1442 2254 1216
Western : Plot No. E-9, Road No.-8, MIDC, Andheri (East), Mumbai 400093	{ 2821 8093

Branches : AHMEDABAD. BENGALURU. BHOPAL. BHUBANESHWAR. CHANDIGARH. CHENNAI. COIMBATORE. DEHRADUN. DELHI. FARIDABAD. GHAZIABAD. GUWAHATI. HIMACHAL PRADESH. HUBLI. HYDERABAD. JAIPUR. JAMMU & KASHMIR. JAMSHEDPUR. KOCHI. KOLKATA. LUCKNOW. MADURAI. MUMBAI. NAGPUR. NOIDA. PANIPAT. PATNA. PUNE. RAIPUR. RAJKOT. SURAT. VISAKHAPATNAM.