

---

---

**Paints and varnishes — Determination  
of resistance to abrasion —**

**Part 2:  
Method with abrasive rubber wheels  
and rotating test specimen**

*Peintures et vernis — Détermination de la résistance à l'abrasion —  
Partie 2: Méthode utilisant des roues abrasives en caoutchouc et une  
éprouvette rotative*





**COPYRIGHT PROTECTED DOCUMENT**

© ISO 2023

All rights reserved. Unless otherwise specified, or required in the context of its implementation, no part of this publication may be reproduced or utilized otherwise in any form or by any means, electronic or mechanical, including photocopying, or posting on the internet or an intranet, without prior written permission. Permission can be requested from either ISO at the address below or ISO's member body in the country of the requester.

ISO copyright office  
CP 401 • Ch. de Blandonnet 8  
CH-1214 Vernier, Geneva  
Phone: +41 22 749 01 11  
Email: [copyright@iso.org](mailto:copyright@iso.org)  
Website: [www.iso.org](http://www.iso.org)

Published in Switzerland

# Contents

	Page
Foreword.....	iv
Introduction.....	v
<b>1 Scope.....</b>	<b>1</b>
<b>2 Normative references.....</b>	<b>1</b>
<b>3 Terms and definitions.....</b>	<b>1</b>
<b>4 Principle.....</b>	<b>2</b>
<b>5 Apparatus and materials.....</b>	<b>3</b>
<b>6 Test specimens.....</b>	<b>5</b>
6.1 Preparation of test specimens.....	5
6.2 Film thickness.....	5
6.3 Conditioning.....	5
<b>7 Procedure.....</b>	<b>5</b>
7.1 Agreements.....	5
7.2 Preparation of the abrasive wheels.....	5
7.3 Test conditions.....	6
7.4 Number of determinations.....	6
7.5 Test procedure.....	6
<b>8 Evaluation.....</b>	<b>6</b>
<b>9 Precision.....</b>	<b>6</b>
<b>10 Test report.....</b>	<b>7</b>
<b>Bibliography.....</b>	<b>8</b>

## Foreword

ISO (the International Organization for Standardization) is a worldwide federation of national standards bodies (ISO member bodies). The work of preparing International Standards is normally carried out through ISO technical committees. Each member body interested in a subject for which a technical committee has been established has the right to be represented on that committee. International organizations, governmental and non-governmental, in liaison with ISO, also take part in the work. ISO collaborates closely with the International Electrotechnical Commission (IEC) on all matters of electrotechnical standardization.

The procedures used to develop this document and those intended for its further maintenance are described in the ISO/IEC Directives, Part 1. In particular, the different approval criteria needed for the different types of ISO documents should be noted. This document was drafted in accordance with the editorial rules of the ISO/IEC Directives, Part 2 (see [www.iso.org/directives](http://www.iso.org/directives)).

Attention is drawn to the possibility that some of the elements of this document may be the subject of patent rights. ISO shall not be held responsible for identifying any or all such patent rights. Details of any patent rights identified during the development of the document will be in the Introduction and/or on the ISO list of patent declarations received (see [www.iso.org/patents](http://www.iso.org/patents)).

Any trade name used in this document is information given for the convenience of users and does not constitute an endorsement.

For an explanation of the voluntary nature of standards, the meaning of ISO specific terms and expressions related to conformity assessment, as well as information about ISO's adherence to the World Trade Organization (WTO) principles in the Technical Barriers to Trade (TBT), see [www.iso.org/iso/foreword.html](http://www.iso.org/iso/foreword.html).

This document was prepared by Technical Committee ISO/TC 35, *Paints and varnishes*, Subcommittee SC 9, *General test methods for paints and varnishes*, in collaboration with the European Committee for Standardization (CEN) Technical Committee CEN/TC 139 *Paints and varnishes*, in accordance with the Agreement on technical cooperation between ISO and CEN (Vienna Agreement).

This third edition cancels and replaces the second edition (ISO 7784-2:2016), which has been technically revised.

The main changes are as follows:

- [Figures 1](#) and [2](#) have been updated;
- some measures in [5.1.4](#), [5.2](#) and in the note to [5.3](#) have been updated;
- the text has been editorially revised and the normative references have been updated.

A list of all parts in the ISO 7784 series can be found on the ISO website.

Any feedback or questions on this document should be directed to the user's national standards body. A complete listing of these bodies can be found at [www.iso.org/members.html](http://www.iso.org/members.html).

## Introduction

This document is one of the three parts of ISO 7784 dealing with test methods for the determination of the resistance to abrasion of coatings using abrasive wheels. The characteristics and differences of these methods are summarized in [Table 1](#).

**Table 1 — Types of method**

Standard	Abrasive wheel		Test specimen movement
	Type	Degree of freedom	
ISO 7784-1	Abrasive paper on rubber wheel	Freely rotatable	Rotation
ISO 7784-2	Abrasive rubber wheel		
ISO 7784-3	Abrasive paper on metal wheel	Rigid – with stroke-dependent rotation <sup>a</sup>	Linear reciprocation

<sup>a</sup> A mechanism rotates the abrasive wheel by a small angle after each double stroke so that a new area of the abrasive paper is effective.

It is preferable that the methods using abrasive-paper covered wheels (in ISO 7784-1 and ISO 7784-3) are applied.



# Paints and varnishes — Determination of resistance to abrasion —

## Part 2: Method with abrasive rubber wheels and rotating test specimen

### 1 Scope

This document specifies a method for determining the resistance to abrasion of coatings, for which two loaded, freely rotatable but eccentrically arranged abrasive rubber wheels affect the coating of the rotating test specimen.

### 2 Normative references

The following documents are referred to in the text in such a way that some or all of their content constitutes requirements of this document. For dated references, only the edition cited applies. For undated references, the latest edition of the referenced document (including any amendments) applies.

ISO 1514, *Paints and varnishes — Standard panels for testing*

ISO 2808, *Paints and varnishes — Determination of film thickness*

ISO 3270, *Paints and varnishes and their raw materials — Temperatures and humidities for conditioning and testing*

ISO 4618, *Paints and varnishes — Terms and definitions*

ISO 48-4, *Rubber, vulcanized or thermoplastic — Determination of hardness — Part 4: Indentation hardness by durometer method (Shore hardness)*

ISO 48-5, *Rubber, vulcanized or thermoplastic — Determination of hardness — Part 5: Indentation hardness by IRHD pocket meter method*

FEPA Standard 43-1, *Grains of fused aluminium oxide, silicon carbide and other abrasive materials for coated abrasives Macrogrits P 12 to P 220<sup>1)</sup>*

### 3 Terms and definitions

For the purposes of this document, the terms and definitions given in ISO 4618 and the following apply.

ISO and IEC maintain terminology databases for use in standardization at the following addresses:

- ISO Online browsing platform: available at <https://www.iso.org/obp>
- IEC Electropedia: available at <https://www.electropedia.org/>

---

1) FEPA: Federation of European Producers of Abrasives.

**3.1  
test specimen**

specimen on which the test is to be carried out

[SOURCE: ISO 7784-1:2023, 3.1]

**3.2  
abrasive wear**

wear, occurring due to laminar removal of coating material on the surface

[SOURCE: ISO 7784-1:2023, 3.2]

**4 Principle**

Two abrasive rubber wheels are mounted to pivoting arms and pressed onto the coating of the rotating test specimen applying the agreed test load. The eccentric arrangement of the axes of the abrasive wheels relative to the axis of rotation causes a crosswise abrasive wear in a ring-shaped zone. The loss of mass of the coating caused by abrasive wear after the agreed number of cycles is determined.

[Figure 1](#) illustrates the test principle.

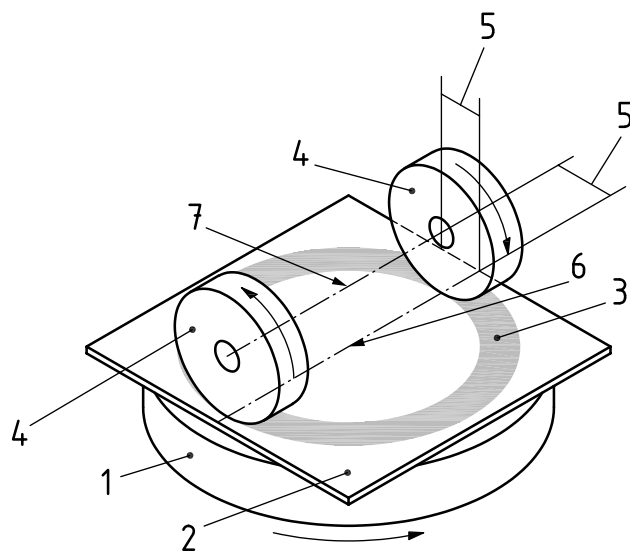

**Key**

- 1 turntable
- 2 test specimen
- 3 wear zone
- 4 abrasive wheels
- 5 offset ( $19,05 \pm 0,3$ ) mm
- 6 axis of rotation (turntable)
- 7 axis of rotation (abrasive wheel)

**Figure 1 — Principle of the abrasion test with rotating test specimen**



## 5 Apparatus and materials

**5.1 Turntable abrasion tester**, as exemplified in [Figure 2](#), with the following properties.

**5.1.1** The rotational speed of the turntable onto which the test specimen is fixed shall be  $(60 \pm 2) \text{ min}^{-1}$ . The number of cycles is pre-set on an operation counter.

**5.1.2** Two arms are attached to the device, each with a mandrel, onto which the abrasive wheels ([5.2](#)) and, if necessary, the weights ([5.3](#)) are attached. Ball bearings are used for the mandrels for the abrasive wheels so they can rotate with low friction.

**5.1.3** It shall be ensured that in lowered condition, the positions of the abrasive wheels relative to the axis of rotation comply with the dimensions indicated in [Figure 2](#).

**5.1.4** A suction device shall be available in order to remove abrasive dust generated during the test. The distance between the suction device and the test specimen shall be  $(3 \pm 1) \text{ mm}$ .

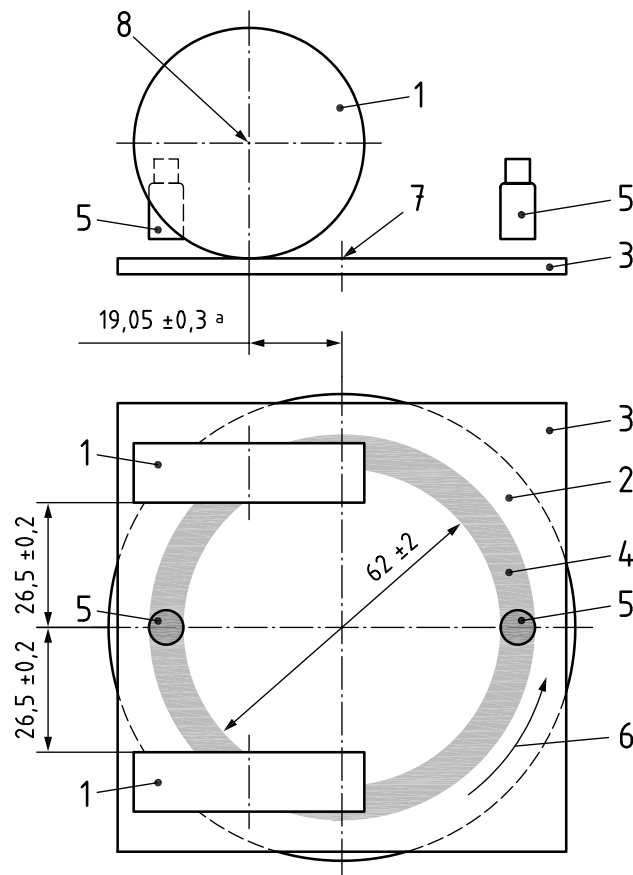

**Key**

- 1 abrasive wheels
- 2 turntable
- 3 test specimen
- 4 wear zone (about 13 mm wide)
- 5 vacuum nozzles
- 6 rotating direction
- 7 axis of rotation (turntable)
- 8 axis of rotation (abrasive wheel)
- a Offset.

**Figure 2 — Schematic diagram of the turntable abrasion tester**

**5.2 Abrasive wheel**, consisting of a cylindrical rubber disc containing abrasive granulate and equipped with an axial bore hole of  $(16,0 \pm 0,1)$  mm for attachment on the supported mandrel on the arm of the apparatus (see 5.1.2). The diameter of the abrasive wheel shall be  $(48,4 \pm 4,0)$  mm and the thickness shall be  $(12,7 \pm 0,2)$  mm.

NOTE 1 The specification of the diameter is understood as the abrasive wheel having a maximum diameter of 52,4 mm in unused condition and that it can be used until worn to a minimum diameter of 44,4 mm.

The hardness of the elastomer material as well as the type, grain size (distribution), and amount of the abrasive filling material, shall be agreed. In Shore A, these elements shall be in accordance with ISO 48-4 or in International Rubber Hardness Degree (IRHD), in accordance with ISO 48-5.

NOTE 2 It is common to agree on the abrasive wheel on the basis of the identification of the abrasive wheel manufacturer.

Two abrasive wheels are required for the test.

**5.3 Weights**, to increase the test load up to about 10 N by attaching to each arm (see [5.1.2](#)).

**NOTE** For a common apparatus, the minimum test load, which is exerted solely by the abrasive wheel and the arms without additional weights, is 2,5 N and with the weights, the test load values 4,9 N and 9,8 N are additionally available for each abrasive wheel. Test load references are per each arm and do not include the mass of the abrasive wheel.

**5.4 Abrasive-paper disc**, grain size P 150 in accordance with FEPA-Standard 43-1, for dressing the abrasive wheels.

**5.5 Balance**, with a maximum permissible error of 0,1 mg.

## 6 Test specimens

### 6.1 Preparation of test specimens

The test specimens shall be plane, have the minimum dimensions of 100 mm × 100 mm, and be prepared, coated, and dried/hardened in accordance with ISO 1514.

For the mentioned dimensions of the test specimen, the minimum distance between wear zone and edge of the test specimen shall be about 7 mm (see [Figure 2](#)).

For a common apparatus, the test specimen is fixed on the turntable by means of an axial screw. For this, the test specimen shall have a bore hole in the centre.

### 6.2 Film thickness

Determine the dry film thickness of the coating, in micrometres, in accordance with one of the methods specified in ISO 2808.

### 6.3 Conditioning

Prior to testing, condition the coated test specimens at a temperature of  $(23 \pm 2)$  °C and a relative humidity of  $(50 \pm 5)$  % in accordance with ISO 3270, if not agreed otherwise, for at least 16 h.

## 7 Procedure

### 7.1 Agreements

For the test procedure, the following shall be agreed:

- the type of abrasive wheel in accordance with [5.2](#), i.e. specification of the rubber material and the abrasive filling material;
- the test load for each abrasive wheel, in newtons;
- the number of cycles, observing [7.5.4](#).

### 7.2 Preparation of the abrasive wheels

The abrasive wheels shall be dressed (i.e. ground in) for 50 cycles prior to each test (single determination in accordance with [7.5](#)) and during the test after every 500 cycles. For dressing, carry out working steps [7.5.2](#) to [7.5.5](#) using a new abrasive-paper disc ([5.4](#)) instead of the test specimen. Select the load of the abrasive wheel and the number of cycles so that after dressing, the abrasive wheels have an exact cylindrical shape and that the edges between the surface and side faces are sharp and even.

### 7.3 Test conditions

Carry out the test at a temperature of  $(23 \pm 2)$  °C and measure the relative humidity during the test and state it in the test report.

Carry out the test as quick as possible, however, not later than 30 min after the conditioning phase.

### 7.4 Number of determinations

Carry out the determination in triplicate on three separate test specimens.

### 7.5 Test procedure

**7.5.1** Weigh the test specimen to 0,1 mg using the balance (5.5) and mount it to the turntable of the apparatus.

**7.5.2** Attach the abrasive wheels, which have been prepared in accordance with 7.2, to the arms of the apparatus and lower onto the coating.

**7.5.3** Load the abrasive wheels, if necessary, in accordance with the agreed test load using an additional weight on each arm (5.3).

**7.5.4** Set the counter to the agreed number of cycles (rotations), turn on the suction device, and start the rotation of the turntable.

In case the agreed number of cycles is higher than 500, the test shall be interrupted after every 500 cycles for re-dressing the abrasive wheels. In order to avoid this, it can be appropriate to agree on a lower number of cycles.

The abrasive wheels can become very smooth when taking up coating material so that they lose their abrasive effect and, consequently, stop rotating (and begin to block). In this case, the test shall be interrupted and the abrasive wheels shall be re-dressed in accordance with 7.2. In order to avoid blocking, it can be appropriate to agree on a lower number of cycles.

In case of wear through of the coating down to the substrate or down to a subjacent coating, a lower number of cycles shall be agreed.

**7.5.5** Clean the test specimen using a lint-free cloth and weigh to the nearest 0,1 mg.

**7.5.6** Repeat working steps 7.5.1 to 7.5.5 with two additional test specimens.

## 8 Evaluation

**8.1** For each of the three test specimens, calculate the loss in mass of the coating as difference of the masses of the test specimens in accordance with 7.5.1 and 7.5.5, in milligrams. Calculate the mean value of the losses in mass of the three test specimens.

**8.2** As the test result, report the mean value of the losses in mass in accordance with 8.1 and the three single values to the nearest 1 mg.

## 9 Precision

No relevant precision data are currently available.

## 10 Test report

The test report shall include at least the following information:

- a) all details necessary to identify and characterize the test specimen, i.e. details regarding
  - 1) coating (manufacturer, product identification, batch number, application method, drying/hardening/ageing conditions, etc.), and
  - 2) substrate (material, thickness, pre-treatment, etc.);
- b) the film thickness, in micrometres, in accordance with [6.2](#);
- c) a reference to this document, i.e. ISO 7784-2:2023;
- d) the agreed type of abrasive wheel in accordance with [5.2](#);
- e) the agreed test load for each abrasive wheel, in newtons;
- f) the agreed number of cycles;
- g) the relative humidity during testing;
- h) the test result in accordance with [8.2](#): the mean loss of mass and the single values, in milligrams;
- i) any deviation from the test method specified;
- j) any unusual features (anomalies) observed during the test;
- k) the name of the operator and the testing laboratory;
- l) the date of the test.

## Bibliography

- [1] ISO 7784-1:2023, *Paints and varnishes — Determination of resistance to abrasion — Part 1: Method with abrasive-paper covered wheels and rotating test specimen*
- [2] ISO 9352, *Plastics — Determination of resistance to wear by abrasive wheels*
- [3] ASTM D4060, *Standard Test Method for Abrasion Resistance of Organic Coatings by the Taber Abraser*
- [4] DIN 53754, *Testing of plastics — Determination of abrasion, abrasive disk method*
- [5] EN 13523-16, *Coil coated metals — Test methods — Part 16: Resistance to abrasion*



