

रंग रोगन, वार्निश और संबंधित उत्पाद के
लिए नमूने और परीक्षण की पद्धतियाँ
भाग 3 रंग रोगन के निर्मित फिल्म पर परीक्षण
अनुभाग 6 पेंडेंट ड्रॉप विधि के उपयोग द्वारा
तरल के सतह तनाव का निर्धारण

**Methods of Sampling and Test of
Paints Varnishes and Related
Products**

**Part 3 Test on Paint Film Formation
Section 6 Determination of the Surface Tension
of Liquid Using the Pendant Drop Method**

ICS 01.40.87

© BIS 2024

© ISO 2017



भारतीय मानक ब्यूरो
BUREAU OF INDIAN STANDARDS
मानक भवन, 9 बहादुर शाह ज़फर मार्ग, नई दिल्ली - 110002
MANAK BHAVAN, 9 BAHADUR SHAH ZAFAR MARG
NEW DELHI - 110002

www.bis.gov.in www.standardsbis.in

NATIONAL FOREWORD

This Indian Standard (Part 3/Sec 6) which is identical to ISO 19403-3 : 2017 'Paints and varnishes wettability — Part 3: Determination of the surface tension of liquids using the pendant drop method' issued by the International Organization for Standardization (ISO) was adopted by the Bureau of Indian Standards on the recommendation of the Paints, Varnishes and Related Products Sectional Committee and approval of the Chemical Division Council.

IS 101 'Methods of test for ready mixed paints and enamel', initially, was published as a unified standard in 1950. The standard was subsequently revised in 1961, 1964 and 1986. During the third revision, recognizing the need for clarity, the committee decided to restructure it by splitting into various parts based on type of tests. These parts included tests on liquid paints (general and physical), chemical examination, film formation, optical assessments, and mechanical tests on paint film formation. Each part was further subdivided into sections, addressing specific tests within those categories. Further, it was decided that whenever a new test method was introduced, it would be integrated into the relevant part of IS 101, ensuring that the standard remained comprehensive.

The document specifies a test method to measure the surface tension of liquids with an optical method using the pendant drop. The method can be applied for the characterization of liquid coating materials.

This Indian Standard (Part 3) is published in several sections. The other sections of this series are:

Sec 1 Drying time

Sec 2 Film thickness

Sec 4 Finish

Sec 5 Determination of fineness of grind

The text of ISO standard has been approved as suitable for publication as an Indian Standard without deviations. Certain conventions and terminologies are, however, not identical to those used in Indian Standards. Attention is particularly drawn to the following:

- a) Wherever the words 'International Standard' appear referring to this standard, they should be read as 'Indian Standard'; and
- b) Comma (,) has been used as a decimal marker in the International Standard, while in Indian Standards, the current practice is to use a point (.) as the decimal marker.

In this adopted standard, the reference appears to certain International Standards for which Indian Standards also exist. The corresponding Indian Standards, which are to be substituted in their respective places, are listed below along with their degree of equivalence for the edition indicated:

<i>International Standards</i>	<i>Corresponding Indian Standard</i>	<i>Degree of Equivalence</i>
ISO 2811-1 Paints and varnishes — Determination of density — Part 1: Pycnometer method	IS 101 (Part 1/Sec 7) : 2020 Methods of sampling and test for paints, varnishes and related products: Part 1 Test on liquid Paints (general and physical), Section 7 Mass per 10 litres — Determination of density — Pycnometer method (<i>fourth revision</i>)	Identical

[*\(Continued on third cover\)*](#)

Contents

Page

1	Scope	1
2	Normative references	1
3	Terms and definitions	1
4	Principle	1
5	Apparatus and materials	1
6	Sampling	3
7	Procedure	3
	7.1 General.....	3
	7.1.1 Setting up the drop contour analysis device.....	3
	7.1.2 Test conditions.....	4
	7.2 Determination of the surface tension of the liquid.....	4
	7.2.1 Preparations.....	4
	7.2.2 Procedure.....	4
8	Evaluation	4
9	Precision	5
	9.1 General.....	5
	9.2 Repeatability limit, <i>r</i>	5
	9.3 Reproducibility limit, <i>R</i>	5
10	Test report	5
	Annex A (informative) Density of test liquids	7
	Annex B (informative) Shape parameter, <i>B</i>	8
	Annex C (informative) Details of an interlaboratory test	9
	Bibliography	12

Indian Standard

METHODS OF SAMPLING AND TEST OF PAINTS VARNISHES
AND RELATED PRODUCTS

PART 3 TEST ON PAINT FILM FORMATION

**SECTION 6 DETERMINATION OF THE SURFACE TENSION OF LIQUID USING
THE PENDANT DROP METHOD**

1 Scope

This document specifies a test method to measure the surface tension of liquids with an optical method using the pendant drop. The method can be applied for the characterization of liquid coating materials. The applicability can be restricted for liquids with non-Newtonian rheology¹⁾.

NOTE For other methods to determine the surface tension, see e.g. EN 14370 and ISO 1409.

2 Normative references

The following documents are referred to in the text in such a way that some or all of their content constitutes requirements of this document. For dated references, only the edition cited applies. For undated references, the latest edition of the referenced document (including any amendments) applies.

ISO 2811 (all parts), *Paints and varnishes — Determination of density*

ISO 4618, *Paints and varnishes — Terms and definitions*

ISO 15528, *Paints, varnishes and raw materials for paints and varnishes — Sampling*

ISO 19403-1, *Paints and varnishes — Wettability — Part 1: Terminology and general principles*

3 Terms and definitions

For the purposes of this document, the terms and definitions given in ISO 4618 and ISO 19403-1 apply.

ISO and IEC maintain terminological databases for use in standardization at the following addresses:

- IEC Electropedia: available at <http://www.electropedia.org/>
- ISO Online browsing platform: available at <http://www.iso.org/obp>

4 Principle

One drop of the respective liquids to be tested is captured hanging from a needle, where the drop shall deviate significantly from the spherical shape due to its own mass. The surface tension is calculated from the shape of the pendant drop in accordance with the Young-Laplace equation.

The polar and disperse fractions of the surface tension can be determined with at least two methods, which are specified in ISO 19403-4 and ISO 19403-5.

5 Apparatus and materials

Ordinary laboratory apparatus, together with the following.

1) This term is defined in DIN 1342-1.

5.1 Drop contour analysis system, for measuring the surface tension of pendant drops.

Any state-of-the-art drop contour analysis system with digital image capture and analysis. [Figure 1](#) shows a schematic example of a drop contour analysis system.

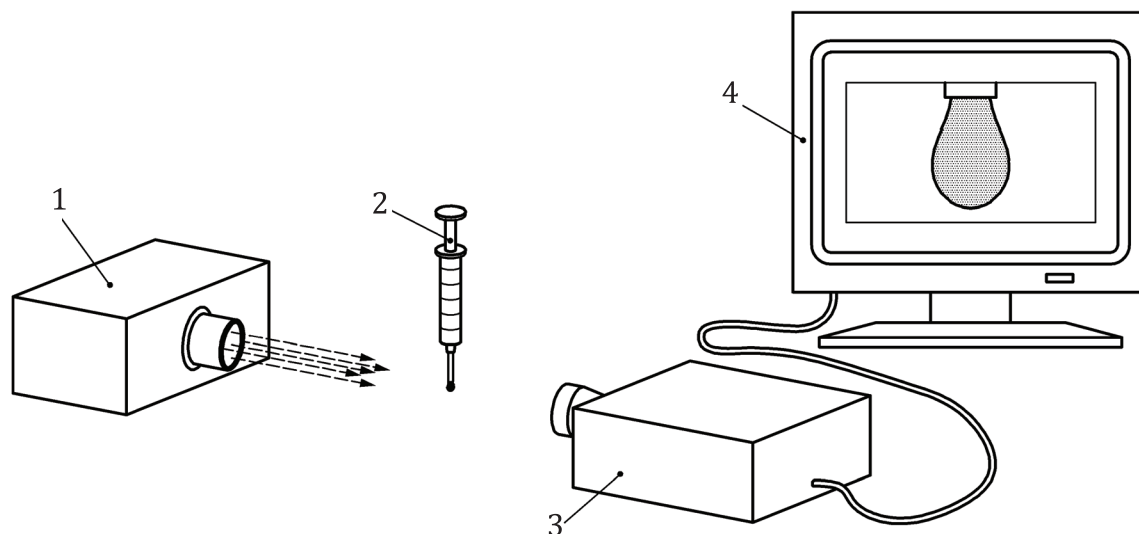

Key

- 1 light source
- 2 graduated micro syringe
- 3 optical system
- 4 screen

Figure 1 — Example of a drop contour analysis system

The image capturing system should be oriented in a way that the optimal image resolution ratio (ratio of width and height) can be used.

NOTE The device used can differ from the schematic diagram in regard to light path and the set-up of the components.

5.2 Dosing unit.

The dosing unit makes it possible to dose a pendant liquid drop, which deviates significantly from the spherical shape due to its own mass, on a circular-cylindrical needle with constant thickness within the detection area of the camera.

For measuring the surface tension on the pendant drop, usually a larger outside diameter of the needle is needed than for measuring the contact angle on the horizontal drop. The outside diameters of the needle used shall be in the range between 0,5 mm and 2,5 mm. The outside diameter of the needle to be chosen depends on the relationship between the surface tension, σ , and the density difference of the liquid to the ambient phase, $\Delta\rho$. The higher the quotient $\sigma/\Delta\rho$, the larger shall be the outside diameter of the needle. The dependence of the outside diameter of the needle, d , on the quotient of surface tension and density difference of the phases involved $\sigma/\Delta\rho$ is illustrated in [Figure 2](#).

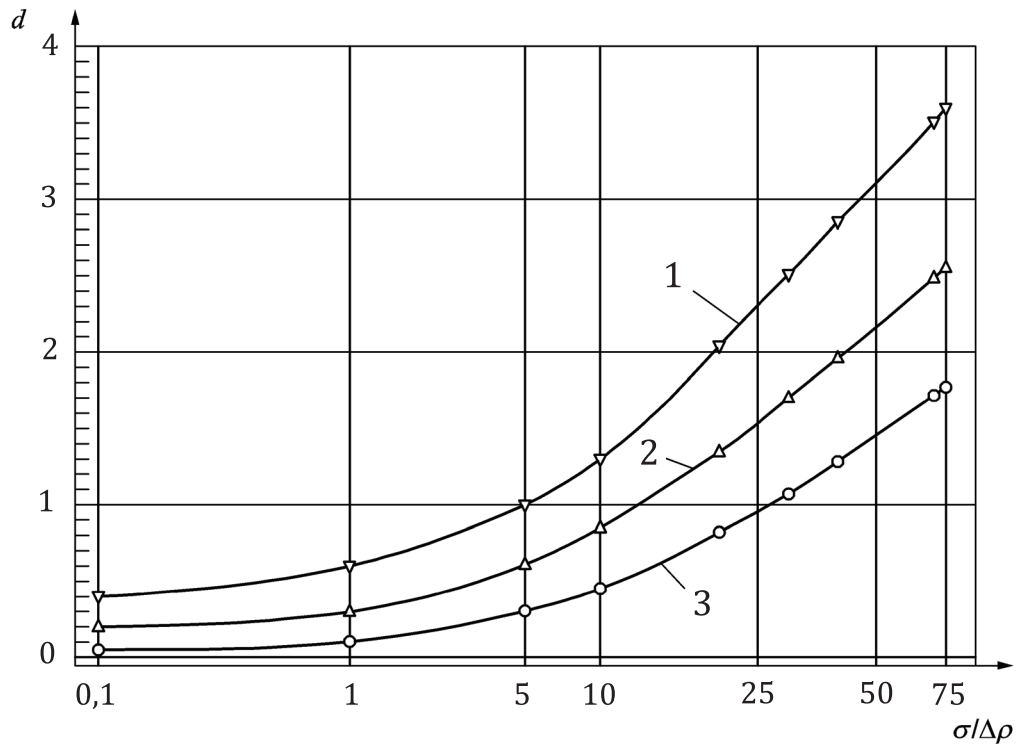

Key

d outside diameter of the needle, in mm

$\sigma/\Delta\rho$ quotients from surface tension and density difference of the phases involved, in $(\text{mN/m})/\text{g} \cdot \text{cm}^{-3}$

1 maximal outside diameter of the needle

2 optimal outside diameter of the needle

3 minimal outside diameter of the needle

Figure 2 — Diagram of the outside diameter of the needle, d , in dependence of the quotient from surface tension and density difference of the phases involved $\sigma/\Delta\rho$

6 Sampling

Take a representative sample of the liquid to be tested in accordance with ISO 15528.

7 Procedure

7.1 General

7.1.1 Setting up the drop contour analysis device

Choose the location of the drop contour analysis device, so that it is exposed to

- no vibrations,
- no intense air flows (e.g. caused by air conditioning), and
- no intense exposure to light from outside (e.g. windows, bright lighting).

Align the drop contour analysis device horizontally.

Obtain the value of the local acceleration of gravity of the installation location and enter in the respective position of the manufacturer software.

7.1.2 Test conditions

Conduct the test at (23 ± 2) °C and a relative humidity of (50 ± 5) % (see ISO 3270) and make sure that all test media have this temperature.

7.2 Determination of the surface tension of the liquid

7.2.1 Preparations

In case it is not given, obtain the density of the liquid and ambient phase in accordance with a method of ISO 2811 series and calculate the density difference. For a selection of densities of frequently used test liquids, see [Table A.1](#).

Set up an image that is sufficient in regard to brightness and contrast (mind the specifications given by the manufacturer). If possible, set the light source of the drop contour analysis device so that the grey values within the drop close to the phase interface do not exceed the value 40 (referring to 256 grey value grades) and amount to between 170 and 200 on the outside of the drop.

NOTE It can be reasonable to test the modes of operation of the optical components by means of two-dimensional images of drops. Such reference images are commercially available.

Determine the outside diameter of the needle precisely to $\pm 0,005$ mm, e.g. by means of a micrometer in accordance with ISO 2808.

Move the needle to the upper margin of the image and bring the edges of the needle into focus. Set up the zoom of the drop contour analysis device so that the outside diameter of the needle takes up at least one eighth of the width of the image, refocus if necessary.

Fill the dosing system with the liquid to be tested. Pay attention to fill without contamination or bubbles.

7.2.2 Procedure

Produce a preferably large pendant drop.

NOTE In order to avoid movements of the pendant drop due to air flows, the drop can be positioned in an appropriate optical cell. In order to reduce changes in concentration due to evaporation, the optical cell can be filled in the lower part with the liquid to be tested.

After final focusing/zooming, carry out the length calibration of the imaging device. Update the lighting, if necessary.

Do not change the zoom and focus after this determination of scale.

Capture an image of the pendant drop with a drop contour appropriate for the evaluation in accordance with [Annex B](#).

It is recommended to save the original image for traceability reasons.

Repeat measuring on at least two more drops of the same liquid.

8 Evaluation

For the evaluation, the theoretical approach in accordance with Young-Laplace, which is specified in ISO 19403-1, is valid. For the practical procedure, it is recommended to use the software supplied by the manufacturers of the devices^[10]. With this software, the mathematical model, which is the basis of the evaluation, is adapted to the contour of the drop. An axially symmetric contour of the drop is a mandatory precondition for the evaluation.

For the quality of the evaluation, two essential criteria are to be regarded.

- a) The shape parameter, B , should lie within the recommended range of $0,60 \pm 0,06$ (see [Figure B.1](#)).
- b) The fit error^[11], which describes the quality of the adaption, should lie below $1 \mu\text{m}$ per measuring point. In case $1 \mu\text{m}$ per measuring point is exceeded, it is recommended to check the measuring conditions, e.g. in regard to axial symmetry.

9 Precision

9.1 General

For the detailed results of an interlaboratory test, see [Annex C](#).

9.2 Repeatability limit, r

The repeatability limit, r , is the value below which the absolute difference between two single test results, each the mean of valid duplicates, can be expected to lie with a probability of 95 % when this method is used under repeatability conditions. In this case, the test results are obtained on identical material by one operator in one laboratory within a short interval of time using the standardized test method. In this document, the repeatability limit, r , is on average $0,7 \text{ mN/m}$ for test liquids and coating materials.

9.3 Reproducibility limit, R

The reproducibility limit, R , is the value below which the absolute difference between two single test results, each the mean of valid duplicates, can be expected to lie with a probability of 95 % when this method is used under reproducibility conditions. In this case, the test results are obtained on identical material by operators in different laboratories using the standardized test method. In this document, the reproducibility limit, R , is on average $1,6 \text{ mN/m}$ for test liquids and $2,2 \text{ mN/m}$ for coating materials.

10 Test report

The test report shall contain at least the following information:

- a) all details necessary to identify the tested product; for test liquids including manufacturer and purity grade;
- b) a reference to this document, i.e. ISO 19304-3;
- c) for the determination of the surface tension of the liquid:
 - 1) the shape parameter, B , for every drop,
 - 2) the fit error (deviation of the contour of the drop obtained by the grey-scale analysis from the calculated contour of the drop),
 - 3) the amount of drops,
 - 4) the result of the measuring of the surface tension (arithmetic mean value and standard deviation), and
 - 5) the density of the tested liquid, including origin of the values;
- d) all deviations from the specified method and their possible influences on the results;
- e) any unusual observation (deviation) during the test;
- f) the type of device;

- g) the name of the test person;
- h) the date of the test.

Annex A (informative)

Density of test liquids

Table A.1 — Density values of the test liquids

Test liquid	Density, ρ , depending on temperature					
	$T = 20\text{ }^{\circ}\text{C}$ g/cm ³	$T = 21\text{ }^{\circ}\text{C}$ g/cm ³	$T = 22\text{ }^{\circ}\text{C}$ g/cm ³	$T = 23\text{ }^{\circ}\text{C}$ g/cm ³	$T = 24\text{ }^{\circ}\text{C}$ g/cm ³	$T = 25\text{ }^{\circ}\text{C}$ g/cm ³
Water	0,998 2	0,998 0	0,997 8	0,997 5	0,997 3	0,997 0
Di-iodomethane	3,320 7	3,318 2	3,315 7	3,313 2	3,310 7	3,308 2
Ethylene glycol	1,113 2	1,112 6	1,111 9	1,111 2	1,110 5	1,109 8
Glycerol	1,261 3	1,260 6	1,259 9	1,259 3	1,258 6	1,258 0
Hexadecane	0,773 5	0,772 8	0,772 1	0,771 3	0,770 6	0,769 9
1-bromo-naphthalene	1,483 4	1,482 4	1,481 4	1,480 4	1,479 4	1,478 4
Benzyl alcohol	1,045 3	1,044 5	1,043 7	1,043 0	1,042 2	1,041 4
cis-Decalin	0,896 7	0,896 0	0,895 2	0,894 5	0,893 7	0,892 9
cis-/trans-Decalin	0,881 0	0,880 2	0,879 5	0,878 7	0,878 0	0,877 2

Annex B (informative)

Shape parameter, B

The shape parameter is defined in ISO 19403-1:2017, 3.2.3. It describes the contour of the drop and is a measure to detect if the drop is sufficiently deformed for the Young-Laplace evaluation.

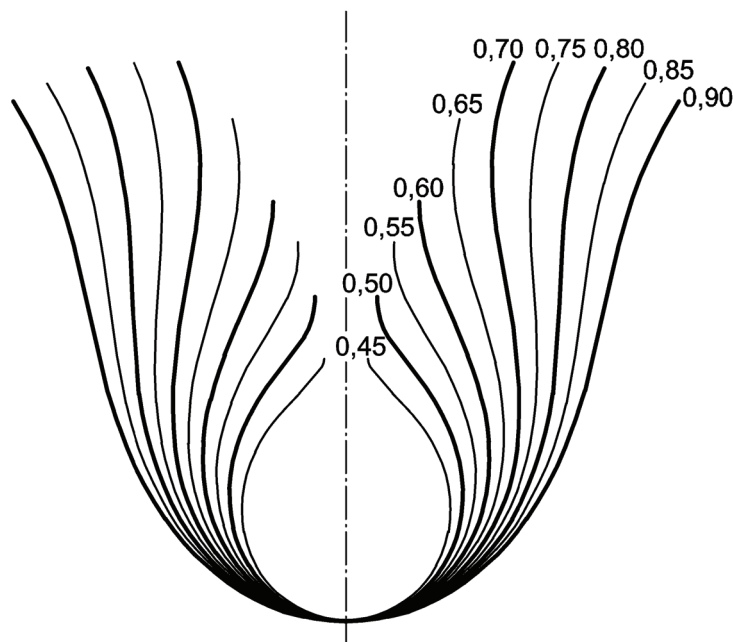

Figure B.1 — Theoretically calculated non-dimensional profiles of pendant drops

The x - and z -coordinates of calculated drop contours in dependence on shape parameter, B , are illustrated. The numbers on the curves indicate the value of the shape parameter, B . The ideal drop contour exists for a B -parameter of $0,60 \pm 0,06$. Drops with B -values below $0,45$ exhibit a shape which is too spherical. Drops with B -values above $0,75$ exhibit a curvature which is too low.

In case problems in regard to compliance with the optimal B -parameter range occur, a needle with a different outside diameter is to be chosen so that B -values between $0,45$ and $0,75$ are achieved (see [5.2](#)).

Annex C (informative)

Details of an interlaboratory test

C.1 General

An interlaboratory test was planned, conducted and evaluated in accordance with ISO 5725-2.

Test liquids and different coating materials were used.

C.2 Test liquids

Twelve laboratories participated in the interlaboratory test.

Three test liquids, which are recommended in ISO 19403-2, were used to obtain the precision data:

- water;
- di-iodomethane;
- ethylene glycol.

The determination was carried out in triplicate. The measured data were subjected to an outliers test in accordance with Grubbs and Cochran. Consequently, the data for water and ethylene glycol of one participant of the interlaboratory test were deleted. The precision results for test liquids are presented in [Table C.1](#) and [Figure C.1](#).

Table C.1 — Precision results for test liquids

		Water	Di-iodomethane	Ethylene glycol	Mean
Mean value	mN/m	72,2	50,7	47,9	
Standard deviation of repeatability, s_r	mN/m	0,32	0,26	0,16	0,24
Standard deviation of reproducibility, s_R	mN/m	0,68	0,33	0,58	0,53
Repeatability limit, r	mN/m	0,9	0,7	0,5	0,7
Reproducibility limit, R	mN/m	1,9	0,9	1,6	1,5

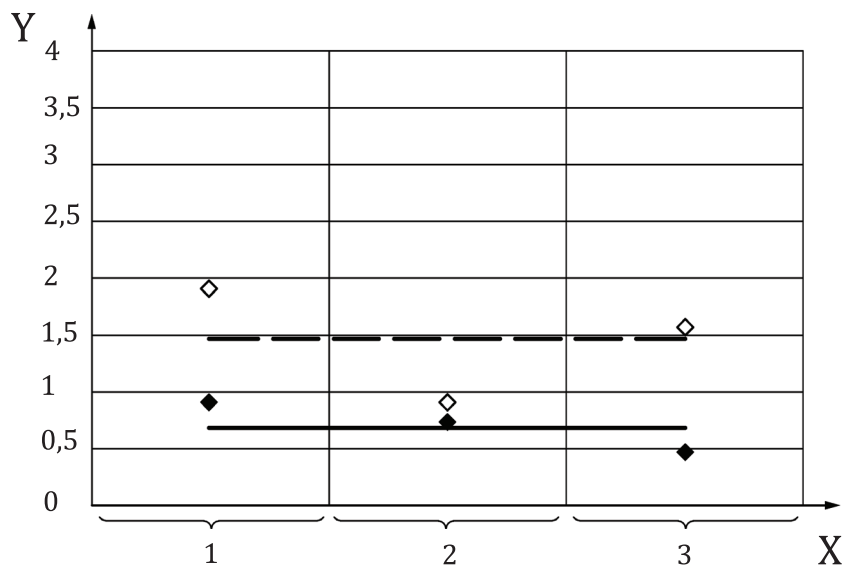

- Key**
- ◆ repeatability limit, r
 - ◇ reproducibility limit, R
 - mean value of repeatability limit, r
 - - - mean value of reproducibility limit, R
 - 1 water
 - 2 di-iodomethane
 - 3 ethylene glycol
 - X test liquid
 - Y surface tension, in mN/m

Figure C.1 — Precision results of the test liquids

C.3 Coating materials

Eight laboratories were involved in the interlaboratory test.

Different coating materials were used.

- Sample 1 Two-component primer 1, water-thinnable
- Sample 2 Two-component primer 2, water-thinnable
- Sample 3 Base paint, water-thinnable
- Sample 4 Varnish, conventional
- Sample 5 Primer, conventional

The determination was carried out in triplicate. The measured data were subjected to an outliers test in accordance with Grubbs and Cochran. Apart from the data of one participant for sample 4, no data were deleted from the interlaboratory test due to the outliers test. For sample 3, a high variance between the participating laboratories was detected. This correlates with the specific rheological flowability of that sample. The rheological characterization shows a yield point, intrinsic viscosity beyond the yield point and thixotropic effects. The precision results for coating materials are presented in [Table C.2](#) and [Figure C.2](#).

Table C.2 — Precision results for coating materials

		Sample 1	Sample 2	Sample 4	Sample 5	Mean value samples 1,2,4,5	Sample 3
Total mean value	mN/m	31,1	29,7	28,5	30,5		28,6
Standard deviation of repeatability, s_r	mN/m	0,22	0,24	0,11	0,24	0,20	0,4
Standard deviation of reproducibility, s_R	mN/m	0,75	0,92	0,40	1,11	0,79	2,2
Repeatability limit, r	mN/m	0,6	0,7	0,3	0,7	0,6	1,2
Reproducibility limit, R	mN/m	2,1	2,6	1,1	3,1	2,2	6,1

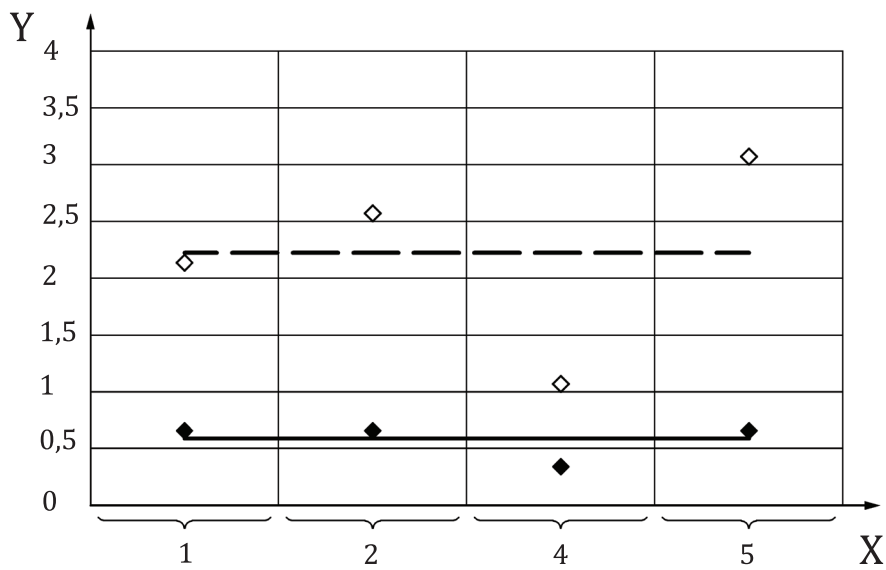

Key

- ◆ repeatability limit, r
- ◇ reproducibility limit, R
- mean value of repeatability limit, r
- - - - - mean value of reproducibility limit, R
- 1 to 5 sample 1 to sample 5
- X test liquid
- Y surface tension, in mN/m

Figure C.2 — Precision results of the coating materials

Bibliography

- [1] ISO 1409, *Plastics/rubber — Polymer dispersions and rubber latices (natural and synthetic) — Determination of surface tension by the ring method*
- [2] ISO 2808, *Paints and varnishes — Determination of film thickness*
- [3] ISO 3270, *Paints and varnishes and their raw materials — Temperatures and humidities for conditioning and testing*
- [4] ISO 5725-2, *Accuracy (trueness and precision) of measurement methods and results — Part 2: Basic method for the determination of repeatability and reproducibility of a standard measurement method*
- [5] ISO 19403-2, *Paints and varnishes — Wettability — Part 2: Determination of the surface free energy of solid surfaces by measuring the contact angle*
- [6] ISO 19403-4, *Paints and varnishes — Wettability — Part 4: Determination of the polar and dispersive fractions of the surface tension of liquids from an interfacial tension*
- [7] ISO 19403-5, *Paints and varnishes — Wettability — Part 5: Determination of the polar and dispersive fractions of the surface tension of liquids from contact angles measurements on a solid with only a disperse contribution to its surface energy*
- [8] DIN 1342-1, *Viscosity — Part 1: Rheological concepts*
- [9] EN 14370, *Surface active agents — Determination of surface tension*
- [10] SONG B., & SPRINGER J. Determination of Interfacial Tension from the Profile of a Pendant Drop Using Computer-Aided Image Processing, *Journal of Colloid and Interface Science*, 184, 1996, 64 to 91
- [11] WILLIAM H. Press, Saul A. Teukolsky, William T. Vetterling und Brian P. Flannery: *Numerical Recipes in C++*. The Art of Scientific Computing, Cambridge University Press; 2nd edition (2002-02-07)
- [12] SONG B. Untersuchung der Oberflächen- und Grenzflächenspannung flüssigkristalliner Verbindungen mittels der Computergestützten Pendant-Drop-Methode, dissertation Berlin 1995

[\(Continued from second cover\)](#)

The Committee has reviewed the provisions of the following International Standards/documents referred in this adopted standard and has decided that they are acceptable for use in conjunction with this Standard:

<i>International Standards</i>	<i>Title</i>
ISO 2811-2	Paints and varnishes — Determination of density — Part 2: Immersed body (plummet) method
ISO 2811-3	Paints and varnishes — Determination of density — Part 3: Oscillation method
ISO 2811-4	Paints and varnishes — Determination of density — Part 4: Pressure cup method
ISO 4618	Paints and varnishes — Vocabulary
ISO 15528	Paints, varnishes and raw materials for paints and varnishes — Sampling
ISO 19403-1	Paints and varnishes — Wettability — Part 1: Vocabulary and general principles

In this adopted standard, reference appears to certain International Standards/documents where the standard atmospheric conditions to be observed are stipulated which are not applicable to tropical/subtropical countries. The applicable standard atmospheric conditions for Indian conditions are (27 ± 2) °C and (65 ± 5) percent relative humidity and shall be observed while using this standard.

In reporting the result of a test or analysis made in accordance with this standard, if the final value, observed or calculated, is to be rounded off, it shall be done in accordance with IS 2 : 2022 'Rules for rounding off numerical values (*second revision*)'.

Bureau of Indian Standards

BIS is a statutory institution established under the *Bureau of Indian Standards Act, 2016* to promote harmonious development of the activities of standardization, marking and quality certification of goods and attending to connected matters in the country.

Copyright

BIS has the copyright of all its publications. No part of these publications may be reproduced in any form without the prior permission in writing of BIS. This does not preclude the free use, in the course of implementing the standard, of necessary details, such as symbols and sizes, type or grade designations. Enquiries relating to copyright be addressed to the Head (Publication & Sales), BIS.

Review of Indian Standards

Amendments are issued to standards as the need arises on the basis of comments. Standards are also reviewed periodically; a standard along with amendments is reaffirmed when such review indicates that no changes are needed; if the review indicates that changes are needed, it is taken up for revision. Users of Indian Standards should ascertain that they are in possession of the latest amendments or edition by referring to the website-www.bis.gov.in or www.standardsbis.in.

This Indian Standard has been developed from Doc No.: CHD 20 (23715).

Amendments Issued Since Publication

Amend No.	Date of Issue	Text Affected

BUREAU OF INDIAN STANDARDS

Headquarters:

Manak Bhavan, 9 Bahadur Shah Zafar Marg, New Delhi 110002

Telephones: 2323 0131, 2323 3375, 2323 9402

Website: www.bis.gov.in

Regional Offices:

	Telephones
Central : 601/A, Konnectus Tower -1, 6 th Floor, DMRC Building, Bhavbhuti Marg, New Delhi 110002	{ 2323 7617
Eastern : 8 th Floor, Plot No 7/7 & 7/8, CP Block, Sector V, Salt Lake, Kolkata, West Bengal 700091	{ 2367 0012 2320 9474
Northern : Plot No. 4-A, Sector 27-B, Madhya Marg, Chandigarh 160019	{ 265 9930
Southern : C.I.T. Campus, IV Cross Road, Taramani, Chennai 600113	{ 2254 1442 2254 1216
Western : Manakalya, 4 th Floor, NTH Complex (W Sector), F-10, MIDC, Andheri (East), Mumbai 400093	{ 283 25838

Branches : AHMEDABAD, BENGALURU, BHOPAL, BHUBANESHWAR, CHANDIGARH, CHENNAI, COIMBATORE, DEHRADUN, DELHI, FARIDABAD, GHAZIABAD, GUWAHATI, HARYNA, HUBLI, HYDERABAD, JAIPUR, JAMMU & KASHMIR, JAMSHEDPUR, KOCHI, KOLKATA, LUCKNOW, MADURAI, MUMBAI, NAGPUR, NOIDA, PARWANOO, PATNA, PUNE, RAIPUR, RAJKOT, SURAT, VIJAYAWADA.