**Footwear — Test methods for heels and
top pieces — Top piece retention
strength**

*Chaussures — Méthodes d'essai relatives aux talons et aux
bonbouts — Force de rétention du bonbout*



PDF disclaimer

This PDF file may contain embedded typefaces. In accordance with Adobe's licensing policy, this file may be printed or viewed but shall not be edited unless the typefaces which are embedded are licensed to and installed on the computer performing the editing. In downloading this file, parties accept therein the responsibility of not infringing Adobe's licensing policy. The ISO Central Secretariat accepts no liability in this area.

Adobe is a trademark of Adobe Systems Incorporated.

Details of the software products used to create this PDF file can be found in the General Info relative to the file; the PDF-creation parameters were optimized for printing. Every care has been taken to ensure that the file is suitable for use by ISO member bodies. In the unlikely event that a problem relating to it is found, please inform the Central Secretariat at the address given below.

© ISO 2004

All rights reserved. Unless otherwise specified, no part of this publication may be reproduced or utilized in any form or by any means, electronic or mechanical, including photocopying and microfilm, without permission in writing from either ISO at the address below or ISO's member body in the country of the requester.

ISO copyright office
Case postale 56 • CH-1211 Geneva 20
Tel. + 41 22 749 01 11
Fax + 41 22 749 09 47
E-mail copyright@iso.org
Web www.iso.org

Published in Switzerland

Foreword

ISO (the International Organization for Standardization) is a worldwide federation of national standards bodies (ISO member bodies). The work of preparing International Standards is normally carried out through ISO technical committees. Each member body interested in a subject for which a technical committee has been established has the right to be represented on that committee. International organizations, governmental and non-governmental, in liaison with ISO, also take part in the work. ISO collaborates closely with the International Electrotechnical Commission (IEC) on all matters of electrotechnical standardization.

International Standards are drafted in accordance with the rules given in the ISO/IEC Directives, Part 2.

The main task of technical committees is to prepare International Standards. Draft International Standards adopted by the technical committees are circulated to the member bodies for voting. Publication as an International Standard requires approval by at least 75 % of the member bodies casting a vote.

Attention is drawn to the possibility that some of the elements of this document may be the subject of patent rights. ISO shall not be held responsible for identifying any or all such patent rights.

ISO 19958 was prepared by the European Committee for Standardization (CEN) in collaboration with Technical Committee ISO/TC 216, *Footwear*, in accordance with the Agreement on technical cooperation between ISO and CEN (Vienna Agreement).

Throughout the text of this document, read “...this European Standard...” to mean “...this International Standard...”.

Contents		page
Foreword.....		v
1	Scope	1
2	Normative references	1
3	Terms and definitions	1
4	Apparatus and materials	1
5	Sampling and conditioning.....	1
5.1	General.....	1
5.2	Preparation	2
6	Test method.....	5
6.1	Principle	5
6.2	Procedure	6
7	Expression of results	6
8	Test report	6

Foreword

This document (EN ISO 19958:2004) has been prepared by Technical Committee CEN /TC 309 "Footwear", the secretariat of which is held by AENOR, in collaboration with Technical Committee ISO/TC 216 "Footwear".

This European Standard shall be given the status of a national standard, either by publication of an identical text or by endorsement, at the latest by March 2005, and conflicting national standards shall be withdrawn at the latest by March 2005.

According to the CEN/CENELEC Internal Regulations, the national standards organizations of the following countries are bound to implement this European Standard: Austria, Belgium, Cyprus, Czech Republic, Denmark, Estonia, Finland, France, Germany, Greece, Hungary, Iceland, Ireland, Italy, Latvia, Lithuania, Luxembourg, Malta, Netherlands, Norway, Poland, Portugal, Slovakia, Slovenia, Spain, Sweden, Switzerland and United Kingdom.

1 Scope

This European Standard specifies a test method for measuring the force required to detach the top piece from the underside of the shoe heel. The test is applicable to heels with the top piece already attached which have been removed from complete shoes, to heels alone with the top piece attached and, in some instances, to heels with separate push-in top pieces. All heels, except reinforced slender heels with top pieces attached by steel spigots and built stacked heels, can be tested by this method.

2 Normative references

The following referenced document is indispensable for the application of this document. For dated references, only the edition cited applies. For undated references, the latest edition of the referenced document (including any amendments) applies.

EN ISO 7500-1 *Metallic materials - Verification of static uniaxial testing machines - Part 1: Tension/compression testing machines (ISO 7500-1:1999)*.

3 Terms and definitions

For the purposes of this European Standard, the following term and definition apply.

top piece retention strength

maximum force, expressed in Newton, required to pull off a top piece from the heel

4 Apparatus and materials

4.1 The following apparatus and materials shall be used.

4.2 Tensile testing machine, complying with the requirements of EN ISO 7500-1 class 2, with a range of 0 N to 1000 N and a constant-rate-of-loading of $15 \text{ N/s} \pm 5 \text{ N/s}$. A constant-rate-of-traverse tester, for which increase of force produces an appreciable movement of the load jaw (e.g. a "pendulum" tester), may be used if the rate of traverse is set to give, on average, the specified rate of force application when a test is carried out. Alternatively, a constant-rate-of-traverse tester for which there is little movement on the load jaw may be used if the top piece is attached to one jaw of the tester via one or more extensible cords which are substantially elastic over the force range of the test and the rate of traverse is adjusted until the specified rate of force application is obtained.

4.3 Drill, with twist drill beats of suitable sizes (see 5.2.1.4 and 5.2.1.5).

4.4 Bolt, of size M 4 or size M 3 for slender heels, and preferably of length 40 mm or more with a small metal ring or loop attached to its head by brazing. If only low heels are being tested, however, the bolt need not be longer than about 20 mm.

4.5 Rod, of diameter 2 mm and appropriate length or one or more strong extensible cords, e.g. nylon shoes laces.

5 Sampling and conditioning

5.1 General

The form of the test piece needs to be varied according to the height of the heels. For medium and high heels the type of test piece shown in Figure 1 is convenient, in which the heel is held by one cord or rod. For heels of less than about 20 mm in height this cord is likely to interfere with the bolt attached to the top piece. In such cases the form of attachment shown in Figure 2 should be used.

5.2 Preparation

5.2.1 Medium and high heels

5.2.1.1 The prepared test piece is illustrated in Figure 1.

5.2.1.2 It is permissible to test heels and top pieces supplied separately, provided the top piece can be attached in the laboratory by essentially the same method as in production. Push-in top pieces shall be inserted fully by pneumatic pressure. Some types of these top pieces are additionally attached by short nails inserted through holes moulded in the top piece. This also may be inserted in the laboratory, by hammering or pneumatic pressure, but the correct nail shall be used. The top piece may be attached by staples using a staple gun provided the staples are the same as those used in production.

The attachment of the top piece may precede or follow the other details of the preparation described in 5.2.1.3, 5.2.1.4 and 5.2.1.5.

5.2.1.3 Cut through the heel stem parallel to the top piece and approximately 30 mm from it, in order to gain access to the cavity and inner side of the top piece or top piece spigot. This may be done with the heel still attached to the shoe or, if preferred, the heel may be detached first by removing the heel attaching pins. For fairly low heels the amount cut off may be reduced to approximately 20 mm provided there is still enough room for the bolt (see 6.2.2). Otherwise the procedure for low heels described in 5.2 should be used. In the case of heels having the "Autoloc" type of top piece attachment which do not have a full height centre cavity in the stem, it is necessary to drill a hole down the centre of the stem from the cut surface to the "Autoloc" cavity or recess on the underside of the heel. The diameter of this hole should be not less than 10 mm.

5.2.1.4 Drill a hole vertically through the centre of the top piece just large enough to accommodate a suitable bolt of the type described in 4.4.

5.2.1.5 Drill the heel stem horizontally from one side to the other approximately 5 mm above the cut surface, as shown in Figure 1, so that the drilled hole, which should be large enough to take the rod or cord described in 4.5, is parallel to the heel breast and passes through the vertical centreline of the top piece.

5.2.2 Low heels

5.2.2.1 The prepared test piece is shown in Figure 2. Where the heel is attached to a shoe, remove it by extracting the heel attaching pins.

5.2.2.2 Cut out any rib or ribs across the centre cavity in the heel, taking care not to damage the top piece when doing this.

5.2.2.3 Drill a hole vertically through the centre of the top piece just large enough to accommodate a suitable bolt of the type described in 4.4.

5.2.2.4 Drill two holes horizontally through the heel from one side to the other, large enough to take the cord described in 4.5. They shall be parallel to the heel breast, approximately 6 mm from the heel/top piece interface and approximately 12 mm on each side of the centre of the top piece.

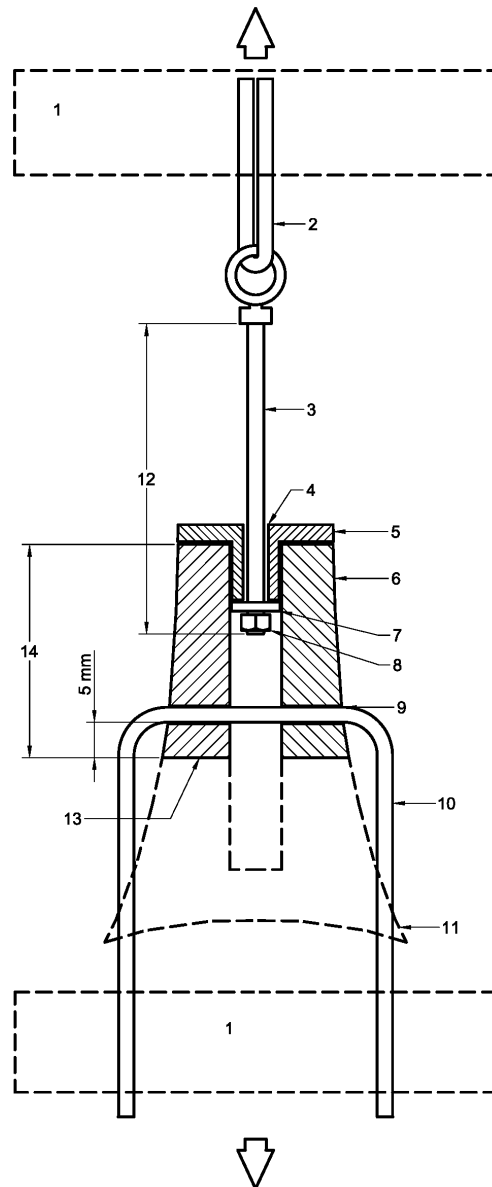

Key

- 1 Tensile machine jaw
- 2 Rod to top jaw
- 3 Bolt
- 4 Drilled hole in top-piece for bolt
- 5 Top-piece
- 6 Heel
- 7 Washer
- 8 Nut
- 9 Drilled hole for rod or cord
- 10 Rod or cord to bottom jaw
- 11 Part of heel not required for test
- 12 At least 40 mm
- 13 Heel cut along this line
- 14 Approximately 30 mm

Figure 1 — Testing of high and medium heels. Side view of testing assembly and section through heel

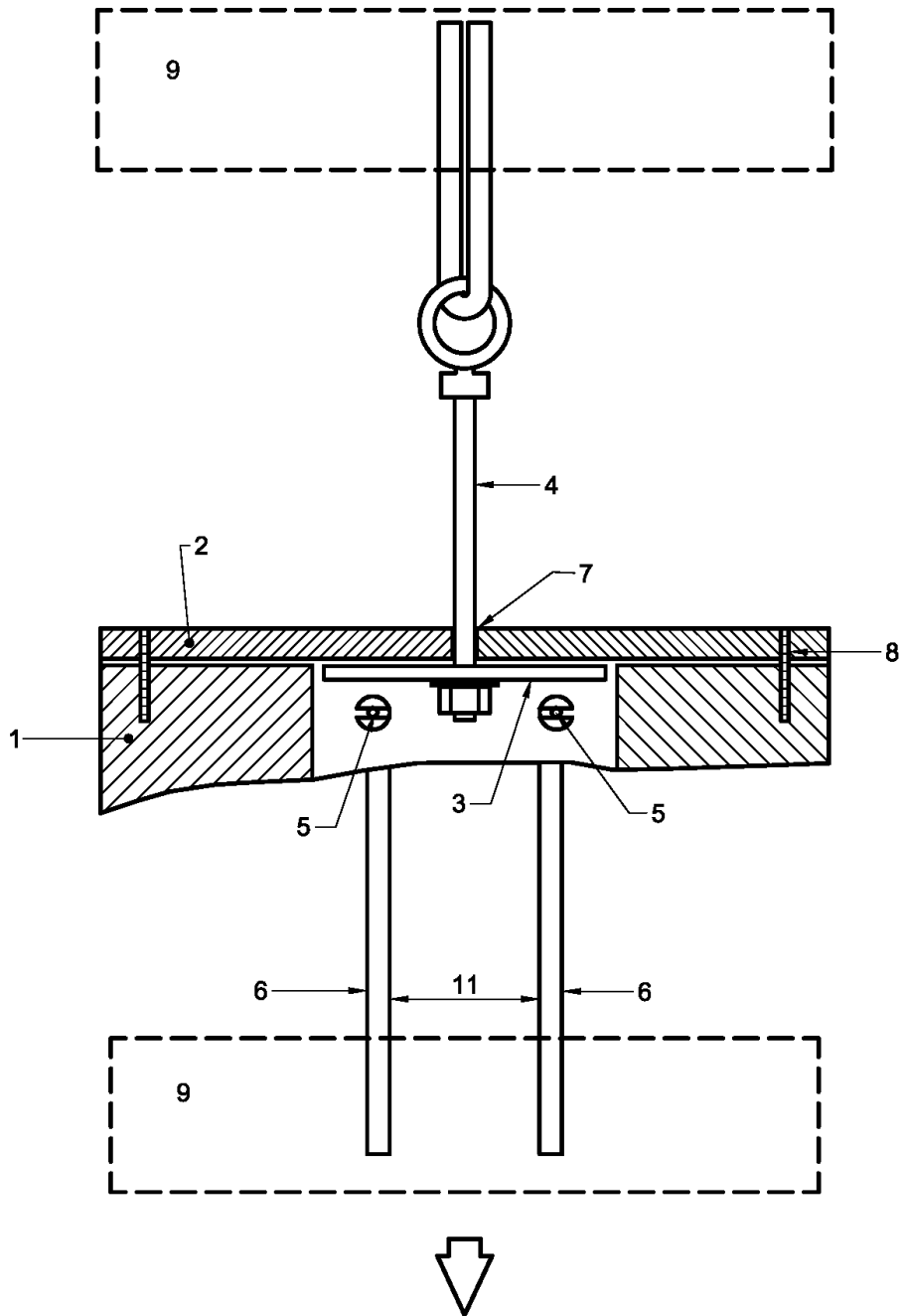
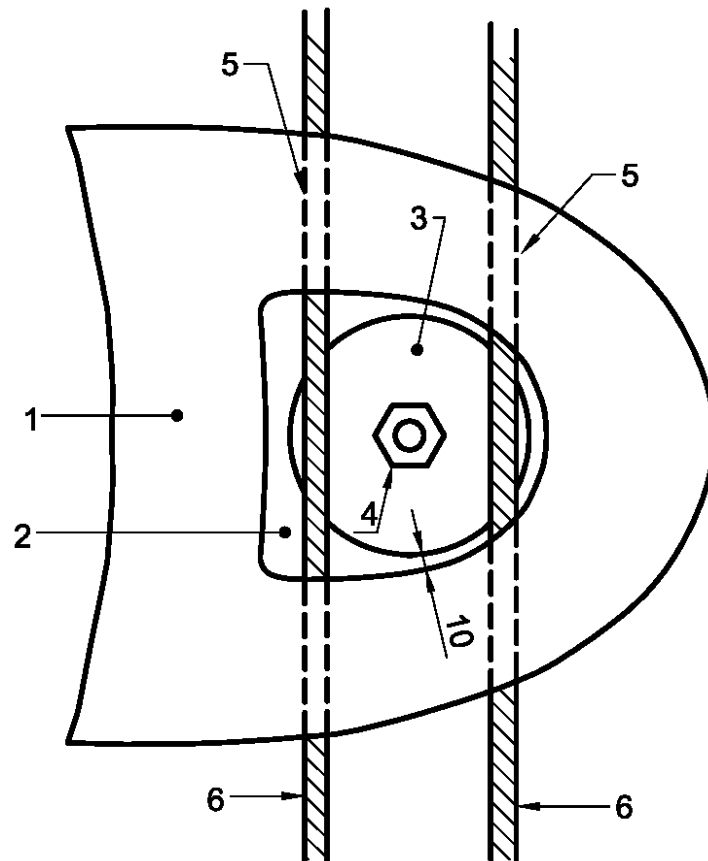

Figure 2a - Side view of test assembly and section through heel and top piece in the heel/toe direction



Key

- 1 Plastic heel
- 2 Top piece
- 3 Washer
- 4 Bolt and nut
- 5 Horizontal hole drilled through heel with cord F insert
- 6 Cord
- 7 Holes drills in top piece with bolt D insert
- 8 Grindery for attaching top piece to heal, inserted during shoe or heel manufacture
- 9 Tensile machine jaw
- 10 Not more than 2 mm
- 11 Approximately 24 mm

Figure 2b - Plan view from underneath with cords laid flat

Figure 2 — Testing of low heels

6 Test method

6.1 Principle

The top piece is pulled off by a steadily increasing force which is applied to its centre perpendicular to the top piece/heel interface. The top piece is first to be drilled to receive a bolt which is attached to one jaw of the tensile machine and the heel cut and drilled to attach it to the other jaw. Several heels need to be tested and the results expressed individually as usually it is the lower values, rather than the average, which are the most important.

6.2 Procedure

6.2.1 Where a constant-rate-of-traverse tensile testing machine is being used, carry out a preliminary test using the procedure described in 6.2.2 to 6.2.5 to establish the rate of traverse which is necessary to get a rate of force application of $15 \text{ N/s} \pm 5 \text{ N/s}$. For a constant-rate-of-loading machine simply set into this specified rate.

6.2.2 Pass the bolt fully through the hole in the top piece from the outside and attach to it a suitable washer and nut. In the case of medium and high heels prepare as in Figure 1 screw on the nut only until the end of the bolt just protrudes through it; if screwed on further, the end of the bolt may prevent the insertion of the rod or cord through the horizontal hole. The washer used should be almost as large as the cavity in the heel, the gap between the edge of the washer and the nearest part of the wall of the cavity being no more than 2 mm.

6.2.3 Attach the bolt to the upper jaw of the tensile testing machine. A loop of welding rod treaded through the ring on the bolt with its ends clamped in the jaws of the machine is a suitable way of doing this.

6.2.4 For medium and high heels, insert a rod or cord horizontally through the hole in the heel stem and attach its ends symmetrically in the lower jaw of the machine (if welding rod is used the ends can be bent and clamped in the jaw).

For low heels, insert two similar cords through the two drilled horizontal holes and clamp the four ends symmetrically so that the heel is horizontal and will remain so during the test (cord is recommended in preference to rod for low heels because it is difficult to bend and clamp rod so that the heel is horizontal).

6.2.5 Start the machine and record the highest force reached as the top piece is pulled out of the heel. For many low heels with large top pieces there will be an initial peak force corresponding to detachment of only part of the top piece. Record this force as well as the highest force reached before the top piece is detached completely (in some cases the initial peak may be the highest force).

6.2.6 Repeat the test with other five top piece/heel assemblies by following the same procedure.

7 Expression of results

For each individual top piece/heel assembly, quote the maximum force, in N, required to detach the top piece completely and the initial peak force (if any). Also describe the types and position of the failures corresponding to these recorded forces.

8 Test report

The test report shall include the following information:

- a) the results, expressed in accordance with clause 7;
- b) a full description of the samples tested, including commercial styles codes, colours, nature, etc.;
- c) reference to the method of test;
- d) the date of testing.

