**Footwear — Test method for slide
fasteners — Attachment strength of
end stops**

*Chaussures — Méthode d'essai pour les fermetures à glissière —
Résistance d'attachement des extrémités*





COPYRIGHT PROTECTED DOCUMENT

© ISO 2015, Published in Switzerland

All rights reserved. Unless otherwise specified, no part of this publication may be reproduced or utilized otherwise in any form or by any means, electronic or mechanical, including photocopying, or posting on the internet or an intranet, without prior written permission. Permission can be requested from either ISO at the address below or ISO's member body in the country of the requester.

ISO copyright office
Ch. de Blandonnet 8 • CP 401
CH-1214 Vernier, Geneva, Switzerland
Tel. +41 22 749 01 11
Fax +41 22 749 09 47
copyright@iso.org
www.iso.org

Contents

	Page
Foreword	iv
1 Scope	1
2 Normative references	1
3 Terms and definitions	1
4 Principle	3
4.1 General.....	3
4.2 Method 1 — Top stop attachment strength.....	3
4.3 Method 2 — Bottom stop attachment strength (Slider-stringer method).....	3
4.4 Method 3 — Bottom stop attachment strength (Stringer-stringer method).....	3
5 Apparatus and materials	4
6 Test specimens	5
7 Procedure	5
7.1 Method 1 — Top stop attachment strength.....	5
7.2 Method 2 — Bottom stop attachment strength (Stringer-slider method).....	6
7.3 Method 3 — Bottom stop attachment strength (Stringer-stringer method).....	6
8 Test report	7
Bibliography	8

Foreword

ISO (the International Organization for Standardization) is a worldwide federation of national standards bodies (ISO member bodies). The work of preparing International Standards is normally carried out through ISO technical committees. Each member body interested in a subject for which a technical committee has been established has the right to be represented on that committee. International organizations, governmental and non-governmental, in liaison with ISO, also take part in the work. ISO collaborates closely with the International Electrotechnical Commission (IEC) on all matters of electrotechnical standardization.

The procedures used to develop this document and those intended for its further maintenance are described in the ISO/IEC Directives, Part 1. In particular the different approval criteria needed for the different types of ISO documents should be noted. This document was drafted in accordance with the editorial rules of the ISO/IEC Directives, Part 2 (see www.iso.org/directives).

Attention is drawn to the possibility that some of the elements of this document may be the subject of patent rights. ISO shall not be held responsible for identifying any or all such patent rights. Details of any patent rights identified during the development of the document will be in the Introduction and/or on the ISO list of patent declarations received (see www.iso.org/patents).

Any trade name used in this document is information given for the convenience of users and does not constitute an endorsement.

For an explanation on the meaning of ISO specific terms and expressions related to conformity assessment, as well as information about ISO's adherence to the WTO principles in the Technical Barriers to Trade (TBT) see the following URL: [Foreword - Supplementary information](#)

The committee responsible for this document is ISO/TC 216, *Footwear*.

Footwear — Test method for slide fasteners — Attachment strength of end stops

1 Scope

This International Standard describes a method intended to determine the attachment strength of the top and bottom stops of a slide fastener. The method is applicable to all types of slide fastener for footwear.

2 Normative references

The following documents, in whole or in part, are normatively referenced in this document and are indispensable for its application. For dated references, only the edition cited applies. For undated references, the latest edition of the referenced document (including any amendments) applies.

ISO 7500-1, *Metallic materials — Tensile testing — Part 2: Verification of the force measuring system of the tensile testing machines*

ISO 18454, *Footwear — Standard atmospheres for conditioning and testing of footwear and components for footwear*

3 Terms and definitions

For the purposes of this document, the terms and definitions given in ISO 19952 and the following apply.

3.1

slide fastener

means of securing two flexible materials consisting of interlockable teeth, each attached to one of the opposing edges of two tapes, and movable slider that spans the interlocking teeth which when moved in one direction causes the teeth of one tape to interlock with the teeth of the other tape and when the slider is moved in the opposite direction causes the teeth to disengage

Note 1 to entry: See [Figure 1](#).

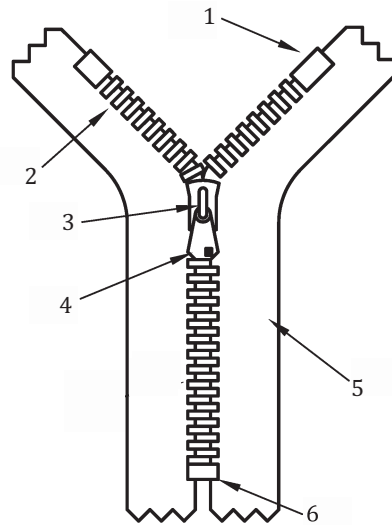

Key

- 1 top stop
- 2 slider
- 3 tape
- 4 teeth
- 5 puller
- 6 bottom stop

Figure 1 — Slide fastener

3.2

tape

fabric panels to support other teeth of the slide fastener

3.3

slider

means of drawing the two interlocking teeth together or apart as it traverses the length of the teeth

3.4

puller

piece of plastic or metal attached to the slider as a means of manual grip for the user to operate

3.5

teeth

individual component of the slide fastener or continuous plastic spiral which interlocks with an opposing element

3.6

end stop/top stop

terminal components of the teeth to prevent the slider from disengaging from the teeth and tape

3.7

stringer

textile tape with an attached row of teeth designed to interact with a row attached to another tape

4 Principle

4.1 General

This International Standard describes the following methods.

4.2 Method 1 — Top stop attachment strength

The slider of a closed fastener is clamped in one jaw of a tensile testing machine and the bottom end of the fastener is clamped in the other jaw. The jaws are then moved apart and the force required to pull the top stops off the fastener is measured.

4.3 Method 2 — Bottom stop attachment strength (Slider-stringer method)

The slider of an open fastener is clamped in one jaw of a tensile testing machine and the two free stringer ends are clamped in the other jaw. The jaws are then moved apart and the force required to pull the bottom stops off the fastener is measured.

4.4 Method 3 — Bottom stop attachment strength (Stringer-stringer method)

The free stringer ends of an open fastener are fitted into the two jaws of a tensile testing machine. The jaws are then moved apart and the force required to pull the bottom stop off is measured.

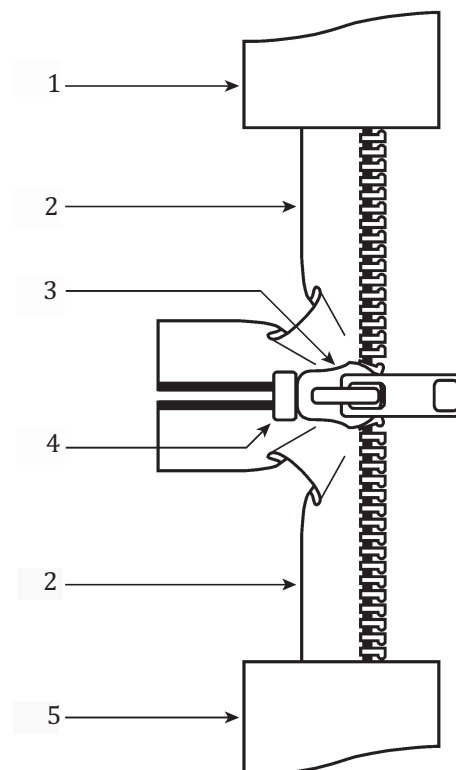

Key

- 1 upper clamp
- 2 stringer
- 3 slider body
- 4 bottom stop
- 5 lower clamp

Figure 2 — Zip closed end test (Method 3)

5 Apparatus and materials

5.1 A tensile testing machine with the following.

5.1.1 A jaw separation rate of (100 ± 10) mm/min.

5.1.2 The capability of measuring forces up to 1 kN to an accuracy of 2 % as specified by Class 2 in ISO 7500-1.

5.1.3 The facility to record either the maximum force obtained during the test, or the force throughout the test.

5.2 For method 1 and method 2, a small hook attachment which will fit into the upper jaw of the tensile testing machine (5.1). The thickness of the hook should be small enough to fit through the hole in the puller of the test fasteners. A hook made from wire of diameter $(1,6 \pm 0,2)$ mm is suitable. The arrangements of these two tests are illustrated in Figure 2 and Figure 3.

Dimensions in millimetres

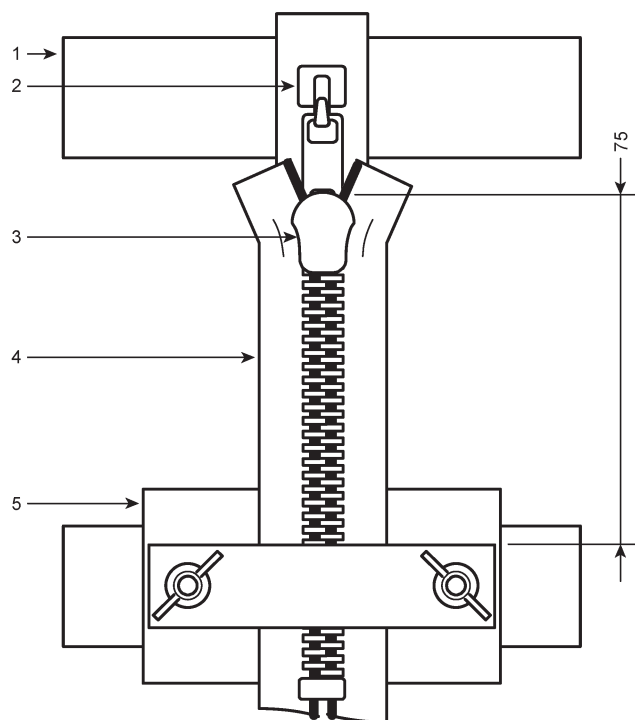

Key

- 1 upper clamp of testing machine
- 2 small hook
- 3 slider puller
- 4 stringer
- 5 lower clamp

Figure 3 — Clamping arrangement for Method 1

Dimensions in millimetres

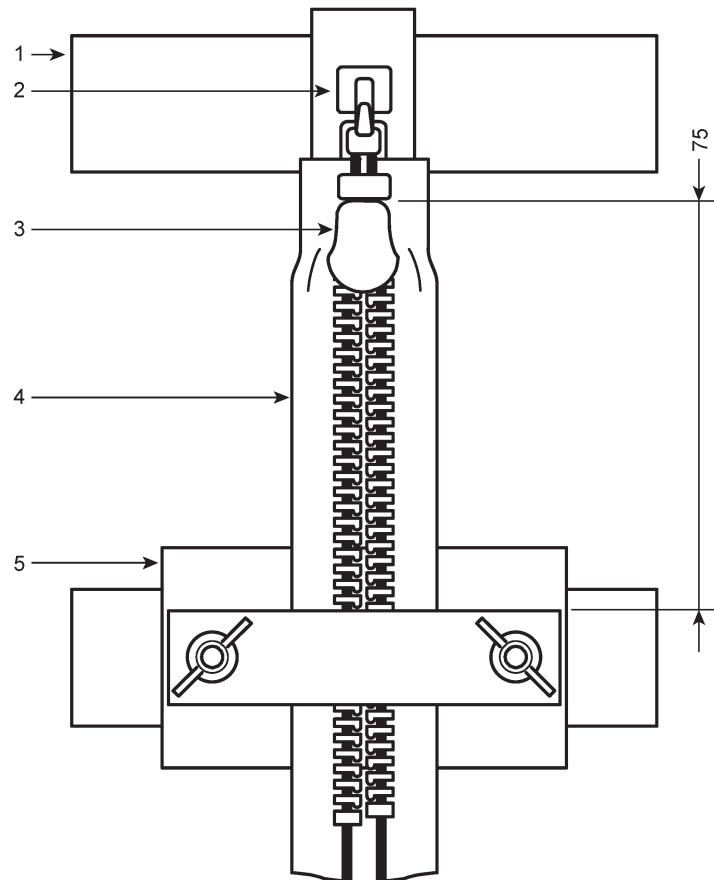
**Key**

- 1 upper clamp of testing machine
- 2 small hook
- 3 slider puller
- 4 stringer
- 5 lower clamp

Figure 4 — Clamping arrangement for Method 2**6 Test specimens**

Three fasteners are required for each of the tests. Condition the test specimens according to ISO 18454 for 24 h before testing and carry out the test in this environment.

7 Procedure

Three versions of the test method can be used.

7.1 Method 1 — Top stop attachment strength

7.1.1 Fit the hook attachment (5.2) into the upper jaw of the tensile testing machine (5.1) and zero the force measurement system (5.1.2).

7.1.2 Close a test fastener so that the slider is against the top stops.

7.1.3 Thread the hook attachment (5.2) through the hole in the puller of the closed fastener.

7.1.4 Clamp the main body of the fastener in the lower jaw of the tensile testing machine. If possible, the fastener should be clamped at a point approximately 75 mm below the slider. Surplus stringer may be cut away if necessary.

7.1.5 Turn on the recording system (5.1.3) of the tensile testing machine.

7.1.6 Operate the tensile testing machine so that the jaws separate at a rate of (100 ± 10) mm/min until the fastener fails.

7.1.7 Record the maximum force obtained, in Newtons, and the type of failure of the fastener such as: end stop pulled off, puller detached, puller broken.

7.1.8 Repeat the procedure in 7.1.2 to 7.1.7 on the two remaining slide fasteners.

7.1.9 Calculate the arithmetic mean of the three maximum forces recorded in 7.1.7.

7.2 Method 2 — Bottom stop attachment strength (Stringer-slider method)

7.2.1 Fit the hook attachment (5.2) into the upper jaw of the tensile testing machine (5.1) and zero the force measurement system (5.1.2).

7.2.2 Open a test fastener so that the slider is against the bottom stop. If the slider is fitted with a locking mechanism, it should be jammed in the off position so that the slider will move freely.

7.2.3 Thread the hook attachment (5.2) through the hole in the puller of the open fastener.

7.2.4 Clamp the two free ends of the stringers in the lower jaw of the tensile testing machine. If possible, the stringers should be clamped at a point approximately 75 mm from the slider. Surplus stringer may be cut away if necessary.

7.2.5 Follow the procedure in 7.1.5 to 7.1.7.

7.2.6 Repeat the procedure in 7.2.2 to 7.2.5 on the two remaining slide fasteners.

7.2.7 Calculate the arithmetic mean of the three maximum forces recorded in 7.1.7.

7.3 Method 3 — Bottom stop attachment strength (Stringer-stringer method)

7.3.1 Open a test fastener so that the slider is against the bottom stop. If the slider is fitted with a locking mechanism, it should be jammed in the off position so that the slider will move freely.

7.3.2 Clamp one of the free ends of the stringer into each of the jaws of the tensile testing machine. If possible, leave approximately 100 mm of each stringer between the jaws and the slider. Surplus stringer may be cut away if necessary.

7.3.3 Follow the procedure in 7.1.5 to 7.1.7.

7.3.4 Repeat the procedure in 7.3.1 to 7.3.3 on the two remaining slide fasteners.

7.3.5 Calculate the arithmetic mean of the three maximum forces recorded in 7.1.7.

8 Test report

The test report shall include the following information:

- a) reference to this International Standard (i.e. ISO 10750);
- b) full description of the samples tested;
- c) date of testing;
- d) the version of the test used: method 1, method 2, or method 3;
- e) the arithmetic mean of the maximum forces and the type(s) of failure;
- f) any deviations from this test method.

Bibliography

- [1] ISO 17709, *Footwear — Sampling location, preparation and duration of conditioning of samples and test pieces*

