**Respiratory protective devices —
Methods of test and test equipment —**

**Part 1:
Determination of inward leakage**

*Appareils de protection respiratoire — Méthodes d'essai et
équipement d'essai —*

Partie 1: Détermination des fuites vers l'intérieur

FOR BIS USE ONLY



FOR BIS USE ONLY



COPYRIGHT PROTECTED DOCUMENT

© ISO 2019

All rights reserved. Unless otherwise specified, or required in the context of its implementation, no part of this publication may be reproduced or utilized otherwise in any form or by any means, electronic or mechanical, including photocopying, or posting on the internet or an intranet, without prior written permission. Permission can be requested from either ISO at the address below or ISO's member body in the country of the requester.

ISO copyright office
CP 401 • Ch. de Blandonnet 8
CH-1214 Vernier, Geneva
Phone: +41 22 749 01 11
Fax: +41 22 749 09 47
Email: copyright@iso.org
Website: www.iso.org

Published in Switzerland

Contents

	Page
Foreword	v
Introduction	vi
1 Scope	1
2 Normative references	1
3 Terms and definitions	1
4 Prerequisites	2
5 General test requirements	2
6 Principle	2
6.1 General	2
6.2 Choice of test agent	2
7 Human test panel	4
7.1 General	4
7.2 Test panel	5
8 Test agents	5
9 Apparatus	6
10 RPD preparation	6
10.1 General	6
10.2 Sample tubes and probe	7
10.3 Sample flow rates	11
10.4 Filtering RPD preparation	11
10.4.1 Unassisted filtering RPD with a connector in accordance with ISO 17420-3	11
10.4.2 Unassisted filtering RPD fitted with particle filters or combination filters	11
10.4.3 Unassisted filtering RPD with gas/vapour or combination filters	11
10.4.4 Assisted filtering RPD with particle filter(s) or combination filter(s)	12
10.4.5 Assisted filtering RPD with gas/vapour or combination filter(s)	12
10.5 Supplied breathable gas devices	12
10.6 Supplied breathable gas devices incorporating additional filtration facility (combined RPD)	13
11 Test methods	13
11.1 General	13
11.2 Test method 1: Sulfur hexafluoride (SF ₆)	14
11.2.1 Test equipment	14
11.2.2 Calculation of leakage	17
11.3 Test method 2: Sodium chloride (NaCl)	17
11.3.1 Test equipment	17
11.3.2 Pulsed sampling — Method 2A	22
11.3.3 Continuous sampling — Method 2B	24
11.4 Test method 3: Corn oil aerosol	24
11.4.1 Test equipment	24
11.5 Determination of inward leakage in the ocular zone	26
12 Test report	26
13 Uncertainty of measurement	27
Annex A (normative) Application of uncertainty of measurement — Determination of compliance	28
Annex B (normative) Test exercise regime	30
Annex C (informative) Material porosity test	34
Annex D (informative) Preparation and use of bivariate test panel	36

Bibliography37

FOR BIS USE ONLY

Foreword

ISO (the International Organization for Standardization) is a worldwide federation of national standards bodies (ISO member bodies). The work of preparing International Standards is normally carried out through ISO technical committees. Each member body interested in a subject for which a technical committee has been established has the right to be represented on that committee. International organizations, governmental and non-governmental, in liaison with ISO, also take part in the work. ISO collaborates closely with the International Electrotechnical Commission (IEC) on all matters of electrotechnical standardization.

The procedures used to develop this document and those intended for its further maintenance are described in the ISO/IEC Directives, Part 1. In particular, the different approval criteria needed for the different types of ISO documents should be noted. This document was drafted in accordance with the editorial rules of the ISO/IEC Directives, Part 2 (see www.iso.org/directives).

Attention is drawn to the possibility that some of the elements of this document may be the subject of patent rights. ISO shall not be held responsible for identifying any or all such patent rights. Details of any patent rights identified during the development of the document will be in the Introduction and/or on the ISO list of patent declarations received (see www.iso.org/patents).

Any trade name used in this document is information given for the convenience of users and does not constitute an endorsement.

For an explanation of the voluntary nature of standards, the meaning of ISO specific terms and expressions related to conformity assessment, as well as information about ISO's adherence to the World Trade Organization (WTO) principles in the Technical Barriers to Trade (TBT) see www.iso.org/iso/foreword.html.

This document was prepared by Technical Committee ISO/TC 94, *Personal safety — Protective clothing and equipment*, Subcommittee SC 15, *Respiratory protective devices*

This second edition cancels and replaces the first edition (ISO 16900-1:2014), which has been technically revised.

The main changes compared to the previous edition are as follows:

- the criteria for selection of test panels has been changed from the principal components analysis (PCA) method to the bivariate grid method. References to the PCA method in other clauses have been modified as necessary;
- a new clause has been added to address measurement of inward leakage in the ocular zone;
- a figure has been added to illustrate the pulsed sampling system;
- the conditions for use of a condensation particle counter have been modified;
- [Annex D](#) has been re-written to reflect changes to the criteria for selection of test panels.

NOTE The list above is not intended as a complete list of all changes.

A list of all parts in the ISO 16900 series can be found on the ISO website.

Any feedback or questions on this document should be directed to the user's national standards body. A complete listing of these bodies can be found at www.iso.org/members.html.

Introduction

This document is intended as a supplement to the respiratory protective devices (RPD) performance standards. Test methods are specified for complete devices or parts of devices. If deviations from the test method given in this document are necessary, these deviations will be specified in the performance standards.

FOR BIS USE ONLY

Respiratory protective devices — Methods of test and test equipment —

Part 1: Determination of inward leakage

1 Scope

This document specifies the test methods for determining inward leakage of respiratory interfaces (RI) and total inward leakage of complete respiratory protective devices (RPD) using specified test agents and incorporating specified body movements, at specified metabolic work rates.

These tests are conducted in laboratories using specific test agents under specified conditions and therefore do not indicate the performance of the device in actual use.

2 Normative references

The following documents are referred to in the text in such a way that some or all of their content constitutes requirements of this document. For dated references, only the edition cited applies. For undated references, the latest edition of the referenced document (including any amendments) applies.

ISO 16972, *Respiratory protective devices — Terms, definitions, graphical symbols and units of measurement*

ISO 16900-5, *Respiratory protective devices — Methods of test and test equipment — Part 5: Breathing machine, metabolic simulator, RPD headforms and torso, tools and verification tools*

ISO 17420-3, *Respiratory protective devices — Performance requirements — Part 3: Thread connection*

ISO 21748, *Guidance for the use of repeatability, reproducibility and trueness estimates in measurement uncertainty evaluation*

ISO/TS 16976-2:2015, *Respiratory protective devices — Human factors — Part 2: Anthropometrics*

3 Terms and definitions

For the purposes of this document, the terms and definitions given in ISO 16972 and the following apply.

ISO and IEC maintain terminological databases for use in standardization at the following addresses:

- ISO Online browsing platform: available at <https://www.iso.org/obp>
- IEC Electropedia: available at <http://www.electropedia.org/>

3.1

assisted filtering RPD

filtering RPD in which air is moved through the filter(s) by means of a blower in addition to the breathing of the wearer

3.2

porous device

RPD incorporating materials, excluding filters, that can be penetrated by gases and vapours during an inward leakage test, leading to an increase of the inward leakage

3.3 unassisted filtering RPD

filtering RPD in which air is drawn through the filter(s) solely by the breathing of the wearer

4 Prerequisites

The performance standards shall indicate the conditions of the test. This includes the following:

- a) minimum number of test samples;
- b) operating conditions of the RPD;
- c) the exercise regime to be used;
- d) if appropriate, the use of crosswinds during particular test exercises;
- e) any exclusions from the test exercise regimes of [Annex B](#);
- f) any prior conditioning, sequence of preconditioning, and/or testing required;
- g) any accessory(ies) of the RPD to be included in the assessment;
- h) Selection of test panel candidates.

5 General test requirements

Unless otherwise specified, the values stated in this document are expressed as nominal values. Except for temperature limits, values which are not stated as maxima or minima shall be subject to a tolerance of $\pm 5\%$. Unless otherwise specified, the ambient conditions for testing shall be between $16\text{ }^{\circ}\text{C}$ and $32\text{ }^{\circ}\text{C}$ and $(50 \pm 30)\%$ RH. Any temperature limits specified shall be subject to an accuracy of $\pm 1\text{ }^{\circ}\text{C}$.

For each of the required measurements performed in accordance with this document, a corresponding estimate of the uncertainty of measurement shall be evaluated. This estimate of uncertainty shall be stated when reporting test results, in order to enable the user of the test report to assess the reliability of the result in accordance with [Annex A](#).

NOTE Uncertainty of measurement can be calculated in accordance with JCGM 100^[1].

6 Principle

6.1 General

A test subject wearing the RPD being tested performs a series of exercises while surrounded by an atmosphere containing a known concentration of a test substance. During these exercises, the concentration of the test substance inside and outside the respiratory interface (RI) is measured and compared.

6.2 Choice of test agent

Three test agents are specified: one solid aerosol, one liquid aerosol, and a gas. The general principle of the test is the same for all substances. The test agent(s) used depend on the type of RPD being tested and are chosen according to [Figure 1](#) and [Figure 2](#). When using sodium chloride as the test agent for respiratory interfaces type T (tight fitting), Method 2A (pulsed sampling) shall be used.

Where a choice of gas or aerosol is permitted according to [Figure 1](#) and [Figure 2](#), the aerosol test methods are preferred. SF₆ is regarded to be a greenhouse gas and its use is deemed undesirable where it could be avoided.

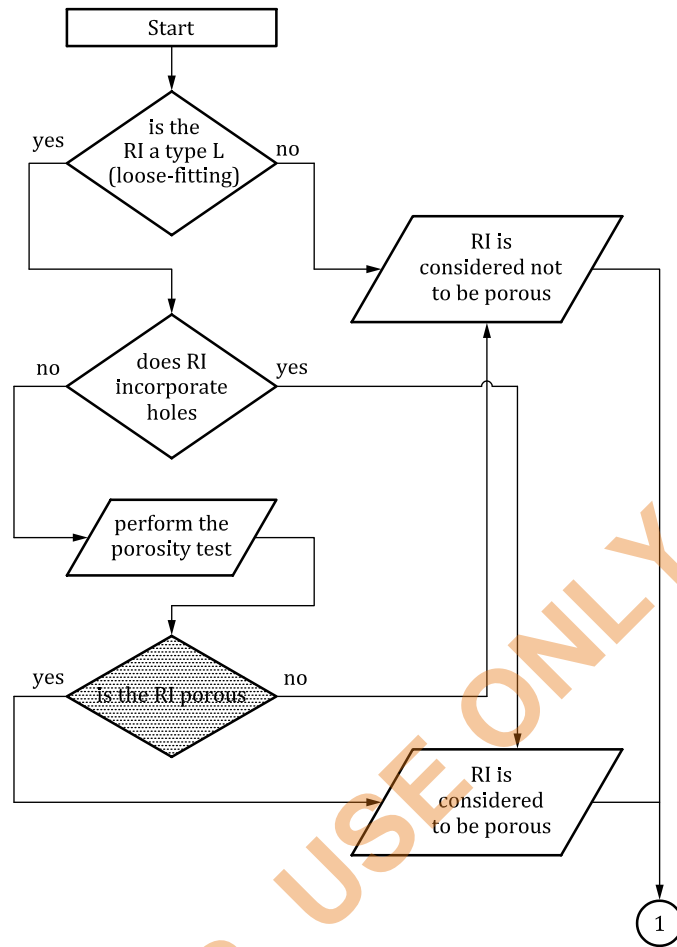

NOTE Excluded are RPD which are obviously open to the atmosphere and which need not be tested using a challenge gas.

Figure 1 — Determination of porosity of RI (Respiratory Interface)

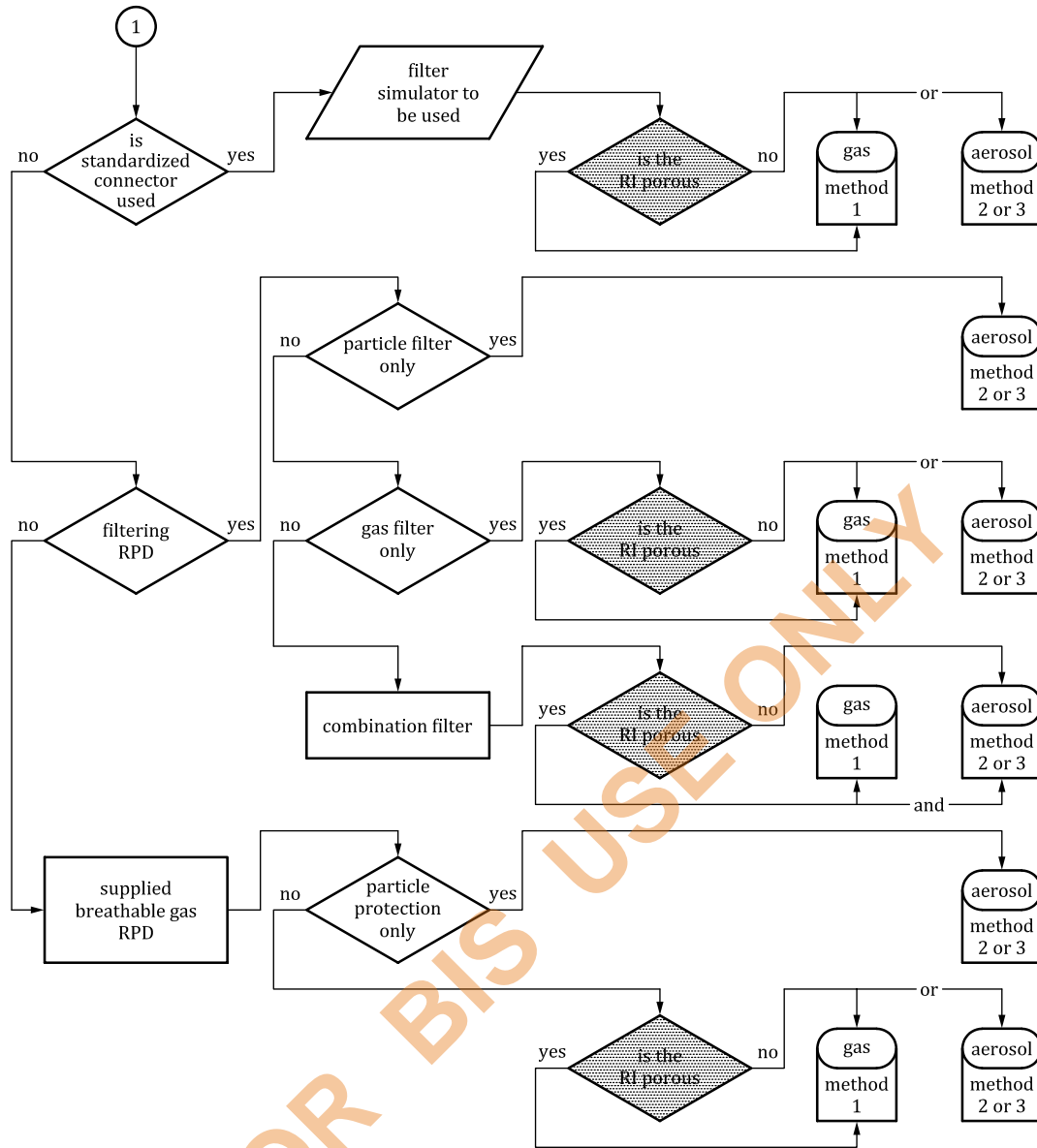

Figure 2 — Determination of test methods for RI (Respiratory Interface)

7 Human test panel

7.1 General

7.1.1 Before performing tests involving human test panels, account should be taken of any national or other regulations concerning, for example the medical history, any known allergies, examination, or supervision of the test subjects.

7.1.2 Test subjects shall be trained in wearing the type of RPD being tested.

7.1.2.1 Unless the information supplied by the RPD manufacturer specifies that the device can be worn by persons with facial hair, then panel members shall be clean shaven in the area of the face seal.

7.1.2.2 Persons with scars or other facial blemishes in the area of the face seal that might give rise to face seal leakage shall not be selected for the test panel.

7.1.2.3 If more than one size of respiratory interface is manufactured, the test subjects shall select the most appropriate size in accordance with the information supplied by the manufacturer.

7.1.3 The test subject shall be informed of all aspects of the test to be undertaken. In particular, where the total length of the test duration is as long as 40 min, it shall be ensured that the test subject is physically able to undertake a test of this duration.

When using particle counting detection methods, the test subject should refrain from smoking for at least 30 min before wearing the RPD.

7.2 Test panel

Unless otherwise specified in the performance standards, the test panel shall consist of 15 test subjects selected according to the following criteria:

- a) Candidates for the test panel shall be measured for face length and face width in accordance with ISO/TS 16976-2:2015, Annex C;
- b) The face length and face width measurements of the candidates shall be used to allocate the candidates to the cells of the bivariate panel according to ISO/TS 16976-2:2015, 8.2, (see [Annex D](#));
- c) Any candidate for whom the bivariate measurements for face width and length fall outside of the limits of the panel (see ISO/TS 16976-2:2015, Figure C.1) shall not be used as a test subject;
- d) The selection of the subjects for a test panel shall take into consideration the size of the respiratory interface as defined by the manufacturer;

NOTE In certain circumstances (e.g. for class dT respiratory interfaces) it can be necessary to take into consideration neck circumference.

- e) Where an RPD equipped with a tight fitting respiratory interface (Type T) is being tested, the fit of the respiratory interface shall be assessed on each subject in accordance with the method specified in the information supplied by the RPD manufacturer. If the respiratory interface does not fit the subject in accordance with the test required by the manufacturer, then that subject shall be excluded from the test panel and shall be replaced with an alternative test subject. The fit assessment described shall be performed in a separate test, prior to the inward leakage assessment

8 Test agents

Three test agents are specified for the inward leakage tests:

- a) test agent 1 = sulfur hexafluoride gas (SF₆);
- b) test agent 2 = sodium chloride aerosol (NaCl);
- c) test agent 3 = corn oil

All three test agents are equally acceptable for determination of inward leakage or total inward leakage, subject to the selection requirements of [Figure 2](#).

If porosity is indicated by the results from the materials porosity test (see [Annex C](#)), then the RPD shall be tested using sulfur hexafluoride gas.

9 Apparatus

9.1 Enclosure, large enough to permit each test subject to complete the test exercise regime without restriction. A uniform and continuous flow of the relevant test atmosphere shall be delivered into the test enclosure.

The enclosure design and air flow management system shall permit the test atmosphere concentration within the area occupied by the RPD and wearer during all exercises to be homogeneous and stable (within $\pm 10\%$) throughout the duration of any test.

The air velocity through the enclosure measured close (within 30 cm) to the test subject's head, with the test subject standing centrally (on the treadmill where appropriate) and without crosswind conditions, shall be sufficient to maintain the specified concentration but shall not exceed 0,2 m/s.

The enclosure shall be designed so that the test subject is visible from the outside of the enclosure at all times while in the enclosure. A means of providing communication between the test subject(s) and the test operator(s) shall be provided.

For RPD to be tested under crosswind conditions, provision shall be made to generate a crosswind of 2 m/s across the enclosure, from the front, rear or side (left or right), in the vicinity of the test subject's head.

NOTE Such provision could need to be adjustable in height to generate the crosswind at the position appropriate for each test subject.

The design of the enclosure shall be such that the device worn by the subject can be supplied with clean air (free of the test agent), where necessary.

The volume of the test chamber shall be large enough, and the replacement rate of the test atmosphere shall be such as to prevent dilution of the test atmosphere by clean air emanating from the device under test.

When SF₆ gas is employed as the test atmosphere, the test chamber should preferably permit recirculation of the air/SF₆ volume to minimize exhaust of SF₆ into the ambient atmosphere.

9.2 Treadmill, capable of working up to the speed as required by the exercise regime defined in [Annex B](#), shall be used.

9.3 Test agent generator - General, capable of generating the test agent in the required concentration, and, in case of an aerosol, of the required particle size distribution.

9.4 Detection system - General, either one detector or different detectors for measuring the test enclosure and the respiratory interface sample concentrations.

The detection system including sampling probes and connections shall have a response time of less than 20 s for a response of 10 % to 90 % of the full-scale deflection of the range used. Further details of the detections system required for each specified test agent are given in [11.2](#), [11.3](#), and [11.4](#).

10 RPD preparation

10.1 General

Prior to the inward leakage test, examine the RPD in accordance with the information supplied by the manufacturer to ensure that it is in good working condition and can be used without hazard to the test subject.

Prepare the RPD to be tested in accordance with their design, the test agent to be used, and whether the inward leakage of a respiratory interface or the total inward leakage of a complete device is to be determined. Further details are given in [10.4](#), [10.5](#), and [10.6](#).

10.2 Sample tubes and probe

In order to sample and analyse the air inside the respiratory interface, make a hole in the respiratory interface and insert a light weight probe through which the sample is drawn by a suitable sample pump.

Wherever possible a multiple-hole sampling probe ([Figure 3](#) and [Figure 4](#)) should be used to minimize sampling bias within the respiratory interface. Wherever a single-hole probe is used the entry shall contain a chamfer. An example is shown in [Figure 5](#). [Figures 6](#) to [9](#) show the positions of the sampling probes in different types of respiratory interface. The materials of the probe can be chosen to match the respiratory interface design under test, for example to minimise the weight of the probe assembly.

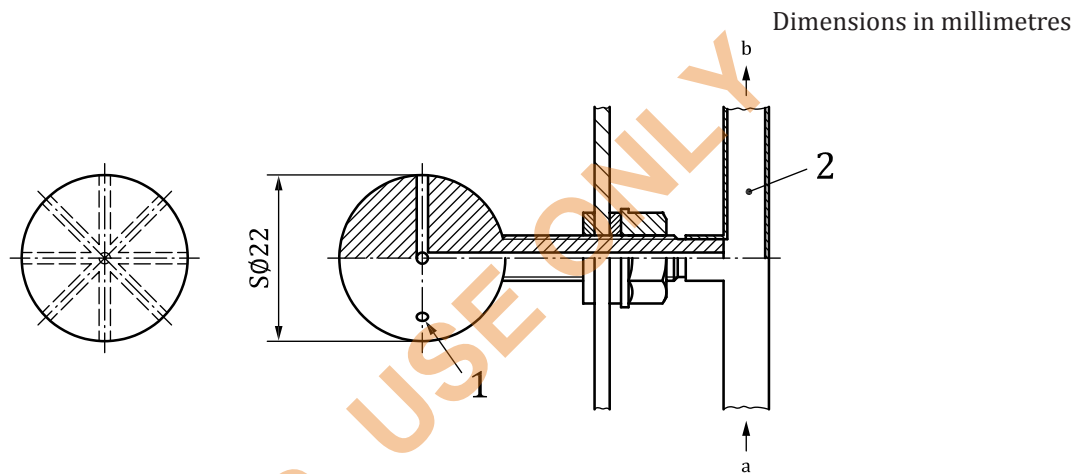

Key

- 1 eight holes, diameter 1,5 mm, equally spaced
- 2 suitable flexible tube
- a Direction of drying air (for sodium chloride only).
- b Connection to sample pump.

Figure 3 — Example of ball probe

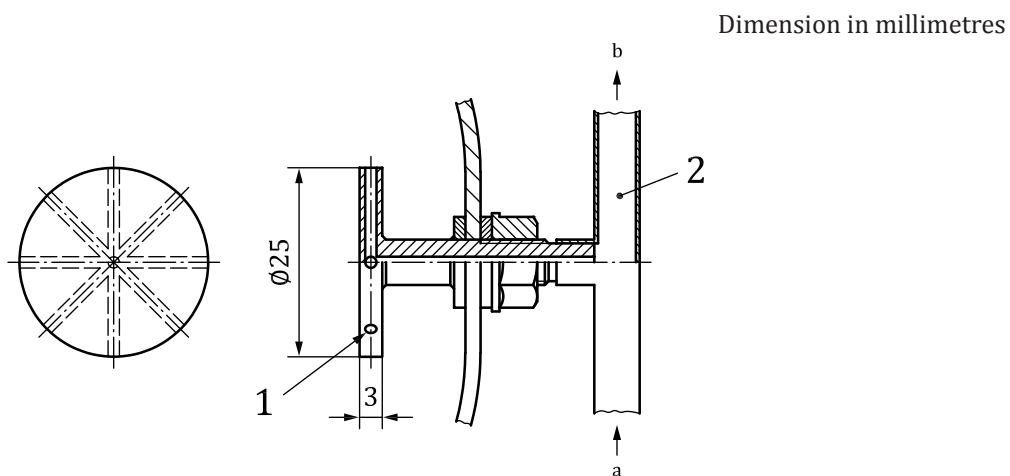

Key

- 1 eight holes, diameter 1,5 mm, equally spaced
- 2 suitable flexible tube
- a Direction of drying air (for sodium chloride only).
- b Connection to sample pump.

Figure 4 — Example of disc probe

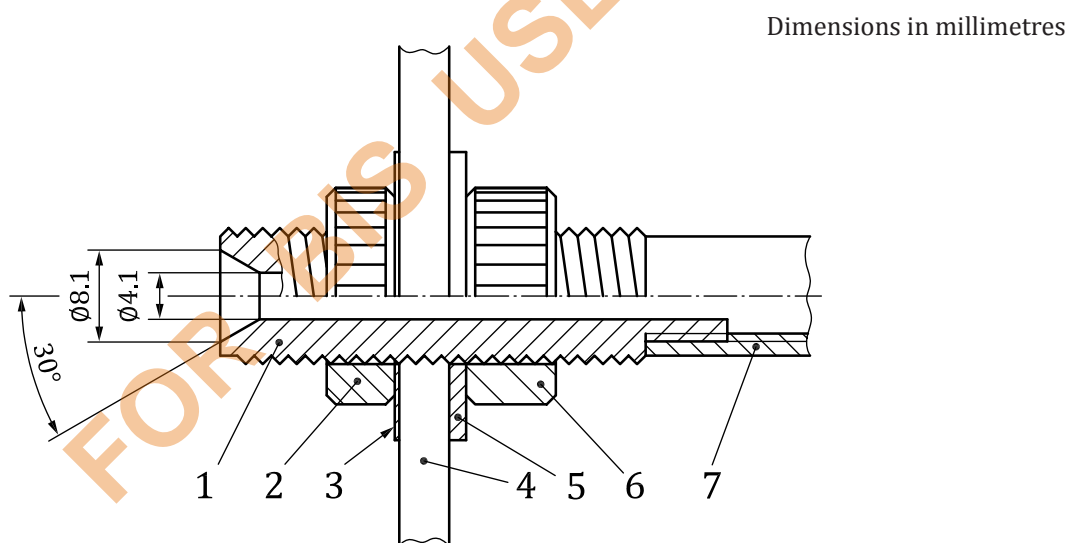

Key

- 1 probe tube
- 2 inner nut
- 3 inner washer
- 4 respiratory interface material
- 5 outer washer
- 6 outer nut
- 7 sampling tube

Figure 5 — Example of sampling probe with chamfer

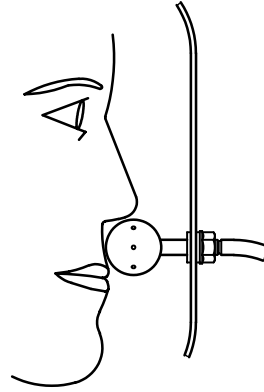

Figure 6 — Example of position of a ball probe used on device with rigid visor

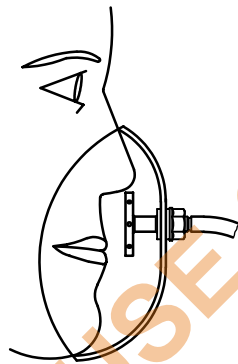
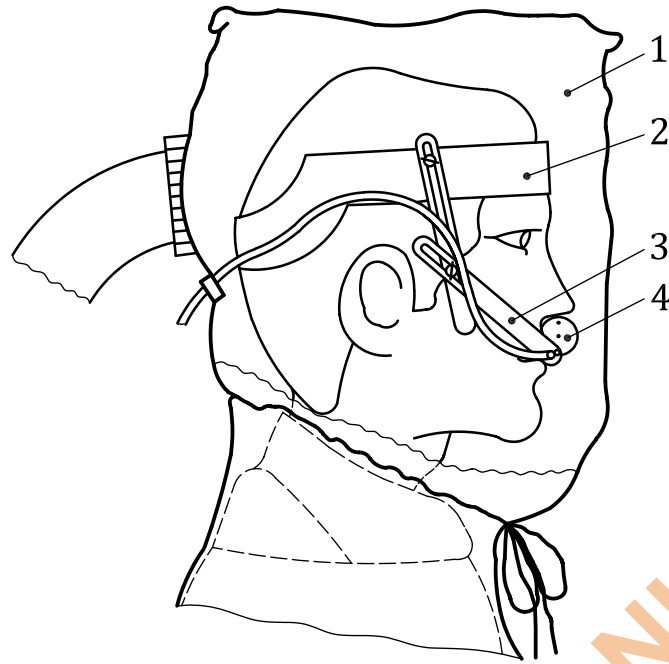

Figure 7 — Example of position of a disc probe used on filtering RPD

FOR BIS USE ONLY



Key

- 1 hood under test
- 2 headband
- 3 adjustable arm
- 4 ball sample probe

Figure 8 — Typical arrangement for sampling from device with soft plastic hoods

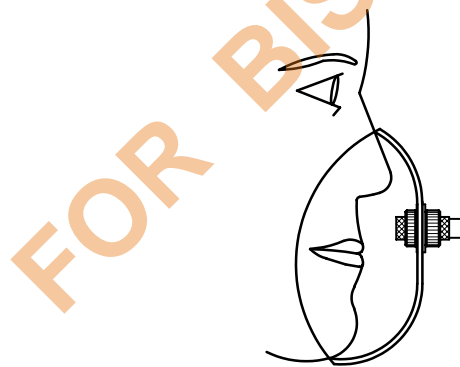

Figure 9 — Example of position of sampling probe with chamfer in filtering RPD

The probe shall be fitted securely to the respiratory interface, terminating as near as possible to the wearer’s face (<10 mm) and preferably midway between the nose and mouth. Where necessary, for flexible, soft, or lightweight respiratory interfaces, employ a means to support the weight of the probe assembly and associated tubing (see [Figure 8](#)) e.g. a head harness, to prevent distortion of the respiratory interface. This distortion can alter the face seal, causing additional leakage.

A second sampling probe (identical to the first) shall be used to measure the ambient concentration of test agent in the test enclosure. This shall be placed close to the RPD, but away from the effect of any exhalation from the RPD under test. The sampling probes shall be connected to the analysing equipment by means of flexible thin-walled tubing of about 3 mm bore, the length of which shall be kept as short as possible. The two sampling tubes shall be of the same type and length.

Where the performance standards require that a sample be withdrawn from the ocular region of the respiratory interface, through which under normal conditions of use there is no airflow, the sampling probe shall be positioned on one side of the test subject at eye level and the compensating air probe shall be positioned on the opposite side of the test subject. See [11.5](#) for details.

Care shall be taken to ensure that the sample tubes and probe do not disturb the normal fit or shape of the respiratory interface.

10.3 Sample flow rates

Sample flow rates shall be between 0,1 l/min and 2 l/min depending on the detection system. The sample flow rate shall be kept as low as possible so as not to change the designed performance of the RPD being tested.

When sodium chloride is used to test negative pressure devices, drying air at a flow of about 1 l/min is added to minimize condensation and hence loss of sodium chloride particles in the sampling tube. The sample flow rate from the respiratory interface is equal to the total flow through the sample pump minus the flow rate of dry air. A correction shall be made for the diluting effect of this dry air when leakage calculations are performed (see [11.3.2.2](#) and [11.3.3.2](#)). Dry air is not required if gas or corn oil aerosol is the test agent.

10.4 Filtering RPD preparation

10.4.1 Unassisted filtering RPD with a connector in accordance with ISO 17420-3

Unassisted RPD incorporating a respiratory interface with a connector in accordance with ISO 17420-3 shall be fitted with the filter simulator as specified in ISO 16900-5, instead of a filter.

Clean breathable air (free of the test agent) shall be supplied (on demand) to the filter simulator via a lightweight hose. It is important that the attachment of the clean air hose to the device does not affect the fit of the device on the test subject. The breathing resistance of the combination of the clean air hose and filter simulator shall be within 10 % of the filter simulator alone when measured at a flow of 110 l/m.

Fitting of the hose shall not replace any seals incorporated in the RPD. If necessary the hose shall be supported.

The test agent(s) to be used shall be chosen in accordance with [Figure 2](#) and [Clause 8](#).

10.4.2 Unassisted filtering RPD fitted with particle filters or combination filters

The complete RPD shall be tested for total inward leakage using an aerosol test agent. However, where the RPD is fitted with a combination filter and the RI is determined to be porous, then two inward leakage test sets shall be performed, one using gas according to test method 1 and the other using aerosol according to either test method 2 or test method 3.

Fit the RPD with the appropriate filter(s) for the specified RPD class.

10.4.3 Unassisted filtering RPD with gas/vapour or combination filters

The test agent(s) to be used shall be chosen in accordance with [Figure 1](#) and [Figure 2](#).

Where the RPD is fitted with a combination filter and the RI is determined to be porous, then two inward leakage test sets shall be performed, one using gas according to test method 1 and the other using aerosol according to either test method 2 or test method 3.

When inward leakage is to be determined using a gas test agent, breathable air (free of the test agent) shall be supplied (on demand) to the filter. For this purpose, lightweight hose(s) and plenum cap(s) shall be attached to the filter element(s) of the test specimen and breathable air (free of the test agent)

supplied to it at a flow resistance (including hoses) within $\pm 10\%$ (when measured at a flow rate of 110 l/min) compared to that measured for the unmodified RPD.

For gas/vapour filters, when total inward leakage is to be determined using an aerosol test agent, replace the gas filters by high efficiency (F5) particle filters. The surrogate replacement particle filters shall have the same mass ($\pm 10\%$) and breathing resistance ($\pm 10\%$), (when measured at a flow rate of 110 l/min), as their gas/vapour counterparts, based on the mean of the supplied filters.

It is important that the attachment of the surrogate filter(s) does not affect the fit of the device, nor shall its fitting replace any seals incorporated in the device.

10.4.4 Assisted filtering RPD with particle filter(s) or combination filter(s)

The complete RPD shall be tested for total inward leakage using an aerosol test agent. However, where the RPD is fitted with a combination filter and the RI is determined to be porous, then two inward leakage test sets shall be performed, one using gas according to test method 1 and the other using aerosol according to either test method 2 or test method 3.

Fit the RPD with the appropriate filter(s) for the specified RPD class.

The RPD shall be tested at the operating conditions as specified in the relevant performance standards. When the performance standards require that the RPD be operated at the minimum designed operating conditions as specified by the manufacturer, these conditions shall be re-created using appropriate means.

NOTE This can require the use of an external power supply, or the use of a modified device supplied by the manufacturer.

10.4.5 Assisted filtering RPD with gas/vapour or combination filter(s)

The test agent(s) to be used shall be chosen in accordance with [Figure 1](#) and [Figure 2](#).

Where the RPD is fitted with a combination filter and the RI is determined to be porous, then two inward leakage test sets shall be performed, one using gas according to test method 1 and the other using aerosol according to either test method 2 or test method 3.

When inward leakage is to be determined using a gas test agent, breathable air (free of the test agent) shall be supplied to the filter. For this purpose, lightweight hose(s) and plenum cap(s) shall be attached to the filter element(s) of the test specimen and breathable air (free of the test agent) supplied to it at a flow resistance (including hoses) within $\pm 10\%$ (when measured at a flow rate of 110 l/min) compared to that measured for the unmodified RPD.

For gas/vapour filters, when total inward leakage is to be determined using an aerosol test agent, replace the gas filters by high efficiency (F5) particle filters. The surrogate replacement particle filters shall have the same mass ($\pm 10\%$) and breathing resistance ($\pm 10\%$), (when measured at a flow rate of 110 l/min), as their gas/vapour counterparts, based on the mean of the supplied filters.

It is important that the attachment of the surrogate filter(s) does not affect the fit of the device, nor shall its fitting replace any seals incorporated in the device.

The RPD shall be tested at the operating conditions as specified in the relevant performance standards. When the performance standards require that the RPD be operated at the minimum designed operating conditions as specified by the manufacturer, these conditions shall be re-created using appropriate means.

NOTE This can require the use of an external power supply, or the use of a modified device supplied by the manufacturer.

10.5 Supplied breathable gas devices

The test agent(s) to be used shall be chosen in accordance with [Figure 1](#) and [2](#).

The RPD shall be tested at the operating conditions as specified in the relevant performance standards. When the performance standards require that the RPD be operated at the minimum designed operating conditions as specified by the manufacturer, these conditions shall be re-created using appropriate means.

10.6 Supplied breathable gas devices incorporating additional filtration facility (combined RPD)

Supplied breathable gas devices which incorporate a filtration facility (combined RPD) shall be tested as complete devices in both modes of operation in accordance with the requirements defined in the performance standards. When tested in supplied breathable gas modes, the filters shall be fitted to the RPD. The filters shall be capped in this mode only if capping is part of this operational mode as specified in the information supplied by the manufacturer. The test agents shall be chosen in accordance with [Figure 1](#) and [2](#).

The devices shall also be tested in the filtration mode using a test aerosol. The device shall be fitted with the appropriate particle filter(s) for the specified RPD class. However, where the RPD is fitted with a combination filter and the RI is determined to be porous, then two inward leakage test sets shall be performed, one using gas according to test method 1 and the other using aerosol according to either test method 2 or test method 3.

The RPD shall be tested at the operating conditions as specified in the relevant performance standards. When the performance standards require that the RPD be operated at the minimum designed operating conditions as specified by the manufacturer, these conditions shall be re-created using a method agreed between the test house and the manufacturer.

11 Test methods

11.1 General

11.1.1 Train the test subjects on how to correctly select and don the device in accordance with the information supplied by the manufacturer.

11.1.2 The test operator shall ensure that the device has been correctly donned in accordance with the information supplied by the manufacturer.

11.1.3 Inform the test subjects that if they wish to adjust the device during the background measurement and acclimatization exercise they can do so. However, no further adjustments are allowed thereafter.

11.1.4 Ensure that the test subjects have no indication of the result as the test proceeds.

11.1.5 Have the subject enter the test enclosure.

11.1.6 Connect up the sampling probe and, if applicable, the clean air supply, the breathing sensor, the differential pressure sensor and compensating air. Operate the device as required in the relevant performance standards.

11.1.7 For NaCl and SF₆, it is necessary to establish a background level within the respiratory interface. Without exposure to the test agent, measure the residual test agent concentration inside the respiratory interface to establish the background level. The test subject shall walk on the treadmill at a speed of 4 km/h until a steady background measurement has been recorded.

11.1.8 Turn on the test atmosphere.

11.1.9 When the test atmosphere has stabilized the test subject shall perform the exercise regime continuously as specified in [Annex B](#).

11.1.10 If required by the relevant performance standards, introduce the 2 m/s crosswind during the appropriate exercise(s).

11.1.11 Record:

- a) enclosure concentration;
- b) the leakage over each exercise period, as defined in [11.2.2](#), [11.3.2.2](#), and [11.3.3.2](#). Although there are two head movements included in exercise 5 and in exercise 7 (see [Tables B.1](#) and [B.2](#)), a single TIL value shall be calculated and recorded for the whole exercise 5 and the whole exercise 7.

11.1.12 When the exercise regime has been completed, the test subject can exit the enclosure. If necessary, turn the test atmosphere off and ensure that the test agent has cleared from the enclosure before the test subject exits the chamber.

11.1.13 When the RPD is to be used for more than one test subject, the device shall be cleaned, disinfected and dried in accordance with the information supplied by the manufacturer. For RPD that is not designed to be cleaned, a new sample shall be used.

11.2 Test method 1: Sulfur hexafluoride (SF₆)

11.2.1 Test equipment

Typical test arrangements are shown in [Figures 10](#) and [11](#).

This method employs SF₆ as a test agent. The test subject wearing the device under test performs a series of test exercises inside an enclosure containing the SF₆ test atmosphere.

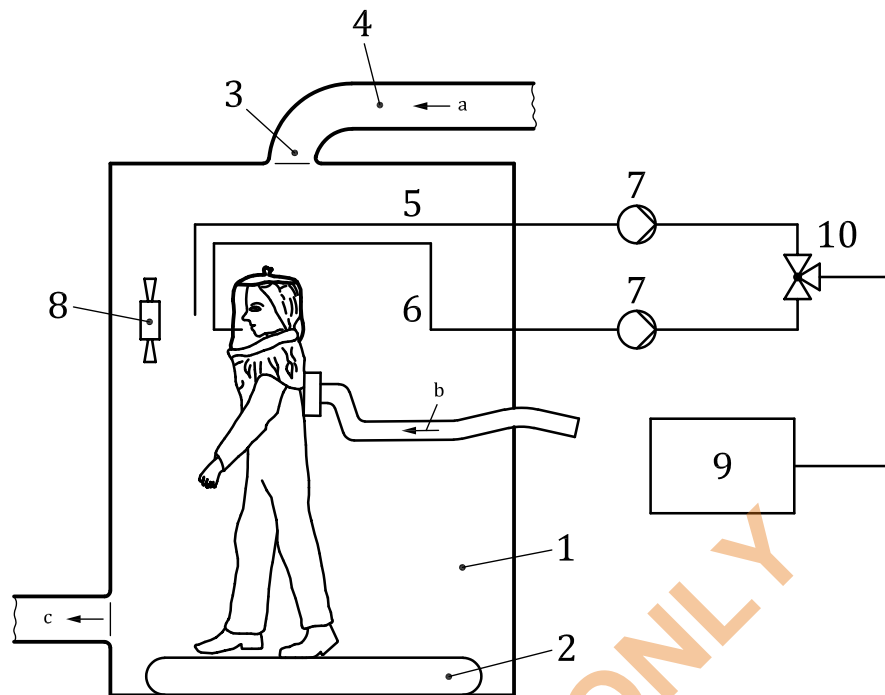
**Key**

- | | |
|--------------------------------|---------------------------------|
| 1 enclosure | 8 circulation fan (if required) |
| 2 treadmill | 9 analyser |
| 3 baffle | 10 change-over valve |
| 4 duct | a Air and SF ₆ . |
| 5 enclosure sample | b Breathable air. |
| 6 respiratory interface sample | c Excess air exhaust. |
| 7 sample pump | |

Figure 10 — Typical test arrangement for determination of inward leakage by the sulfur hexafluoride method with one analyser and change over valve; the figure shows RPD with a respiratory interface type L (loose fitting)

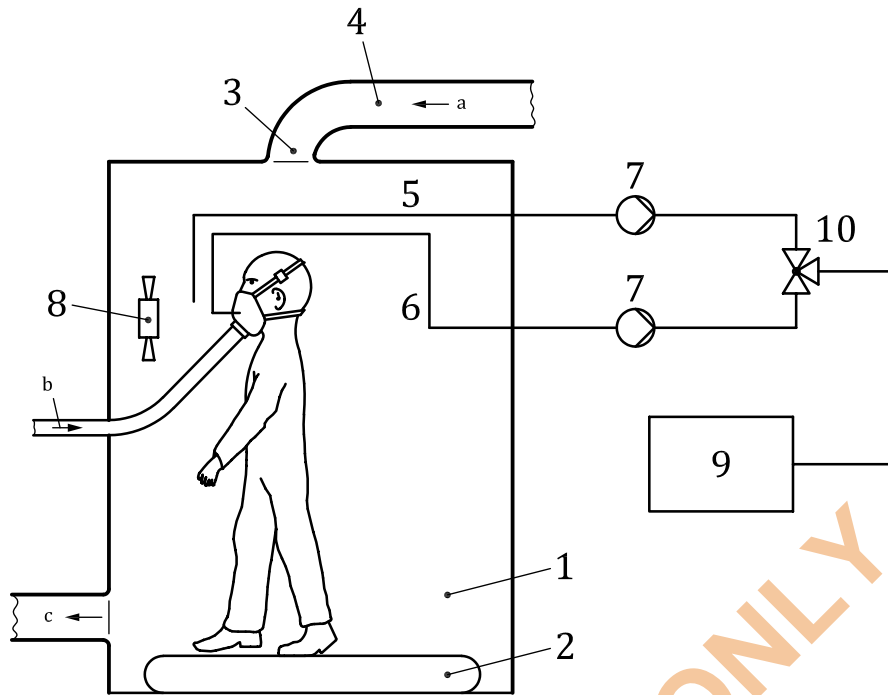

Key

- | | |
|--------------------------------|---------------------------------|
| 1 enclosure | 8 circulation fan (if required) |
| 2 treadmill | 9 analyser |
| 3 baffle | 10 change-over valve |
| 4 duct | a Air and SF ₆ . |
| 5 enclosure sample | b Breathable air. |
| 6 respiratory interface sample | c Excess air exhaust. |
| 7 sample pump | |

Figure 11 — Typical test arrangement for determination of inward leakage by the sulfur hexafluoride method with one analyser and change over valve; the figure shows RPD with a respiratory interface type T (tight fitting)

11.2.1.1 Test gas generation

The gaseous test agent is produced by feeding SF₆ from a compressed gas source into the enclosure's air delivery system. A test agent concentration between 0,1 % and 1 % SF₆ by volume is recommended, starting with a low challenge concentration and increasing it when the results of a preliminary test indicate such a low leakage that higher concentrations are required and can be justified. The variation of the concentration throughout the effective working volume of the enclosure shall be not more than 10 %.

SF₆ with a 99,99 % or higher purity shall be used.

11.2.1.2 Detection

The test agent concentration in the enclosure shall be analysed for SF₆, preferably continuously, by means of a suitable analyser. The SF₆ concentration inside the respiratory interface shall be continuously sampled, preferably with a separate analyser, at a constant sampling rate of between 0,3 l/min and 1,5 l/min and shall be analysed and recorded, preferably using an integrating recording system. This concentration is a measure of the inward leakage.

If a second analyser is not available, the test agent concentration in the enclosure and in the respiratory interface shall be sampled using a single analyser with a change over valve and a separate sampling system. However, time shall then be required to allow the analyser to return to a clean background

before changing over from sampling the test agent concentration in the enclosure to sampling from inside the respiratory interface.

A suitable detection system can be either based on electron capture detection (ECD) or infrared (IR) spectroscopy.

NOTE 1 The ECD instrumentation can be affected by changes in oxygen concentration within the respiratory interface during the test, i.e. the change in oxygen concentration between inhalation and exhalation. These changes can cause uncertainties in the measured leakage when measuring concentrations of $<0,1 \times 10^{-6}$ % by volume. The measured result is intended to be corrected for this change.

NOTE 2 SF₆ is not removed by filters.

11.2.2 Calculation of leakage

Calculate the leakage, P , from measurements made over the last 80 % of each of the exercise periods.

$$P(\%) = \frac{C_2}{C_1} \times 100 \quad (1)$$

where

C_1 is the test agent concentration in the enclosure;

C_2 is the measured mean concentration inside the respiratory interface, corrected for background signal and the effect of oxygen change within the respiratory interface.

11.3 Test method 2: Sodium chloride (NaCl)

11.3.1 Test equipment

11.3.1.1 General

Typical test arrangements are shown in [Figures 12](#) and [13](#).

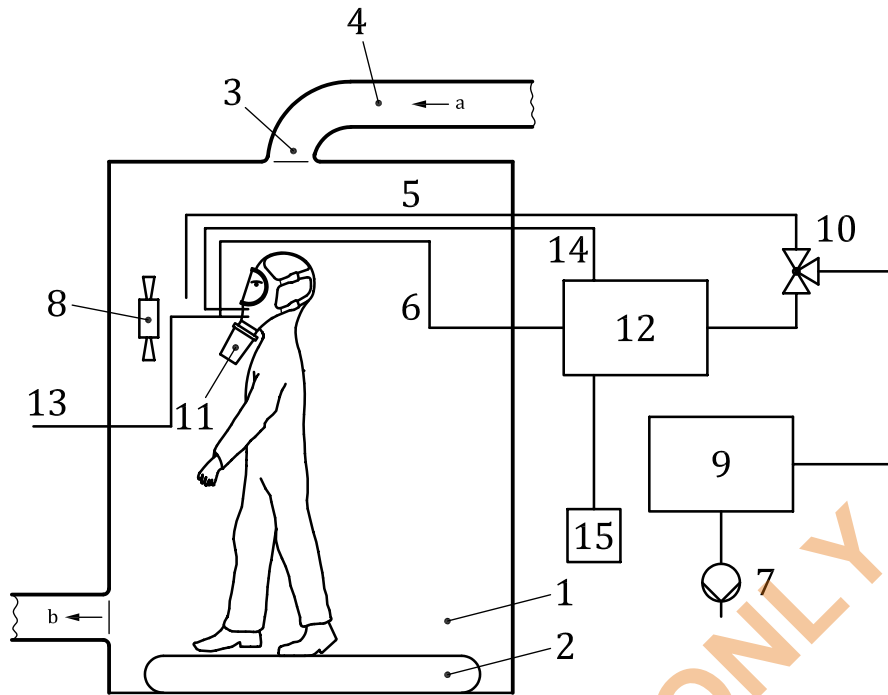

Key

- | | |
|---|---|
| 1 enclosure | 10 change-over valve |
| 2 treadmill | 11 particle filter |
| 3 baffle | 12 pulsed sampling unit |
| 4 duct | 13 dry air flow to sample probe |
| 5 enclosure sample | 14 inhalation/exhalation sensor line |
| 6 respiratory interface sample flow plus dry air flow | 15 particle filter for clean air used during exhale cycle |
| 7 sample pump | a NaCl aerosol. |
| 8 circulation fan (if required) | b Excess air exhaust. |
| 9 photometer | |

Figure 12 — Typical test arrangement for determination of inward leakage by the sodium chloride method (pulsed sampling method) with one analyser and change over valve; the figure shows RPD having a respiratory interface type T (tight fitting)

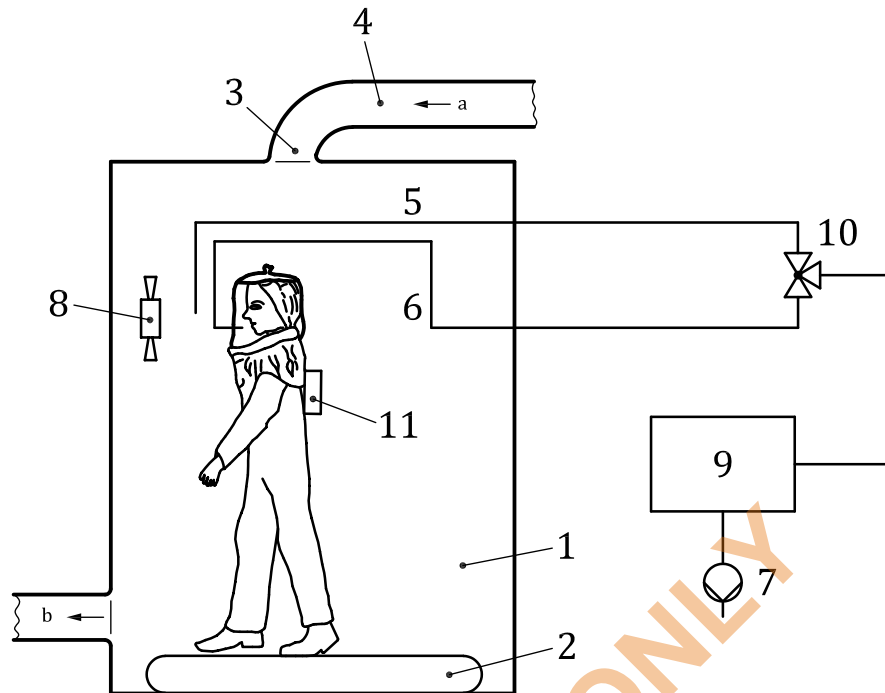
**Key**

- | | |
|--------------------------------|---------------------------------|
| 1 enclosure | 8 circulation fan (if required) |
| 2 treadmill | 9 photometer |
| 3 baffle | 10 change over valve |
| 4 duct | 11 particle filter |
| 5 enclosure sample | a NaCl aerosol. |
| 6 respiratory interface sample | b Excess air exhaust. |
| 7 sample pump | |

Figure 13 — Typical test arrangement for determination of inward leakage by the sodium chloride method (continuous sampling) with one analyser and change over valve; the figure shows RPD having a respiratory interface type L (loose fitting)

This method employs NaCl as the test agent. The test subject wearing the RPD under test performs a series of test exercises inside an enclosure containing the NaCl test agent.

The mean NaCl concentration within the enclosure shall be $(8 \pm 4) \text{ mg/m}^3$ and the variation throughout the effective working volume shall be not more than 10 %.

The particle size distribution shall have a mass median aerodynamic diameter of $0,4 \mu\text{m}$ to $0,7 \mu\text{m}$ and a geometric standard deviation $<2,0$ in the test enclosure.

NOTE Cascade impactor has been found suitable for the determination of the particle size distribution within the chamber.

The test agent concentration is monitored, preferably continuously, during the tests using a separate sampling system to avoid contamination of the respiratory interface sampling lines. It is preferable to use a separate analyser (e.g. photometer) for this purpose.

If a second analyser is not available, the test agent concentration in the enclosure and in the respiratory interface shall be sampled using a single analyser with a change over valve and a separate sampling system. However, time shall then be required to allow the analyser to return to a clean background before changing over from sampling the test agent concentration in the enclosure to sampling from inside the respiratory interface.

It is important that identical sample rates, flow rates for drying air, and additional photometer air (if required) are used for both respiratory interface and enclosure samples in order to directly apply the formulae shown in [11.3.2.2](#) and [11.3.3.2](#).

11.3.1.2 Test aerosol generation

The NaCl aerosol shall be generated from a solution of reagent grade NaCl in distilled water. An example of an atomiser is shown in [Figure 14](#).

The atomizer shall provide a continuous flow of aerosol into a duct through which a constant flow of air is maintained to deliver the aerosol to the enclosure. The diameter and path length of the duct shall be sufficiently large to allow the water content of the aerosol to evaporate, leaving dry NaCl particles. Any bends should be of large radius to minimize loss of NaCl particles. The air within the enclosure shall have a relative humidity of not greater than 60 %. It can be necessary to heat or dehumidify the air in order to obtain complete drying of the aerosol particles.

11.3.1.3 Detection systems

11.3.1.3.1 Flame photometer

A flame photometer is used to measure the concentration of NaCl inside the enclosure and inside the respiratory interface.

The essential performance characteristics for a suitable instrument are set out below.

- a) It shall be a flame photometer specifically designed for the direct analysis of NaCl aerosol.

NOTE The response to elements other than sodium, particularly carbon, the concentration of which will vary during the breathing cycle, can affect the measurement. This effect can be minimized by ensuring that the band pass width of the interference filter is no greater than 3 nm and that all necessary side-band filters are included.

- b) It shall be capable of measuring concentration(s) of NaCl aerosol between 15 mg/m³ and 10 ng/m³.
- c) The total aerosol sample rate required by the flame photometer shall not be greater than 3 l/min.
- d) The response time of the flame photometer, excluding the sampling system, shall not be greater than 500 ms (to 90 % fsd).

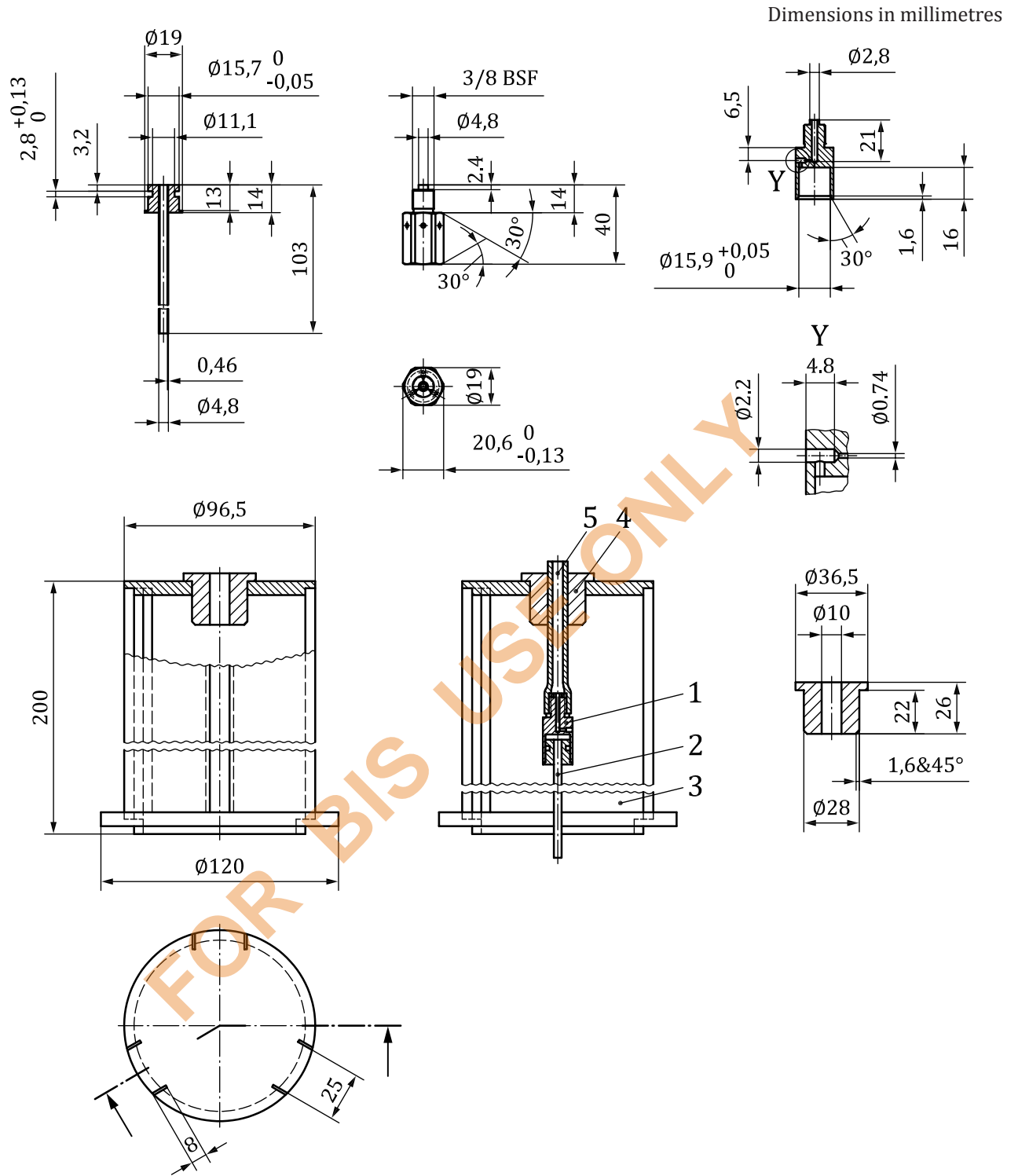

Key

- | | | | |
|---|---------------------------|---|--------------------------------|
| 1 | nozzle | 4 | bush |
| 2 | feed tube (salt solution) | 5 | air tube (10,0 outer diameter) |
| 3 | sleeve | | |

Figure 14 — Example of NaCl atomizer assembly

11.3.1.3.2 Condensation particle counter

The condensation particle counter (CPC) analysis method for sodium chloride aerosol shall be restricted to testing inward leakage with supplied breathable gas devices and filtering devices equipped with high efficiency (F5) filters.

A condensation particle counter is employed to measure the concentration of NaCl particles inside the enclosure and inside the respiratory interface.

The essential performance characteristics for a suitable instrument are set out below.

- a) The instrument shall be capable of counting all particles in the range of 0,010 µm to 1,0 µm diameter.
- b) An air dilution system shall be used to dilute the sample drawn from the chamber to a particle concentration of $(2 \pm 0,2) \times 10^4$ particles/cm³ for the assessment of leakage $\geq 0,01$ %. For the assessment of leakage $< 0,01$ % the dilution shall be adjusted so as to maintain a particle concentration of $(2 \pm 0,2) \times 10^5$ particles/cm³.
- c) The total aerosol sample rate required by the detector shall not be greater than 2 l/min.
- d) The response time of the detector, excluding the sampling system, shall not be greater than 500 ms (to 90 % fsd).

11.3.1.3.3 Sample pump

If no pump is incorporated into the detector, an adjustable flow pump is used to withdraw an air sample. The sample pump shall be placed on the outlet of the detector/photometer. Adjust the pump so as to sample at a constant flow of between 0,1 l/min to 2 l/min. Some types of detectors require a flow rate higher than this sampling flow rate. In these cases, dilute the sample with clean air (free of test agent) accordingly in addition to the drying air introduced into the probe at the sample point.

11.3.2 Pulsed sampling — Method 2A

11.3.2.1 General

A system is required which will switch the sample to the detector only during the inhalation phase of the test subject's respiratory cycle. During the exhalation phase, clean air shall be fed to the detector. The source of this clean air is usually laboratory air at ambient temperature, passed through a particle filter of penetration $< 0,001$ %, shown in [Figure 12](#) as item 15. The essential elements of such a system are:

- a) an electrically operated valve with a response time of the order of 100 ms (it is recommended that the valve should have the minimum possible dead space compatible with straight-through, unrestricted flow when open);
- b) a breathing sensor that is capable of detecting the change from inhalation to exhalation within 30ms. The breathing sensor, which can be either a pressure sensor or a temperature sensor, is connected to a probe fitted in the respiratory interface near the leakage sample probe;
- c) the sensor shall have an adjustable threshold and be capable of differential signalling when the threshold is crossed in either direction. The sensor shall work reliably when subjected to the accelerations produced by the head movements of the test subjects;
- d) an interfacing system to actuate the valve in response to a signal from the breathing sensor;
- e) a timing device to record the proportion of the total respiratory cycle during which sampling occurred.

[Figure 15](#) shows a schematic diagram of such a sampling system (i.e. the elements contained in item 12 of [Figure 12](#)).

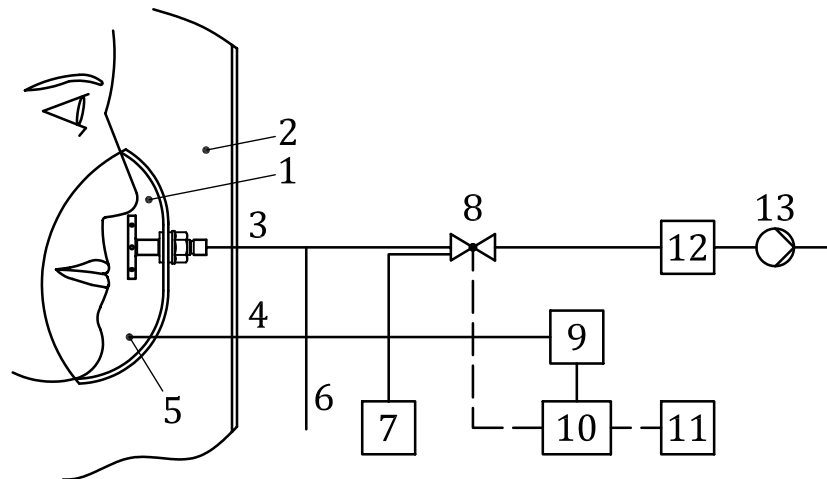
**Key**

1	respiratory interface	8	two-way solenoid valve
2	enclosure	9	differential pressure meter/temperature sensor
3	sample probe line	10	actuator for valve and timer
4	pressure/temperature line	11	timer for % inhalation time of each breathing cycle
5	pressure/temperature probe	12	flame photometer
6	drying air	13	pump
7	high efficiency (F5) particle filter		

Figure 15 — Typical configuration for NaCl pulsed sampling system (Method 2A)

11.3.2.2 Calculation of leakage

Calculate the leakage, P , from measurements made over the last 80 % of each of the exercise periods.

The leakage, P , is the ratio of the concentrations with correction terms for the sampling time and the effects of dilution.

$$P(\%) = \left[\frac{C_2}{C_1} \right] \cdot \left[\frac{t_{in} + t_{ex}}{t_{in}} \right] \cdot \left[\frac{S + D}{S} \right] \cdot 100 \quad (2)$$

where

C_1 is the test agent concentration in the enclosure;

C_2 is the measured mean concentration inside the respiratory interface, corrected for background level;

t_{in} is the total duration of inhalation (s);

t_{ex} is the total duration of exhalation (s);

D is the drying air flow rate (l/min);

S is the respiratory interface sample flow rate (l/min).

Measurement of C_2 is preferably made using an integrating recorder.

11.3.3 Continuous sampling — Method 2B

11.3.3.1 General

In this method air is drawn continuously from the cavity of the respiratory interface throughout the respiratory cycle of the test subject. Since sodium chloride is partially retained in the lungs, it is necessary to apply a correction factor when calculating inward leakage.

11.3.3.2 Calculation of leakage

Calculate the leakage, P , from measurements made over the last 80 % of each of the exercise periods, using [Formula \(3\)](#).

$$P(\%) = 1,25 \cdot \left[\frac{C_2}{C_1} \right] \cdot \left[\frac{S+D}{S} \right] \cdot 100 \quad (3)$$

where

C_1 is the test agent concentration in the enclosure,

C_2 is the measured mean concentration inside the respiratory interface, corrected for background level,

D is the drying air flow rate l/min,

S is the sample flow rate in l/min.

The 1,25 factor is included to allow for lung retention of sodium chloride (it has been derived on the assumption of an air flow rate of the device of 120 l/min and a wearer's breathing rate of 40 l/min).

11.4 Test method 3: Corn oil aerosol

11.4.1 Test equipment

11.4.1.1 General

Typical test arrangements are shown in [Figure 16](#)

This method employs corn oil as a test atmosphere. The test subject wearing the RPD under test performs a series of test exercises inside an enclosure containing the corn oil test atmosphere.

The test agent concentration is monitored, preferably continuously, during the tests using a separate sampling system to avoid contamination of the respiratory interface sampling lines. It is preferable to use a separate detector for this purpose.

An electrostatic classifier is recommended for checking the size distribution of the test aerosol.

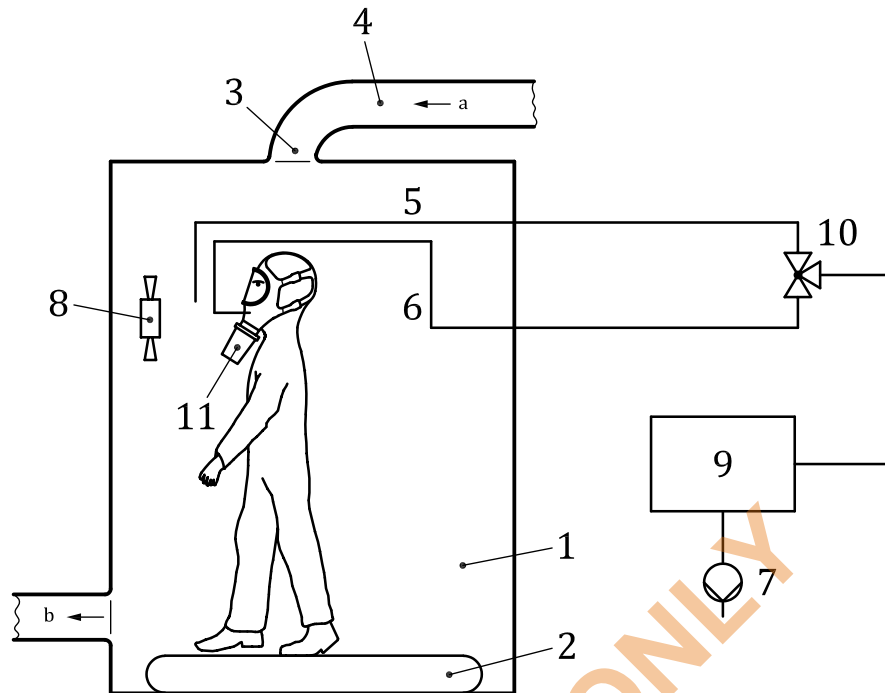
**Key**

- | | |
|--------------------------------|-----------------------|
| 1 enclosure | 8 circulation fan |
| 2 treadmill | 9 analyser |
| 3 baffle | 10 changeover valve |
| 4 duct | 11 particle filter |
| 5 enclosure sample | a Corn oil aerosol. |
| 6 respiratory interface sample | b Excess air exhaust. |
| 7 sample pump | |

Figure 16 — Typical test arrangement for determination of inward leakage by the corn oil method (continuous sampling) with one analyser and change over valve; showing a RPD with a class cT respiratory interface

11.4.1.2 Test aerosol generation

The test aerosol is generated by atomising the corn oil using compressed air. Corn oil utilised shall comply with Chemical Abstract No. 8001-30-7.

The aerosol generator shall be capable of generating and maintaining a concentration of corn oil test aerosol within the range of 20 mg/m³ to 40 mg/m³ with a mass median aerodynamic diameter (MMAD) of 0,4 µm to 0,7 µm and a geometric standard deviation of <2,0 in the test enclosure.

The equipment shall be capable of operation without using recycled air.

11.4.1.3 Detection

An aerosol measurement system is used to measure the concentration of the corn oil aerosol inside the enclosure and inside the respiratory interface. Application of a diluter on the enclosure sample can be used to reduce the challenge concentration to levels within the detection range of the device. The minimum limit of detection should be <0,01 mg/m³.

NOTE A suitable aerosol measurement system is one based on light scattering laser photometers. Other detection methods can be used provided that equivalence can be demonstrated.

If a second analyser is not available, the test agent concentration in the enclosure and in the respiratory interface shall be sampled using a single analyser with a change over valve and a separate sampling system. However, time shall then be required to allow the analyser to return to a clean background before changing over from sampling the test agent concentration in the enclosure to sampling from inside the respiratory interface.

11.4.1.4 Calculation of leakage

Calculate the leakage, P , from measurements made over the last 80 % of each of the exercise periods using [Formula \(4\)](#).

$$P(\%) = \frac{C_2}{C_1} \times 100 \quad (4)$$

where

C_1 is the test agent concentration in the enclosure,

C_2 is the measured mean test agent concentration inside the respiratory interface, corrected for background level.

11.5 Determination of inward leakage in the ocular zone

The ocular zone of the respiratory interface shall be fitted in a leaktight manner with three probes to enable sample removal, compensating air addition and pressure measurement.

The sampling probe shall be positioned inside the Respiratory Interface on one side of the test subject at eye level. The port for compensating air shall be positioned on the other side slightly displaced from eye level, so that the test subject will not be distressed by the pressure compensating air flow. In the middle between the ports for the sampling probe and compensating air, a third probe shall be connected to a sensitive differential pressure meter (sensitivity $\leq 0,1$ mbar).

A continuous sample flow rate of not greater than 1,0 l/min shall be fed through the sampling line to the challenge detector and, if necessary, shall be diluted with clean air to achieve the minimum flow rate required by the detector. Clean air shall be fed through the compensating air probe at a flow necessary to ensure that the pressure in the Respiratory Interface is not altered by the sampling procedure. This measurement shall be made while the test subject is standing without any movement and it may be necessary for the test subject to hold their breath during this procedure.

12 Test report

The test report shall include information regarding those parameters specified in [Clause 4](#), together with the following, as a minimum:

- a) identification of the RPD;
- b) bivariate cell number to which each test subject has been allocated;
- c) the arithmetic mean percentage inward leakage for each exercise for each individual test subject;
- d) the arithmetic mean percentage inward leakage for the whole test exercise regime for each individual test subject;
- e) the identification of the test sample used by each individual test subject;
- f) the second highest value in the data set in d);
- g) the test method used and a statement of the corresponding leakage range that can be accurately measured with this method;

h) the uncertainty of the measurements made.

For combined and multi-functional RPD, test exercise number 11 (see [Table B.4](#)) shall be included in the calculation for arithmetic mean of the whole exercise regime.

13 Uncertainty of measurement

An estimate of the uncertainty of measurement associated with this method of test shall be established, in accordance with ISO 21748. The value of this estimate shall not exceed $\pm 10\%$.

NOTE The use of transfer standards can assist in establishing common uncertainties of measurement between laboratories.

FOR BIS USE ONLY

Annex A (normative)

Application of uncertainty of measurement — Determination of compliance

In order to determine compliance or otherwise of the measurement made in accordance with this test method, the following protocol shall be applied.

If the test result \pm the uncertainty of measurement, U , falls completely inside or outside the specification zone for the particular test given in the performance standards, then the result shall be deemed to be a straightforward pass or fail (see [Figures A.1](#) and [A.2](#)).

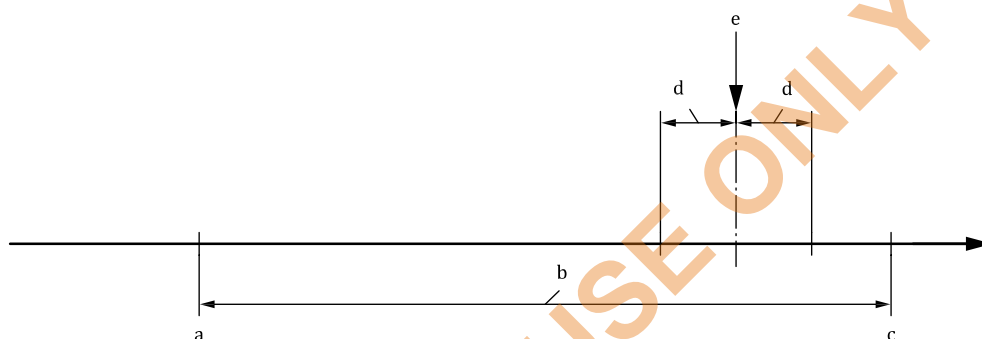

- a Lower specification limit.
- b Specification zone.
- c Upper specification limit.
- d Uncertainty of measurement, U .
- e Measured value.

Figure A.1 — Result pass

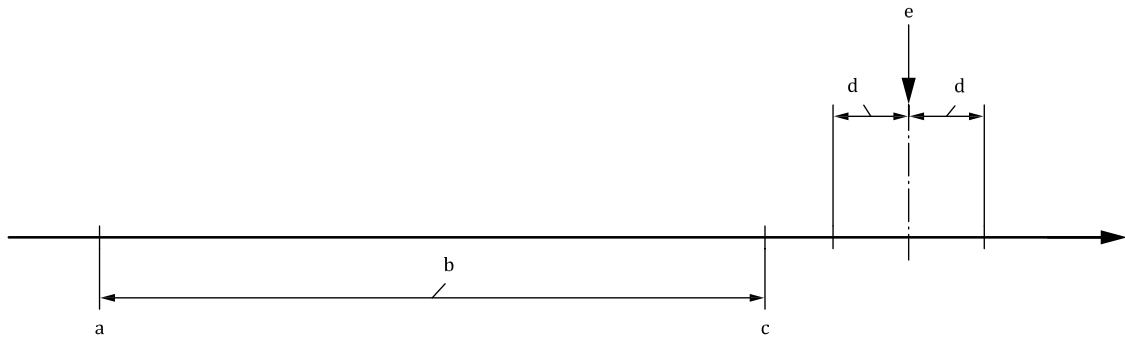

- a Lower specification limit.
- b Specification zone.
- c Upper specification limit.
- d Uncertainty of measurement, U .
- e Measured value.

Figure A.2 — Result fail

If the test result \pm the uncertainty of measurement, U , overlaps a specification limit value (upper or lower) for the particular test given in this standard, then the assessment of pass or fail shall be determined on the basis of safety for the wearer of the RPD; that is, the result shall be deemed to be a fail (see [Figure A.3](#)).

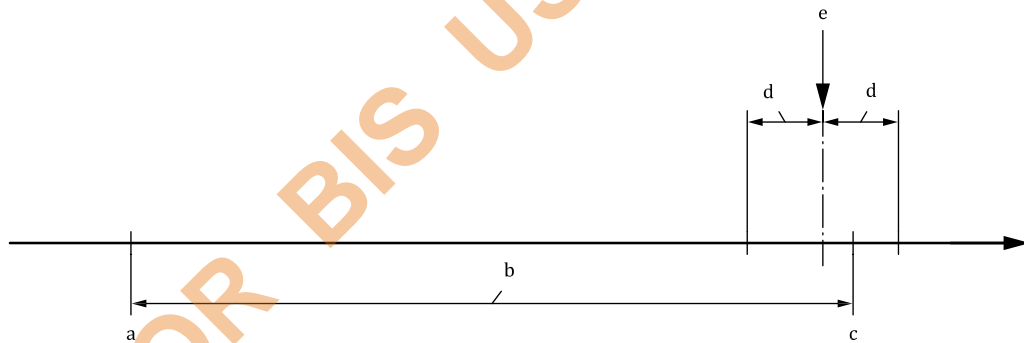

- a Lower specification limit.
- b Specification zone.
- c Upper specification limit.
- d Uncertainty of measurement, U .
- e Measured value.

Figure A.3 — Result fail

Annex B (normative)

Test exercise regime

B.1 General

- a) The leakage measurements recorded during the acclimatization exercise shall not be used in the determination of inward leakage.
- b) The concentration within the sample zone shall be measured continuously throughout the whole exercise period, but only the last 80 % of the exercise period shall be used in the determination of inward leakage.
- c) Movements within each particular exercise shall be equally distributed over the time of that exercise.
- d) The exercises shall be done in a continuous manner without a rest period between each exercise.

NOTE Switching between most exercises happens almost immediately, but in certain situations (for example between exercises 5 and 6 in [Table B.1](#)) it might be necessary for the test operator to determine when the next exercise has begun.

- e) The performance standards can permit exclusions of specific test exercises, e.g. talking for RPDs that incorporate a mouthpiece.
- f) The treadmill shall be set to an inclination of 0 % unless specified otherwise by the performance standards.
- g) For RPD not having a long enough service time e.g. escape RPD, the test regime shall be terminated at the end of the service life and resumed with another RPD, starting with the acclimatization and then from the last completed exercises. Repeat as many times as necessary in order to complete the regime.
- h) For combined or multifunctional RPD, the additional test exercise shown in [Table B.4](#) shall be completed following the standing still exercise (test exercise number 10 in [Table B.2](#), or test exercise number 9 in [Table B.1](#), respectively).

B.2 Test exercises

Use the test exercise regimes in [Tables B.1](#), [B.2](#), [B.3](#) and [B.4](#) as directed by the performance standards

Table B.1 — Exercise regime 1

Exercise number	Crosswind for type L RPD	Test exercise
1		Acclimatization Walking upright on a treadmill at a speed of 4 km/h for 3 min.
NOTE For exercises 6, 7, and 8, the crosswinds as specified in 11.1.10 is intended to be used.		
^a The equivalent text in other languages is chosen such that it covers the range of facial movements observed during talking. The English rainbow passage text was chosen because it covers the range of facial movements. If possible, it is desirable to choose a text with sentence and phrase lengths that are similar to the rainbow passage.		

Table B.1 (continued)

Exercise number	Crosswind for type L RPD	Test exercise
2		Standing still Standing still, upright, without movement of the head, and without speech for 2 min.
2a		Hydration (if the device incorporates a hydration facility) While standing still, operate the hydration facility (see Table B.3) twice over a minimum of a 1 min period, but if necessary extend the time of the exercise to permit two sequences to be conducted. Follow the manufacturer's procedures when conducting the steps given in Table B.3 , ensuring that the hydration facility is fully stowed away on the respiratory interface at the start and the end of the procedure.
3		Reach up and down While standing and without speaking, reaching arms up above head, looking up, then down to floor looking down, 15 times over 2 min.
4		Squatting With both feet together, fully bending knees ten times within 1 min, without head movement.
5		Hands and knees, head rotation While on hands and knees and without speaking, rotate head from one side to the other for 1 min (approximately 10 times), and then up and down for 1 min (approximately ten times). Total time: 2 min.
6	✓	Walk Walking upright on a treadmill at a speed of 5,5 km/h without movement of the head and without speech for 2 min.
7	✓	Walk, head rotation Walking upright and without speaking on a treadmill at a speed of 5,5 km/h with rotation of the head from one side to the other for 70 s (approximately ten times/min), then up and down for 50 s (approximately ten times/min). Total time: 2 min.
8	✓	Walk, speaking Walking upright on treadmill at a speed of 5,5 km/h, read aloud, (as if communicating with a colleague), the rainbow passage ^a or equivalent text passage for 2 min.
9		Standing still Standing still, upright, without movement of the head, and without speaking for 2 min.
		Test schedule duration: 18 min (19 min optional).
NOTE For exercises 6, 7, and 8, the crosswinds as specified in 11.1.10 is intended to be used.		
^a The equivalent text in other languages is chosen such that it covers the range of facial movements observed during talking. The English rainbow passage text was chosen because it covers the range of facial movements. If possible, it is desirable to choose a text with sentence and phrase lengths that are similar to the rainbow passage.		

Table B.2 — Exercise regime 2

Exercise number	Crosswind for type L RPD	Test exercise
1		Acclimatization Walking upright on a treadmill at a speed of 4 km/h for 3 min.
2		Standing still Standing still, upright, without movement of the head, and without speech for 2 min.
2a		Hydration (if the device incorporates a hydration facility) While standing still, operate the hydration facility (see Table B.3) twice over a minimum of a 1 min period, but if necessary extend the time of the exercise to permit two sequences to be conducted. Follow the manufacturer's procedures when conducting the steps given in Table B.3 , ensuring that the hydration facility is fully stowed away on the respiratory interface at the start and the end of the procedure.
3		Reach up and down While standing and without speaking, reaching arms up above head, looking up, then down to floor looking down, 15 times over 2 min.
4		Squatting With both feet together, fully bending knees ten times within 1 min, without head movement.
5		Hands and knees, head rotation While on hands and knees and without speaking, with rotation of the head from one side to the other for 1 min (approximately ten times), and then up and down for 1 min (approximately ten times). Total time: 2 min.
6	✓	Walk Walking upright on a treadmill at a speed of 5,5 km/h without movement of the head, and without speech for 2 min.
7	✓	Walk, head rotation Walking upright and without speaking on a treadmill at a speed of 5,5 km/h with rotation of the head from one side to the other for 70 s (approximately ten times/min), then up and down for 50 s (approximately ten times/min). Total time: 2 min.
8	✓	Walk, speaking Walking upright on treadmill at a speed of 5,5 km/h, read aloud, (as if communicating with a colleague), the rainbow passage ^a or equivalent text passage for 2 min.
9		Hop While standing on a stationary treadmill, hop on one leg five times. The foot shall clearly separate from the floor with each hop. Rest for approximately 10 s, change leg, and hop a further five times. Rest until the beginning of second minute. Repeat hopping exercise. Rest until the end of the second minute. (The use of a support rail to maintain balance during hopping is acceptable.)
10		Standing still Standing still, upright, without movement of the head, and without speaking for 2 min.

NOTE For exercises 6, 7, and 8, the crosswinds as specified in [11.1.10](#) is intended to be used.

^a The equivalent text in other languages is chosen such that it covers the range of facial movements observed during talking. The English rainbow passage text was chosen because it covers the range of facial movements. If possible, it is desirable to choose a text with sentence and phrase lengths that are similar to the rainbow passage.

Table B.2 (continued)

Exercise number	Crosswind for type L RPD	Test exercise
10A		<p>Change over (applies only to combined or multifunctional RPD)</p> <p>Conduct the exercise described in Table B.4</p> <p>Wait for 15 s and set the device to the alternative mode of operation (if not already in the alternative mode). Repeat actions 2 to 10.</p>
		Test schedule duration: 20 min plus time for optional testing.
<p>NOTE For exercises 6, 7, and 8, the crosswinds as specified in 11.1.10 is intended to be used.</p> <p>^a The equivalent text in other languages is chosen such that it covers the range of facial movements observed during talking. The English rainbow passage text was chosen because it covers the range of facial movements. If possible, it is desirable to choose a text with sentence and phrase lengths that are similar to the rainbow passage.</p>		

Table B.3 — Hydration

Test exercise
Undo the hydration link from its stowage port on the respiratory interface.
Remove water carrier from its pouch.
Remove water carrier protective stopper.
Hold carrier up close to respiratory interface.
Securely attach hydration port on respiratory interface link to water carrier port.
If fitted, open hydration valve to bring internal mouthpiece in line with mouth.
Hold water carrier upside-down above eye level.
Blow into carrier to pressurize, allowing water to flow into mouth.
Drink as required, ensuring that canteen is slightly pressurized to make drinking easier.
Once drinking is complete, lower water carrier, and blow through drinking straw to clear of water.
Close hydration valve (if fitted) to stow internal drinks tube.
Stow the external drink hydration link tube on respiratory interface stowage port.
Re-fit water carrier protective stopper.
Stow carrier in pouch on waist belt, if equipped.

Table B.4 — Combined or multifunctional RPD change-over exercise

Exercise number	Test exercise
11	While standing on a stationary treadmill, the combined or multifunctional RPD shall be set from one mode of operation to the other; and after 1 min, back to the original configuration (if compatible with the design)

Annex C (informative)

Material porosity test

C.1 Principle

This test serves the purpose of determining, particularly in case of doubt, which method shall be used for the determination of inward leakage. A specified air pressure is applied to the material of the respiratory interface and/or its seal to the wearer, which is wetted by a liquid and has a film of the same liquid applied to its upper surface. If bubbles escape continuously from the upper surface, the material is rated as porous and the sulfur hexafluoride method is to be used. If no bubbles escape continuously, the sulfur hexafluoride and aerosol methods are equally acceptable options.

C.2 Material porosity test apparatus

C.2.1 Test fixture.

The test fixture is shown as [Figure C.1](#).

A cylindrical vessel of 50 mm to 90 mm inner diameter, depending on the size of specimen to be evaluated, over which the test specimen is sealed by a clamping mechanism. The fixture can be fitted with a gasket to ensure a seal against the test specimen.

C.2.2 Test liquid.

1 l of water in which a few drops of wetting agent (softener or washing-up liquid) are dissolved.

C.2.3 Pressure measuring device.

C.2.4 Air supply and control valves.

C.3 Preparation of test specimens

Sufficient specimens shall be cut from the RPD so that an assessment can be made of all materials and seams. The specimens shall be large enough to cover the test fixture.

C.4 Procedure

Soak the test specimen under approximately 15 mm of test liquid for a period of not less than 3 min. Remove the test specimen from the test liquid and clamp it in the test fixture. Pour sufficient test liquid on to the surface of the test specimen to form a continuous film. Apply air pressure to the under surface of the test specimen until bubbles escape, or up to a maximum of 100 mbar, whichever occurs first. If any bubbles escape from the upper surface of the test specimen, the material is considered to be porous. Repeat the test with the other test specimens (see [C.3](#)).

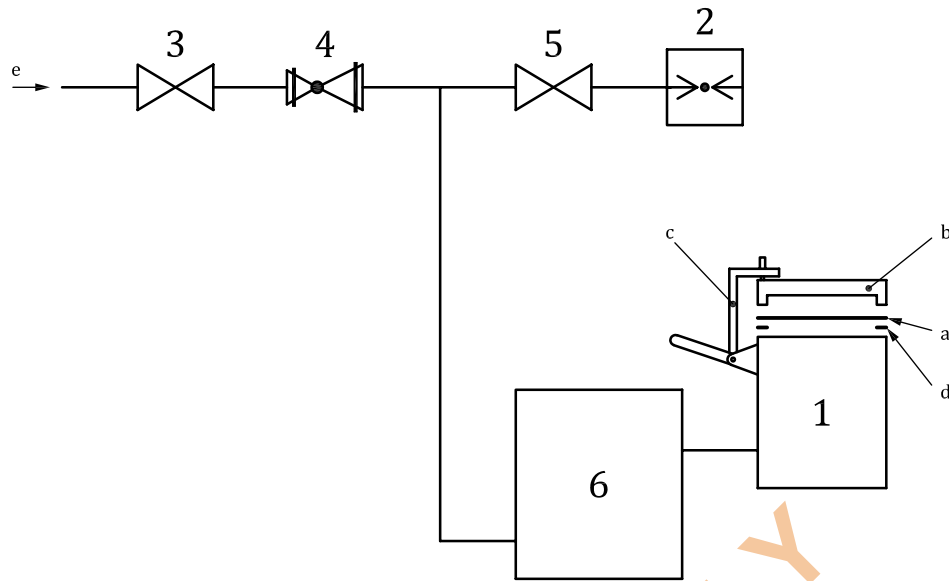

Key

- 1 test fixture
- 2 pressure measuring device
- 3 stop-valve A
- 4 variable flow valve
- 5 stop-valve B
- 6 air reservoir
- a Test specimen.
- b Clamping ring.
- c Clamp.
- d Gasket.
- e Air supply.

NOTE 1 The test fixture is a cylindrical vessel over which the specimen is clamped by a clamping ring and clamp. It is fitted with a gasket to make a seal against the specimen.

NOTE 2 The stop-valve A serves to direct air to the test fixture.

NOTE 3 The variable flow valve is set to give the required rate of rise of pressure in the test fixture.

NOTE 4 The stop-valve B directs air to the pressure measuring device.

NOTE 5 The air reservoir of about 2,5 l capacity is connected to the test fixture. This ensures that the flow rate of air necessary to ensure the pressure remains constant so that the loss of air through the test specimen when bubbling begins will not seriously reduce the rate of rise of pressure.

Figure C.1 — Typical test arrangement for the determination of porosity

Annex D (informative)

Preparation and use of bivariate test panel

The bivariate test panel is based on face length and face width. The face measurements are described in ISO/TS 16976-2:2015, Annex B, measurements B (face width) and measurement D (menton-sellion). The panel is divided into ten cells (see [Figure D.1](#)).

The panel covers 96,7 % of males and 98,7 % females of the selected population. It has limits of 98,5 mm to 138,5 mm for face length and 120,5 mm to 158,5 mm for face width. These limits are based on measurements of the male mean plus two standard deviations (SDs) and the female mean minus two SDs. Cell boundaries are adjusted so that the target population can be distributed among cells as uniformly as possible. The boundaries are set so that at least 95 % of the target population is included in the panel.

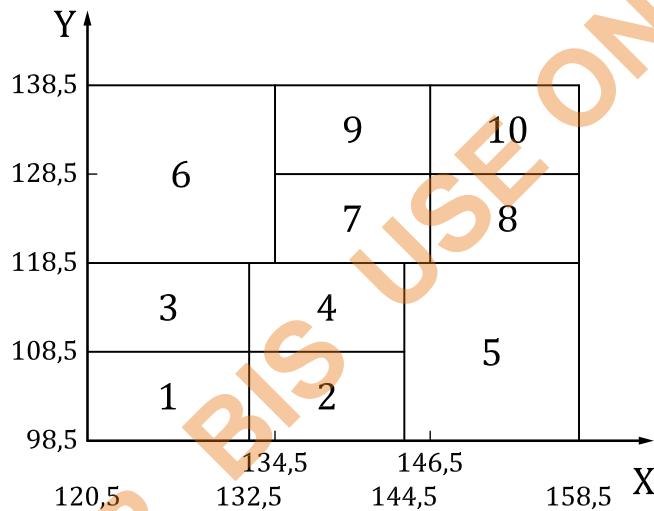

Key
 X face width, in millimetres
 Y face length, in millimetres

Figure D.1 — Bivariate panel based on face length and face width

The selection of cells and the distribution of test subjects within the selected cells depends on the size of the RI under test. Where one size of RI is submitted by the manufacturer to fit all head sizes, the subjects shall be distributed among all cells such that there is at least one subject from each cell. Where multiple sizes of RI are submitted for test, or where the RI is defined by the manufacturer as fitting a section of the target population (eg small faces only) then the distribution of the test subjects among the relevant cells shall be agreed between the test house and manufacturer.

Bibliography

- [1] JCGM 100, *Evaluation of measurement data — Guide to the expression of uncertainty in measurement*, available at: <http://www.bipm.org/en/publications/guides/gum.html>

FOR BIS USE ONLY

FOR BIS USE ONLY