

प्राकृतिक प्रवात काउंटर प्रवाह कूलिंग
टावरों के थर्मो-द्रवचालित डिज़ाइन —
दिशानिर्देश

Thermo-Hydraulic Design of Natural
Draught Counter Flow Cooling
Towers — Guidelines

ICS 27.060.30

© BIS 2024



भारतीय मानक ब्यूरो
BUREAU OF INDIAN STANDARDS
मानक भवन, 9 बहादुर शाह ज़फर मार्ग, नई दिल्ली - 110002
MANAK BHAVAN, 9 BAHADUR SHAH ZAFAR MARG
NEW DELHI - 110002
www.bis.gov.in www.standardsbis.in

FOREWORD

This Indian Standard was adopted by the Bureau of Indian Standards, after the draft finalized by the Special Structures Sectional Committee had been approved by the Civil Engineering Division Council.

This standard on the thermo-hydraulic design of natural draught counterflow cooling towers (NDCTs) is published for the benefit of the entire cooling tower industry and all those who have an interest in the field.

Unlike induced draught cooling towers (IDCTs), NDCTs are complex in terms of thermal as well as civil designs. NDCT thermal design is not straight forward as it is with IDCTs since the draught generated is not controlled mechanically but occur due to weather phenomena involving wind speed, adiabatic lapse rate, ambient air pressure, etc. There are not many guidelines world over (except may be, for some old publications that are out of circulation) that enumerate all the steps involved in the estimation number of transfer units (NTU) and pressure drops for the thermal design of NDCTs. One needs to refer to the many research papers and books available in public domain for understanding the technology involved. However, the technology is not easy to understand for people outside the field and hence, has evoked little interest in end users/purchasers so far.

Keeping these aspects in mind, the Committee is mandated to bring out some guidelines that take reference from multiple publications and compile the thermal design process in such a way that it is easily understood by the purchaser and also designers new to the field. In the process, the complex mathematical equations and iterative calculations have been reduced to simple linear equations (on par with IDCT design method) so that the methodology described is appreciated and uniformly followed by all the cooling tower designers and purchasers for the overall benefit of the industry and the environment in the country.

Though one may consider the designs resulting from this guideline as a minimum requirement, designers will be required, and so are encouraged, to make additional project specific considerations as may be applicable to result in performing cooling towers for the overall benefit of the industry and also the environment.

Most of the simplified calculation method described is taken from research papers of R. F. Rish and H. Chilton. All parameters are converted from FPS system to SI system for easy understanding and to meet the requirements of IS codes.

For better understanding, solved examples for thermic design of NDCT with fresh water circulation and with sea water circulation are given in [Annex B](#) and [Annex C](#).

In the formulation of this standard due weightage has been given to international coordination among the standards and practices prevailing in different countries in addition to relating it to the practices in the field in this country. This has been met by deriving assistance from the following publications:

BS 4485-2 'Water cooling towers — Part 2: Methods for performance testing', British Standards Institution

BS 4485-3 'Water cooling towers — Part 3: Code of practice for thermal and functional design', British Standards Institution

BS EN 14705 : 2005 'Heat exchangers method of measurement and evaluation of thermal performances of wet cooling towers', British Standards Institution

CTI ATC 105 : 2022 'Acceptance test code for cooling towers', Cooling Technology Institute, Houston

CTI Blue Book, Demand curves for counterflow cooling towers, Cooling Technology Institute, Houston

Cooling tower performance prediction and improvement, Volume 1, Applications Guide, Electric Power Research Institute

Design of a Natural Draught Cooling Tower by R. F. Rish

Performance of Natural Draught Water-Cooling Towers by H. Chilton

(Continued on third cover)

CONTENTS

1 SCOPE	1
2 REFERENCES	1
3 TERMINOLOGY	1
4 SYMBOLS AND UNITS	1
5 NATURAL DRAUGHT COUNTERFLOW COOLING TOWER	2
5.1 Configuration and Components	3
5.2 Heat Transfer Process	11
5.3 Specifying Thermal Design Duty	12
5.4 Thermal Design Method	14
5.5 Design Optimization	15
5.6 Hydraulic Design	16
5.7 Tower Performance	17
ANNEX A PRESSURE DROP CALCULATIONS	18
ANNEX B SOLVED EXAMPLE OF A NDCT THERMIC DESIGN FOR FRESH WATER APPLICATION	20
ANNEX C SOLVED EXAMPLE OF A NDCT THERMIC DESIGN FOR SEA WATER APPLICATION	28
ANNEX D COMMITTEE COMPOSTION	37

*Indian Standard***THERMO-HYDRAULIC DESIGN OF NATURAL DRAUGHT
COUNTER FLOW COOLING TOWERS — GUIDELINES****1 SCOPE**

1.1 This guideline covers thermo-hydraulic design aspects of natural draught counterflow cooling towers (NDCTs).

1.2 This guideline covers the uniform air-water loading method of design and does not cover the non-uniform air-water loading method of design.

1.3 This standard excludes the provisions under Thermo-hydraulic design of induced draught counterflow cooling towers (IDCTs), IS 18758.

2 REFERENCES

The standards given below contain provisions, which through reference in this text constitute provisions of this standard. At the time of publication, the editions indicated were valid. The standard is subject to revision and parties to agreement based on this standard are encouraged to investigate the possibility of applying the most recent edition of these standards:

<i>IS No.</i>	<i>Title</i>
IS 2405 (Part 1) : 1980	Specification for industrial sieves: Part 1 Wire cloth sieves (<i>fourth revision</i>)
IS 18758 : 2024	Thermo-hydraulic design of induced draught counterflow cooling towers — Guidelines

3 TERMINOLOGY

3.1 Air Inlet — Air inlet is the open face of the NDCT between the basin kerb level and the shell bottom through which air is sucked into the tower by the natural draught.

3.2 Cold Water Channel (CWC) — Cold water channel (CWC) is an outlet from where re-cooled water flows out of the basin toward the fore bay of a pump house.

3.3 Distribution System — The distribution system in a NDCT comprises of hot water channels/ducts, distribution pipes and spray nozzles.

3.4 Drift Eliminator — Drift Eliminators are used in cooling towers to eliminate drift, that is, water particles/droplets being carried away by the up draught of air.

3.5 Fill or The Heat Transfer Media — The ‘fill’ or the heat transfer media is the packing inside the NDCT over which hot water is sprayed by nozzles to exchange heat with the upward draught of air.

3.6 Rain Zone — Rain zone is the space between the bottom of fill and the water surface in the basin. Droplets of water falling through the fill are called ‘rain’.

3.7 Shell Exit Diameter — It is the diameter of the shell at the top.

3.8 Throat Diameter — The throat diameter is the narrowest portion of the hyperboloid.

3.9 Top Platform — It is the platform at the top of the shell for access to aviation obstruction lights and lightning arrestors.

3.10 Vena Contracta — Vena contracta is the narrowing of the air flow after it exits the fill.

3.11 Wind Baffle — Wind baffle is a wall provided inside the NDCT to prevent ambient wind blowing at increased speeds from affecting the thermal performance.

4 SYMBOLS AND UNITS

For the purpose of this standard, the following letter symbols shall have the meaning indicated against each; where other symbols are used, they are explained at the appropriate places:

<i>Symbol</i>	<i>Description</i>
<i>A</i>	- Pond area (at sill)
<i>C</i>	- Performance coefficient for the NDCT
<i>C_p</i>	- Specific heat of water
<i>DBT</i>	- Dry bulb temperature
<i>E_v</i>	- Evaporation loss
<i>EMSL</i>	- Elevation above mean sea level

To access Indian Standards click on the link below:

https://www.services.bis.gov.in/php/BIS_2.0/bisconnect/knowyourstandards/Indian_standards/isdetails/

<i>Symbol</i>	<i>Description</i>	<i>Symbol</i>	<i>Description</i>
FH	- Fill height or fill depth	t_2	- Exit wet bulb temperature
F_{rd}	- Froude number	WBT	- Wet bulb temperature
G	- Dry air mass flow per unit fill area	WL	- Water loading
H	- Air inlet height	α	- Merkel number
H_d	- Draught height (measured from the mid level of fill)	Δp	- Pressure difference/pressure drop
H_{Tower}	- Total height of NDCT ($H_d + H + FH/2$)	$\Delta \rho$	- Density difference
h_w	- Enthalpy of air film in contact with hot water	θ	- Shell angle
h_1	- Enthalpy of inlet (ambient) air	v_{ai}	- Velocity of air through inlet
h_2	- Enthalpy of air exiting the fill	v_{ao}	- Velocity of air through outlet
KaV/L	- Tower characteristic or number of transfer units (NTU)	v_{fill}	- Velocity of air through fill
L	- Water mass flow per unit fill area	ρ_{avf}	- Density of wet air in fill
L/G	- Liquid to gas or water to air ratio	ρ_{avi}	- Density of wet air at inlet
MBD	- Main beam depth	ρ_{avo}	- Density of wet air at fill exit
ND	- Nozzle depth	ρ_{wm}	- Average wet air density
N_{VH-ai}	- Number of velocity head in air inlet	ρ_{w1}	- Wet air density at inlet
$N_{VH-C/B}$	- Number of velocity heads for fill columns and beams	ρ_{w2}	- Wet air density at exit
N_{VH-DE}	- Number of velocity heads for drift eliminator	x_m	- Absolute air humidity in fill zone
$N_{VH-RZ+SZ}$	- Number of velocity head through the droplet zones (rain + spray)	x_1	- Absolute air humidity at inlet
$N_{VH-Fill}$	- Number of velocity heads for fill	x_2	- Absolute air humidity at exit
N_{VH-T}	- Number of velocity heads for throat	Φ_{ai}	- Air inlet diameter
$N_{VH-Total}$	- Total number of velocity heads for the NDCT	Φ_B	- Base diameter
R	- Range = $(T_1 - T_2)$	Φ_{DE}	- Diameter at the drift eliminator level
RH_1	- Relative humidity at inlet	Φ_e	- Diameter at shell exit
RH_2	- Relative humidity at exit	Φ_F	- Average fill diameter
SBD	- Secondary beam depth	Φ_T	- Throat diameter
SZ	- Spray height/zone	Φ_{vc}	- Vena contracta diameter
TPH	- Available pumping head above ground level		
TYP	- Typical description		
T_1	- Hot water temperature		
T_2	- Cold water temperature		
t_{a1}	- Inlet dry bulb temperature		
t_{a2}	- Exit dry bulb temperature		
t_1	- Inlet wet bulb temperature		

5 NATURAL DRAUGHT COUNTERFLOW COOLING TOWER

A counter flow cooling tower is a device in which the interaction between water and air is at 180° in the fill packing, that is, water falls gravitationally downward and air moves upward.

An NDCT (see [Fig. 1](#)) is a device in which the draught is induced naturally because of the difference in densities between ambient air outside the shell and the air exiting the fill packing inside the shell.

Positions/locations 1 through 7 marked in the following figure identify zones where air properties change during its passage through the NDCT.

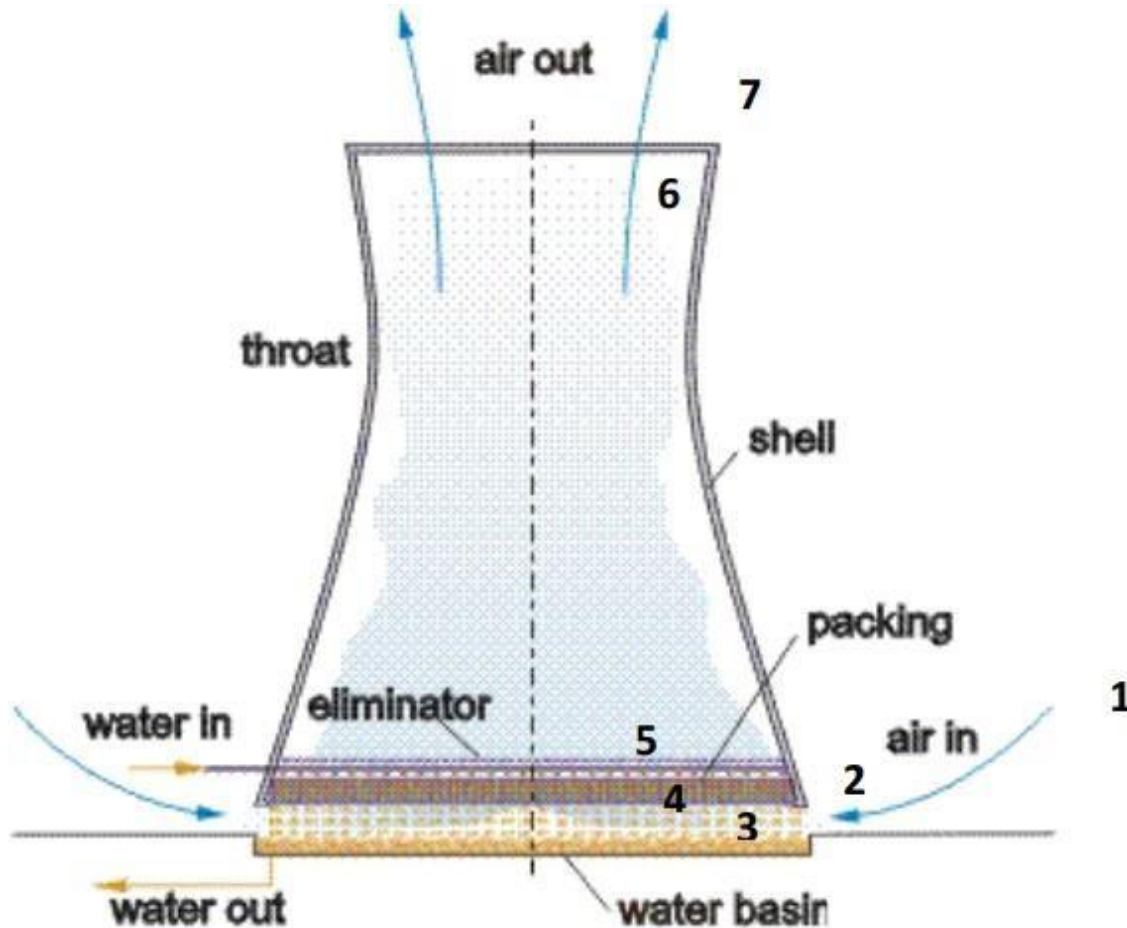

FIG. 1 NATURAL DRAUGHT COUNTERFLOW COOLING TOWER

5.1 Configuration and Components

An NDCT is of hyperboloid shape where its base diameter is larger than its throat/top diameter. The selection of the throat/top diameter involves the determination of the diameter of the vena contracta. Usually, the throat diameter is either the same as the diameter of the vena contracta or slightly less and the top diameter is either equal to or slightly more than the throat diameter depending on environmental considerations (such as; wind speeds at top of shell) and position of the top platform (inside or outside of shell) to prevent cold air (outside air at top of shell level) entry into the shell.

The hyperboloid shape is the result of civil engineering considerations with the sole aim of optimizing material quantities. The angle of the shell at the base is usually between 14° and 21° maximum, with the optimal angle lying somewhere in between.

5.1.1 Air Inlet

5.1.1.1 Air inlet is the open face of the NDCT between the basin kerb level and the shell bottom

through which air is sucked into the tower by the natural draught.

5.1.1.2 Air inlets require sufficient open space all around the NDCT to ensure that unobstructed and uniform air flow into the tower all around is possible with least amount of resistance (see Fig. 2).

5.1.2 Wind Baffle

5.1.2.1 Wind Baffle is a wall provided inside the NDCT to prevent ambient wind blowing at increased speeds (> 3 m/s) from affecting the thermal performance (see Fig. 3). Many wind wall configurations have been tested by researchers and usually (though other types have also been used) it is the solid wind wall that is adopted as shown below. This wind wall configuration has no pressure drop and also saves material quantities.

5.1.2.2 It shall be noted that even though the wind walls reduce the impact of increased wind speeds on thermal performance up to 5 m/s, the wind walls hinder/obstruct air flow at reduced wind speeds (< 3 m/s) and slightly affect thermal performance. Hence, wind walls shall be provided only if the

ambient wind speeds are expected to be greater than 3 m/s for a greater part of the year or when there are no structures like boiler house, office buildings, etc in proximity that in any case act as a baffle to wind flow.

As increased wind speeds affect thermal performance, a cold water temperature correction curve will be required to adjust the performance of the NDCT during a performance guarantee test, if

the test wind speed is above the design wind speed specified in the contract. Designers will have to generate this correction curve for the permissible range of wind speeds based on their NDCT design for a specific type of fill chosen by them and the resulting NDCT sizing. This correction shall be applied to the deviation, if any in the CWT that is determined as per the method described in Appendix-M of CTI Code ATC-105.

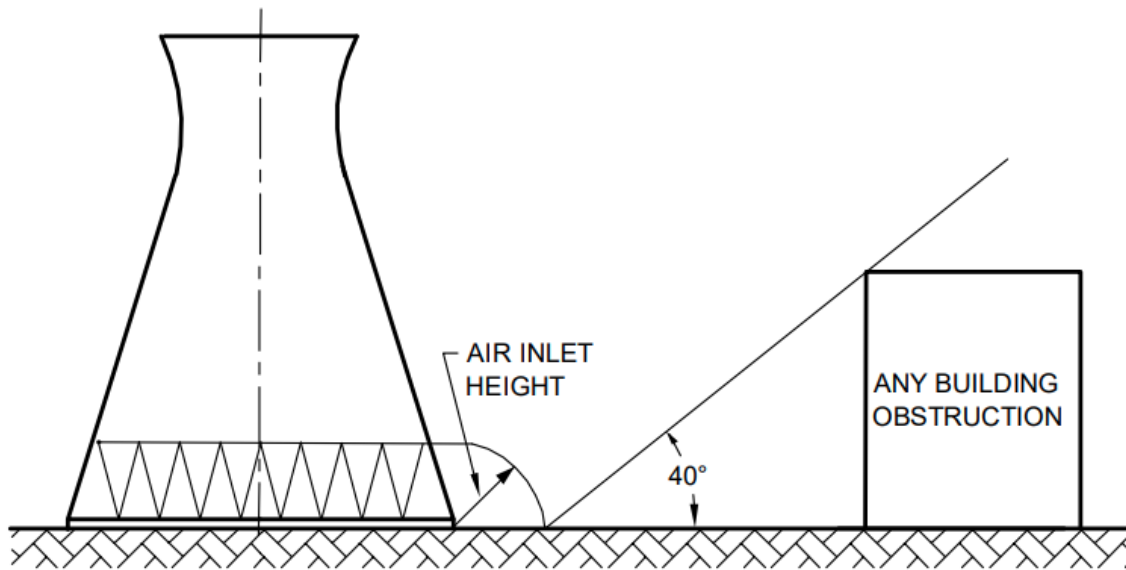

FIG. 2 MINIMUM FREE SPACE REQUIREMENT AROUND NDCT

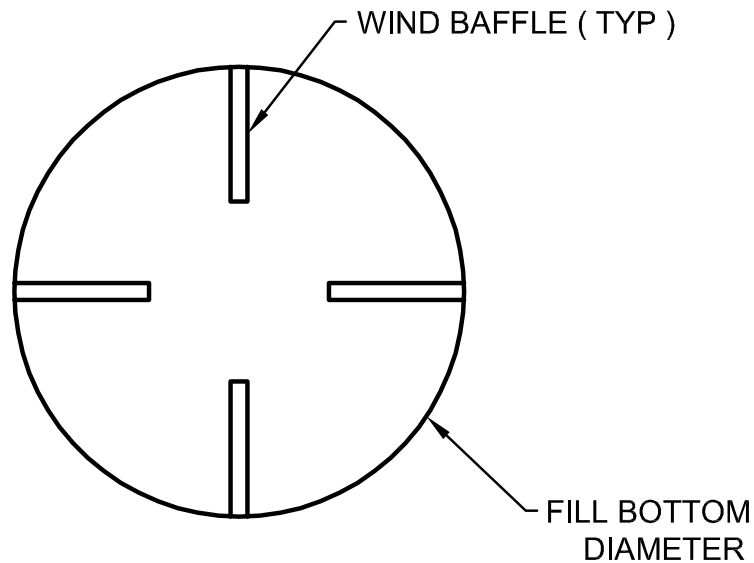

FIG. 3 WIND BAFFLE

5.1.3 Rain Zone

Rain zone is the space between the bottom of fill and the water surface in the basin. Droplets of water falling through the fill are called rain. The rain zone in NDCTs is large and hence, the heat transfer and pressure drop in this zone is required to be considered in the thermal design.

5.1.4 Fill or Heat Transfer Media

The fill or the heat transfer media is the packing inside the NDCT over which hot water is sprayed by nozzles to exchange heat with the upward draught of ambient air. Fills are mainly of three types; film, splash and hybrid.

5.1.4.1 Film fills are a packing which form a film surface over which water slides down either vertically or at an angle depending on the residence time and inter-mixing of water-air desired, also considering non-fouling characteristics required.

Film fills usually have flutes or corrugations on individual sheets that are solvent bonded or buttoned (mechanical assembly) together to form a packing or module (see Fig. 4). The flute sizes vary between 10 mm and 33 mm and are selected based on intended applications like air-conditioning, animal farming, industrial heat transfer and power plant cold end systems.

5.1.4.2 Splash fills come in many shapes and sizes. Some of the popular splash fills for large industrial and power plant applications in India are PP splash grid (see Fig. 5A), PVC Doron V bar (see Fig. 5B), PVC triangular bar (see Fig. 5C), RCC or PVC lath, etc. Wooden laths are still being used in some old process industries.

5.1.4.3 Hybrid fills are a combination of film and splash fills where the mesh structure provides

surfaces for both film and droplet formation. Trickle grids (see Fig. 6) are an example of hybrid fills. These fills are assembled to form modules similar to film fills, thus creating a large heat transfer surface while enhancing anti-fouling characteristics due to the mesh structure.

5.1.5 Distribution System

5.1.5.1 Distribution system in a NDCT comprises of hot water channels/ducts, distribution pipes and spray nozzles. The location and sizing of the distribution system inside the NDCT depends on hydraulic optimization with consideration to flow velocities and duct/pipe sizes.

5.1.5.2 There are three options for choosing the location of the hot water channels/ducts (or more depending on proprietary custom designs) as given in Fig. 7.

5.1.5.3 It is preferable that the riser pipe does not deliver hot water horizontally into the ducts as it affects distribution through the lateral pipes in the immediate proximity. The riser piping can either be routed through the air inlet or below the cold water basin to connect to the hot water ducts from the bottom to discharge water vertically. This helps in uniform distribution of water everywhere in the hot water channel/duct. This is also a civil engineering requirement as large openings in shell are not allowed.

In case the riser piping is preferred to be routed through the air inlet, the area of obstruction to the air flow shall be subtracted from the net air inlet area for pressure drop calculation. Also, the piping in the air inlet shall be adequately protected against corrosion from water droplets in the rain zone.



FIG. 4 AN ASSEMBLED CROSS-CORRUGATED FILM FILL MODULE



FIG. 5A PP SPLASH GRID

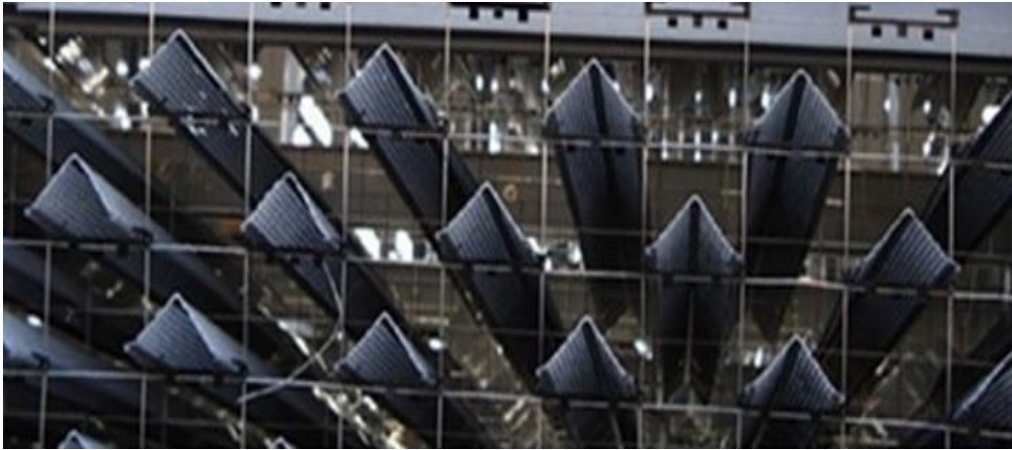

FIG. 5B V BAR

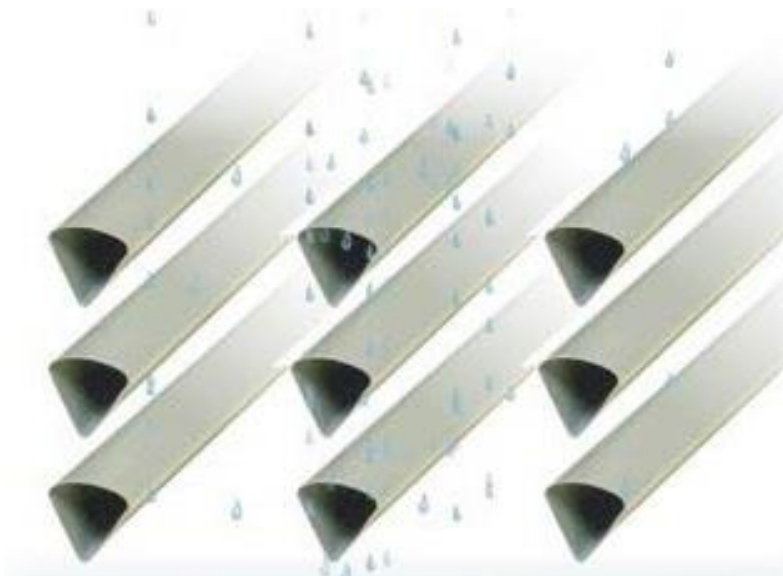

FIG. 5C TRIANGULAR BAR

FIG. 5 SPLASH FILLS

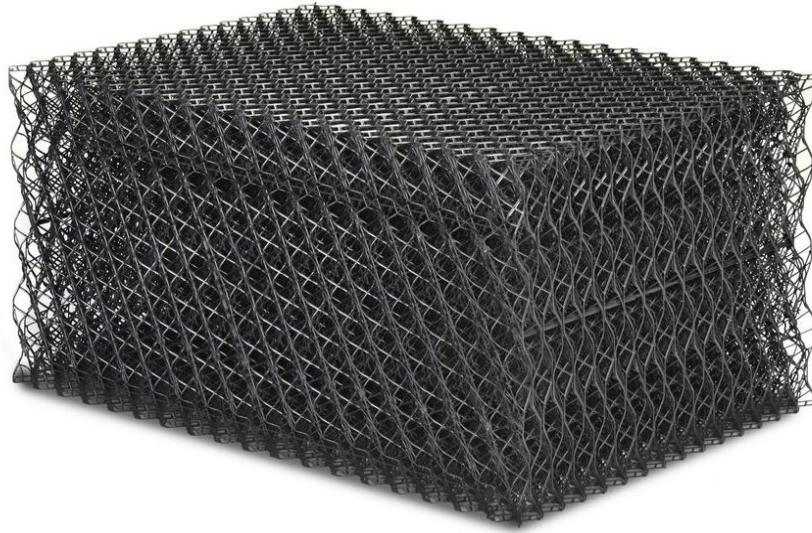

FIG. 6 HYBRID OR TRICKLE GRID FILL

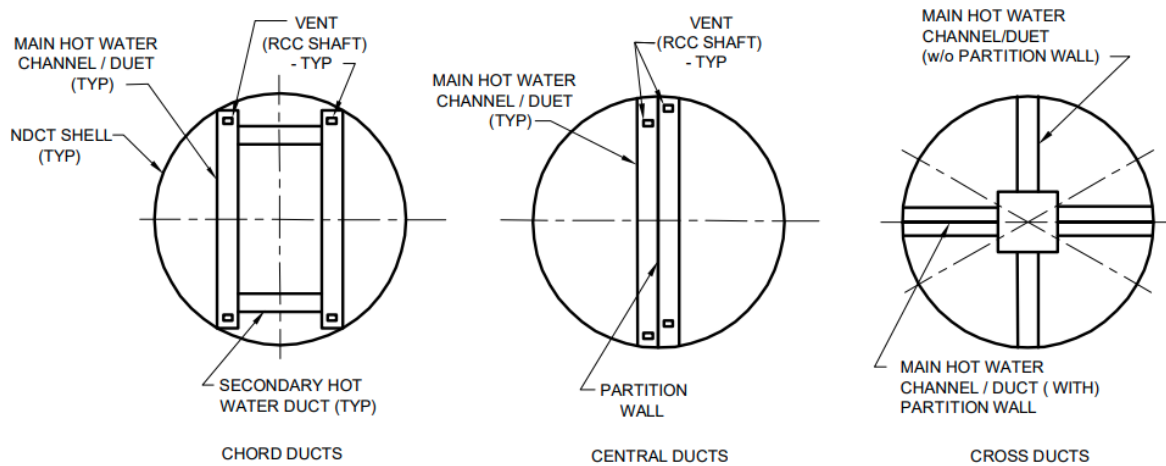

FIG. 7 HOT WATER CHANNELS/DUCTS

5.1.5.4 Distribution pipes are embedded in the hot water channels/ducts to span across the radius of the NDCT. These pipes can be fixed either above or below the supporting beams depending on the nozzle type, size and beam layout (*see Fig. 8*). To fix the pipes below the beams for down spray nozzles, polystyrene saddles, if required and a suitable fastening arrangement may be used. However, the pipes are placed above beams in case of up spray nozzles (*see Fig. 9*), polystyrene saddles, if required and a suitable fastening arrangement may be used.

5.1.5.5 The pressure rating and support span of the PVC pipes for any diameter shall be determined in such a manner as to limit the maximum deflection to within 0.2 percent of support span, that is $L/500$,

where L is the support span. However, for larger PVC pipe diameters (100 NB and above) where foot traffic/point loads may come into play, the bending stress may also be checked to compare with the permissible limit; in this case the live load may be considered as live UDL as such loads will be infrequent.

[Annex B](#) to this guideline gives a solved example of the calculations involved in determining the span of the PVC pipe supports based on the load considerations.

5.1.5.6 Polypropylene spray nozzles are fixed to the distribution pipes at pre-determined locations based

on performance characteristics provided by the manufacturer.

5.1.6 Drift Eliminators

5.1.6.1 Drift eliminators are used in cooling towers to eliminate drift, that is, water particles/droplets being carried away by the up-draught of air. This helps in preventing loss of water and chemicals used for water treatment and also corrosion and nuisance in the NDCT vicinity.

5.1.6.2 Drift eliminator packing is installed above the distribution level in case of pipes fixed below the RCC beams and in between the pipes in case these pipes are placed above the RCC beams.

5.1.6.3 Drift eliminators can be of blade or cellular type (*see Fig. 10*). The choice of the type of drift eliminator will depend on drift loss limitation, associated pressure drop and client specifications.



(ARRANGEMENT SHOWN IS INDICATIVE AND MAY VARY IN PRACTICE)

FIG. 8 DISTRIBUTION PIPES PLACED ABOVE BEAMS

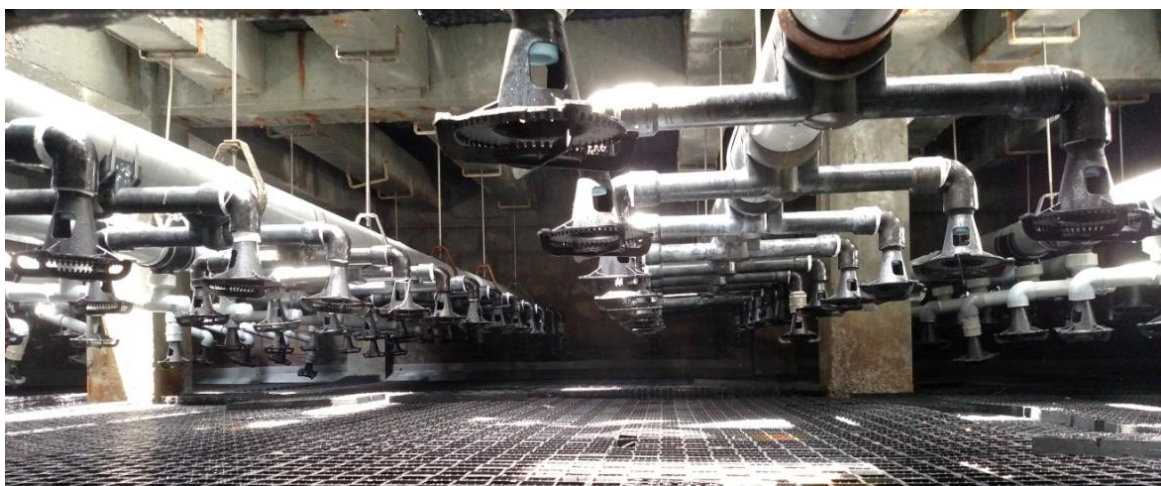

(ARRANGEMENT SHOWN IS INDICATIVE AND MAY VARY IN PRACTICE)

FIG. 9 DISTRIBUTION PIPES FIXED BELOW RCC BEAMS



BLADE TYPE



CELLULAR TYPE

FIG. 10 DRIFT ELIMINATOR PACKING

5.1.7 Vena Contracta

5.1.7.1 Vena Contracta is the narrowing of the air flow after it exits the fill and the point at which this phenomenon occurs above the fill will depend on entering (air inlet) and ambient air velocities.

5.1.7.2 This occurs mainly because the air retains some horizontal momentum from its entry into the NDCT even after it exits the fill. As the magnitude of this horizontal momentum depends on the ratio of the air inlet diameter (bottom of shell) to the air inlet height, the diameter of the vena contracta is estimated using the following formula:

$$\Phi_{vc} = (0.000\ 2 \times (\Phi_{ai}/H)^2 - 0.018\ 3 \times (\Phi_{ai}/H) + 0.860\ 1) \times \Phi_{ai}$$

5.1.8 Throat diameter

5.1.8.1 Throat diameter is the narrowest portion of the hyperboloid which is expected to be located at

the highest point possible where the bottom hyperbola and the upper hyperbola meet. This highest location of the throat is required from thermal performance considerations.

5.1.8.2 The diameter of the throat should be slightly less than or equal to the diameter of the vena contracta, that is, $\Phi_T \leq \Phi_{vc}$ to prevent cold air entry/penetration.

5.1.9 Shell Exit Diameter

5.1.9.1 Shell exit diameter is an important consideration that determines from what height and distance away from the cooling tower the suction into the air inlet begins and also prevents cold air inflow into the NDCT at its upper edge (see [Fig. 11](#)).

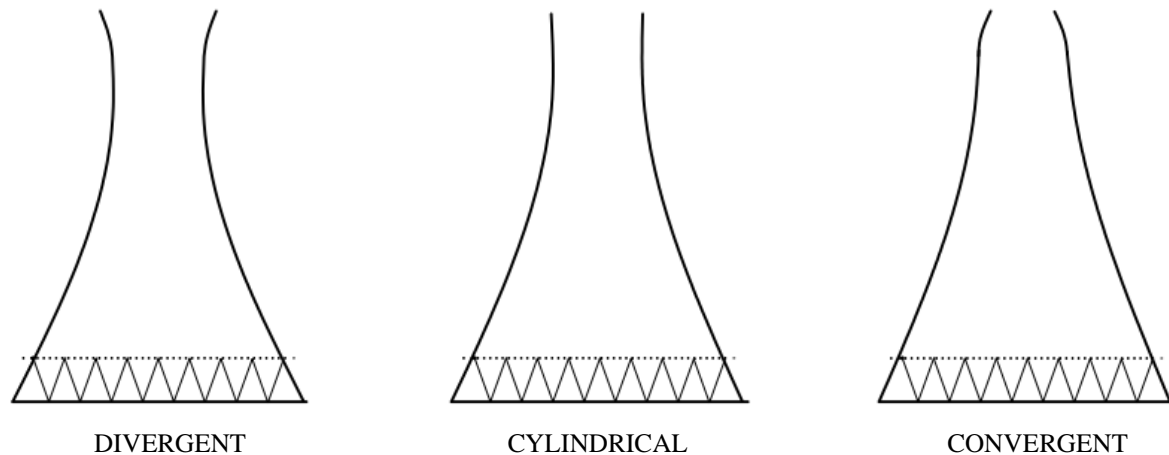

FIG. 11 DIFFERENT SHAPES OF NDCT SHELL EXIT

5.1.9.2 Froude number of a NDCT is shape dependent and indicates how well the cooling tower can perform as a system without getting affected by environmental factors within the permissible variation limits. This is an important factor that determines the exit diameter of the NDCT. The formula for the calculation of froude number is as under:

$$F_{rd} = 2 \times (\Phi_{ai}/\Phi_e)^5 [(\Phi_{ai}/\Phi_e - 0.2 \times H_d/\Phi_{ai})^{-4} - 1]^{-1}$$

This is an iterative calculation for the exit diameter using different values of air inlet diameters at a chosen H_{Tower}/Φ_B or H_d/Φ_{ai} ratio resulting in shape specific froude number values. The $1/F_{rd}$ value should not exceed 3 to prevent cold air entry into the NDCT at its upper edge.

NOTE – It has been found by researches that the cylindrical shape of the upper edge offers the best solution against cold air entry.

5.1.10 Top Platform

A platform needs to be provided at the top of the NDCT for inspection and maintenance activities. The location of this platform can be either inside or outside of the NDCT depending on the shape of the upper hyperbola desired by thermal engineers as explained above.

5.1.11 Butterfly Valve

5.1.11.1 Butterfly valves are used in the cooling tower mainly in the riser piping for open/close operation. Usually, these valves are not used in the header piping for NDCTs.

5.1.11.2 The butterfly valves in riser piping should normally be located 1 200 mm or less above local ground level for ease of operation. Higher

elevations may be used if operating platforms are provided.

5.1.12 Staircase and Top Platform Access

5.1.12.1 A single staircase is sufficient for access to the hot water duct level. A single cage ladder starting from the top landing of the staircase is sufficient for access to the top platform of the NDCT.

5.1.12.2 The aviation obstruction lights shall meet the recommendations in FAA guidelines specific to NDCTs and all other requirements of Director General of Civil Aviation, India, if any.

5.1.12.3 Since most of the NDCTs are around 180 m in height, a single cage ladder would suffice. Multiple cage ladders may be required only when a second level of AOLs is required for NDCT heights exceeding 183 m or 600 ft as recommended in FAA guidelines.

5.1.13 Cold Water Channel (CWC)

Cold water channel (CWC) is an outlet from where re-cooled water flows out of the basin toward the fore bay of a pump house. The CWC will have stop log gates and debris collecting screens.

5.1.13.1 Care shall be taken in sizing the CWC that is dependent on the effective free flow area of the screen size to be installed. The free flow area (or open area) of various screen sizes shall be taken from Table 1 given in IS 2405 (Part 1). This free flow area shall be further reduced by 25 percent to 30 percent or higher depending on the number and size of support members (ISMC) used for the screen frame.

5.1.13.2 If the screen free flow area is 'X percent' and the obstruction from screen frame members is

‘Y percent’, the effective free flow area in percentage will be $X \times (100 - Y)/100$.

5.1.13.3 It will be a good engineering practice to have the CWC width same as the required screen widths (with required wall thicknesses in between for mounting the frames) calculated as above considering the flow velocity specified across the screen (usually 0.7 m/s to 1 m/s).

5.2 Heat Transfer Process

5.2.1 Heat transfer process in a cooling tower involves mainly the evaporation of a small quantity of water from a large circulating flow to cool it from a given hot water temperature to a specific cold water temperature (see Fig. 12). The difference between the hot and cold water temperatures is called the ‘range’.

5.2.2 Since the evaporation of water occurs due to its contact with a draught of air, the cooling process is limited by the WBT of ambient air and the driving force for this cooling process is the enthalpy

difference between the air film in contact with water surface and the bulk air moving through the tower.

5.2.3 Many texts and references are available to study the derivation of heat and mass transfer equation of the cooling tower, which is as below:

$$KaV/L = \int_{t_2}^{t_1} dT/(h_w - h_a)$$

5.2.4 Chebychev method given in CTI Blue Book and BS 4485 shall be used to solve for demand KaV/L using the duty parameters specified.

5.2.5 The value of KaV/L or the NTU is an indication of the difficulty of the cooling duty drawn in the form of demand curves. Whereas the L/G ratio of fill is taken from the intersection of the specific demand curve with the fill characteristic curve generated for a specific fill type, height and spacing or flute size (see Fig. 13).

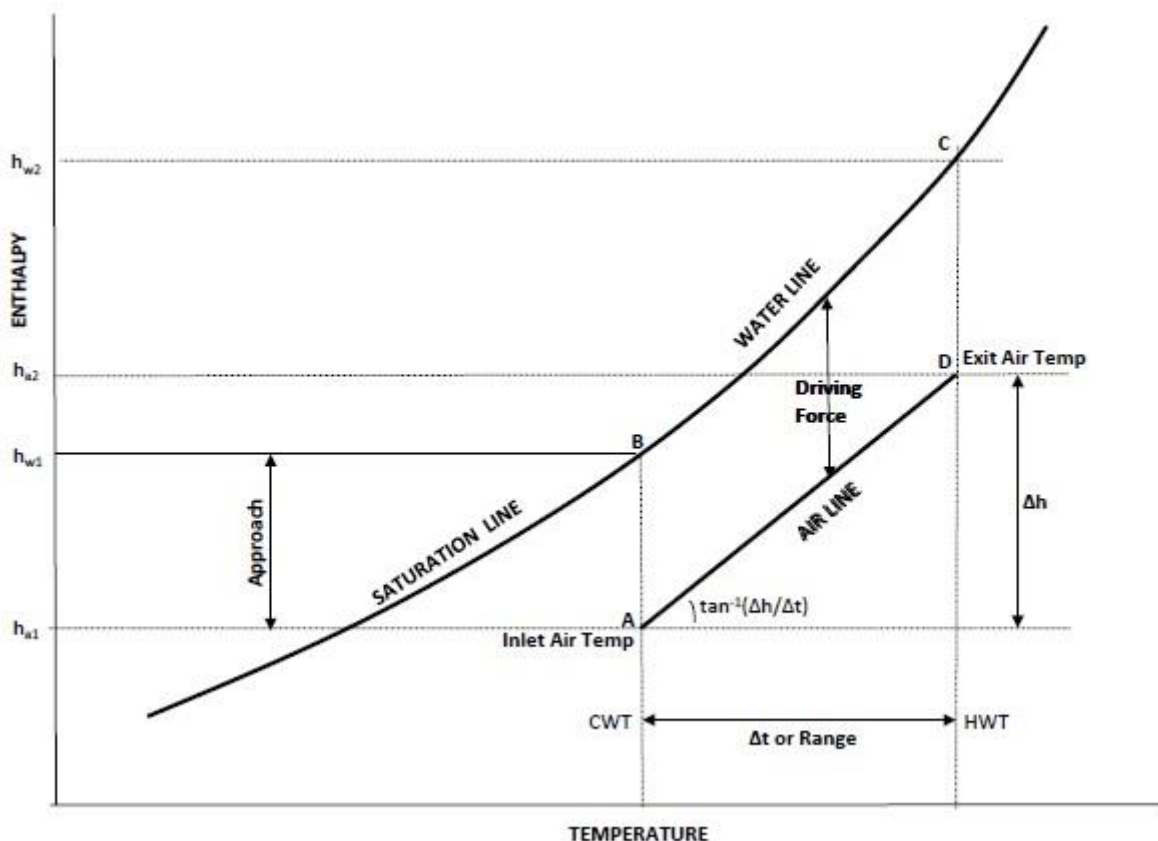

FIG. 12 HEAT TRANSFER DIAGRAM

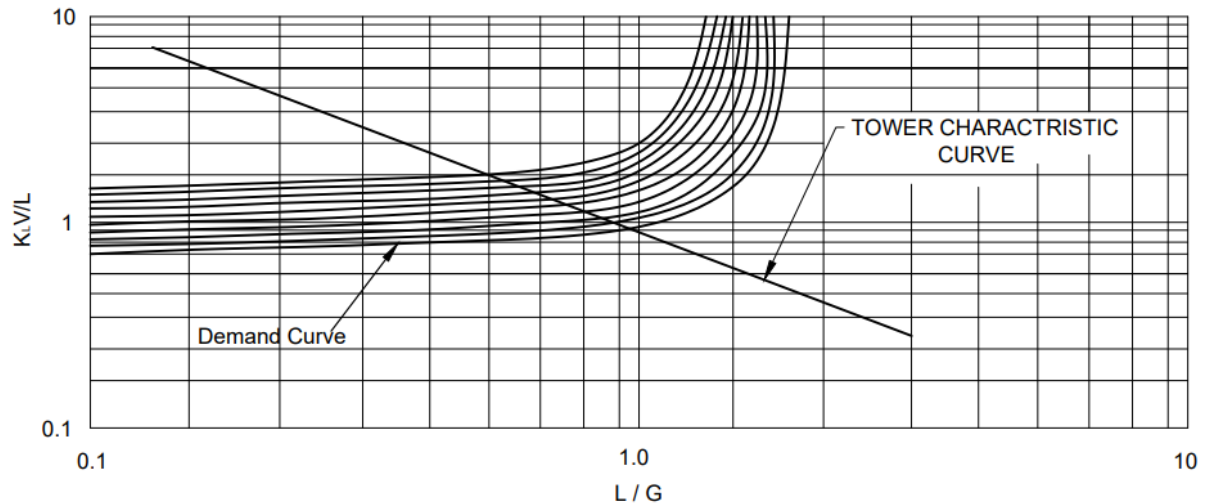

FIG. 13 TOWER DEMAND AND CHARACTERISTIC CURVE

5.2.6 However, unlike IDCTs that rain zone in NDCTs is quite large and effects a significant KaV/L gain and pressure drop that needs to be considered in thermal design. Hence, the KaV/L gain in the rain zone shall be added to the KaV/L generated by the fill.

Hence,

$$(KaV/L)_{\text{Tower}} = (KaV/L)_{\text{rain}} + (KaV/L)_{\text{Fill}}$$

The design L/G for the tower will be at a point where the combined KaV/L from fill and rain zone meet the demand KaV/L . Once the design L/G is established for the design of the NDCT, the heat balance is achieved using the equation:

$$(L \times C_p \times R) + (E_v \times C_p \times t_2) = G(h_2 - h_1)$$

5.2.7 For a given tower design the tower characteristic in terms of KaV/L demand and design L/G is given as under:

$$\begin{aligned} KaV/L &= C \times (L/G)^{-n} \text{ or } KaV/L \\ &= C \times L^{-n} \times G^m \times HWT^{-k} \times FH \end{aligned}$$

Depending on the accuracy of results required.

5.3 Specifying Thermal Design Duty

5.3.1 Specifying Wet-Bulb Temperature and Relative Humidity

Specifying the thermal design duty involves providing the parameters required for the design of the cooling tower. The duty parameters to be specified are as under:

- a) Circulating water flow rate (m^3/h);

- b) Hot water temperature ($^{\circ}\text{C}$);
- c) Cold water temperature ($^{\circ}\text{C}$);
- d) Ambient WBT ($^{\circ}\text{C}$);
- e) Relative humidity (in percentage);
- f) Site altitude (above msl);
- g) Salinity of circulating water (in case of sea water);
- h) Elevation of basin kerb above ground level; and
- j) Available pumping head above ground level or normal water level.

5.3.1.2 Care shall be taken in specifying the pumping head as splash fills require a higher pump head than film fills because of the higher fill heights involved. Adequate pumping head must be made available for splash fill towers depending on fill heights envisaged to ensure that ϕ_{ai}/H ratio and the F_{rd} no. detailed in subsequent sections are satisfied.

5.3.1.3 Specifying the design ambient WBT and relative humidity (RH) requires a statistical analysis of the hourly meteorological data for at least a five consecutive year period for the project site (taken from the nearest India meteorological department or from the project site, if it is an expansion project). The analysis should include WBT and coincidental DBT or RH for the same hour for the period under consideration.

5.3.1.4 The design ambient WBT and coincidental DBT or RH shall be selected in such a way that it is not exceeded by more than 5 percent of the period under consideration in a year (usually April to September).

5.3.2 Effect of Altitude on Thermal Design

5.3.2.1 The effect of altitude on thermal design shall be considered only when the site elevation above MSL exceeds 300 m (see Fig. 14).

5.3.2.2 The available driving force increases slightly with increasing altitudes (significant only beyond 300 m) resulting in smaller dimensions of NDCT.

5.3.3 Effect of Salinity on Thermal Design

5.3.3.1 Salinity reduces the vapour pressure and specific heat capacity and increases the density of sea water compared to pure or fresh water (see Fig. 15).

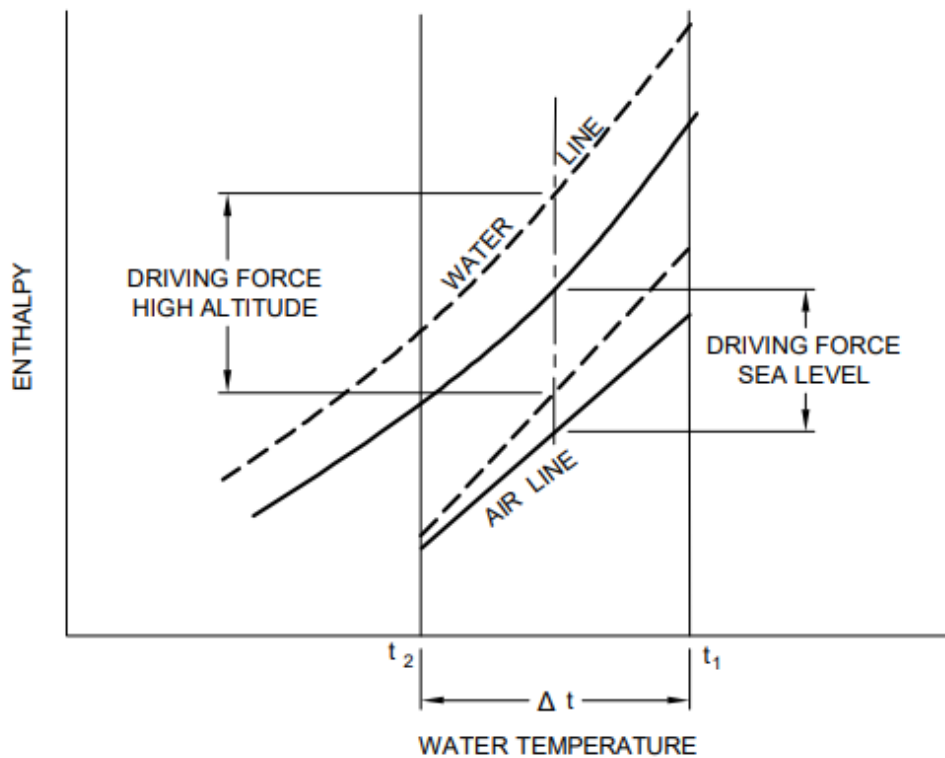

FIG. 14 EFFECT OF ALTITUDE ON DRIVING FORCE

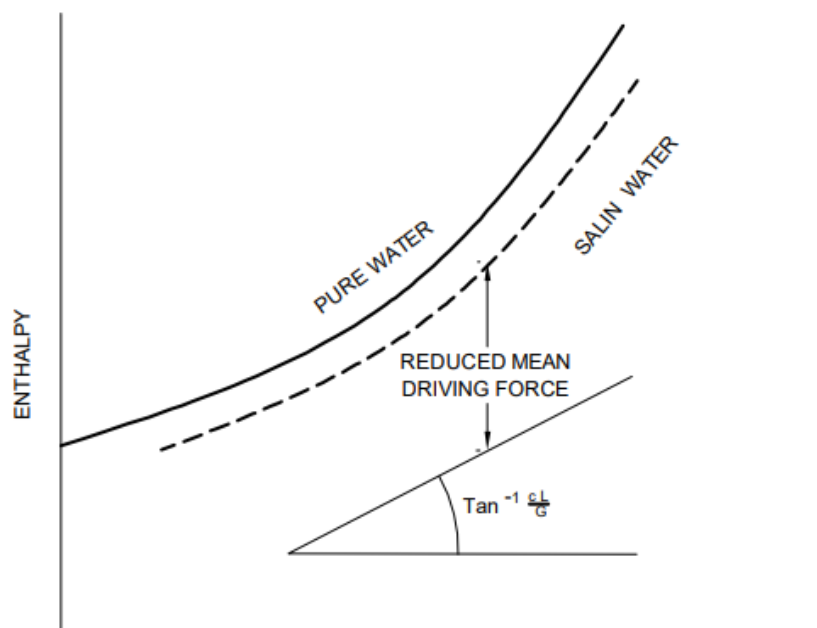

FIG. 15 EFFECT OF SALINITY ON DRIVING FORCE

5.3.3.2 On the water side, in effect the increase in density of sea water is offset by the reduction in its specific heat capacity. Hence, these effects shall be ignored in thermal design. However, since the heat transfer is effected through the saturated vapour, which has a reduced pressure due to salinity, the resulting enthalpy is also reduced thereby, reducing the available driving force, which shall be accounted for in thermal design.

5.3.4 Specifying a Fill for Thermal Design

5.3.4.1 Specifying a fill for thermal design involves consideration of the circulating water quality. Film fills are sensitive to water quality whereas splash fills work well with slightly poor water quality provided, there is no biological growth and excessive suspended matter.

5.3.4.2 Specific water quality requirements may be obtained from fill manufacturers based on their field performance data. In most of the cases the major source of fouling is biological growth and suspended matter. Oxidising biocides are the most effective bio-control agents and hence, shall be used depending on water quality analysis and recommendations from the fill manufacturer and/or a specialist water treatment agency.

5.3.4.3 It shall be noted that fill selection is a compromise between thermal efficiency and fouling characteristics and hence, shall be considered carefully in consultation with fill manufacturers and cooling tower designers.

5.4 Thermal Design Method

5.4.1 The thermal design of a NDCT involves the following steps:

- Establishing design KaV/L and L/G values from fill and rain zones;
- Establishing pressure drops through various zones inside the NDCT; and
- Using the draught equation to establish the draught height of the NDCT.

5.4.1.1 The establishing of the design L/G involves a few iterations as the demand KaV/L from the specified thermal duty (range, approach and WBT) is met by the individual NTUs generated by the fill and the rain zone. These iterations can easily be performed in an excel sheet.

5.4.1.2 Once the design L/G is established the pressure drops through various sections inside the NDCT can be calculated.

5.4.1.3 Once the pressure drops are calculated, the draught height of the NDCT can be established using

the following equation(s):

5.4.1.4 Detailed draught equation

$$\begin{aligned} (P_1 - P_7) - (P_1 - P_{34}) - (P_{34} - P_6) - (P_6 - P_7) \\ = (N_{VH-ai} + N_{VH-C/B}) \times \rho_{avi} \\ \times v_{ai}^2/2 + N_{VH-RZ} \times \rho_{avi} \times v_{ai}^2/2 \\ + N_{VH-Fill} \times \rho_{avf} \times v_{Fill}^2/2 + (N_{VH-DS} + N_{VH-DE} \\ + N_{VH-T}) \times \rho_{avo} \times v_{ao}^2/2 \end{aligned}$$

P_1 is the ambient air pressure at ground level, P_3 through P_6 are the air pressures at various locations inside the NDCT (see Fig. 1) and P_7 is the ambient air pressure outside the NDCT near the top edge. The units on both sides will be N/m^2 .

5.4.1.5 Simplified Draught Equation

$$H_d = \Delta p / \Delta \rho$$

The equation for Δp used above applies when the number of velocity heads are referred to the fill diameter in the calculations.

5.4.1.6 The detailed draught equation requires a large program to determine the Φ_B and H_d values, whereas the simplified draught equation requires fewer steps to arrive at the NDCT sizing. As this guideline is prepared with a view to simplify the NDCT design process so that it is understood by one and all, the simplified draught equation will be adopted here for further explanation of design steps involved.

5.4.1.7 The details and calculation methods provided in this guideline generally apply to the design of uniform air-water distribution in NDCTs.

5.4.1.8 When a hot water distribution system is designed in such a way to deliver a constant flow through each of the nozzles, it is assumed that the air and water loading is uniform over the entire fill area. However, in actual practice the air flow through the fill will vary across its diameter because of the resistance offered by the rain zone below fill and because of this phenomenon the L/G varies across the diameter and as a consequence the exit air temperature too. The average L/G and exit air temperature considered in design is a result of the assumption that these variations are minimal and do not affect the results of the highly accurate mathematical formulations resulting in simplified calculations.

5.4.2 NTU from Fill

NTU from fill is estimated using the performance characteristics from the manufacturer's published data. However, such performance characteristic data for some of the established fills that are

commonly used in the industry is given below.

- a) 19 mm cross fluted film fill (C.10.19 of Munters)

$$KaV/L = 1.864 \times (L/G)^{-0.8621} \times (3.28 \times FH)^{0.8764} \times (196.8 \times v_{Fill})^{-0.1902}$$

- b) 27 mm cross fluted film fill (C.10.27 of Munters)

$$KaV/L = 0.57 \times (L/G)^{-0.7227} \times (3.28 \times FH)^{0.6706} \times (196.8 \times v_{Fill})^{-0.02745}$$

- c) MC 75 cross fluted packing (19 mm of Marley)

$$KaV/L = 1.035 \times (L/G)^{-0.781} \times (3.28 \times FH)^{0.584}$$

- d) Splash grid — 200 mm spacing (Cooldeck Opti Grid)

$$KaV/L = 0.71 \times (L/G)^{-0.42} \times FH^{0.5}$$

These guidelines do not cover all the types of fills, hence users are required to evaluate and verify the authenticity of the fill data received either through manufacturer's in-house laboratory or third party laboratories as performance guarantees are involved.

5.4.3 NTU from the Rain Zone

NTU from the rain zone can be estimated using the following equation, if no other data is available:

$$(KaV/L)_{rain} = 0.016072 \times \text{rain height} \times (L/G)^{-0.5}$$

where

rain height = air inlet height (H).

5.4.4 NTU from Nozzle Spray

Even though a small KaV/L gain occurs in the spray zone when the tower is new, it is soon lost within the first 2 to 3 years as fouling of the system begins. As the tower is no longer new after commissioning, this small gain should be ignored for the sake of conservatism that is much needed in the design of cooling towers. However, if the project specific tender specifications have no restrictions on this aspect and permits this gain in the spray zone, designers may consider the same in their thermal designs provided they have nozzle specific performance data in terms of droplet size distribution and the associated KaV/L contribution established in a test rig.

5.4.5 Pressure Drops

Pressure drop estimation requires feedback from field erected cooling towers to assess accuracy of theoretical data. The pressure drops calculations are presented in [Annex A](#).

5.5 Design Optimization

Design optimization involves several checks requiring multiple thermal design runs before arriving at the best solution to achieve guaranteed performance.

Designs should be run with different fill heights and spacing for the chosen/specified fill type to arrive at the most economical solution. Each of the design runs will result in a different Φ_B for a given H_{Total}/Φ_B ratio. It shall be ensured that Φ_{ai}/H ratio does not exceed 14 ($\Phi_{ai}/H \leq 14$) for each of the design runs to ensure that excessive pressure drops through air inlet do not occur and distort the air distribution through the tower and affect thermal performance. Generally, the smaller this ratio the better the performance.

The Φ_{ai}/H ratio also affects the $1/F_{rd}$ value, which should always be less than 3 for the NDCT to perform as expected.

5.5.1 Water Wall-Bypass

Water wall-bypass can be as high as 1 percent to 5 percent in large field erected cooling towers. A water wall-bypass of about 3 percent (for properly erected fill with good workmanship) shall be considered for all splash fill designs as this phenomenon occurs invariably at all junctions with RCC members and cell walls. This consideration can be in terms of increase in design circulating water flow by 3 percent. Some bypass is bound to occur in film fill towers too, but to a much lesser extent and can be limited to about 2 percent of circulating water flow.

5.5.2 Cooling towers with fill packing extending downward into the air inlet should not be opted for as the performance of the portion of the fill in the air inlet gets halved and affects overall thermal performance. Such configurations with just one or two layers of splash fill extending into the air inlet should be considered only when the available pumping head is an insurmountable issue and adequate de-rating of fill performance is considered.

NDCTs with fill packing completely above the air inlet are found to be performing as per design in field experiments.

5.5.3 The pumping head required for a splash fill tower is between 2 mWC and 4 mWC more than that with a film fill. This is a large increase in pumping energy resulting not only in increased operating costs but also increased carbon emissions. Hybrid fills may be considered in such cases as the height required for these fills will be comparable with that of film fills.

5.5.4 In most of the cases involving fresh or slightly brackish water applications, it may be possible to use film fills even with a necessity to replace fills once in 7 to 8 years because of fouling/scaling as the replacement costs will still be economical compared to the increase in energy costs with splash fill. A basic water treatment program will be required for both film and splash fill applications because the first zone that gets affected in any cooling tower because of poor water quality is the distribution system and the condenser tubing too gets fouled at the same time with poor quality water circulation.

5.5.5 Splash fills have either been completely eliminated or on the fast decline in many parts of the world due to the following reasons:

- a) Requires higher pump head;
- b) Takes longer to install;
- c) Prevents easy access to fill level for maintenance of nozzles;
- d) Certain types of splash fills with slotted surfaces cannot be cleaned once choked; and
- e) Splash fills can sag with the passage of time affecting thermal performance.

5.5.6 The performance of all types of fills gets affected because of a poorly designed or performing distribution system, more so for a splash fill packing. Hence, the choice of fill shall be made by the designer and/or cooling tower owner weighing all the options as suggested.

5.5.7 Once the individual N_{VH} values (from air inlet through throat, where throat diameter is the same as exit diameter) are calculated as explained above, the total number of velocity heads for the NDCT is arrived at by summation,

$$N_{VH-Total} = N_{VH-ai} + N_{VH-RZ+SZ} + N_{VH-Fill} + N_{VH-C/B} + N_{VH-DE} + N_{VH-T}$$

where

$$\Delta p = N_{VH-Total} \times \rho_{avf} \times v_F^2 / 2g; \text{ and}$$

$$\Delta \rho = \rho_{avi} - \rho_{avo}.$$

Hence, the required draught height of the NDCT will be $H_d = \Delta p / \Delta \rho$ and the required total height of the NDCT will be $H_{Total} = H_d + FH/2 + \text{beam depth} + H$.

The above calculations can be repeated with different fill types, fill heights and spacing, air inlet heights and H_{Total}/Φ_B ratios for a techno-economic analysis of designs.

5.5.8 Chilton has defined Merkel number in 'the performance of natural draught water-cooling towers', which is $\alpha = 1/(KaV/L) + L/2G$. This number is characteristic of the tower and can be used to calculate the tower performance coefficient as under:

$$C = \alpha G/L \times (N_{VH-Total})^{1/3}$$

It is seen that C is an indication of the efficiency of the fill used in design and hence, this value remains nearly constant independent of the NDCT size and varying (off-design) duty conditions.

5.5.9 The value of C is generally found to be between 3 and 4 for film fills (depending on their heat transfer surface and thermal efficiency) and between 4 and 5.5 for splash fills (sometimes higher for poorly performing splash fills). Values outside this range will result in uneconomical tower designs.

5.5.10 It is also possible to design a NDCT to achieve a specific value of C (within the range) depending on the type of fill chosen. Once the value of C is determined it is possible to arrive at a combination of NDCT dimensions in terms of Φ_B and H_{Total} using a parameter called duty coefficient (D_C). This coefficient is generally not used in thermic designs these days.

The duty coefficient is related to the performance coefficient in terms of the pond area at sill and height of the NDCT as under:

$$D_C = \frac{A \sqrt{H_{Total}}}{C \sqrt{C}}$$

Many combinations of Φ_B and H_{Total} are possible for different H_{Total}/Φ_B ratios for a given fill configuration and pumping head limits.

5.6 Hydraulic Design

Hydraulic design involves sizing of the hot water header piping, riser piping, hot water channel/duct and distribution piping and the associated pressure drops.

5.6.1 Hot Water Piping

The header and the riser piping shall be sized for a velocity of 2 m/s and 2.5 m/s or less as per industry practice to optimize costs. The number of TEEs, Bends and reducers shall be as few as possible to reduce pressure drops in the circuit.

5.6.2 Hot Water Channel

Since the distribution system is of gravity type in cooling towers, the hot water channel/duct is open to atmosphere. This channel shall be sized for a velocity not between 1 m/s and 1.6 m/s (≤ 1.6 m/s).

5.6.3 Distribution Pipe Sizing

5.6.3.1 The distribution pipes embedded in the hot water channel shall be sized for velocities not greater than 1 m/s to 1.15 m/s. As the length of these pipes can be very long (> 30 m) in NDCTs, reducers to change to smaller pipe diameters after a certain distance, based on residual flow volume can be adopted.

5.6.3.2 The water head above the distribution piping should generally not exceed 1.15 m in case of gravity flow type. However, in a pressurized hot water distribution system, the spray nozzle head requirement will normally be 1.2 mWC to 1.5 mWC.

5.6.4 Spray Nozzle Selection

Down spray nozzles that work efficiently with water head between 0.5 m to 0.85 m must be opted for in case of gravity type distribution system. In the case of a pressurized distribution system, the nozzle head requirement may range between 1.2 mWC and 1.5 mWC.

All nozzle selections shall be made using the manufacturer's nozzle curves that present performance in terms of water head, spray zone height and nozzle discharge diameters.

5.7 Tower Performance

5.7.1 Tower performance is critical in all plants, especially in power plants where revenues and carbon emissions are directly related to the heat rate that the plant can achieve. However, the cooling tower in a power plant is part of the 'cold end system' that includes the condenser too.

5.7.2 As power plant engineers perform design optimization studies on the cold end system considering sizing and performance of both cooling tower and condenser, it automatically follows that

the operation and maintenance of cooling tower or the condenser cannot be looked at in isolation. This is because any performance related issues with the cooling tower will affect the performance of the condenser and vice versa.

5.7.3 Any choking/fouling/scaling of fill or distribution system in the cooling tower is an indication of a similar occurrence in the condenser tubing as well. Both systems shall be cleaned at the same time to ensure that performance of one end does not deteriorate because of neglect of the other.

5.7.4 Similarly, power plant engineers shall be conscious about all such operational parameters that affect condenser pressure, which in turn affects cooling tower performance. For example, high energy drains to the condenser (from boiler, turbine cycle drains, etc), recirculation lines, attemperation lines, heater bypass lines, heater drains, etc, shall not be left open as these badly affect the condenser pressure and also result in large heat losses. This is especially critical during the PG testing of cooling towers as the performance will be under reported even if the towers are performing well.

5.7.5 Most often the cooling tower contractors are blamed for performance related issues of the cold end system. However, it should be the responsibility of the power plant operator also to investigate contributing causes in the power plant as above. In addition, the operator should also investigate the condenser itself for the following:

- a) Vacuum pump performance;
- b) Air ingress into the condenser (parting plane bolting, strainer bolting, all flange connections bolting, glands, etc);
- c) Condenser tube fouling/scaling; and
- d) CW water flow rate.

Without investigating and correcting the above parameters, insisting on cooling tower performance ignoring the dependent parameters/conditions will not help the cause of the industry. Adequate care shall be taken by plant operators to ensure that all the above and other dependent parameters are taken care of to achieve desired performance of the cooling towers.

5.7.6 Once the above aspects are adequately addressed by the plant operators and the cooling tower runs at close to design parameters, a performance guarantee test can be undertaken to establish the tower capability and deviation from guaranteed design cold water temperature, if any.

ANNEX A

(Clause 5.4.5, Annex B and Annex C)

PRESSURE DROP CALCULATIONS

A-1 This has already been done by various cooling tower designers and many reports and technical bulletins are available for reference. It is advised that the recommendations in the subsequent sections be followed as a minimum to arrive at a reasonably accurate thermal design of NDCTs. However, the designer should feel free to improve on the recommended pressure drops based on their own research information.

NOTE — The pressure drop calculations presented in this guideline are based on methods suggested by R. F. Rish in his technical paper ‘Design of a natural draught cooling tower’.

A-1.1 As per this method the number of velocity heads (N_{VH}) is calculated first at each of the zones in the NDCT and these individual velocity heads are added to get ($N_{VH-Total}$) the total number of velocity heads for the tower. This $N_{VH-Total}$ is then used to calculate the pressure drop through the NDCT using the mid-fill packing conditions of air density (ρ_{avf}) and velocity (v_f).

A-2 Number of velocity heads through the air inlet can be calculated using the formula given below:

$$N_{VH-ai} = 0.167 \times (\Phi_{ai}/H)^2$$

A-3 As per R. F. Rish, the rain zone and spray zone are treated together to arrive at the combined velocity heads due to all sizes of droplets. The number of velocity heads through the droplet zones (rain + spray) can be calculated using the formula:

$$\begin{aligned} N_{VH-RS+SZ} &= 0.16 \times \{(RZ + SZ) \times 3.28\} \\ &\quad \times (L/G)^{1.32} \\ &= 0.5248 \times (H + SZ) \times (L/G)^{1.32} \end{aligned}$$

as the rain zone height (RZ) is the same as air inlet height (H).

A-4 The data on number of velocity heads is not readily available for modern day fills. Manufacturers have developed complex but reliable performance equations through laboratory testing for all types of fills in the industry. These performance equations directly result in the pressure drop values. Hence, the number of velocity heads for fill required as per R. F. Rish method can be derived from the pressure drop thus estimated as below:

$$[N_{VH-Fill} = \Delta p \times 2g / (\rho_{avf} \times v_{fill}^2)]$$

A-5 The fill performance data presented in this guideline is taken from data provided by manufacturers and that available in public domain. All the data presented is for face velocities between 300 FPM and 700 FPM. However, the manufacturers have advised that the fill performance for face velocities below 300 FPM can be determined using the same fill equations with accuracy as the performance is enhanced with reducing face velocities. Hence, the pressure drop equations for some of the popular fills used in the industry that were tested for face velocities up to 700 FPM are as under:

a) 19 mm cross fluted film fill:

$$\begin{aligned} \Delta p &= (C_0 + C_1 \times WL \times 1.47234 + \\ &C_2 \times v_{fill} \times 196.8 + C_3 \times v_{fill} \times 196.8 \times \\ &WL \times 1.47234 + C_4 \times (1.47234 \times \\ &WL)^2 + C_5 \times (196.8 \times v_{fill})^2 + C_6 \times \\ &196.8 \times v_{fill} \times (1.47234 \times WL)^2 + \\ &C_7 \times (196.8 \times v_{fill})^2 \times 1.47234 \times \\ &WL) \times (FH \times 3.28)^{0.75} \times (\rho_{avf} / \\ &1.12) \times 25.4 \text{ (mmWC)} \end{aligned}$$

where

$$\begin{aligned} C_0 &= -0.00023; \\ C_1 &= 0.0019157; \\ C_2 &= 4.1771 \times 10^{-5}; \\ C_3 &= -1.1197 \times 10^{-5}; \\ C_4 &= -4.3422 \times 10^{-5}; \\ C_5 &= 1.8258 \times 10^{-7}; \\ C_6 &= 4.5739 \times 10^{-7}; \text{ and} \\ C_7 &= 1.93 \times 10^{-8}. \end{aligned}$$

NOTE — Data has been taken from Munters.

b) 27 mm cross fluted film fill:

$$\begin{aligned} \Delta p &= (1.47234 \times WL \times (C_{x0} \times 196.8 \times \\ &v_{fill} - C_{x1}) + C_{x2} \times (196.8 \times v_{fill})^2) \times \\ &(FH \times 3.28)^{0.7} \times (\rho_{avf} / 1.12) \times 25.4 \\ &\text{ (mmWC)} \end{aligned}$$

where

$$\begin{aligned} C_{x0} &= 9.5135 \times 10^{-6}; \\ C_{x1} &= 0.0007583; \text{ and} \\ C_{x2} &= 1.648 \times 10^{-7}. \end{aligned}$$

NOTE — Data has been taken from Munters.

- c) MC 75 cross fluted packing:

$$\Delta p = (4.34 \times 10^{-8} \times (196.8 \times v_{\text{fill}})^{2.3559} + 1.47234 \times WL \times 8.11 \times 10^{-07} \times 196.8 \times (v_{\text{fill}})^{1.5403}) \times (1 + 2.83 \times 10^{-01} \times 3.28 \times FH) \times \rho_{\text{avf}}/1.2 \times 25.4. \text{ (mmWC)}$$

NOTE — Data has been taken from Marley.

- d) Splash grid — 200 mm spacing (Cooldeck Opti grid):

$$\Delta p = 2.88 \times WL^{0.85} \times (WL/(L/G))^{-0.6} \times FH^{1.17} \times \rho_{\text{avf}}/1.22 \times (v_{\text{fill}})^2/2g \text{ (mmWC)}$$

NOTE — This equation for splash grid/PP grid is taken from Dr. Kruger's book. All equations presented above include end effects.

A-6 Users are advised to consult the respective manufacturers of the above types of fills and get the equations reaffirmed before using them in their calculations and/or computer programmes. Requirements defined in [A-9](#) below may also be considered by designers before using the above equations in their thermal designs.

A-7 It has become a practice now a days for end users to specify that the fill being proposed to be used by the contractor in their project be tested in a

third-party test facility to evaluate its thermal performance and that the data acquired from the test rig be used for thermal design. Hence, the fill performance data presented in this guideline must be carefully chosen by users based on manufacturer feedback, their own experience and research and specific tender conditions that require performance guarantees.

A-8 The number of velocity heads due to columns and beams inside the NDCT is suggested to be 2.3 by R. F. Rish. Hence, this number should be considered as a minimum.

A-9 The number of velocity heads through the distribution system and drift eliminator is calculated using the formula:

$$N_{\text{VH-DE}} = 4.76 \times (\Phi_{\text{F}}/\Phi_{\text{DE}})^4$$

A-10 The number of velocity heads through the Throat of the NDCT is calculated using the formula:

$$N_{\text{VH-T}} = 1.01 \times (\Phi_{\text{F}}/\Phi_{\text{T}})^4$$

In case the shell exit diameter is larger than the throat diameter, the expansion loss because of the increase in diameter shall be considered in the total pressure drop and the draught height required shall be calculated accordingly and the Froud no. must also be checked for compliance.

ANNEX B

*(Foreword and clause 5.1.5.5)***SOLVED EXAMPLE OF A NDCT THERMIC DESIGN FOR FRESH WATER APPLICATION**

SI No.	Solved Example of a NDCT Thermic Design for Fresh Water Application						
i)	Design duty parameters						
	Water flow rate, L	= 73 100 m ³ /h					
		= 321 852 gpm					
	Hot water temp, T_1	= 40.6 °C					
	Cold water temp, T_2	= 31.6 °C					
	Wet bulb temperature, t_1	= 26 °C					
	Relative humidity, RH_1	= 47 percent					
	Elevation above mean sea level, $EMSL$	= 0 m					
	Available pumping head above ground level, TPH	= 14.2 m (say)					
NOTE — Change in air properties may be considered in design only when $EMSL$ is 300 m or more (Ref. BS 4485/BSEN14705).							
ii)	<p>The water flow rate is not increased in this solved example by the wall-bypass factor of 3 percent that is recommended in the guideline because most often end users refuse to specify certain design criteria and leave it to the discretion of the contractor, in which case all that is not specified in the tender but required as per design practice will get ignored in a competitive bidding environment. Hence, an appropriate decision in this regard shall be taken based on end user specifications.</p>						
	<p>The above thermal duty demands a specific KaV/L value that can be made available by the fill and the rain zone where heat transfer takes place. KaV/L gain in the spray zone is ignored in this example but a decision in this regard may be taken by the users as per recommendations in the guideline.</p>						
	<p>The $(KaV/L)_D$ demand can be calculated using the Chebychev/Tchebycheff method outlined in ATC-105 or BS 4485, etc.</p>						
	<p>The solution to the problem lies in finding out what combination of fill and rain zone heights provides the KaV/L demanded by the thermal duty. However, the problem can only be solved when the exit air temperature is known so that the design liquid to gas ratio L/G can be determined. Obviously, this warrants iterative calculations to arrive at the correct exit air temperature and the consequent L/G. However, it may be noted that there are several possible methods of solving this thermal problem. One such method is explained below:</p>						

SI No.	Solved Example of a NDCT Thermic Design for Fresh Water Application						
iii)	Fill Selection for KaV/L calculation						
	Assume Marley ill MC75 film fill suitable for fresh water application						
	Fill height, FH	= 1.8 m (say)					
	The performance equations of this fill presented at 5.4.2 of the guidelines are as under:						
	$(KaV/L)_{fill}$	= $1.035 \times (L/G)^{-0.781} \times (3.28 \times FH)^{0.584}$					
	Therefore, $(KaV/L)_{fill}$	= $1.035 \times (L/G)^{-0.781} \times (3.28 \times 1.8)^{0.584}$					
		= $2.92 \times (L/G)^{-0.781}$					
	The performance equations of rain zone presented at 5.4.3 of the Guidelines are as under:						
	$(KaV/L)_{rain}$	= $0.0049 \times \text{rain height} \times (L/G)^{-0.5}$					
	Here, rain height = air inlet height = H_1 (ft)						
	The air inlet is derived from the available pumping head as under:						
	Ground level to basin sill	= 0.3 m					
	Main beam dept, MBD	= 0.5 m (say)					
	Secondary beam depth, SBD	= 0.25 m (say)					
	Fill depth, FH	= 1.8 m					
	Spray height/zone, SZ	= 0.6 m (say)					
	Nozzle depth, ND	= 0.2 m (say)					
	Head required for nozzle	= 0.85 m (say)					
	Head loss in HW piping + distribution system	= 1 m (say)					
	Sub-total, HL	= 5.5 m					
	Possible air inlet height, $H_1 = TPH - HL$	= 8.7 m					
	Therefore, $(KaV/L)_{rain}$	= $0.016072 \times 8.7 \times (L/G)^{-0.5}$					
		= $0.14 \times (L/G)^{-0.5}$					
KaV/L available from fill + rain zones, $(KaV/L)_A$	= $(KaV/L)_{fill} + (KaV/L)_{rain}$						
	= $2.92 \times (L/G)^{-0.781} + 0.14 \times (L/G)^{-0.5}$						

SI No.	Solved Example of a NDCT Thermic Design for Fresh Water Application										
	This $(KaV/L)_A$ will have to be matched with $(KaV/L)_D$ to determine the exit air temperature and the design L/G										
iv)	The heat balance equation of a cooling tower is $(L \times C_p \times \text{range}) + (E_v \times C_p \times T_2) = G \times \Delta h$, where										
	$E_v = \text{evaporation loss (kg/h)}$										
	E_v loss can be calculated once inlet and outlet air properties are established										
	Specific heat, C_p	= 1 (kcal/kg/°C)									
	$\Delta h = \text{inlet enthalpy - outlet enthalpy}$	= $(h_1 - h_2)$ kcal/kg									
	Range = $(T_1 - T_2)$	= 9 °C									
	$G = \text{dry air flow rate (kg/h)}$										
	Solving this equation without knowing what the L/G and exit air temperature would be is a little cumbersome and requires an iterative process. The CTI ATC-105 heat balance equation ignores the heat of evaporated water for the sake of simplifying the calculations. However, in actual practice where design performance is guaranteed, this heat from the evaporated water cannot be ignored and hence, iterative calculations are required to be carried out. Equations are readily available for the calculation of air properties in BS, ASHRAE, DIN, Kroger, etc publications. As using tables is a laborious process, equations from Kroger's book are used here for demonstration purposes. The CTI tables cannot be used for NDCT design as they do not have air properties at varying relative humidities, It may be noted that the $(KaV/L)_D$ value varies with the tables/equations from different publications because of the datum differences. However, a uniform method of calculation based on any of these specific publications in their entirety will result in more or less comparable NDCT sizing.										
v)	Inlet air properties (from equations):										
	Design inlet WBT, t_1	= 26 °C									
	Relative humidity, RH_1	= 47 percent									
	Dry bulb temperature (DBT), t_{a1}	= 35.51 °C									
	Wet-air density, ρ_{w1}	= 1.131 78 kg/m ³									
	Abs humidity, x_1	= 0.017 32 kg/kg									
	Enthalpy, h_1	= 19.171 kcal/kg									
vi)	For a conservative design, it shall be assumed that the exit air is fully saturated, that is its RH is 100 percent										
	Now, assume an exit air temperature of say, $[(T_1 + T_2)/2] = (40.6 + 31.6)/2 = 36.1$ °C for the first iteration										

SI No.	Solved Example of a NDCT Thermic Design for Fresh Water Application					
	Exit air properties (from equations):					
	WBT, t_2 at 100 percent RH	= 36.1 °C				
	Relative humidity, RH_2	= 100 percent				
	Dry bulb temperature (DBT), t_{a2}	= 36.1 °C				
	Abs humidity, x_2	= 0.039 18 kg/kg				
	Enthalpy, h_2	= 32.741 kcal/kg				
	Now rearrange the heat balance equation for L/G as under:					
	$L/G = (\Delta h - (x_2 - x_1) \times C_p \times T_2)/(C_p \times \text{Range})$					
	Substituting values, we get L/G	= 1.431				
	Now, as the L/G and exit air enthalpy are both known, the $(KaV/L)_D$ can be calculated using the Tchebycheff method					
	(Refer ATC-105 or BS 4485 codes for a detailed description of the Tchebycheff method)					
	As per the Tchebycheff method all enthalpies are considered at 100 percent RH					
Iteration No.1	Water Temperature Distribution (between T_1 and T_2)	Enthalpy at Water Temperature (h_w)	Enthalpy Distribution (h_a)	$(h_w - h_a)$	$1/(h_w - h_a)$	
	31.6		19.171			
	32.5	27.235 5	20.458 9	6.776 6	0.147 57	
	35.2	31.276 3	24.322 6	6.953 8	0.143 81	
	37	34.268 2	26.898 4	7.369 8	0.135 69	
	39.7	39.266 0	30.762 1	8.503 9	0.117 59	
	40.6		32.050 0			
				$\Sigma 1/(h_w - h_a)$	0.544 66	
	As per Tchebycheff method $(KaV/L)_D = \text{Range}/4 \times \Sigma 1/(h_w - h_a) \times C_p$					
	Therefore, $(KaV/L)_D = 1.225$					
	Now, let's check how well $(KaV/L)_A$ meets the $(KaV/L)_D$ calculated					
	We have $(KaV/L)_A = 2.92 \times (L/G)^{-0.781} + 0.14 \times (L/G)^{-0.5}$					
	Substituting L/G value, we have $(KaV/L)_A = 2.324 2$					

SI No.	Solved Example of a NDCT Thermic Design for Fresh Water Application						
Iteration No. 2	As the $(KaV/L)_D$ and $(KaV/L)_A$ do not match, the Exit Air Temperature will have to be iterated until these two values match closely						
	Exit air properties (from equations):						
	Wet bulb temperature (WBT), t_2 at 100 percent RH	= 38.88 °C					
	Relative humidity, RH_2	= 100 percent					
	Dry bulb temperature (DBT), t_{a2}	= 38.88 °C					
	Wet-air density, ρ_{w2}	= 1.101 7 kg/m ³					
	Abs humidity, x_2	= 0.046 03 kg/kg					
	Enthalpy, h_2	= 37.680 kcal/kg					
	Substituting values, we get L/G	= 1.956					
	Water Temperature Distribution (between T_1 and T_2)	Enthalpy at Water Temperature (h_w)	Enthalpy Distribution (h_a)	$(h_w - h_a)$	$1/(h_w - h_a)$		
	31.6		19.171				
	32.5	27.235 5	20.931 1	6.304 4	0.158 62		
	35.2	31.276 3	26.211 5	5.064 9	0.197 44		
	37	34.268 2	29.731 7	4.536 5	0.220 43		
	39.7	39.266 0	35.012 1	4.253 8	0.235 08		
	40.6		36.772 2				
				$\Sigma 1/(h_w - h_a)$	0.811 57		
	As per Tchebycheff method $(KaV/L)_D = \text{range}/4 \times \Sigma 1/(h_w - h_a) \times C_p$						
	Therefore, $(KaV/L)_D = 1.826$						
	Now, let's check how well $(KaV/L)_A$ meets the $(KaV/L)_D$ calculated						
	We have $(KaV/L)_A = 2.92 \times (L/G)^{-0.781} + 0.14 \times (L/G)^{-0.5}$						
	Substituting L/G value, we have $(KaV/L)_A$	= 1.829					

SI No.	Solved Example of a NDCT Thermic Design for Fresh Water Application					
	The iterations will end here as $(KaV/L)_A$ closely meets the $(KaV/L)_D$ calculated at the assumed exit air temperature and the air properties established in this iteration will be used for further calculations.					
vii)	Dry air flow through the NDCT, G_a	$= L/(L/G)$				
	Therefore, G_a	$= 37\,377\,996.53$ kg/h				
	Average wet air density, $\rho_{wm} = (\rho_{w1} + \rho_{w2})/2$	$= 1.116\,7$				
	Absolute humidity in fill zone, $x_m = (x_1 + x_2)/2$	$= 0.031\,67$				
	Average wet air flow through fill, $G_{wm} = G_a \times (1 + x_m)/\rho_{wm}$	$= 34\,531\,117.58$ m ³ /h				
		$= 9\,591.98$ m ³ /s				
	Wet Air Flow through Inlet, G_{w1}	$= G_a \times (1 + x_1)/\rho_{w1}$				
	Therefore, G_{w1}	$= 33\,597\,558.57$ m ³ /h				
		$= 9\,332.655$ m ³ /s				
	Density difference, $\Delta\rho$	$= \rho_1 - \rho_2$				
	or $\Delta\rho$	$= 0.030$ kg/m ³				
	At this stage the diameter of the NDCT will be required to estimate the pressure drops and use the draught equation and as the dimensions of the NDCT are not known, we need to make an initial assumption of the base/sill diameter and the H/Φ ratio. The H/Φ ratio specified in India based on structural design considerations is between 1.2 and 1.5. The choice of H/Φ ratio is dependent on many considerations like design wind speed for structural design, construction costs, cost of fill, client preferences, etc, let us assume an average H/Φ or H_d/Φ_f (draught height/fill diameter) ratio of 1.35 for this solved example.					
		Iteration 1			Iteration 2	
	Assume an initial value of base/sill diameter of the NDCT, Φ_B	$= 100$ m			$= 120.78$ m	
	Now, it follows that the diameter at the top of air inlet, Φ_{ai}	$= \Phi_B - 2 \times H_1 \times \tan(\theta)$				
	θ = shell angle at the base, say 16.7°					
	Therefore, Φ_{ai}	$= 94.78$ m			$= 115.56$ m	
	The ratio, Φ_{ai}/H_1	$= 10.89$			$= 13.28$	
	The diameter of fill at midpoint or average fill diameter, Φ_f	$= \Phi_B - 2 \times (H_1 + FH/2 + SBD + MBD) \times \tan(\theta)$				
		$= 93.79$ m			$= 114.57$ m	

SI No.	Solved Example of a NDCT Thermic Design for Fresh Water Application					
	Area at this level of fill, A_{fill}	= 6 908.76 m ²			= 10 309.31 m ²	
	Effective area of fill considering 10 percent obstructions to air flow, A_3	= 6 217.89 m ²			= 9 278.38 m ²	
		= 66 894.50 ft ²			= 99 820.48 ft ²	
	The afflux velocity through fill, v_{fill}	= G_{wm}/A_3				
		= 1.54 m/s			= 1.03 m/s	
		= 303.59 FPM			= 203.45 FPM	
	Effective Water Loading over the fill area, WL	= L/A_3				
		= 4.81 gpm/ft ²			= 3.22 gpm/ft ²	
	Diameter at the drift eliminator level, Φ_{DE}	= $\Phi_f - 2 \times (FH/2 + SZ + ND + SBD) \times \tan(\theta)$				
		= 92.62 m			= 113.40 m	
	Diameter of vena contracta, Φ_{vc}	= $(0.000 2 \times (\Phi_{ai}/H_1)^2 - 0.018 3 \times (\Phi_{ai}/H_1) + 0.860 1) \times \Phi_{ai}$				
	Therefore, Φ_{vc}	= 64.874 m			= 75.381 m	
	Diameter at the throat level, Φ_T	= 62.874 m (say)			= 73.381 m (say)	
	The total pressure drop through the NDCT is required to be calculated to solve the draught equation. Hence, the individual velocity heads N_{VH} in each of the zones will have to be calculated using equations given at Annex A of the guideline.					
	N_{VH-ai}	= $0.167 \times (\Phi_{ai}/H)^2$				
		= 19.820			= 29.464	
	$N_{VH-RZ+SZ}$	= $0.524 8 \times (H_1 + SZ) \times (L/G)^{1.32}$				
		= 11.830			= 11.830	
	MC75 fill pressure drop as per Annex A of the guideline, Δp	= $(4.34 \times 10^{-08} \times v_{fill}^{2.355 9} + 8.11 \times 10^{-07} \times v_{fill}^{1.540 3} \times WL) \times (1 + 2.83 \times 10^{-01} \times FH) \times \rho_{wm}/1.2$				
	(Corrected for density)	= 0.079 inchWC			= 0.053 inchWC	
		= 2.018 mmWC			= 1.346 mmWC	
	Therefore, $N_{VH-Fill}$	= $\Delta p \times 2g/(\rho_{wm} \times v_{fill}^2)$				
		= 14.902			= 22.120	
	$N_{VH-C/B}$	= 2.3			= 2.3	

SI No.	Solved Example of a NDCT Thermic Design for Fresh Water Application						
	N_{VH-DE}	$= 4.76 \times (\Phi_f/\Phi_{DE})^4$					
		$= 4.881$			$= 4.859$		
	$N_{VH-Throat}$	$= 1.01 \times (\Phi_f/\Phi_T)^4$					
		$= 5.001$			$= 6.002$		
	Therefore, total resistance through the NDCT, $N_{VH-Total}$	$= 58.734$			$= 76.574$		
	The total pressure drop through the NDCT, Δp	$= \rho_{wm} \times N_{VH-Total} \times v_{fill}^2/2g$					
		$= 7.956 \text{ mmWC}$			$= 4.658 \text{ mmWC}$		
	Using the draught equation $H_d \times \Delta\rho = \Delta p$, we get $H_d \times \Delta\rho$	$= 1.35 \times \Phi_f \times \Delta\rho$					
		$= 3.812 \text{ kg/m}^2$			$= 4.657 \text{ kg/m}^2$		
	The base/sill diameter of the NDCT shall be iterated upon until the LHS and RHS values match closely (as in iteration 2)						
	H_d	$= 154.71 \text{ m}$					
	It shall be noted that this manual method of solving the thermic problem was possible only because the fill selected did not have velocity as a variable in its KaV/L equation. For fills with velocity as a variable, an initial assumption of diameter Φ_B is to be made at the KaV/L calculation stage itself and further iterations carried out. With multiple values to guess at the initial stage, a program in excel will be necessary to solve the thermic problem quickly.						
	Total height of NDCT above sill, H_{Total}	$= H_d + FH/2 + SBD + MBD + H_1$					
		$= 165.06 \text{ m}$					
	Basin dia at sill, Φ_B	$= 120.78 \text{ m}$					
viii)	Check for heat balance						
	$(L \times C_p \times \text{range}) + (E_v \times C_p \times T_2) = G_a \times \Delta h$						
	$E_v = (x_2 - x_1) \times G_a$						
	Therefore, E_v	$= 1\,073\,479.706 \text{ kg/h}$					
	The LHS of the equation will be	$= 691\,821\,958.7 \text{ kcal/h}$					
	and The RHS of the equation will be	$= 691\,821\,958.7 \text{ kcal/h}$					
ix)	In situations where the end User/EPC contractor wants to cross check any NDCT contractor's design received as part of a bidding process, the iterations on the base diameter shown at 7 above will not apply because the base diameter and the NDCT height are declared by the NDCT contractor in his bid. In such cases the end User/EPC contractor can directly use the base diameter declared by the NDCT contractor and procedure with pressure drop calculations and draught balance.						

ANNEX C

(Foreword)

SOLVED EXAMPLE OF A NDCT THERMIC DESIGN FOR SEA WATER APPLICATION

SI No.	Solved Example of a NDCT Thermic Design for Sea Water Application					
i)	Design duty parameters					
	Water flow rate, L	= 73 100 m ³ /h				
		= 321 852 gpm				
	Hot water temperature, T_1	= 40.6 °C				
	Cold water temperature, T_2	= 31.6 °C				
	Wet bulb temperature, t_1	= 26 °C				
	Relative humidity, RH_1	= 47 percent				
	Salt content (in make-up water)	= 38 500 ppm				
	Elevation above mean sea level, $EMSL$	= 0 m				
	Available pumping head above ground level, TPH	= 14.2 m (say)				
NOTE — Change in air properties may be considered in design only when $EMSL$ is 300 m or more (Ref BS 4485/BSEN14705).						
ii)	<p>Let's say that this sea water circulating system runs at a COC of 1.5. This means that the salinity to be considered in thermic design will be $(38\ 500 \times 1.5)$ 57 750 ppm. The effect of this salinity in sea water is that it reduces the vapor pressure that in turn reduces the enthalpy, thus reducing the available driving force. As there are no enthalpy tables published in any code for sea water, the only way to design a NDCT for sea water application is by using equations for air properties. As mentioned in the previous example with fresh water, any set of published equations or tables for air properties from any code or standard can be used for thermic design to result in more or less identical NDCT sizing. However, it shall be ensured that the data used and the method applied for calculations shall be uniform throughout to get proper results.</p>					
	<p>The thermic design method presented for sea water application is identical with that of fresh water except that the vapor pressure is corrected for salinity using the equation given at 8.7.3 of BS 4485.</p>					

SI No.	Solved Example of a NDCT Thermic Design for Sea Water Application					
iii)	Fill Selection for KaV/L calculation					
Even though the Marley MC75 Film Fill is not suitable for sea water application, let's use this fill in this solved example for sea water application to demonstrate how the NDCT sizing varies with the change in vapor pressure due to salinity and the consequent reduction in enthalpies. If not for this example, a splash fill should have been chosen for sea water application.						
Fill height, FH		= 1.8 m (say)				
The performance equations of this fill presented at 5.4.2 of the guidelines are as under:						
$(KaV/L)_{fill}$		= $1.035 \times (L/G)^{-0.781} \times (3.28 \times FH)^{0.584}$				
Here, FH is in feet						
Therefore, $(KaV/L)_{fill}$		= $1.035 \times (L/G)^{-0.781} \times (3.28 \times 1.8)^{0.584}$				
		= $2.92 \times (L/G)^{-0.781}$				
The performance equations of rain zone presented at 5.4.3 of the guidelines are as under:						
$(KaV/L)_{rain}$		= $0.016\ 072 \times \text{Rain height} \times (L/G)^{-0.5}$				
The air inlet is derived from the available pumping head as under:						
Ground level to basin sill		= 0.3 m				
Main beam dept, MBD		= 0.5 m (say)				
Secondary beam depth, SBD		= 0.25 m (say)				
Fill depth, FH		= 1.8 m or 6 ft				
Spray height/zone, SZ		= 0.6 m (say)				
Nozzle depth, ND		= 0.2 m (say)				
Head required for nozzle		= 0.85 m (say)				
Head loss in HW piping + distribution system		= 1 m (say)				
Sub-total, HL		= 5.5 m				
Possible air inlet height, $H_1 = TPH - HL$		= 8.7 m				
		= 28.536 ft				
Therefore, $(KaV/L)_{rain}$		= $0.016\ 072 \times 8.7 \times (L/G)^{-0.5}$				
		= $0.14 \times (L/G)^{-0.5}$				

SI No.	Solved Example of a NDCT Thermic Design for Sea Water Application						
	KaV/L available from fill + rain zones , $(KaV/L)_A$	$= (KaV/L)_{fill} + (KaV/L)_{rain}$					
		$= 2.92 \times (L/G)^{-0.781} + 0.14 \times (L/G)^{-0.5}$					
	This $(KaV/L)_A$ will have to be matched with $(KaV/L)_D$ to determine the exit air temperature and the design L/G						
iv)	The heat balance equation of a cooling tower is $(L \times C_p \times range) + (E_v \times C_p \times T_2) = G \times \Delta h$						
	where						
	E_v = evaporation loss (kg/h)						
	E_v loss can be calculated once inlet and outlet air properties are established						
	Specific Heat, C_p						
	Δh = inlet enthalpy - outlet enthalpy						
	Range = $(T_1 - T_2)$						
	G = dry air flow rate (kg/h)						
Solving this equation without knowing what the L/G and exit air temperature would be is a little cumbersome and requires an iterative process. The CTI ATC-105 heat balance equation ignores the heat of evaporated water for the sake of simplifying the calculations. However, in actual practice where design performance is guaranteed, this heat from the evaporated water cannot be ignored and hence, iterative calculations are required to be carried out. Equations are readily available for the calculation of air properties in BS, ASHRAE, DIN, Kroger, etc publications. As using tables is a laborious process, equations from Kroger's book are used here for demonstration purposes. The CTI tables cannot be used for NDCT design as they do not have air properties at varying relative humidities, It may be noted that the $(KaV/L)_D$ value varies with the tables/equations from different publications because of the datum differences. However, a uniform method of calculation based on any of these specific publications in their entirety will result in more or less comparable NDCT sizing.							
v)	Inlet air properties (from equations):						
	Design inlet WBT, t_1						
	Relative humidity, RH_1						
	Dry bulb temperature (DBT), t_{a1}						
	Wet-air density, ρ_{w1}						
	Abs humidity, x_1						
	Enthalpy, h_1						

SI No.	Solved Example of a NDCT Thermic Design for Sea Water Application				
vi)	For a conservative design, it shall be assumed that the exit air is fully saturated, that is its <i>RH</i> is 100 percent				
	Now, assume an exit air temperature of say, $((T_1+T_2)/2) = (40.6+31.6)/2 = 36.1$ °C for the first iteration				
	Exit air properties (from equations):				
	WBT, t_2 at 100 percent <i>RH</i>	= 36.1 °C			
	Relative humidity, RH_2	= 100 percent			
	Dry bulb temperature (DBT), t_{a2}	= 36.1 °C			
	Abs humidity, x_2	= 0.039 18 kg/kg			
	Enthalpy, h_2	= 32.741 kcal/kg			
	Now rearrange the heat balance equation for <i>L/G</i> as under:				
	$L/G = (\Delta h - (x_2 - x_1) \times C_p \times T_2)/(C_p \times \text{range})$				
	Substituting values, we get <i>L/G</i>	= 1.431			
	Now, as the <i>L/G</i> and exit air enthalpy are both known, the $(KaV/L)_D$ can be calculated using the Tchebycheff method				
	(Refer ATC-105 or BS 4485 codes for a detailed description of the Tchebycheff method)				
	As per the Tchebycheff method all enthalpies are considered at 100 percent <i>RH</i>				
Iteration No. 1	Water Temperature Distribution (between T_1 and T_2)	Enthalpy at Water Temperature (h_w)	Enthalpy Distribution (h_a)	$(h_w - h_a)$	$1/(h_w - h_a)$
	31.6		19.171		
	32.5	26.857 8	20.458 9	6.399 0	0.156 28
	35.2	30.829 1	24.322 6	6.506 5	0.153 69
	37	33.767 8	26.898 4	6.869 4	0.145 57
	39.7	38.673 7	30.762 1	7.911 6	0.126 40
	40.6		32.050 0		
				$\Sigma 1/(h_w - h_a)$	0.581 94
	As per Tchebycheff method $(KaV/L)_D = \text{Range}/4 \times \Sigma 1/(h_w - h_a) \times C_p$				

SI No.	Solved Example of a NDCT Thermic Design for Sea Water Application				
	Therefore, $(KaV/L)_D = 1.309$				
	Now, let's check how well $(KaV/L)_A$ meets the $(KaV/L)_D$ calculated				
	We have $(KaV/L)_A = 2.92 \times (L/G)^{-0.781} + 0.14 \times (L/G)^{-0.5}$				
	Substituting L/G value, we have $(KaV/L)_A = 2.324 2$				
Iteration No. 2	As the $(KaV/L)_D$ and $(KaV/L)_A$ do not match, the exit air temperature will have to be iterated until these two values match closely				
	Exit air properties:				
	Wet bulb temperature (WBT), t_2 at 100 percent RH = 38.53 °C				
	Relative humidity, RH_2 = 100 percent				
	Dry bulb temperature (DBT), t_{a2} = 38.53 °C				
	Wet-air density, ρ_{w2} = 1.103 5 kg/m ³				
	Abs humidity, x_2 = 0.045 11 kg/kg				
	Enthalpy, h_2 = 37.021 kcal/kg				
	Substituting values, we get $L/G = 1.886$				
	Water Temperature Distribution (between T_1 and T_2)	Enthalpy at Water Temperature (h_w)	Enthalpy Distribution (h_a)	$(h_w - h_a)$	$1/(h_w - h_a)$
	31.6		19.171		
	32.5	26.857 8	20.868 2	5.989 7	0.166 95
	35.2	30.829 1	25.959 7	4.869 4	0.205 36
	37	33.767 8	29.354 1	4.413 7	0.226 57
	39.7	38.673 7	34.445 6	4.228 1	0.236 51
	40.6		36.142 8		
				$\Sigma 1/(h_w - h_a)$	0.835 40
	As per Tchebycheff method $(KaV/L)_D = \text{range}/4 \times \Sigma 1/(h_w - h_a) \times C_p$				

SI No.	Solved Example of a NDCT Thermic Design for Sea Water Application			
	Therefore, $(KaV/L)_D$	$= 1.880$		
	Now, let's check how well $(KaV/L)_A$ meets the $(KaV/L)_D$ calculated			
	We have $(KaV/L)_A = 2.92 \times (L/G)^{-0.781} + 0.14 \times (L/G)^{-0.5}$			
	Substituting L/G value, we have $(KaV/L)_A$	$= 1.881$		
	The iterations will end here as $(KaV/L)_A$ closely meets the $(KaV/L)_D$ calculated at the assumed exit air temperature and the air properties established in this iteration will be used for further calculations.			
vii)	Dry air flow through the NDCT, G_a	$= L/(L/G)$		
	Therefore, G_a	$= 38\ 764\ 214.18\ \text{kg/h}$		
	Average wet air density, $\rho_{wm} = (\rho_{w1} + \rho_{w2})/2$	$= 1.117\ 6$		
	Absolute humidity in fill zone, $x_m = (x_1 + x_2)/2$	$= 0.031\ 21$		
	Average wet air flow through fill $G_{wm} = G_a \times (1+x_m)/\rho_{wm}$	$= 35\ 767\ 137.16\ \text{m}^3/\text{h}$		
		$= 9\ 935.32\ \text{m}^3/\text{s}$		
	Wet air flow through air inlet, G_{w1}	$= G_a \times (1 + x_1)/\rho_{w1}$		
	Therefore, G_{w1}	$= 34\ 843\ 573.16\ \text{m}^3/\text{h}$		
		$= 9\ 678.770\ \text{m}^3/\text{s}$		
	Density difference, $\Delta\rho$	$= \rho_1 - \rho_2$		
	or $\Delta\rho$	$= 0.028\ \text{kg/m}^3$		
	At this stage the diameter of the NDCT will be required to estimate the pressure drops and use the draught equation and as the dimensions of the NDCT are not known, we need to make an initial assumption of the base/sill diameter and the H/Φ ratio. The H/Φ ratio specified in India based on structural design considerations is between 1.2 and 1.5. The choice of H/Φ ratio is dependent on many considerations like design wind speed for structural design, construction costs, cost of fill, client preferences, etc lets us assume an average H/Φ or H_d/Φ_f (draught height/fill diameter) ratio of 1.35 for this solved example.			

SI No.	Solved Example of a NDCT Thermic Design for Sea Water Application				
	Iteration 1		Iteration 2		
	Assume an initial value of base/sill diameter of the NDCT, Φ_B	= 100 m			= 124.11 m
	Now, it follows that the diameter at the top of air inlet, Φ_{ai}	= $\Phi_B - 2 \times H_1 \times \tan(\theta)$			
	θ = shell angle at the base, say 16.7°				
	Therefore, Φ_{ai}	= 94.78 m			= 118.89 m
	The ratio, Φ_{ai}/H_1	= 10.89			= 13.67
	The diameter of fill at midpoint or average fill diameter, Φ_f	= $\Phi_B - 2 \times (H_1 + FH/2 + SBD + MBD) \times \tan(\theta)$			
		= 93.79 m			= 117.90 m
	Area at this level of fill, A_{fill}	= 6 908.76 m ²			= 10 917.30 m ²
	Effective area of fill considering 10 percent obstructions to air flow, A_3	= 6 217.89 m ²			= 9 825.57 m ²
		= 66 894.50 ft ²			= 105 707.4 ft ²
	The afflux velocity through fill, v_{fill}	= G_{wm}/A_3			
		= 1.60 m/s			= 1.01 m/s
		= 314.46 FPM			= 199.00 FPM
	Effective Water Loading over the fill area, WL	= L/A_3			
		= 4.81 gpm/ft ²			= 3.04 gpm/ft ²
	Diameter at the drift eliminator level, Φ_{DE}	= $\Phi_f - 2 \times (FH/2 + SZ + ND + SBD) \times \tan(\theta)$			
		= 92.62 m			= 116.73 m
	Diameter of vena contracta, Φ_{vc}	= $(0.000 2 \times (\Phi_{ai}/H_1)^2 - 0.018 3 \times (\Phi_{ai}/H_1) + 0.860 1) \times \Phi_{ai}$			
	Therefore, Φ_{vc}	= 64.874 m			= 76.966 m
	Diameter at the throat level, Φ_T	= 62.874 m (say)			= 74.996 m
	The total pressure drop through the NDCT is required to be calculated to solve the draught equation. Hence, the individual velocity heads N_{vH} in each of the zones will have to be calculated using equations given at Annex A of the guideline.				

SI No.	Solved Example of a NDCT Thermic Design for Sea Water Application					
	N_{VH-ai}	$= 0.167 \times (\Phi_{ai}/H)^2$				
		$= 19.820$			$= 31.187$	
	$N_{VH-RZ+SZ}$	$= 0.16 \times (H_1 + SZ) \times L/G^{1.32}$				
	Here, H_1 and SZ are in feet					
		$= 11.275$			$= 11.275$	
	MC75 fill pressure drop as per Annex A of the guideline, Δp	$= (4.34 \times 10^{-08} \times v_{fill}^{2.355 \ 9} + 8.11 \times 10^{-07} \times v_{fill}^{1.540 \ 3} \times WL) \times (1 + 2.83 \times 10^{-01} \times FH) \times \rho_{wm}/1.2$				
	(Corrected for density)	$= 0.151$ inchWC			$= 0.049$ inchWC	
		$= 3.833$ mmWC			$= 1.257$ mmWC	
	Therefore, $N_{VH-Fill}$	$= \Delta p \times 2g/(\rho_{wm} \times v_{fill}^2)$				
		$= 26.353$			$= 21.573$	
	$N_{VH-C/B}$	$= 2.3$			$= 2.3$	
	N_{VH-DE}	$= 4.76 \times (\Phi_f/\Phi_{DE})^4$				
		$= 4.881$			$= 4.856$	
	$N_{VH-Throat}$	$= 1.01 \times (\Phi_f/\Phi_T)^4$				
		$= 5.001$			$= 6.179$	
	Therefore, total resistance through the NDCT, $N_{VH-Total}$	$= 69.630$			$= 77.370$	
	The total pressure drop through the NDCT Δp	$= \rho_{wm} \times N_{VH-Total} \times v_{fill}^2/2g$				
		$= 10.127$ mmWC			$= 4.506$ mmWC	
	Using the draught equation $H_d \times \Delta\rho = \Delta p$ we get $H_d \times \Delta\rho$	$= 1.35 \times \Phi_f \times \Delta\rho$				
		$= 3.586$ kg/m ²			$= 4.508$ kg/m ²	
	The base/sill diameter of the NDCT shall be iterated upon until the LHS and RHS values match closely (as in iteration 2).					
	H_d	$= 159.11$ m				

SI No.	Solved Example of a NDCT Thermic Design for Sea Water Application						
	It shall be noted that this manual method of solving the thermic problem was possible only because the fill selected did not have velocity as a variable in its KaV/L equation. For fills with velocity as a variable an initial assumption of diameter Φ_B is to be made at the KaV/L calculation stage itself and further iterations carried out. With multiple values to guess at the initial stage, a program in excel will be necessary to solve the thermic problem quickly.						
	Total height of NDCT above sill, $H_T = H_d + FH/2 + SBD + MBD + H_1$						
	H_T	= 169.462 m					
	Basin dia at sill, Φ_B	= 124.11 m					
viii)	Check for heat balance:						
	$(L \times C_p \times \text{range}) + (E_v \times C_p \times T_2) = G_a \times \Delta h$						
	$E_v = (x_2 - x_1) \times G_a$						
	Therefore, E_v						
	= 1 077 577.083 kg/h						
	The LHS of the equation will be						
	= 691 951 435.8 kcal/h						
	and the RHS of the equation will be						
	= 691 951 435.8 kcal/h						
ix)	In situations where the end user/EPC contractor wants to cross check any NDCT contractor's design received as part of a bidding process, the iterations on the base diameter shown at 7 above will not apply because the base diameter and the NDCT height are declared by the NDCT contractor in his bid. In such cases the end user/EPC Contractor can directly use the base diameter declared by the NDCT contractor and procedure with pressure drop calculations and draught balance.						

ANNEX D

(Foreword)

COMMITTEE COMPOSITION

Special Structures Sectional Committee, CED 38

<i>Organization</i>	<i>Representative(s)</i>
VMS Consultants Private Limited, Mumbai	MS ALPA SHETH (Chairperson)
Assystem Stup Consultants Limited, Mumbai	SHRI RAMESH BABU V.
Bharat Heavy Electricals Limited, New Delhi	DR ANIMESH DAS SHRI K. M. MOHAMED MUNEER (<i>Alternate</i>)
Central Public Works Department, New Delhi	SHRI A. K. RAJDEV SHRI SAUROBH KUMAR (<i>Alternate</i>)
CSIR - Central Building Research Institute, Roorkee	DR ACHAL K. MITTAL SHRI S. K. SINGH (<i>Alternate</i>)
CSIR - Central Road Research Institute, New Delhi	DR RAJEEV GOEL SHRI G. K. SAHU (<i>Alternate</i>)
CSIR - Structural Engineering Research Centre, Chennai	DR S. PARIVALLAL DR AMAR PRAKASH (<i>Alternate I</i>) DR B. ARUN SUNDARAM (<i>Alternate II</i>) DR P. HARIKRISHNA (<i>Alternate III</i>)
Engineers India Limited, New Delhi	SHRI RAJANJI SRIVASTAVA DR SUDIP PAUL (<i>Alternate</i>)
GE Power India Private Limited, New Delhi	SHRI SANJAY ARORA
Indian Association of Structural Engineers, New Delhi	SHRI MANOJ MITTAL SHRI AMAN DEEP GARG
Indian Concrete Institute, Chennai	SHRI PARTHA GANGOPADHYAY SHRI P. S. PATANKAR (<i>Alternate</i>)
Indian Institute of Technology Bombay, Mumbai	DR RAVI SINHA DR SIDDHARTHA GHOSH (<i>Alternate</i>)
Indian Institute of Technology Delhi, Delhi	DR DIPTI RANJAN SAHOO DR A. K. JAIN (<i>Alternate</i>)
Indian Institute of Technology Kanpur, Kanpur	DR SUDHIR MISRA DR NIHAR RANJAN PATRA (<i>Alternate</i>)
Indian Institute of Technology Madras, Chennai	DR A. MEHAR PRASAD DR C. V. R. MURTY (<i>Alternate I</i>) DR ARUL JAYACHANDRAN (<i>Alternate II</i>) DR AMLAN K. SENGUPTA (<i>Alternate III</i>)
Indian Institute of Technology Roorkee, Roorkee	DR PRAMOD KUMAR GUPTA DR M. A. IQBAL (<i>Alternate</i>)

<i>Organization</i>	<i>Representative(s)</i>
Indian Society for Structural Engineers, Mumbai	DR MOHUA CHAKRABORTY SHRI HEMANT VADALKAR (<i>Alternate</i>)
Institute for Steel Development & Growth, Kolkata	SHRI ARIJIT GUHA SHRI P. L. RAO (<i>Alternate</i>)
Invictus Consultancy Services, Mumbai	SHRI A. S. OUNDHAKAR
Larsen and Toubro Limited, Chennai	REPRESENTATIVE
M. N. Dastur Company Private Limited, Kolkata	SHRI TATHAGATA DASGUPTA SHRI KALYAN GOSWAMI (<i>Alternate</i>)
MECON Limited, Ranchi	SHRI J. K. JHA SHRI ABHINAV BHARAT JHA (<i>Alternate</i>)
National Disaster Management Authority, New Delhi	REPRESENTATIVE
National Institute of Technology Karnataka, Surathkal	DR B. R. JAYALEKSHMI
NBCC (India) Limited, New Delhi	SHRI R. P. MISHRA SHRI NAND KISHOR RAM (<i>Alternate</i>)
NTPC Limited, New Delhi	SHRI H. K. RAMKUMAR DR PRAVEEN KHANDELWAL (<i>Alternate</i>)
Nuclear Power Corporation of India Limited, Mumbai	SHRI G. PRABHAKAR
Paharpur Cooling Tower Limited, Kolkata	SHRI SANTANU CHATTERJEE SHRI RAJAT BHAUMIK (<i>Alternate</i>)
Tandon Consultants Private Limited, New Delhi	PROF MAHESH TANDON SHRI VINAY GUPTA (<i>Alternate</i>)
Visvesvaraya National Institute of Technology, Nagpur	DR O. R. JAISWAL DR RATNESH KUMAR (<i>Alternate</i>)
VMS Engineering Design Services Private Limited, Mumbai	ER EJAZ KHAN
In Personal Capacity [<i>C-401, Greenfield Tower CHS, Kadamwadi, Vakola Santacruz (East), Mumbai</i>]	SHRI V. N. HEGGADE
In Personal Capacity [<i>36 old Sneh Nagar, Wardha Road, Nagpur</i>]	DR L. K. JAIN
In Personal Capacity [<i>Block 2, Flat 2A, Rani Meyyammai Towers, MRC Nagar, RA Puram, Chennai</i>]	DR V. KALYANARAMAN

<i>Organization</i>	<i>Representative(s)</i>
BIS Directorate General	SHRI DWAIPIYAN BHADRA, SCIENTIST 'E'/ DIRECTOR AND HEAD (CIVIL ENGINEERING) (REPRESENTING DIRECTOR GENERAL (<i>Ex-officio</i>])

Member Secretaries
SHRI ASHOK SARAN
SCIENTIST 'B'/ASSISTANT DIRECTOR

AND

SHRI PRASHANT YADAV
SCIENTIST 'B'/ASSISTANT DIRECTOR

AND

SHRI ABHISHEK PAL
SCIENTIST 'D'/JOINT DIRECTOR
(CIVIL ENGINEERING), BIS

Bins, Silos and Concrete Cooling Towers Subcommittee, CED 38 : 1

<i>Organization</i>	<i>Representative(s)</i>
In Personal Capacity [<i>C-401, Greenfield tower CHS, Kadamwadi, Vakola Santacruz (East), Mumbai</i>]	SHRI V. N. HEGGADE (<i>Convener</i>)
Assystem Stup Consultants Limited, Mumbai	SHRI RAMESH BABU V.
CSIR - Structural Engineering Research Centre, Chennai	DR P. HARIKRISHNA SHRI V. RAMESH KUMAR (<i>Alternate I</i>) DR KANCHANA DEVI (<i>Alternate II</i>)
Invictus Consultancy Services, Mumbai	SHRI A. S. OUNDHAKAR
Larsen and Toubro Construction Limited, Chennai	SHRI S. RATHINAVEL
Nuclear Power Corporation of India Limited, Mumbai	SHRI ARVIND SHRIVASTAVA SHRI M. K. NEMA (<i>Alternate</i>)
Paharpur Cooling Tower Limited, Kolkata	SHRI SANTANU CHATTERJEE SHRI RAJAT BHAUMIK (<i>Alternate</i>)
Spectrum Techno Consultants Private Limited, Navi Mumbai	SHRI UMESH K RAJESHIRKE SHRI UPENDRANATH BHUPAL (<i>Alternate</i>)
Tangent solutions India Private Limited, Hyderabad	SHRI KIRAN MADHAVI

Working Group for Cooling Towers, CED 38 : 1/WG02

<i>Organization</i>	<i>Representative(s)</i>
In Personal Capacity [C-401, Greenfield tower CHS, Kadamwadi, Vakola Santacruz (East), Mumbai]	SHRI V. N. HEGGADE (Convener)
Spectrum Techno Consultants Private Limited, Navi Mumbai	SHRI UPENDRANATH BHUPAL (Co-Convener)
Assystem Stup Consultants Limited, Mumbai	SHRI RAMESH BABU V.
Hamon Shriram Cottrell Private Limited, Mumbai	SHRI SANDEEP DESHMUKH
Larsen and Toubro Construction Limited, Chennai	SHRI RAMADEVAN
Nuclear Power Corporation of India Limited, Mumbai	SHRI M. K. NEMA SHRI C. R. KAKADE (<i>Alternate I</i>) SHRI ARUNAVA SINHA (<i>Alternate II</i>)
Paharpur Cooling Tower Limited, Kolkata	SHRI VIKRAM SWARUP SHRI ARUL PRAKASH (<i>Alternate</i>)
SS Cooling Tower Limited, Mumbai	SHRI SURESH SARMA
Spectrum Techno Consultants Private Limited, Navi Mumbai	SHRI UMESH K. RAJESHIRKE
Tangent solutions India Private Limited, Mumbai	SHRI KIRAN MADHAVI
In Personal Capacity [14-A, Nandadeep, CHS, Sector 16-A, Vashi Navi Mumbai]	SHRI PARAG PATNI

(Continued from second cover)

This standard contributes to the UN Sustainable Development Goal 9: ‘Industry, innovation and infrastructure’, particularly its target to develop quality, reliable, sustainable and resilient infrastructure, and also promote inclusive and sustainable industrialization.

The composition of the Committee responsible for the formulation of this standard is given in [Annex D](#).

For the purpose of deciding whether a particular requirement of this standard is complied with, the final value, observed or calculated, expressing the result of a test or analysis, shall be rounded off in accordance with IS 2 : 2022 ‘Rules for rounding off numerical values (*second revision*)’. The number of significant places retained in the rounded off value should be the same as that of the specified value in this standard.

Bureau of Indian Standards

BIS is a statutory institution established under the *Bureau of Indian Standards Act, 2016* to promote harmonious development of the activities of standardization, marking and quality certification of goods and attending to connected matters in the country.

Copyright

BIS has the copyright of all its publications. No part of these publications may be reproduced in any form without the prior permission in writing of BIS. This does not preclude the free use, in the course of implementing the standard, of necessary details, such as symbols and sizes, type or grade designations. Enquiries relating to copyright be addressed to the Head (Publication & Sales), BIS.

Review of Indian Standards

Amendments are issued to standards as the need arises on the basis of comments. Standards are also reviewed periodically; a standard along with amendments is reaffirmed when such review indicates that no changes are needed; if the review indicates that changes are needed, it is taken up for revision. Users of Indian Standards should ascertain that they are in possession of the latest amendments or edition by referring to the website-www.bis.gov.in or www.standardsbis.in.

This Indian Standard has been developed from Doc No.: CED 38 (21888).

Amendments Issued Since Publication

Amend No.	Date of Issue	Text Affected

BUREAU OF INDIAN STANDARDS

Headquarters:

Manak Bhavan, 9 Bahadur Shah Zafar Marg, New Delhi 110002

Telephones: 2323 0131, 2323 3375, 2323 9402

Website: www.bis.gov.in

Regional Offices:

	Telephones
Central : 601/A, Konnectus Tower -1, 6 th Floor, DMRC Building, Bhavbhuti Marg, New Delhi 110002	{ 2323 7617
Eastern : 8 th Floor, Plot No 7/7 & 7/8, CP Block, Sector V, Salt Lake, Kolkata, West Bengal 700091	{ 2367 0012 2320 9474
Northern : Plot No. 4-A, Sector 27-B, Madhya Marg, Chandigarh 160019	{ 265 9930
Southern : C.I.T. Campus, IV Cross Road, Taramani, Chennai 600113	{ 2254 1442 2254 1216
Western : 5 th Floor/MTNL CETTM Technology Street, Hiranandani Gardens, Powai, Mumbai - 400076	{ 283 25838

Branches : AHMEDABAD, BENGALURU, BHOPAL, BHUBANESHWAR, CHANDIGARH, CHENNAI, COIMBATORE, DEHRADUN, DELHI, FARIDABAD, GHAZIABAD, GUWAHATI, HARYANA (CHANDIGARH), HUBLI, HYDERABAD, JAIPUR, JAMMU, JAMSHEDPUR, KOCHI, KOLKATA, LUCKNOW, MADURAI, MUMBAI, NAGPUR, NOIDA, PARWANOO, PATNA, PUNE, RAIPUR, RAJKOT, SURAT, VIJAYAWADA.