



भारतीय मानक ब्यूरो

(उपभोक्ता मामले, खाद्य एवं सार्वजनिक वितरण मंत्रालय, भारत सरकार)

BUREAU OF INDIAN STANDARDS

(Ministry of Consumer Affairs, Food & Public Distribution, Govt. of India)

मानक भवन, 9, बहादुर शाह ज़फर मार्ग, नई दिल्ली - 110002

Manak Bhawan, 9, Bahadur Shah Zafar Marg, New Delhi - 110002

Phones: 23230131 / 2323375 / 23239402

Website: www.bis.gov.in, www.manakonline.in

व्यापक परिचालन मसौदा

हमारा संदर्भ : सीईडी 20/टी-14

03 जुलाई 2024

तकनीकी समिति : लकड़ी और अन्य लिग्नोसेल्युलॉसिक उत्पाद अनुभागीय समिति , सीईडी 20

प्राप्तकर्ता :

- सिविल अभियांत्रिकी विभाग परिषद, सीईडीसी के सभी सदस्य
- लकड़ी और अन्य लिग्नोसेल्युलॉसिक उत्पाद अनुभागीय समिति , सीईडी 20 के सभी सदस्य
- रुचि रखने वाले अन्य निकाय।

महोदय/महोदया,

निम्नलिखित मानक का मसौदा संलग्न है:

प्रलेख संख्या	शीर्षक
सीईडी 20(26076)WC	लकड़ी और अन्य लिग्नोसेल्युलॉसिक सामग्री के पार्टिकल बोर्ड - विशिष्टता (आई एस 3087 का तीसरा पुनरीक्षण) (आई एस 12823 और आई एस 3097 का सम्मिश्रण) (आई सी एस संख्या : 790.060.20)

कृपया इस मसौदे का अवलोकन करें और अपनी समितियाँ यह बताते हुए भेजे कि यह मसौदा प्रकाशित हो तो इन पर अमल करने में आपको व्यवसाय अथवा कारोबार में क्या कठिनाइयां आ सकती हैं।

समितियाँ भेजने की अंतिम तिथि: 03 सितम्बर 2024

समिति यदि कोई हो तो कृपया अधोहस्ताक्षरी को ई-मेल द्वारा ced20@bis.gov.in पर या उपरलिखित पते पर, संलग्न फॉर्मेट में भेजें। समितियाँ बीआईएस ई-गवर्नेंस पोर्टल, www.manakonline.in के माध्यम से ऑनलाइन भी भेजी जा सकती हैं।

यदि कोई समिति प्राप्त नहीं होती है अथवा समिति में केवल भाषा संबंधी त्रुटि हुई तो उपरोक्त प्रालेख को यथावत अंतिम रूप दे दिया जाएगा। यदि समिति तकनीकी प्रकृति की हुई तो विषय समिति के अध्यक्ष के परामर्श से अथवा उनकी इच्छा पर आगे की कार्यवाही के लिए विषय समिति को भेजे जाने के बाद प्रालेख को अंतिम रूप दे दिया जाएगा।

यह प्रालेख भारतीय मानक ब्यूरो की वेबसाइट www.bis.gov.in पर भी उपलब्ध है।

धन्यवाद।

भवदीय

ह/-

द्वैपायन भद्र

वैज्ञानिक ई एवं प्रमुख

सिविल अभियांत्रिकी विभाग

संलग्न: उपरलिखित



भारतीय मानक ब्यूरो

(उपभोक्ता मामले, खाद्य एवं सार्वजनिक वितरण मंत्रालय, भारत सरकार)

BUREAU OF INDIAN STANDARDS

(Ministry of Consumer Affairs, Food & Public Distribution, Govt. of India)

मानक भवन, 9, बहादुर शाह ज़फर मार्ग, नई दिल्ली - 110002

Manak Bhawan, 9, Bahadur Shah Zafar Marg, New Delhi - 110002

Phones: 23230131 / 2323375 / 23239402

Website: www.bis.gov.in, www.manakonline.in

WIDE CIRCULATION DRAFT

Our Reference: CED 20/T-14

03 July 2024

**TECHNICAL COMMITTEE: WOOD AND OTHER LIGNOCELLULOSIC PRODUCTS
SECTIONAL COMMITTEE, CED 20**

ADDRESSED TO:

1. All Members of Civil Engineering Division Council, CEDC
2. All Members of Wood And Other Lignocellulosic Products Sectional Committee, CED 20 and its Subcommittees
3. All others interested.

Dear Sir/Madam,

Please find enclosed the following draft:

Doc No.	Title
CED 20(26076)WC	PARTICLE BOARDS OF WOOD AND OTHER LIGNOCELLULOSIC MATERIALS FOR GENERAL PURPOSE – SPECIFICATION (Third Revision of IS 3087) (Amalgamating IS 3097 and IS 12823) ICS 91.100.30

Kindly examine the attached draft and forward your views stating any difficulties which you are likely to experience in your business or profession, if this is finally adopted as National Standard.

Last Date for comments: 03 September 2024

Comments if any, may please be made in the enclosed format and emailed at ced20@bis.gov.in or sent at the above address. Additionally, comments may be sent online through the BIS e-governance portal, www.manakonline.in.

In case no comments are received or comments received are of editorial nature, kindly permit us to presume your approval for the above document as finalized. However, in case comments, technical in nature are received, then it may be finalized either in consultation with the Chairman, Sectional Committee or referred to the Sectional Committee for further necessary action if so desired by the Chairman, Sectional Committee.

The document is also hosted on BIS website www.bis.gov.in.

Thanking you,

Yours faithfully,

Sd/-

Dwaipayan Bhadra

Scientist 'E' & Head

Civil Engineering Department

Encl: As above

FORMAT FOR SENDING COMMENTS ON THE DOCUMENT

[Please use A4 size sheet of paper only and type within fields indicated. Comments on each clause/sub-clause/ table/figure, etc, be stated on a fresh row. Information/comments should include reasons for comments, technical references and suggestions for modified wordings of the clause. Comments through e-mail to ced20@bis.gov.in shall be appreciated.]

Doc. No.: CED 20(26076)WC

BIS Letter Ref: CED 20/T-14

Title: PARTICLE BOARDS OF WOOD AND OTHER LIGNOCELLULOSIC MATERIALS FOR GENERAL PURPOSE – SPECIFICATION *(Third Revision of IS 3087) (Amalgamating IS 3097 and IS 12823)*

Last date of comments: 03 September, 2024

Name of the Commentator/ Organization: _____

Sl No.	Clause/ Para/ Table/ Figure No. commented	Type of Comment (General/ Technical/ Editorial)	Comments/ Modified Wordings	Justification of Proposed Change

NOTE- Kindly insert more rows as necessary for each clause/table, etc

BUREAU OF INDIAN STANDARDS

DRAFT FOR COMMENTS ONLY

(Not to be reproduced without the permission of BIS or used as an Indian Standard)

Draft Indian Standard

**PARTICLEBOARDS OF WOOD AND OTHER LIGNOCELLULOSIC MATERIALS –
SPECIFICATION**

*(Third Revision of IS 3087)
(Amalgamating IS 3097 and IS 12823)
(ICS 79.060.20)*

**Wood and Other Lignocellulosic
Products Sectional Committee, CED 20**

Last Date of comments – 03 September, 2024

FOREWORD

(Formal clauses will be added later)

Particleboard is a panel product manufactured from wood or other lingo- cellulosic particles combined with synthetic resin and other additives. The panels are manufactured by the application of heat and pressure by a process in which the inter-particle bond is substantially created by the added binder. Other materials may be added during manufacturing to improve certain properties.

This standard was first published in 1965 and the subsequently revised in 1985 and 2005. In this revision, the Indian Standards that is, IS 3087, IS 3097 and IS 12823 have been merged under single Indian Standards IS 3087, the following major modifications have been incorporated:

- a) Scope and content of the standard has been modified with inclusion of uncoated, prelaminated and veneered particleboards;
- b) Particleboards have been classified based on uses and service conditions;
- c) Requirements have been modified/added against each classification of the uncoated particleboards; and
- d) Marking clause has been modified

Particleboards are recommended for use in interior locations. HMR Grade particleboards may be used in Humid tropical wet conditions with load bearing applications, whereas MR Grade particleboards may be used in Humid Conditions subtropical and tropical dry and Regular grade may be used in Arid/ Semi-arid/temperate Conditions. This standard covers classification and requirements of particleboard for general purposes, furniture, load bearing and heavy duty load bearing applications. Surface wise it cover uncoated, prelaminated and veneered particleboards. In the prelaminated boards are further classified based on type of laminations as Type 1, Type 2, Type 3 and Type 4. And for veneered particleboard the surface wise classification as Type 1 and Type 2.

This standard gives restriction on formaldehyde release in the form of formaldehyde content and formaldehyde emission requirements. Both formaldehyde content and emission can have requirements under Class E₁ and Class E₂. The Class E₁ is more stringent than Class E₂.

In formulation of this standard, due weightage has been given to standards and practices prevailing in different countries and also relating the same to the climatic conditions and requirements in our country.

A scheme of labelling environment friendly products known as ECO-Mark has been instituted at the instance of the Ministry of Environment, Forests and Climate Change, Government of India. The ECO-Mark is administered by the Bureau of Indian Standards (BIS) under the Bureau of Indian Standards Act, 2016 as per the Resolution No. 71 dated 21st February 1991 and Resolution No. 425 dated 20 October 1992 published in the Gazette of the Government of India. For a product to be eligible for ECO-Mark, it shall also carry the Standard Mark (ISI mark) of BIS besides meeting. For this purpose, the Standard Mark of BIS would be a single mark being a combination of the ISI Mark and the Eco logo. Requirements to be satisfied for a product to qualify for the BIS Standard Mark for Eco friendliness will be optional. Manufacturing units will be free to opt for ISI Mark alone also.

The ECO criteria are based on the Gazette Notification No. 170 dated 16 May 1996 for wood substitutes as environment friendly products published in the Gazette of Government of India, as revised/amended from time to time.

For the purpose of deciding whether a particular requirement of this standard is complied with, the final value, observed or calculated, expressing the result of a test or analysis, shall be rounded off in accordance with IS 2: 2022 'Rules for rounding off numerical values (second revision)'. The number of significant places retained in the rounded off value should be the same as that of the specified value in this standard.

Draft Indian Standard

**PARTICLEBOARDS OF WOOD AND OTHER LIGNOCELLULOSIC MATERIALS –
SPECIFICATION**

*(Third Revision of IS 3087)
(Amalgamating IS 3097 and IS 12823)*

1 SCOPE

This standard covers classification and requirements of particleboard for general purposes, furniture, load bearing and heavy duty load bearing applications. It includes uncoated, prelaminated and veneered particleboards.

2 REFERENCES

The standards listed in Annex A contain provisions which through reference in this text, constitute the provision of this standard. At the time of publication, the editions indicated were valid. All standards are subject to revision and parties to agreements based on this standard are encouraged to investigate the possibility of applying the most recent editions of the standards indicated in Annex A.

3 TERMINOLOGY AND ABBREVIATED TERMS

3.1 Terminology – For purpose of this standard, the definitions given in IS 707 shall apply.

3.2 Abbreviated Terms – For the purposes of this document, the following abbreviated terms apply.

- | | | | |
|----|-----|---|-------------------------------|
| a) | FN | – | Furniture |
| b) | GP | – | General purpose |
| c) | HLB | – | Heavy-duty load bearing |
| d) | LB | – | Load bearing |
| e) | MR | – | Moisture resistant — tropical |
| f) | P | – | Particleboard |
| g) | PLB | – | Prelaminated particleboard |
| h) | REG | – | Regular |
| i) | VPB | – | Veneered particleboard |

4 CLASSIFICATIONS MATRICES

4.1 Classification matrices on uncoated particleboard include major application categories, service conditions etc., are shown in **Table 1**.

TABLE 1 CLASSIFICATION MATRIX FOR PARTICLEBOARDS
(Clauses 4)

SI No.	Type	Service Conditions		
		Dry Conditions Arid/ Semi-arid/ temperate (Regular Grade)	Humid Conditions subtropical and Tropical dry (MR Grade)	High Humid conditions Tropical wet (HMR Grade)
(1)	(2)	(3)	(4)	(5)
i)	GP	REG general purpose	MR general purpose	HMR general purpose
	Application examples	General uses veneer grade	General uses	General uses
ii)	FN	REG furniture grade	MR furniture grade	HMR furniture grade
	Application examples	Carcass, furniture, cabinets, substrate for any decorative finish	Cabinets for kitchen and bathroom moulded chair and table	Cabinets for kitchen and bathroom moulded chair and table
iii)	LB	REG load bearing	MR load bearing	HMR load bearing
	Application examples	Domestic flooring, shelving, general construction	Domestic flooring, shelving, roof decking wall sheathing, general construction	Domestic flooring, shelving, roof decking wall sheathing, general construction
iv)	HLB	REG heavy-duty load bearing	MR heavy duty load bearing	--
	Application examples	Industrial flooring shelving	Industrial flooring shelving	--

NOTE - When a product is used in a load-bearing or structural application, as and when desired, additional information shall be available by the manufacturer in the form of characteristic values derived from different structural testing (see IS 2380). Also, experimental test results or history of use to validate its performance under the proposed conditions.

4.2 Prelaminated Particleboard – For prelaminated particleboard, each of the grade and type specified in 4.1 shall further classified in four surface types based on the surface abrasion characteristics, that is, Type 1, 2, 3 and 4.

NOTE - Type 1 is useful for restaurant table top application. Type 2 is useful for horizontal applications like cash counters and office tabletops. Type 3 is useful for normal horizontal applications like office tabletops and domestic furniture tops. Type 4 is for less contact/ less traffic area/ less abrasion area may be for vertical application only.

4.3 Veneered Particleboard – For veneered particleboard, each of the grade and type specified in 4.1 shall further classified in two surface types.

a) Type 1 - *Veneered particleboards, solid core, general purpose* – These are veneered particleboards of solid core with faces of veneer of general purpose type.

b) Type 2– *Veneered particleboard, solid core, decorative* – These are veneered particleboards with solid core but faced on one side or on both sides with decorative veneers.

4.4 Formaldehyde Classes – In terms of formaldehyde class, each particleboard shall be further classified in two classes as follows:

- a) Formaldehyde Class, E_1
- b) Formaldehyde Class, E_2

5 MATERIALS

5.1 Timber Species

Any species of timber may be used for manufacturer of particleboard. It is recommended to use wood from sources other than natural forests includes, Tree Outside Forest (TOF), rubber, coconut, cashew, walnut, agroforestry, farm forestry, industrial and social forestry plantations, etc and shade trees from tea and coffee estates in particleboard manufacturing.

For ECO-mark, only species of wood from sources other than natural forests includes, Tree Outside Forest (TOF), rubber, coconut, cashew, walnut, agroforestry, farm forestry, industrial and social forestry plantations, etc and shade trees from tea and coffee estates shall be used for the manufacturer of particleboard.

5.2 Adhesive

Any suitable type of resin adhesive may be used for the purpose of bonding so that the boards comply with physical, mechanical and formaldehyde release requirements given in this standard.

5.3 Sizing Material

Paraffin wax dissolved in mineral spirit or alternatively emulsified with water, or melted shall be used as sizing material.

5.4 Base Paper – A printed or plain coloured absorbent paper normally having a weight of 60 g/m² to 140 g/m² used in manufacturing of prelaminated particleboard.

5.5 Impregnated Base Paper (IBP) – A base paper, printed or plain coloured, impregnated in any suitable synthetic resin and dried to a volatile content of 4 percent to 8 percent used in manufacturing of prelaminated particleboard.

5.6 Impregnated Overlay – An overlay paper is impregnated in any suitable synthetic resin and dried to a volatile content of 4 percent to 8 percent used in manufacturing of prelaminated particleboard.

5.7 Overlay Paper – A highly absorbent tissue paper having a weight of 18 g/m² to 40 g/m² used in manufacturing of prelaminated particleboard.

5.8 Species of Timber for Veneers in Veneered Particleboard

Timbers for face veneers of general purpose type veneered particleboards and for cross-bands where used in all types and grades of veneered particleboards, shall be as per IS 303 and IS 1328.

5.9 Adhesive for Bonding of Veneer

The adhesives used for bonding veneer shall be conforming to relevant grade of IS 848 for requisite service conditions.

5.10 Preservative

A suitable preservative may be added to the mix at the mixing stage of adhesive. The following preservatives are regarded as suitable and their percentage is given on the basis of oven dry weight of the particles.

- a) Sodium pentachlorophenate to the extent of 2 percent; and
- b) Trichlorophenol to the extent of 5 percent.

6 MANUFACTURE

6.1 Uncoated Particleboard

6.1.1 Particles of wood or other lignocellulosic materials for the manufacture of particleboards shall be produced by cutting wood and/or any other suitable ligno-cellulosic materials into shavings, flakes or splinters on a suitable chipping machine. The particles shall be dried in a mechanical drier. The dried particles shall be graded to required sizes and thoroughly blended with the requisite quantity of adhesives in mechanical mixers or applicators. The required sizing material may be added at this stage, either mixed with the binder or separately introduced into the mixer. Care shall be taken that the moisture content of the binder does not excessively increase the moisture content of the chips. The well-blended chips are then formed into a mat and pressed into panels by passing into the multi daylight press under controlled heat, pressure and time conditions. The hot-pressed boards are subsequently cooled, conditioned to attain equilibrium moisture content and sanded on both sides to attain uniform thickness and finally trimmed and cut to standard sizes.

6.1.2 In case of multi-layer particleboards, the construction shall be well-balanced about the central plane. In case of a single-layer particleboard, the particles shall be uniformly laid. Care shall be taken that no asymmetric grading of chips takes place.

6.2 Prelaminated Particleboards

6.2.1 For making prelaminated particleboards, uncoated particleboards having superfine and closed surface with high face strength and steep density gradient across the thickness is used. Impregnated base papers rich in synthetic resin are placed on either side of the particleboard and the assembly is taken inside a short cycle single opening lamination press or a multiday light press. Under heat and pressure, the resin flows and forms a permanent bond with particleboard.

6.2.2 The top surface of impregnated paper comes in contact with special surfaced chromium plates or steel caul plates and takes the Impression of surface finish of these caul plates. Hot boards are extracted out of the short cycle press and cooled in air, whereas cooling of boards is done inside the press in multiday light type.

6.2.3 Care shall be taken to keep cycle times low in the press to avoid heat penetration to the centre of the board edge.

6.2.4 The impregnated overlay paper may be used by placing it over the impregnated base paper (IBP) on one surface while using a normal IBP on the other surface and pressed under the influence of heat and pressure. The impregnated overlay becomes transparent after pressing. Such boards are used for high surface abrasion applications.

6.2.5 The finish of the paper overlaid board depends on the surface of caul plates used. Common surface finishes in use are glossy, matt textured (soft, swede, wood pore and leather), etc.

6.3 Veneered Particleboard

6.3.1 *Preservative Treatment of Veneers* – Veneers of timber shall be given a preservative treatment at the veneer stage as specified in IS 303.

6.3.2 Trimmed and cut ends of the finished veneered particleboard shall be given a protective treatment by coating with any of the following preservatives:

- a) Sodium pentachlorophenate or trichlorophenol to a retention level of 6 kg/m³ or 8 kg/m³ respectively; or
- b) 10 percent solution of copper naphthenate in mineral spirit; or
- c) Shellac in spirit or phenol formaldehyde.

NOTE – Other type and method of preservative treatment may also be done as per agreement between manufacturer and purchaser and shall be declared by the manufacturer.

6.3.3 Particleboards used as core shall be treated as and when required.

6.3.4 *Cross-Band and Veneer*

The construction shall be well-balanced around the central line. When only one side is provided with decorative face, the back face shall be so designed with material and thickness as to balance the stress likely to be developed in the face veneers.

6.3.5 Cross-band, where used, shall neither be less than 1.0 m nor more than 3.0 mm in thickness. Face veneers shall be between 0.5 mm and 1.6 mm in thickness for commercial veneers and 0.5 mm to 1.0 mm in thickness for decorative veneers. The veneers shall be of uniform thickness within a tolerance of ± 5 percent.

6.3.6 The decorative veneers shall be spliced or taped at the edges. The joining of veneers shall be such as to develop a decorative match to obtain the required match in figure on the spliced or taped veneers. The veneers may have end-grain joints in cases of special matching like centre-matching, V-matching, etc.

6.3.7 Cross-bands, where used, shall be laid in such a manner that there are no gaps exceeding 0.8 mm and no overlaps. The cross-bands shall be free from dry rot and dead knots.

6.3.8 The veneers used shall have moisture content not exceeding 14 percent and the veneered particleboard after pressing shall be conditioned to a moisture content of not less than 5 percent and not more than 15 percent.

6.3.9 In case of 5-ply veneered particleboards, the face veneers shall be made with its grain direction at right angles to the grain direction of the cross-bands. In all cases, the grains on both the faces of the assembled board shall run in the same direction.

6.3.10 Veneered particleboards shall be made either by gluing particleboards between the veneer or alternatively, between two sheets of plywood, but the total thickness of the skin of either side shall not exceed 5 mm. The thickness of the two skins shall be equal and uniform if the same species is used and no other provision is made for balanced construction. The adhesive used for either gluing the skin or gluing the plywood shall conform to IS 303 for the various grades.

7 FINISH

7.1 The uncoated particleboards shall be of uniform thickness and uniform density throughout the length and width of the boards. All particleboards shall be flat. Both surfaces of the particleboard shall be sanded to a smooth finish.

7.2 The finish of the lamination shall be of uniform nature. The finish of the paper overlaid board depends on the surface of caul plates used. Common surface finishes in use are glossy, matt, textured (soft, swede, wood pore and leather), etc.

7.3 All veneered particleboards shall be flat and squarely cut.

8.1 DIMENSIONS AND TOLERANCES

8.1. When tested in accordance with IS 2380 (Part 2), the dimensions of Particleboard shall be as follows:

Length, mm : 4 880, 3 660, 3 050, 2 745, 2 440, 2 135, 1 830, 1 525, 1220, 1 000 and 915

Width, mm : 1 830, 1525, 1220, 1000, 915, 610 and 305

Thickness, mm : 3, 4, 6, 9,11, 12, 15, 16, 17, 18, 22, 25, 30, 35, 40, 44 and 45 mm.

NOTE- Any other dimension as agreed to between the purchaser and the manufacturer may be used and the same shall be declared by the manufacturer.

8.2 The tolerance on dimensions of the individual panels shall be as give in Table 2.

TABLE 2 REQUIREMENTS FOR DIMENSIONS
(Clause 8.2)

SI No.	Properties	Requirement	Method of Test, Ref to
(1)	(2)	(3)	(4)
i)	Length	± 2 mm/m, Max. ± 5 mm	-
ii)	Width	± 2 mm/m, Max. ± 5 mm	-
iii)	Thickness, Sanded/Finished panel	± 0.3 mm	-
iv)	Squareness, Max.	2mm/m or 0.2 percent	Annex B
v)	Edge Straightness, Max.	2mm/m or 0.2 percent	Annex B

9 PHYSICAL AND MECHANICAL REQUIREMENTS

9.1 From each of the particleboard selected as in **10.1** following test specimens shall be cut out from portions 150 mm away from the edges for tests as specified in 9 and conditioned as specified in IS 2380 (Part 1).

a) For Determination of Density

Three test specimens 75 mm wide and 150 mm long, in full thickness of board from each sample. Other sizes of specimens may be used when deemed necessary.

b) For Determination of Moisture Content

Three test specimens 75 mm wide and 150 mm long, in full thickness of board from each sample. Smaller specimens may be used when deemed necessary.

c) For Swelling in Water Test

d) Three test specimens of size 200 mm x 100 mm in full thickness of board from each sample.

For Determination of Modulus of Rupture

Three test specimens from each sample as specified in IS 2380 (Part 4).

e) For Determination of Tensile Strength Perpendicular to Surface

Three test specimens of size 50 mm x 50 mm in full thickness of board from each sample.

f) For Determination of Tensile Strength Perpendicular to Surface

After Ageing Test Three test specimens of size 50 mm x 50 mm in full thickness of board from each sample.

g) For Determination of Screw Withdrawal Strength

Three test specimens from each sample of size as specified in IS 2380 (Part 14).

h) For Determining the Resistance to Abrasion

Three test specimens of size about 130 mm diameter or a square of about 120 mm with its corners rounded to give a diagonal of about 130 mm in full thickness of board from each sample.

j) For Determining the Resistance to Steam

Three test specimens of size 100 mm x 100 mm in full thickness of board from each sample.

k) For Determining the Resistance to Crack

Three test specimens of size 100 mm x 100 mm in full thickness of board from each sample.

m) For Determining the Resistance to Cigarette Burn

Three test specimens of size 200 mm x 10 mm in full thickness of board from each sample.

n) For Determining the Resistance to Stain

Three test specimens of size 75 mm x 25 mm in full thickness of board from each sample.

p) For Adhesion of Plies

9.2 Density variation and moisture content of the individual panels shall be within the maximum tolerances stated in Table 3.

TABLE 3 REQUIREMENTS FOR DENSITY VARIATION AND MOISTURE CONTENT
(Clause 9.2)

SI No.	Properties	Requirement	Method of Test, Ref to
(1)	(2)	(3)	(4)
i)	Density variation within panel, Max.	±10% max from mean	IS 2380 (Part 3)
ii)	Moisture content	5 to 15 percent	IS 2380 (Part 3)

9.3 GP REG Grade particleboard shall conform to the requirements given in Table 4.

TABLE 4 REQUIREMENTS FOR GP REG PARTICLEBOARD
(Clause 9.3)

SI No.	Properties	Requirement Thickness ranges mm, nominal									Method of Test, Ref to
		≤3	>3 to ≤4	>4 to ≤6	>6 to ≤13	>13 to ≤20	>20 to ≤25	>25 to ≤32	>32 to ≤40	>40	
(1)	(2)	(3)	(4)	(5)	(6)	(7)	(8)	(9)	(10)	(11)	(12)
i)	Bending strength (MoR), MPa, Min.	12	12	13	13	12	11	10	7.0	5.5	IS 2380 (Part 4)
ii)	Internal bond strength, MPa, Min.	0.35	0.35	0.30	0.28	0.24	0.20	0.17	0.14	0.14	IS 2380 (Part 4)
iii)	24h thickness swelling, percent, Max.	26	24	23	18	15	13	13	12	12	IS 2380 (Part 4)
iv)	Screw withdrawal Face, N, Min.	1250									IS 2380 (Part 14)
v)	Screw withdrawal Edge, N, Min.	---				700					IS 2380 (Part 14)

9.4 FN REG Grade particleboard shall conform to the requirements given in Table 5.

TABLE 5 – REQUIREMENTS FOR FN REG PARTICLEBOARD
(Clause 9.4)

SI No.	Properties	Requirement Thickness ranges mm, nominal									Method of Test, Ref to
		≤3	>3 to ≤4	>4 to ≤6	>6 to ≤13	>13 to ≤20	>20 to ≤25	>25 to ≤32	>32 to ≤40	>40	
(1)	(2)	(3)	(4)	(5)	(6)	(7)	(8)	(9)	(10)	(11)	(12)
i)	Bending strength (MoR), MPa, Min.	13.0	13.0	14.0	14.0	13.0	12	11	8	7.5	IS 2380 (Part 4)
ii)	Moduels of Elasticity (MoE), MPa, Min.	1800	1800	1900	1900	1900	1700	1400	1200	1200	IS 2380 (Part 4)
iii)	Internal bond strength, MPa, Min.	0.5	0.5	0.45	0.45	0.40	0.35	0.30	0.25	0.25	IS 2380 (Part 5)
iv)	Screw withdrawal Face, N, Min.	1250									IS 2380 (Part 14)

SI No.	Properties	Requirement Thickness ranges mm, nominal									Method of Test, Ref to
		≤3	>3 to ≤4	>4 to ≤6	>6 to ≤13	>13 to ≤20	>20 to ≤25	>25 to ≤32	>32 to ≤40	>40	
v)	Screw withdrawal Edge, N, Min.	---				700					IS 2380 (Part 14)

9.5 LB REG Grade particleboard shall conform to the requirements given in Table 6.

TABLE 6 REQUIREMENTS FOR LB REG PARTICLEBOARD

(Clause 9.5)

SI No.	Properties	Requirement Thickness ranges mm, nominal									Method of Test, Ref to
		≤3	>3 to ≤4	>4 to ≤6	>6 to ≤13	>13 to ≤20	>20 to ≤25	>25 to ≤32	>32 to ≤40	>40	
(1)	(2)	(3)	(4)	(5)	(6)	(7)	(8)	(9)	(10)	(11)	(12)
i)	Bending strength (MoR), MPa, Min.	16.0	18.0	19.0	17.0	16.0	14.0	12.0	9.0	9.0	IS 2380 (Part 4)
ii)	Moduels of Elasticity (MoE), MPa, Min.	1800	1950	2200	2200	2100	1900	1700	1200	1200	IS 2380 (Part 4)
iii)	Internal bond strength, MPa, Min.	0.50	0.45	0.45	0.40	0.35	0.30	0.25	0.20	0.20	IS 2380 (Part 5)
iv)	24h thickness swelling, percent, Max.	16	16	14	13	11	11	11	10	9	IS 2380 (Part 17)
v)	Screw withdrawal Face, N, Min.	1250									IS 2380 (Part 14)
vi)	Screw withdrawal Edge, N, Min.	---				700					IS 2380 (Part 14)

9.6 HLB REG Grade particleboard shall conform to the requirements given in Table 7.

TABLE 7 REQUIREMENTS FOR HLB REG PARTICLEBOARD

(Clause 9.6)

SI No.	Properties	Requirement Thickness ranges mm, nominal									Method of Test, Ref to
		≤3	>3 to ≤4	>4 to ≤6	>6 to ≤13	>13 to ≤20	>20 to ≤25	>25 to ≤32	>32 to ≤40	>40	
(1)	(2)	(3)	(4)	(5)	(6)	(7)	(8)	(9)	(10)	(11)	(12)
i)	Bending strength (MoR), MPa, Min.	18.0	20.0	21.0	21.0	19.0	18.0	16.0	14.0	13.0	IS 2380 (Part 4)
ii)	Moduels of Elasticity (MoE), MPa, Min.	2900	3000	3100	3000	2900	2700	2400	2200	2200	IS 2380 (Part 4)
iii)	Internal bond strength, MPa, Min.	0.80	0.75	0.75	0.75	0.70	0.65	0.60	0.45	0.40	IS 2380 (Part 5)
iv)	24h thickness swelling, percent, Max.	12	10	10	10	10	10	10	9	9	IS 2380 (Part 17)
v)	Screw withdrawal Face, N, Min.	1250									IS 2380 (Part 14)
vi)	Screw withdrawal Edge, N, Min.	---				700					IS 2380 (Part 14)

9.7 GP MR Grade particleboard shall conform to the requirements given in Table 8.

TABLE 8 REQUIREMENTS FOR GP MR PARTICLEBOARD

(Clause 9.7)

SI No.	Properties	Requirement Thickness ranges mm, nominal									Method of Test, Ref to
		≤3	>3 to ≤4	>4 to ≤6	>6 to ≤13	>13 to ≤20	>20 to ≤25	>25 to ≤32	>32 to ≤40	>40	
(1)	(2)	(3)	(4)	(5)	(6)	(7)	(8)	(9)	(10)	(11)	(12)
i)	Bending strength (MoR), MPa, Min.	15.0	15.0	14.0	13.0	11.0	10.0	10.0	7.0	5.5	IS 2380 (Part 4)
ii)	Internal bond strength, MPa, Min.	0.35	0.35	0.30	0.28	0.20	0.17	0.17	0.14	0.14	IS 2380 (Part 5)

SI No.	Properties	Requirement Thickness ranges mm, nominal									Method of Test, Ref to
		≤3	>3 to ≤4	>4 to ≤6	>6 to ≤13	>13 to ≤20	>20 to ≤25	>25 to ≤32	>32 to ≤40	>40	
(1)	(2)	(3)	(4)	(5)	(6)	(7)	(8)	(9)	(10)	(11)	(12)
iii)	24h thickness swelling, percent, Max.	20	16	14	12	12	10	10	9	8	IS 2380 (Part 17)
iv)	Screw withdrawal Face, N, Min.	1250									IS 2380 (Part 14)
v)	Screw withdrawal Edge, N, Min.	--					850				IS 2380 (Part 14)
vi)	Moisture Resistance:										
	Option1, cyclic test: Internal bond Strength, MPa, Min.	0.21	0.20	0.19	0.17	0.14	0.11	0.10	0.09	0.08	IS 2380 (Part 5) See Note
	Thickness swell, percent, percent, Max.	16	15	14	13	12	11	10	9	8	IS 2380 (Part 17)
	Option 2, boil test: Internal bond strength, MPa, Min.	0.16	0.15	0.15	0.14	0.12	0.09	0.08	0.07	0.06	IS 2380 (Part 5) See Note

9.8 FN MR Grade particleboard shall conform to the requirements given in Table 9.

TABLE 9 REQUIREMENTS FOR FN MR PARTICLEBOARD

(Clause 9.8)

SI No.	Properties	Requirement Thickness ranges mm, nominal									Method of Test, Ref to
		≤3	>3 to ≤4	>4 to ≤6	>6 to ≤13	>13 to ≤20	>20 to ≤25	>25 to ≤32	>32 to ≤40	>40	
(1)	(2)	(3)	(4)	(5)	(6)	(7)	(8)	(9)	(10)	(11)	(12)
i)	Bending strength (MoR), MPa, Min.	20.0	18.0	17.0	16.0	15.0	13.0	12.0	10.0	8.0	IS 2380 (Part 4)
ii)	Modulus of Elasticity (MoE), MPa, Min.	2300	2200	2100	2000	1900	1700	1600	1600	1400	IS 2380 (Part 4)

SI No.	Properties	Requirement Thickness ranges mm, nominal									Method of Test, Ref to
		≤3	>3 to ≤4	>4 to ≤6	>6 to ≤13	>13 to ≤20	>20 to ≤25	>25 to ≤32	>32 to ≤40	>40	
(1)	(2)	(3)	(4)	(5)	(6)	(7)	(8)	(9)	(10)	(11)	(12)
iii)	Internal bond strength, MPa, Min.	0.50	0.50	0.45	0.45	0.40	0.35	0.30	0.25	0.25	IS 2380 (Part 5)
iv)	24h thickness swelling, percent, Max.	18	16	14	12	12	10	10	9	8	IS 2380 (Part 17)
v)	Screw withdrawal Face, N, Min.	1250									IS 2380 (Part 14)
vi)	Screw withdrawal Edge, N, Min.	--				850					IS 2380 (Part 14)
vii)	Moisture Resistance:										
	Option1, cyclic test: Internal bond Strength, MPa, Min.	0.25	0.24	0.23	0.22	0.18	0.16	0.14	0.12	0.10	IS 2380 (Part 5) See Note
	Thickness swell, percent, percent, Max.	16	14	13	12	11	10	9	8	7	IS 2380 (Part 17)
	Option 2, boil test: Internal bond strength, MPa, Min.	0.24	0.23	0.22	0.22	0.20	0.17	0.15	0.14	0.12	IS 2380 (Part 5) See Note

9.9 LB MR Grade particleboard shall conform to the requirements given in Table 10.

TABLE 10 REQUIREMENTS FOR LB MR PARTICLEBOARD

(Clause 9.9)

SI No.	Properties	Requirement Thickness ranges mm, nominal									Method of Test, Ref to
		≤3	>3 to ≤4	>4 to ≤6	>6 to ≤13	>13 to ≤20	>20 to ≤25	>25 to ≤32	>32 to ≤40	>40	
(1)	(2)	(3)	(4)	(5)	(6)	(7)	(8)	(9)	(10)	(11)	(12)
i)	Bending strength (MoR), MPa, Min.	20.0	18.0	17.0	16.0	15.0	13.0	12.0	10.0	8.0	IS 2380 (Part 4)

SI No.	Properties	Requirement Thickness ranges mm, nominal									Method of Test, Ref to
		≤3	>3 to ≤4	>4 to ≤6	>6 to ≤13	>13 to ≤20	>20 to ≤25	>25 to ≤32	>32 to ≤40	>40	
(1)	(2)	(3)	(4)	(5)	(6)	(7)	(8)	(9)	(10)	(11)	(12)
ii)	Modulus of Elasticity (MoE), MPa, Min.	2300	2200	2100	2000	1900	1700	1600	1600	1400	IS 2380 (Part 4)
iii)	Internal bond strength, MPa, Min.	0.50	0.50	0.45	0.45	0.40	0.35	0.30	0.25	0.25	IS 2380 (Part 5)
iv)	24h thickness swelling, percent, Max.	18	16	14	12	12	10	10	9	8	IS 2380 (Part 17)
v)	Screw withdrawal Face, N, Min.	1250									IS 2380 (Part 14)
vi)	Screw withdrawal Edge, N, Min.	--				850					IS 2380 (Part 14)
vii)	Moisture Resistance:										
	Option1, cyclic test: Internal bond Strength, MPa, Min.	0.40	0.40	0.35	0.30	0.25	0.25	0.20	0.18	0.15	IS 2380 (Part 5) See Note
	Thickness swell, percent, percent, Max.	12	11	10	10	9	9	8	7	6	IS 2380 (Part 17)
	Option 2, boil test: Internal bond strength, MPa, Min.	0.30	0.28	0.28	0.28	0.20	0.17	0.15	0.13	0.12	IS 2380 (Part 5) See Note

9.10 HLB MR Grade particleboard shall conform to the requirements given in Table 11.

TABLE 11 REQUIREMENTS FOR HLB MR PARTICLEBOARD

(Clause 9.10)

SI No.	Properties	Requirement Thickness ranges mm, nominal						Method of Test, Ref to
		>6 to ≤13	>13 to ≤20	>20 to ≤25	>25 to ≤32	>32 to ≤40	>40	
(1)	(2)	(3)	(4)	(5)	(6)	(7)	(8)	(11)
i)	Bending strength (MoR), MPa, Min.	22,0	20,0	18,0	17,0	16,0	14,0	IS 2380 (Part 4)
ii)	Modulus of Elasticity (MoE), MPa, Min.	3 350	3 100	2 900	2 800	2 600	2 400	IS 2380 (Part 4)
iii)	Internal bond strength, MPa, Min.	0,75	0,70	0,65	0,60	0,50	0,45	IS 2380 (Part 5)
iv)	24h thickness swelling, percent, Max.	9	8	8	8	7	7	IS 2380 (Part 17)
v)	Screw withdrawal Face, N, Min.	1250						IS 2380 (Part 14)
vi)	Screw withdrawal Edge, N, Min.	--	850					IS 2380 (Part 14)
vii)	Moisture Resistance:							
	Option1, cyclic test: Internal bond Strength, MPa, Min.	0,45	0,42	0,39	0,36	0,33	0,30	IS 2380 (Part 5) See Note
	Thickness swell, percent, percent, Max.	10	9	9	8	7	6	IS 2380 (Part 17)
	Option 2, boil test: Internal bond strength, MPa, Min.	0,37	0,35	0,32	0,30	0,27	0,25	IS 2380 (Part 5) See Note

9.11 GP HMR Grade particleboard shall conform to the requirements given in Table 12.

TABLE 12 REQUIREMENTS FOR GP HMR PARTICLEBOARD
(Clause 9.11)

SI No.	Properties	Requirement Thickness ranges mm, nominal									Method of Test, Ref to
		≤3	>3 to ≤4	>4 to ≤6	>6 to ≤13	>13 to ≤20	>20 to ≤25	>25 to ≤32	>32 to ≤40	>40	
(1)	(2)	(3)	(4)	(5)	(6)	(7)	(8)	(9)	(10)	(11)	(12)
i)	Bending strength (MoR), MPa, Min.	20.0	18.0	17.0	16.0	15.0	13.0	12.0	10.0	8.0	IS 2380 (Part 4)
ii)	Modulus of Elasticity (MoE), MPa, Min.	2300	2200	2100	2000	1900	1700	1600	1600	1400	IS 2380 (Part 4)
iii)	Internal bond strength, MPa, Min.	0.50	0.50	0.45	0.45	0.40	0.35	0.30	0.25	0.25	IS 2380 (Part 5)
iv)	24h thickness swelling, percent, Max.	18	16	14	12	12	10	10	9	8	IS 2380 (Part 17)
v)	Screw withdrawal Face, N, Min.	1250									IS 2380 (Part 14)
vi)	Screw withdrawal Edge, N, Min.	--				850					IS 2380 (Part 14)
vii)	Moisture Resistance:										
	Option1, cyclic test: Internal bond Strength, MPa, Min.	0.25	0.24	0.23	0.22	0.18	0.16	0.14	0.12	0.10	IS 2380 (Part 5) See Note
	Thickness swell, percent, percent, Max.	16	14	13	12	11	10	9	8	7	IS 2380 (Part 17)
	Option 2, boil test: Internal bond strength, MPa, Min.	0.24	0.23	0.22	0.22	0.20	0.17	0.15	0.14	0.12	IS 2380 (Part 5) See Note

9.12 FN HMR Grade particleboard shall conform to the requirements given in Table 13.

TABLE 13 REQUIREMENTS FOR FN HMR PARTICLEBOARD
(Clause 9.12)

SI No.	Properties	Requirement Thickness ranges mm, nominal									Method of Test, Ref to
		≤3	>3 to ≤4	>4 to ≤6	>6 to ≤13	>13 to ≤20	>20 to ≤25	>25 to ≤32	>32 to ≤40	>40	
(1)	(2)	(3)	(4)	(5)	(6)	(7)	(8)	(9)	(10)	(11)	(12)
i)	Bending strength (MoR), MPa, Min.	21,0	20,0	19,0	18,0	16,0	15,0	14,0	12,0	10,0	IS 2380 (Part 4)
ii)	Modulus of Elasticity (MoE), MPa, Min.	2600	2600	2600	2600	2400	2100	1900	1700	1500	IS 2380 (Part 4)
iii)	Internal bond strength, MPa, Min.	0.55	0.55	0.50	0.50	0.45	0.40	0.35	0.30	0.25	IS 2380 (Part 5)
iv)	24h thickness swelling, percent, Max.	16	14	13	12	10	10	10	9	8	IS 2380 (Part 17)
v)	Screw withdrawal Face, N, Min.	1250									IS 2380 (Part 14)
vi)	Screw withdrawal Edge, N, Min.	--				850					IS 2380 (Part 14)
vii)	Moisture Resistance:										
	Option1, cyclic test: Internal bond Strength, MPa, Min.	0.40	0.40	0.35	0.30	0.25	0.25	0.20	0.18	0.15	IS 2380 (Part 5) See Note
	Thickness swell, percent, percent, Max.	12	11	10	10	9	9	8	7	6	IS 2380 (Part 17)
	Option 2, boil test: Internal bond strength, MPa, Min.	0.30	0.28	0.28	0.28	0.20	0.17	0.15	0.13	0.12	IS 2380 (Part 5) See Note

9.13 LB HMR Grade particleboard shall conform to the requirements given in Table 14.

TABLE 14 REQUIREMENTS FOR LB HMR PARTICLEBOARD
(Clause 9.13)

SI No.	Properties	Requirement Thickness ranges mm, nominal						Method of Test, Ref to
		>6 to ≤13	>13 to ≤20	>20 to ≤25	>25 to ≤32	>32 to ≤40	>40	
(1)	(2)	(3)	(4)	(5)	(6)	(7)	(8)	(9)
i)	Bending strength (MoR), MPa, Min.	22.0	20.0	18.0	17.0	16.0	14.0	IS 2380 (Part 4)
ii)	Modulus of Elasticity (MoE), MPa, Min.	3 350	3 100	2 900	2 800	2 600	2 400	IS 2380 (Part 4)
iii)	Internal bond strength, MPa, Min.	0.75	0.70	0.65	0.60	0.50	0.45	IS 2380 (Part 5)
iv)	24h thickness swelling, percent, Max.	9	8	8	8	7	7	IS 2380 (Part 17)
v)	Screw withdrawal Face, N, Min.	1250						IS 2380 (Part 14)
vi)	Screw withdrawal Edge, N, Min.	--	850					IS 2380 (Part 14)
vii)	Moisture Resistance:							
	Option1, cyclic test: Internal bond Strength, MPa, Min.	0.45	0.42	0.39	0.36	0.33	0.30	IS 2380 (Part 5) See Note
	Thickness swell, percent, percent, Max.	10	9	9	8	7	6	IS 2380 (Part 17)
	Option 2, boil test: Internal bond strength, MPa, Min.	0.37	0.35	0.32	0.30	0.27	0.25	IS 2380 (Part 5) See Note

NOTES – For Table 8 to 14, procedure for cyclic test and boil test shall be as follows:

1) Cyclic test – Specimens are immersed in water at (27 ± 2) °C for a period of 72 h, followed by drying in air at (27 ± 2) °C for 24 h and then heating in dry air at (70 ± 2) °C for 72 h. Three such cycles shall be followed and then the specimens are tested for internal bond strength.

2) Boil test (Accelerated water resistance test) – Specimens are immersed in water at (27 ± 2) °C and water is brought to boiling and kept at boiling temperature for 2 h. After (120 ± 5) min remove the test pieces and immerse them in water at (27 ± 2) °C for (60 ± 5) min. The test pieces shall have their faces

vertical and be separated from each other and from the sides and the bottom of the water bath by at least 15 mm. Remove the test pieces from the water, dry them with a paper towel and place them, with their faces horizontal, in the drying oven at (70 ± 2) °C for (960 ± 15) min. Remove the test pieces from the oven, allow them to cool to approximately room temperature and bond the loading blocks to the faces (If the surfaces of the test pieces are rough or uneven, they may be smoothed before bonding to the blocks by rubbing on a piece of abrasive paper which is held on a flat surface) and then tested for internal bond strength.

9.14 Formaldehyde Requirements

The particleboards shall conform to the requirements formaldehyde content and steady-state formaldehyde emission given in Table 15.

TABLE 15 REQUIREMENTS FOR FORMALDEHYDE CONTENT AND STEADY-STATE FORMALDEHYDE EMISSION
(Clause 9.14)

SI No.	Properties	Requirements	Method of Test, Ref to
(1)	(2)	(3)	(4)
i)	Formaldehyde content F_c , mg/100 g for oven dry board	For Formaldehyde Class, $E1$: $F_c \leq 8$	IS 13745
		For Formaldehyde Class, $E2$: 8 $< F_c \leq 30$	
ii)	Steady-state formaldehyde emission, F_c , mg/m ³ (<i>optional test</i>)	For Formaldehyde Class, $E1$: $F_c \leq 0.124$;	IS/ISO 12460 (Part 1)
		For Formaldehyde Class, $E2$: $F_c > 0.124$	

9.15 Additional tests for Prelaminated particleboard

The prelaminated particleboards shall conform to the requirements given Table 16.

TABLE 16 REQUIREMENTS OF PRELMAINATED PARTICLEBOARD SURFACE CHARACTERISTICS
(Clause 9.15)

SI No.	Properties	Requirements	Method of Test, Ref to,	
(1)	(2)	(3)	(4)	
i)	Abrasion resistance in number of revolutions, Min,		Annex C	
		Type 1		1000
		Type 2		450
		Type 3		250
		Type 4		75

ii)	Resistance to steam/water vapours	No blister, delamination or change in surface finish	Annex D
iii)	Resistance to crack	No sign of crack or delamination	Annex E
iv)	Resistance to a cigarette burn	No mark or stain on the specimen after cleaning with water or solvent	Annex F
v)	Resistance to stain	No stain on the specimen after cleaning with solvent or detergent	Annex G

9.16 Additional Tests for Veneered Particleboard

9.5.1 Adhesion of Plies – Three test specimens of 200 mm x 100 mm shall be taken for test. The adhesion of the face veneers to the particleboard core and the cross-bands and other veneers, where these exist, shall be such that when tested by forceful opening with a knife, these shall show appreciable resistance and the exposed surface of veneer shall show signs of some adherent fibres distributed more or less uniformly. The knife test is an empirical test and is only indicative and it should, therefore, be carried out with utmost care.

10 SAMPLING AND CRITERIA FOR CRITERIA FOR CONFORMITY

10.1 Sampling

10.1.1 Lot

In any consignment, all the particleboards of same classification, surface type (in case of prelaminated or veneered particleboard) and formaldehyde class, dimensions, and manufactured under similar conditions of production shall be grouped together to constitute a lot.

10.1.2 The conformity of a lot, to the requirements of this standard, shall be ascertained on the basis of tests on particleboards selected from it.

10.1.3 These particleboards shall be selected at random (see **IS 4905** for reference).

10.2 Criteria for Conformity

10.2.1 All the particleboards selected in accordance with **10.1.3** shall be measured for length, width, thickness, edge straightness, and squareness tests. These dimensions shall comply with the requirements specified in **8.1** and **8.2**, before proceeding with further testing.

10.2.2 If all the boards in **10.2.1** are found to be conforming, then from each of the particleboards, the test specimens shall be cut out from portions 150 mm away from the edges for the tests as mentioned in 9.

10.2.3 A lot shall be considered as conforming to the requirements of this standard, if all the samples and test specimens pass the conditions as prescribed in 8 and 9.

10.2.4 If any sample fails to conform the requirements, further samples shall be taken from

the lot, double in number, and the lot shall be considered to have passed, if these samples conform to the requirements prescribed.

11 ADDITIONAL REQUIREMENTS FOR ECO-MARK

11.1 General Requirement

11.1.1 Particleboard shall conform to the requirement specified in this standard.

11.1.2 The manufacturer shall produce to BIS, the environmental consent clearance from State Pollution Control Board as per the provisions of the Water (Prevention and Control of Pollution) Act, 1974 and Air (Prevention and Control of Pollution) Act, 1981, Water (Prevention and Control of Pollution) Act, 1981 and Water (Prevention and Control or Pollution) Cess Act, 1977 along with the authorization, if required under the Environment (Protection) Act, 1986, while applying for ECO-Mark appropriate with enforced rules and regulations of Forest Department.

11.2 Specific Requirement

Particleboards shall conform to the specific requirements given for ECO-Mark under relevant clauses of this standard.

12 MARKING

12.1 Each Particleboard shall be legibly marked with the following particulars either by direct printing or by an adhesive label.

- a) Name of the manufacturer or trademark,
- b) Particleboard/Prelaminated particleboard/Veneered particleboard
- b) Classification (*See clause 4*)
- c) Formaldehyde class
- d) Size and Thickness
- e) Batch number and
- f) Date of manufacturing
- g) The criteria for which the prelaminate particleboard has been labelled as ECO-Mark (in case the board has been marked with ECO-Mark) (see Foreword).

12.2 BIS Certification Marking

The particleboards may also be marked with the Standard Mark.

The product(s) may be marked with Standard Mark as per the conformity assessment schemes governed by the provisions of the Bureau of Indian Standards Act, 2016 and the Rules and Regulations made there under. The details of the conditions for the license may be obtained from the Bureau of Indian Standards.

ANNEX A
(Clause 2)**LIST OF REFERRED INDIAN STANDARDS**

IS No.	Title
IS 303: 2024	Plywood for General Purposes - Specification (<i>fourth revision</i>)
IS 707: 2011	Timber technology and utilization of wood, bamboo and cane — Glossary of terms (<i>third revision</i>)
IS 848: 2006	Synthetic resin adhesives for plywood (Phenolic And Aminoplastic) - Specification (<i>second revision</i>)
IS 2380	Methods of test for wood particleboards and boards from other lingo-cellulosic materials (<i>first revision</i>):
(Part 1): 1977	Preparation and conditioning of test specimens (<i>first revision</i>)
(Part 2): 1977	Accuracy of dimensions of boards (<i>first revision</i>)
(Part 3): 1977	Determination of moisture content and density (<i>first revision</i>)
(Part 4): 1977	Determination of static bending strength (modulus of rupture and modulus of elasticity in bending) (<i>first revision</i>)
(Part 5): 1977	Determination of tensile strength perpendicular to surface (<i>first revision</i>)
(Part 14): 1977	Screw and nail withdrawal test (<i>first revision</i>)
(Part 17): 1977	Determination of swelling in water (<i>first revision</i>)
IS 4905: 2015	Random sampling and randomization procedures (<i>first revision</i>)
IS 13745: 2020	Method for determination of formaldehyde content in woodbased panels by extraction method called perforator method (<i>first revision</i>)
IS 3400 (Part 2): 2023/ISO 48-2: 2018	Methods of test for rubber, vulcanized or thermoplastic Part 2 determination of hardness Section 2 hardness between 10 IRHD and 100 IRHD (<i>fifth revision</i>)
IS/ISO 12460 (Part 1): 2007	Wood-based panels — Determination of formaldehyde release: Part 1 Formaldehyde emission by the 1-cubic meter chamber method

ANNEX B (Clause 8.2)

METHOD OF TEST FOR EDGE STRAIGHTNESS AND SQUARENESS

B-1 PROCEDURE FOR EDGE STRAIGHTNESS

The straightness of the edges and ends of particleboard shall be verified against a straight edge not less than the full length of the board. If the edge on the end of the particleboard is convex, it shall be held against the straightness edge in such a way as to give approximately equal gap at each end, the largest gap between the straight edge and the edge shall be measured to the nearest millimetre and recorded.

B-2 PROCEDURE FOR SQUARENESS

The squareness of particleboard shall be checked with a 1 200 mm × 1 200 mm square, by applying one arm of the square to the square to the board. The maximum width of the gap shall be recorded.

ANNEX C (Clause 9.15)

METHOD or TEST FOR DETERMINING SURFACE ABRASION RESISTANCE

C-1 The test measures the ability of the decorative surface of the sheet under test to resist abrasive wear-through to the sub layer. Abrasion is achieved by rotating a specimen in contact with a pair of loaded cylindrical wheels covered with abrasive paper. The wheels are positioned so that their cylindrical faces are equidistant from the specimen's axis of rotation but not tangential to it. As they are turned by the rotating specimen, they abrade an annular track on the specimen's surface. The number of revolutions of the specimen required to cause a defined degree of abrasion is used as a measure of resistance to surface wear.

C-2 MATERIALS

C-2.1 Calibration Plates of Rolled Zinc Sheet

Calibration plates of rolled zinc plate shall have a thickness of 0.8 ± 0.1 mm and a Brinell hardness of 48 ± 2 BHN when tested in accordance with IS 1500 except that the ball diameter shall be 5 mm and the load 360 N.

C-2.2 Abrasive Paper Stripe

Abrasive paper strips shall be of 12.7 mm width and about 160 mm length having the following composition:

- a) Paper of grammage 70 g/m² to 100 g/m²:
- b) Powdered aluminium oxide having a particle size that it will pass through a sieve of aperture 100 µm and remain on a sieve having an aperture of 63 µm; and

c) Adhesive backing (optional).

C-2.3 Double-Sided Adhesive Tape

Double-sided adhesive tape shall be required only if the abrasive paper has no adhesive backing.

C-3 APPARATUS

C-3.1 Testing Machine

The testing machine shall be consisting of the items given in **C-3.1.1** to **C-3.1.5** (see Fig. 1).

C-3.1.1 Specimen Holder

The specimen holder shall be in the form of a disc (7) which rotates in a horizontal plane at a frequency of 58 rev/min to 62 rev/min and to which the test specimen (6) can be clamped flat (4/5).

C-3.1.2 Abrasive Wheel (3)

Abrasive wheels shall be two cylindrical rubber covered wheels of 12.7 mm width and 50 mm diameter which rotate freely about a common axis. The curved surface of the wheels to a depth of 6 mm, shall be of rubber (2) of hardness 50 to 55 TRHD when tested according to IS 3400 (Part 2). The inside faces of the wheels shall be 50 mm to 55 mm apart, and their common axis shall be 20 mm from the vertical axis of the specimen holder. The wheels shall be positioned symmetrically in a plane containing the axis of the specimen holder.

C-3.1.3 Holding and Lifting Device (8)

Holding and lifting device for the abrasive wheels, shall be so constructed that each wheel exerts a force of 5.4 ± 0.2 N on the test specimen.

C-3.1.4 Revolution Counter

C-3.1.5 Suction Device

Suction device shall be so fitted that two nozzles are over the abraded section of the specimen under test. One nozzle shall be situated between the wheels, the other diametrically opposite. The centres of the nozzles shall be 77 mm apart and 1 mm to 2 mm from the surface of the test specimen. When the nozzles are closed there shall be a vacuum of 1.5×10^{-3} N/mm² to 1.6×10^{-3} N/mm².

C-3.2 Conditioning Chamber

The conditioning chamber shall be capable of maintaining a standard atmosphere of 27 ± 20 °C and relative humidity of 65 ± 5 percent.

C-4 TEST SPECIMENS

Each test specimen shall be a piece of the sheet under test, shaped to fit the type of clamping device used. It will usually be a disc of diameter about 130 mm, or a square of about 120 mm with its corners rounded to give a diagonal of about 130 mm and it will usually have a hole of diameter 6 mm in its centre. Three specimens shall be prepared.

C-5 PREPARATION OF TEST SPECIMENS AND ABRASIVE PAPER

Clean the surface of the test specimens with an organic solvent which is immiscible with water, for example, trichloroethane. Precondition the test specimens and the abrasive strips for at least 72 h in the conditioning atmosphere (see **B-3.2**) before testing.

C-6 PROCEDURE

C-6.1 Preparation of Abrasive Wheels

Bond a strip of preconditioned abrasive paper (see **C-2.2**) to each of the rubber-covered wheels using either the adhesive backing, if present, or the double sided adhesive tape (see **C-2.3**), in such a way that the cylindrical surface is completely covered but without any overlapping of the abrasive paper (see Fig. 1).

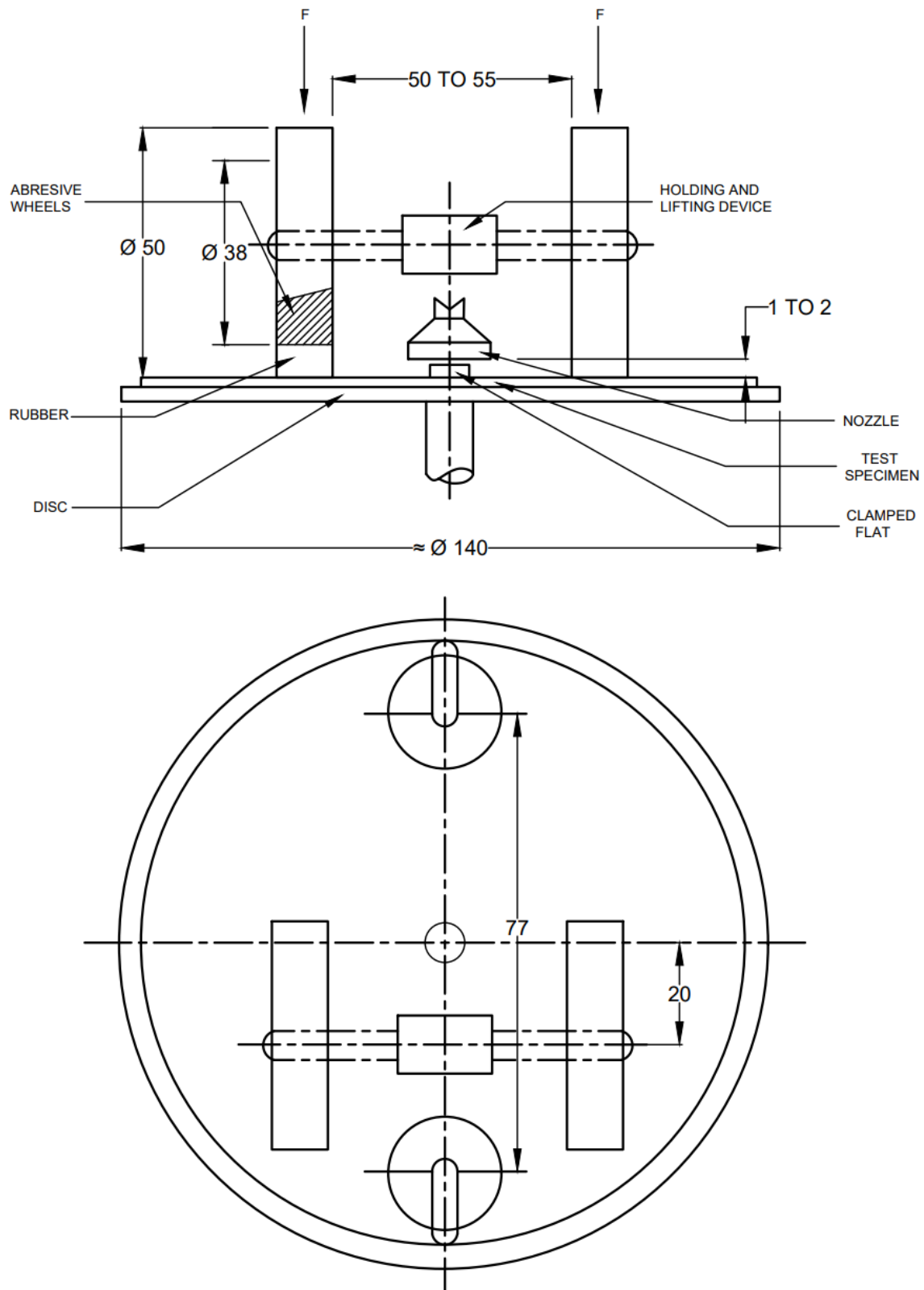

All dimensions in millimetres.

FIG. 1 TYPE OF APPARATUS FOR MEASURING ABRASION RESISTANCE.

ANNEX D
(Clause 9.15)

METHOD OF DETERMINING SURFACE RESISTANCE TO STEAM

D-1 GENERAL

This test determines the surface resistance of prelaminated medium density particle against contact with steam atmospheric pressure.

D-2 NUMBER OF TEST PIECES

Three specimens shall be used for each test.

D-3 SPECIMEN SIZE

Specimen of size 100 mm x 100 mm in full thickness shall be used.

D-4 PREPARATION OF SAMPLE

The test specimen shall be cut to the required size from the sample board, 150 mm away from the corner of the edge. The specimens selected shall have compact edges with no loose core particles.

D-5 APPARATUS

This test requires very simple apparatus.

D-5.1 Electric hot plate of size 200 mm diameter or 200 mm x 200 mm minimum

D-5.2 Glass Conical Flask, 250 ml.

D-5.3 A Holding Clamp

D-6 PREPARATION OF APPARATUS

Place the conical flask filled with water up to 100 cc on the hot plate. Cover the mouth of the conical flask with the specimens such that the surface to be tested shall face downwards. Put the clamp to secure specimen from falling down.

D-7 PROCEDURE

D-7.1 Start heating the water in the flask by putting on the electric heater. After sometime water will start boiling. Note the time and continuously heat for a total period of one hour. Steam will come in contact with the board surface and escape into the atmosphere.

D-7.3 Observe the surface of the specimen closely and note down the remarks in the register.

ANNEX E
(Clause 9.15)

**METHOD OF TEST FOR DETERMINING RESISTANCE TO CRACKING OF
LAMINATION UNDER HEAT**

E-1 GENERAL

This test determines the surface resistance to cracking when the specimen is subjected to a temperature of 70-100 °C of a definite time.

E-1 NUMBER OF TEST PIECES

Three specimens shall be used for each test,

E-2 SPECIMEN SIZE

Specimen of size 100 mm x 100 mm in full thickness of the board.

E-3 PREPARATION OF SAMPLE

The test specimen shall be cut in the required size from the sample board 150 mm away from the corner of the edge. The specimens selected shall have compact edge with no loose core particles.

E-4 APPARATUS

Electric oven of suitable size having temperature range of 50-150 °C.

E-5 PROCEDURE

Keep the temperature stabilized at 70 ± 2 °C. Keep the specimens in the oven. Remove the specimens after 24 hours duration and observe of cracks on the lamination surface.

Then maintain a temperature of 100 ± 20 °C and keep the fresh specimens. Remove them after 2 hours and observe for surface cracks and blemishes.

ANNEX F
(Clause 9.15)

METHOD OF TEST FOR DETERMINING RESISTANCE TO CIGARETTE BURN

F-1 GENERAL

This test is to check the effect of leaving a glowing cigarette on the lamination surface.

F-2 NUMBER OF SAMPLES

Three specimens shall be taken for the test.

F-3 SPECIMEN SIZE

Specimen of size 200 mm x 100 mm in full thickness of the board.

F-4 PROCEDURE

Place a glowing cigarette horizontally on the specimen. Keep it for 60 s and remove it from the specimen as soon as 60 s are lapsed. This could be checked by a stopwatch. Clean the area with water or a suitable solvent and observe if any blister has formed or the surface colour lot changed.

ANNEX G

(Clause 9.15)

METHOD OF TEST FOR DETERMINING RESISTANCE TO STAIN

G-1 GENERAL

This test determines effect of staining materials on the lamination surface.

G-2 OUTLINE OF THE METHOD

Different staining materials are applied to separate test specimens of the decorative laminates, covered suitably and allowed to remain in contact for a specified period. The staining agent is washed off, cleaned with a domestic abrasive cleaner and the surface examined for the staining produced.

G-3 APPARATUS

Glass covers, one for each staining material to prevent evaporation.

NOTE – Watch glasses are suitable for this purpose.

G-4 STAINING MATERIALS

Coffee and acetic acid solution (10 percent concentration) are the staining materials to be used on the prelaminated medium density particleboard.

G-5 TEST SPECIMENS

G-5.1 Specimens to be cut from the sheet to be tested shall be 75 mm long and 25 mm wide.

G-5.2 The number of specimens for sheet shall be equal to twice the number of staining materials selected for test.

G-6 PROCEDURE

Apply each staining material to two test specimens at room temperature. Cover one of the two test specimens with a glass cover and allow them to stand for 24 hours. Wash each specimen with water containing a suitable wetting agent and then with denatured spirit (see IS 324). Allow the specimens to dry. After one hour place the specimens in horizontal position under overhead white fluorescent light having an intensity of 800 to 1 100 lumens/m². Exclude light from other sources. View the specimens at an angle of approximately 9a' to the specimens where the staining agent is specifically applied. If any staining or discoloration is noticed attempt to remove it by gently rubbing with a mild domestic abrasive cleaner. Allow the specimens to dry and examine them again under conditions mentioned above.

G-7 EVALUATION

The material shall be deemed to have passed the test if no specimen shows blistering, staining or discoloration when finally examined. Specimen on which stains are removable by light rubbing with soap and water, or a mild abrasive domestic cleaner shall be considered acceptable.