

**भारतीय मानक ब्यूरो**

(उपभोक्ता मामले, खाद्य एवं सार्वजनिक वितरण मंत्रालय, भारत सरकार)

BUREAU OF INDIAN STANDARDS

(Ministry of Consumer Affairs, Food & Public Distribution, Govt. of India)

मानक भवन, 9, बहादुर शाह ज़फर मार्ग, नई दिल्ली - 110002
Manak Bhawan, 9, Bahadur Shah Zafar Marg, New Delhi - 110002

Phones: 23230131 / 2323375 / 23239402

Website: www.bis.org.in , www.bis.gov.in**प्रारंभिक मसौदा****हमारा संदर्भ : सीईडी 30/टी-6****03 अक्टूबर 2024****तकनीकी समिति : निर्माण अनुभागीय समिति के लिए मिट्टी और स्थिर मिट्टी उत्पाद, सीईडी 30****प्राप्तकर्ता :**

- क) सिविल इंजीनियरी विभाग परिषद्, सीईडीसी के सभी सदस्य
ख) सीईडी 30 के सभी सदस्य
ग) रूचि रखने वाले अन्य निकाय

प्रिय महोदय/महोदया,

निम्नलिखित भारतीय मानक का मसौदा संलग्न है:

प्रलेख संख्या	शीर्षक
सीईडी 30 (26671)P	हेवी ड्यूटी जली हुई मिट्टी से बनी ईंटें - विशिष्टता (IS 2180 का चौथी संशोधन) ICS No. 91.100.25

कृपया इस मसौदे की जाँच करें और इसमें और सुधार के संबंध में अपनी सम्मतियाँ साझा करें।

सम्मतियाँ भेजने की अंतिम तिथि: 24/10/2024टिप्पणियाँ, यदि कोई हों, बीआईएस ई-गवर्नेंस पोर्टल https://www.services.bis.gov.in/php/BIS_2.0/WCDraft/comment_pdraft.php के माध्यम से ऑनलाइन भेजी जा सकती हैं।वैकल्पिक रूप से, टिप्पणियाँ संलग्न प्रारूप में भी दर्ज की जा सकती हैं और ced30@bis.gov.in या divya.s@bis.gov.in पर ईमेल की जा सकती हैं।**आपको अपनी टिप्पणियाँ सबमिट करने के लिए लॉग इन करने की आवश्यकता हो सकती है, कृपया लॉग इन करने के लिए अपने मोबाइल नंबर (बीआईएस को प्रदान किया गया) और ओटीपी प्रावधान का उपयोग करें।**

यदि कोई सम्मति प्राप्त नहीं होती है अथवा सम्मति में केवल भाषा संबंधी त्रुटि हुई तो हम मान लेंगे कि प्रारंभिक मसौदे के लिए आपका अनुमोदन प्राप्त हुआ है। यदि सम्मति तकनीकी प्रकृति की हुई तो उसे विषय समिति के अध्यक्ष के परामर्श से आवश्यक कार्रवाई के लिए विषय समिति के सामने रखा जाएगा।

धन्यवाद।

भवदीय

ह/-

(दिव्या एस.)

सदस्य सचिव सीईडी 30

वैज्ञानिक 'डी'(सिविल इंजीनियरिंग)

ई-मेल: divya.s@bis.gov.in

संलग्न: उपरलिखित

**भारतीय मानक ब्यूरो**

(उपभोक्ता मामले, खाद्य एवं सार्वजनिक वितरण मंत्रालय, भारत सरकार)

BUREAU OF INDIAN STANDARDS

(Ministry of Consumer Affairs, Food & Public Distribution, Govt. of India)

मानक भवन, 9, बहादुर शाह ज़फर मार्ग, नई दिल्ली - 110002
Manak Bhawan, 9, Bahadur Shah Zafar Marg, New Delhi -
110002

Phones: 23230131 / 2323375 / 23239402

Website: www.bis.org.in , www.bis.gov.in**PRELIMINARY DRAFT****Our Reference: CED 30/T- 6****03 October 2024****Technical Committee: Clay and Stabilized Soil Products for Construction
Sectional Committee, CED 30****Addressed To:**

- All Members of Civil Engineering Division Council, CEDC
- All Members of CED 30
- All others interested

Dear Sir/Madam,

Please find enclosed the following document:

<i>Doc No.</i>	<i>Title</i>
CED 30 (26671)P	Heavy Duty Burnt Clay Building Bricks — Specification [Fourth Revision of IS 2180] ICS No. 91.100.25

Kindly examine the attached draft and forward your comments for further improvement.

Last Date for comments: 24 October 2024Comments if any, may be sent online through the BIS e-governance portal at https://www.services.bis.gov.in/php/BIS_2.0/WCDraft/comment_pdraft.php.Alternatively, comments may also be recorded in the enclosed format and emailed at ced30@bis.gov.in or at divya.s@bis.gov.in.***You may be required to login to submit your comments, kindly use your mobile number (provided to BIS) and the otp provision to login.***

In case no comments are received, or comments received are of editorial nature, kindly permit us to presume your approval for the above document. However, in case comments of technical nature are received, then in consultation with the Chairperson, CED 30 the comments may be put up to the Sectional Committee for necessary action.

Thanking you,

Sd/-

(Divya S.)

Member Secretary CED 30

Scientist 'D' (Civil Engineering)

E-mail: divya.s@bis.gov.in**Encl: As above**

FORMAT FOR SENDING COMMENTS ON THE DOCUMENT

[Please use A4 size sheet of paper only and type within fields indicated. Comments on each clause/sub-clause/ table/figure, etc, be stated on a fresh row. Information/comments should include reasons for comments, technical references and suggestions for modified wordings of the clause. **Comments through https://www.services.bis.gov.in/php/BIS_2.0/WCDraft/comment_pdraft.php shall be appreciated.**]

Doc. No.: CED 30(26671)P**BIS Letter Ref:** CED 30/T-6

Title: Heavy Duty Burnt Clay Building Bricks — Specification
[*Fourth Revision* of IS 2180]

Last date of comments: **24 October 2024****Name of the Commentator/ Organization:** _____

Sl No.	Clause/ Para/ Table/ Figure No. commented	Comments/ Modified Wordings	Justification of Proposed Change
1.			
2.			
3.			
4.			
5.			
6.			
7.			
8.			
9.			
10.			
11.			
12.			
13.			

NOTE- Kindly insert more rows as necessary for each clause/table, etc

BUREAU OF INDIAN STANDARDS

Preliminary Draft Indian Standard

HEAVY DUTY BURNT CLAY BUILDING BRICKS — SPECIFICATION
(Fourth Revision of IS 2180)

FOREWORD

(Formal clause will be added later.)

This standard was first published in 1962 and subsequently revised in 1970, 1985 and in 1988. In the third revision, the class designation of the bricks was modified to be based on the minimum compressive strength of the bricks expressed in N/mm² instead of kgf/cm². Furthermore, sub-classifications A and B of bricks have been completely removed deleting requirements of sub-class B bricks and the tolerances on dimensions of bricks have been changed.

Heavy-duty bricks (also known as 'engineering bricks') are generally required for masonry in heavy engineering works, such as bridge structures, industrial foundations and flooring/paving. In view of the establishment of various mechanized plants, it is felt that some guidelines for the quality requirements of such bricks should be laid down, so that bricks of such strength could be judiciously utilized.

Significant modifications in this revision are:

- a) The requirements of bricks to be free from flaws and nodules of free lime have been removed.
- b) It has been highlighted that bricks of 40 mm height are not recommended for structural use.
- c) The maximum individual variation of compressive strength from the mean value has been reduced to 15 percent.
- d) The concept of shape factor for 40mm high bricks have been introduced.
- e) The minimum bulk density of the bricks † has been modified to 2200 kg/cm³.
- f) The requirements for warpage have been revised.
- g) The provision to eliminate frogs in bricks of 40 mm made by extrusion process has been included.

This standard contributes to the following United Nations Sustainable Development Goal 11 'Sustainable cities and communities' towards strengthen efforts to protect and safeguard the world's cultural and natural heritage and Goal 12 'Ensure sustainable consumption and production patterns' towards substantially reduce waste generation through prevention, reduction, recycling and reuse.

For the purpose of deciding whether a particular requirement of this standard is complied with, the final value, observed or calculated, expressing the result of a test or analysis, shall be rounded off in accordance with IS 2 : 2022 'Rules for rounding off numerical values (second revision)'. The number of significant places retained in the rounded off value should be the same as that of the specified value in this standard.

Preliminary Draft Indian Standard

HEAVY DUTY BURNT CLAY BUILDING BRICKS — SPECIFICATION

(Fourth Revision IS 2180)

1 SCOPE

This standard lays down requirements for classification, general quality, dimensions and physical properties of heavy-duty burnt clay building bricks.

2 REFERENCES

The standards given below contain provisions which through reference in this text, constitute provisions of this standard. At the time of publication, the editions indicated were valid. All standards are subject to revision and parties to agreements based on this standard are encouraged to investigate the possibility of applying the most recent edition of these standards:

<i>IS No.</i>	<i>Title</i>
IS 2248 : XXXX	Glossary of terms relating to clay products for buildings (<i>Second Revision under development</i>)
IS 3495 (Part 1) : 2019	Burnt Clay Building Bricks Methods of Tests Part 1 Determination of Compressive Strength (<i>Fourth Revision</i>)
(Part 2) : 2019	Part 2 Determination of Water Absorption (<i>Fourth Revision</i>)
(Part 3) : 2019	Part 3 Determination of Efflorescence (<i>Fourth Revision</i>)
(Part 4) : 2019	Part 4 Determination of Warpage (<i>Fourth Revision</i>)
IS 5454 : 2024	Burnt Clay Bricks and Burnt Clay Tiles — Methods of Sampling (<i>second revision</i>).
IS 1077 : XXXX	Common Burnt Clay Building Bricks – Specification (<i>Fifth Revision under development</i>)

3 TERMINOLOGY

For the purpose of this standard, definitions given in IS 2248 shall apply.

4 CLASSIFICATION

The heavy duty bricks shall be classified on the basis of average compressive strength as given below:

<i>Class Designation</i>	<i>Average Compressive Strength</i>	
	Not less than, N/mm ²	Less than, N/mm ²
40	40.0	45

45 45.0 -

5 GENERAL QUALITY

5.1 Heavy duty burnt clay bricks shall be manufactured either by pressing or extrusion. They shall be made from processed clay or clays blended in right proportions. The brick shall be burnt to the correct maturing temperature of the clay or clay blend, properly soaked, and cooled under controlled conditions. When broken, the fractured surface of the brick shall show a uniformly dense structure free from large voids, laminations and lime particles. Two bricks, when struck together, shall emit a clear metallic ring.

5.2 The bricks shall have smooth rectangular faces with sharp corners and shall be uniform in colour.

6 DIMENSIONS AND TOLERANCES

6.1 Dimensions - The standard size of heavy duty clay building bricks shall be as follows:

Length (<i>L</i>) <i>mm</i>	Width (<i>W</i>) <i>mm</i>	Height (<i>H</i>) <i>mm</i>
190	90	90
190	90	40

NOTE — Bricks of height 40mm are not recommended for load bearing purposes, and if used, their suitability for the same may be ascertained.

6.2 The maximum permissible tolerances on the dimensions specified in **6.1** shall be as follows:

<i>Dimensions</i> <i>mm</i>	Tolerance of Individual Bricks <i>mm</i>
190	± 4
90	± 2
40	± 2

7 PHYSICAL REQUIREMENTS

7.1 Compressive Strength

The bricks when tested in accordance with the procedure laid down in IS 3495 (Part 1), shall have a minimum average compressive strength for various classes as given in 4.

NOTE — In any case of the results for compressive strength exceed the upper limit of the class, the same shall be limited to upper limit of the class for the purpose of averaging.

7.1.1 The compressive strength of 40 mm high bricks may be multiplied by a shape factor of 0.72 and the corrected strength shall be as per the requirements in 4.

7.1.2 The compressive strength of any individual brick shall not fall below the minimum average compressive strength specified for the corresponding class of brick by more than 15 percent.

7.2 Water Absorption

The bricks when tested according to the procedure laid down in 4.1 of IS 3495 (Part 2) after immersion in water for 24 hours, the average water absorption by mass shall not be more than 10 percent.

7.2.1 If specified by the purchaser, 5 hours boiling test according to the procedure laid down in 4.2 of IS 3495 (Part 2) may also be done. In that case, the average water absorption by mass shall not be more than 15 percent.

7.3 Efflorescence

The bricks when tested in accordance with the procedure laid down in IS 3495 (Part 3), the rating of efflorescence shall be 'Nil'.

7.4 Bulk Density

The density of bricks shall not be less than 2200 kg/m³. Result shall be reported correct to 10 kg/m³.

7.4.1 For obtaining the bulk density, the brick shall be dried in a ventilated oven at a temperature of 105 to 115°C until it attains constant mass; that is two consecutive dry weights after two hours of further drying do not differ by 0.1 percent. The brick shall be cooled to room temperature and its mass shall be obtained. The dimensions of the brick shall be measured accurate to 1 mm and the overall volume computed. The bulk density shall then be calculated as mass per unit volume.

7.5 Warpage

The bricks when tested in accordance with the procedure laid down in IS 3495 (Part 4), the average warpage shall not be more than 3 mm or 5 percent of the height of the brick, whichever is lower.

8 SAMPLING AND CRITERION FOR CONFORMITY

The method of sampling and the criterion for conformity shall be in accordance with the procedure laid down in IS 5454.

9 MARKING

9.1 Each brick shall be marked (in the frog where provided) with the manufacturers identification mark or initials. Bricks of 40 mm height made by extrusion process may not be provided with frogs.

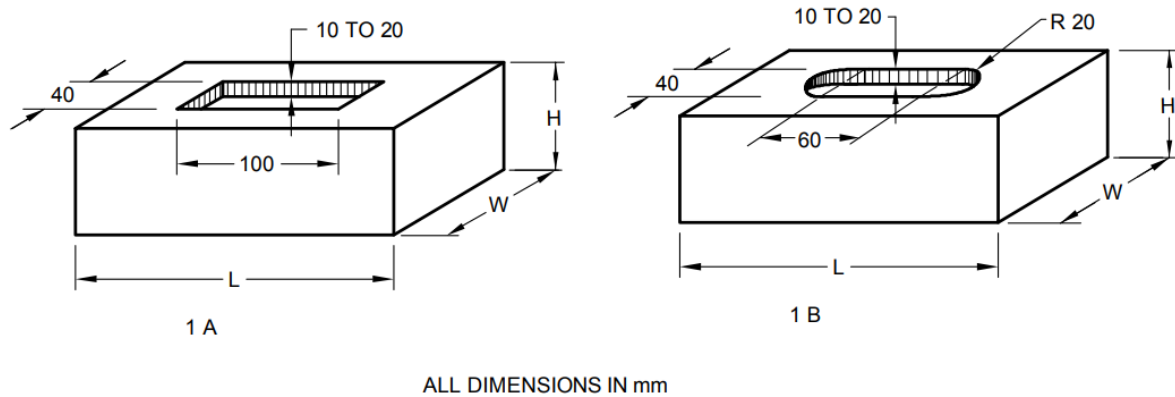

FIG.1 SHAPE AND SIZE OF FROGS IN BRICKS

9.1.1 BIS certification marking

The product(s) may be marked with Standard Mark as per the conformity assessment schemes governed by the provisions of the Bureau of Indian Standards Act, 2016 and the Rules and Regulations made there under. The details of conditions for the licence may be obtained from the Bureau of Indian Standards.