

---

---

लघु जलयान — मुख्य डेटा  
(पहला पुनरीक्षण)

Small Craft — Principal Data  
(First Revision)

ICS 47.080

© BIS 2024  
© ISO 2020



भारतीय मानक ब्यूरो  
BUREAU OF INDIAN STANDARDS  
मानक भवन, 9 बहादुर शाह ज़फर मार्ग, नई दिल्ली - 110002  
MANAK BHAVAN, 9 BAHADUR SHAH ZAFAR MARG  
NEW DELHI - 110002  
[www.bis.gov.in](http://www.bis.gov.in) [www.standardsbis.in](http://www.standardsbis.in)

## NATIONAL FOREWORD

This Indian Standard (First Revision) which is identical to ISO 8666 : 2020 'Small craft — Principal data' issued by the International Organization for Standardization (ISO), was adopted by the Bureau of Indian Standards on recommendation of the Inland Harbour Crafts and Fishing Vessels Sectional Committee and approval of the Transport Engineering Divisional Council.

This standard was first published in 2020 which was identical adoption of ISO 8666 : 2016. This revision has been undertaken to harmonize it with ISO 8666 : 2020. The changes compared to the previous edition are as follows:

- a) Addition of [2](#), Normative references, and the renumbering of the remaining clauses; all cross-references have been accordingly updated;
- b) The 'allowance for the maximum mass of optional equipment and fittings not included in the manufacturer's basic outfit' has been moved from 6.6 (maximum load, former 5.6) to 7.8 (maximum load condition, former 6.8).
- c) Hindi title of the standard has been modified.

The text of ISO standard has been approved as suitable for publication as an Indian Standard without deviations. Certain conventions and terminologies are, however, not identical to those used in Indian Standards. Attention is particularly drawn to the following:

- a) Wherever the words 'International Standard' appear referring to this standard, they should be read as 'Indian Standard'; and
- b) Comma (,) has been used as a decimal marker, while in Indian Standards, the current practice is to use a point (.) as the decimal marker.

Attention is drawn to the possibility that some of the elements of this document may be the subject of patent rights. The Bureau of Indian Standard shall not be held responsible for identifying any or all such patent rights.

For the purpose of deciding whether a particular requirement of this standard is complied with the final value, observed or calculated, expressing the result of a test or analysis shall be rounded off in accordance with IS 2 : 2022 'Rules for rounding off numerical values (*second revision*)'. The number of significant places retained in the rounded off value should be the same as that of the specified value in this standard.

# Contents

Page

<b>1</b>	<b>Scope</b> .....	<b>1</b>
<b>2</b>	<b>Normative references</b> .....	<b>1</b>
<b>3</b>	<b>Terms and definitions</b> .....	<b>1</b>
<b>4</b>	<b>Symbols, designations and units</b> .....	<b>3</b>
<b>5</b>	<b>Measurements</b> .....	<b>4</b>
5.1	General.....	4
5.2	Longitudinal.....	4
5.2.1	General.....	4
5.2.2	Maximum length, $L_{\max}$ .....	4
5.2.3	Length of the hull, $L_H$ .....	4
5.2.4	Waterline length, $L_{WL}$ .....	7
5.3	Athwartship.....	8
5.3.1	General.....	8
5.3.2	Maximum beam, $B_{\max}$ .....	8
5.3.3	Beam of hull, $B_H$ .....	8
5.3.4	Beam, waterline, $B_{WL}$ .....	8
5.3.5	Maximum beam, waterline, $B_{WL\max}$ .....	8
5.3.6	Beam between hull centres, $B_{CB}$ .....	8
5.4	Vertical.....	9
5.4.1	Maximum depth, $D_{\max}$ .....	9
5.4.2	Midship depth, $D_{LWL/2}$ .....	9
5.4.3	Freeboard, $F$ .....	10
5.4.4	Draught, $T$ .....	10
5.4.5	Draught, air, $H_a$ .....	10
5.4.6	Headroom.....	11
5.5	Other data.....	11
5.5.1	Deadrise angle, $\beta$ .....	11
5.5.2	Reference sail area, $A_S$ .....	12
5.5.3	Standard sail area, $A'_S$ .....	12
5.5.4	Windage area, $A_{IV}$ .....	12
5.5.5	Volume of the craft, $V$ .....	12
<b>6</b>	<b>Masses</b> .....	<b>13</b>
6.1	Mass, net shipping, $m_N$ .....	13
6.2	Mass, gross shipping, $m_G$ .....	13
6.3	Mass, light craft, $m_{LC}$ .....	14
6.3.1	Items of equipment included in $m_{LC}$ .....	14
6.3.2	Items of equipment and other items not included in $m_{LC}$ .....	15
6.4	Performance test mass, $m_P$ .....	15
6.5	Mass of the craft when towed on a trailer, $m_T$ .....	16
6.5.1	General.....	16
6.5.2	Items of equipment included in $m_T$ .....	16
6.5.3	Items of equipment not included in $m_T$ .....	18
6.5.4	Exclusions, inclusions.....	18
6.6	Maximum load, $m_{ML}$ .....	18
<b>7</b>	<b>Loading conditions</b> .....	<b>19</b>
7.1	Test condition.....	19
7.2	Ready-for-use condition.....	19
7.3	Fully loaded ready-for-use condition.....	19
7.4	Empty craft condition.....	19
7.5	Light craft condition.....	20
7.6	Minimum operating condition.....	21

7.7	Loaded arrival condition .....	21
7.8	Maximum load condition .....	21
<b>8</b>	<b>Tolerances .....</b>	<b>21</b>
8.1	Published data .....	21
8.2	Preliminary specification .....	22
8.3	Reference lengths .....	22
	<b>Bibliography .....</b>	<b>23</b>

*Indian Standard*  
**SMALL CRAFT — PRINCIPAL DATA**  
( *First Revision* )

## 1 Scope

This document establishes definitions of main dimensions and related data and of mass specifications and loading conditions. It applies to small craft having a length of the hull ( $L_H$ ) of up to 24 m.

## 2 Normative references

There are no normative references in this document.

## 3 Terms and definitions

For the purposes of this document, the following terms and definitions apply.

NOTE For units, see [Clause 4](#).

ISO and IEC maintain terminological databases for use in standardization at the following addresses:

- ISO Online browsing platform: available at <https://www.iso.org/obp>
- IEC Electropedia: available at <http://www.electropedia.org/>

### 3.1

#### **waterline**

WL

intersection line of the water's surface with the craft's hull when the *craft* ([3.15](#)) is afloat

### 3.2

#### **maximum load waterline**

#### **reference waterline**

$WL_{ref}$

*waterline* ([3.1](#)) of the *craft* ([3.15](#)) when upright in the maximum *loaded displacement* ([3.6](#))

### 3.3

#### **sheerline**

intersection between deck and hull, for rounded deck edges the natural intersection, or, where no deck is fitted or the hull extends above the deck (bulwark), the upper edge of the craft's hull

Note 1 to entry: The upper position of the sheerline depends on the inclination between the hull/deck intersection and the actual deck.

### 3.4

#### **transom beam**

$B_T$

maximum width of the hull at the transom at or below the *sheerline* ([3.3](#)), excluding extensions, handles and fittings

Note 1 to entry: Where spray rails act as chines or part of the planing surface, they are included in the transom beam measurement.

Note 2 to entry: For *craft* ([3.15](#)) with a rounded or pointed stern or with a transom beam of less than half the maximum beam of the craft, the transom beam,  $B_T$ , is the widest beam at or below the sheerline at the aft quarter length of the hull.

### 3.5 displacement

mass of water displaced by the *craft* (3.15), including all appendages

### 3.6 loaded displacement

$m_{LDC}$

mass of water displaced by the *craft* (3.15), including all appendages, when in the fully loaded ready-for-use condition

Note 1 to entry: Fully loaded ready-for use condition is described in 7.3.

### 3.7 displacement volume

$V_D$

volume of water displaced by the *craft* (3.15) that corresponds to the *displacement* (3.5)

Note 1 to entry: Where the density of water used to calculate the volume of displacement is not salt water at a density of 1 025 kg/m<sup>3</sup>, the density of water used to calculate the volume of displacement is specified.

### 3.8 tank capacity

net usable volume of the tank(s) for the *craft* (3.15) in *design trim* (3.13) at rest at the *maximum load waterline* (3.2)

### 3.9 wing mast

spar characterized by its cross-section which shows a smooth transition at the aft end into the sail, thus, contributing to its driving force

### 3.10 non-sailing boat

*craft* (3.15) for which the primary means of propulsion is other than by wind power, having *reference sail area* (3.12)  $(A_S) < 0,07 (m_{LDC})^{2/3}$

### 3.11 sailing boat

*craft* (3.15) for which the primary means of propulsion is by wind power, having *reference sail area* (3.12)  $(A_S) \geq 0,07 (m_{LDC})^{2/3}$

### 3.12 reference sail area

$A_S$   
actual profile area of sails set abaft a mast, plus the maximum profile areas of all masts, plus reference triangle area(s) forward of each mast

### 3.13 design trim

longitudinal attitude of the *craft* (3.15) when upright, with crew, fluids, stores, and equipment in the position(s) and load condition(s) designated by the designer or builder

### 3.14 underway

not at anchor, or made fast to the shore, or aground

### 3.15 craft small craft

recreational boat, and other watercraft using similar equipment, of up to 24 m length of hull ( $L_H$ )

## 4 Symbols, designations and units

Unless specifically otherwise defined, the symbols, designations and units used in this document are given in [Table 1](#).

**Table 1 — Symbols, designations and units**

Symbol	Designation	Unit	Clause
$A_{IV}$	Windage area	m <sup>2</sup>	<a href="#">5.5.4</a>
$A_S$	Reference sail area	m <sup>2</sup>	<a href="#">5.5.2</a>
$A'_S$	Standard sail area	m <sup>2</sup>	<a href="#">5.5.3</a>
$B_{CB}$	Beam between hull centres	m	<a href="#">5.3.6</a>
$B_H$	Beam of hull	m	<a href="#">5.3.3</a>
$B_{max}$	Maximum beam	m	<a href="#">5.3.2</a>
$B_{WL}$	Beam, waterline	m	<a href="#">5.3.4</a>
$B_{WLmax}$	Maximum beam, waterline	m	<a href="#">5.3.5</a>
$B_T$	Transom beam	m	<a href="#">3.4</a>
$D_{max}$	Maximum depth	m	<a href="#">5.4.1</a>
$D_{LWL/2}$	Midship depth	m	<a href="#">5.4.2</a>
$F$	Freeboard	m	<a href="#">5.4.3</a>
$F_A$	Freeboard, aft	m	<a href="#">5.4.3.2</a>
$F_F$	Freeboard, forward	m	<a href="#">5.4.3.4</a>
$F_M$	Freeboard, amidships	m	<a href="#">5.4.3.3</a>
$H_a$	Draught, air	m	<a href="#">5.4.5</a>
$L_H$	Length of the hull	m	<a href="#">5.2.3</a>
$L_{max}$	Maximum length	m	<a href="#">5.2.2</a>
$L_{WL}$	Waterline length	m	<a href="#">5.2.4</a>
$m_G$	Gross shipping mass	kg	<a href="#">6.2</a>
$m_{LDC}$	Loaded displacement	kg	<a href="#">3.6</a>
$m_{LC}$	Light craft mass	kg	<a href="#">6.3</a>
$m_N$	Net shipping mass	kg	<a href="#">6.1</a>
$m_P$	Performance test mass	kg	<a href="#">6.4</a>
$m_T$	Mass of craft when towed on trailer	kg	<a href="#">6.5</a>
$m_{ML}$	Maximum load	kg	<a href="#">6.6</a>
$T$	Draught	m	<a href="#">5.4.4</a>
$T_C$	Draught, canoe body	m	<a href="#">5.4.4.4</a>
$T_{max}$	Draught, maximum	m	<a href="#">5.4.4.2</a>
$T_{min}$	Draught, minimum	m	<a href="#">5.4.4.3</a>
$V_D$	Displacement volume	m <sup>3</sup>	<a href="#">3.7</a>
$V$	Volume of the craft	m <sup>3</sup>	<a href="#">5.5.5</a>
$V_H$	Volume of the hull	m <sup>3</sup>	<a href="#">5.5.5.2</a>
$V_S$	Volume of the superstructure	m <sup>3</sup>	<a href="#">5.5.5.3</a>
WL	Waterline		<a href="#">3.1</a>
WL <sub>ref</sub>	Maximum load waterline		<a href="#">3.2</a>
$\beta$	Deadrise angle	degrees	<a href="#">5.5.1</a>

## 5 Measurements

### 5.1 General

Measurements shall be established with the craft at rest at the maximum load waterline/reference waterline,  $WL_{ref}$  unless otherwise stated.

### 5.2 Longitudinal

#### 5.2.1 General

The lengths of a craft shall be measured parallel to the maximum load waterline/reference waterline and craft centreline as the distance between two vertical planes, perpendicular to the centreplane of the craft.

#### 5.2.2 Maximum length, $L_{max}$

The maximum length ( $L_{max}$ ) shall be measured in accordance with [5.2.1](#), one plane tangent through the foremost part and the other through the aftermost part of the craft.

This length includes all structural and integral parts of the craft, such as stems or sterns, bulwarks, and hull/deck joints.

This length includes parts which are normally fixed, such as fixed spars, bowsprits, pulpits at either end of the craft, stemhead fittings, rudders, outboard motor brackets, outdrives, waterjets, and any propulsion units extending beyond the transom, diving and boarding platforms, rubbing strakes, and permanent fenders.

Outdrives, waterjets, other propulsion units, and all movable parts shall be measured in their normal operating condition to their maximum lengthwise extension when the craft is underway.

This length excludes the following:

- outboard motors;
- any other type of equipment that can be detached without the use of tools.

See [Figure 1](#) for monohull measurements and [Figure 2](#) for multihull measurements.

#### 5.2.3 Length of the hull, $L_H$

The length of the hull ( $L_H$ ) shall be measured in accordance with [5.2.1](#), one plane passing through the foremost part of the craft and the other through the aftermost part of the craft.

This length includes all structural and integral parts of the craft, such as stems or sterns, bulwarks, and hull/deck joints.

This length excludes removable parts that can be detached in a non-destructive manner and without affecting the structural integrity of the craft, e.g. spars, bowsprits, pulpits at either end of the craft, stemhead fittings, rudders, outdrives, outboard motors and their mounting brackets and plates, diving platforms, boarding platforms, rubbing strakes, and fenders if they do not act as hydrostatic support when the watercraft is at rest or underway.

With multihull craft, the length of each hull shall be measured individually. The length of the hull,  $L_H$ , shall be taken as the longest of the individual measurements.

See [Figure 1](#) for monohull measurements and [Figure 2](#) for multihull measurements.



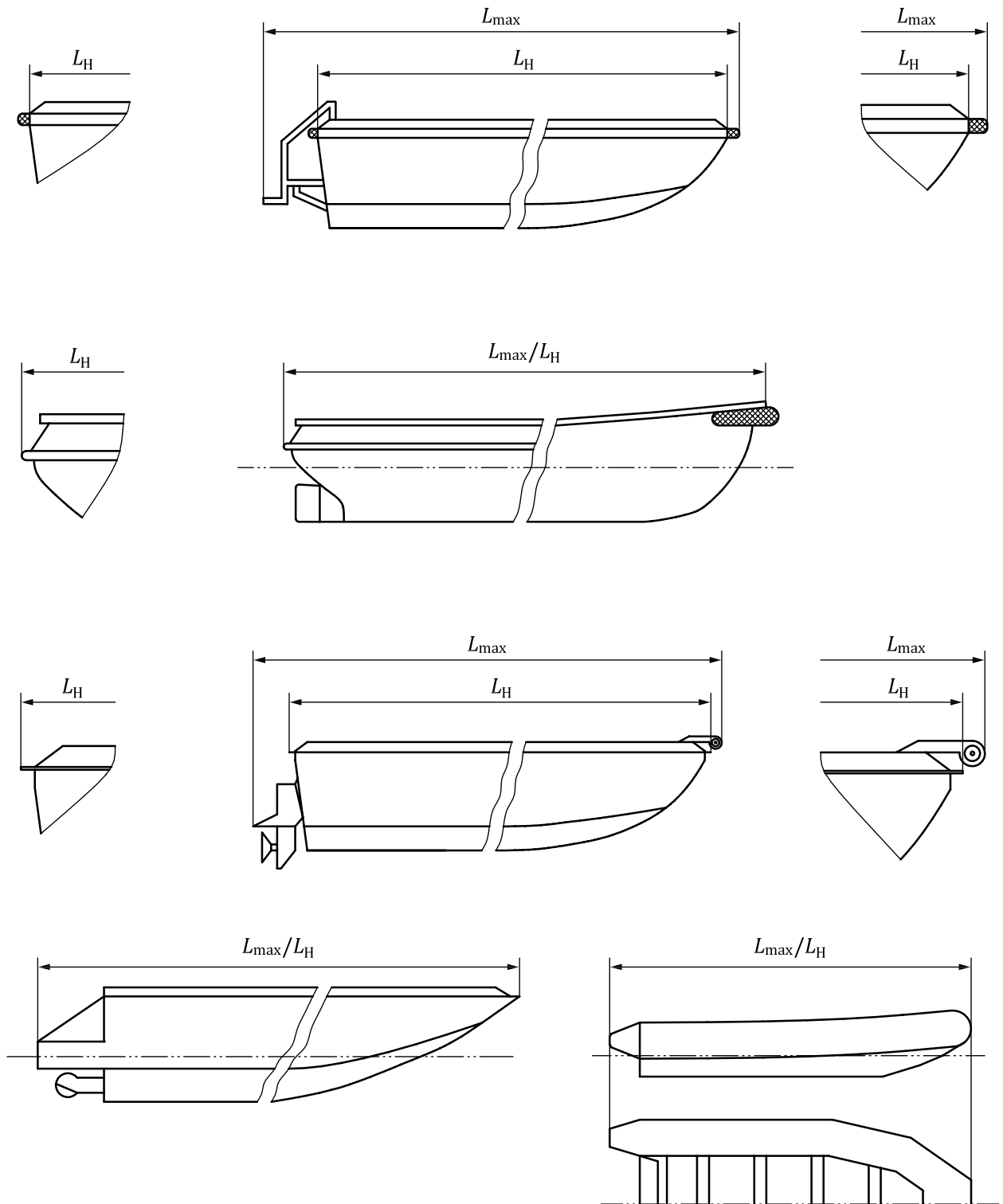

a) Determination of  $L_{max}$  and  $L_H$  for monohull non-sailing boats

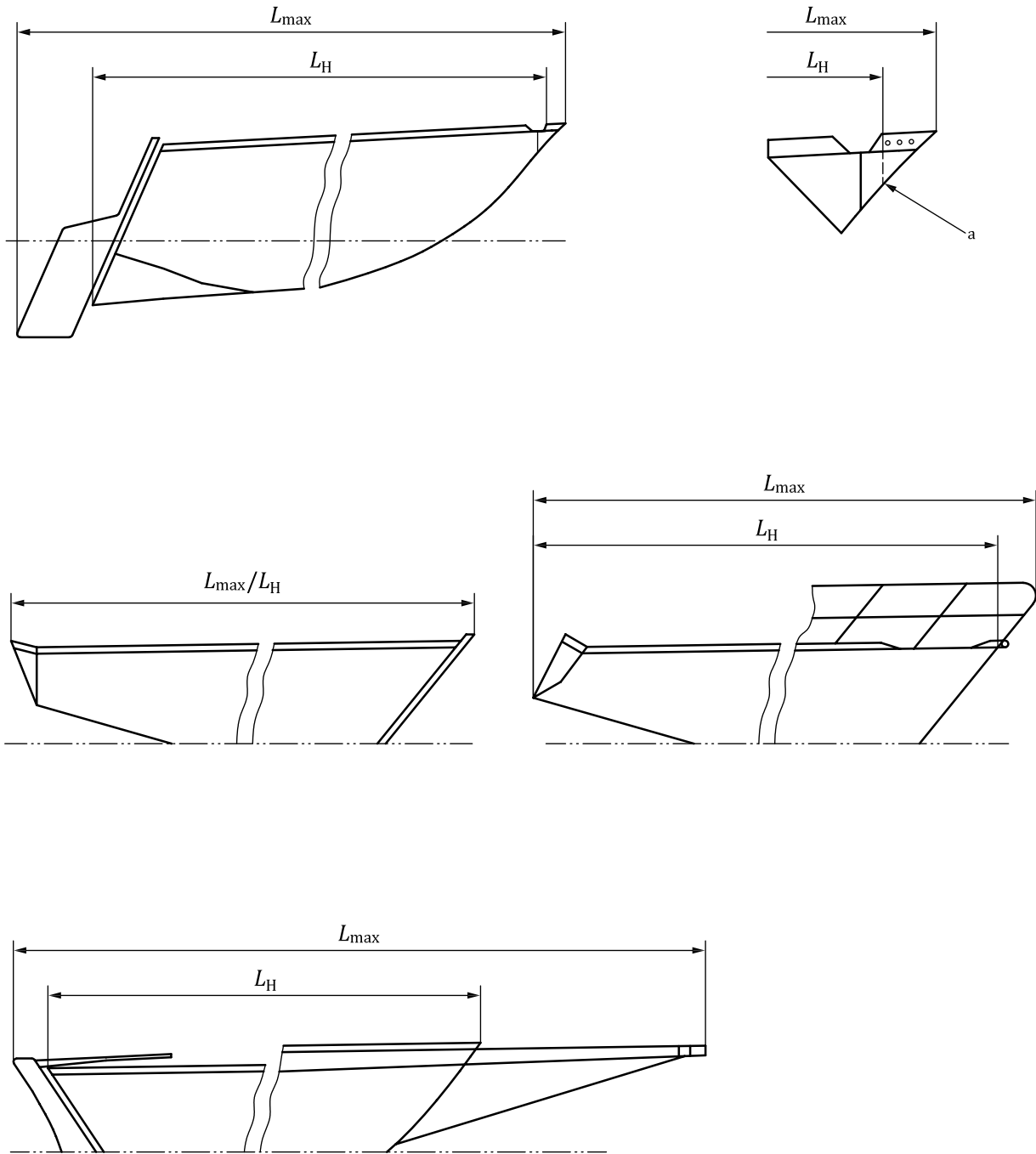

**b) Determination of  $L_{max}$  and  $L_H$  for monohull sailing boats**

a Hull ends here.

**Figure 1 — Determination of  $L_{max}$  and  $L_H$  for monohull craft**

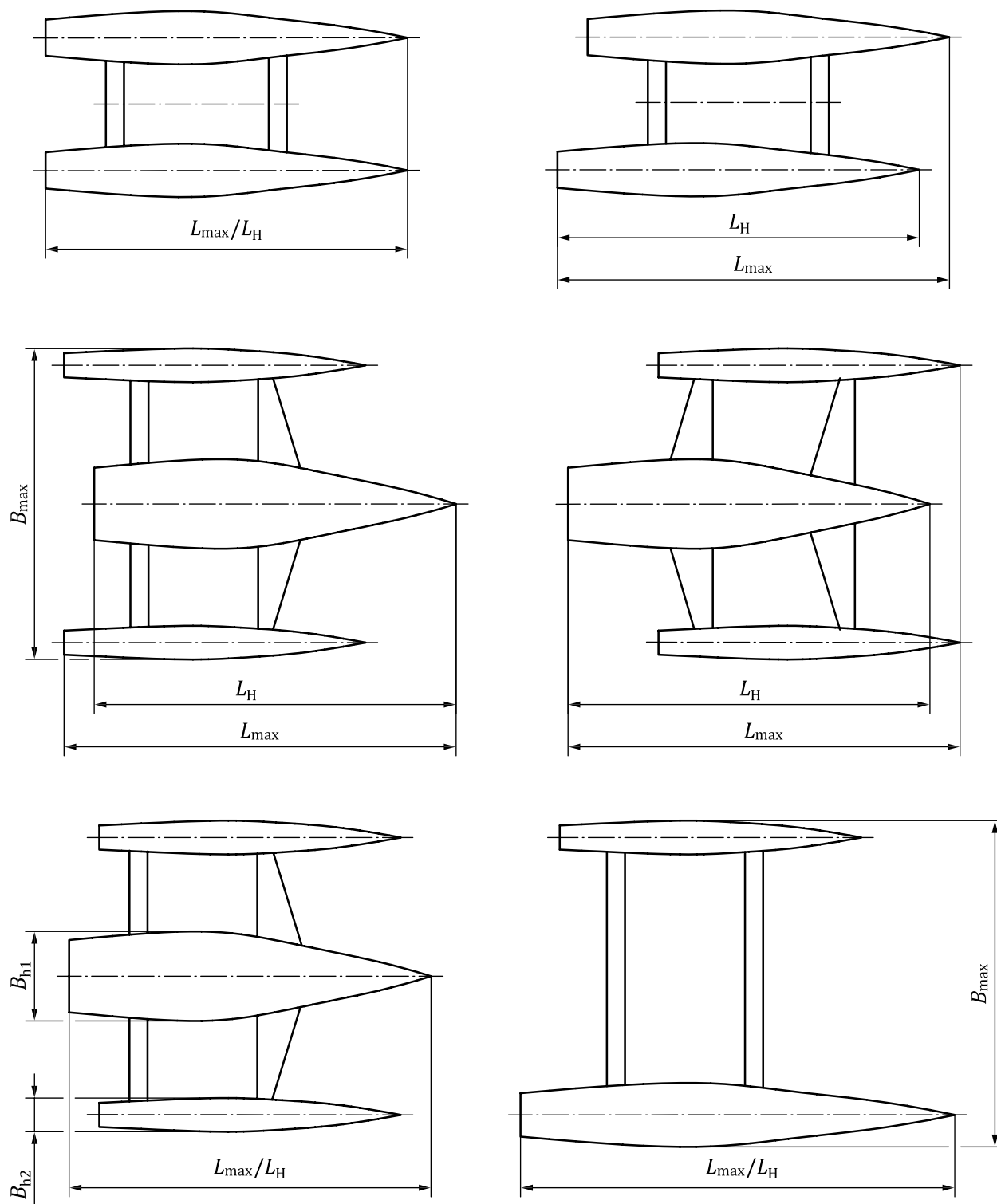

**Figure 2 — Determination of  $L_{max}$ ,  $L_H$ ,  $B_{max}$  and  $B_H$  for multihulls**

#### 5.2.4 Waterline length, $L_{WL}$

The waterline length ( $L_{WL}$ ) for a designated load condition and its corresponding design trim shall be measured in accordance with 5.2.1, one plane passing through the foremost intersection of the stem with the flotation plane and the other through the aftermost intersection of the hull and the flotation plane.

NOTE For multihull craft,  $L_{WL}$  relates to that of the longest individual hull.

## 5.3 Athwartship

### 5.3.1 General

Athwartship dimensions shall be measured as the distance between two vertical planes parallel to the centreplane of the craft when upright.

### 5.3.2 Maximum beam, $B_{\max}$

The maximum beam ( $B_{\max}$ ) shall be measured in accordance with [5.3.1](#) between planes tangent through the outermost parts of the craft.

The maximum beam includes all structural or integral parts of the craft, such as extensions of the hull, hull/deck joints, extensions such as doublings, sheer planks, chain plates, rubbing strakes, permanent fenders, and liferails extending beyond the craft's side.

For multihulls,  $B_{\max}$  shall be measured as the beam across the outer hulls.

### 5.3.3 Beam of hull, $B_H$

The beam of the hull ( $B_H$ ) shall be measured in accordance with [5.3.1](#) between the outermost permanently fixed parts of the hull.

The beam of the hull includes all structural or integral parts of the craft such as extensions of the hull, hull/deck joints, and bulwarks.

The beam of the hull excludes removable parts that can be detached in a non-destructive manner and without affecting the integrity of the craft, e.g. rubbing strakes, fenders, liferails and stanchions extending beyond the craft's side, and other similar equipment.

For multihulls,  $B_H$  shall be measured as the beam across the outer hulls.

See [Figure 1](#) for monohull measurements and [Figure 2](#) for multihull measurements.

### 5.3.4 Beam, waterline, $B_{WL}$

The beam at waterline ( $B_{WL}$ ) shall be measured in accordance with [5.3.1](#) as the maximum distance between the intersection of the hull surface and the flotation plane for a specific loading condition.

For multihulls, the beam at waterline shall be established for each hull individually.

### 5.3.5 Maximum beam, waterline, $B_{WL\max}$

For multihulls only, the maximum beam at waterline ( $B_{WL\max}$ ) shall be measured as the waterline beam across the outer hulls.

### 5.3.6 Beam between hull centres, $B_{CB}$

For catamaran and trimaran, the beam between hull centres ( $B_{CB}$ ) shall be measured as the transverse distance between the centres of buoyancy of the outer hulls.

## 5.4 Vertical

### 5.4.1 Maximum depth, $D_{\max}$

The maximum depth ( $D_{\max}$ ) shall be measured as the vertical distance between the sheerline at half-length of the waterline ( $L_{WL}$ ) and the lowest point of the keel.

NOTE With traditional long-keeled craft, the slope of the keel may result in increased draught aft which is not at half-length of the waterline or length of the hull.

### 5.4.2 Midship depth, $D_{LWL/2}$

The midship depth ( $D_{LWL/2}$ ) shall be measured at half-length of the waterline ( $L_{WL}$ ) as the distance between the sheerline and the lowest point of the keel at the same position.

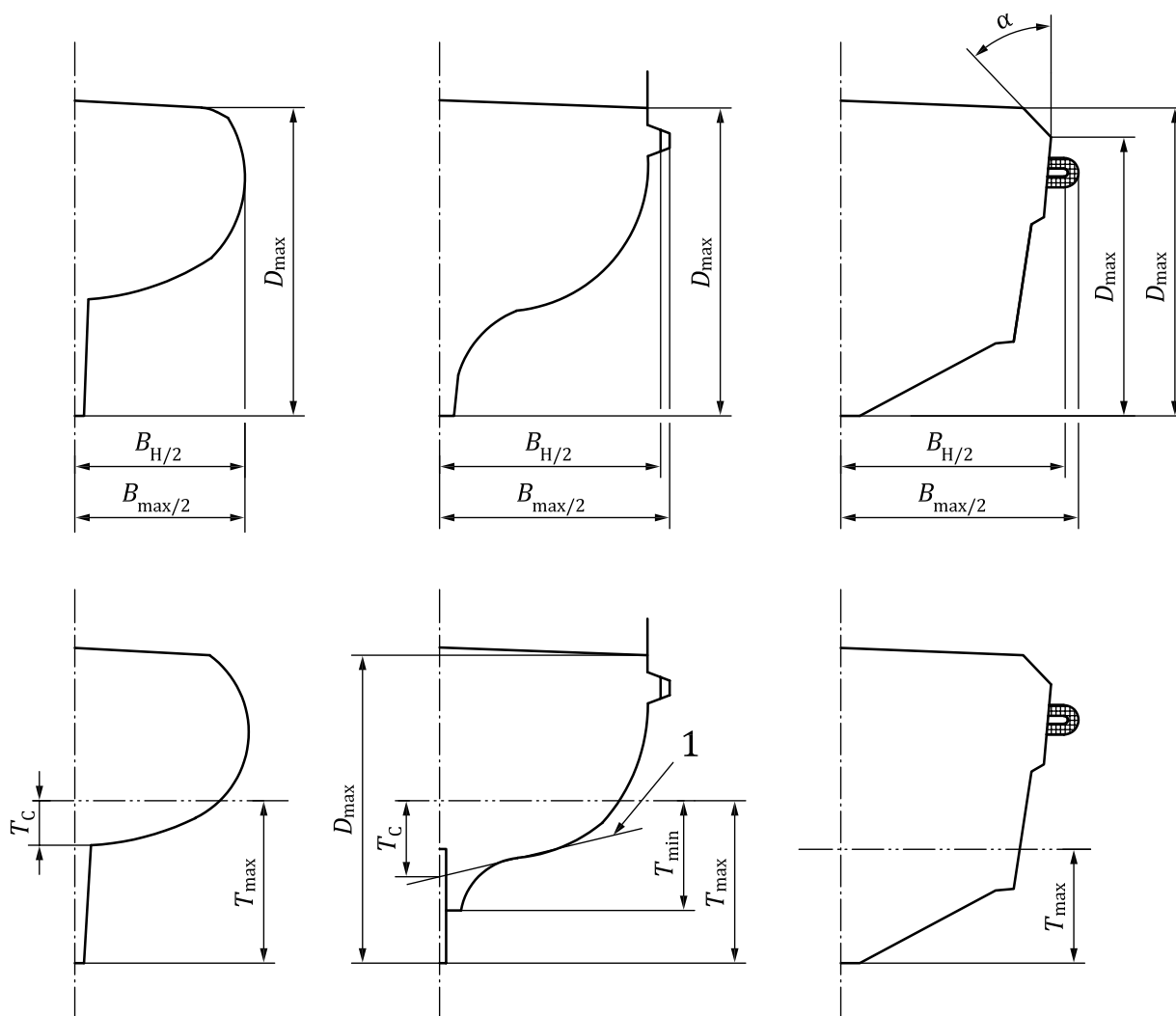

#### Key

1 tangent

NOTE The upper position of  $D_{\max}$  depends on the inclination between the hull/deck intersection and the actual deck. Where  $\alpha \geq 45^\circ$ , the lower position applies. Where  $\alpha < 45^\circ$ , the upper position applies.

Figure 3 — Determination of  $B_{\max}$ ,  $B_H$ ,  $D$  and  $T$

### 5.4.3 Freeboard, $F$

#### 5.4.3.1 General

The freeboard ( $F$ ) shall be measured as the vertical distance between the sheerline at the defined lengthwise location and the waterline in any specified loading condition.

#### 5.4.3.2 Freeboard, aft, $F_A$

The aft freeboard ( $F_A$ ) shall be measured in accordance with [5.4.3.1](#) at the aftermost point of the sheerline.

#### 5.4.3.3 Freeboard, amidships, $F_M$

The amidships freeboard ( $F_M$ ) shall be measured in accordance with [5.4.3.1](#) at half-length of the waterline,  $L_{WL}$ .

#### 5.4.3.4 Freeboard, forward, $F_F$

The forward freeboard ( $F_F$ ) shall be measured in accordance with [5.4.3.1](#) at the most forward point of the sheerline.

### 5.4.4 Draught, $T$

#### 5.4.4.1 General

The draught ( $T$ ) shall be measured as the vertical distance between the waterline in the fully loaded ready-for-use condition and a specific point of the underwater body (see [Figure 3](#)).

#### 5.4.4.2 Draught, maximum, $T_{max}$

The maximum draught ( $T_{max}$ ) shall be measured to the lowest point of the underwater body or appendage, including centreboards, in their lowest position.

#### 5.4.4.3 Draught, minimum, $T_{min}$

The minimum draught ( $T_{min}$ ) shall be measured to the lowest point of the craft or non-retractable appendage, whichever is lower. All movable underwater parts shall be in their uppermost possible position.

#### 5.4.4.4 Draught, canoe body, $T_C$

The canoe body draught ( $T_C$ ) shall be measured to the lowest point of the canoe body at the centreline of the craft. In cases where the keel form cannot be easily separated from that of the hull, the canoe body draught shall be determined by the intersection of the least steep tangent to the hull surface with the centreline plane.

NOTE Draft of canoe body excludes appendages such as rudders or skegs.

### 5.4.5 Draught, air, $H_a$

The air draught ( $H_a$ ) shall be measured as the vertical distance between the flotation plane in the light craft condition and the highest point of the craft's structure or mast.

## 5.4.6 Headroom

The headroom shall be measured as the vertical distance between the top of the cabin/compartment floor and the underside of the deck beam or deck head (whichever is lower) at a designated position. The manufacturer is free to state the headroom in other locations, e.g. above bunks.

## 5.5 Other data

### 5.5.1 Deadrise angle, $\beta$

The deadrise angle ( $\beta$ ) is the angle of the bottom from the horizontal measured athwartship, at a specific position, in degrees. The measurement shall be taken as indicated in [Figure 4](#).  $\beta$  is derived by [Formula \(1\)](#).

$$\text{ArcTan} \frac{\text{Height}(1)}{\text{Width}(2)} \quad (1)$$

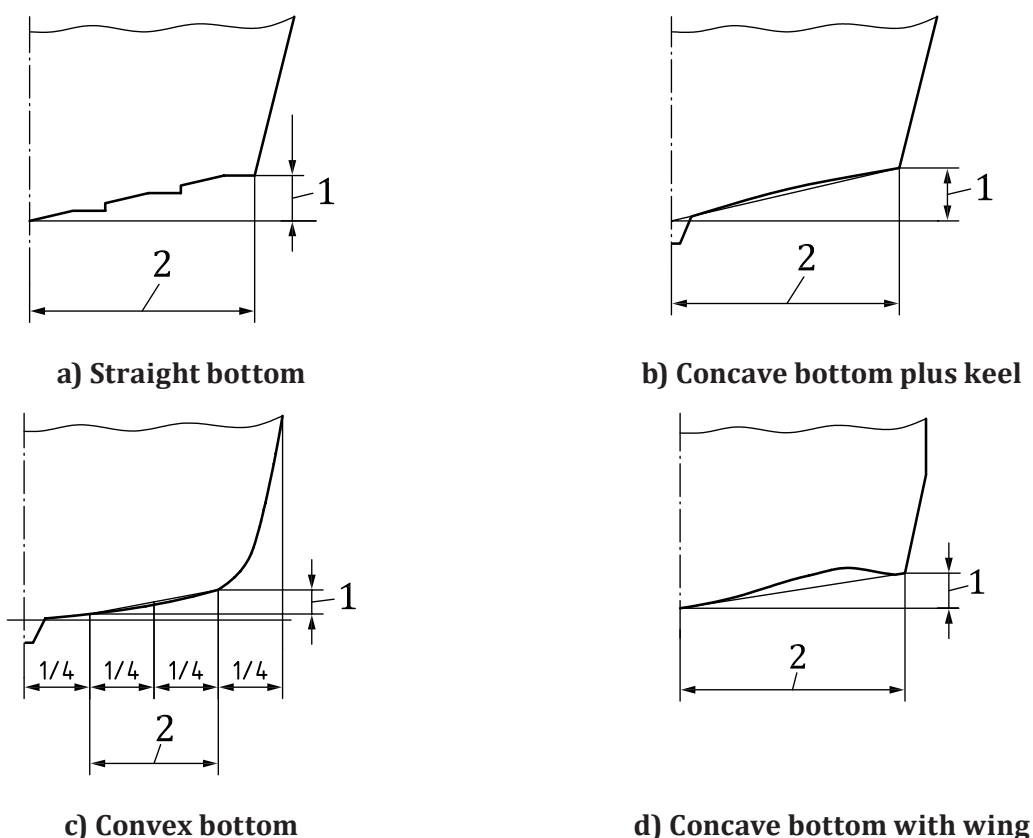

#### Key

1 height

2 width

NOTE 1 In [Figure 4](#) a), steps and other protrusions are ignored.

NOTE 2 In [Figure 4](#) b), deadrise is measured between keel intersection and chine.

NOTE 3 In [Figure 4](#) c), deadrise is measured between  $\frac{1}{4}$  and  $\frac{3}{4}$  of  $B_H/2$ .

NOTE 4 In [Figure 4](#) d), deadrise is measured between centreline and outer wing end.

Figure 4 — Determination of deadrise

### 5.5.2 Reference sail area, $A_S$

Actual profile area of all sails set abaft a mast, plus the maximum profile areas of all masts, plus the reference triangle area(s) forward of each mast given by  $IJ/2$  where  $I$  and  $J$  are measurements between the forward side of the mast, the aft side of the forestay, and the sheerline as shown in [Figure 5](#).

Where forestays between masts do not reach the deck, the area of the fore-triangle shall be taken as illustrated ( $I_2$  and  $J_2$ ), but only if sails are carried that may be set on the stays concerned.

### 5.5.3 Standard sail area, $A'_S$

Actual profile area of the largest sail plan suitable for windward sailing, including overlaps, and supplied or recommended by the builder as standard.

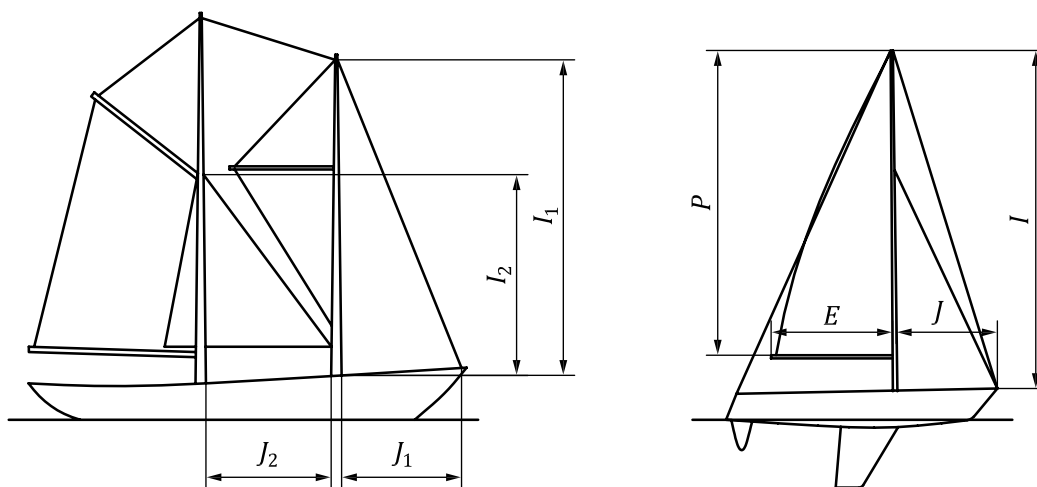

**Key**

- $I$  height of fore triangle
- $J$  base of fore triangle
- $P$  height of mainsail
- $E$  base of mainsail

**Figure 5 — Measurement of sail area**

### 5.5.4 Windage area, $A_{lv}$

Projected profile area of the hull, superstructures, deckhouses, outboard motors, and spars above the waterline at the appropriate loading condition, the craft being upright expressed in square metres.

### 5.5.5 Volume of the craft, $V$

#### 5.5.5.1 General

The volume ( $V$ ), in cubic metres, of a craft is given by [Formula \(2\)](#).

$$V = V_H + V_S \tag{2}$$

where

- $V_H$  is the volume of the hull, in cubic metres;
- $V_S$  is the volume of the superstructure, in cubic metres.



The volume of the craft shall be established either by accepted naval architectural methods or by an approximate assessment according to 5.5.5.2 and 5.5.5.3.

The volume shall be measured as follows (see Figure 6).

### 5.5.5.2 Volume of the hull, $V_H$

Using the approximate method, the volume of the hull shall be determined as follows (see Figure 6):

$$V_H = 0,15 L_H (B_0 D_0 + B_{20} D_{20} + B_{40} D_{40} + B_{60} D_{60} + B_{80} D_{80} + B_{100} D_{100}) \quad (3)$$

### 5.5.5.3 Volume of the superstructure, $V_S$

The volume of the superstructure ( $V_S$ ) shall be the sum of the volume for each part of the superstructure above the sheerline/deck at the side. Any space that is open at no more than one side shall be incorporated in the calculation. Open in this sense means that no more than 10 % of the area may be covered.

Volumes of less than 0,05 m<sup>3</sup> shall be omitted.

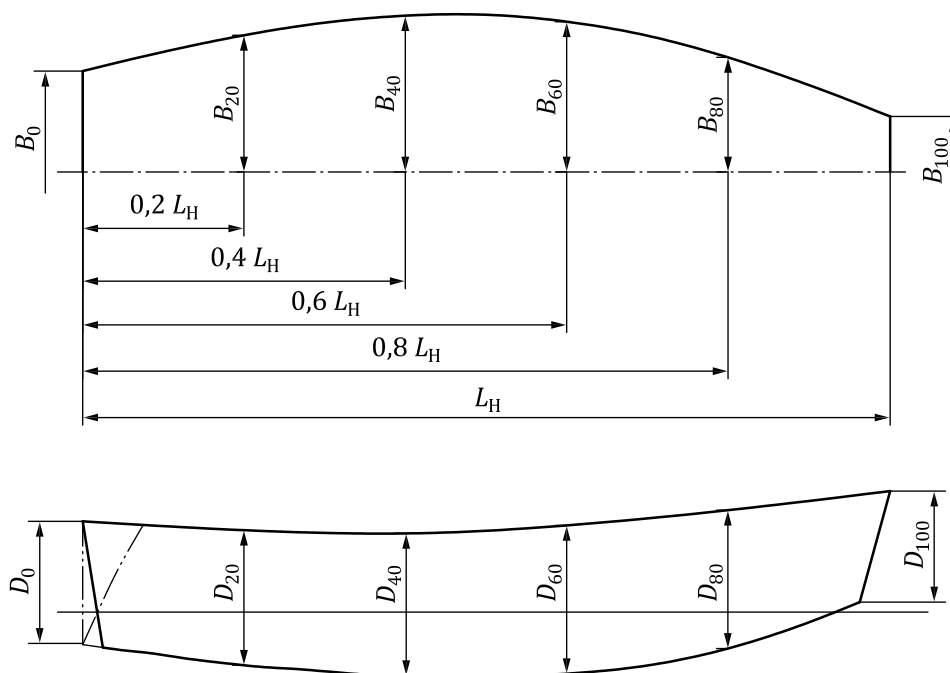

Figure 6 — Volume measurement

## 6 Masses

### 6.1 Mass, net shipping, $m_N$

The net shipping mass ( $m_N$ ) shall include all permanent and loose equipment delivered with the craft by the manufacturer, but no shipping materials.

### 6.2 Mass, gross shipping, $m_G$

The gross shipping mass ( $m_G$ ) is the net shipping mass, as defined above, plus shipping materials such as cradles, supports, fastening material, and covers.

### 6.3 Mass, light craft, $m_{LC}$

#### 6.3.1 Items of equipment included in $m_{LC}$

##### 6.3.1.1 General

The mass in the light craft condition ( $m_{LC}$ ) (unladen mass of the craft) shall include items of equipment as listed below.

##### 6.3.1.2 Structure

The structure comprises all the structural parts, including the ballast keel and/or centreboard/daggerboard(s) and rudder(s).

##### 6.3.1.3 Ballast

The ballast comprises the removable ballast (whether solid or liquid) intended by the manufacturer to be carried when the craft is underway.

##### 6.3.1.4 Internal structure and accommodation

The internal structure and accommodation are made up of bulkheads and partitions, insulation, lining, built-in furniture, flotation material, windows, hatches and doors, and upholstery material.

##### 6.3.1.5 Engine and fuel system

###### 6.3.1.5.1 Permanently installed engine and fuel systems

The permanently installed engine and fuel systems are comprised of inboard engine(s), including all supplies and controls as needed for their operation, and permanently installed fuel systems, including tanks.

###### 6.3.1.5.2 Outboard engines

The mass of the craft shall be stated with the mass of the outboard motor(s) as follows:

- mass of the heaviest engine(s), as recommended by the craft manufacturer, irrespective of the fact that the manufacturer may have fitted a lighter engine and related equipment;
- mass of any permanently installed fuel system;
- mass of engine controls and steering system.

###### 6.3.1.6 Internal equipment

The internal equipment includes the following:

- all items of equipment permanently attached to the craft, e.g. tanks, toilet system(s), water transfer equipment, bilge pumping system(s), cooking and heating devices, cooling equipment, ventilation system(s);
- electrical installation and equipment, including batteries;
- fixed navigational and electronic equipment;
- fire fighting equipment, where fitted;
- mattresses, curtains.

### 6.3.1.7 External equipment

For all craft, this includes the following:

- all permanently attached deck fittings, e.g. guardrails, pulpits and pushpits, bowsprits and their attachments, bathing platforms, boarding ladders, steering equipment, winches, sprayhood(s), awning(s), cockpit tables, gratings, signal mast(s), where fitted;
- anchor(s), anchor warps and chains;
- loose external equipment, e.g. fenders, warps, painters.

For craft with sailing rig(s), this includes the following:

- mast(s), boom(s), spinnaker poles and other pole(s), standing and running rigging, all upwind sails supplied or recommended by the builder, onboard and rigged ready for use, but not hoisted, e.g. mainsail on boom, roller furling sails furled, hanked foresails on stay stowed on foredeck.

### 6.3.2 Items of equipment and other items not included in $m_{LC}$

These items are the following:

- loose internal equipment, e.g. cutlery, crockery, kitchen utensils, linen;
- loose electronic and navigational equipment (e.g. charts);
- tools, spare parts;
- additional sails;
- personal safety and life-saving equipment;
- provisions;
- bilge water;
- waste water;
- potable water;
- fuel;
- portable fuel tanks;
- personal equipment;
- life-raft(s);
- dinghy(s);
- persons.

NOTE Liferafts are not included in essential safety equipment for design categories C and D.

### 6.4 Performance test mass, $m_p$

The performance test mass ( $m_p$ ) of a craft shall include all permanently attached standard items of equipment. Further, the craft shall be fitted with all items of loose equipment needed for the safe operation of the craft, for example,

- a) warps,
- b) anchors/chain/ropes,

- c) engine(s), and
- d) batteries.

In addition, the masses of the following shall be included:

- e) number of persons needed for the safe operation of the craft;
- f) fuel at least at 25 %, but no more than 50 % of the tank capacity of permanently installed fuel tanks, or one portable tank per engine, which shall be at least 50 % full at the beginning of each test trial;
- g) personal safety equipment for all people on board.

Excluded are the following:

- fresh water;
- waste water;
- provisions;
- loose equipment, e.g. cutlery, crockery, kitchen utensils, spare parts, etc.

## 6.5 Mass of the craft when towed on a trailer, $m_T$

### 6.5.1 General

The mass of the craft when towed on a trailer ( $m_T$ ) shall only be established for craft advertised as trailerable to allow the owner/user to identify the mass of additional equipment that may be carried without exceeding the trailer capacity.

The mass,  $m_T$ , shall include items of equipment as listed under [6.5.2](#), plus fastenings to secure the craft on the trailer.

The manufacturer/dealer shall provide a list of parts, components, and equipment that are included in the mass,  $m_T$ , as defined above and shall state the total sum, in kilograms (kg). This may be in the format of general or itemized descriptions (for items included).

Any items of equipment normally supplied by the manufacturer/dealer not intended to be placed in the craft or on the trailer shall be listed separately.

### 6.5.2 Items of equipment included in $m_T$

#### 6.5.2.1 Structure

The structure is made up of all structural parts, including ballast keel and/or centreboard/daggerboard(s) and rudder(s).

If loose ballast or parts of the ballast keel are not to be stowed on the trailer, these parts shall be specifically declared and listed under the non-included equipment (see [6.5.3](#)).

#### 6.5.2.2 Internal structure and accommodation

The internal structure and accommodation are made up of bulkheads and partitions, insulation, lining, built-in furniture, flotation material, windows, hatches and doors, and upholstery material.

### 6.5.2.3 Internal equipment

The internal equipment includes the following:

- all items of equipment permanently attached to the craft, e.g. toilet system(s), water transfer equipment, bilge pumping system(s), cooking and heating devices, cooling equipment, ventilation system(s);
- electrical installation and equipment, including batteries installed or delivered with the craft;
- fixed navigational and electronic equipment;
- fire-fighting equipment, where fitted;
- mattresses, curtains.

### 6.5.2.4 External equipment

For all craft, this includes the following:

- all permanently attached deck fittings, e.g. guardrails, pulpits and pushpits, bowsprits, and their attachments;
- bathing platforms, boarding ladders, steering equipment, winches, sprayhood(s), awning(s), cockpit tables, gratings;
- signal mast(s);
- anchor(s), anchor warps and chains;
- loose external equipment, e.g. fenders, warps, painters.

For craft with sailing rig(s), this includes the following:

- mast(s), boom(s), spinnaker and other pole(s), standing and running rigging, all upwind sails supplied or recommended by the builder, onboard and rigged ready for use, but not hoisted, e.g. mainsail on boom, roller furling sails furled, hanked foresails on stay stowed on foredeck.

### 6.5.2.5 Engine and fuel system

#### 6.5.2.5.1 Permanently installed engine and fuel systems

The permanently installed engine and fuel systems are comprised of inboard engine(s), including all supplies and controls as needed for their operation, and permanently installed fuel systems including tanks.

#### 6.5.2.5.2 Outboard engines

The mass of the craft shall be stated with the mass of the outboard motor(s) and related equipment as follows:

- mass of the heaviest engine(s), as recommended by the craft manufacturer, irrespective of the fact that the manufacturer may have fitted a lighter engine;
- mass of any permanently installed fuel system;
- mass of engine controls and steering system.

#### 6.5.2.6 Tanks, tank contents

Tanks, tank contents include the following:

- contents of permanently installed fuel tanks;
- portable tanks and their contents;
- contents of fresh water tanks.

The mass of the liquids shall be calculated or measured up to the full usable tank volume.

#### 6.5.3 Items of equipment not included in $m_T$

Items of equipment not included in  $m_T$  are the following:

- loose internal equipment, e.g. cutlery, crockery, kitchen utensils, linen;
- loose electronic and navigational equipment (e.g. charts);
- tools, spare parts;
- additional sails;
- personal safety and life-saving equipment;
- provisions;
- bilge water;
- ballast water;
- sewage water;
- bait tanks.

#### 6.5.4 Exclusions, inclusions

The manufacturer/dealer may exclude items of equipment listed in [6.5.2](#) (inclusions) which shall then be specifically declared in the list of exclusions. These shall not include structural parts of the craft or permanently attached items of equipment needed for the safe operation of the craft.

If intending to include items listed in [6.5.3](#) (exclusions), the manufacturer shall amend the list of items included by adding these items of equipment.

#### 6.6 Maximum load, $m_{ML}$

Load which the craft is designed to carry in addition to the light craft condition, comprised of the following:

- the crew limit at 75 kg each;
- the personal effects of the crew;
- stores and cargo (if any), dry provisions, consumable liquids;
- contents of all permanently installed storage tanks filled to 95 % of their maximum capacity including fuel, drinking water, black water, grey water, lubricating and hydraulic oil, bait tanks and/or live wells plus ballast water at 100 % capacity;
- consumable liquids in portable tanks (drinking water, fuel) filled to 95 % of the maximum capacity;
- dinghy or other craft intended to be carried aboard and any outboard motor associated with them;

- liferaft(s), if carried in excess of the minimum required in essential safety equipment;
- non-edible stores and equipment normally carried on the craft and not included in the manufacturer's list of standard equipment, e.g. loose internal equipment and tools, spare parts, and additional anchors.

NOTE Liferafts are not included in essential safety equipment for design categories C and D. See ISO 12217 (all parts)<sup>[1]</sup> for the description of design categories.

As a guide, not less than 20 kg per person should be allowed for personal effects on habitable craft.

## 7 Loading conditions

### 7.1 Test condition

For the determination of the manoeuvring speed and maximum powering, the craft shall be equipped with masses according to [6.4](#).

### 7.2 Ready-for-use condition

The craft is in ready-for-use condition when it is fully equipped for the intended use with the following:

- filled-up fuel tanks;
- filled-up fresh water tanks;
- water in bait tanks and live wells to their designated limit.

The masses of the liquids shall be measured or calculated up to the full usable tank volume.

The masses of outboard motors and batteries shall correspond to the highest power rating with which the craft is intended to be equipped and to operate.

### 7.3 Fully loaded ready-for-use condition

The craft is equipped and loaded according to [7.2](#), but also includes the following:

- the mass of the persons (at 75 kg each) the craft is designed to carry, in their normal seating position in the cockpit;
- the mass of personal equipment and basic equipment of the craft of  $(L_H - 2,5)^2$  kg, but not less than 10 kg;
- the mass of a life-raft(s) and/or dinghy(s) when intended to be carried.

The designer/manufacturer shall declare the mass and the related draught of the craft for this loading condition.

### 7.4 Empty craft condition

Empty craft, including fittings and equipment as listed below, but excluding all optional equipment and fittings not included in the manufacturer's basic outfit.

- Structure:** Comprising all the structural parts, including any fixed ballast keel and/or drop keel, centreboard, daggerboard(s), and rudder(s). Any centreboard or keel is in the raised position, unless it can be fixed in the lowered position and an appropriate instruction is given in the owner's manual.
- Ballast:** Any fixed ballast installed.

- c) Internal structure and accommodation: Bulkheads and partitions, insulation, lining, built-in furniture, flotation material, windows, hatches and doors, permanently installed mattresses, and upholstery materials.
- d) **Permanently installed engine(s) and fuel system:** Comprising inboard engine(s), including all supplies and controls as needed for their operation, permanently installed fuel systems, including tanks.
- e) **Fluids in permanently installed systems:** Residual working fluids as needed for their operation (see examples below), but excluding contents of fluid ballast systems and tanks, and main storage tanks which are included in maximum load.

EXAMPLE Fluids in hot or cold water, fuel, lubricating, or hydraulic oil systems.

- f) Internal equipment, including the following:
  - 1) all items of equipment permanently attached to the craft, e.g. tanks, toilet system(s), water transfer equipment;
  - 2) bilge pumping system(s), cooking and heating devices, cooling equipment, ventilation system(s);
  - 3) electrical installation and equipment, including permanently installed batteries mounted in the position intended by the builder;
  - 4) fixed navigational and electronic equipment;
  - 5) fixed fire fighting equipment, where fitted.
- g) External equipment, including the following:
  - 1) all permanently attached standard or specified deck fittings, e.g. guardrails, pulpits and pushpits, bowsprits and their attachments, bathing platforms, boarding ladders, steering equipment, winches, sprayhood(s);
  - 2) awning(s), cockpit tables, gratings, signal mast(s), where fitted;
  - 3) mast(s), boom(s), standing and running rigging, in the stowed position ready for use, but not set, all standing and running rigging in place.

## 7.5 Light craft condition

Empty craft condition, plus standard equipment, plus removable ballast (whether solid or liquid) when supplied and/or intended by the manufacturer to be carried when the craft is afloat, with elements positioned as follows:

- a) where provision is made for propulsion by outboard engine(s) of more than 3 kW, the heaviest engine(s) recommended for the craft by the manufacturer is(are) mounted in the working position(s);
- b) where batteries are fitted, they are mounted in the position intended by the builder and if there is no specific stowage provided for batteries, the mass of one battery for each engine over 7 kW is allowed for, and located within 1,0 m of the engine location;
- c) all upwind sails supplied or recommended by the builder, onboard and rigged ready for use, but not hoisted, e.g. mainsail on boom, roller furling sails furled, hanked foresails on stay stowed on foredeck;
- d) unless otherwise required, variable position elements (e.g. canting keels, movable solid ballast, tilting masts) are positioned symmetrically about the centreline of the craft.



## 7.6 Minimum operating condition

Craft in the light craft condition with the following additions:

- a) mass to represent the crew, positioned on the centreline near the main control position of the following:
  - 1) 75 kg where  $L_H \leq 8$  m;
  - 2) 150 kg where  $8 \text{ m} < L_H \leq 16$  m;
  - 3) 225 kg where  $16 \text{ m} < L_H < 24$  m;
- b) nonedible stores and equipment normally carried on the craft and not included in the manufacturer's list of standard equipment.

EXAMPLE Loose internal equipment and tools, spare parts, dishes, kitchenware and cutlery, additional anchors, dinghy, and outboard if carried aboard.

NOTE 1 Liquids in main storage tanks (e.g. fuel, drinking water, black and grey water, live wells, bait tanks, etc.) are excluded.

NOTE 2 Water ballast in tanks which are symmetrical about the centreline and which are intended by the builder to be used for variable asymmetric ballasting while under way is excluded.

## 7.7 Loaded arrival condition

Craft in the maximum load condition minus 85 % of the maximum capacity of fixed or portable storage tanks for fuel, oils, and drinking water and minus 90 % of edible stores, but including the worst combination of optional fittings or equipment with respect to stability.

## 7.8 Maximum load condition

Craft in the light craft condition with the maximum load added and an allowance for the maximum mass of optional equipment and fittings not included in the manufacturer's basic outfit so as to produce the design trim, the crew being in positions typically used when the craft is underway.

# 8 Tolerances

## 8.1 Published data

Data are considered published if used as a specification in brochures or other written material used for marketing the craft. Published data shall be within the tolerances given in [Table 2](#). The tolerances given in [Table 2](#) do not apply to data in Technical Documentations which are used for the assessment and/or certification of a craft.

**Table 2 — Tolerances for published data**

Values in percent

<b>Published data</b>	<b>Tolerance</b>
Linear dimensions, rigid craft	±1
Linear dimensions, inflatable boats	±2,5
Sail areas	±5
Displacement	±10
Volumes	±5
Masses	±5
Speed <sup>a</sup>	±5
NOTE Certain critical data will affect the permissible tolerances, e.g. maximum beam or maximum mass of the craft when towed on the trailer. In these cases, the plus-tolerance does not apply.	
<sup>a</sup> This speed relates to the craft in the test condition according to <a href="#">6.4</a> if no other mass or loading condition is specified.	

## 8.2 Preliminary specification

Preliminary specification of dimensions, displacement, and masses shall be identified by an appropriate term such as “preliminary”, “approximate”, “estimate”, “varies”, etc. If this applies, the tolerance shall not exceed ± 5 % on dimensions and ± 15 % on masses/displacement and volumes.

## 8.3 Reference lengths

References to length of hull “from 2,5 m” shall be taken as meaning “greater than or equal to 2 500 mm”.

References to length of hull “longer than 6 m” shall be taken as meaning “greater than 6 000 mm”.

References to length of hull “up to 24 m” shall be taken as meaning “less than 24 000 mm”.

References to length of hull “to 12 m” shall be taken as meaning “less than or equal to 12 000 mm”.

References to length of hull “less than 6 m” shall be taken as meaning “less than 6 000 mm”.

## Bibliography

- [1] ISO 12217 (all parts), *Small craft — Stability and buoyancy assessment and categorization*





## Bureau of Indian Standards

BIS is a statutory institution established under the *Bureau of Indian Standards Act, 2016* to promote harmonious development of the activities of standardization, marking and quality certification of goods and attending to connected matters in the country.

### Copyright

BIS has the copyright of all its publications. No part of these publications may be reproduced in any form without the prior permission in writing of BIS. This does not preclude the free use, in the course of implementing the standard, of necessary details, such as symbols and sizes, type or grade designations. Enquiries relating to copyright be addressed to the Head (Publication & Sales), BIS.

### Review of Indian Standards

Amendments are issued to standards as the need arises on the basis of comments. Standards are also reviewed periodically; a standard along with amendments is reaffirmed when such review indicates that no changes are needed; if the review indicates that changes are needed, it is taken up for revision. Users of Indian Standards should ascertain that they are in possession of the latest amendments or edition by referring to the website- [www.bis.gov.in](http://www.bis.gov.in) or [www.standardsbis.in](http://www.standardsbis.in).

This Indian Standard has been developed from Doc No.: TED 18 (23917).

### Amendments Issued Since Publication

Amend No.	Date of Issue	Text Affected

## BUREAU OF INDIAN STANDARDS

### Headquarters:

Manak Bhavan, 9 Bahadur Shah Zafar Marg, New Delhi 110002  
Telephones: 2323 0131, 2323 3375, 2323 9402

Website: [www.bis.gov.in](http://www.bis.gov.in)

### Regional Offices:

	Telephones
Central : 601/A, Konnectus Tower -1, 6 <sup>th</sup> Floor, DMRC Building, Bhavbhuti Marg, New Delhi 110002	{ 2323 7617
Eastern : 8 <sup>th</sup> Floor, Plot No 7/7 & 7/8, CP Block, Sector V, Salt Lake, Kolkata, West Bengal 700091	{ 2367 0012 2320 9474
Northern : Plot No. 4-A, Sector 27-B, Madhya Marg, Chandigarh 160019	{ 265 9930
Southern : C.I.T. Campus, IV Cross Road, Taramani, Chennai 600113	{ 2254 1442 2254 1216
Western : Manakalya, 5 <sup>th</sup> Floor/MTNL CETTM, Technology Street, Hiranandani Gardens, Powai Mumbai 400076	{ 25700030 25702715

**Branches :** AHMEDABAD, BENGALURU, BHOPAL, BHUBANESHWAR, CHANDIGARH, CHENNAI, COIMBATORE, DEHRADUN, DELHI, FARIDABAD, GHAZIABAD, GUWAHATI, HARYANA (CHANDIGARH), HUBLI, HYDERABAD, JAIPUR, JAMMU, JAMSHEDPUR, KOCHI, KOLKATA, LUCKNOW, MADURAI, MUMBAI, NAGPUR, NOIDA, PARWANOO, PATNA, PUNE, RAIPUR, RAJKOT, SURAT, VIJAYAWADA.