अग्नि प्रतिरोधिता परीक्षण —
दरवाजे और शटर समुच्चय
भाग 1 सामान्य अपेक्षाएँ

**Fire Resistance Tests —
Door and Shutter Assemblies**
Part 1 General Requirements

ICS 13.220.50; 91.060.50

© BIS 2022



भारतीय मानक ब्यूरो
BUREAU OF INDIAN STANDARDS
मानक भवन, 9 बहादुरशाह ज़फर मार्ग, नई दिल्ली – 110002
MANAK BHAVAN, 9 BAHADUR SHAH ZAFAR MARG
NEW DELHI-110002
www.bis.gov.in www.standardsbis.in

NATIONAL FOREWORD

This Indian Standard (Part 1) which is identical with ISO 3008-1 : 2019 'Fire resistance tests — Door and shutter assemblies — Part 1: General requirements' issued by the International Organization for Standardization (ISO) was adopted by the Bureau of Indian Standards on recommendation of the Fire Safety Sectional Committee and approval of the Civil Engineering Division Council.

The standard is published in four parts. The other parts in this series are:

- Part 2 Lift landing door assemblies
- Part 3 Door and shutter assemblies horizontally oriented
- Part 4 Linear joint fire seal materials used to seal the gap between a fire door frame and the supporting construction

The text of ISO Standard has been approved as suitable for publication as an Indian Standard without deviations. Certain conventions and terminologies are, however, not identical to those used in Indian Standards. Attention is particularly drawn to the following:

- a) Wherever the words 'International Standard' appear referring to this standard, they should be read as 'Indian Standard'.
- b) Comma (,) has been used as a decimal marker, while in Indian Standards, the current practice is to use a point (.) as the decimal marker.

In this adopted standard, reference appears to certain International Standards for which Indian Standards also exist. The corresponding Indian Standards, which are to be substituted in their respective places, are listed below along with their degree of equivalence for the editions indicated:

<i>International Standard</i>	<i>Corresponding Indian Standard</i>	<i>Degree of Equivalence</i>
ISO 834-1 Fire-resistance tests — Elements of building construction — Part 1: General requirements	IS/ISO 834-1 : 1999 Fire-resistance tests — Elements of building construction — Part 1: General requirements	Identical with ISO 834-1 : 1999
ISO 834-8 Fire-resistance tests — Elements of building construction — Part 8: Specific requirements for non-loadbearing vertical separating elements	IS/ISO 834-8 : 2002 Fire-resistance tests — Elements of building construction — Part 8: Specific requirements for non-load bearing vertical separating elements	Identical with ISO 834-8 : 2002
ISO 3009 Fire-resistance tests — Elements of building construction — Glazed elements	IS/ISO 3009 : 2003 Fire-resistance tests — Elements of building construction — Glazed elements	Identical with ISO 3009 : 2003
ISO 13943 Fire safety — Vocabulary	IS 8757 : 2021 Glossary of terms associated with fire safety (<i>second revision</i>)	Technically Equivalent

In reporting the result of a test or analysis made in accordance with this standard, if the final value, observed or calculated, expressing the result of a test or analysis shall be rounded off in accordance with IS 2 : 2022 'Rules for rounding off numerical values (*second revision*)'.

Introduction

This document contains specific requirements for fire-resistance testing which are unique to the elements of building construction described as doors and shutters. The requirements for these doors and shutters are intended to be applied in appropriate conjunction with the detailed and general requirements contained in ISO 834-1.

This page has been intentionally left blank

Indian Standard

FIRE RESISTANCE TESTS — DOOR AND SHUTTER ASSEMBLIES

PART 1 GENERAL REQUIREMENTS

CAUTION — The attention of all persons concerned with managing and carrying out this fire-resistance test is drawn to the fact that fire testing may be hazardous and that there is a possibility that toxic and/or harmful smoke and gases may be evolved during the test. Mechanical and operational hazards can also arise during the construction of the test elements or structures, their testing and disposal of test residues.

An assessment of all potential hazards and risks to health shall be made and safety precautions shall be identified and provided. Written safety instructions shall be issued. Appropriate training shall be given to relevant personnel. Laboratory personnel shall ensure that they follow written safety instructions at all times.

1 Scope

This document, used in conjunction with ISO 834-1, specifies a method for determining the fire resistance of door and shutter assemblies designed primarily for installation within openings incorporated in vertical separating elements, such as

- hinged and pivoted doors,
- horizontally sliding and vertically sliding doors, including articulated sliding doors and sectional doors,
- steel single-skin folding shutters (un-insulated),
- other sliding, folding doors,
- tilting doors,
- rolling shutter doors,
- removable panels in walls,
- self-closing openable windows.

Requirements are included for mechanical pre-conditioning, e.g. “cycling” of door and shutter assemblies prior to the conduct of the fire-resistance test.

2 Normative references

The following documents are referred to in the text in such a way that some or all of their content constitutes requirements of this document. For dated references, only the edition cited applies. For undated references, the latest edition of the referenced document (including any amendments) applies.

ISO 834-1, *Fire-resistance tests — Elements of building construction — Part 1: General requirements*

ISO 834-8, *Fire-resistance tests — Elements of building construction — Part 8: Specific requirements for non-loadbearing vertical separating elements*

ISO 3009, *Fire-resistance tests — Elements of building construction — Glazed elements*

ISO 13943, *Fire safety — Vocabulary*

3 Terms and definitions

For the purposes of this document, the terms and definitions given in ISO 834-1, ISO 13943 and the following apply.

ISO and IEC maintain terminological databases for use in standardization at the following addresses:

- IEC Electropedia: available at <http://www.electropedia.org/>
- ISO Online browsing platform: available at <https://www.iso.org/obp>

3.1 **associated supporting construction**

specific construction in which the door or shutter assembly is installed as intended for use in practice and which is used to close off the furnace and provide the levels of restraint and thermal heat transfer to be experienced in normal use

3.2 **cill**

member that spans between two frame jambs at the base, which might or might not be set into the floor, and that remains visible

3.3 **door assembly** **door set**

complete assembly, consisting of pivoted, hinged or sliding door leaves or leaf including any frame that is provided for closing of permanent openings in separating elements

Note 1 to entry: This includes all side panels, vision panels or transom panels. The assembly shall be complete with grilles and louvers together with the door hardware and any fire seals, smoke seals, draught seals, acoustic seals that are used in the assembly.

3.4 **door hardware**

items such as hinges, handles, locks, panic bar(s), escutcheons, letter plates, kick plates, sliding gear, closing devices, electrical components, wiring, etc., that are, or can be, used in the door or shutter assembly

3.5 **double action**

action of a fire door leaf that opens in both directions

3.6 **fire seal**

seal fitted to the frame or to the leaf edge for the purpose of extending the period of integrity of the assembly

3.7 **floor**

upper surface of the horizontal element on which the door or shutter assembly is mounted and which extends from the exposed face to the unexposed face of the assembly

3.8 **flush over panel**

fixed panel fitted within the head and jambs above the door leaf without a transom fitted

3.9 **gap**

clearance between two nominally adjacent surfaces and/or edges, e.g. between the edge of a leaf and the frame or face of the leaf and the frame stop

3.10

primary leaf

leaf of a multi-leaved door assembly that is the largest and/or has the handle attached to it as the preferred leaf for general operation

Note 1 to entry: If the leaves of a multi-leaved door are the same size and if the handles (or other hardware such as push plates) are fitted to all leaves, then no primary leaf exists for that door assembly.

3.11

shutter assembly

complete assembly consisting of rolling, folded or sliding curtains, including guides, rollers, tracks, and operating mechanism and housings

3.12

side panel

fixed panel that is incorporated to one side of a door that is part of the test specimen

3.13

single action

action of a fire door leaf that opens in only one direction

3.14

smoke seal

seal fitted to the frame or to the leaf edge for the purpose of restricting the flow of smoke or hot gases

3.15

standard supporting construction

form of construction used to close off the furnace and to support the door or shutter assembly being evaluated and which has a quantifiable influence on both the thermal heat transfer between the construction and the test specimen and provides known resistance to thermal distortion

3.16

test specimen

door or shutter assembly that is installed in a standard or associated supporting construction to allow its evaluation

3.17

through connection

fixing or internal spacer that either penetrates through the door or shutter construction from one face to another or directly connects the faces one to the other

3.18

transom

member that extends across the frame from jamb to jamb at the head of the leaf and that creates an aperture to house a transom panel

3.19

transom panel

fixed panel that is incorporated above a door and is bounded on all edges by either the frame head, the jambs or the transom

3.20

air transfer grille

product which is installed in an aperture in a door or shutter assembly that allows a path for air movement through the door or shutter assembly

3.21

reactive air transfer grille

air transfer grille that resists the spread of fire and hot gases by the activation of its intumescent components

3.22

mechanical air transfer grille

air transfer grille that resists the spread of fire and hot gases by the closure of blades, plates or slats which are normally in the open position.

4 Test equipment

4.1 The test equipment shall be as specified in ISO 834-1. The furnace used shall be related to the orientation of the test specimen. For vertical specimens, the wall testing furnace is suitable, for horizontal specimens, the floor furnace is applicable.

4.2 Measurement of heat flux from the unexposed surface of specimens shall be made as described in [9.5](#).

4.3 Where it is not possible to apply disc thermocouples as specified in ISO 834-1 to the unexposed surface of the test specimen, due to the size or shape of the specimen, or when the dimension of the element to be measured is less than 12 mm, such as when testing air transfer grilles, an alternate thermocouple and pad may be used. Instead of copper discs, twisted thermocouple wire may be used. The wire leads of the thermocouple are to have an immersion under the pad and be in contact with the unexposed surface for not less than 25 mm. The hot junction of the thermocouple is to be placed approximately under the centre of the pad. The pad is permitted to be deformed in order to be held firmly against the surface of the element being measured and is to fit closely about the thermocouple. When the blade of the air transfer grille or other parts of the test specimen is less than the specified pad size, reduce the pad to match the element being measured. The pad length shall be as specified and parallel to the test specimen length. If the modified thermocouple pad cannot be placed on the contour of the surface, then no thermocouple is required at that location. The wires for the thermocouple in the length covered by the pad shall not be heavier than 0,82 mm² and are to be electrically insulated with heat-resistant and moisture-resistant coatings.

5 Test conditions

Test conditions require the application of the heating and pressure conditions of the standard test as defined in ISO 834-1.

6 Test specimen

6.1 Size of specimen

The test specimen and all its components shall be full size. When this is restricted by the size of the opening of the furnace (which is normally 3 m × 3 m), the door or shutter assembly or the self-closing openable window shall be tested at the maximum size possible and the fire resistance of the full sized assembly shall be derived by an extended application analysis. However, the minimum dimensions of supporting construction shall not be less than that prescribed in [7.3.1](#).

6.2 Number of specimens

The number of test specimens shall be selected as described in ISO 834-1. If testing is carried out from one side only, it shall be stated in the test report whether this is due to the symmetrical nature of the door or because it is required to resist fire from one side only.

6.3 Design of specimen

6.3.1 The design of the test specimen and the choice of supporting construction shall take into account the requirements of [7.3](#) if the widest field of direct application is to be achieved.

6.3.2 Where the door or shutter assembly incorporates air transfer grilles or side, transom or flush over panels, whether glazed or unglazed, these shall be tested as part of the door or shutter assembly. The side panel shall always be on the latch side.

6.3.3 The test specimen shall be fully representative of the door or shutter assembly as intended for use in practice, including any appropriate surface finishes and fittings that are an essential part of the specimen and that can influence its behaviour in a test construction.

6.4 Construction

The test specimen shall be constructed as described in ISO 834-1.

6.5 Verification

6.5.1 The sponsor shall provide a specification to a level of detail sufficient to allow the laboratory to conduct a detailed examination of the specimen before the test and to agree on the accuracy of the information supplied. ISO 834-1 provides detailed guidance on verification of the test specimen.

6.5.2 When the method of construction precludes a detailed survey of the specimen without having to permanently damage it, or if it is considered that it will subsequently be impossible to evaluate construction details from a post-test examination, then one of two options shall be exercised by the laboratory:

- either the laboratory shall oversee the manufacture of the door or shutter assembly(ies) subjected to the test, or
- the sponsor shall, at the discretion of the laboratory, be requested to supply an additional assembly or that part of the assembly that cannot be verified (e.g. a door leaf) in addition to the number required for the testing. The laboratory shall then choose freely which of these shall be subjected to the testing and which shall be used to verify the construction.

7 Installation of test specimen

7.1 General

7.1.1 The test specimen shall be installed as intended for use in practice, incorporating all hardware and other items that can influence the performance of the specimen.

7.1.2 The test specimen shall be mounted in a supporting construction, the field of application of which covers the type (see [7.3.1](#)) in which it is intended for use. The design of the connection between the test specimen and the supporting construction, including any fixings and materials used to make the connection, shall be as intended for use in practice and shall be regarded as part of the test specimen.

7.1.3 The whole area of the test specimen, together with at least the minimum dimensions of the supporting construction required by [7.3.1](#), shall be exposed to the heating conditions.

7.2 Supporting construction

The fire resistance of any supporting construction shall not be determined from a test in conjunction with a test specimen and shall be at least commensurate with that anticipated for the test specimen.

7.3 Test construction

7.3.1 Associated and supporting construction

The space between the specimen and the frame shall be filled with either

- associated construction, or
- supporting construction.

There shall be a minimum zone, 200 mm wide, of supporting construction exposed within the furnace each side and over the top of the aperture into which the test specimen is fixed. The thickness of the supporting construction may be increased outside of the 200 mm zone. The test construction may incorporate more than one test specimen providing that there is a minimum separation of 200 mm between each specimen and between the specimens and the edge of the furnace.

7.3.2 Associated construction

When the test specimen is always installed in a specific, normally proprietary form of construction, that is permanently associated with its intended use in practice, then the specimen shall be installed in a sample of this associated construction.

7.3.3 Supporting construction

7.3.3.1 Where the test specimen is not permanently associated with a specific form of construction, the area between the test specimen and the support frame shall be filled with a rigid or flexible standard supporting construction as specified in ISO 834-8.

7.3.3.2 The choice of standard supporting construction shall reflect the range of intended use for the door or shutter assembly. The rules governing the applicability of the chosen standard supporting construction to other end use situations are given in [Clause 13](#).

7.3.3.3 [Figures 1](#) to [8](#) illustrate the use of supporting constructions in conjunction with the mounting of specimens of different types.

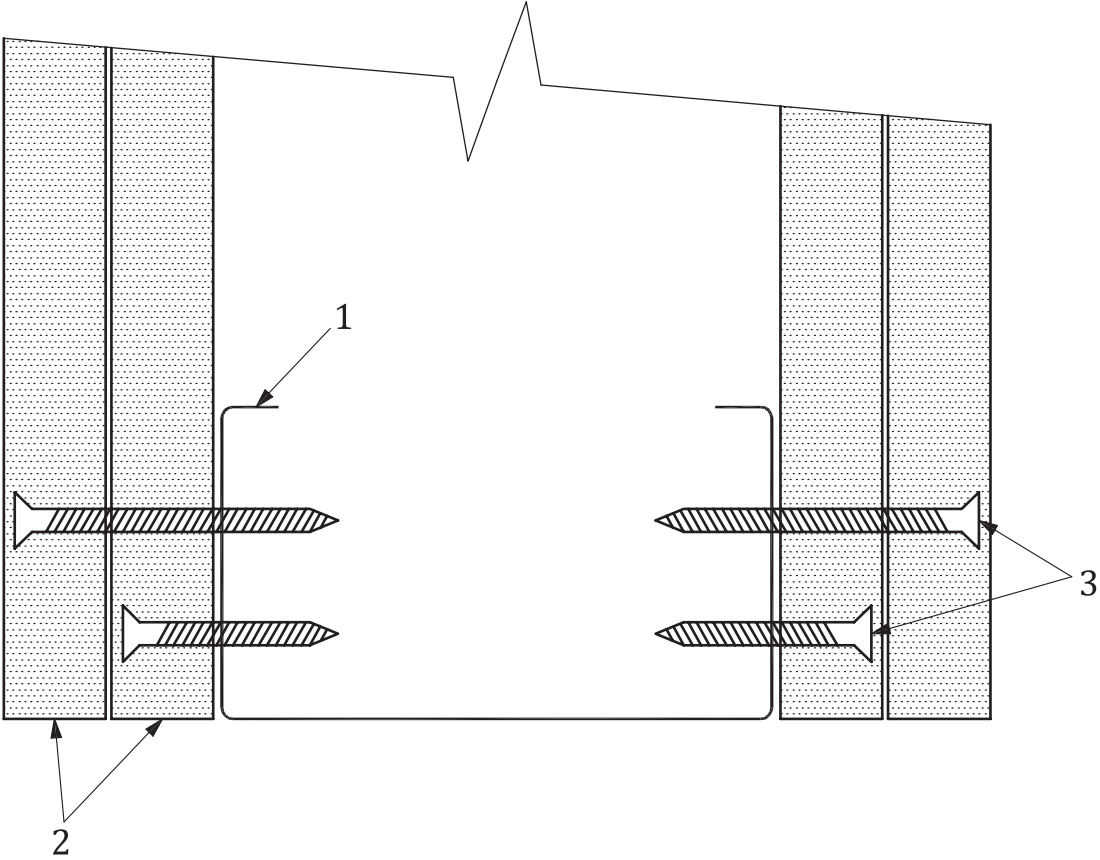

Key

- 1 steel vertical "C" stud
- 2 12,5 mm plasterboard
- 3 screws at 300 mm fixing centres

Figure 1 — Example of a horizontal cross-section of a flexible standard supporting construction

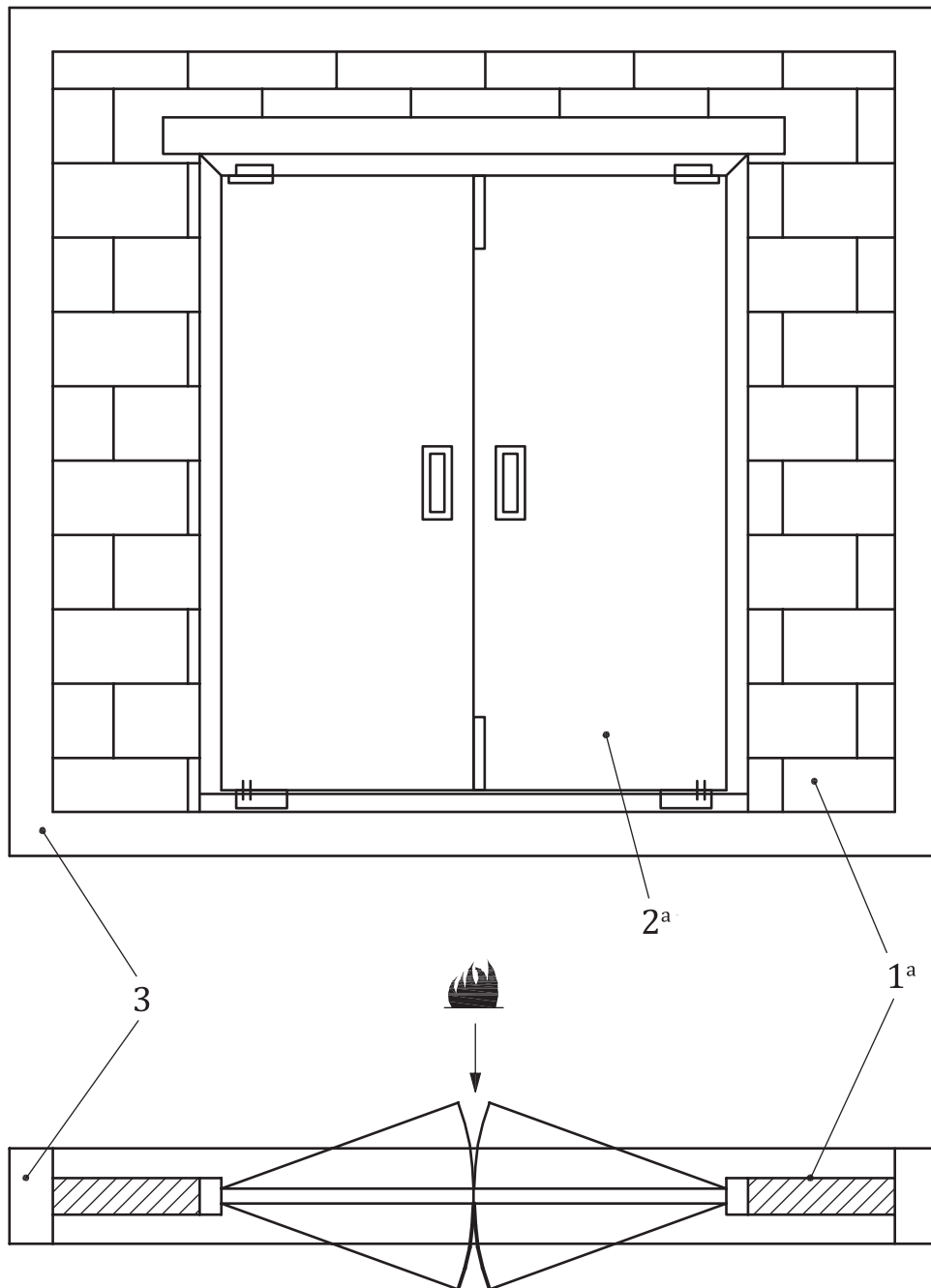

Key

- 1 standard supporting construction (block wall)
- 2 door assembly (test specimen)
- 3 test frame
- a Key items 1 and 2 form the test construction.

Figure 2 — Example of door assembly in a rigid standard supporting construction

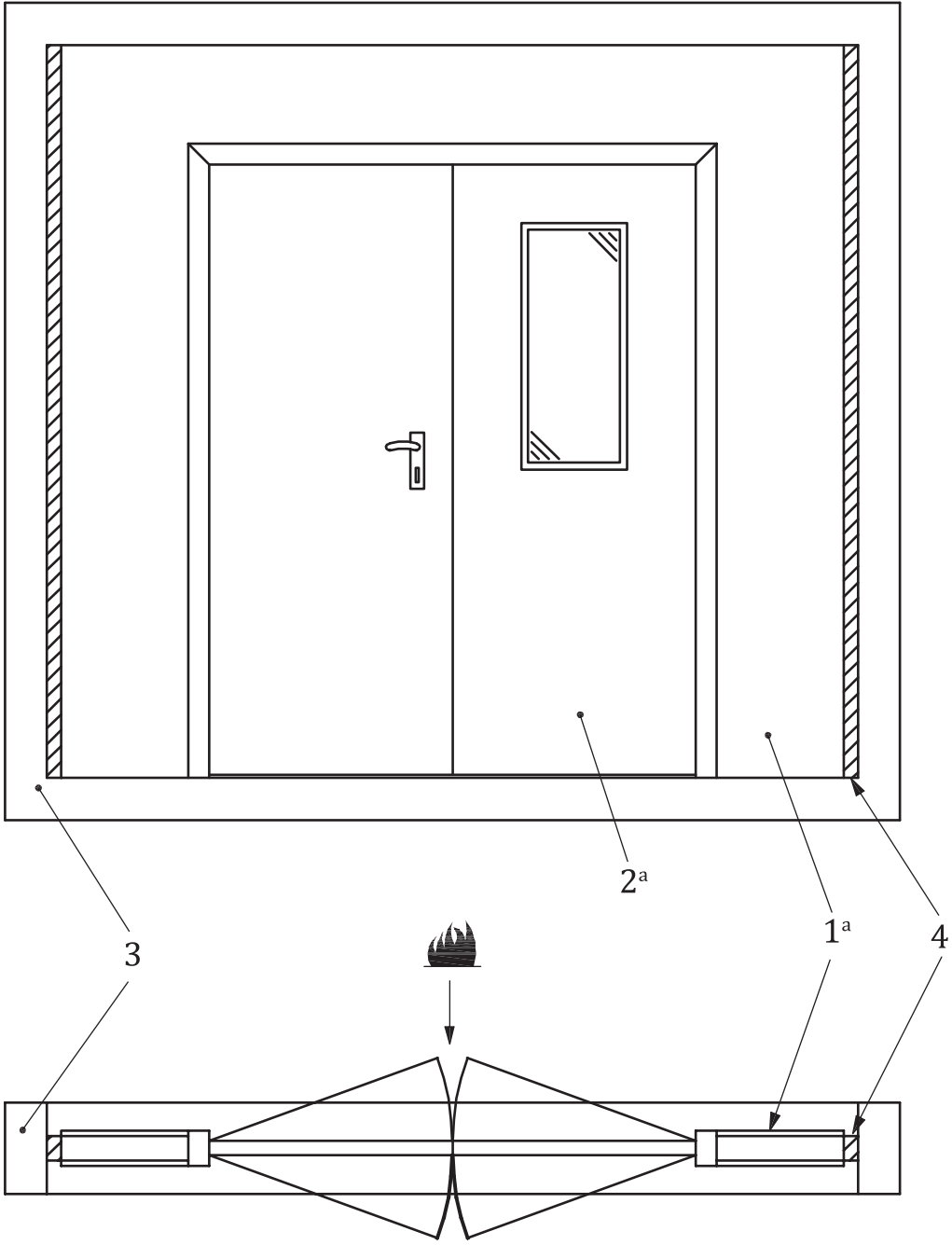

Key

- 1 standard or associated supporting construction
- 2 door assembly (test specimen)
- 3 test frame
- 4 free edge insulation
- a Key items 1 and 2 form the test construction.

Figure 3 — Example of a door assembly in flexible standard or associated supporting construction

Dimensions in millimetres

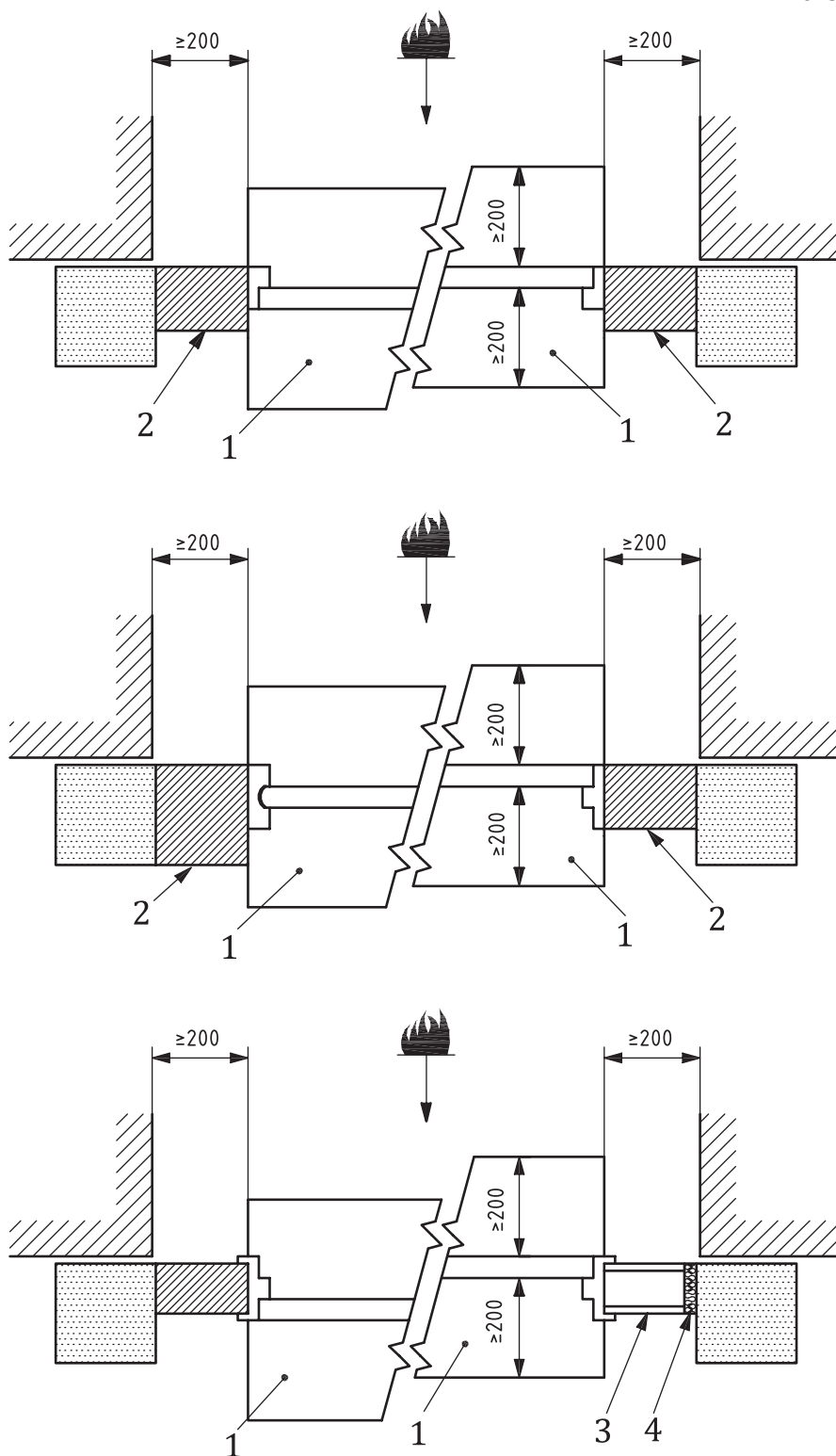

Key

- 1 floor
- 2 standard supporting construction
- 3 associated supporting construction
- 4 free edge insulation

Figure 4 — Example of horizontal sections for mounting hinged door specimens

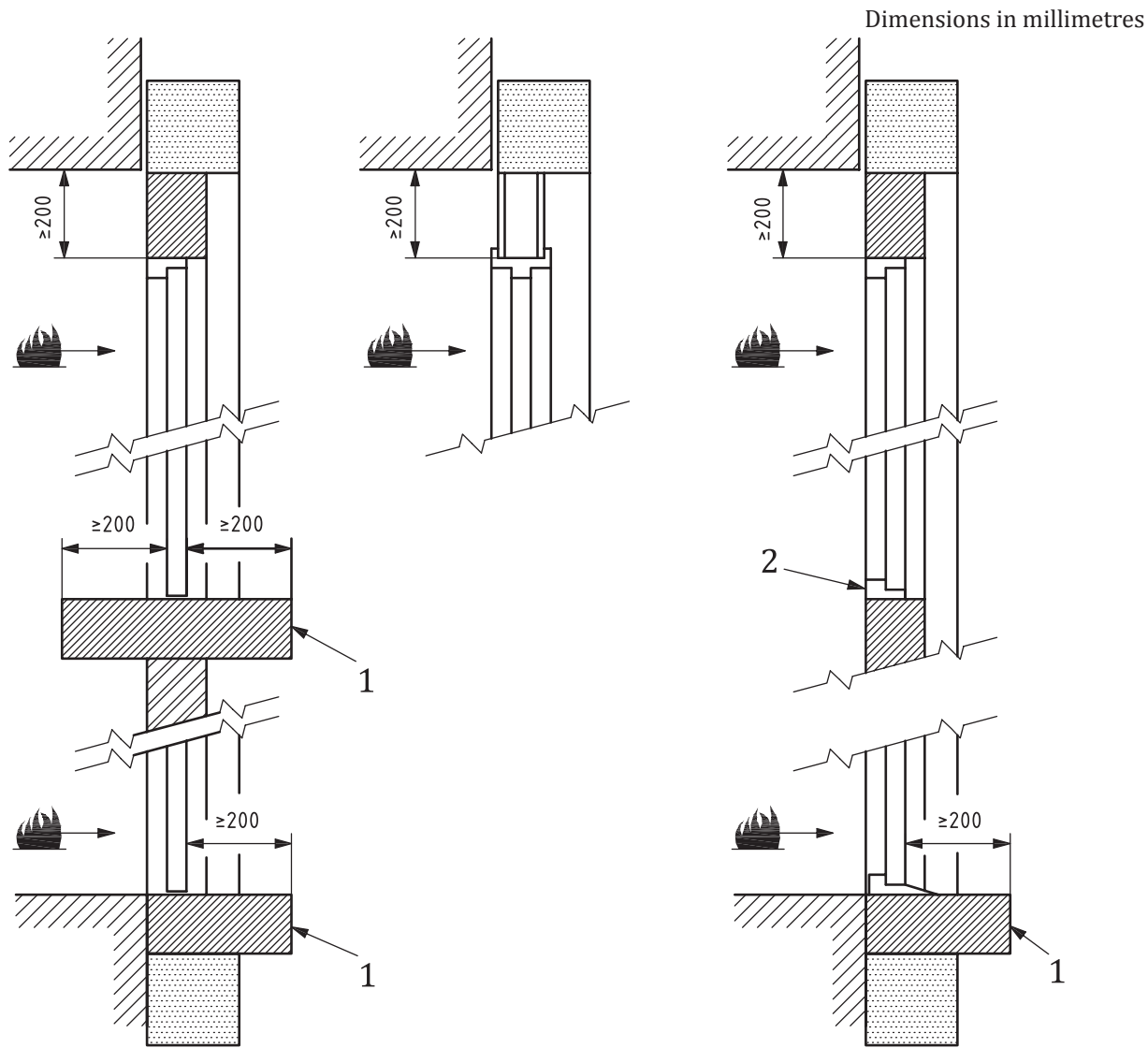
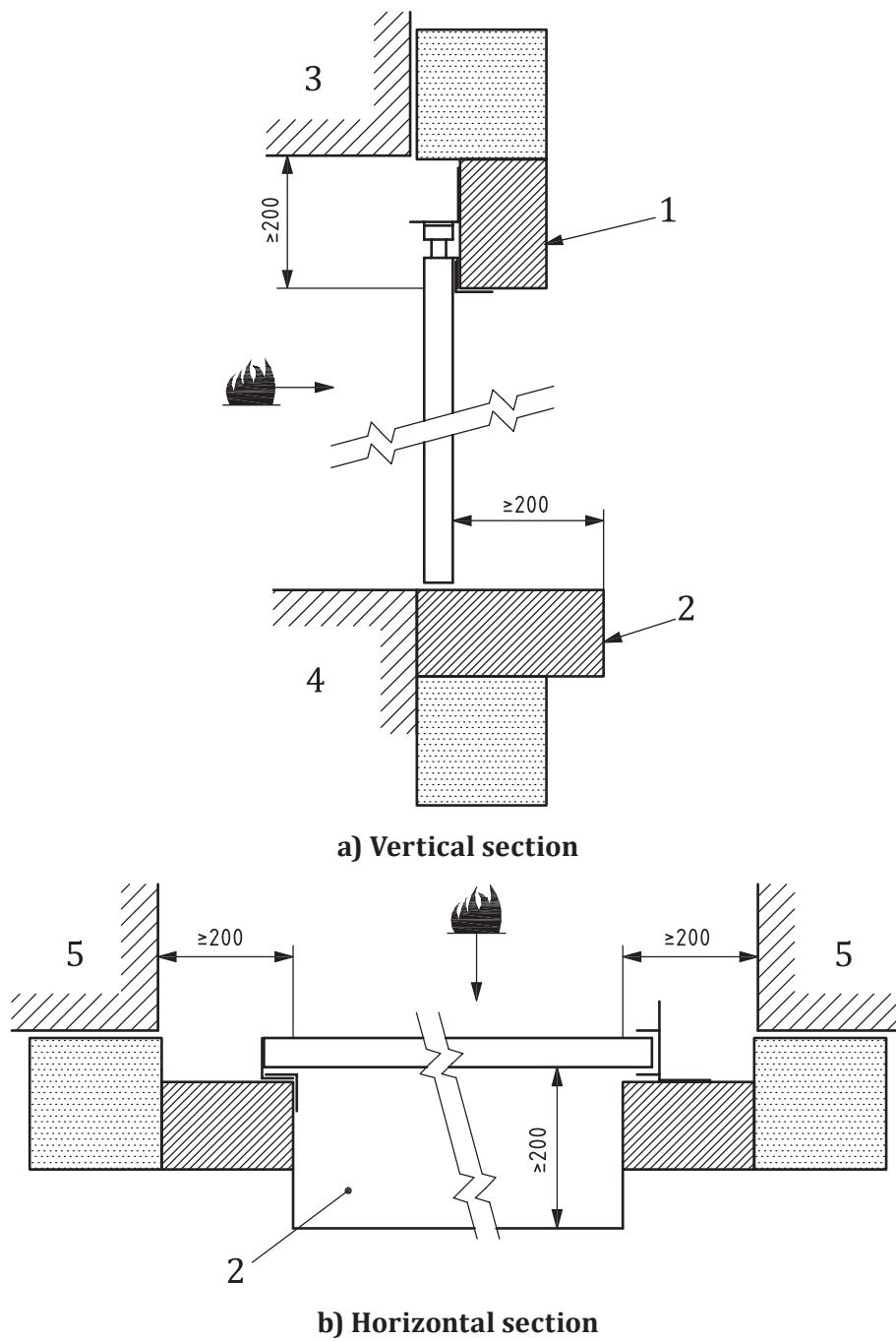

Figure 5 — Examples for mounting hinged door specimens (vertical sections)



Key

- 1 supporting construction
- 2 floor, rigid non-combustible material
- 3 top of furnace
- 4 bottom of furnace
- 5 side of furnace

Figure 6 — Example of details for mounting sliding door specimens

Dimensions in millimetres

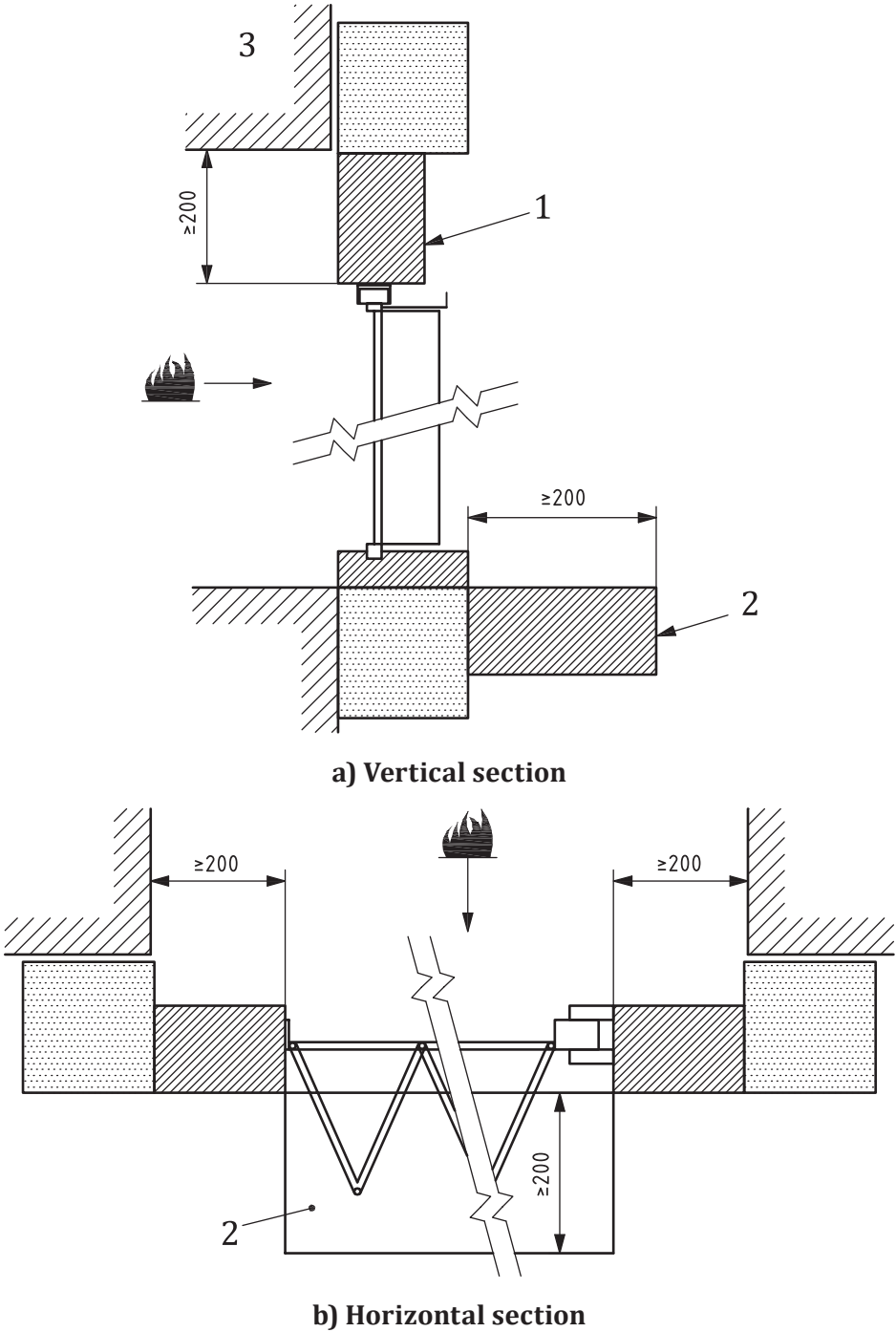

- Key**
- 1 supporting construction
 - 2 floor, rigid non-combustible material
 - 3 top of furnace

Figure 7 — Example of details for mounting folding door specimens

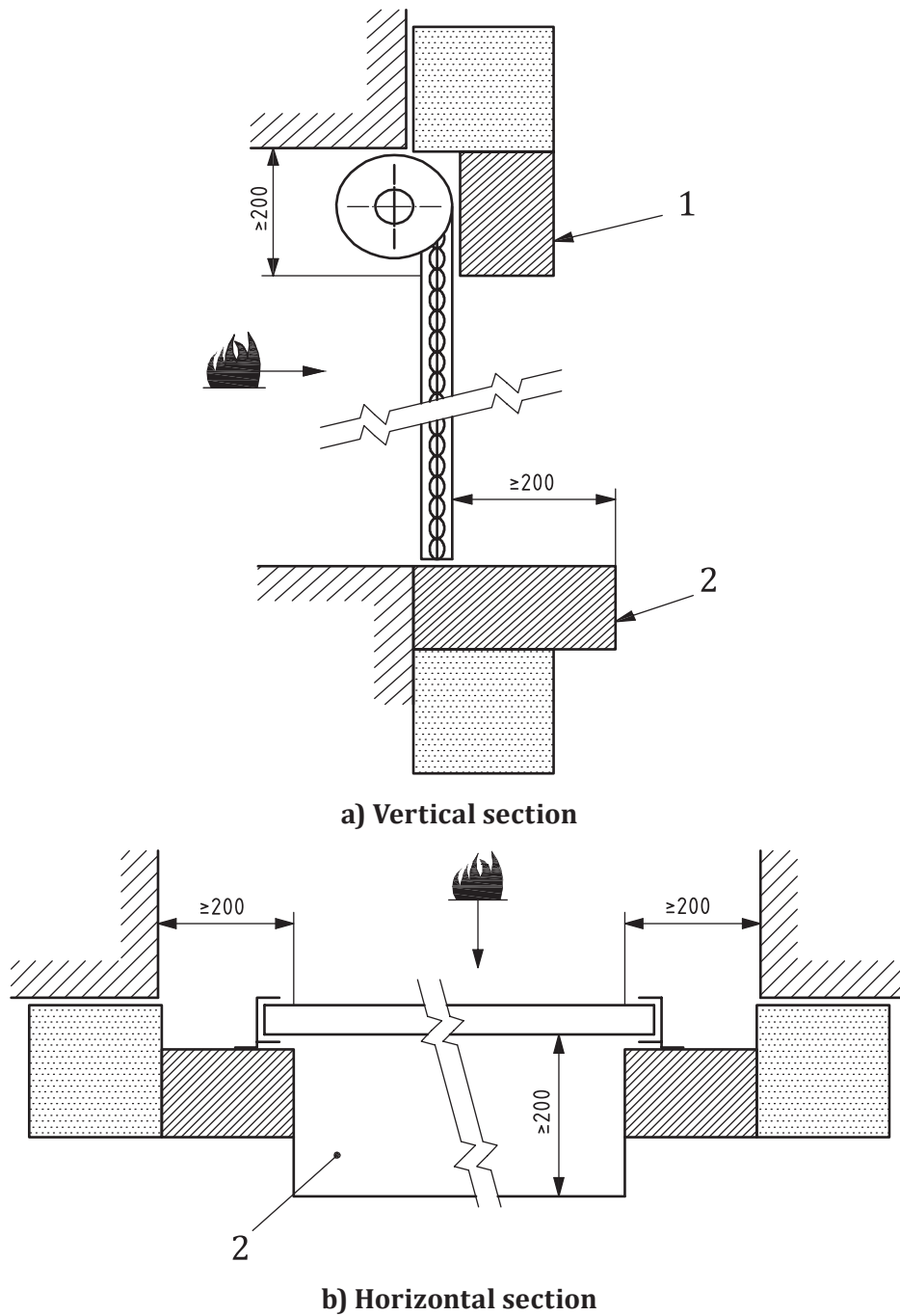

Key

- 1 supporting construction
- 2 floor, rigid non-combustible material

Figure 8 — Example of details for mounting rolling-shutter specimens

7.3.4 Restraint on supporting construction

7.3.4.1 For flexible standard supporting constructions and all associated supporting constructions, the partition or wall shall be erected so that it can distort freely perpendicular to the plane of the construction along the vertical edges, i.e. there shall be a free edge at each end of the construction.

7.3.4.2 For rigid standard supporting constructions, the wall shall be erected with no freedom to distort perpendicular to the plane of the wall along the vertical edges, i.e. it shall be fixed to the inside of the test frame as in normal practice.

7.3.4.3 If the bottom of the test specimen is at floor level in practice, then, at the bottom of the aperture, continuity of the floor shall be simulated using a solid, non-combustible rigid material that has a minimum width of 200 mm on each side of the assembly, i.e. from the exposed to the unexposed face. The furnace floor can be regarded as part of the simulation of the floor continuity provided that it is level with the base of the assembly. If a cill detail is incorporated as part of the door or shutter assembly, this shall be incorporated within, or placed on top of, the extension. If the test specimen is not to be used at floor level, and provided that it has a frame detail to all four sides of the aperture, then it may be mounted simply within the thickness of the wall, without the extension.

If the specimen is tested in conjunction with a non-combustible floor, then this might not represent the situation when the specimen is installed above a combustible flooring such as timber or carpet.

7.4 Gaps

7.4.1 The adjustment of the door leaf, leaves or shutter and gaps shall be within the tolerances of the design values stipulated by the sponsor. These shall be representative of those used as intended for use in practice, so that appropriate clearances exist, e.g. between the fixed and moveable components.

7.4.2 In order to generate the widest field of direct application, the gaps shall be set between the middle value and the maximum value within the range of gaps given by the sponsor.

NOTE A door or shutter assembly with a specified range of gaps from 3 mm to 8 mm is tested with gaps set between 5,5 mm and 8 mm.

Examples of gap measurement are given in [Figures 9](#) to [12](#).

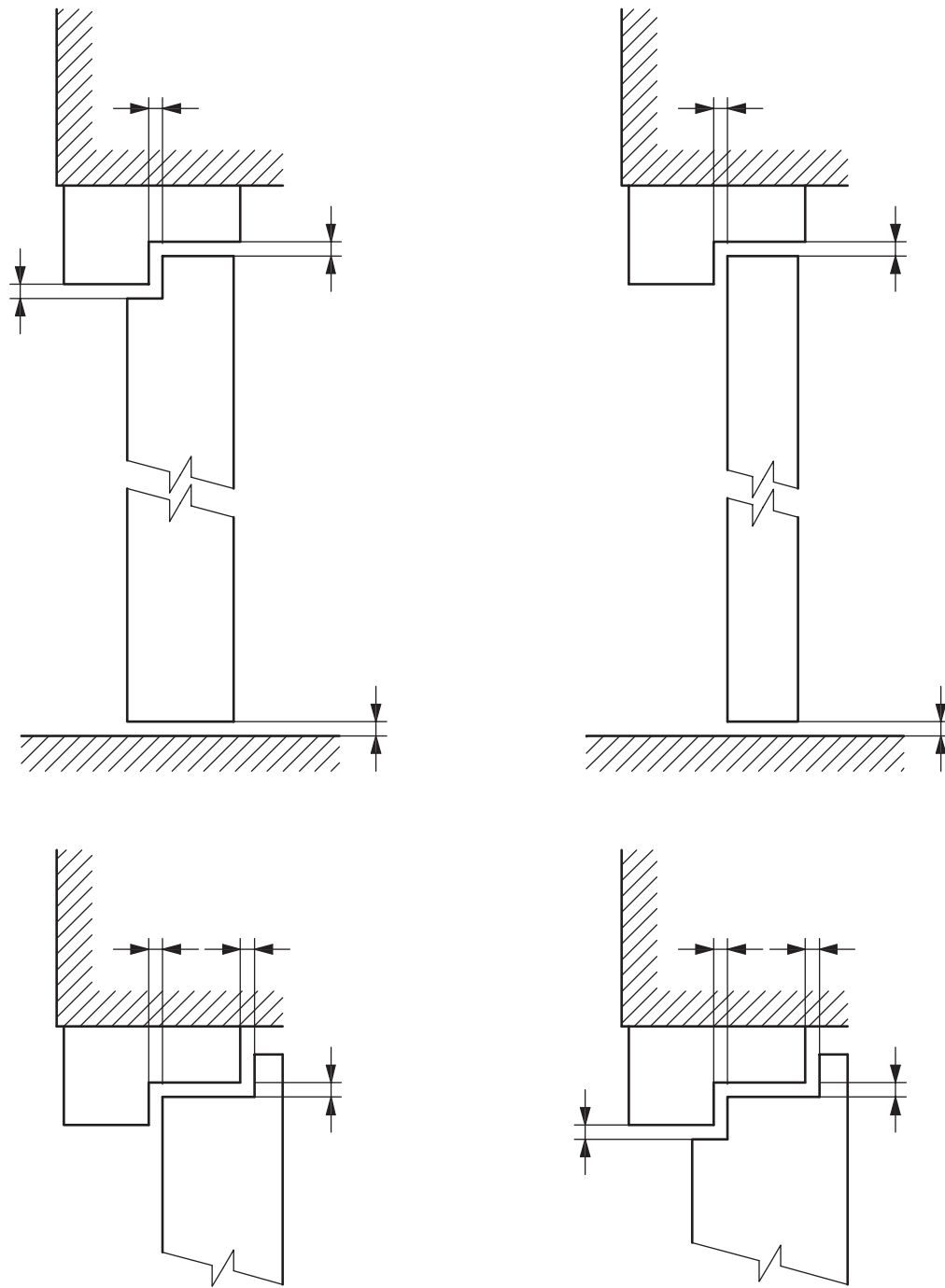
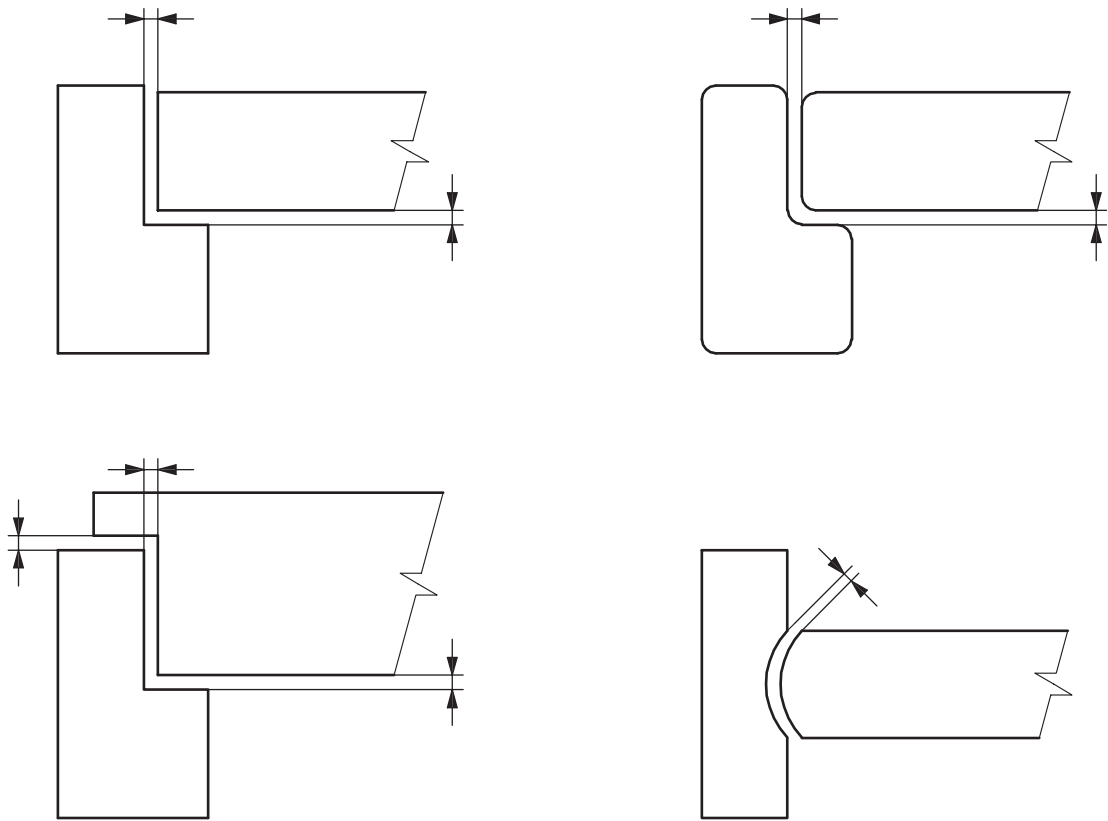
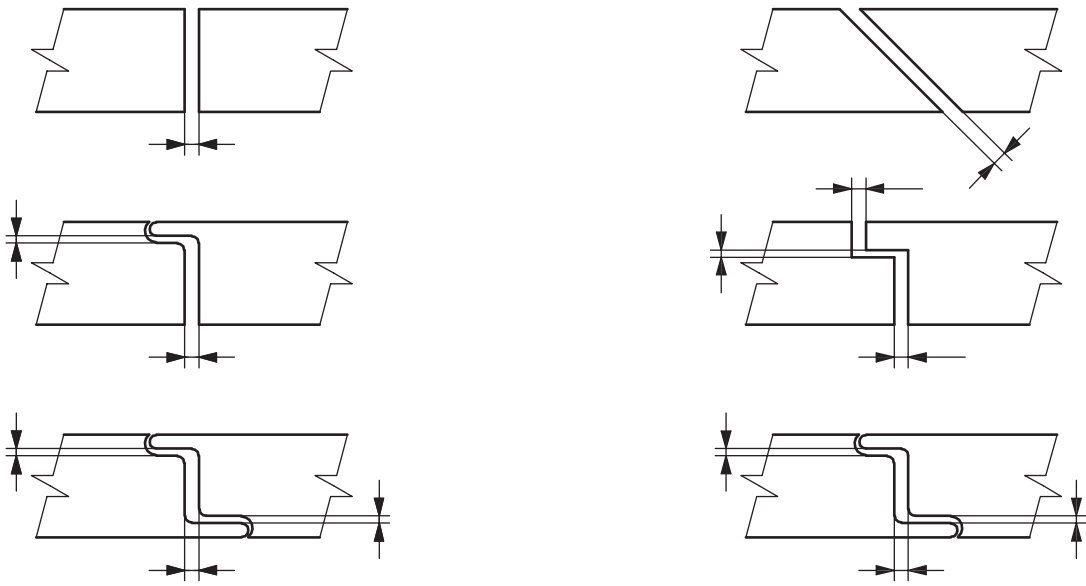

Figure 9 — Examples of clearance gap measurements for hinged and pivoted doors — Vertical sections



a) Single doors



b) Meeting edge for double doors

Figure 10 — Examples of gap measurements for hinged and pivoted doors

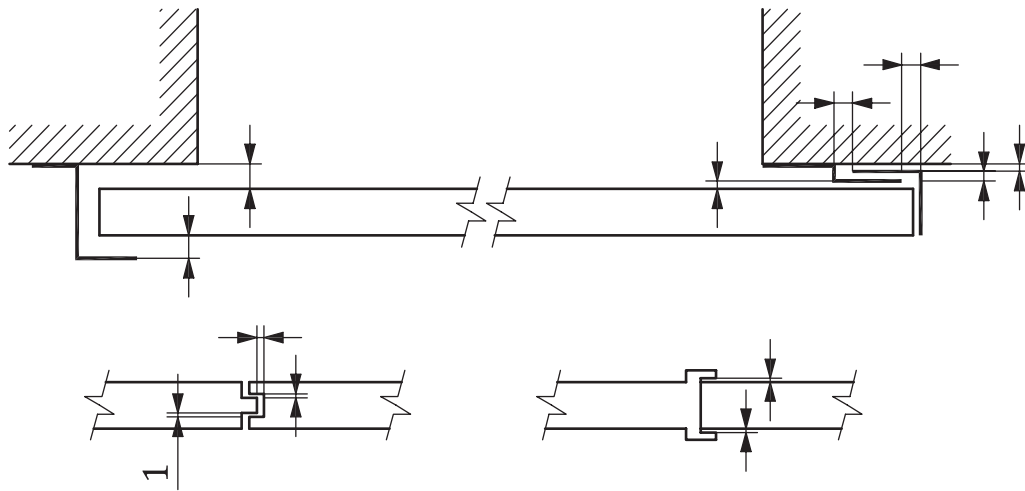

a) Single doors

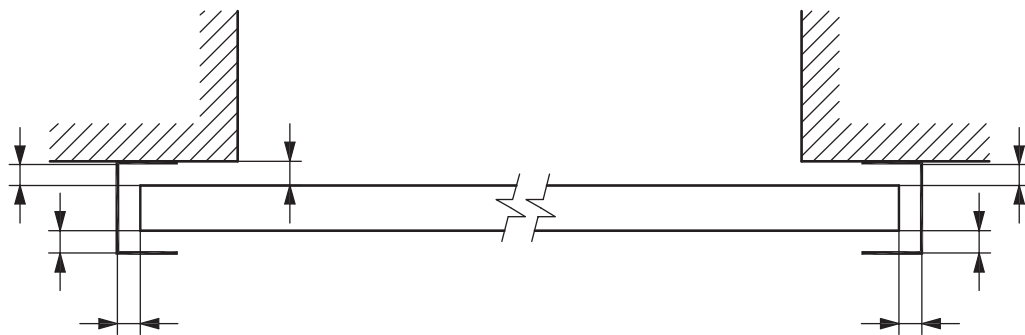

b) Roller shutters

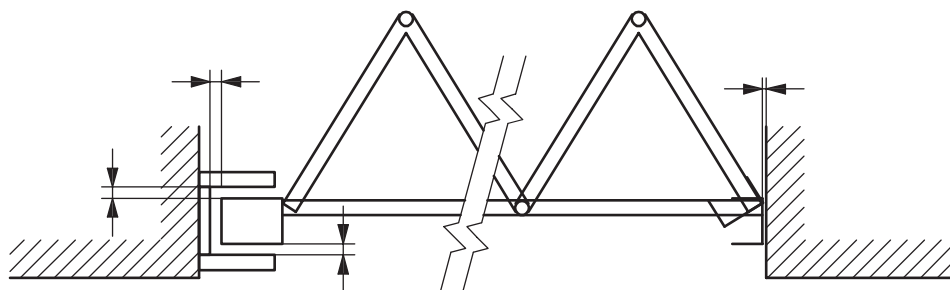

c) Sliding folding doors

Key

1 junction between two leaves

Figure 11 — Examples of gap measurements — Horizontal sections

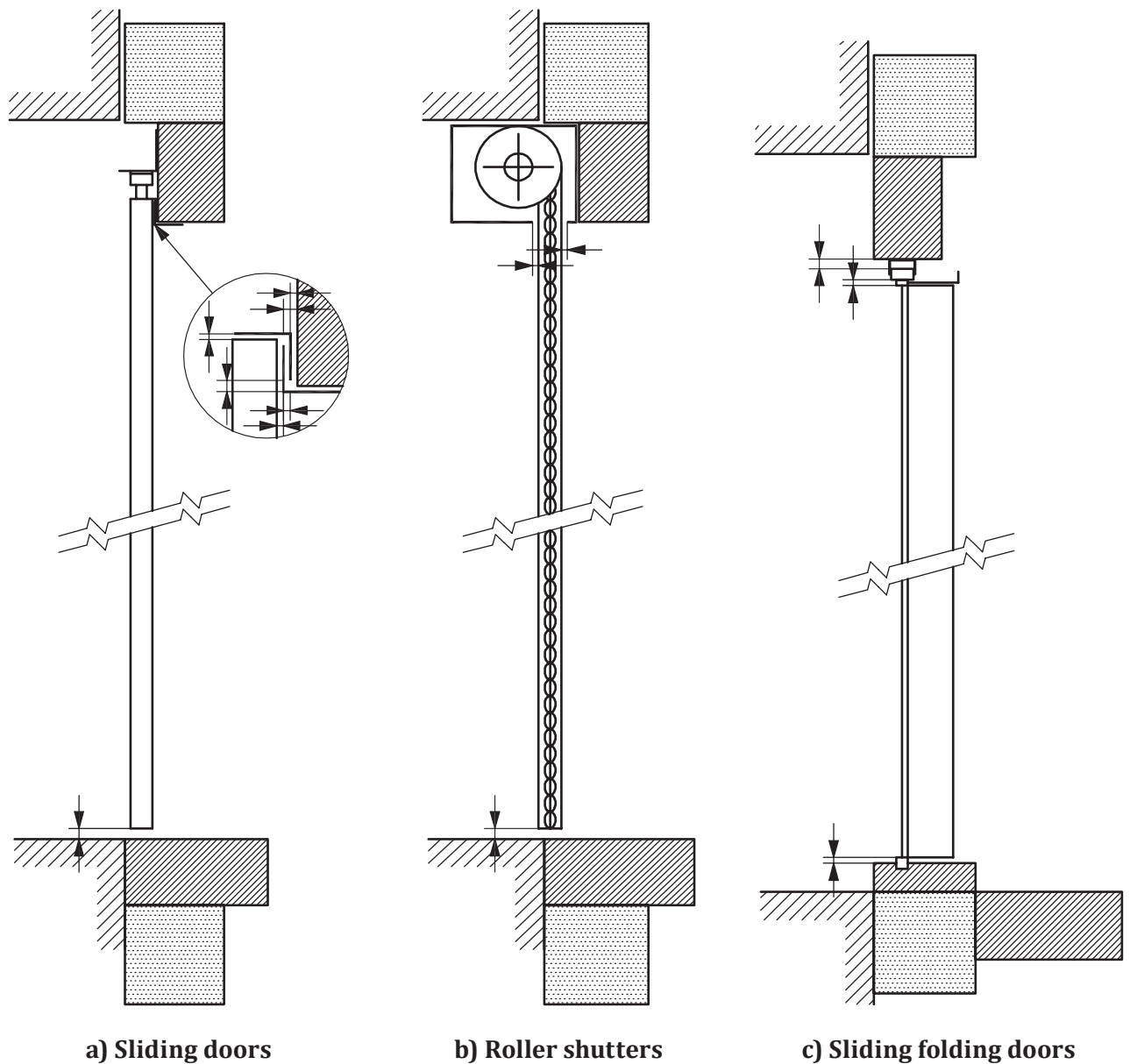

Figure 12 — Examples of gap measurements — Vertical sections

8 Conditioning

8.1 Moisture content

The test specimen shall be conditioned in accordance with ISO 834-1. Requirements for conditioning of supporting constructions are given in [Annex A](#).

8.2 Mechanical

Some product standards exist for certification purposes that require mechanical testing before the start of the fire test. Durability requirements are given in the relevant product standard. Where a relevant product standard does not exist, the following preconditioning shall be performed before the start of the fire test exposure:

The testing laboratory shall be satisfied that the door leaf, panel or shutter curtain operates satisfactorily. A series of 50 opening/closing cycles of at least 75° for side-hung doorsets and at least 300 mm for sliding doorsets and shutters shall precede the fire test.

9 Application of instrumentation

9.1 Temperature measurements

9.1.1 Furnace-temperature measuring instrument

Plate thermometers shall be provided in accordance with ISO 834-1. They shall be evenly distributed over a vertical plane 100 mm from the nearest plane of the test construction; see [Figure 13](#). There shall be at least one plate thermometer for every 1,5 m² of the exposed surface area of the test construction, subject to a minimum of four. The plate thermometer shall be oriented so that “side A” faces the back wall of the furnace.

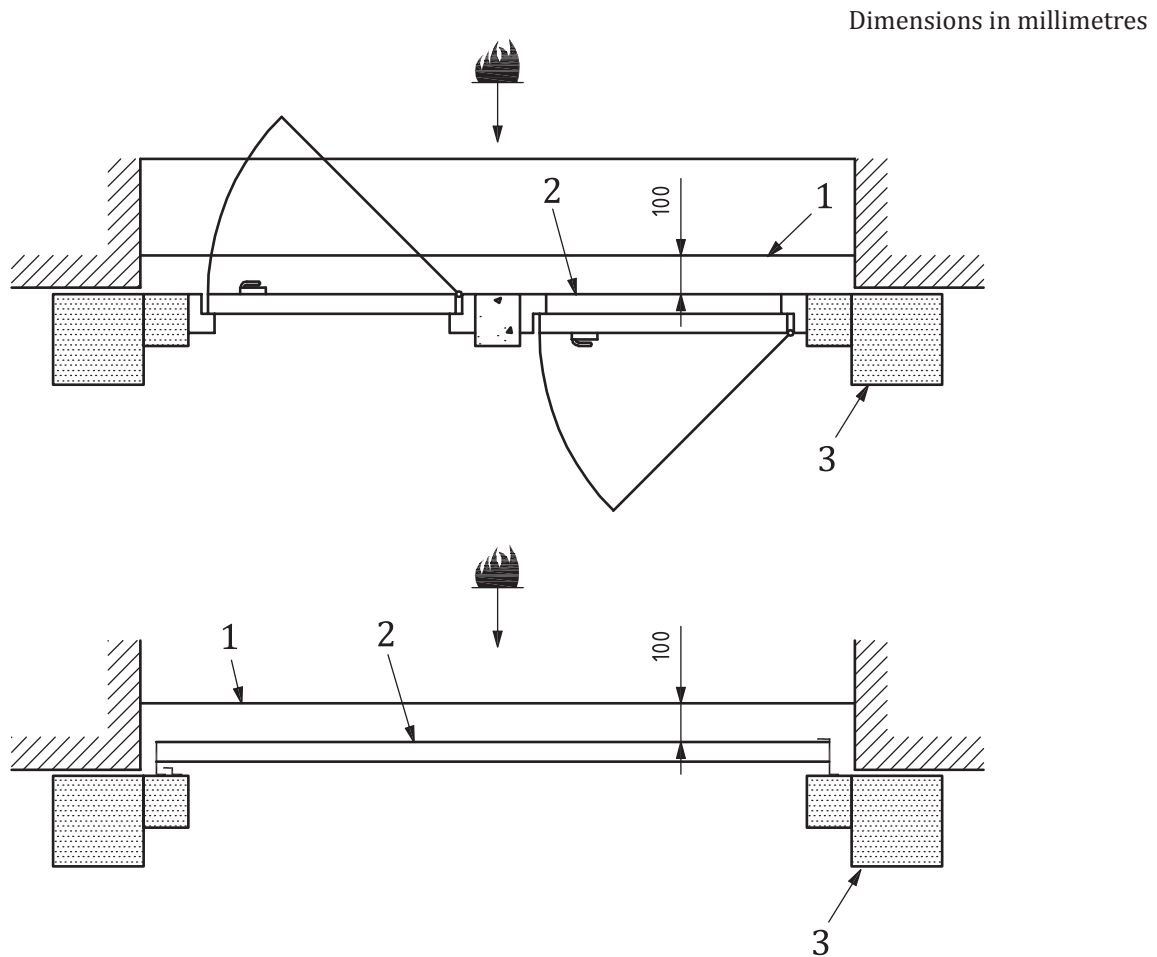

Key

- 1 plane of furnace
- 2 nearest plane of test construction
- 3 test frame

Figure 13 — Example of positions of furnace-temperature measuring devices (plate thermometer) — Horizontal section

9.1.2 Unexposed-face thermocouples

9.1.2.1 Where no evaluation against the insulation criteria is required of the door or shutter assembly, or any part thereof, no temperature measurements are required.

9.1.2.2 Where it is required to evaluate compliance with the insulation criteria, thermocouples of the type specified in ISO 834-1 shall be attached to the unexposed face for the purpose of obtaining the average and maximum surface temperatures. Where it is not possible to apply disc thermocouples as specified in ISO 834-1 to the unexposed surface of the test specimen, due to the size or shape of the specimen, such as when testing air transfer grilles, an alternate thermocouple and pad shall be used as described in [4.3](#). Examples of the location of unexposed-face thermocouples are shown in [Figures 14 to 27](#).

Dimensions in millimetres

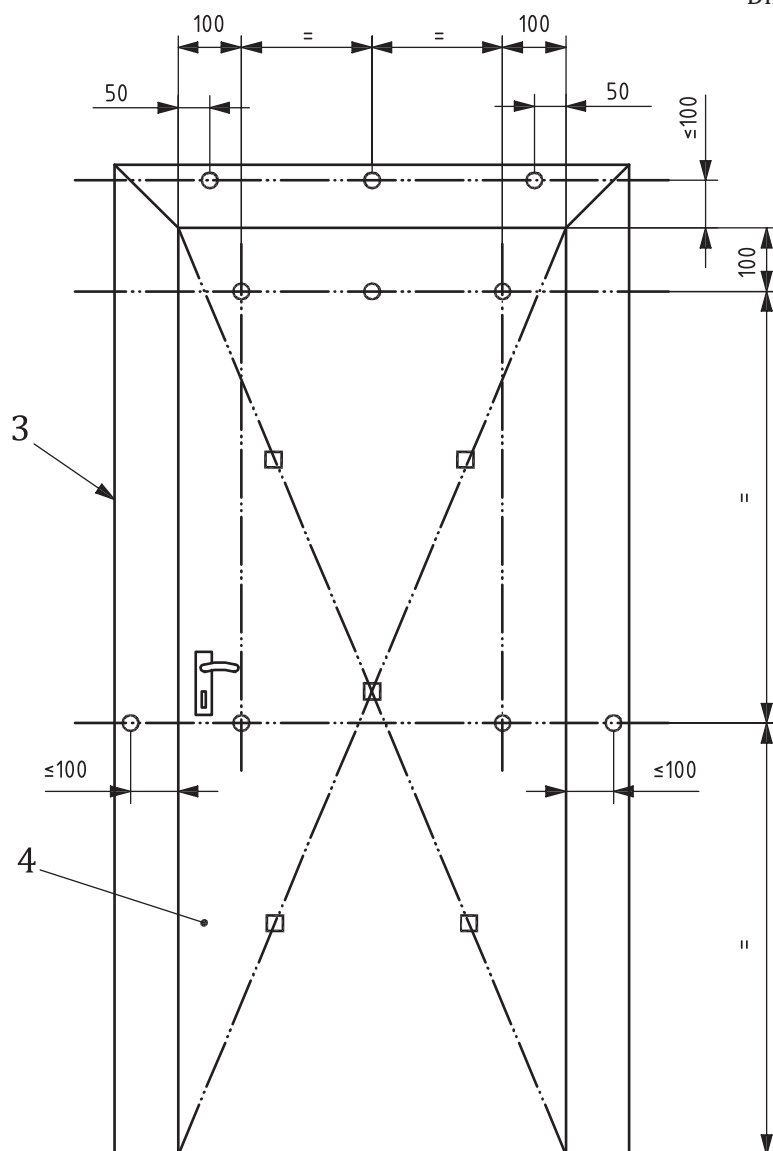

Key

- thermocouple for maximum temperature rise
- ◻ thermocouple for average temperature rise
- 3 door frame
- 4 door leaf

**Figure 14 — Example of locations of unexposed-face thermocouples —
 General arrangement — Single-leaf door, 1 200 mm**

Dimensions in millimetres

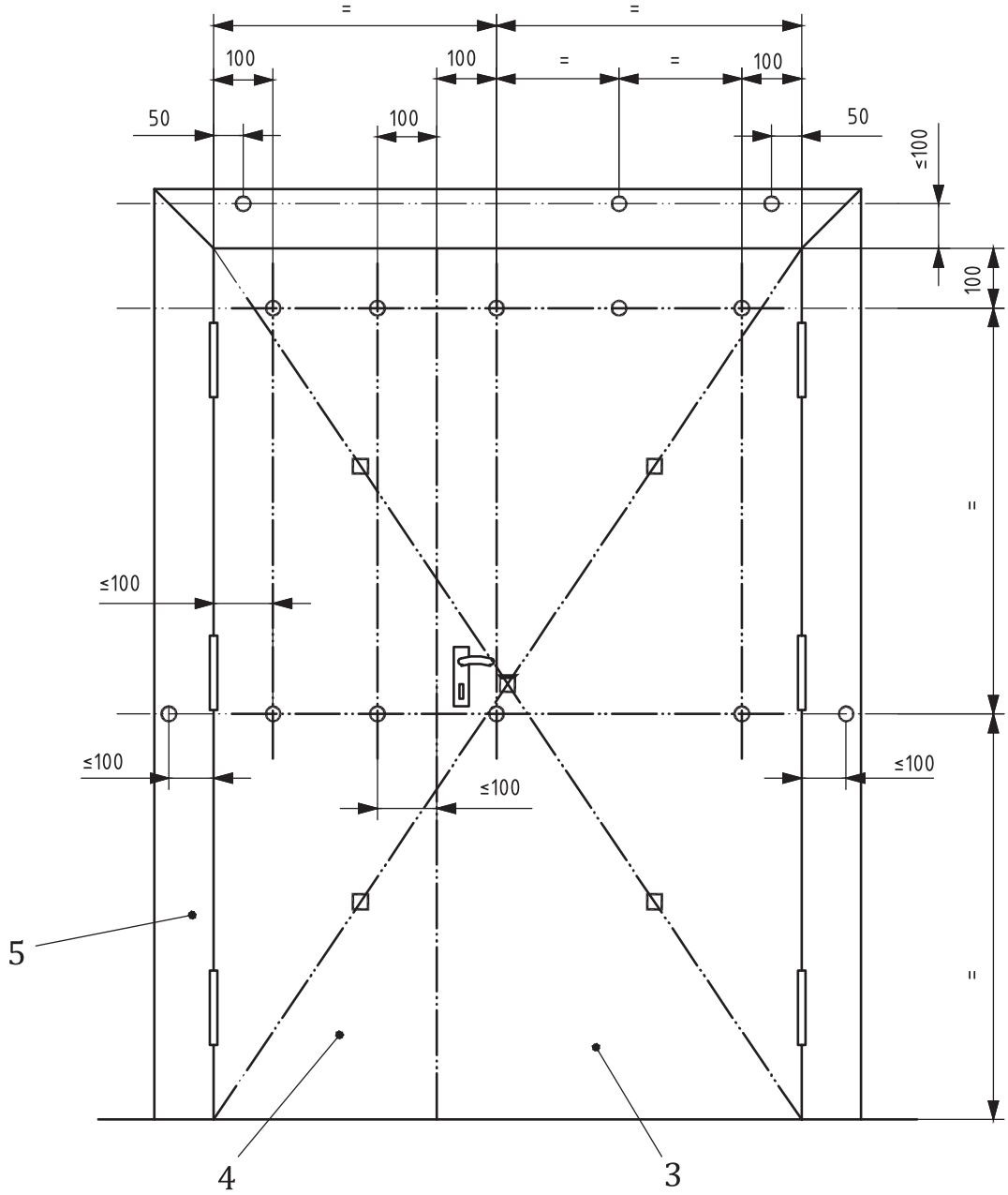

- Key**
- thermocouples for maximum temperature rise
 - thermocouples for average temperature rise
 - 3 primary door leaf
 - 4 secondary door leaf
 - 5 door frame

Figure 15 — Example of locations of unexposed-face thermocouples — General arrangement — Double-leaf door assembly: primary leaf, 1 200 mm wide; secondary leaf, <1 200 mm

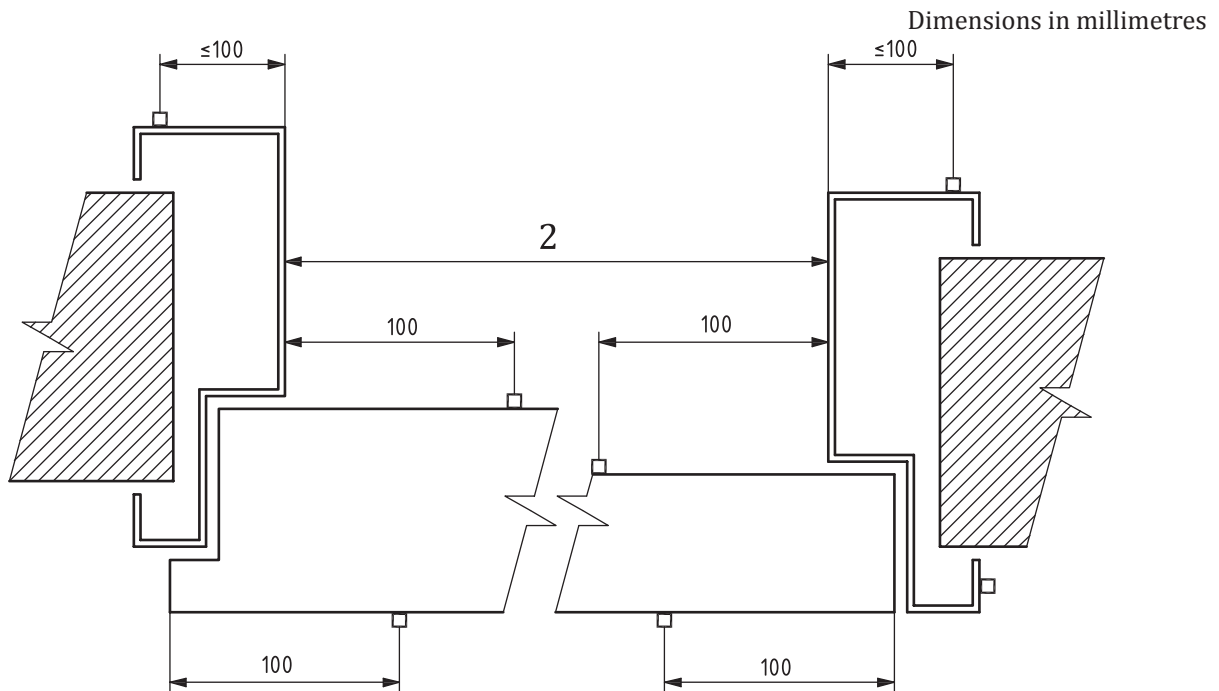

Key

- thermocouples for maximum temperature rise
- 2 clear opening

NOTE Although thermocouples are shown on both sides of the door face in this illustration to show proximity to the frame, they are placed only on the non-fire-exposed face.

Figure 16 — Example of locations of unexposed-face thermocouples at periphery of hinged and pivoted doors (detail)

Dimensions in millimetres

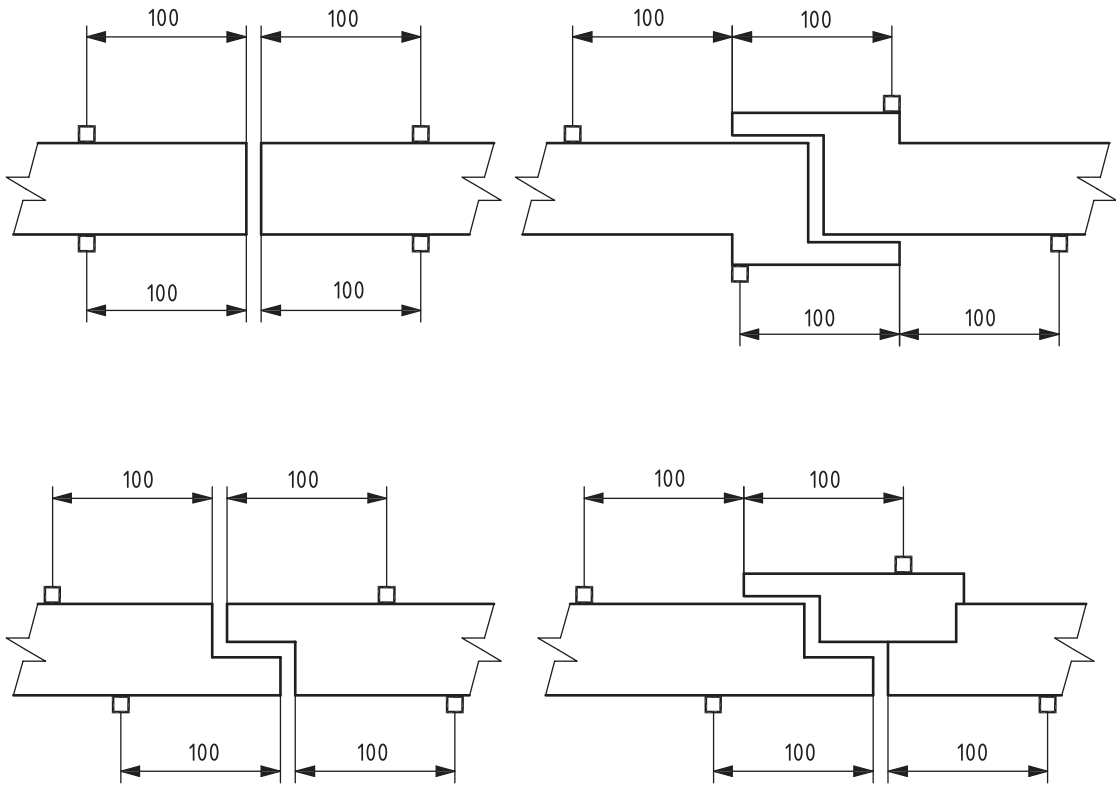

Key

- thermocouples for maximum temperature rise

NOTE Although thermocouples are shown on both sides of the door face in this illustration to show proximity to the meeting edge, they are placed only on the non-fire-exposed face.

Figure 17 — Example of location of unexposed-face thermocouples on meeting edges — Hinged or pivoted double-leaf doors

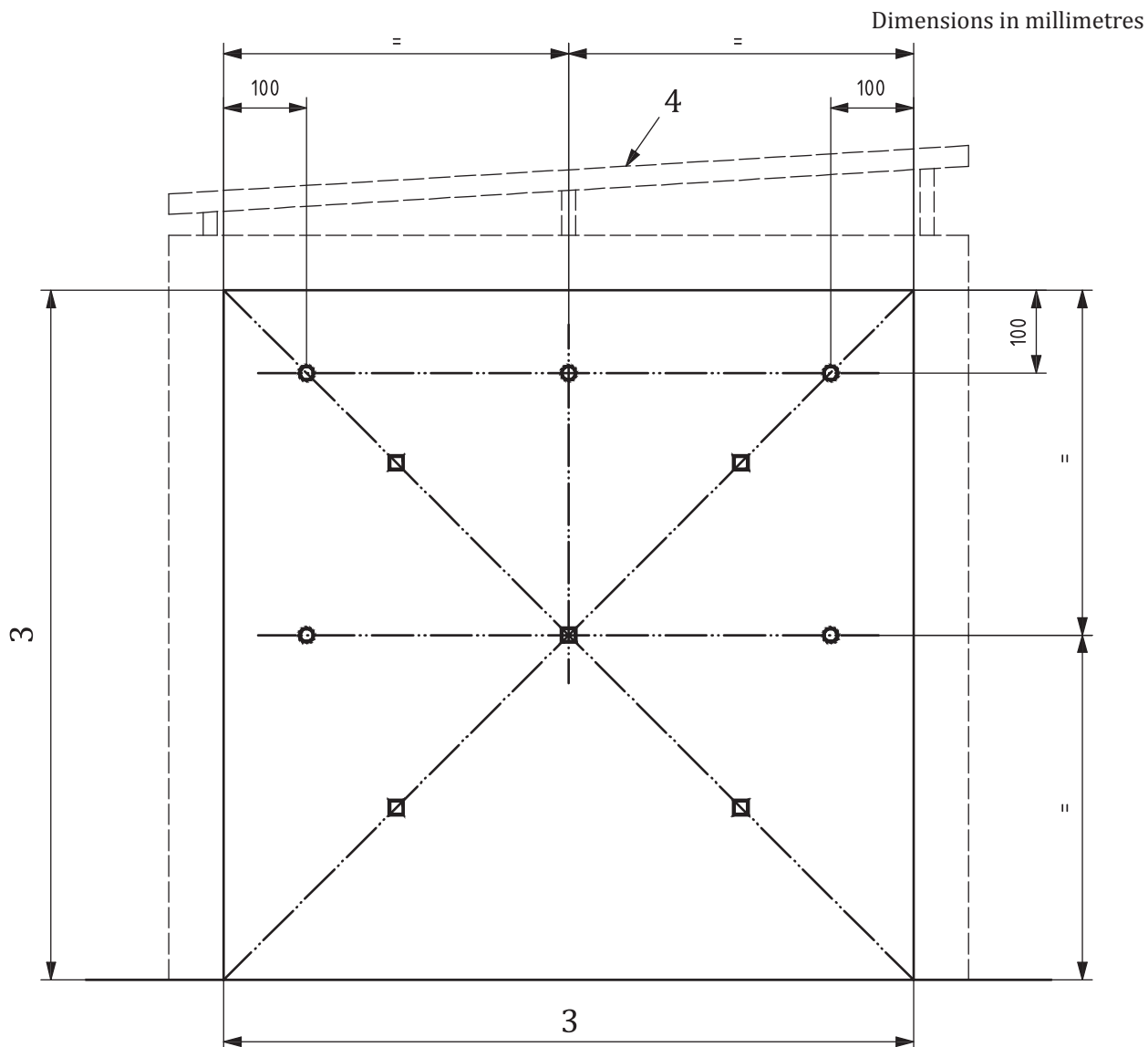

Key

- thermocouples for maximum temperature rise
- thermocouples for average temperature rise
- 3 clear opening
- 4 door track

**Figure 18 — Example of locations of unexposed-face thermocouples —
Single-leaf sliding door**

Dimensions in millimetres

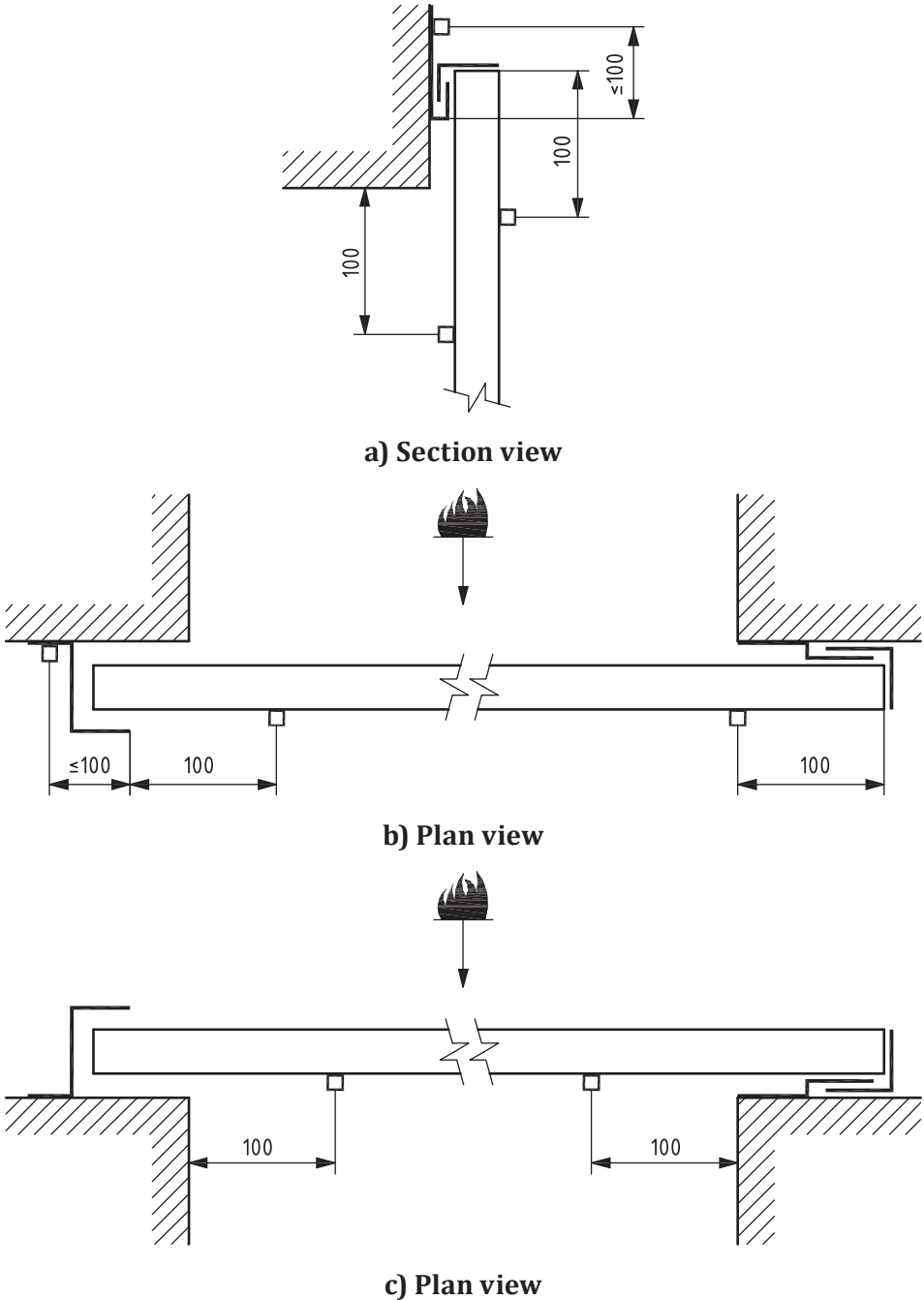

Key

- thermocouples for maximum temperature rise

NOTE Although thermocouples are shown on both sides of the door face in this illustration to show proximity to the frame, they are placed only on the non-fire-exposed face.

Figure 19 — Example of locations of unexposed-face thermocouples — Single-leaf sliding door

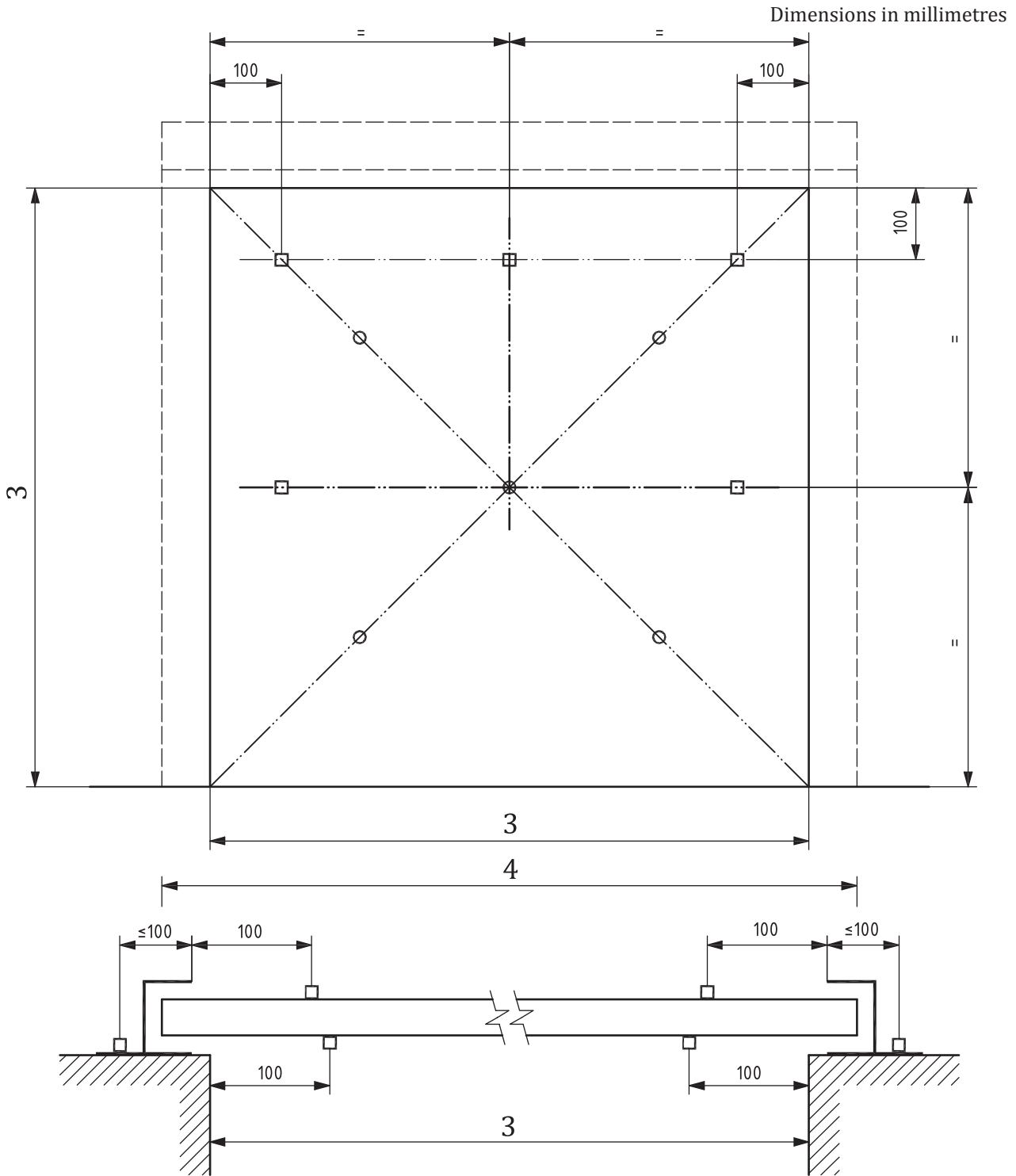

Key

- thermocouples for maximum temperature rise
- thermocouples for average temperature rise
- 3 clear opening
- 4 shutter curtain

NOTE Although thermocouples are shown on both sides of the door face in this illustration to show proximity to the frame, they are placed only on the non-fire-exposed face.

Figure 20 — Example of locations of unexposed-face thermocouples, general arrangement — Roller shutter

Dimensions in millimetres

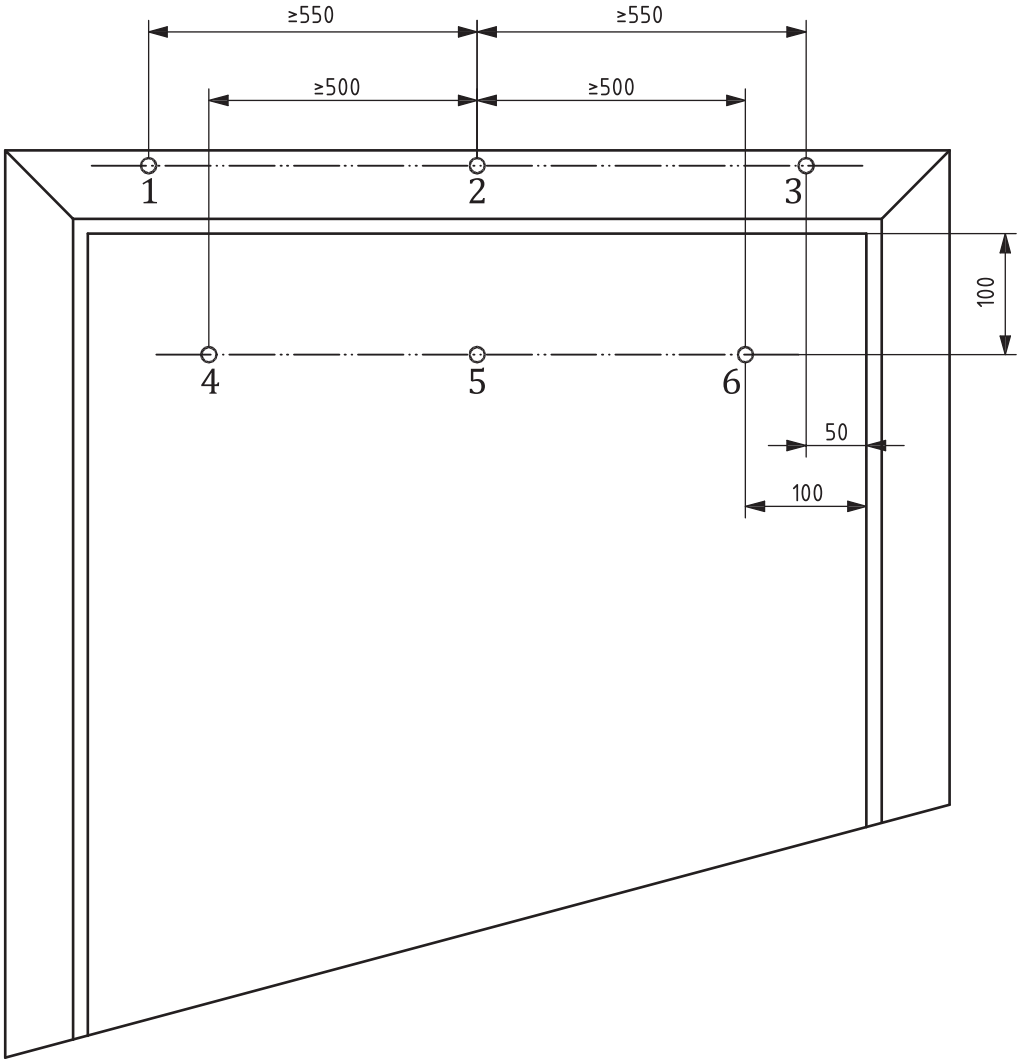

Key

1 to 6 thermocouples for maximum temperature rise

Thermocouples 1, 3, 4 and 6 are always required. Thermocouples 2 and 5 are not required if the leaf width is less than 1 200 mm.

Figure 21 — Reduction in number of unexposed-face thermocouples with decreasing leaf width

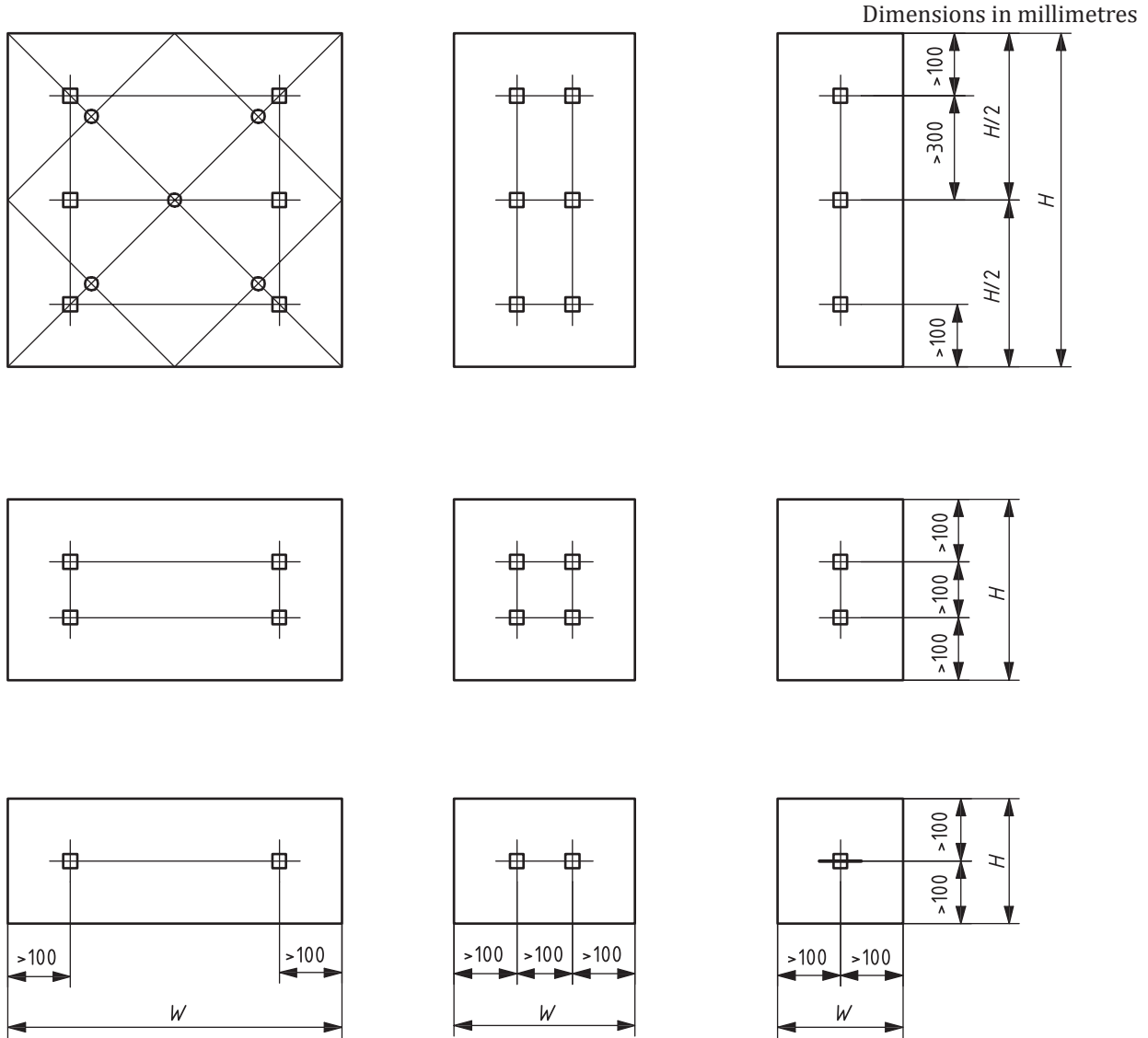

- Key**
- thermocouples for maximum temperature rise
 - thermocouples for average temperature rise
 - W width of panel
 - H height of panel

Figure 22 — Examples of locations of thermocouples in discrete areas, e.g. side panels, over panels and transom panels, assuming that there is only one of each type in the specimen

Dimensions in millimetres

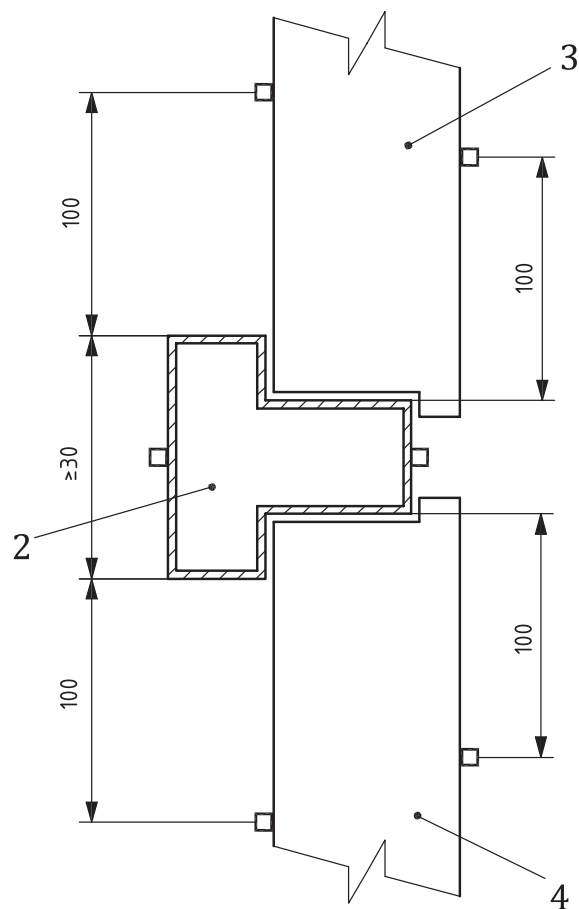

Key

- thermocouples for maximum temperature rise
- 2 transom frame width for application of thermocouples
- 3 transom panel
- 4 door leaf

NOTE 1 Although thermocouples are shown on both sides of the door face in this illustration to show proximity to the frame, they are placed only on the non-fire-exposed face.

NOTE 2 See 9.3 for additional guidance on single doors.

**Figure 25 — Example of locations of thermocouples on an unexposed face —
Example for double-leaf door with transom panel (largest leaf width <1 200 mm)**

Dimensions in millimetres

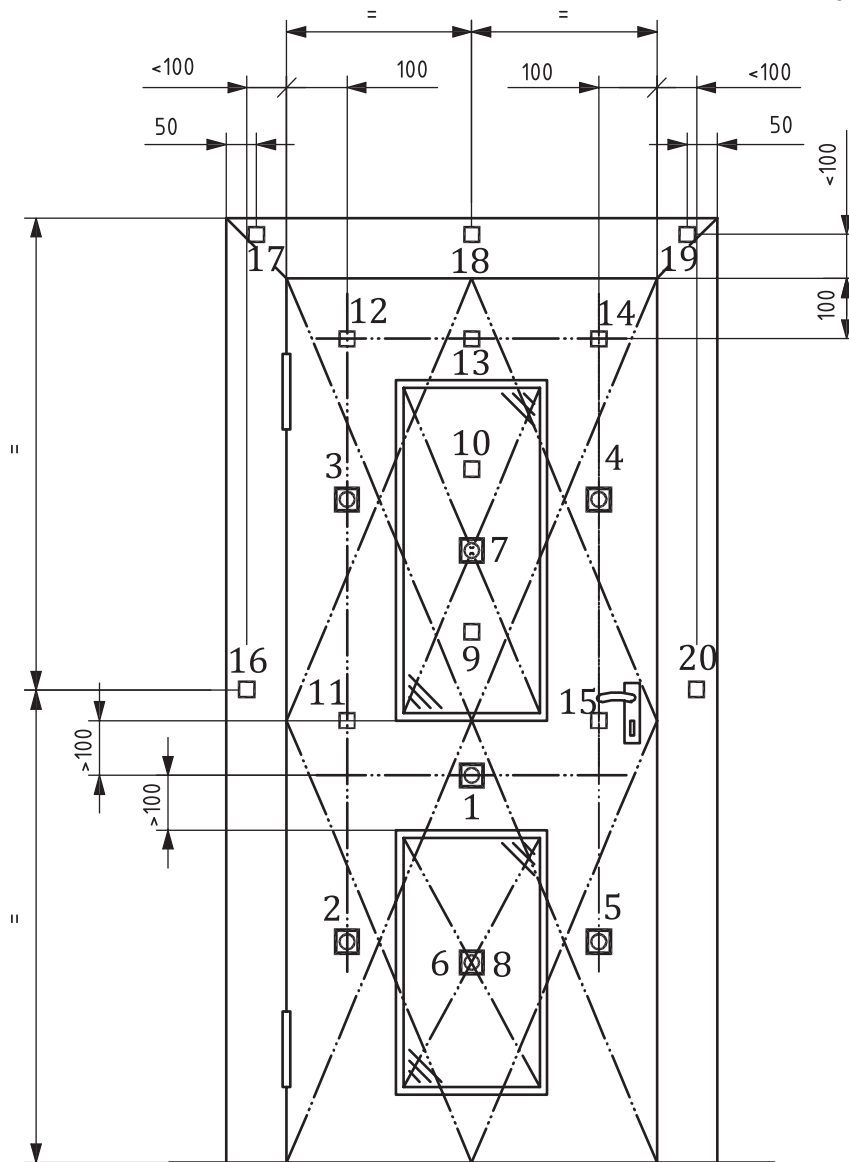

Key

- thermocouples 9 to 20 for maximum temperature rise
- ⊗ thermocouples 1 to 8 for both average and maximum temperature rise

- NOTE 1 Average temperature of glazed area is the average of thermocouples 6 and 7.
- NOTE 2 Maximum temperature of glazed area is the maximum of thermocouples 6 to 10.
- NOTE 3 Average temperature of door leaf is the average of thermocouples 1 to 5.
- NOTE 4 Maximum temperature of door leaf is the maximum of thermocouples 1 to 5 and 11 to 20.

Figure 26 — Example of locations of unexposed-surface thermocouples on hinged door incorporating glazing (width of door leaf >1 200 mm)

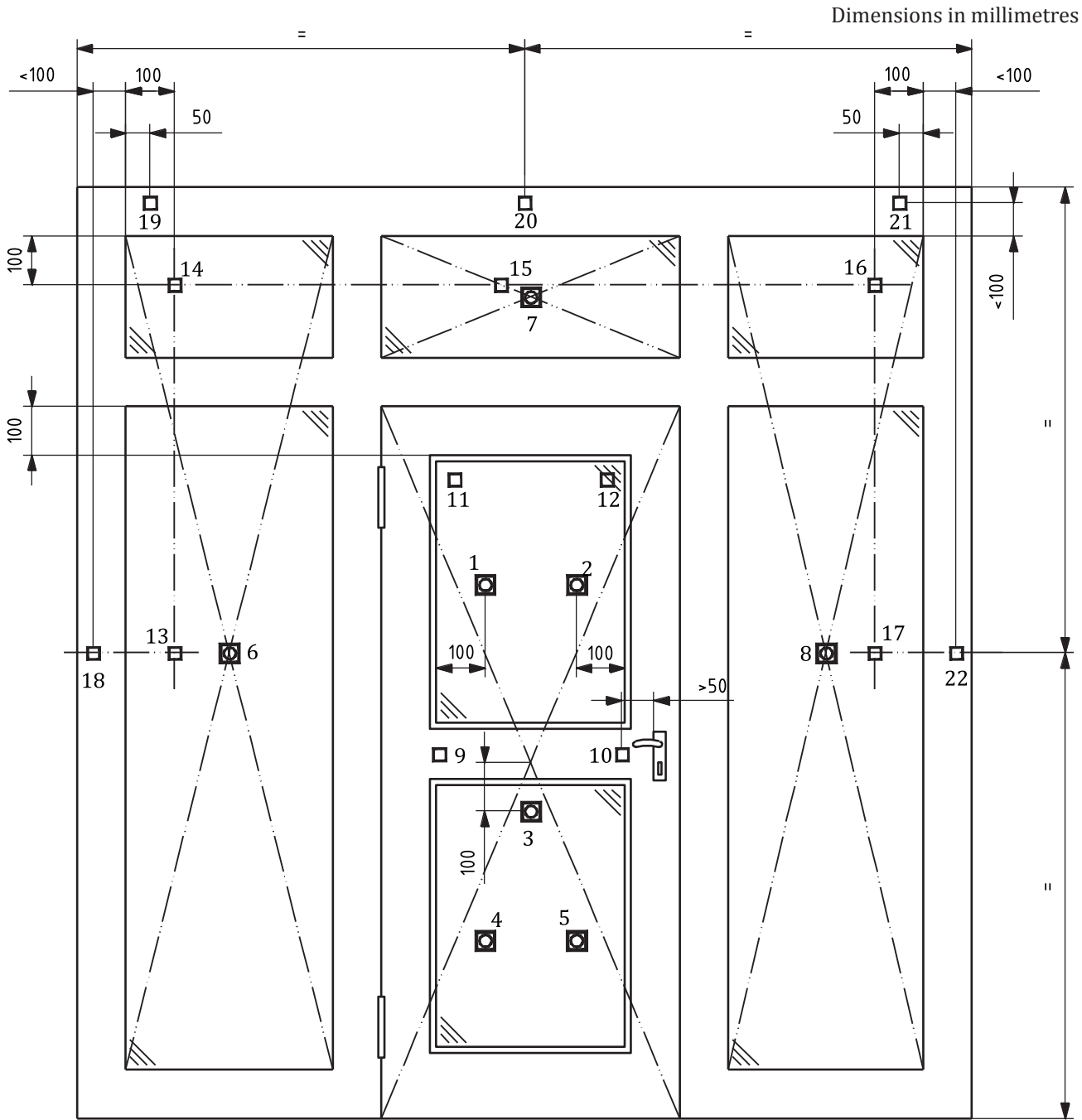

Key

- thermocouples 9 to 22 for maximum temperature rise
- ⊗ thermocouples 1 to 8 for both average and maximum temperature rise

- NOTE 1 Average temperature of door leaf is the average of thermocouples 1 to 5.
- NOTE 2 Maximum temperature of door leaf is the maximum of thermocouples 1 to 5 and 9 to 12.
- NOTE 3 Average temperature of side/over panels is the average of thermocouples 6 to 8.
- NOTE 4 Maximum temperature of side/over panels is the maximum of thermocouples 6 to 8 and 13 to 22.

Figure 27 — Example of locations of unexposed-surface thermocouples on door assemblies with multiple side/over panels

9.1.2.3 The temperature of the supporting construction in which the door or shutter assembly is mounted is not required to be measured and, therefore, no thermocouples are required.

9.1.2.4 No thermocouple shall be placed within 50 mm of any hardware.

9.1.2.5 Position five thermocouples (for single- or double-leaf doors), one at the centre of each of the specimen leaves (single or multiple) and one at the centre of each quarter section. These shall not be located closer than 50 mm to any joint, stiffener or through component, nor closer than 100 mm to the edge of the leaf.

9.1.2.6 For door or shutter assemblies which incorporate discrete areas of different thermal insulation $W \geq 0,1 \text{ m}^2$ (e.g. flush over panels, transom panels, side panels or glazed panels within a door leaf), extra thermocouples shall be evenly distributed over the sum of the surface of those areas to determine the average temperature at a density of one thermocouple per square metre or part thereof, subject to a minimum of two. The average insulation performance of the sum of each area shall be determined.

9.1.2.7 **Except for door or shutter assemblies with air transfer grilles**, when the total area of a single portion of the door or shutter assembly represents less than $0,1 \text{ m}^2$, it shall be disregarded for the purpose of ascertaining the average unexposed-face temperature.

9.1.2.8 For door or shutter assemblies which incorporate air transfer grilles the average and maximum unexposed face temperature shall be determined as follows:

The thermocouples to determine average unexposed-face temperatures shall be fixed onto the air transfer grille at a density depending on the grille surface area, according to [Table 1](#):

Table 1 — Number of thermocouples for air transfer grilles

Surface area, m^2	Number of thermocouples
<0,04	1
$\geq 0,04 \dots < 0,10$	2
$\geq 0,10 \dots < 0,36$	3
$\geq 0,36$	5

For air transfer grilles with surface area less than $0,04 \text{ m}^2$, only one thermocouple shall be placed in the centre of the air transfer grille to determine the maximum unexposed-face temperature rise.

Two thermocouples are required for air transfer grilles with surface area equal to or greater than $0,04 \text{ m}^2$ but less than $0,10 \text{ m}^2$. Divide the air transfer grille in half with a vertical centre line. Then place one thermocouple in the centre of each half of the air transfer grille to determine the maximum unexposed-face temperature rise.

Three thermocouples are required for air transfer grilles with surface area equal to or greater than $0,10 \text{ m}^2$ but less than $0,36 \text{ m}^2$. Divide the air transfer grille in half with a vertical centre line. Then place one thermocouple in the centre of each half of the air transfer grille and one at the centre of the vertical centre line to determine the maximum unexposed-face temperature rise.

Five thermocouples are required for air transfer grilles with surface area equal to or greater than $0,36 \text{ m}^2$. Divide the air transfer grille into four quadrants with vertical and horizontal centre lines. Then place one thermocouple in the centre of each quadrant of the air transfer grille and one at the centre of the air transfer grille to determine the maximum unexposed-face temperature rise.

The thermocouples shall be located no closer than 50 mm from the edge of the air transfer grille.

9.2 Maximum temperature

9.2.1 The maximum temperature shall be determined from the five thermocouples fixed to determine the average temperature rise (as given in [9.1.2.5](#)), the roving thermocouple and from additional thermocouples fixed as indicated in [9.2.2](#) and [9.2.3](#).

9.2.2 If the door or shutter assembly incorporates discrete areas of different thermal insulation $W 0,1 \text{ m}^2$ (e.g. air transfer grilles, flush over panels, transom panels, side panels, or glazed panels within a door or shutter area) that are evaluated separately with respect to average temperature rise, then the evaluation of maximum unexposed-face temperature of those areas shall also be undertaken separately. This can require extra unexposed-surface thermocouples to be applied as given in [9.1.2.6](#), [9.1.2.7](#) and [9.1.2.8](#).

9.2.3 For the temperature of door leaf or shutter, thermocouples shall be fixed to the face of each leaf or shutter as follows:

- a) at mid-height, 100 mm in from the vertical edges as specified below;
- b) at mid-width, 100 mm down from the horizontal edge as specified below;
- c) 100 mm in from the vertical edges, 100 mm down from the horizontal edge as follows:
 - 1) the inside edges of the clear opening for
 - hinged or pivoted doors opening toward the furnace,
 - shutters or sliding doors installed on the exposed side of the supporting construction, or,
 - 2) the visible part of the edge of the door leaf for
 - hinged or pivoted doors opening away from the furnace,
 - shutters or sliding doors installed on the unexposed side of the supporting construction.

If, due to the narrow width of the leaf (leaves) or shutter(s), the thermocouples specified in b) and c) are closer than 500 mm to each other, then those specified in b) are omitted.

If the leaf is <200 mm wide (e.g. as in a multi-leaf folding shutter), then the leaves are treated as if they were one leaf with respect to application of unexposed-face thermocouples for evaluating maximum temperature rise.

Examples of the reduction in the requirement for unexposed-face thermocouples with decreasing leaf width are given in [Figure 21](#).

Additional thermocouples shall be fixed to other areas of the leaf or shutter, e.g. over any through connection or position where the temperature can be expected to be higher than the mean for the surface, subject to the limitations given in [9.2.4](#), [9.2.5](#) and [9.2.6](#). See [Figures 14 to 20](#) and [22 to 27](#).

9.2.4 For the temperature of other areas, thermocouples for determination of the maximum temperature rise of side, transom and flush over panels and discrete panels of different thermal insulation within the door leaf shall be applied as for door leaves. However, if there is more than one other area of the same type, then they shall be treated as one large area (as those for the average temperature rise are). In such cases, thermocouples shall avoid any framework adjacent to the frame leaf; see [Figures 26](#) and [27](#).

9.2.5 In addition, thermocouples shall be placed on flush over panels and transom panels above door leaves (but not discrete panels within the leaf) as follows:

- a) at mid-width, 100 mm in from the horizontal edge; and
- b) 100 mm in from the vertical edges, 100 mm in from the horizontal edges.

See [Figures 23](#) and [24](#) for examples of the above. See [Figure 22](#) for exclusion of the thermocouples on panels on the basis of size and distance between thermocouples.

9.2.6 The rules for reducing the number of thermocouples on door leaves of decreasing width shall also apply in transom panels, side panels and flush over panels.

9.2.7 For air transfer grilles, the maximum temperature shall be determined from the thermocouples fixed to determine the average unexposed-face temperature given in [9.1.2.8](#). Additional thermocouples shall be fixed to the face of the air transfer grille as follows:

- a) at mid height 100 mm in from the vertical perimeter frames;
- b) at mid width 100 mm down from the horizontal top perimeter frame;
- c) 100 mm in from the vertical perimeter frames, 100 mm down from the horizontal top perimeter frame.

If the distance between thermocouples a) and c) is less than 550 mm, the thermocouple specified in b) shall be omitted.

For air transfer grilles with surface area less than 0,1 m², the additional thermocouples in a), b) and c) are omitted.

9.3 Temperature of door frame

Thermocouples shall be fixed at each of the following positions:

- a) one at mid-height on each vertical member;
- b) one on the horizontal top member of the frame (and any transom >30 mm wide, if fitted) at mid-width (100 mm away from the door joint of a multi-leaf door on the primary leaf side);
- c) one on the horizontal top member of the frame (and any transom >30 mm wide, if fitted) 50 mm in from each corner of the leaf opening.

At each of the positions, thermocouples shall be fixed as close as possible, i.e. with the centre of the disc 15 mm from the junction between the frame and the supporting construction. Irrespective of this, the distance of these thermocouples from the inside edge of the frame shall not be greater than 100 mm. See [Figure 16](#).

For single-leaf doors, if due to the narrow width of the opening, the thermocouples specified in b) and c) are closer than 550 mm to each other, then that specified in b) is omitted; see [Figure 21](#).

9.4 Pressure measurements

9.4.1 The pressure in the furnace shall be measured by means of one of the designs of sensors shown in ISO 834-1:1999, Figure 4.

9.4.2 The pressure measuring equipment shall be capable of operating within a range of -20 Pa to +30 Pa with a tolerance of ± 2 Pa.

9.4.3 The pressure recording equipment shall be capable of recording data at 1 min intervals with a tolerance of ± 1 s.

9.4.4 The pressure sensors shall be located where they are not subjected to the direct impingement of convection currents from flames or in the path of exhaust gases. The pressure sensors shall be horizontal both in the furnace and as they exit through the furnace wall, such that the pressure is relative to the same positional height from inside to the outside of the furnace. When T-shaped pressure sensors are used, the

“T” branches shall be horizontally oriented. Any vertical section of tube to the measuring instrument shall be maintained at room temperature.

9.4.5 A minimum of three pressure sensors shall be used. One pressure sensor shall be located within 100 mm from the floor, one pressure sensor shall be located within 100 mm of two thirds the height of the door or shutter and one pressure sensor shall be located within 100 mm from the top of the door or shutter.

9.5 Heat-flux measurement

9.5.1 General

In 9.5 a method of measuring heat flux is described. The hazard presented by radiation is evaluated in the test by measuring total heat flux. However, as the convection heat transfer is negligible, the measurement is reported as heat flux in this document. It considers the measurement of heat flux in a plane parallel to, and at a distance of 1,0 m from, the unexposed face of the test specimen. It includes the concept of both an average value, measured opposite the centre of the specimen, and the maximum value, which is equal to or greater than the average value if the specimen is not a uniform radiator.

Guidance is provided on the determination of the maximum value.

There is no requirement to measure the heat flux from a surface with a temperature below 300 °C because the radiation emitted from such a surface is low (typically 6 kW/m², even with an emissivity of 1,0).

9.5.2 Apparatus

Measurements of heat flux from the unexposed surface of specimens shall be made by an instrument complying with the following specifications:

- target: The target of the instrument shall not be shielded by a window or subject to a gas purge, i.e. it shall be subject to convection as well as radiation;
- suggested range: 0 kW/m² to 50 kW/m²;
- accuracy: ±5 % of maximum in range;
- time constant (time to reach 64 % of target value): <10 s;
- view angle: 180° ± 5°.

9.5.3 Procedure

9.5.3.1 General positioning

Each heat flux meter shall be positioned 1,0 m from the unexposed surface of the test specimen.

At the start of the test the target of each heat flux meter shall be parallel (±5°) to the plane of the unexposed surface of the test specimen. The target shall be pointing towards the unexposed surface of the test specimen.

There shall be no significant radiating surfaces other than the specimen within the field of view. The heat flux meter shall not be shielded or masked so that the field of view is restricted.

9.5.3.2 Specific locations

Measurements shall be taken at the following locations:

- a) opposite the geometric centre of the specimen; this is referred to as the average heat flux level;
- b) at the point at which the maximum heat flux can be expected. Often this follows logically or can be calculated from the geometry of the specimen. If the specimen is symmetrical about its centre and a uniform radiator this will coincide with the position described in [9.5.3.2 a\)](#).

If the specimen has areas of differing insulation and/or transmission, then it can be difficult to predict the point of maximum intensity with any degree of certainty. In these cases the following procedure shall be used.

- 1) Identify all areas where it is anticipated that the temperature will exceed 300 °C and that also have an area in excess of 0,1 m². Measure the heat flux opposite the notional centre of each area.
- 2) Two or more identical adjacent parts of the specimen having the same height or width, separated by less than 0,1 m, may be treated jointly together as a single radiation surface.
- 3) If the area, or sub-area, of the specimen that is expected to remain below 300 °C is less than 10 % of the total area or sub-area under consideration, then that area, or sub-area, may be treated as a single radiating surface. This allows for breaks, such as glazing bars.

9.5.4 Measurement

Measurements taken at each location described in [9.5.3.2](#) shall be recorded throughout the test at intervals not exceeding 1 min.

NOTE [Annex B](#) provides an alternative method of estimating the energy radiated from the specimen surface to the surrounding area based on the Stefan-Boltzmann radiation law.

9.6 Deflection

9.6.1 Deflection shall be measured with appropriate instrumentation to provide a history of all significant movements (i.e. greater than 3 mm) of the test construction during the test. Components where significant movement is likely to occur are

- a) door leaf or shutter relative to the frame,
- b) frame relative to the supporting construction, and
- c) supporting construction.

9.6.2 The principle of the measurement shall be by measurement against a fixed datum. The interval between measurements shall be chosen to present a history of deflection during the test. A suitable method for determining deflection of the test construction including proposals for selection of suitable intervals between measurements is given in ISO 3009.

Measurement of deflection is a mandatory requirement although there are no performance criteria associated with it. Information relating to the relative deflection between components of the test specimen, between the test specimen and the supporting construction and of the supporting construction itself can be important in determining the extended field of application of the test result. [Figures 28 to 31](#) show suggested positions for measuring deflection.

Dimensions in millimetres

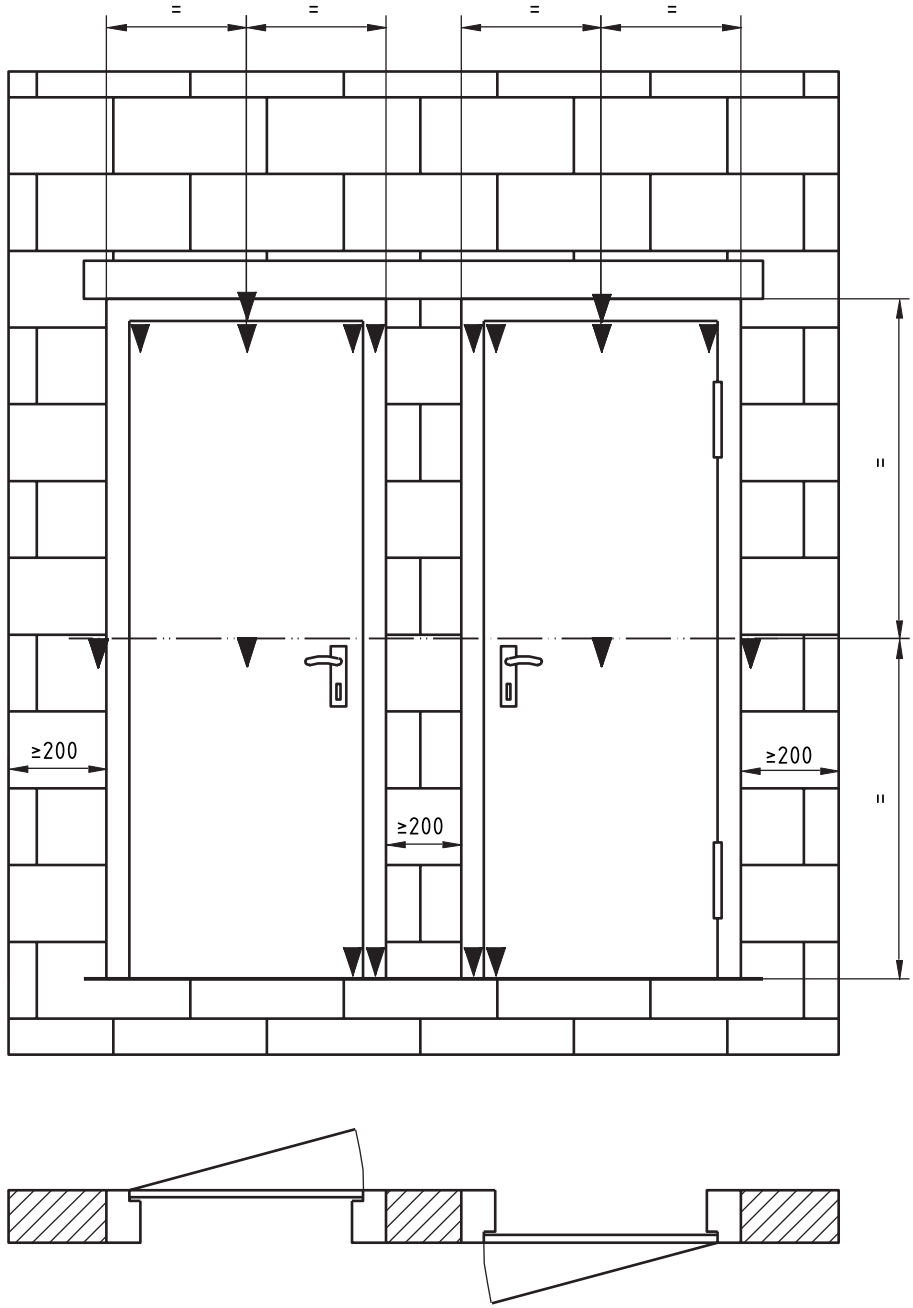

Key

▼ suggested positions for measuring deformation

Figure 28 — Suggested positions for deformation measurements — Single-leaf door assemblies

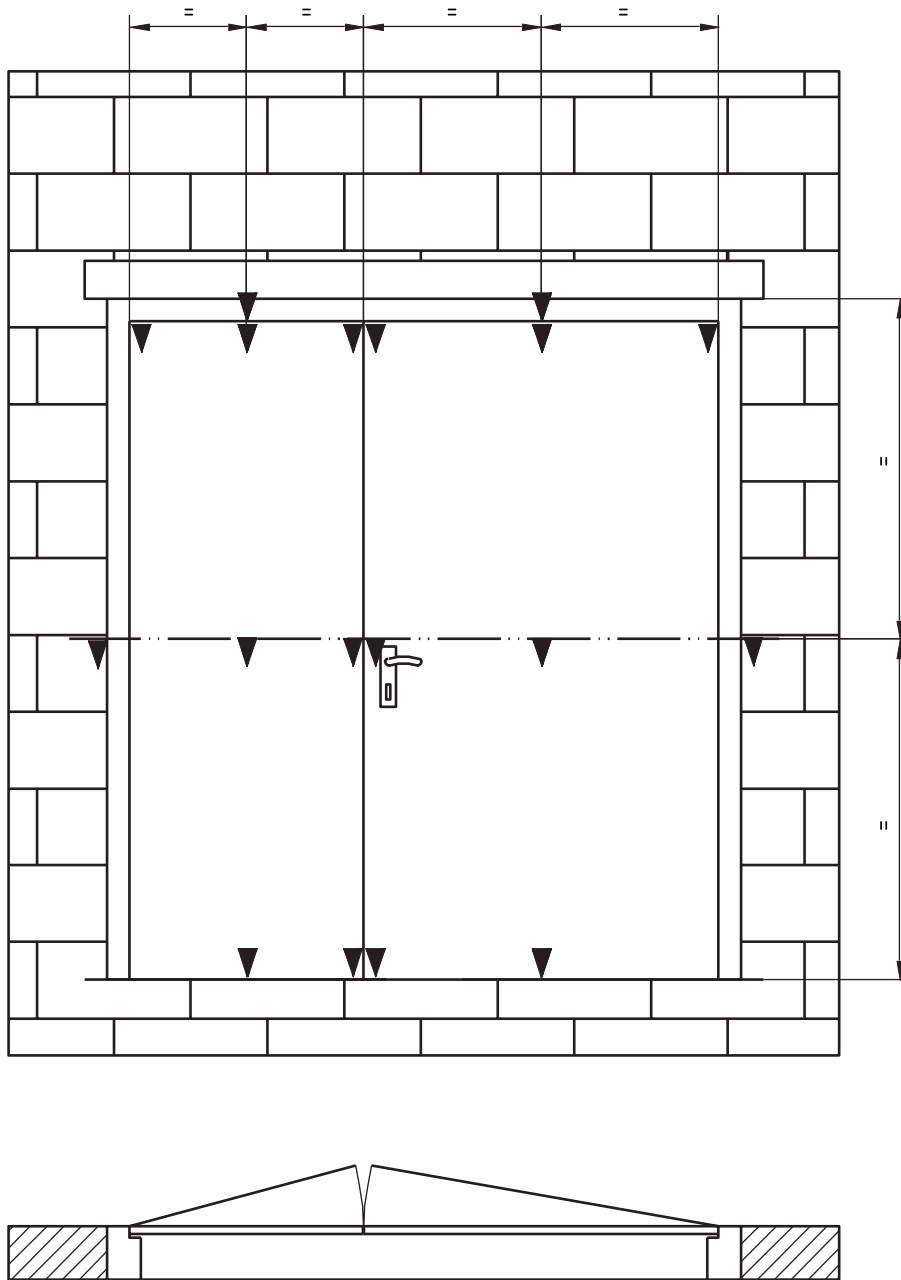

Key

- ▼ suggested positions for measuring deformation

Figure 29 — Suggested positions for deformation measurements — Double-leaf door assemblies

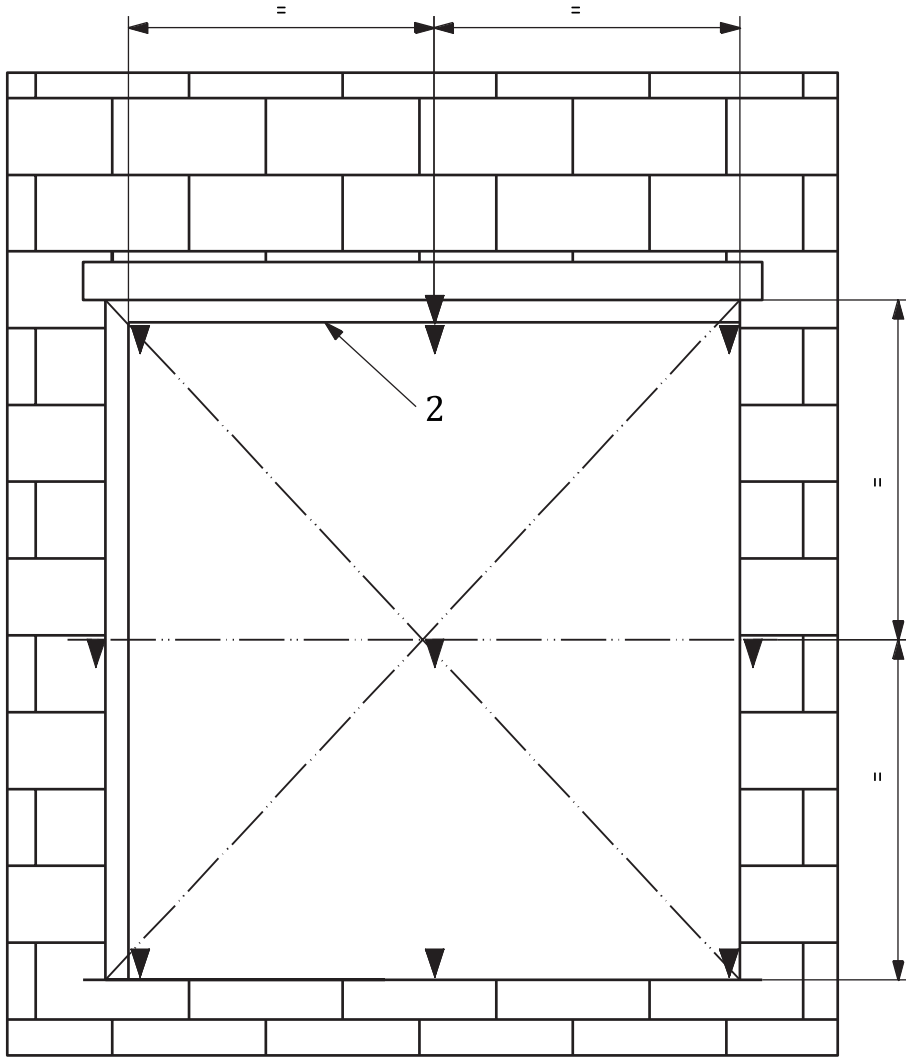

- Key**
- ▼ suggested positions for measuring deformation
 - 2 track

Figure 30 — Suggested positions for deformation measurements — Sliding/folding door assemblies

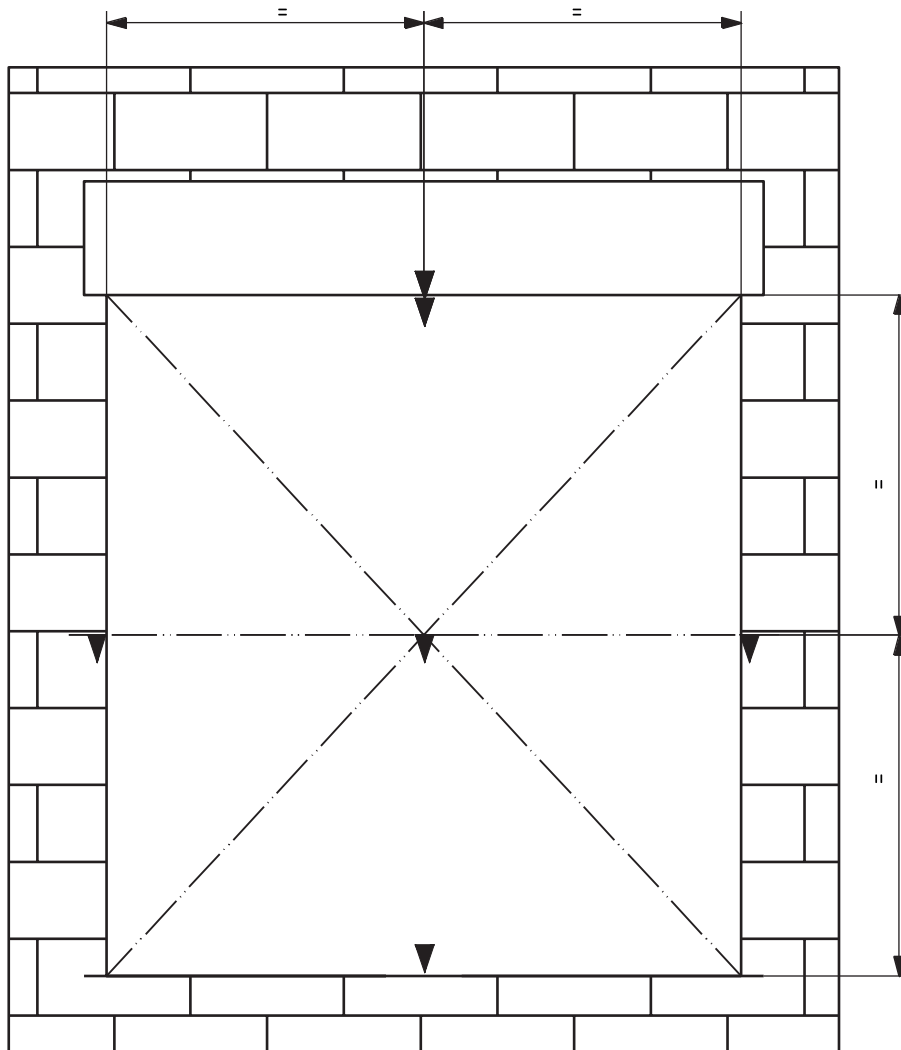

Key

▼ suggested positions for measuring deformation

Figure 31 — Suggested positions for deformation measurements — Roller shutter door assemblies

10 Test procedure

10.1 Before the fire test, an examination shall be carried out according to the sequence in [10.1.1](#) to [10.1.3](#).

10.1.1 Gap measurements

10.1.1.1 The clearance between moving components and fixed components of the door or shutter assembly (e.g. between door leaf/leaves and the frame) shall be measured. Sufficient measurements shall be made to adequately quantify the gaps. There shall be a minimum of three measurements made along each side, top and bottom of each leaf of the door. Measurements to determine the gaps shall be made at distances not greater than 750 mm apart and shall be given to an uncertainty not exceeding $\pm 0,5$ mm. Inaccessible gaps shall be measured indirectly. [Figures 9](#) to [12](#) illustrate examples of the measurements taken at various positions for different door edge/frame rebate types.

10.1.1.2 If the gaps measured by the laboratory are not within those defined in [7.4](#) before the test, then the test result can restrict the direct field of application.

10.1.2 Retention force measurements

10.1.2.1 The retention forces for all door assemblies that incorporate closing devices and that are meant to be opened unaided by mechanical power shall be measured. The closing mechanism provides assistance by retention of the specimen.

10.1.2.2 For each door leaf, the retention force shall be determined as described in [10.1.2.3](#). For double action doors, the moment shall be determined for each direction of opening and, for folding doors, the force shall be determined in the direction of opening.

10.1.2.3 The retention forces for all door assemblies that incorporate closing devices operated by egressing personnel with mechanical assistance shall be measured as follows: Open the test door slowly, using a force gauge attached to the handle and operating against the direction of closing, to a distance of 100 mm away from its closed position. Record the highest gauge reading between the closed and 100 mm positions.

10.1.3 Final setting

10.1.3.1 Prior to the fire test, the door or shutter shall be subjected to a final closing involving opening the assembly to a distance of approximately 300 mm and returning it to the closed position. When applicable, this shall be done by the closing device. If the assembly does not contain any closing device or it cannot be used in the furnace, then the door assembly shall be closed by hand.

10.1.3.2 Doors may be latched prior to the fire test but shall not be locked unless the door can be retained in the closed position during normal use only by utilizing the lock (i.e., there is no latch or closing device to hold the door in the closed position). This condition is applicable only to doors normally maintained in a locked position. No key shall be left in the lock.

10.1.3.3 If the final setting procedures are carried out with the specimen in position on the furnace, then the furnace shall be in an ambient pressure condition (i.e. without any mechanical ventilation activated).

10.2 Carry out the test and evaluate compliance with the integrity and insulation criteria using the equipment and procedures specified in ISO 834-1.

10.3 The 6 mm gap gauge shall not be employed at the cill of the door or shutter assembly.

10.4 When monitoring for insulation, the roving thermocouple shall not be employed where a fixed thermocouple is not permitted.

10.5 Details of the procedure for assessing radiation are given in ISO 3009.

11 Performance criteria

11.1 Integrity

The specimen shall be evaluated against the integrity criteria specified in ISO 834-1. These are the times for which the test specimen continues to maintain its separating function during the test without either

- a) causing the ignition of a cotton pad applied in accordance with ISO 834-1:1999, 8.4.1; or
- b) permitting the penetration of a gap gauge, as specified in ISO 834-1:1999, 8.4.2; or
- c) resulting in sustained flaming on the unexposed surface in excess of 10 s duration.

11.2 Insulation

When insulation is required, door or shutter assemblies shall comply with the following criteria.

- a) For door or shutter assemblies that incorporate discrete areas of different thermal insulation, compliance with the insulation criteria shall be determined separately for each area.
- b) The specimen shall be evaluated against the maximum temperature rise criterion specified in ISO 834-1 (180 °C) with the exception that the limit for temperature rise of the frame of the door or shutter assembly shall be 360 °C. Compliance shall be derived from temperatures recorded from the thermocouples specified in [9.1.2](#), [9.2](#), and [9.3](#) and the roving thermocouple subject to the provisions given in [10.4](#).
- c) The specimen shall be evaluated against the average temperature rise criterion specified in ISO 834-1 (140 °C). Compliance shall be derived from temperatures recorded from the thermocouples specified in [9.1.2](#).

12 Test report

In addition to the items required by ISO 834-1, the following shall also be included in the test report:

- a) reference that the test was carried out in accordance with this document, i.e. ISO 3008-1:2019;
- b) details of how the test specimen was verified, as described in [6.5](#);
- c) reference to which standard supporting construction was chosen, if appropriate, and details of the cill construction as required by [7.3.4.3](#);
- d) description of the associated supporting construction, if appropriate; the construction details of the associated supporting construction shall be verified in the same way and shall be as thoroughly described as those of the test specimen;
- e) information concerning the conditioning of the supporting construction in the light of the relaxations allowed in [Annex A](#);
- f) measurements as required by [10.1.1](#);
- g) retention forces as required by [10.1.2](#);
- h) information concerning any mechanical conditioning performed upon the test specimen;
- i) result stated in terms of the elapsed time, in completed minutes, between the commencement of heating and the time to failure of insulation and integrity.

13 Field of direct application of test results

13.1 General

13.1.1 The field of direct application of test results is restricted to governing the allowable changes to the test specimen following a successful fire-resistance test. These variations can be introduced automatically without the need for the sponsor to seek additional evaluation, calculation or approval.

13.1.2 When extended product size requirements are envisaged, the dimensions of certain components within the test specimen can be less than those intended for use at full size in order to maximize the extrapolation of the test results by modelling the interaction between components at the same scale.

13.1.3 Unless otherwise stated in [13.2](#) to [13.5](#), the construction of the door or shutter assembly shall be the same as that tested. The number of leaves and the mode of operation (e.g. sliding, swinging, single action or double action) shall not be changed.

13.1.4 Where the paint finish is not expected to contribute to the fire resistance of the door, alternative paints are acceptable and may be added to door leaves or shutter or frame products for which unfinished specimens were tested. Where the paint finish contributes to the fire resistance of the door (e.g. intumescent paints), then no change shall be permitted.

13.1.5 Decorative laminates and timber veneers up to 1,5 mm thickness may be added to the faces (but not the edges) of hinged doors that satisfy the insulation criteria (normal or supplementary procedure). Decorative laminates and veneers applied to leaves other than timber, and those in excess of 1,5 mm thickness, shall be tested as part of the test specimen. For all products tested with decorative laminate faces, the only variations possible shall be within similar types and thicknesses of material (e.g. for colour, pattern, manufacturer).

13.2 Timber constructions

13.2.1 The thickness of the door leaves shall not be reduced but may be increased. Likewise, the door leaf thickness and/or density may be increased provided the total increase in mass is not greater than 25 %.

13.2.2 For timber-based panel products (e.g. particle board, block board), the composition (e.g. type of resin) shall not change from that tested. The density shall not be reduced but may be increased.

13.2.3 The cross-sectional dimensions and/or the density of the timber frames (including rebates) shall not be reduced but may be increased.

13.3 Steel constructions

13.3.1 The dimensions of steel wrap-around frames may be increased to accommodate increased supporting construction thicknesses. The thickness of the steel may also be increased by up to 25 %.

13.3.2 The number of stiffening elements for un-insulated doors and the number and type of fixing of such members within the panel fabrication may be increased proportionally with the increase in size but shall not be reduced.

13.4 Glazed constructions

13.4.1 The type of glass and the edge fixing technique, including type and number of fixings per metre of perimeter, shall not be changed from those tested.

13.4.2 The number of glazed apertures and each of the dimensions of glass in each pane included within a test specimen of timber or steel may be decreased but shall not be increased beyond the tested pane size.

13.4.3 The distance between the edge of the glazing and the perimeter of the door leaf or the distance between glazed apertures shall not be reduced from those incorporated in test specimens. Other positioning within the door can be modified only if this does not involve the removal or repositioning of structural members.

Attention is drawn to the fact that if relocating the glazing panel moves it closer to the radiometer, then there is an increase in the radiation measured.

13.5 Fixings/hardware

13.5.1 The number of fixings used to attach fire-resisting doors to supporting constructions may be increased but shall not be decreased and the distance between fixings may be reduced but shall not be increased.

13.5.2 Changes in hardware are permitted, provided that it has been demonstrated (in fire testing in accordance with this document), that their inclusion in other door sets of a quantifiably similar construction and configuration is not a cause of integrity failure.

13.5.3 Any movement restrictors, such as locks, latches and hinges, may be increased but shall not be decreased.

Annex A **(normative)**

Conditioning requirements for supporting constructions

A.1 General

ISO 834-1 specifies that the test specimen shall be fully conditioned so that its strength and moisture content are approximately that experienced in service. To impose that requirement on masonry or concrete supporting constructions can result in conditioning times of several months, which would be impractical. The purpose of this annex is to specify the conditioning requirements necessary for supporting constructions. In doing this, consideration is given to those aspects of conditioning (moisture content, strength) that can affect the fire-resistance performance (integrity and insulation) of the test construction. The requirements represent a compromise between the need to test specimens fully conditioned and the practical aspects of laboratory testing. The requirements apply to both standard and associated supporting constructions.

A.2 Requirements

A.2.1 Concrete or masonry supporting constructions that use water-based mortars, e.g. as described in ISO 834-1, shall be conditioned for a period of 28 days before fire testing.

A.2.2 Masonry walls constructed with masonry units that have been conditioned in accordance with ISO 834-1 and that use special adhesives that cure in short periods shall be conditioned for sufficient time for the special adhesive to cure or for 24 h, whichever is the longer.

A.2.3 Lightweight standard supporting constructions, e.g. as described in ISO 834-1, shall be conditioned in accordance with ISO 834-1, with the exception of sealing materials, such as gypsum plaster used to fill in the joints between the outer layers of the facing boards, for which a period of 24 h is sufficient.

A.2.4 Hygroscopic sealing materials used to seal the gap between the supporting construction and the door assembly where the gap is ≤ 10 mm wide shall be conditioned for seven days before fire testing.

A.2.5 Hygroscopic sealing materials used to seal the gap between the supporting construction and the door assembly where the gap is > 10 mm wide shall be conditioned for 28 days before fire testing.

A.2.6 Door frames that incorporate water-based materials, e.g. steel frames that have back-filled or pressure-grouted frames, shall be conditioned for a period of 28 days before fire testing.

Annex B (informative)

Estimation of radiant heat flux using measured surface temperature and the Stefan-Boltzmann law

B.1 Introduction

Energy is radiated from one surface to another at a rate that is proportional to the emissivity of the radiating surface, the emissivity of the receiving surface, the relative size and orientation of the surfaces (i.e. “view factor”) and the difference in the fourth powers of the absolute temperature of the surfaces. This relationship for the total radiated energy, Q_{rad} , expressed in watts, is described mathematically by the Stefan-Boltzmann law as given in [Formula \(B.1\)](#):

$$Q_{\text{rad}} = A\varepsilon_1\varepsilon_2f\sigma(T_2^4 - T_1^4) \quad (\text{B.1})$$

where

- A is the area of the radiating surface, expressed in square metres;
- ε_1 is the emissivity of the receiving surface;
- ε_2 is the emissivity of the radiating surface;
- f is the view factor;
- σ is the Stefan-Boltzmann constant, equal to $5,67 \times 10^{-8} \text{ W/m}^2\cdot\text{K}^4$;
- T_1 is the temperature of the receiving surface, expressed in kelvin;
- T_2 is the temperature of the radiating surface, expressed in kelvin.

This is the principle that is used in the design, application and calibration of radiometers and optical/infrared pyrometers. Where it is practical to measure the temperature of a radiating body accurately and if the effective emissivity of the surface is known, the radiated energy can be readily and accurately determined.

B.2 Application

B.2.1 General

The measurement method specified in [9.5](#) uses a radiometer positioned such that the intent is to measure the total radiation from the specimen surface to a “black body” with a view factor of one. Thus, to estimate the equivalent radiation based on the above equation, it is appropriate to assume a view factor of 1, an emissivity of receiving surfaces of 1 and a temperature of the receiving surfaces equal to the laboratory ambient temperature. If the laboratory space is large, the last assumption has a relatively small effect on the uncertainty of the calculation. However, if there is a surface near the specimen (such as a laboratory wall) which experiences significant heating, the temperature and emissivity of that surface can be used in the calculation.

B.2.2 Specimen temperature measurement

The specimen surface temperature is measured in sufficient locations to allow for calculation of an area-weighted average surface temperature. This generally requires the placement of sensors at locations where thermal bridges through the sample are located, as well as several in areas where construction is uniform. It is important to attach the sensors in a manner that measures the true surface temperature as accurately as possible. The use of insulating pads should be avoided. For metal surfaces, brazing or welding thermocouples to the surface is recommended, or junctions may be riveted or screwed to the surface. For other materials, thermocouples should be embedded into the surface slightly and held in place with high-temperature adhesive or aluminium foil tape painted to match the underlying surface emissivity. A minimum of 100 mm of the thermocouple lead wire adjacent to the measuring junction should be placed in contact with the surface to avoid thermal shunting.

B.2.3 Specimen emissivity

For most materials, emissivity values can be obtained from reference handbooks. Most building materials have emissivities in a range of 0,85 to 0,95, but values for materials such as glass and polished metals can vary substantially. In cases where the emissivity of a sample cannot be determined otherwise, it is recommended that it be measured with an emissometer. It should be noted, however, that the emissivity of some materials can change substantially during heating due to surface oxidation and other effects.

B.3 Example calculation

The following is an example of the calculation of the total radiated energy, Q_{rad} , expressed in watts, using the Stefan-Boltzmann law as given in [Formula \(B.1\)](#):

$$Q_{\text{rad}} = 2,5 \cdot 0,9 \cdot 1,5,67 \times 10^{-8} \cdot (540^4 - 293^4) \quad (\text{B.2})$$

where

T_2 is equal to 540 K;

T_1 is equal to 293 K;

ε_1 is equal to 0,90;

A is equal to 2,5 m².

If the area is normalized to unity and the result is divided by 1 000, the equation provides the radiant flux from the surface of 3,96 kW/m².

Bibliography

- [1] ISO 5925-1, *Fire tests — Smoke-control door and shutter assemblies — Part 1: Ambient- and medium-temperature leakage tests*
- [2] ISO/TR 12470-2, *Fire-resistance tests — Guidance on the application and extension of results from tests conducted on fire containment assemblies and products — Part 2: Non-loadbearing elements*

This page has been intentionally left blank

Bureau of Indian Standards

BIS is a statutory institution established under the *Bureau of Indian Standards Act, 2016* to promote harmonious development of the activities of standardization, marking and quality certification of goods and attending to connected matters in the country.

Copyright

BIS has the copyright of all its publications. No part of these publications may be reproduced in any form without the prior permission in writing of BIS. This does not preclude the free use, in the course of implementing the standard, of necessary details, such as symbols and sizes, type or grade designations. Enquiries relating to copyright be addressed to the Head (Publication & Sales), BIS.

Review of Indian Standards

Amendments are issued to standards as the need arises on the basis of comments. Standards are also reviewed periodically; a standard along with amendments is reaffirmed when such review indicates that no changes are needed; if the review indicates that changes are needed, it is taken up for revision. Users of Indian Standards should ascertain that they are in possession of the latest amendments or edition by referring to the website- www.bis.gov.in or www.standardsbis.in.

This Indian Standard has been developed from Doc No.: CED 36 (17841).

Amendments Issued Since Publication

Amend No.	Date of Issue	Text Affected

BUREAU OF INDIAN STANDARDS

Headquarters:

Manak Bhavan, 9 Bahadur Shah Zafar Marg, New Delhi 110002
Telephones: 2323 0131, 2323 3375, 2323 9402

Website: www.bis.gov.in

Regional Offices:

	Telephones
Central : 601/A, Konnectus Tower -1, 6 th Floor, DMRC Building, Bhavbhuti Marg, New Delhi 110002	{ 2323 7617
Eastern : 8 th Floor, Plot No 7/7 & 7/8, CP Block, Sector V, Salt Lake, Kolkata, West Bengal 700091	{ 2367 0012 2320 9474
Northern : Plot No. 4-A, Sector 27-B, Madhya Marg, Chandigarh 160019	{ 265 9930
Southern : C.I.T. Campus, IV Cross Road, Taramani, Chennai 600113	{ 2254 1442 2254 1216
Western : Plot No. E-9, Road No.-8, MIDC, Andheri (East), Mumbai 400093	{ 2821 8093

Branches : AHMEDABAD. BENGALURU. BHOPAL. BHUBANESHWAR. CHANDIGARH. CHENNAI. COIMBATORE. DEHRADUN. DELHI. FARIDABAD. GHAZIABAD. GUWAHATI. HIMACHAL PRADESH. HUBLI. HYDERABAD. JAIPUR. JAMMU & KASHMIR. JAMSHEDPUR. KOCHI. KOLKATA. LUCKNOW. MADURAI. MUMBAI. NAGPUR. NOIDA. PANIPAT. PATNA. PUNE. RAIPUR. RAJKOT. SURAT. VISAKHAPATNAM.