भूस्खलन नियंत्रण उपाय — दिशानिर्देश

(पहला पुनरीक्षण)

Landslide Control Measures —
Guidelines

(First Revision)

ICS 93.020

© BIS 2024



भारतीय मानक ब्यूरो
BUREAU OF INDIAN STANDARDS
मानक भवन, 9 बहादुर शाह ज़फर मार्ग, नई दिल्ली - 110002
MANAK BHAVAN, 9 BAHADUR SHAH ZAFAR MARG
NEW DELHI - 110002
www.bis.gov.in www.standardsbis.in

July 2024

Price Group 11

FOREWORD

This Indian Standard (First Revision) was adopted by the Bureau of Indian Standards, after the draft finalized by the Hill Area Development Engineering Sectional Committee had been approved by the Civil Engineering Division Council.

Landslides are being increasingly viewed as an important natural hazard due to large scale damages inflicted by them every year. It is a known fact that a majority of the landslides are triggered by natural causes including concentrated rain falls, cloud bursts, earthquakes and other related factors and hence are difficult to predict their occurrences.

However, the landslide problems have considerably increased in recent times due to unplanned man-made activities as well. Large-scale construction works involving dams and other hydroelectric projects, mining activities, construction of houses and extensive expansion of road networks as well as deforestation, often encroached into the fragile eco-system of the hills, leading to instability of hill slopes. At the same time, consistently increasing requirements for modern living including uninterrupted communication systems to far-flung areas, road and rail networks and urbanization initiatives cannot be completely overlooked. Hence, this standard has been formulated with a view to understand the general landslide phenomenon in the hills and their evaluation mainly for planning effective correction measures.

This standard was first published in 1999. This revision has been brought out to incorporate the experiences gained from the use of this standard since its publication as well as to include other recent technologies in landslide control measures. In addition, the following modifications/additions have also been done

- a) Landslide symbols to be used in the map preparation have been included along with figure;
- b) Detailed investigation procedure has been indicated, which include field investigations, laboratory testing, and desk work;
- c) Stability measures are reclassified with relevant figures; and
- d) Reference to various Indian Standards has been updated.

The composition of the Committee responsible for the formulation of this standard is given in [Annex B](#).

For the purpose of deciding whether a particular requirement of this standard is complied with, the final value, observed or calculated, expressing the result of a test or analysis, shall be rounded off in accordance with IS 2 : 2022 'Rules for rounding off numerical values (*second revision*)'. The number of significant places retained in the rounded off value should be the same as that of the specified value in this standard.

*Indian Standard***LANDSLIDE CONTROL MEASURES — GUIDELINES***(First Revision)***1 SCOPE**

This standard covers the guidelines for selection of various landslide control measures for effectively correcting slope instabilities such as landslides and to reduce landslide occurrences in hill areas.

2 REFERENCES

The standards listed in [Annex A](#) contain provisions, which through references in this text constitute provisions of this standard. At the time of publication, the editions indicated were valid. All standards are subject to revision and parties to agreements based on this standard are encouraged to investigate the possibility of applying the most recent edition of these standards.

3 LANDSLIDE DEFINITION

A landslide may be defined as the downward and outward movement of a mass of rock, soil, debris, or a combination of these materials on a slope under the influence of gravity. Landslides occur when the driving forces (force of gravity, hydrostatic pressure, tectonic forces, etc) exceeds the resisting forces holding the materials in place, causing them to slide or flow downhill.

4 CLASSIFICATION OF LANDSLIDES

Landslides may be classified broadly into five categories namely falls, topples, slides, lateral spreads and flows. When more than one type of landslide is involved in the failure, it can be termed as complex. These five categories are further classified on the basis of type of material involved (see [Fig. 1](#)) in the landslides. The [Fig. 1](#) provides a brief account of the classification.

**5 LANDSLIDE NOMENCLATURE/
TERMINOLOGY AND LANDSLIDE
SIGNATURES**

Type of movements commonly observed during landslide in hills/natural slopes is illustration in [Fig. 1](#).

5.1 Crown — Practically, it is the portion of undisturbed part of ground and is just adjacent to the main scarp.

5.2 Displaced Material — It is the slope mass that got displaced and moved away from its original position on the slope.

5.3 Flank — These are the sides of the landslide, which are unaffected by movements. The right flank and left flank of the slide are annotated looking downslope from the crown or looking towards direction of movement.

5.4 Foot — It is a portion of the displaced material that lies down the slope from the toe of the surface of rupture to the toe of the landslide.

5.5 Head — The upper parts of the slide material along the contact between the displaced material and the main scarp.

5.6 Main Scarp — It is a steep surface on the undisturbed ground around the periphery of the slide and caused by the movement of slide material away from the undisturbed ground. Main scarp and its projection, under the displaced material becomes the surface of rupture.

5.7 Minor Scarp — The steep exposed surface along both flank of the slide extending from the Head of the slide.







5.8 Surface of Rupture — It is the surface forming the boundary of the displaced material from top of the main scarp to the toe of surface of rupture.

5.9 Toe — It is the bottom margin of the slope, from where the material got displaced and it represents end of movement of material, which has maximum distant from the main scarp.

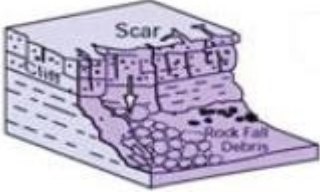
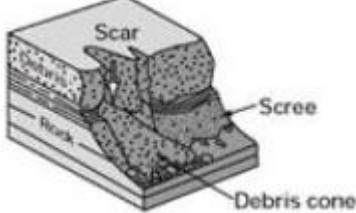
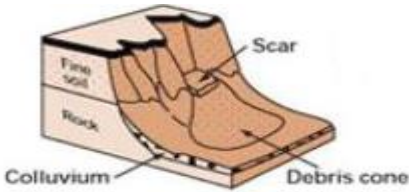
5.10 Toe of Surface of Rupture — It is the intersection (often buried) of lowest part of the surface of rupture with the original ground surface.

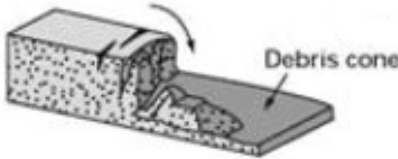
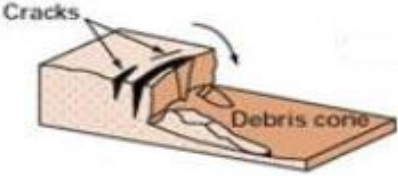
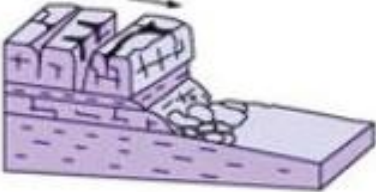
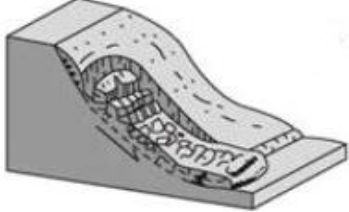
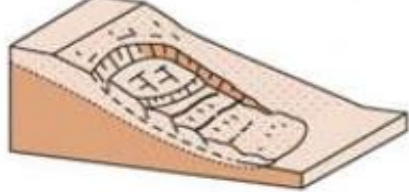
5.11 Zone of Accumulation — It is the area, where the displaced material lies above the original ground surface.

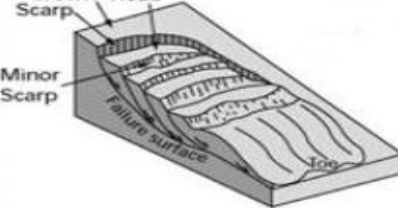
5.12 Zone of Depletion — It is the area within landslide where slope forming material gets displaced from original ground/slope surface along surface of rupture.

Type of Movement		Type of Material			Possible Control Measures
		Bed Rock	Engineering Soils		
			Predominantly Coarse	Predominantly Fine	
Falls		Rock fall 	Debris fall 	Earth fall 	Geotextile nailed on slope/spot bolting
		Rock topple 	Debris topple 	Earth topple 	
Slides	Translational	Rock slide 	Debris slide 	Earth slide 	Alteration of slope profile and Slides earth and rock fill buttress
	Rotational	Rock slide 	Debris slide 	Earth slide 	





Type of Movement	Type of Material		Possible Control Measures	
	Bed Rock	Engineering Soils		
		Predominantly Coarse Predominantly Fine		
Lateral spreads	<p style="text-align: center;">Rock/debris spread</p> 		<p style="text-align: center;">Earth spread</p> 	Check dams along gully
Flows	<p style="text-align: center;">Rock flow</p> 	<p style="text-align: center;">Debris flow</p> 	<p style="text-align: center;">Earth flow</p> 	Series of check dams
Complex				Combined system

FIG. 1 LANDSLIDE CLASSIFICATION AND NOMENCLATURE

6 LANDSLIDE SYMBOLS

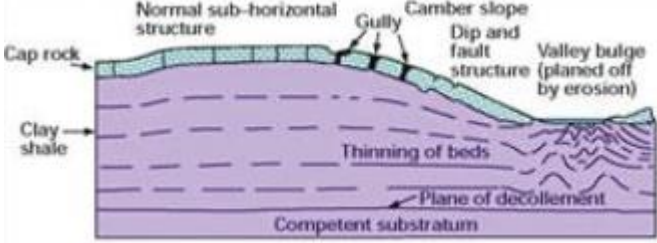
Landslide symbols are required to mark different type of landslides on map. Some of the standard notations to indicate the different landslides are shown in (see [Fig. 2](#)). These six landslide symbols are indicating old landslide scar, active landslide scar, slide, fall, flow and creep may be used to mark the presence of different landslides.

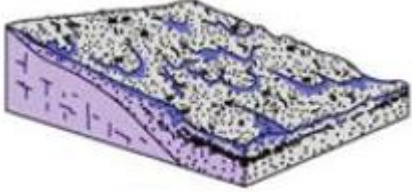
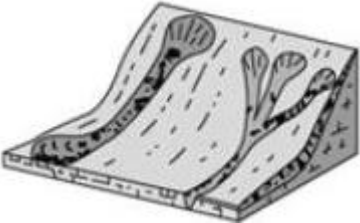
7 INVESTIGATIONS

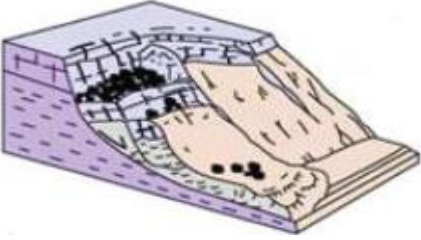
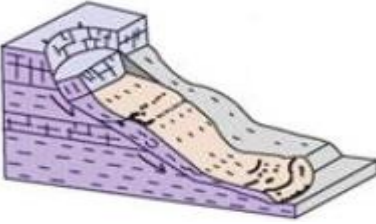
Before undertaking the process of implementation of control measures, initially study the already available maps of the area such as landslide hazard zonation as per [see [IS 14496 \(Part 1\)](#) and [\(Part 2\)](#)] or landslide risk assessment maps as per [IS 17162](#). Later the work starts with the preparation of basic field maps and investigations, to understand the nature of instability and its present status so as to plan appropriate stabilization measures and their sequence of activities, the field investigations should indicate the type of failure, geographical location, geological, geomorphological, environmental and hydrological conditions. Concurrent with field investigations, laboratory investigations including analysis of slope materials for their strength and other properties shall also be taken up.

7.1 Field Investigations

Initially, the area affected by landslide shall be identified based on initial field works and marked with failure boundaries. Later an additional area including about 50 m to 100 m beyond the inferred landslide boundary shall be covered under detailed investigations. The field investigations include the following:

- a) Preparation of a topographical survey map as per [IS 17163](#), of the area on 1 : 500 to 1 : 1 000 scale having 1 m contour interval indicating important features like break in slope locations, seepage points, man-made structures such as buildings, bridge, wall, water storage and other such features. The surveying can be done accurately with total station or remotely using high resolution satellite imageries, GPS based drone survey or drone based LiDAR with GPS survey;
- b) Preparation of a detailed geological map of the area on the same scale showing distribution of various litho-units as well as structural pattern including strike and dip of beds, shear zones and other geological features. Consideration of drainage map is

useful in the case of flow-like, landslides to understand the drainage pattern.

- c) Preparation of geological sections along and across the general slope to understand the geological structures with depth, the causative factors of instability and type of failure. The sections should also show the projected surface of rupture with reference to slope surface wherever required;
- d) Estimation of rock/soil mass properties particularly shear strength properties of slope materials using laboratory and field methods;
- e) Carrying out back analysis for estimating the shear strength properties (' c ' and ' ϕ ') for comparative study and to arrive at a reasonable value of shear strength; and
- f) Later, calculation of factor of safety (FOS) for the apparently unstable slope is to be carried out to understand the status of stability in order to plan the extent of stability measures required for the site. This can be done manually or using computer programs after understanding the type of failure as well as the failure surface pattern.

7.2 Laboratory Testing

The following laboratory testing works can be carried out on the slope materials:

- a) Geological tests including thin section studies for understanding mineral assemblage, weathering conditions, texture/structure of rocks and rock types in addition to evaluating grain size analysis, soil types and water content; and
- b) Geotechnical tests to study properties of slope forming material like rock/soil, which includes grain size analysis of soil, compressive strength and shear strength of the rock/soil. Shear strength parameters (' c ' and ' ϕ ') of the rock may be determined along the geological discontinuity as per the requirement and site conditions. The above tests shall be repeated to find out the best average values of the properties of the samples.

For detailed laboratory and field testing please (see [IS 17163](#)).

7.3 Desk Work

It is important to determine the type of failure for all the landslides. In case of rock slides, it is essential to collect adequate structural data of bedding, joints, shear zones and other structures during field investigations. Later, stereo-net analysis of geological structural data has to be carried out along with slope data to finally determine the type of failure. Factor of safety (FOS) can be calculated accordingly either using relevant equations for different types of slides or using computer programs. In case of soil, the failure may be generally rotational in nature or planner in some cases. The planner failure along rock and debris interface (rock surface controlled shallow debris failure) can be termed as talus failure. The factor of safety can be determined using field cross-sections as well as material properties obtained from laboratory tests. A FOS value of 1.0 indicates that the slope is just stable indicating that the mobilizing and the resisting forces are nearly equal. Any value of FOS less than 1.0 indicates that the slope is unstable with lesser the value more the instability of the slope. Accordingly, appropriate remedial measures are planned to improve the FOS value to reach more than 1.0 or up to the desired value, which is dependent on the field conditions and the planned civil structure, if any, in the vicinity.

It may be often difficult to calculate the FOS values for landslides such as fall, topple, spread and flow.

8 STABILITY MEASURES

In case of unstable slopes, control measures are required to stabilize the slopes. Often more than one control measure is implemented depending on the field conditions. Since the landslide phenomenon is basically a gravitational movement, the control measures are mainly aimed to reduce/contain the factors causing the gravitational movements, either by increasing the shearing resistance or by reducing the effect of mobilized shear force along plane of sliding.

All the stabilization measures can be classified into the following types:

- a) unloading of unstable slope material or alteration of slope geometry;
- b) strengthening the toe of landslide;
- c) mitigating water related problems;
- d) increasing the shear strength of slope materials; and
- e) creating a surface protective cover.

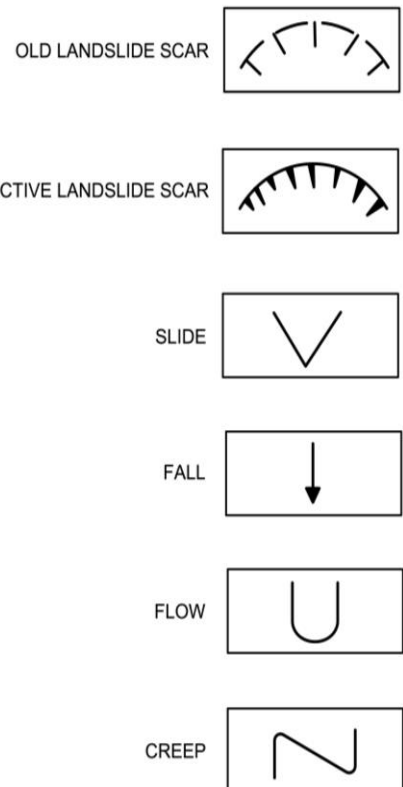
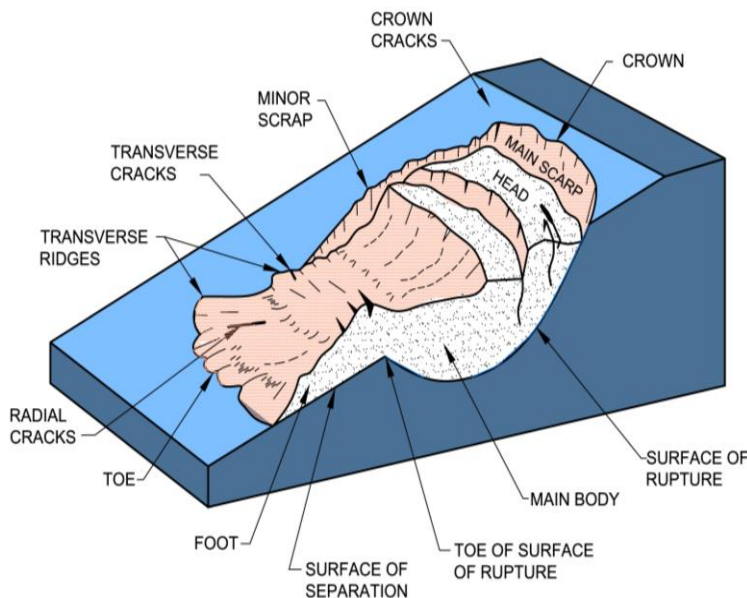

FIG. 2 LANDSLIDE NOMENCLATURE AND SYMBOLS FOR MAPS

Since a set of control measures is commonly used, it is also important to understand the sequence in which they have to be implemented at the site. The selection of control measures is basically dependent on the landslide failure type, geographical location, geological, geomorphological and environmental conditions. Moreover, it is also dependent on the importance of the area and the budgetary provisions. Some slopes may require some immediate support measures before long-term measures are adopted. Therefore, remedial measures may be divided into:

- a) short term; and
- b) long term remedial measures.

Short term measures mainly include immediate stabilization techniques to arrest the sliding tendency of the slope. Removal of visibly unstable slope materials, draining of excess water from the slope and other such measures are often adopted so that the slope can attain temporary stability. After this, long term measures can be adopted. Various long term control measures falling under different categories are discussed below.

8.1 Alteration of Slope Geometry

Altering the geometry of a slope is one of the efficient ways to improve the stability of unstable slopes. The common approach is to remove slope material from areas close to the top of the unstable zone causing flattening of the slope in addition to supporting the toe suitably. The method is more suitable for soil slopes with rotational failure. In this type of failure, the gravitational force in the upper portion is large and hence unloading will provide effective benefits. In case of rock slopes, it is a bit complex process as it is mainly dependent on the disposition of geological discontinuities and their spacing in addition to other related factors. Few methods related to alteration of slope geometry are discussed below.

8.1.1 Removal of Unstable Materials

Unstable material can be removed partially or completely depending on the field conditions and requirements. In case of shallow soil profiles, complete removal of soil may be a permanent solution. For deep soil profiles, selective removal from the top portion will help to increase the stability of the slope.

8.1.2 Flattening of Slopes with or without Benches

Slope forming soil materials can be broadly classified into recent as well as old and well compacted. Recent soil could be alluvium or other deposited materials of young age (less than 1 million years). These materials have less stability characters because of less compaction and no or least cemented nature of particles. In most cases, it is desirable to provide a cut slope of 30° or less over a height of maximum 6 m. In case of complex soil materials or for higher slopes, the slope angle can be decided on the basis of properties of materials from laboratory tests, surface and subsurface water conditions as well as results of stability analysis.

The older slope materials are generally well-compacted and cemented in nature and hence, have high shear strength, which can be assessed even from surface indications. They are often seen standing stable on even steep to vertical road cut slopes. On a safer side, they can be cut comfortably at 45° over a height of 6 m. In case of higher slopes, it is desirable to provide benches of 2 m to 2.5 m at a height interval of about 6 m.

For rock slopes, the data related to structural discontinuities including attitude and spacing of joints, bedding as well as shear zones are collected from field. This information along with slope direction is analyzed using a stereo net in order to find out unstable wedges and their sizes. This information could be used to design bench width and height of adjoining slopes. However, for most rock slopes, a general cut slope angle of 45° to 60° is adoptable using this criteria, the slope can be designed with a bench width of 1.0 m to 1.5 m for a slope height of 6 m to 8 m for most rock slopes (see [Fig. 3](#)).

8.2 Strengthening Toe of Landslides

The techniques adopted to strengthen the toe of landslide mainly include construction of various types of retaining walls and breast walls. A retaining wall is generally preferred in soil/debris slope, or weathered rock slopes, where it helps to retain the slope materials with a backfill behind the wall. A retaining wall is a structure meant to retain earth pressure against an artificially excavated edge in soil and is used to retain the backfill and maintain difference in the elevation of the two ground surfaces. A retaining wall may be

effectively utilized to tackle the problem of landslide in hill area by stabilizing the fill slopes, cut slopes and unstable slopes. A breast wall is used to sustain earth against a natural slope such as the hillside of a mountain road without a backfill. In fact, it is commonly used to protect rock cut slopes without any backfill behind.

The retaining walls can be better classified as rigid and flexible types based on the materials used, behavior and design. The rigid retaining walls are comparatively rigid in the sense that they may crack when the mobilized stresses exceed the design capacity. The flexible retaining walls can absorb considerable amount of mobilized stresses and still remain stable.

8.2.1 Rigid Retaining Walls

The rigid retaining walls broadly include the following:

- a) Gravity retaining walls including cement stone masonry retaining wall and concrete retaining wall;

- b) RCC cantilever retaining wall;
- c) RCC counterfort retaining wall;
- d) RCC restraining piles and sheet-pile walls;
- e) RCC diaphragm wall;
- f) RCC crib wall; and
- g) Tie back wall.

8.2.1.1 Gravity retaining walls

Gravity retaining walls rely mainly on self-weight to resist lateral earth pressure. They are generally, large in size as the structure requires significant gravity load to withstand soil pressures (see Fig. 4). The design takes into account bearing capacity of soil, sliding, overturning and other forces. It can be constructed out of materials like stones, concrete or brick. For further details, refer [see IS 14458 (Part 1), (Part 2) and (Part 5)].

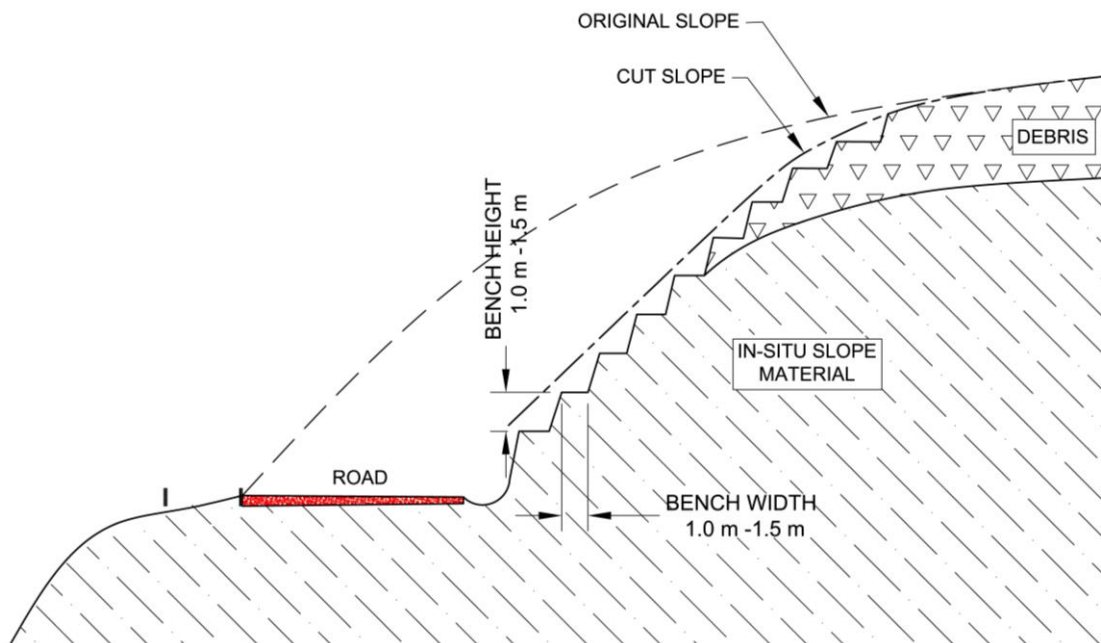

FIG. 3 ALTERATION OF THE GEOMETRY WITH BENCHES ON CUT SLOPE

8.2.1.2 RCC cantilever retaining walls

The cantilever retaining wall is often considered for high cut slopes of 4 m to 8 m and high-volume roads. It is generally made of reinforced concrete walls and works on the principle of leverage. It consists of a thin stem over a base slab. The extension of the base in the hill side is called heel slab and towards the valley, it is called toe slab. The weight of the backfill materials lying above its heel slab help to retain the slope materials at the back against sliding and overturning. A shear key is provided at the bottom surface of the base to increase the shearing resistance (see Fig. 5). In case of poor foundation material or the base often getting saturated with water, it is essential to provide further resistance against sliding. For that purpose, a series of 30 mm diameter holes shall be drilled into the foundation at spacing of about 30 cm for a depth of 2 m to 2.5 m with the help of a jack hammer. These holes after filling with thin grout shall be inserted with 25 mm steel bars and hammered tightly. The steel reinforcements extending above the ground shall be tied with the reinforcements of wall base. A series of 80 mm to 100 mm diameter drainage holes

dipping at around 15° towards road or downslope shall be provided in the stem area at a spacing of 1 m to 1.5 m. These holes shall be provided with double layered wire mesh on the inner hill side of the wall to prevent removal of back-fill through drainage holes. The back-fill should consist of inverted filter materials with suitable protection on surface as suggested in [IS 14458 (Part 5)].

8.2.1.3 RCC counterfort retaining walls

These are cantilever walls supported at the back with counterforts located at right angles to the stem and monolithic with the back of the wall slab (see Fig. 6). The counterforts act as tension stiffeners and connect the wall slab with the base in order to reduce the bending and shearing stresses. Counterforts are particularly preferred in case if the wall heights are high to very high (8 m to 12 m), mainly to reduce the bending movements. The counterforts at the backside are generally equally spaced and are constructed to heights of slightly more than half the height of the slab. The other requirements regarding weep holes and back-fill shall be followed as in the case of cantilever wall.

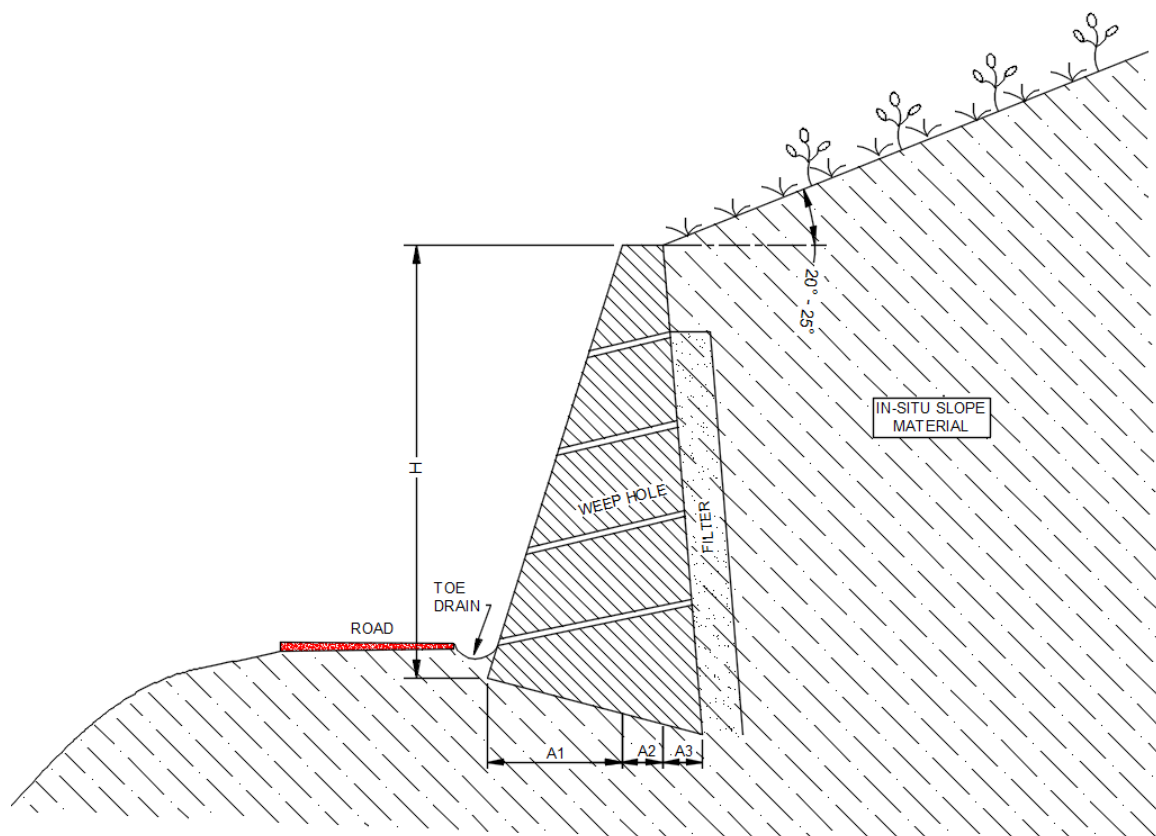

FIG. 4 A TYPICAL SECTION OF A CEMENT STONE MASONRY WALL

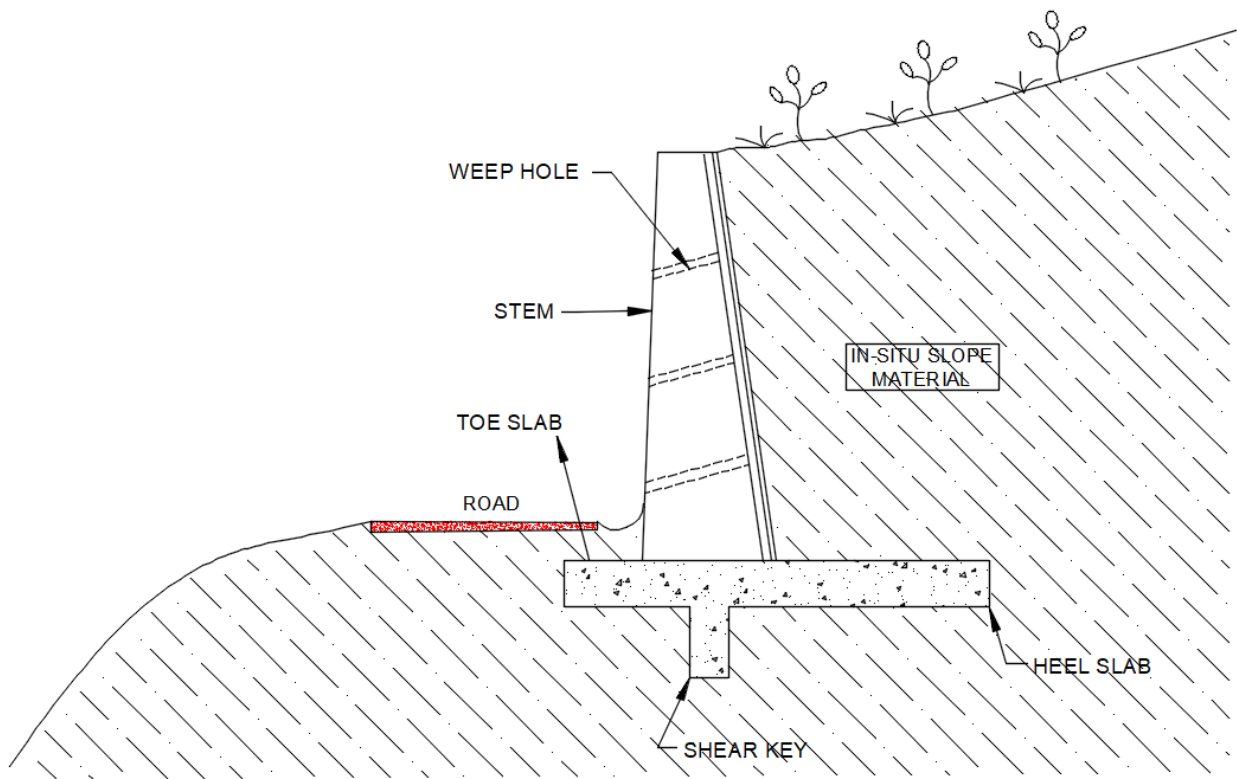

FIG. 5 SECTIONAL VIEW OF A CANTILEVER WALL

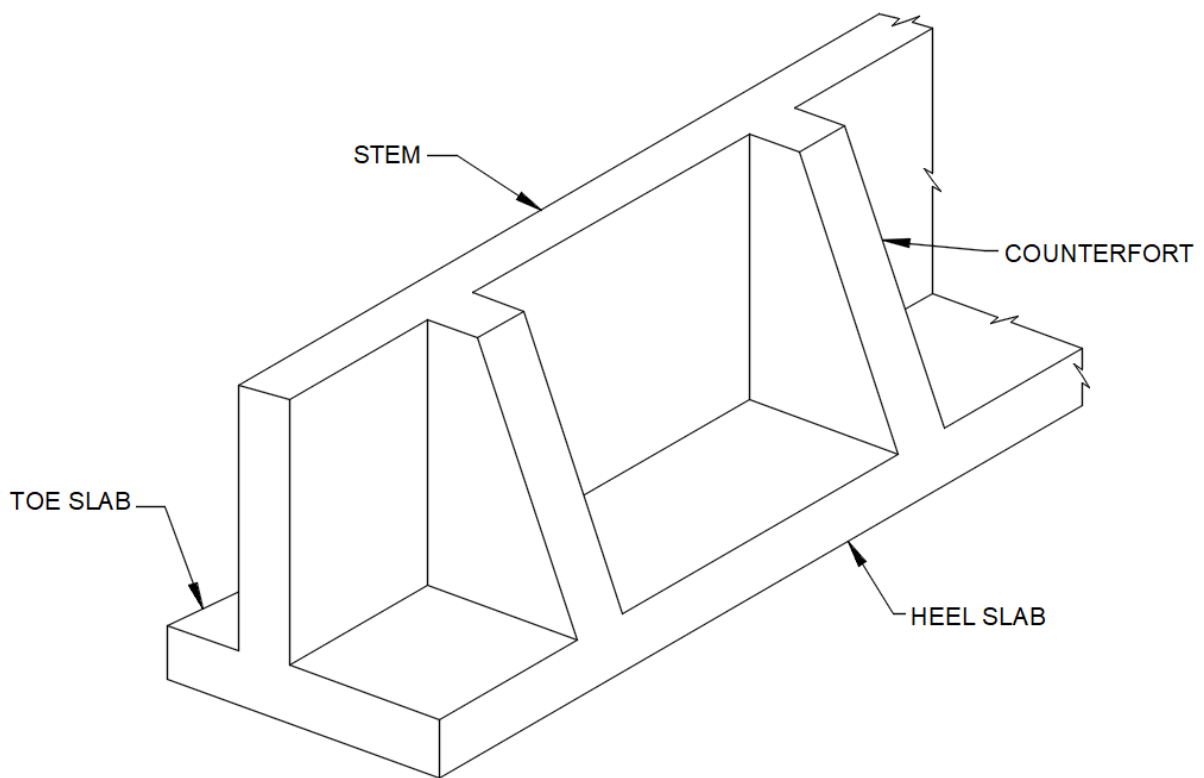

FIG. 6 SCHEMATIC VIEW OF A COUNTERFORT RETAINING WALL

8.2.1.4 Restraining piles and sheet-pile walls

Restraining piles are the suitable remedy for large soil/debris slopes with fairly deep surface of rupture often undergoing creep movements with rotational failure. The moving terrain may have many civil constructions including houses, offices and other structures. Large piles extending to deeper levels surpassing the rupture surface are planned to provide resisting force in the toe area of the slide mass (see Fig. 7). Depending upon the size and weight of the unstable mass, number of piles, their bearing capacity and locations are decided mainly to counter the load of the moving mass. Since the installation work is highly mechanized, the work can be completed fast and effectively.

In places where required space is not available to flatten the slopes or use other gravity type structures to improve slope stability, a wall of piles can be planned. This is the major advantage of this structure that they can be constructed prior to the excavation. A sequence of piles is installed at some spacing through marginally stable material or unstable soil mass or bed rock to safe depths so that these piles can hold back surface materials while deep or shallow excavations are initiated. Even in congested sites or close to existing structures, these are useful by preventing any side slope movement. Depending on the nature of slope materials and pattern of anticipated slide, the spacing of the piles is determined. The construction requires less manpower, but more costly, though the reliability of the technique is comparatively good. When the ground materials have poor stability, sheet pile walls with least pile space can be considered.

8.2.1.5 RCC diaphragm walls

A diaphragm wall is a deep structural unit that often acts as a supporting wall a diaphragm wall (D-wall) is a reinforced concrete structure often constructed in-situ panel by panel. Precast concrete components can also be used. In the basement market D-walls are often used on congested sites, close to existing structures where the excavation depth and ground conditions would prove problematic for piled walls. The stabilizing action of these walls is nearly similar to that of pile walls, though they are continuous in nature.

8.2.1.6 Concrete crib walls

A concrete crib wall consists of a network of concrete cribs, which includes solid frames enclosing hollow cells to be filled with stone pitching or creating natural vegetation (see Fig. 8). The hollow spaces are sometimes sprayed with shotcrete leaving holes in between for drainage. The size of the frames range from 200 mm to 600 m while the hollow spaces have sizes ranging from 5 to 10 times the width of the concrete frame. Generally, the frames are tied to the ground through suitably designed anchor bars at the intersection of frames. These walls provide effective surface protection measures against scouring, erosion and preventing surface weathering. Precast concrete crib walls or cast in place concrete walls can be constructed as part of crib work. In places where groundwater is present in appreciable quantity, these walls are more preferable as since they have good drainage provisions.

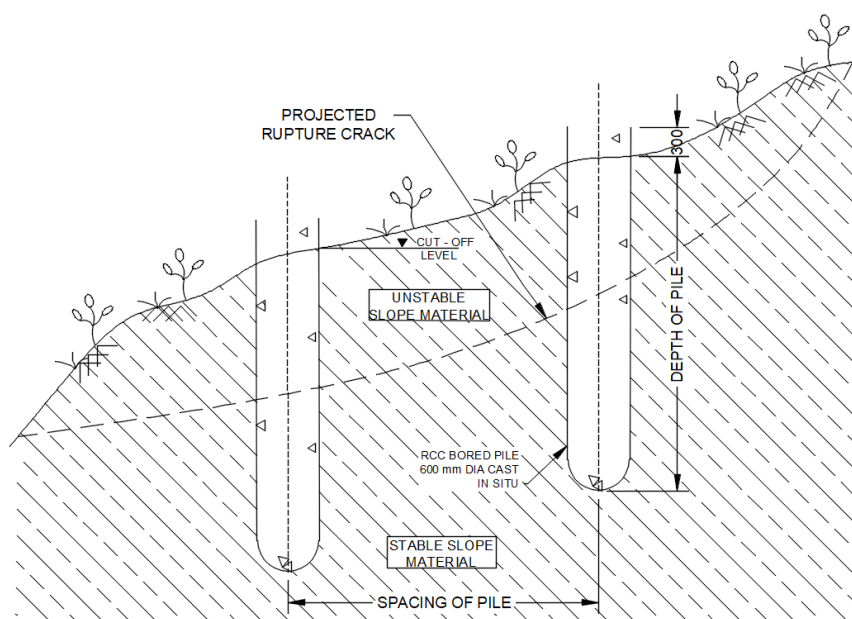

FIG. 7 SECTIONAL VIEW OF RESTRAINING PILES TO STABILIZE A ROTATIONAL FAILURE

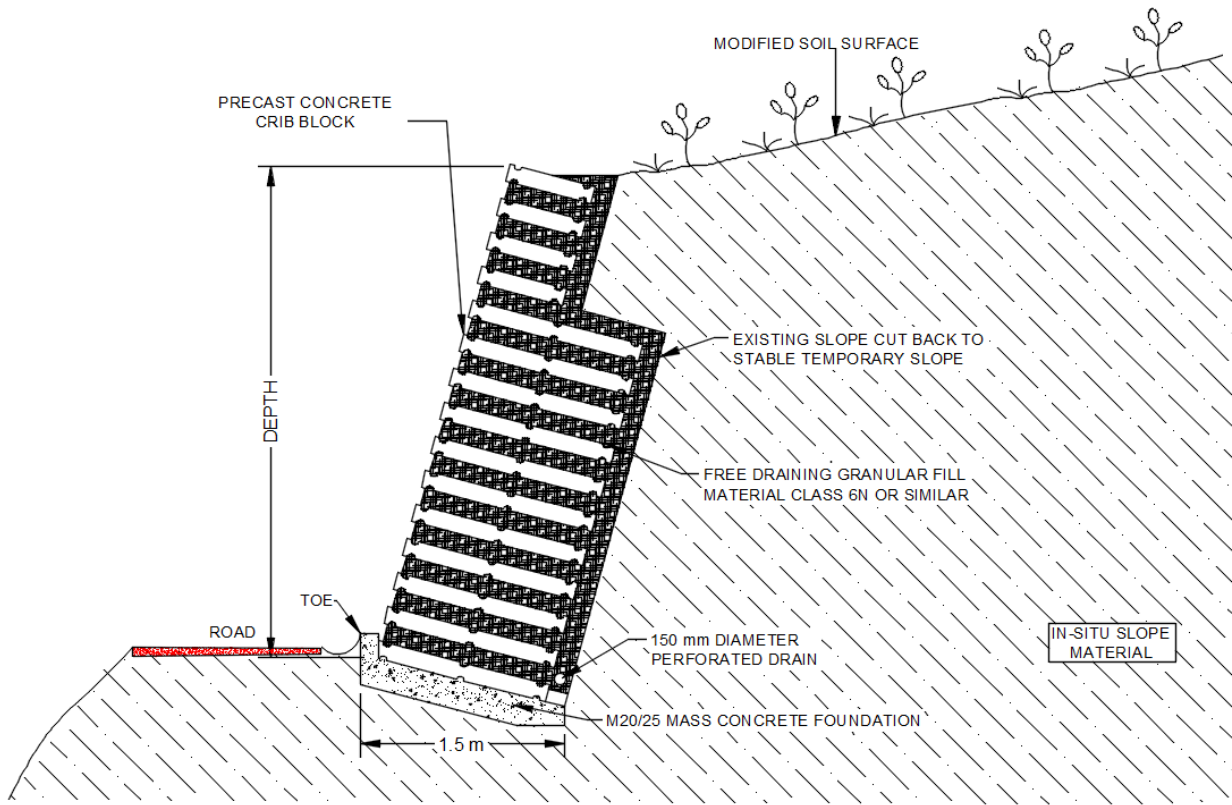

FIG. 8 CONCRETE CRIB WALL

8.2.1.7 Tie back wall

The tie back or anchored walls are constructed by tying an RCC wall through a system of deep, pre-stressed anchors so that the mobilized stresses from the slope are transferred to an area behind the unstable zone, where satisfactory resistance is likely to be available (see Fig. 9). These walls can be used for stabilizing unstable rock mass or soil mass on excavation at the toe. Even though the pre-stressed anchors, cables or rods, are preferred, post tensioned anchors also can be used depending upon the site conditions and the design. Once the excavation progresses down, the anchors are installed systematically till the final level. The free ends of the anchors are tied to the reinforcements of the concrete wall so that the wall develops adequate passive pressure to withstand the mobilized forces of the slopes.

8.2.2 Flexible Retaining Walls

The flexible retaining walls are often preferred as low height structures with poor foundation conditions or repeated water charged conditions. They are generally low-cost walls. The flexible retaining walls broadly include the following:

- a) Dry stone retaining wall;
- b) Banded stone masonry retaining wall;

- c) Gabion wall;
- d) Peripheral reinforced gabion wall;
- e) Timber crib wall; and
- f) Toe buttress wall.

8.2.2.1 Dry stone retaining wall

A dry stone masonry retaining wall is a gravity structure, which is constructed using locally available random rubble dry masonry stones (see Fig. 10). These walls are economical, but least durable and ductile structures. They are most susceptible to earthquake damages. However, they have excellent drainage provisions, which help to avoid pore pressure development.

These retaining walls are generally constructed to a maximum height of 4 m, though most of them do not exceed 2 m. The top thickness is usually kept at 0.6 m with 1 in 4 front batter and vertical back wall. Masonry courses should be normal to front face batter with a smooth finish and the back of the wall can be left with a rough finish. The stability of these walls will depend on the compressive strength of the foundation material. These walls are used only as a temporary measure as they may collapse during rains without offering much resistance. For further details, refer [see IS 14458 (Part 3)].

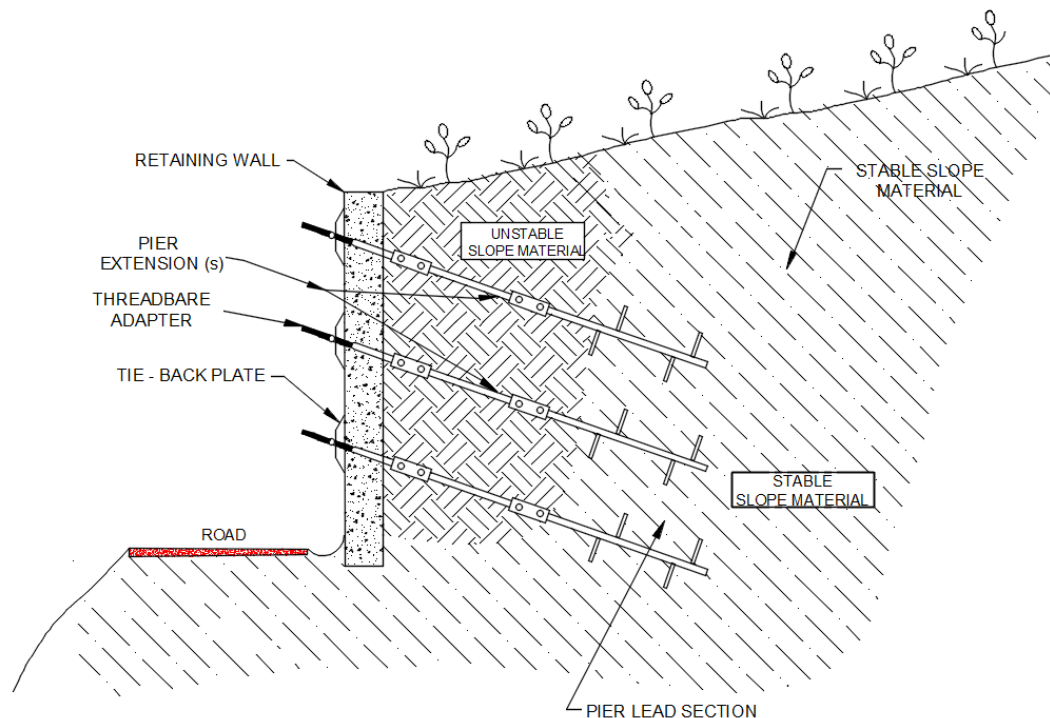

FIG. 9 TIE BACK WALL

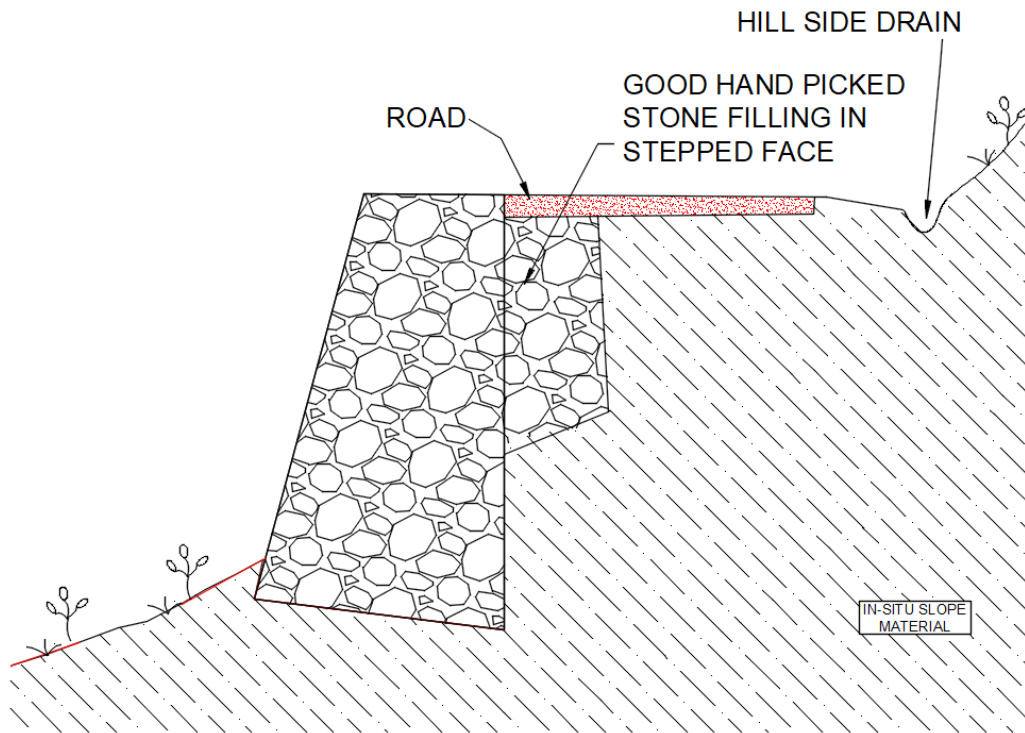

FIG. 10 DRY STONE RETAINING WALL

8.2.2.2 Banded stone masonry retaining wall

The banded stone masonry walls represent a slightly improved version of the dry stone masonry walls. Here, the drystone masonry type of wall is provided with 0.5 m wide mortar masonry bands generally at 1.5 m to 2 m intervals both in horizontal and vertical

directions. These masonry courses should be normal to front batter and the back of the wall should be finished rough (see Fig. 11). From the design criteria, though the strength of both the dry stone retaining wall and the banded stone masonry wall are considered more or less equal, the latter wall is much better due to periodic reinforcements

provided by masonry bands. However, both the walls may not bear any tension under stress. The stability of these walls will mostly depend on the compressive strength of the foundation soil and not on the compressive strength of the wall, which is usually quite adequate. For further details, refer [\[IS 14458 \(Part 4\)\]](#).

8.2.2.3 Gabion wall

The gabion walls are the most preferred in poor foundation or seepage conditions. They can not only take considerable differential settlement and some slope movement, but also can withstand large deformations without damage. Moreover, they allow free drainage of seepage water, as they have an open structure. The gabion walls provide effective toe support with their thick section and weight. Since the bulk of the material is locally available, they are also economical. A variety of cage sizes are used taking into account the availability of materials and to suit the terrain. However, the modules of $2\text{ m} \times 1\text{ m} \times 1\text{ m}$ with 2 m being parallel to the hill face is the commonly adopted gabions size in the hills, in which hand-picked big boulders/stones are filled (see [Fig. 12](#)). Hard, compact and blocky stones should be used. Weathered and tabular stones are not preferred. The top wires of the net are wrapped to bind the boulders intact. The entire work is carried out at the site itself taking into consideration the site conditions. The weight of the stones basically provides the stability to gabion walls. The height of these walls generally does not exceed 6 m , though most of them are 3 m to 4 m in height. For further details, please refer [see [IS 14458 \(Part 6\)](#)].

8.2.2.4 Peripheral reinforced gabion wall

A peripheral reinforced gabion (PRG) wall consists of systematically partitioned gabion units, tied to a series of pipes along the periphery and which are grouted to the ground below. In fact, it is the same as the ordinary gabion wall that is attached to the pipes on the periphery of boulder filled containers to increase their stability, durability and efficient functioning as compared to the conventional gabion walls (see [Fig. 13](#)). To create a PRG wall, a series of boulder filled wire fabric containers are tied together along their length in a direction generally perpendicular to the overall slope direction. These interconnected and variable size gabions filled with boulders are anchored to the ground below along the periphery with the help of grouted pipes. Hence, they can be considered as fairly rigid walls, which are highly pervious in nature. In addition to serving as a retaining wall for loose slope debris and soil, they are effectively used as protection walls to prevent bank erosion, parapet walls along the road, sea walls, channel lining, revetments and other such works. They are particularly useful for the grounds, characterized by loose materials, water logged conditions and even having shallow water conditions as the pipes can be anchored to deeper levels. In future, the PRG walls shall be effectively designed for many of the infrastructures like highways, railways, bridges, river front structures, bridge abutments, culvert protection works and many other uses. For further details, refer [\[IS 14458 \(Part 7\)\]](#).



FIG. 11 BANDED STONE MASONRY WALL

8.2.2.5 Timber crib wall

Timber crib is a gravity retaining wall system that consists of a cellular framework of interlocking treated timbers, which are filled with free draining random rubble masonry rock stones (see Fig. 14). Treated timbers are generally used to form cribs as interlocking precast units, which are aligned parallel to and at right angles to the line of the wall, in such a way to form a series of hollow boxes. The boxes are filled with locally available rock stones or selected granular material to form a retaining wall. These walls are more preferred in poor soil/talus slopes. The horizontal and perpendicular rods are driven into the soil at least one time the width of the crib wall. The wall provides stability to the slope by its own load and partly passing on to the foundation below.

These walls are generally preferred up to a height of

4 m to 5 m, though they can be constructed up to 9 m. For a height of 5 m, the width of the wall can be kept at 2.5 m with a front batter of 1 : 4 to 1 : 6. They are preferred on gentle or moderate slopes ($< 30^\circ$). These walls should be founded at least 0.5 m to 1.0 m into the ground for better performance. These walls also can take considerable differential settlement and some slope movement, in addition to withstanding fairly large deformations without cracking. Moreover, they allow free drainage of seepage water, as they have an open structure. The crib walls provide effective toe support with their thick section and weight. Since the bulk of the material is locally available, they are very economical. The life expectancy of a timber crib system depends on the nature of preservative chemicals used and generally has a certified design life varying from 15 years to more than 60 years.

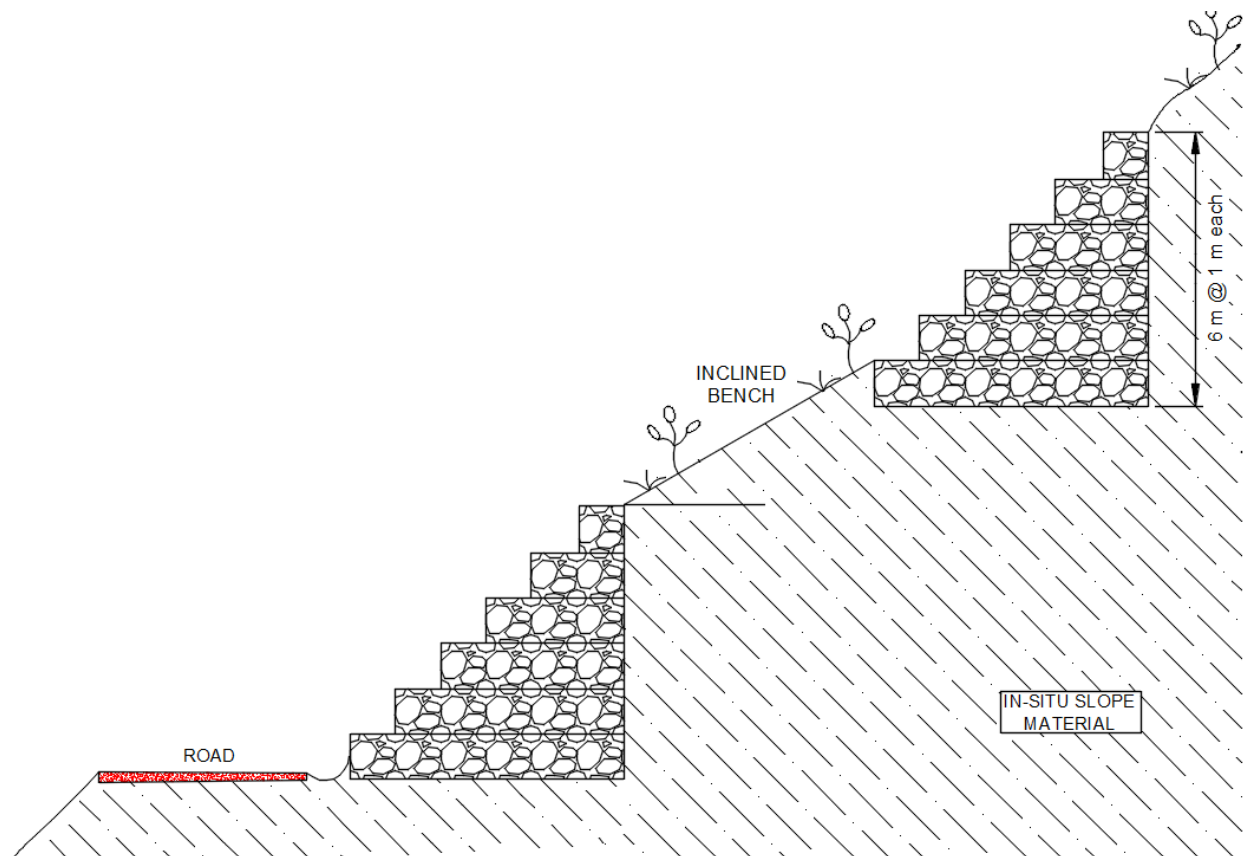

FIG. 12 SECTIONAL VIEW OF A TWO LEVEL GABION RETAINING WALL

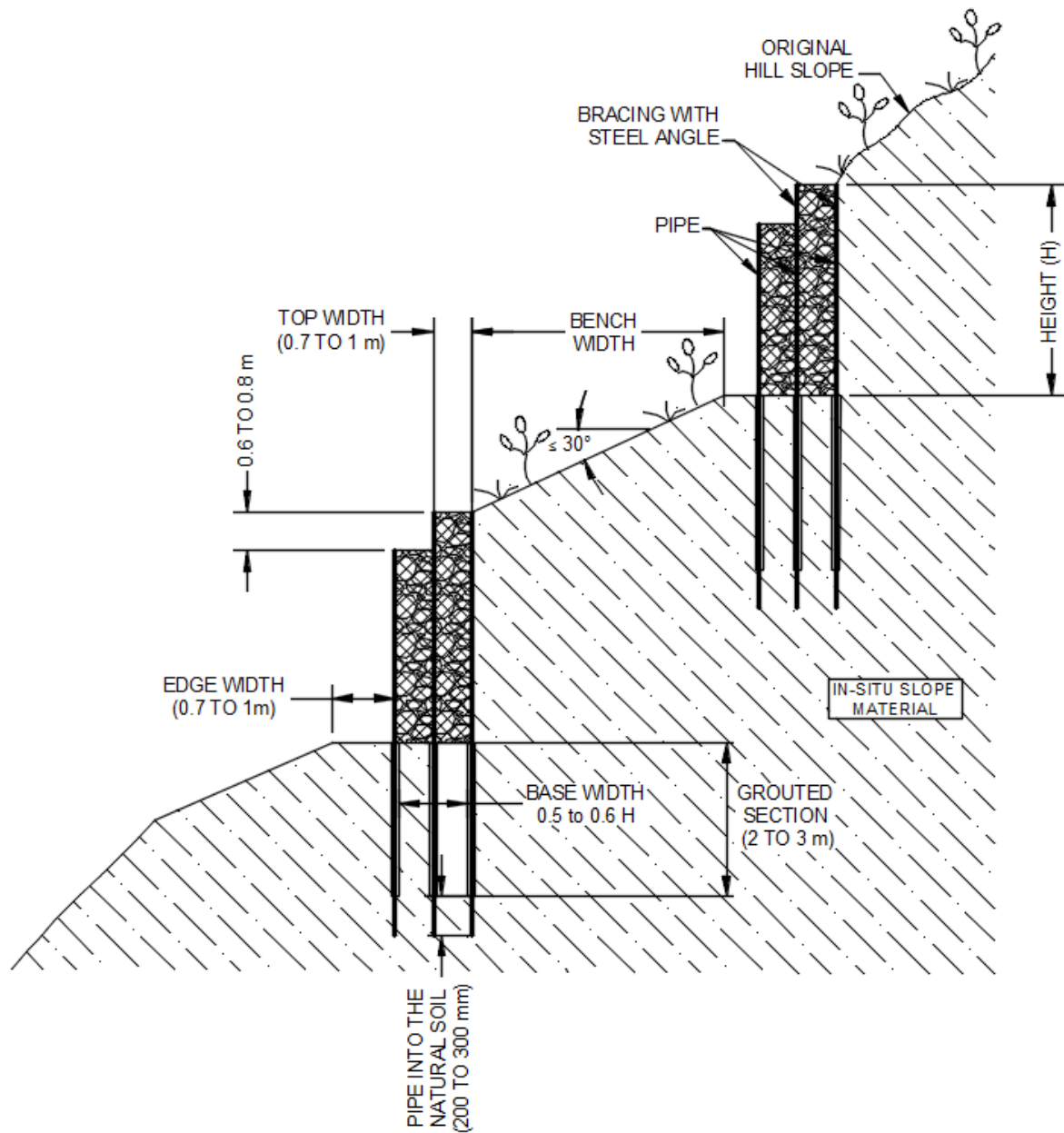

FIG. 13 SECTIONAL VIEW OF A TWO LEVEL PERIPHERAL REINFORCED GABION WALL (PRGW)



FIG. 14 A TIMBER CRIB RETAINING WALL

8.2.2.6 Toe buttress wall

These are basically restraining structures constructed in the toe area. The toe buttress walls made up of fluvial boulder rocks, quarried rock blocks, crushed rock blocks or other such pervious granular materials to provide counter-weight to the unstable slope materials (see Fig. 15). The dead weight so created at the toe will provide stability. The ability of such restraining structures to retain the slope mass is a function of resistance of the structure to:

- a) Overturning;
- b) Sliding at or below its base; and
- c) Shearing internally.

An overturning analysis is performed by treating the buttress as a gravity structure and resolving the force system to ensure the proper location of the resultant. Potential sliding at or below the base requires a similar analysis. The depth of the foundation should be adequate to overcome this problem. Internal shearing requires that the cross-sectional area should be checked to ensure that the toe structure does not fail by shear within itself.

These walls are preferred at the toe of slope cuts or terraces excavated for the construction of roads or buildings. In order to improve the stability of the cut slope, the total weight of slope material likely to fail is calculated and the design of the buttress wall is made to counter the total load of the slope materials in addition to pore pressures within the materials. Since free draining materials are used, pore pressure may be negligible. Hard and massive stones are used to provide maximum load.

8.3 Mitigating Water Related Problems

Water is a common and most potential causative factor in initiating landslides. Water may act as a triggering factor in some cases of landslide. Water is a potentially damaging factor on surface as well as subsurface. On surface it can cause erosion of slope as well as toe erosion along river courses leading to slope instabilities. Pore pressure development in sub-surface slope materials can effectively reduce their shear inherent strength and thereby inducing instability. Drainage is one of the most important and relatively cheaper methods to improve the stability of slopes by increasing the resisting forces. Some of the effective surface and subsurface drainage methods are discussed below.

8.3.1 Surface Drainage

Since uncontrolled surface water can inundate and

lead to pore water build-up of the existing and potential landslides in addition to surface erosion, it has to be trapped suitably and divert away from landslide locality. Two types of surface drains are often in use in this context.

8.3.1.1 Contour catch water drain

These drains are provided above the crown of the landslides or unstable slopes mainly to intercept surface run off water from up-hill side and divert suitably. Otherwise, the rainwater from higher levels may inundate the unstable slope leading to high pore water pressure and consequent instability. The size of this drain is dependent on the quantum of water to be trapped. However, a size of 0.5 m wide to 0.75 m deep to 0.75 m to 1.0 m is preferred in general. The bottom shall be kept curved as it helps to wash out the mud and debris accumulated inside, on its own under gravity flow. In any case, the trapped coarse waste materials have to be removed periodically and thereby allowing the drain to work efficiently. The drain wall on the hill side should follow the elevation of the hill slope in order to allow the flowing water on the slope to enter the drain freely. The valley side wall shall be slightly raised so that even the fast-flowing water can be effectively blocked. The drains are preferably made of RC concrete, though cement stone masonry walls are also used depending on the budget. These drains generally should have sufficient slope gradients of 1 in 20 at the bottom for efficient flow. If the drains are not properly maintained by periodically cleaning the materials blocking the drain, this may lead to concentrated leakage of water into the unstable zone causing severe damages.

8.3.1.2 Road side drain

Road side drains are provided on the hill side end of the road to drain out water from higher slopes as well as from the road surface. Road side drains are constructed with cement and random rubble stone masonry or RC concrete with curved bottom surface due to advantages indicated earlier (see Fig. 16). Though the size of the road side drain shall be designed according to the discharged amount of water, the generally preferred size could be 0.3 m wide and 0.2 m to 0.5 m deep. The bottom surface should be provided with a general gradient of 1 in 20 for efficient functioning. In case of deep drains, if they are covered with porous steel lids, it will help to increase the safety of the road and help to increase the width of the road as well. If the road gradients are steeper, the side drains shall be provided with stepped floor to break the velocity of water.

8.3.2 Sub-surface Drainage

Deep seated landslides and slope failures are often caused due to the presence of subsoil water within the slope materials resulting in high pore water pressures on failure planes. Sub-surface drainage helps to modify the seepage pattern within the soil or rock mass and thereby rendering the materials dry. Removal of sub-surface water tends to produce more stable conditions in following ways:

- a) Reduction in seepage forces and hence reducing driving forces; and
- b) Increase in shear strength.

Methods generally, used to accomplish sub-surface drainage include installation of inclined hole drainages, deep drainage galleries and systematic drainage holes in toe walls. For the provision of drainage holes in the retaining and breast walls, [see [IS 14458 \(Part 2\)](#) and [\(Part 5\)](#)] can be referred.

8.3.2.1 Inclined hole drainage

An inclined hole drainage simply refers to a drill

hole aligned at an effective down gradient of about 15° towards the valley side to drain out groundwater from the slope materials. A series of drill holes preferably of NX size (75 mm) to 100 mm diameter are drilled into the slopes and perforated pipes with solid bottom side shall be inserted into these pre-drilled holes to prevent collapse of the holes. The perforated pipes shall be wrapped with synthetic geotextile sheath to prevent entry of fine particles into the pipe through the perforations and cause clogging. They are installed at several levels with their free end located close to the open toe drains on the benches/roads so that the seepage water can be collected and taken away safely. This helps to lower the pore water pressure within the slope materials. Generally rigid PVC pipes with 2/3rd perforated/slotted portion are used leaving the bottom portion solid in order to prevent leakage below. A light weight drilling rig is required for making these boreholes to a depth of 3 m to 5 m. Water draining out from the holes should be safely collected into the lined catch water drain and finally discharged away.

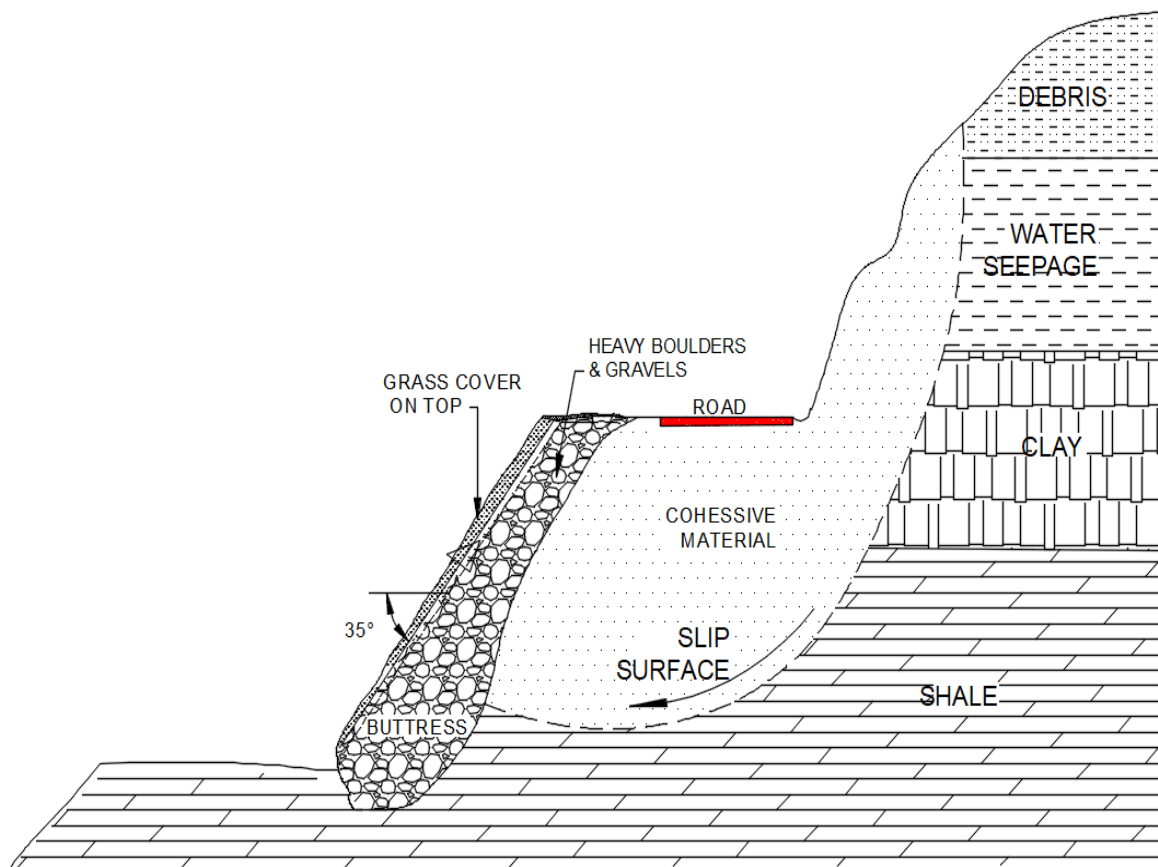

FIG. 15 TOE BUTTRESS WALL TO STABILIZE A CIRCULAR FAILURE FOR ROAD CONSTRUCTION

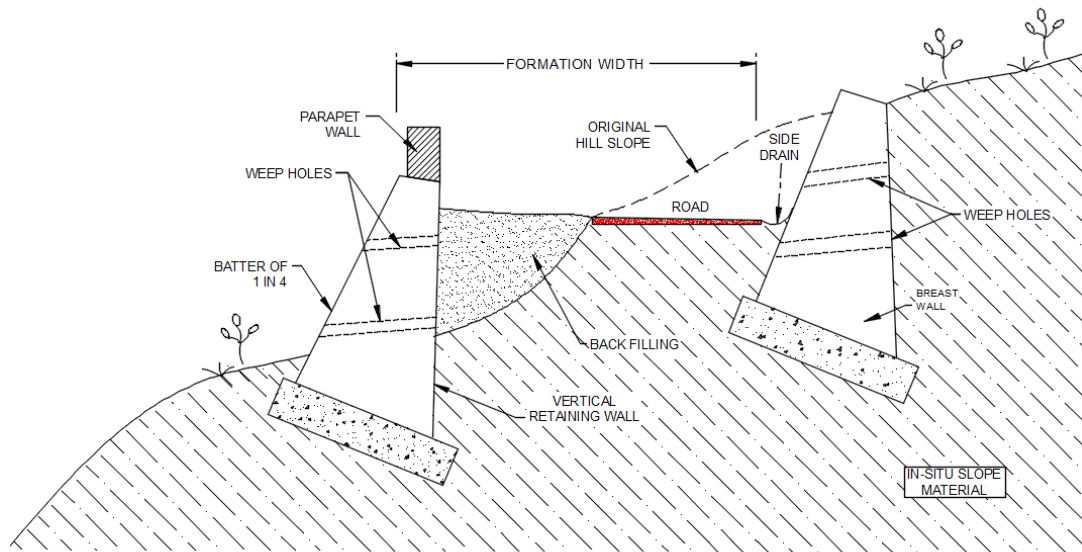

FIG. 16 ROAD SIDE U-SHAPED DRAIN

8.3.2.2 Deep tunnel drains

A deep tunnel drain can be used as an effective sub-surface drainage system if the seepage is excessive and which is a major reason to render the slope unstable. These drains are installed to intercept the water at depths of more than 5 m to 8 m. On potential slopes, where excessive water seepage is seen, deep D-shaped tunnels of preferably 1 m width and 1.5 m to 1.7 m height, are excavated perpendicular to the general slope surface for depths ranging from 5 m to 20 m depending on slope conditions. Steel ribs are erected immediately after the excavation at a closer spacing of 50 cm to 70 cm. The space between the ribs is protected with laggings made of cement stone blocks. The adjoining blocks are provided with an open space of 3 cm to 5 cm to enable subsurface seepage from the slope material above into the tunnel. If the adjoining slope materials are fine grained, the space can be protected with a fine wire mesh to prevent erosion and caving. In addition, a number of vertical and inclined drainage holes if required, can also be drilled inside the tunnel and inserted with perforated pipes. Moreover, the bottom surface of the tunnel is provided with mild gradients towards portal. As such, the seepage water collected on tunnel surface will flow towards the portal and get collected in a sump, from where it can be disposed of safely.

8.4 Increasing Shear Strength of Slope Materials

One of the most effective ways of tackling landslides is to increase the shearing resistance of

the slope materials by increasing the shear strength in the failure zone. This involves adopting different methods for two different types of slope materials namely:

- a) Soil and debris; and
- b) Cohesive rocks.

8.4.1 Increasing Shear Strength of Soil and Debris slope materials

Though there are many methods available to increase the resisting forces in slope materials such as reducing pore water pressure (see 8.3), the ones discussed below are particularly relevant for increasing shear strength of materials in the failure zone. These mainly include pile system as well as micro-piles and soil nails.

8.4.1.1 Pile system

In urban locations, when moderate to flat slopes are creeping along with the existing civil structures it is preferable to use large diameter piles, driven deeper into the slope in order to increase the shearing resistance of the soil mass. The individual piles should progress to deeper levels than the projected depth of the deepest failure surface of rupture in that location (see Fig. 7). In this system, the forces tending to cause movement are carefully studied and predicted and the additional restraint necessary to off-set the soil movement is provided by the closely spaced vertical piles. The cast in place piles shall be designed and placed across the moving surface to

resist full earth thrust imposed by the soil. Depending upon field conditions, one or more rows of piles and covering the entire width of unstable zone can be designed to counter the moving soil mass.

8.4.1.2 Micropiles

Micropiles are small diameter (typically less than 300 mm), drilled and grouted replacement piles that are typically reinforced. Micropiles are used for slope stabilization to provide the necessary restraining forces and to structurally support the slope. A micro-pile is constructed by drilling a borehole, placing reinforcements and grouting the hole. If stage grouting of these holes is desired, perforated steel pipes can be inserted inside the holes. Though minimum grout pressures are used for grouting depending on soil type, pressures gradually increase with the depth of grouting. Generally vertical micropiles are installed through the unstable slope to a designed depth below the failure surface in order to provide necessary resistance. A micro-pile is a friction pile, where the steel elements in the pile are bonded to the bearing rock or soil with the help of cement grout. These piles can be quickly installed in various kinds of ground conditions with the use of drilling equipment. Unlike a conventional pile, where large amount of water is used in an already unstable zone, pneumatic drilling can be employed with minimum water usage.

8.4.1.3 Soil nails

Soil nailing is a remedial construction measure to treat unstable natural soil slopes or unstable man-made slopes mainly to stabilize the over-steepened nature of the slopes. Soil nailing is an in-situ soil reinforcement technique used for enhancing the stability of soil slopes, retaining walls and excavations. It is the process of installing reinforcement with a designed spacing of steel bars or nails followed by grouting throughout the length in the existing ground using a top-down construction technique. The free end of the bars is provided with a bearing plate or head plate on the excavated steep surface. Later, shotcrete is applied on the wire mesh on the excavated face to provide a protective cover for the soil mass with suitable drainage provisions. Alternately, precast concrete panels can also be used as surface membrane. Using these basic principles, a number of automatized techniques are also in use. In order to release the seepage pressure, a number of drainage holes are provided on the steep face by inserting perforated galvanized iron (G.I.) pipes at a spacing of about 50 cm or more. These holes are inclined 10° to 15° down towards the valley side to discharge the seepage water easily under gravity.

8.4.2 Increasing Shear Strength of Rock Slopes

The rock mass is heterogeneous and discontinuous medium, composed essentially of solid blocks separated by discontinuities. The failure of hard rock masses is governed by the pre-existing discontinuities. The shear strength of the rock mass is largely dependent on the spacing and other properties of joints and determined in the field conditions. Rock bolts and rock anchors help to increase the shear strength by reinforcing the rock mass so that the stability increases. Many types of bars, bar bundles, cables, etc are in use. The active system of supports includes pre-tensioned bars or cables and the passive system involves un-tensioned bars for slope stability. The rock bolts and anchors are often used along with steel wire mesh spread on slope surface and bearing plates fixed on the free end of rods and holding the wire mesh tightly against the slope face.

8.4.2.1 Rock bolts

Rock bolts are commonly used to reinforce or stitch the surface or near-surface rock blocks that are apparently unstable in nature (see Fig. 17). The rock bolts help to stabilize the slope face by exerting a force, which compresses the joints and prevents from sliding of a recently excavated rock slope. These should be installed as soon as the excavation is completed in order to prevent distressing or loosening. The rock bolts like expansion shell bolts are not grouted and are tightened against the expansion shells at the end of the bar. The other types of rock bolts are often grouted along their entire length with cement or chemical agents for effective functioning. Though the rock bolts are in general non-tensioned, they may also be pre-tensioned if there is a possibility of slippage along smooth joint planes. The rock bolts are provided with bearing plates of adequate size at the free end. The rock bolts are generally installed normal to the slope surface, though the direction can also be changed slightly to the extent of 30° from normal taking into consideration attitude of discontinuities (refer see 8.4.2.2).

8.4.2.2 Rock anchors

The rock anchors travel to deeper levels and are used to support large masses of unstable rocks. Though there is no lower or upper limit of length of bars between bolts and anchors, the anchors generally travel to depths of more than 5 m and are grouted for the whole length of bar (see Fig. 18). Many types of anchors are in use such as pre-stressed single anchors, perfo-grout anchors and pre-stressed cable anchors. The pre-stressed single rock anchors can be comfortably designed up to 8 m to 10 m. The perfo-grout anchors generally

include a single anchor bar encased within a thin sheet of steel liner, which is uniformly perforated. The steel liner is attached to the anchor rod at the top and bottom as well as in between. The entire assembly is inserted into the predrilled hole and grouted. The grout freely travels through the perforations and creates a strong bond between the rock surface and the assembly as a whole. The length of anchors, thickness and bearing capacity of individual anchors as well as the number of anchors required on a rock face are dependent on the extent of instability and the deepest surface of rupture identified/inferred below the slope surface. It is mandatory that the individual anchors should extend beyond depth of unstable zone.

The pre-stressed cable anchors are advanced reinforcement devices used in integration of passive systems to counteract applied loads. These are highly flexible anchors, which can be designed for much deeper levels to support huge rock mass likely to get destabilized. The pre-stressed cable anchors include a cluster of cable anchors made of high-grade steel wires, which are generally placed inside a cylindrical duct made out of either metallic or high density poly ethylene (HDPE) plastic material. The whole assembly of the anchorage along with the cable is named as tendon. The entire assembly is lowered down into the pre-drill hole. The total length of cables is differentiated into free length and

fixed length. Initially, the fixed length is grouted well using packers. After the consolidation of the grout, the cables are tensioned to their design capacity. Because of this reason, these anchors are also termed as pre-stressed post tensioned grouted ground anchors. This process can be repeated for some time and later entire length of the anchor is grouted and sealed on the top.

The direction of any type of anchor is also an important factor in rock slope stability. The attempt here is to puncture as many discontinuities as possible so that more rock blocks can be supported. For that purpose, it is essential to observe the attitude of discontinuities on rock slopes and work out their preferred orientation with respect to slope direction using stereo net analysis. Though installing anchors in a direction normal to slope is the most preferred due to easy operation, a deviation of up to 30° from the normal to slope and in any direction to be decided from stereo net analysis may induce additional stability to the slope. In fact, based on stability analysis, the direction of anchor can be decided in such a way that the anchor penetrates as many discontinuities as possible and also travelling deeper than the surface of failure, the extent of unstable rock mass is estimated and accordingly the number and depth of anchors as well as their bearing capacity are designed.

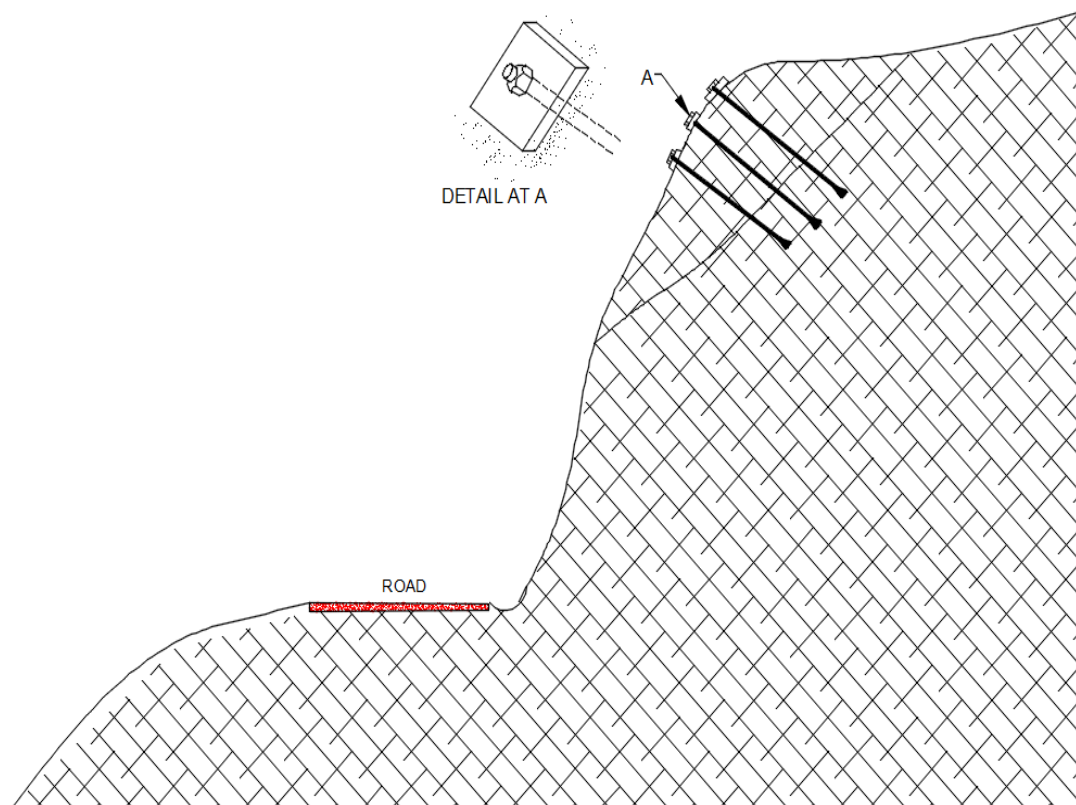

FIG. 17 ROCK BOLTS FOR STITCHING UNSTABLE ROCK BLOCKS CLOSE TO SURFACE

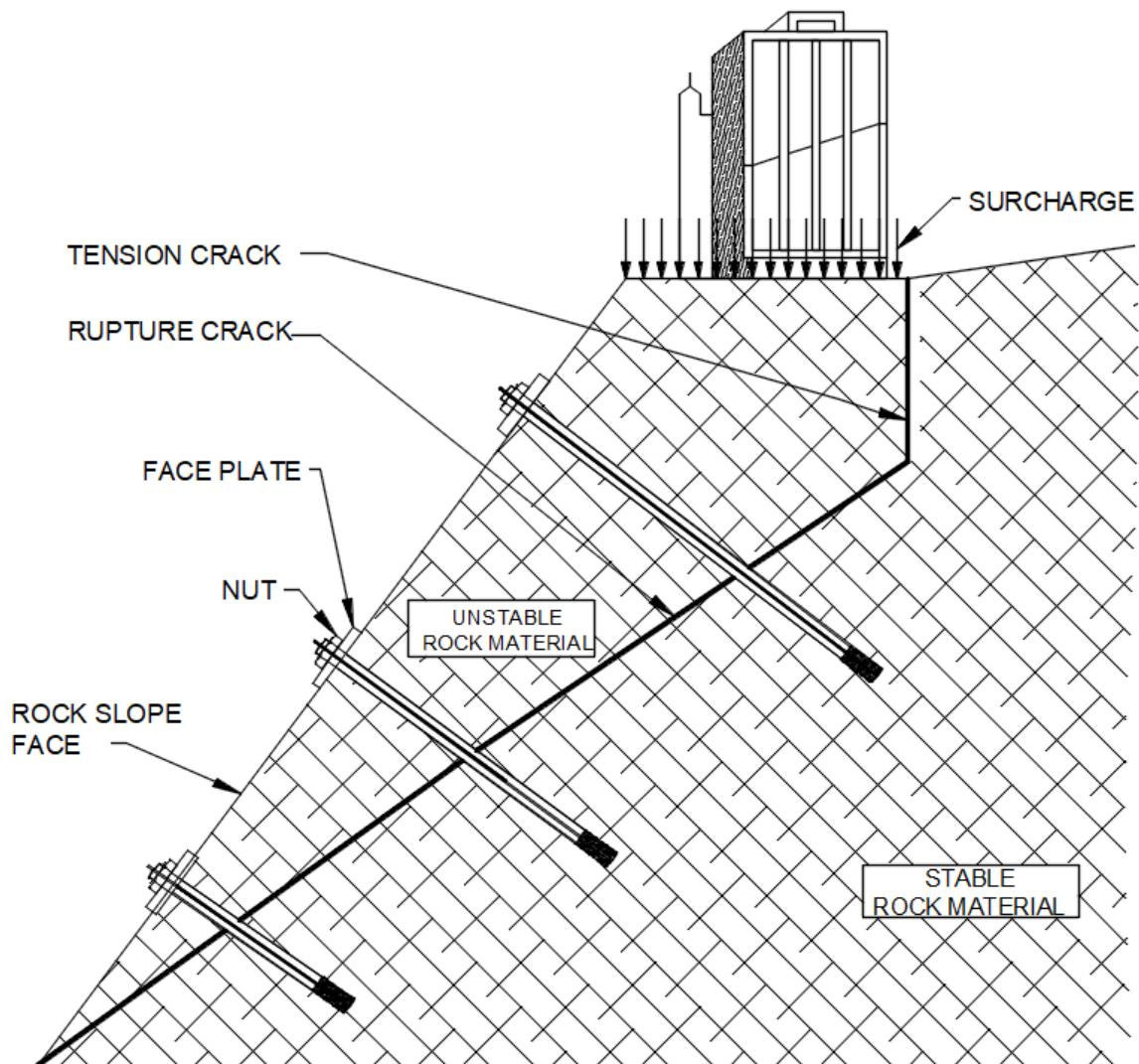

FIG. 18 ROCK ANCHORS FOR INCREASING SHEAR STRENGTH OF FAILURE ZONE AND ROCK MASS

8.5 Creating a Surface Protective Cover

Creating surface protective covers are in general, useful in case of shallow landslides for minimizing erosion and subsurface water percolation. In this context, biotechnical measures involving plantation and hydroseeding could be effectively implemented often along with geojute or netlon wire mesh for soil and debris slopes. In case of rock slopes, shotcreting on steel or polymer wire mesh is the preferred choice along with anchoring and other measures.

8.5.1 Surface Protective Cover for Soil and Debris Slopes

In case of degraded gentle earth slopes, broadcasting of seeds by hand or mechanical means in addition to plantation along with fertilizers may produce the required results. However, if the slopes are moderate to steep in nature, the above conventional methods

may not work effectively. Specialized techniques, such as wattling, mulching and crib structures can be adopted to provide mechanical support to the vegetation

The wattling is a method of breaking the length of slope into smaller parts by providing contour wattles at 3 m to 5 m intervals. The trenches of 30 cm wide and 1 m deep are dug following contour elevation and filled with brushwood bundles. On the downhill side of the trench and close to undisturbed ground, a series of posts of species, which sprout on planting are placed at 100 cm to 125 cm spacing. The trench is then filled back with dug up muck mixed with suitable fertilizers leaving about 10 cm gap from the normal ground level. The posts are then woven with locally available creepers/shrubs for a height of 20 cm to 30 cm above the ground. This highly pervious barriers reduce the velocity of run-off water on the slope and help to deposit soil and

debris. The posts gradually sprout and help in the stability.

The mulching is the process or practice of covering the ground to make more favourable conditions for plant growth. In this particular case, a protective cover of locally available grass is provided to safeguard the bare soil from the impacts top soil erosion (see [Fig. 19](#)). Later, locally available shrubs can be planted on the entire slope with suitable spacing to create more stability to the slope.

In some cases, where large areas with fairly steep slopes are to be covered and available funds are limited, hydro seeding is an efficient method. Here, a slurry of seeds, fertilizers, fertile soil, adhesive and water is sprayed on the slope for a thickness of 0.5 mm to 2 mm. On steep slopes, hydro seeding is more effective, when it is done on geotextiles laid ground. The geotextiles include jute geotextile (see [IS 14986](#)), coir geotextile (see [IS 15872](#)), polymer mesh (see [IS 17372](#) and [IS 17880](#)), etc.

8.5.2 Surface Protective Cover for Rock Slopes

Unlike soil, rock slopes consist of cohesive materials of solid blocks separated by discontinuities. These rock blocks may be more loose due to opening up of discontinuities close to surface on a blasted cut slope as compared to natural slopes. However, they tend to become more tight with depth. With time due to natural processes like surface erosion, weathering, subsurface seepage of water, freezing and other such processes cause more opening and dislodging of rock blocks. The best way to counter such process is to provide a protective cover by means of shotcreting. Here, shotcrete or sprayed concrete is conveyed through a hose and pneumatically projected at a high velocity on a surface, usually rock surface. The shotcrete is typically reinforced by conventional steel rods, steel mesh, or fibres placed just above the rock surface before spraying. This process helps to prevent weathering and spalling of rock surfaces and to provide surface reinforcement between blocks.

The concrete or mortar is designed to be sticky and resist flowing, so that the force of the jet compacts the mortar in place. Hence, it can be sprayed on any type or shape of surface, including vertical or overhang areas. Shotcrete helps to provide high compressive strength, good durability, water tightness and frost resistance to rock surface. Before shotcreting, open joints should be sealed well to provide a sound rock condition for better performance of shotcreted surface. However, the surface water seeping into ground at higher levels may exert pore pressure and cause deterioration of shotcrete. Hence the unfavourable groundwater just behind shotcrete should be drained safely. One way is to drill a series of drill holes on shotcreted surface to drain out the trapped subsurface water. However, its effectiveness is not very convincing as excessive seepage often leads to the damage of the shotcrete in the long run. The best way to achieve is to leave about 15 percent to 20 percent of total rock surface area with only steel wire mesh above without shotcreting. The non-shotcreted area should be uniformly distributed in a regular square pattern (see [Fig. 20](#)).

9 ROCK FALL PROTECTION MEASURES

Rock falls are common on steep to very steep rock slopes. Predicting specified unstable rock blocks on a steep slope face is not possible though rock blocks can be expected to fall suddenly from any part of the slope. Such loose rock falls are often reported in *Himalaya* and it is advisable to adopt suitable protection measures to counter the rock fall impacts.

Otherwise, the free-falling rock blocks may roll down and enter the adjoining the residential or commercial area and cause huge damages. These rock blocks can be arrested by constructing a series of catch pits with the help of concrete walls at different levels. Alternately, rock fall catch nets [[see \(IS/ISO 17745\)](#) and [\(IS/ISO 17746\)](#)], can be erected at different levels to intercept the falling blocks. The important caution about these measures is that the collected materials should be periodically removed to create more space for the future falling blocks.

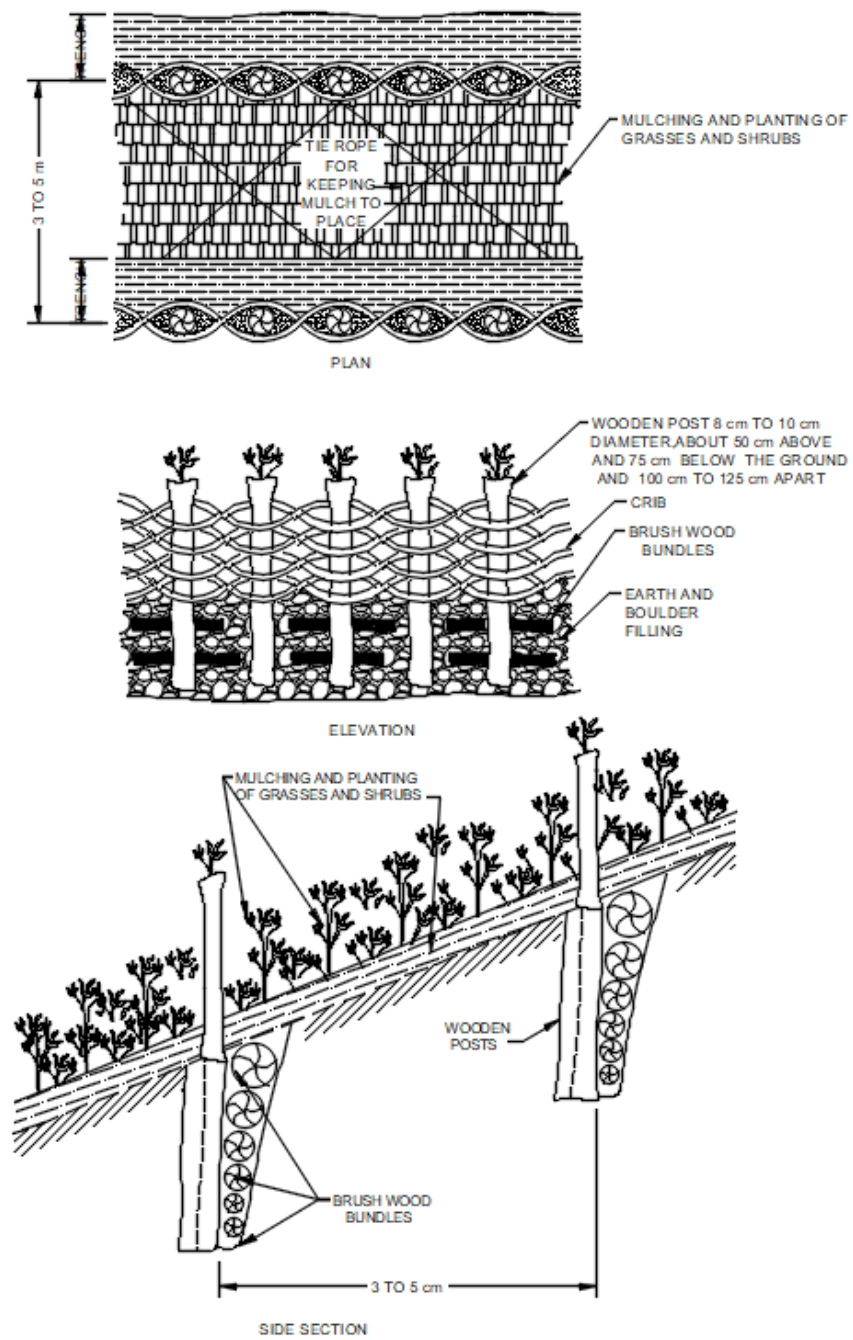

FIG. 19 WATTLE AND MULCHING TECHNIQUES FOR SLOPE STABILIZATION

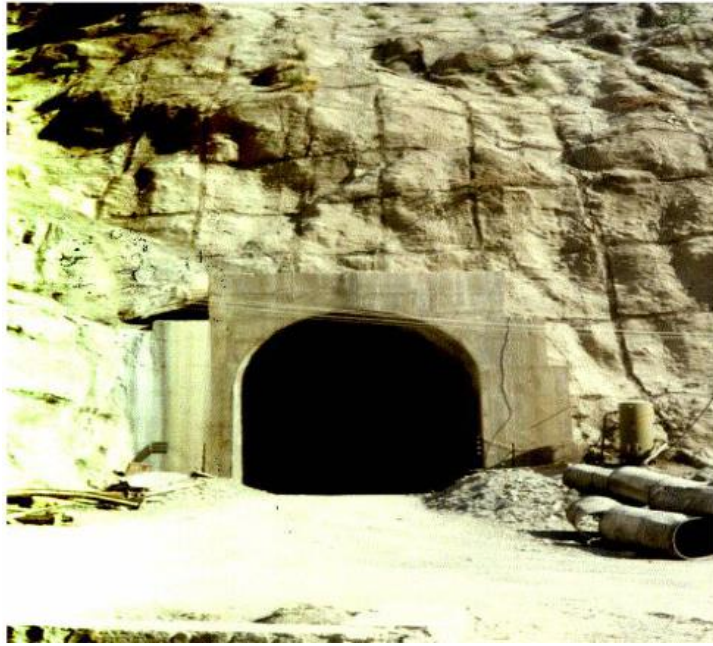

FIG. 20 SHOTCRETED ROCK SURFACE LEAVING 15 PERCENT SURFACE AREA FOR FREE DRAINAGE

ANNEX A

(Clause 2)

LIST OF REFERRED STANDARDS

<i>IS No.</i>	<i>Title</i>	<i>IS No.</i>	<i>Title</i>
IS 14458	Retaining wall for hill area — Guidelines:	IS 15872 : 2009	Application of coir geotextiles (coir woven <i>bhoovastra</i>) for rain water erosion control in roads, railway embankments and hill slopes — Guidelines
(Part 1) : 1998	Selection of type of wall		
(Part 2) : 1997	Design of retaining/breast walls		
(Part 3) : 1998	Construction of dry stone walls	IS 17162 : 2020	Preparation of landslide risk assessment maps in mountainous terrains — Guidelines
(Part 4) : 2018	Construction of banded dry stone masonry walls		
(Part 5) : 2018	Construction of cement stone masonry walls	IS 17163 : 2020	Site specific investigation and stability analysis of landslides — Guidelines
(Part 6) : 2020	Construction of gabion walls	IS 17372 : 2020	Geosynthetics — Polymeric strip/geostrip used as soil reinforcement in retaining structures — Specification
(Part 7) : 2022	Construction of peripheral reinforced gabion walls		
IS 14496	Preparation of landslide hazard zonation maps in mountainous terrains — Guidelines:	IS/ISO 17745 : 2016	Steel wire ring net panels — Definitions and specifications
(Part 1) : 2020	Meso-zonation	IS/ISO 17746 : 2016	Steel wire rope net panels and rolls — Definitions and specifications
(Part 2) : 1998	Macro-zonation		
IS 14986 : 2001	Guidelines for application of jute geotextile for rain water erosion control in road and railway embankments and hill slopes	IS 17880 : 2022	Geosynthetics — Synthetic polymer rope gabions for coastal and waterways protection — Specification

To access Indian Standards click on the link below:

https://www.services.bis.gov.in/php/BIS_2.0/bisconnect/knownyourstandards/Indian_standards/isdetails/

ANNEX B

(Foreword)

COMMITTEE COMPOSITION

Hill Area Development Engineering Sectional Committee, CED 56

<i>Organization</i>	<i>Representative(s)</i>
In Personal Capacity (<i>Flat No-802, S4 Tower, Godrej Prime Complex, Shell Colony, Chembur, Mumbai</i>)	DR R. ANBALAGAN (<i>Chairperson</i>)
Central Soil & Materials Research Station, New Delhi	DR MANISH GUPTA SHRI HARI DAS (<i>Alternate</i>)
Central Water Commission, New Delhi	DIRECTOR HCD SHRI SOMESH KUMAR (<i>Alternate</i>)
CSIR - Central Building Research Institute, Roorkee	SHRI AJAY CHAURASIA SHRI NAVEEN NISHANT (<i>Alternate I</i>) SHRI M. VINOTH (<i>Alternate II</i>)
CSIR - Central Institute of Mining & Fuel Research, Roorkee	DR J. K. MAHNOT DR ASHOK KUMAR SINGH (<i>Alternate</i>)
CSIR - Central Road Research Institute, New Delhi	DR PANKAJ GUPTA DR P. S. PRASAD (<i>Alternate</i>)
CSIR - National Environmental Engineering Research Institute, Nagpur	DR SHALINI DHYANI
G. B. Pant Institute of Himalayan Environment Development, Almora	SHRI KIREET KUMAR SHRI VAIBHAV EKNATH GOSAVI (<i>Alternate</i>)
Geological Survey of India, Kolkata	SHRI AKSHAYA KUMAR MISHRA SHRI DHRUBAJYOTI CHAKRABORTY (<i>Alternate</i>)
Indian Institute of Remote Sensing, Dehradun	DR RAJAT S. CHATTERJEE DR SHOVAN L. CHATTORAJ (<i>Alternate</i>)
Indian Institute of Technology, Indore	PROF NEELIMA SATYAM
Indian Institute of Technology, Roorkee	DR MAHENDRA SINGH DR N. K. SAMADHIYA (<i>Alternate I</i>) PROF AJANTA GOSWAMI (<i>Alternate II</i>)
Maccaferri Environmental Solutions Private Limited, Gurugram	SHRIMATI MINIMOL KORULLA SHRI RUDRA BUDHBHATTI (<i>Alternate</i>)
National Centre for Seismology, New Delhi	DR O. P. MISHRA DR H. S. MANDAL (<i>Alternate</i>)
National Disaster Management Authority, New Delhi	J.S. (MITIGATION) SHRI SAFI AHSAN RIZVI (<i>Alternate</i>)
National Institute of Hydrology, Roorkee	DR SUHAS KHOBRADE DR SURJEET SINGH (<i>Alternate</i>)
Rail Vikas Nigam Limited, New Delhi	SHRI SUMIT JAIN
THDC India Limited, Rishikesh	SHRI T. S. ROUTELA SHRI AJAY KUMAR (<i>Alternate</i>)
Wadia Institute of Himalayan Geology, Dehradun	DR VIKRAM GUPTA

<i>Organization</i>	<i>Representative(s)</i>
In Personal Capacity (<i>Flat No. 4123, Tower 4, ACE Golfshire, Sector - 150, Noida</i>)	DR R. K. GOEL
BIS Directorate General	SHRI DWAIPAYAN BHADRA, SCIENTIST 'E'/DIRECTOR AND HEAD (CIVIL ENGINEERING) [REPRESENTING DIRECTOR GENERAL (<i>Ex-officio</i>)]

Member Secretary
DR MANOJ KUMAR RAJAK
SCIENTIST 'D'/JOINT DIRECTOR
(CIVIL ENGINEERING), BIS

Bureau of Indian Standards

BIS is a statutory institution established under the *Bureau of Indian Standards Act, 2016* to promote harmonious development of the activities of standardization, marking and quality certification of goods and attending to connected matters in the country.

Copyright

BIS has the copyright of all its publications. No part of these publications may be reproduced in any form without the prior permission in writing of BIS. This does not preclude the free use, in the course of implementing the standard, of necessary details, such as symbols and sizes, type or grade designations. Enquiries relating to copyright be addressed to the Head (Publication & Sales), BIS.

Review of Indian Standards

Amendments are issued to standards as the need arises on the basis of comments. Standards are also reviewed periodically; a standard along with amendments is reaffirmed when such review indicates that no changes are needed; if the review indicates that changes are needed, it is taken up for revision. Users of Indian Standards should ascertain that they are in possession of the latest amendments or edition by referring to the website-www.bis.gov.in or www.standardsbis.in.

This Indian Standard has been developed from Doc No.: CED 56 (23292).

Amendments Issued Since Publication

Amend No.	Date of Issue	Text Affected

BUREAU OF INDIAN STANDARDS

Headquarters:

Manak Bhavan, 9 Bahadur Shah Zafar Marg, New Delhi 110002

Telephones: 2323 0131, 2323 3375, 2323 9402

Website: www.bis.gov.in

Regional Offices:

	Telephones
Central : 601/A, Konnectus Tower -1, 6 th Floor, DMRC Building, Bhavbhuti Marg, New Delhi 110002	{ 2323 7617
Eastern : 8 th Floor, Plot No 7/7 & 7/8, CP Block, Sector V, Salt Lake, Kolkata, West Bengal 700091	{ 2367 0012 2320 9474
Northern : Plot No. 4-A, Sector 27-B, Madhya Marg, Chandigarh 160019	{ 265 9930
Southern : C.I.T. Campus, IV Cross Road, Taramani, Chennai 600113	{ 2254 1442 2254 1216
Western : Manakalya, 4 th Floor, NTH Complex (W Sector), F-10, MIDC, Andheri (East), Mumbai 400093	{ 283 25838

Branches : AHMEDABAD, BENGALURU, BHOPAL, BHUBANESHWAR, CHANDIGARH, CHENNAI, COIMBATORE, DEHRADUN, DELHI, FARIDABAD, GHAZIABAD, GUWAHATI, HARYNA, HUBLI, HYDERABAD, JAIPUR, JAMMU & KASHMIR, JAMSHEDPUR, KOCHI, KOLKATA, LUCKNOW, MADURAI, MUMBAI, NAGPUR, NOIDA, PARWANOO, PATNA, PUNE, RAIPUR, RAJKOT, SURAT, VIJAYAWADA.