पूर्ण भरे बहाव वाले वृत्ताकार अनुप्रस्थ
काट वाले कंड्यूड में प्रविष्ट दाब विभेदी
युक्तियों द्वारा द्रव प्रवाह का मापन

भाग 1 सामान्य सिद्धांत एवं अपेक्षाएँ
(पहला पुनरीक्षण)

**Measurement of Fluid Flow by
Means of Pressure Differential
Devices Inserted In Circular Cross-
Section Conduits Running Full**

Part 1 : General Principles And Requirements
(*First Revision*)

ICS 17.120.10

© BIS 2018



भारतीय मानक ब्यूरो
BUREAU OF INDIAN STANDARDS
मानक भवन, 9 बहादुरशाह ज़फर मार्ग, नई दिल्ली-110002
MANAK BHAVAN, 9 BAHADUR SHAH ZAFAR MARG
NEW DELHI-110002
www.bis.gov.in www.standardsbis.in

NATIONAL FOREWORD

This Indian Standard (First Revision) which is identical with ISO 5167-1 : 2003 'Measurement of fluid flow by means of pressure differential devices inserted in circular cross-section conduits running full Part 1: General principles and requirements' issued by the International Organization for Standardization (ISO) was adopted by the Bureau of Indian Standards on the recommendation of the Hydrometry Sectional Committee and approval of the Water Resources Division Council.

This standard was first published in 1999 as identical with ISO 5167-1 : 1991 which covered measurement of fluid flow by orifice plates, nozzles and venture tubes inserted in circular cross-section conduits running full. The first revision of this standard is being done to align it with the latest version of ISO 5167-1 : 2003.

This standard is published in five parts. Other parts in this series are:

- Part 2 Orifice Plates
- Part 3 Nozzle and Venturi nozzles
- Part 4 Venturi tubes
- Part 5 Cone meters

The text of ISO Standard has been approved as suitable for publication as an Indian Standard without deviations. Certain conventions are, however, not identical to those used in Indian Standards. Attention is particularly drawn to the following:

- a) Wherever the words 'International Standard' appear referring to this standard, they should be read as 'Indian Standard'; and
- b) Comma (,) has been used as a decimal marker, while in Indian Standards, the current practice is to use a point (.) as the decimal marker.

In this adopted standard, reference appears to the following International Standards for which Indian Standards also exist. The corresponding Indian Standards, which are to be substituted in their respective places, are listed below along with their degree of equivalence for the editions indicated:

<i>International Standard</i>	<i>Corresponding Indian Standard</i>	<i>Degree of Equivalence</i>
ISO 5167-2 : 2003 Measurement of fluid flow by means of pressure differential devices inserted in circular cross-section conduits running full — Part 2 : Orifice plates	IS 14615 (Part 2) : 2018 Measurement of fluid flow by means of pressure differential devices inserted in circular cross-section conduits running full — Part 2 : Orifice plates	Identical
ISO 5167-3 : 2003 Measurement of fluid flow by means of pressure differential devices inserted in circular cross-section conduits running full — Part 3 : Nozzles and Venturi nozzles	IS 14615 (Part 3) : 2018 Measurement of fluid flow by means of pressure differential devices inserted in circular cross-section conduits running full — Part 3 : Nozzles and Venturi nozzles	Identical

(Continued on third cover)

*Indian Standard***MEASUREMENT OF FLUID FLOW BY MEANS
OF PRESSURE DIFFERENTIAL DEVICES INSERTED
IN CIRCULAR CROSS-SECTION CONDUITS
RUNNING FULL****PART 1 GENERAL PRINCIPLES AND REQUIREMENTS***(First Revision)***1 Scope**

This part of ISO 5167 defines terms and symbols and establishes the general principles for methods of measurement and computation of the flowrate of fluid flowing in a conduit by means of pressure differential devices (orifice plates, nozzles and Venturi tubes) when they are inserted into a circular cross-section conduit running full. This part of ISO 5167 also specifies the general requirements for methods of measurement, installation and determination of the uncertainty of the measurement of flowrate. It also defines the general specified limits of pipe size and Reynolds number for which these pressure differential devices are to be used.

ISO 5167 (all parts) is applicable only to flow that remains subsonic throughout the measuring section and where the fluid can be considered as single-phase. It is not applicable to the measurement of pulsating flow.

2 Normative references

The following referenced documents are indispensable for the application of this document. For dated references, only the edition cited applies. For undated references, the latest edition of the referenced document (including any amendments) applies.

ISO 4006:1991, *Measurement of fluid flow in closed conduits — Vocabulary and symbols*

ISO 5167-2:2003, *Measurement of fluid flow by means of pressure differential devices inserted in circular cross-section conduits running full — Part 2: Orifice plates*

ISO 5167-3:2003, *Measurement of fluid flow by means of pressure differential devices inserted in circular cross-section conduits running full — Part 3: Nozzles and Venturi nozzles*

ISO 5167-4:2003, *Measurement of fluid flow by means of pressure differential devices inserted in circular cross-section conduits running full — Part 4: Venturi tubes*

3 Terms and definitions

For the purposes of this document, the terms and definitions given in ISO 4006 and the following apply.

NOTE The following definitions are given only for terms used in some special sense or for terms for which it seems useful to emphasize the meaning.

3.1 Pressure measurement

3.1.1

wall pressure tapping

annular slot or circular hole drilled in the wall of a conduit in such a way that the edge of the hole is flush with the internal surface of the conduit

NOTE The pressure tapping is usually a circular hole but in certain cases may be an annular slot.

3.1.2

static pressure of a fluid flowing through a pipeline

p

pressure which can be measured by connecting a pressure-measuring device to a wall pressure tapping

NOTE Only the value of the absolute static pressure is considered in ISO 5167 (all parts).

3.1.3

differential pressure

Δp

difference between the (static) pressures measured at the wall pressure tapplings, one of which is on the upstream side and the other of which is on the downstream side of a primary device (or in the throat for a Venturi nozzle or a Venturi tube), inserted in a straight pipe through which flow occurs, when any difference in height between the upstream and downstream tapplings has been taken into account

NOTE In ISO 5167 (all parts) the term "differential pressure" is used only if the pressure tapplings are in the positions specified for each standard primary device.

3.1.4

pressure ratio

τ

ratio of the absolute (static) pressure at the downstream pressure tapping to the absolute (static) pressure at the upstream pressure tapping

3.2 Primary devices

3.2.1

orifice

throat

opening of minimum cross-sectional area of a primary device

NOTE Standard primary device orifices are circular and coaxial with the pipeline.

3.2.2

orifice plate

thin plate in which a circular opening has been machined

NOTE Standard orifice plates are described as "thin plate" and "with sharp square edge", because the thickness of the plate is small compared with the diameter of the measuring section and because the upstream edge of the orifice is sharp and square.

3.2.3

nozzle

device which consists of a convergent inlet connected to a cylindrical section generally called the "throat"

3.2.4

Venturi nozzle

device which consists of a convergent inlet which is a standardized ISA 1932 nozzle connected to a cylindrical part called the "throat" and an expanding section called the "divergent" which is conical

3.2.5

Venturi tube

device which consists of a convergent inlet which is conical connected to a cylindrical part called the “throat” and an expanding section called the “divergent” which is conical

3.2.6

diameter ratio

β

(of a primary device used in a given pipe) ratio of the diameter of the orifice or throat of the primary device to the internal diameter of the measuring pipe upstream of the primary device

NOTE However, when the primary device has a cylindrical section upstream, having the same diameter as that of the pipe (as in the case of the classical Venturi tube), the diameter ratio is the ratio of the throat diameter and the diameter of this cylindrical section at the plane of the upstream pressure tapings.

3.3 Flow

3.3.1

flowrate

rate of flow

q

mass or volume of fluid passing through the orifice (or throat) per unit time

3.3.1.1

mass flowrate

rate of mass flow

q_m

mass of fluid passing through the orifice (or throat) per unit time

3.3.1.2

volume flowrate

rate of volume flow

q_V

volume of fluid passing through the orifice (or throat) per unit time

NOTE In the case of volume flowrate, it is necessary to state the pressure and temperature at which the volume is referenced.

3.3.2

Reynolds number

Re

dimensionless parameter expressing the ratio between the inertia and viscous forces

3.3.2.1

pipe Reynolds number

Re_D

dimensionless parameter expressing the ratio between the inertia and viscous forces in the upstream pipe

$$Re_D = \frac{V_1 D}{\nu_1} = \frac{4q_m}{\pi \mu_1 D}$$

3.3.2.2**orifice or throat Reynolds number** Re_d

dimensionless parameter expressing the ratio between the inertia and viscous forces in the orifice or throat of the primary device

$$Re_d = \frac{Re_D}{\beta}$$

3.3.3**isentropic exponent** κ

ratio of the relative variation in pressure to the corresponding relative variation in density under elementary reversible adiabatic (isentropic) transformation conditions

NOTE 1 The isentropic exponent κ appears in the different formulae for the expansibility [expansion] factor ε and varies with the nature of the gas and with its temperature and pressure.

NOTE 2 There are many gases and vapours for which no values for κ have been published so far, particularly over a wide range of pressure and temperature. In such a case, for the purposes of ISO 5167 (all parts), the ratio of the specific heat capacity at constant pressure to the specific heat capacity at constant volume of ideal gases can be used in place of the isentropic exponent.

3.3.4**Joule Thomson coefficient**

isenthalpic temperature-pressure coefficient

 μ_{JT}

rate of change of temperature with respect to pressure at constant enthalpy:

$$\mu_{JT} = \left. \frac{\partial T}{\partial p} \right|_H$$

or

$$\mu_{JT} = \frac{R_u T^2}{p C_{m,p}} \left. \frac{\partial Z}{\partial T} \right|_p$$

where

T is the absolute temperature;

p is the static pressure of a fluid flowing through a pipeline;

H is the enthalpy;

R_u is the universal gas constant;

$C_{m,p}$ is the molar-heat capacity at constant pressure;

Z is the compressibility factor

NOTE The Joule Thomson coefficient varies with the nature of the gas and with its temperature and pressure and can be calculated.

3.3.5 discharge coefficient

C

coefficient, defined for an incompressible fluid flow, which relates the actual flowrate to the theoretical flowrate through a device, and is given by the formula for incompressible fluids

$$C = \frac{q_m \sqrt{1 - \beta^4}}{\frac{\pi}{4} d^2 \sqrt{2 \Delta p \rho_1}}$$

NOTE 1 Calibration of standard primary devices by means of incompressible fluids (liquids) shows that the discharge coefficient is dependent only on the Reynolds number for a given primary device in a given installation.

The numerical value of C is the same for different installations whenever such installations are geometrically similar and the flows are characterized by identical Reynolds numbers.

The equations for the numerical values of C given in ISO 5167 (all parts) are based on data determined experimentally.

The uncertainty in the value of C can be reduced by flow calibration in a suitable laboratory.

NOTE 2 The quantity $1/\sqrt{1 - \beta^4}$ is called the “velocity of approach factor”, and the product

$$C \frac{1}{\sqrt{1 - \beta^4}}$$

is called the “flow coefficient”.

3.3.6 expansibility [expansion] factor

ε

coefficient used to take into account the compressibility of the fluid

$$\varepsilon = \frac{q_m \sqrt{1 - \beta^4}}{\frac{\pi}{4} d^2 C \sqrt{2 \Delta p \rho_1}}$$

NOTE Calibration of a given primary device by means of a compressible fluid (gas) shows that the ratio

$$\frac{q_m \sqrt{1 - \beta^4}}{\frac{\pi}{4} d^2 \sqrt{2 \Delta p \rho_1}}$$

is dependent on the value of the Reynolds number as well as on the values of the pressure ratio and the isentropic exponent of the gas.

The method adopted for representing these variations consists of multiplying the discharge coefficient C of the primary device considered, as determined by direct calibration carried out with liquids for the same value of the Reynolds number, by the expansibility [expansion] factor ε .

The expansibility factor, ε , is equal to unity when the fluid is considered incompressible (liquid) and is less than unity when the fluid is compressible (gaseous).

This method is possible because experiments show that ε is practically independent of the Reynolds number and, for a given diameter ratio of a given primary device, ε only depends on the pressure ratio and the isentropic exponent.

The numerical values of ε for orifice plates given in ISO 5167-2 are based on data determined experimentally. For nozzles (see ISO 5167-3) and Venturi tubes (see ISO 5167-4) they are based on the thermodynamic general equation applied to isentropic expansion.

3.3.7

arithmetical mean deviation of the roughness profile

R_a

arithmetical mean deviation from the mean line of the profile being measured

NOTE 1 The mean line is such that the sum of the squares of the distances between the effective surface and the mean line is a minimum. In practice R_a can be measured with standard equipment for machined surfaces but can only be estimated for rougher surfaces of pipes. See also ISO 4288.

NOTE 2 For pipes, the uniform equivalent roughness k may also be used. This value can be determined experimentally (see 7.1.5) or taken from tables (see Annex B).

4 Symbols and subscripts

4.1 Symbols

Table 1 — Symbols

Symbol	Quantity	Dimension ^a	SI unit
C	Coefficient of discharge	dimensionless	—
$C_{m,p}$	Molar-heat capacity at constant pressure	$ML^2T^{-2}\Theta^{-1}mol^{-1}$	J/(mol·K)
d	Diameter of orifice (or throat) of primary device under working conditions	L	m
D	Upstream internal pipe diameter (or upstream diameter of a classical Venturi tube) under working conditions	L	m
H	Enthalpy	$ML^2T^{-2}mol^{-1}$	J/mol
k	Uniform equivalent roughness	L	m
K	Pressure loss coefficient (the ratio of the pressure loss to the dynamic pressure, $\rho v^2/2$)	dimensionless	—
l	Pressure tapping spacing	L	m
L	Relative pressure tapping spacing: $L = l/D$	dimensionless	—
p	Absolute static pressure of the fluid	$ML^{-1}T^{-2}$	Pa
q_m	Mass flowrate	MT^{-1}	kg/s
q_V	Volume flowrate	L^3T^{-1}	m ³ /s
R	Radius	L	m
R_a	Arithmetical mean deviation of the (roughness) profile	L	m
R_u	Universal gas constant	$ML^2T^{-2}\Theta^{-1}mol^{-1}$	J/(mol·K)
Re	Reynolds number	dimensionless	—
Re_D	Reynolds number referred to D	dimensionless	—
Re_d	Reynolds number referred to d	dimensionless	—
t	Temperature of the fluid	Θ	°C
T	Absolute (thermodynamic) temperature of the fluid	Θ	K
U'	Relative uncertainty	dimensionless	—

Table 1 (continued)

Symbol	Quantity	Dimension ^a	SI unit
V	Mean axial velocity of the fluid in the pipe	LT^{-1}	m/s
Z	Compressibility factor	dimensionless	—
β	Diameter ratio: $\beta = d/D$	dimensionless	—
γ	Ratio of specific heat capacities ^b	dimensionless	—
δ	Absolute uncertainty	c	c
Δp	Differential pressure	$ML^{-1}T^{-2}$	Pa
Δp_c	Pressure loss across a flow conditioner	$ML^{-1}T^{-2}$	Pa
$\Delta \varpi$	Pressure loss across a primary device	$ML^{-1}T^{-2}$	Pa
ε	Expansibility [expansion] factor	dimensionless	—
κ	Isentropic exponent ^b	dimensionless	—
λ	Friction factor	dimensionless	—
μ	Dynamic viscosity of the fluid	$ML^{-1}T^{-1}$	Pa·s
μ_{JT}	Joule Thomson coefficient	$M^{-1}LT^2\Theta$	K/Pa
ν	Kinematic viscosity of the fluid: $\nu = \mu/\rho$	L^2T^{-1}	m ² /s
ξ	Relative pressure loss (the ratio of the pressure loss to the differential pressure)	dimensionless	—
ρ	Density of the fluid	ML^{-3}	kg/m ³
τ	Pressure ratio: $\tau = p_2/p_1$	dimensionless	—
ϕ	Total angle of the divergent section	dimensionless	rad

^a M = mass, L = length, T = time, Θ = temperature

^b γ is the ratio of the specific heat capacity at constant pressure to the specific heat capacity at constant volume. For ideal gases, the ratio of the specific heat capacities and the isentropic exponent have the same value (see 3.3.3). These values depend on the nature of the gas.

^c The dimensions and units are those of the corresponding quantity.

4.2 Subscripts

Subscript	Meaning
1	At upstream tapping plane
2	At downstream tapping plane

5 Principle of the method of measurement and computation

5.1 Principle of the method of measurement

The principle of the method of measurement is based on the installation of a primary device (such as an orifice plate, a nozzle or a Venturi tube) into a pipeline in which a fluid is running full. The installation of the primary device causes a static pressure difference between the upstream side and the throat or downstream side of the device. The flowrate can be determined from the measured value of this pressure difference and from the knowledge of the characteristics of the flowing fluid as well as the circumstances under which the device is being used. It is assumed that the device is geometrically similar to one on which calibration has been carried out and that the conditions of use are the same (see ISO 5167-2, ISO 5167-3 or ISO 5167-4).

The mass flowrate can be determined, since it is related to the differential pressure within the uncertainty limits stated in ISO 5167, using Equation (1):

$$q_m = \frac{C}{\sqrt{1-\beta^4}} \varepsilon \frac{\pi}{4} d^2 \sqrt{2\Delta p \rho_1} \quad (1)$$

Similarly, the value of the volume flowrate can be calculated using Equation (2):

$$q_V = \frac{q_m}{\rho} \quad (2)$$

where ρ is the fluid density at the temperature and pressure for which the volume is stated.

5.2 Method of determination of the diameter ratio of the selected standard primary device

In practice, when determining the diameter ratio of a primary element to be installed in a given pipeline, C and ε used in Equation (1) are, in general, not known. Hence the following shall be selected a priori:

- the type of primary device to be used; and
- a flowrate and the corresponding value of the differential pressure.

The related values of q_m and Δp are then inserted in Equation (1), rewritten in the form

$$\frac{C\varepsilon\beta^2}{\sqrt{1-\beta^4}} = \frac{4q_m}{\pi D^2 \sqrt{2\Delta p \rho_1}}$$

in which the diameter ratio of the selected primary device can be determined by iteration (see Annex A).

5.3 Computation of flowrate

Computation of the flowrate, which is a purely arithmetic process, is effected by replacing the different terms on the right-hand side of Equation (1) by their numerical values.

Except for the case of Venturi tubes, C may be dependent on Re , which is itself dependent on q_m . In such cases the final value of C , and hence of q_m , has to be obtained by iteration. See Annex A for guidance regarding the choice of the iteration procedure and initial estimates.

The diameters d and D mentioned in the equations are the values of the diameters at the working conditions. Measurements taken at any other conditions should be corrected for any possible expansion or contraction of the primary device and the pipe due to the values of the temperature and pressure of the fluid during the measurement.

It is necessary to know the density and the viscosity of the fluid at working conditions. In the case of a compressible fluid, it is also necessary to know the isentropic exponent of the fluid at working conditions.

5.4 Determination of density, pressure and temperature

5.4.1 General

Any method of determining reliable values of the density, static pressure and temperature of the fluid is acceptable if it does not interfere with the distribution of the flow in any way at the cross-section where measurement is made.

5.4.2 Density

It is necessary to know the density of the fluid at the upstream pressure tapping; it can either be measured directly or be calculated from an appropriate equation of state from a knowledge of the absolute static pressure, absolute temperature and composition of the fluid at that location.

5.4.3 Static pressure

The static pressure of the fluid shall be measured by means of an individual pipe-wall pressure tapping, or several such tapplings interconnected, or by means of carrier ring tapplings if carrier ring tapplings are permitted for the measurement of differential pressure in that tapping plane for the particular primary device. (See 5.2 in ISO 5167-2:2003, 5.1.5, 5.2.5 or 5.3.3 in ISO 5167-3:2003 or 5.4 in ISO 5167-4:2003, as appropriate).

Where four pressure tapplings are connected together to give the pressure upstream, downstream or in the throat of the primary device, it is best that they should be connected together in a “triple-T” arrangement as shown in Figure 1. The “triple-T” arrangement is often used for measurement with Venturi tubes.

The static pressure tapping should be separate from the tapplings provided for measuring the differential pressure.

It is permissible to link simultaneously one pressure tapping with a differential pressure measuring device and a static pressure measuring device, provided that it is verified that this double connection does not lead to any distortion of the differential pressure measurement.

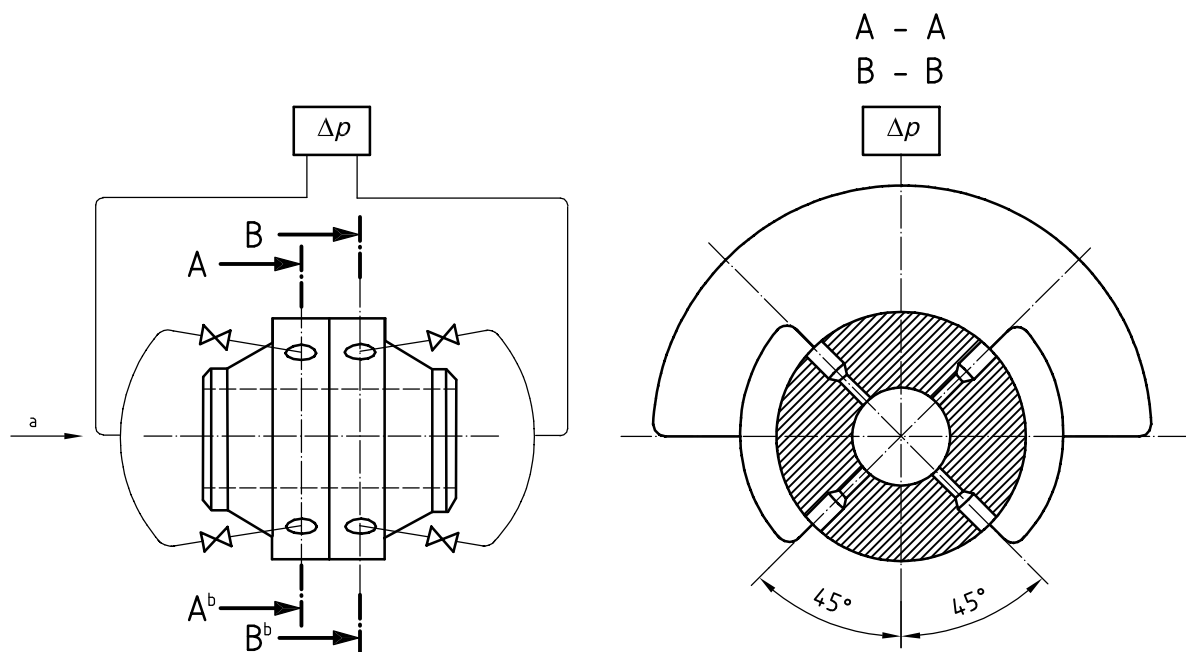

- a Flow
- b Section A-A (upstream) also typical for section B-B (downstream)

Figure 1 — “Triple-T” arrangement

5.4.4 Temperature

5.4.4.1 The temperature of the fluid shall preferably be measured downstream of the primary device. Temperature measurement requires particular care. The thermometer well or pocket shall take up as little space as possible. The distance between it and the primary device shall be at least equal to $5D$ (and at most $15D$ when the fluid is a gas) if the pocket is located downstream (in the case of a Venturi tube this distance is measured from the throat pressure tapping plane and the pocket shall also be at least $2D$ downstream from the downstream end of the diffuser section), and in accordance with the values given in ISO 5167-2, ISO 5167-3 or ISO 5167-4, depending on the primary device, if the pocket is located upstream.

Within the limits of application of this part of ISO 5167 it may generally be assumed that the downstream and upstream temperatures of the fluid are the same at the differential pressure tapings. However, if the fluid is a non-ideal gas and the highest accuracy is required and there is a large pressure loss between the upstream pressure tapping and the temperature location downstream of the primary device, then it is necessary to calculate the upstream temperature from the downstream temperature (measured at a distance of $5D$ to $15D$ from the primary device), assuming an isenthalpic expansion between the two points. To perform the calculation the pressure loss $\Delta\varpi$ should be calculated from 5.4 of ISO 5167-2:2003, 5.1.8, 5.2.8 or 5.3.6 of ISO 5167-3:2003 or 5.9 of ISO 5167-4:2003, depending on the primary device. Then the corresponding temperature drop from the upstream tapping to the downstream temperature location, ΔT , can be evaluated using the Joule Thomson coefficient, μ_{JT} , which is described in 3.3.4:

$$\Delta T = \mu_{JT} \Delta\varpi$$

NOTE 1 Experimental work^[1] has shown that this is an appropriate method for orifice plates. Further work would be required to check its correctness for other primary devices.

NOTE 2 Although an isenthalpic expansion is assumed between the upstream pressure tapping and the downstream temperature tapping, this is not inconsistent with there being an isentropic expansion between the upstream tapping and the vena contracta or throat.

NOTE 3 Measurement of temperature at a gas velocity in the pipe higher than approximately 50 m/s can lead to additional uncertainty associated with the temperature recovery factor.

5.4.4.2 The temperature of the primary device and that of the fluid upstream of the primary device are assumed to be the same (see 7.1.7).

6 General requirements for the measurements

6.1 Primary device

6.1.1 The primary device shall be manufactured, installed and used in accordance with the applicable part of ISO 5167.

When the manufacturing characteristics or conditions of use of the primary devices are outside the limits given in the applicable part of ISO 5167, it may be necessary to calibrate the primary device separately under the actual conditions of use.

6.1.2 The condition of the primary device shall be checked after each measurement or after each series of measurements, or at intervals close enough to each other so that conformity with the applicable part of ISO 5167 is maintained.

It should be noted that even apparently neutral fluids may form deposits or encrustations on primary devices. Resulting changes in the discharge coefficient which can occur over a period of time can lead to values outside the uncertainties given in the applicable part of ISO 5167.

6.1.3 The primary device shall be manufactured from material whose coefficient of thermal expansion is known.

6.2 Nature of the fluid

6.2.1 The fluid may be either compressible or considered as being incompressible.

6.2.2 The fluid shall be such that it can be considered as being physically and thermally homogeneous and single-phase. Colloidal solutions with a high degree of dispersion (such as milk), and only those solutions, are considered to behave as a single-phase fluid.

6.3 Flow conditions

6.3.1 ISO 5167 (all parts) does not provide for the measurement of pulsating flow, which is the subject of ISO/TR 3313. The flowrate shall be constant or, in practice, vary only slightly and slowly with time.

The flow is considered as not being pulsating^[2] when

$$\frac{\Delta p'_{\text{rms}}}{\overline{\Delta p}} \leq 0,10$$

where

$\overline{\Delta p}$ is the time-mean value of the differential pressure;

$\Delta p'$ is the fluctuating component of the differential pressure;

$\Delta p'_{\text{rms}}$ is the root mean square value of $\Delta p'$.

$\Delta p'_{\text{rms}}$ can only be measured accurately using a fast-response differential pressure sensor; moreover, the whole secondary system should conform to the design recommendations specified in ISO/TR 3313. It will not, however, normally be necessary to check that this condition is satisfied.

6.3.2 The uncertainties specified in the applicable part of ISO 5167 are valid only when there is no change of phase through the primary device. Increasing the bore or throat of the primary element will reduce the differential pressure, which may prevent a change of phase. For liquids the pressure at the throat shall not fall below the vapour pressure of the liquid (otherwise cavitation will result). For gases it is only necessary to calculate the temperature at the throat if the gas is in the vicinity of its dew-point; the temperature at the throat may be calculated assuming an isentropic expansion from the upstream conditions (the upstream temperature may need to be calculated in accordance with the equation in 5.4.4.1); the temperature and pressure in the throat should be such that the fluid is in the single-phase region.

6.3.3 If the fluid is a gas, the pressure ratio as defined in 3.1.4 shall be greater than or equal to 0,75.

7 Installation requirements

7.1 General

7.1.1 The method of measurement applies only to fluids flowing through a pipeline of circular cross-section.

7.1.2 The pipe shall run full at the measurement section.

7.1.3 The primary device shall be fitted between two straight sections of cylindrical pipe of constant diameter and of specified minimum lengths in which there is no obstruction or branch connection other than those specified in Clause 6 of ISO 5167-2:2003, ISO 5167-3:2003, or ISO 5167-4:2003, as appropriate, for particular primary devices.

The pipe is considered to be straight when the deviation from a straight line does not exceed 0,4 % over its length. Normally visual inspection is sufficient. Installation of flanges in the straight sections of pipe upstream and downstream of the primary device is allowed. The flanges shall be aligned in such a way that they do not introduce deviation from a straight line of more than 0,4 %. The minimum straight lengths of pipe conforming to the above requirement necessary for a particular installation, vary with the type and specification of the primary device and the nature of the pipe fittings involved.

7.1.4 The pipe bore shall be circular over the entire minimum length of straight pipe required. The cross-section may be taken to be circular if it appears so by visual inspection. The circularity of the outside of the pipe can be taken as a guide, except in the immediate vicinity ($2D$) of the primary device where special requirements shall apply according to the type of primary device used.

Seamed pipe may be used provided that the internal weld bead is parallel to the pipe axis throughout the entire length of the pipe required to satisfy the installation requirements for the primary device being used. Any weld bead shall not have a height greater than the permitted step in diameter. Unless an annular slot is used, the seam shall not be situated within any sector of $\pm 30^\circ$ centred on any individual pressure tapping to be used in conjunction with the primary device. If an annular slot is used, the location of the seam is not significant. If spirally wound pipe is used, then it shall be machined to a smooth bore.

7.1.5 The interior of the pipe shall be clean at all times. Dirt which can readily detach from the pipe shall be removed. Any metallic pipe defects such as metallic peeling shall be removed.

The acceptable value of pipe roughness depends on the primary device. In each case there are limits on the value of the arithmetical mean deviation of the roughness profile, R_a (see 5.3.1 of ISO 5167-2:2003, 5.1.2.9, 5.1.6.1, 5.2.2.6, 5.2.6.1, 5.3.1.9 and 5.3.4.1 of ISO 5167-3:2003 or 5.2.7 to 5.2.10 and 6.4.2 of ISO 5167-4:2003). The internal surface roughness of the pipe should be measured at approximately the same axial locations as those used to determine and verify the pipe internal diameter. A minimum of four roughness measurements shall be made to define the pipe internal surface roughness. In measuring R_a , an electronic-averaging-type surface roughness instrument which has a cut-off value of not less than 0,75 mm and a measuring range sufficient to measure the values of R_a found in the pipe should be used. The roughness can change with time as stated in 6.1.2, and this should be taken into account in establishing the frequency of cleaning the pipe or checking the value of R_a .

An approximate value of R_a may be obtained by assuming that R_a is equal to k/π , where k is the uniform equivalent roughness as given on the Moody diagram (see reference [3] in the Bibliography). The value of k is given directly by a pressure loss test of a sample length of pipe, using the Colebrook-White Equation (see 7.4.1.5) to calculate the value of k from the measured value of friction factor. Approximate values of k for different materials can also be obtained from the various tables given in reference literature, and Table B.1 gives values of k for a variety of materials.

7.1.6 The pipe may be provided with drain holes and/or vent holes to permit the removal of solid deposits and entrained fluids. However there shall be no flow through either drain holes or vent holes during the flow measurement process.

Drain and vent holes should not be located near to the primary device. Where it is not possible to conform to this, the diameter of these holes shall be less than $0,08D$ and they shall be located so that the minimum distance, measured on a straight line from each of these holes to a pressure tapping of the primary device on the same side as the holes, is greater than $0,5D$. The centreline of a pressure tapping and the centreline of a drain or vent hole shall be offset from each other by at least 30° relative to the axis of the pipe.

7.1.7 Insulation of the meter may be required in the case of temperature differences between the ambient temperature and the temperature of the flowing fluid which are significant given the uncertainty of measurement required. This is particularly true in the case of fluids being metered near their critical point where small temperature changes result in major density changes. It can be important at low flowrates, where heat transfer effects may cause distorted temperature profiles, for example, stratification of temperature layers from top to bottom. There may also be a change in the mean temperature value from the upstream to the downstream side of the meter run.

7.2 Minimum upstream and downstream straight lengths

7.2.1 The primary device shall be installed in the pipeline at a position such that the flow conditions immediately upstream of the primary device approximate to those of swirl-free, fully developed pipe flow. Conditions meeting this requirement are specified in 7.3.

7.2.2 The required minimum upstream and downstream straight lengths required for installation between various fittings and the primary device depend on the primary device. For some commonly used fittings as specified in Clause 6 of ISO 5167-2:2003, ISO 5167-3:2003 or ISO 5167-4:2003 the minimum straight lengths of pipe indicated may be used. However, a flow conditioner as described in 7.4 will permit the use of much shorter upstream pipe lengths. Such a flow conditioner shall be installed upstream of the primary device where sufficient straight length, to achieve the desired level of uncertainty, is not available.

7.3 General requirement for flow conditions at the primary device

7.3.1 Requirement

If the specified conditions given in Clause 6 of ISO 5167-2:2003, ISO 5167-3:2003 or ISO 5167-4:2003 cannot be met, the applicable part of ISO 5167 remains valid if the flow conditions at the primary device can be demonstrated to conform to swirl-free fully developed flow (as defined in 7.3.2 and 7.3.3) over the entire Reynolds number range of the flow measurement process.

7.3.2 Swirl-free conditions

Swirl-free conditions can be presumed to exist when the swirl angle at all points over the pipe cross-section is less than 2° .

7.3.3 Acceptable flow conditions

Acceptable velocity profile conditions can be presumed to exist when, at each point across the pipe cross-section, the ratio of the local axial velocity to the maximum axial velocity at the cross-section agrees to within 5 % with that which would be achieved in swirl-free flow at the same radial position at a cross-section located at the end of a very long straight length (over $100D$) of similar pipe (fully developed flow).

7.4 Flow conditioners (see also Annex C)

7.4.1 Compliance testing

7.4.1.1 Provided that a flow conditioner has passed the compliance test in 7.4.1.2 to 7.4.1.6 for a particular primary device, the flow conditioner may be used with the same type of primary device with any value of diameter ratio up to 0,67 downstream of any upstream fitting. Provided that the distance between the flow conditioner and the primary device and that between the upstream fitting and the flow conditioner are in accordance with 7.4.1.6 and the downstream straight length is in accordance with the requirements for the particular primary device (column 14 of Table 3 of ISO 5167-2:2003, column 12 of Table 3 of ISO 5167-3:2003 or the text in Table 1 of ISO 5167-4:2003), it is not necessary to increase the uncertainty of the discharge coefficient to take account of the installation.

7.4.1.2 Using a primary device of diameter ratio 0,67 the shift in discharge coefficient from that obtained in a long straight pipe shall be less than 0,23 % when the flow conditioner is installed in each of the following situations:

- a) in good flow conditions;
- b) downstream of a 50 % closed gate valve (or a D-shaped orifice plate);
- c) downstream of a device producing a high swirl (the device should produce a maximum swirl angle across the pipe of at least 24° at a distance $18D$ downstream of it or at least 20° at a distance $30D$ downstream of it). The swirl may be generated by a swirler or by other means. An example of a swirler is the unpatented Chevron Swirler given as Figure 2.

Upstream of the fittings in b) and c) there shall be a length of straight pipe which is sufficiently long that the primary device is not affected by any fittings upstream of those defined in b) or c).

NOTE These tests are required to establish that a flow conditioner

- does not have an adverse effect in good flow conditions,
- is effective in a highly asymmetric flow, and
- is effective in a highly swirling flow such as has been found downstream of a header.

The use of this test does not imply that flow measurement should be carried out downstream of a half-closed gate valve; flow control should be performed downstream of the primary device. For information regarding the work on which this test is based and the Chevron Swirler see References [4] and [5] in the Bibliography.

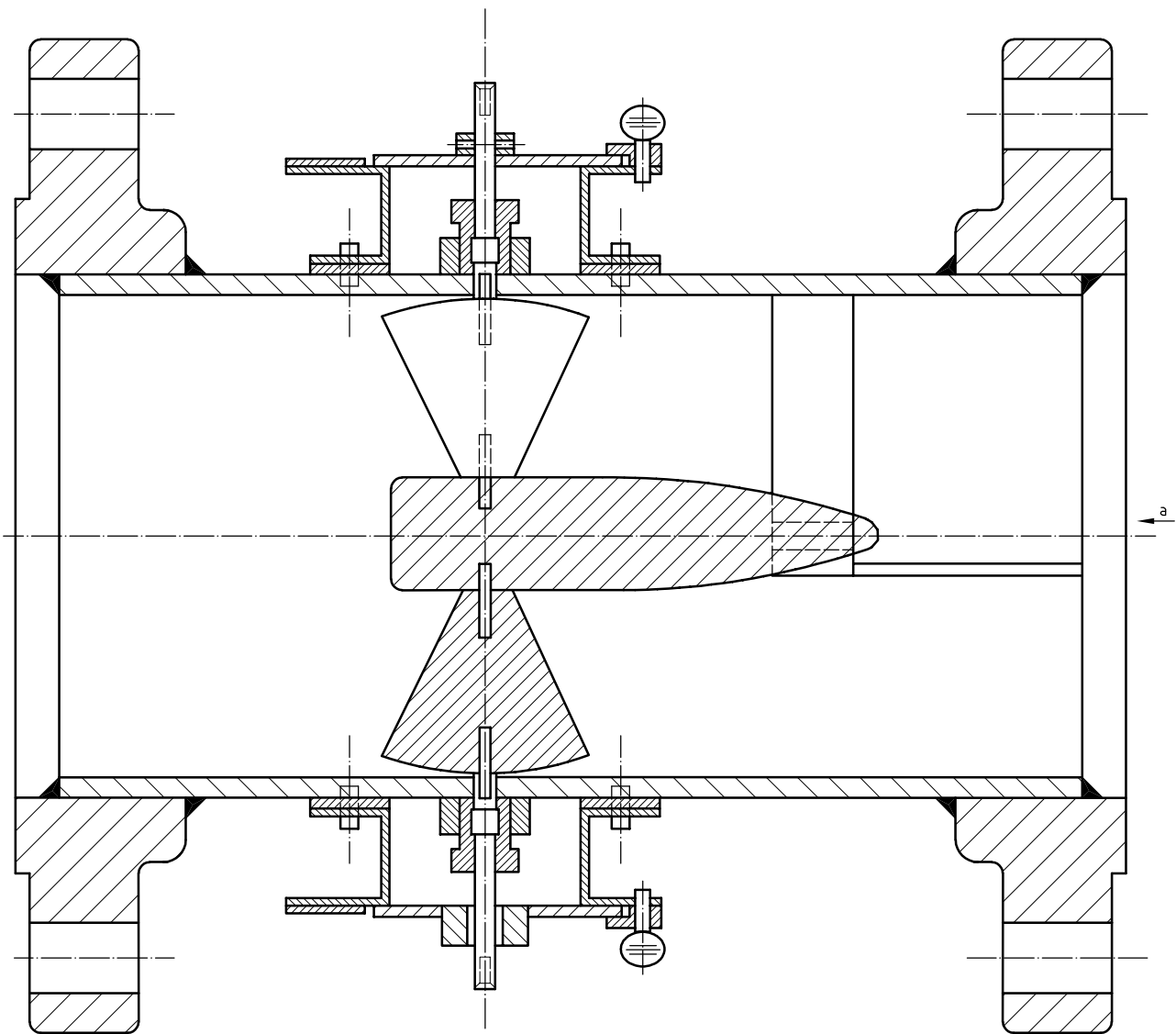

a Flow

Figure 2 — The Chevron Swirler

7.4.1.3 Using a primary device of diameter ratio 0,4, the shift in discharge coefficient from that obtained in a long straight pipe shall be less than 0,23 % when the flow conditioner is installed downstream of the same fitting as in 7.4.1.2 c).

NOTE This test is included in case there is still swirl downstream of the conditioner. The swirl can have more effect on the discharge coefficient for $\beta = 0,4$ than for $\beta = 0,67$.

7.4.1.4 To establish the acceptability of both the test facility and the primary devices with which the test is being conducted the baseline discharge coefficients for each primary device, as measured in a long straight pipe by the test facility, shall lie within the uncertainty limits of the discharge coefficient equation for an uncalibrated primary device as given by:

- 5.3.2.1 and 5.3.3.1 of ISO 5167-2:2003 for an orifice plate;
- 5.1.6.2 and 5.1.7.1 of ISO 5167-3:2003 for an ISA 1932 nozzle;
- 5.2.6.2 and 5.2.7.1 of ISO 5167-3:2003 for a long radius nozzle;
- 5.3.4.2 and 5.3.5.1 of ISO 5167-3:2003 for a Venturi nozzle;
- 5.5.2 and 5.7.1 of ISO 5167-4:2003 for a Venturi tube with an “as cast” convergent section;
- 5.5.3 and 5.7.2 of ISO 5167-4:2003 for a Venturi tube with a machined convergent section; or
- 5.5.4 and 5.7.3 of ISO 5167-4:2003 for a Venturi tube with a rough-welded sheet-iron convergent section.

For these tests, the test facility should first remove swirl and then have a sufficient length upstream of the primary device. For an orifice plate $70D$ length would be sufficient.

7.4.1.5 If the flow conditioner is to be acceptable at any Reynolds number then it is necessary to establish that it not only meets 7.4.1.2 and 7.4.1.3 at one Reynolds number, but that it meets a) or b) or c) from 7.4.1.2 at a second Reynolds number. If the two pipe Reynolds numbers are Re_{low} and Re_{high} then they shall meet the following criteria:

$$10^4 \leq Re_{low} \leq 10^6 \text{ and } Re_{high} \geq 10^6$$

and

$$\lambda(Re_{low}) - \lambda(Re_{high}) \geq 0,0036,$$

where λ is the pipe friction factor (see Reference [3] in the Bibliography), which may be obtained graphically from the Moody diagram or from the Colebrook-White equation

$$\frac{1}{\sqrt{\lambda}} = 1,74 - 2 \log_{10} \left(\frac{2k}{D} + \frac{18,7}{Re_D \sqrt{\lambda}} \right)$$

with k evaluated as πRa .

If it is only desired to use the flow conditioner for $Re_D > 3 \times 10^6$, it is sufficient to carry out the test in 7.4.1.2 at a single value of Re_D greater than 3×10^6 .

If the flow conditioner is to be acceptable for any pipe size, then it is necessary to establish that it not only meets 7.4.1.2 and 7.4.1.3 at one pipe size, but that it meets a) or b) or c) from 7.4.1.2 at a second pipe size. If the two pipe diameters are D_{small} and D_{large} then they shall meet the following criteria:

$$D_{small} \leq 110 \text{ mm (nominal 4 in) and } D_{large} \geq 190 \text{ mm (nominal 8 in).}$$

NOTE 1 The requirements on friction factor are determined in order that for an orifice plate, the velocity profile may change sufficiently that the discharge coefficient changes by at least twice the maximum permitted shift in discharge coefficient due to installation. From References [6] and [7] of the Bibliography, the effect of changes in friction factor is given by

$$\Delta C = 3,134\beta^{3,5}\Delta\lambda$$

Taking C equal to 0,6 and the minimum required change in C as $1,26\beta - 0,384$ % for $\beta \geq 0,67$ gives

$$\Delta\lambda \geq \frac{0,002\ 41\beta - 0,000\ 735}{\beta^{3,5}}$$

NOTE 2 Although for a nozzle the effect of $\Delta\lambda$ on C will be different from its effect on an orifice plate, the required values of Reynolds number for the compliance test still appear to be appropriate.

Since only a small range of Reynolds number is permitted in ISO 5167-2 or ISO 5167-3 for respectively a Venturi nozzle or Venturi tube, a flow conditioner will be acceptable over this range provided that it has passed the compliance test at a single Reynolds number.

7.4.1.6 The range of distances between the flow conditioner and the primary device and that between the upstream fitting and the flow conditioner which are used in the tests will determine the acceptable ranges of distances when the flowmeter is used. The distances shall be expressed in terms of numbers of pipe diameters.

7.4.1.7 If it is desired to carry out compliance testing for a flow conditioner for use up to a value of β which is greater than 0,67, then first it shall be shown to meet 7.4.1.2 to 7.4.1.5. Then the test described in 7.4.1.2, 7.4.1.4 and 7.4.1.5 shall be carried out at the maximum value of β over which the conditioner is to be used, β_{\max} . The permitted shift in discharge coefficient is increased to $(0,63\beta_{\max} - 0,192)$ %. In the case of 7.4.1.5.

$$\lambda(Re_{\text{low}}) - \lambda(Re_{\text{high}}) \geq \frac{0,002\ 41\beta_{\max} - 0,000\ 735}{\beta_{\max}^{3,5}}$$

Then, provided that the conditioner meets the compliance test in all the above tests, it has passed the compliance test for $\beta \leq \beta_{\max}$. The acceptable ranges of distances between the flow conditioner and the primary device and between the upstream fitting and the flow conditioner are determined as in 7.4.1.6.

7.4.2 Specific test

If a compliance test has not been carried out to permit the use of a flow conditioner downstream of any upstream fitting it may be necessary to carry out a specific flow test. The test will be deemed satisfactory if a test of that installation shows that the shift in discharge coefficient from that obtained in a long straight pipe is less than 0,23 %. The permitted shift in discharge coefficient can be increased to $(0,63\beta - 0,192)$ % for $0,67 < \beta \leq 0,75$ (or $0,67 < \beta \leq 0,8$ in the case of a nozzle or $0,67 < \beta \leq 0,775$ in the case of a Venturi nozzle). In this situation, it is not necessary to increase the uncertainty of the discharge coefficient to take account of the installation.

8 Uncertainties on the measurement of flowrate

NOTE More comprehensive information for calculation of the uncertainty of a measurement of flowrate, together with an example, is given in ISO/TR 5168.

8.1 Definition of uncertainty

8.1.1 For the purposes of ISO 5167 (all parts) the uncertainty is defined as an interval about the result of a measurement that may be expected to encompass approximately 95 % of the distribution of values that could reasonably be attributed to the measurand.

8.1.2 The uncertainty on the measurement of the flowrate shall be calculated and given under this name whenever a measurement is claimed to be in conformity with the applicable part of ISO 5167.

8.1.3 The uncertainty can be expressed in absolute or relative terms and the result of the flow measurement can then be given in any one of the following forms:

- flowrate = $q \pm \delta q$
- flowrate = $q(1 \pm U'_q)$
- flowrate = q within $(100U'_q) \%$

where the uncertainty δq shall have the same dimensions as q while $U'_q = \delta q/q$ shall be dimensionless.

8.1.4 For convenience a distinction is made between the uncertainties linked to measurements made by the user and those linked to quantities specified in the applicable part of ISO 5167. The latter uncertainties are on the discharge coefficient and the expansibility [expansion] factor; they give the minimum uncertainty with which the measurement is unavoidably tainted, since the user has no control over these values. They occur because small variations in the geometry of the device are allowed and because the investigations on which the values have been based could not be made under “ideal” conditions, nor without some uncertainty.

8.2 Practical computation of the uncertainty

8.2.1 Component uncertainties

From Equation (1), the computation of the mass flowrate q_m is given by:

$$q_m = C \varepsilon \frac{\pi}{4} d^2 \frac{\sqrt{2\Delta p \rho_1}}{\sqrt{1 - \beta^4}}$$

In fact, the various quantities which appear on the right-hand side of this equation are not independent, so that it is not correct to compute the uncertainty of q_m directly from the uncertainties of these quantities.

For example, C is a function of d , D , V_1 , v_1 and ρ_1 , and ε is a function of d , D , Δp , p_1 and κ .

8.2.1.1 However, it is sufficient, for most practical purposes, to assume that the uncertainties of C , ε , d , Δp and ρ_1 are independent of each other.

8.2.1.2 A practical working formula for δq_m can then be derived, which takes account of the interdependence of C on d and D which enters into the calculation as a consequence of the dependence of C on β . Note that C may also be dependent on the Reynolds number Re_D . However, the deviations of C due to these influences are of a second order and are included in the uncertainty on C .

Similarly, the deviations of ε which are due to uncertainties in the value of β , the pressure ratio and the isentropic exponent are also of a second order and are included in the uncertainty on ε . The contribution to the uncertainty due to the covariance terms may be considered to be negligible.

8.2.1.3 The uncertainties which shall be included in a practical working formula for δq_m are therefore those of the quantities C , ε , d , D , Δp and ρ_1 .

8.2.2 Practical working formula

8.2.2.1 The practical working formula for the uncertainty, δq_m , of the mass flowrate is given by Equation (3) as follows:

$$\frac{\delta q_m}{q_m} = \sqrt{\left(\frac{\delta C}{C}\right)^2 + \left(\frac{\delta \varepsilon}{\varepsilon}\right)^2 + \left(\frac{2\beta^4}{1-\beta^4}\right)^2 \left(\frac{\delta D}{D}\right)^2 + \left(\frac{2}{1-\beta^4}\right)^2 \left(\frac{\delta d}{d}\right)^2 + \frac{1}{4} \left(\frac{\delta \Delta p}{\Delta p}\right)^2 + \frac{1}{4} \left(\frac{\delta \rho_1}{\rho_1}\right)^2} \quad (3)$$

In Equation (3) some of the uncertainties, such as those on the discharge coefficient and expansibility [expansion] factor, are given in 8.2.2.2 and 8.2.2.3, while others have to be determined by the user (see 8.2.2.4 and 8.2.2.5).

8.2.2.2 In Equation (3), the values of $\delta C/C$ and of $\delta \varepsilon/\varepsilon$ shall be taken from the applicable part of ISO 5167.

8.2.2.3 When the straight lengths are such that an additional uncertainty of 0,5 % is to be considered, this additional uncertainty shall be added arithmetically in accordance with the requirements given in 6.2.4 of ISO 5167-2:2003, ISO 5167-3:2003 and ISO 5167-4:2003, and not quadratically as with the other uncertainties in the formula above. Other additional uncertainties (see 6.4.4 and 6.5.3 of ISO 5167-2:2003 and 6.4.4 of ISO 5167-3:2003) shall be added arithmetically in the same way.

8.2.2.4 In Equation (3), the maximum values of $\delta D/D$ and $\delta d/d$, which can be derived from the specifications given in 6.4.1 of ISO 5167-2:2003, 6.4.1 of ISO 5167-3:2003 and 5.2.2 of ISO 5167-4:2003, and 5.1.8 of ISO 5167-2:2003, 5.1.2.5, 5.2.2.3 and 5.3.1.6 of ISO 5167-3:2003 and 5.2.4 of ISO 5167-4:2003 respectively, can be adopted or alternatively the smaller actual values can be computed by the user. (The maximum value for $\delta D/D$ will not exceed 0,4 % whereas the maximum value for $\delta d/d$ will not exceed 0,1 %.)

8.2.2.5 The values of $\delta \Delta p/\Delta p$ and $\delta \rho_1/\rho_1$ shall be determined by the user because the applicable part of ISO 5167 does not specify in detail the method of measurement of the quantities Δp and ρ_1 . The uncertainties in the measurement of both quantities may include components stated by manufacturers as a percentage of full scale. Calculation of percentage uncertainty below full scale shall reflect this increased percentage uncertainty.

8.2.2.6 In order to give an overall uncertainty of q_m providing a level of confidence of approximately 95 %, the user-determined uncertainties shall also be obtained to provide a level of confidence of approximately 95 %.

Annex A (informative)

Iterative computations

An iterative computation procedure is required when a problem cannot be solved by direct calculation methods (see 5.3).

Taking the case for orifice plates for instance, iterative computations are always required to calculate

- the flowrate q_m at given values of μ_1 , ρ_1 , D , Δp and d ,
- the orifice diameter d and β at given values of μ_1 , ρ_1 , D , Δp and q_m ,
- the differential pressure Δp at given values of μ_1 , ρ_1 , D , d and q_m , and
- the diameters D and d at given values of μ_1 , ρ_1 , β , Δp , and q_m .

The principle is to regroup in one member all known values of the basic flowrate Equation (3):

$$q_m = C\varepsilon \frac{\pi}{4} d^2 \left(1 - \beta^4\right)^{-0,5} (2\Delta p \rho_1)^{0,5}$$

and the unknown values in the other member.

The known member is then the “invariant” (denoted “ A_n ” in Table A.1) of the problem.

Then a first guess X_1 is introduced into the unknown member and results in a difference δ_1 between the two members. Iterative computation enables a second guess X_2 to be substituted to obtain δ_2 .

Then X_1 , X_2 , δ_1 and δ_2 are entered into a linear algorithm which computes $X_3 \dots X_n$ and $\delta_3 \dots \delta_n$ until $|\delta_n|$ is smaller than a given value, or until two successive values of X or of δ are seen to be “equal” for a given precision.

An example of a linear algorithm with rapid convergence is

$$X_n = X_{n-1} - \delta_{n-1} \frac{X_{n-1} - X_{n-2}}{\delta_{n-1} - \delta_{n-2}}$$

If the computations are carried out using a programmable numeric calculator, the use of a linear algorithm reduces only slightly the resulting calculations by successive substitutions in the case of computations found in applications relative to this part of ISO 5167.

Note that the values of d , D and β to be introduced in the calculations are those prevailing under the “working conditions” (see 5.3).

For orifice plates, if the plate and the metering tube are made of different materials, it is possible that the variation in β due to the working temperature is not negligible.

Examples of full schemes for iterative computations are given in Table A.1.

Table A.1 — Schemes for iterative computation

Problem	$q =$	$d =$	$\Delta p =$	$D =$
At given values of	$\mu_1, \rho_1, D, d, \Delta p$	$\mu_1, \rho_1, D, q_m, \Delta p$	μ_1, ρ_1, D, d, q_m	$\mu_1, \rho_1, \beta, q_m, \Delta p$
Please find	q_m and q_V	d and β	Δp	D and d
Invariant "A _n "	$A_1 = \frac{\varepsilon d^2 \sqrt{2\Delta p \rho_1}}{\mu_1 D \sqrt{1-\beta^4}}$	$A_2 = \frac{\mu_1 Re(D)}{D \sqrt{2\Delta p \rho_1}}$	$A_3 = \frac{8(1-\beta^4)}{\rho_1} \left(\frac{q_m}{C \pi d^2} \right)^2$	$A_4 = \frac{4\varepsilon \beta^2 q_m \sqrt{2\Delta p \rho_1}}{\pi \mu_1^2 \sqrt{1-\beta^4}}$
Iteration equation	$\frac{Re_D}{C} = A_1$	$\frac{C\varepsilon \beta^2}{\sqrt{1-\beta^4}} = A_2$	$\frac{\Delta p}{\varepsilon - 2} = A_3$	$\frac{Re_D^2}{C} = A_4$
Variable in linear algorithm	$X_1 = Re_D = CA_1$	$X_2 = \frac{\beta^2}{\sqrt{1-\beta^4}} = \frac{A_2}{C\varepsilon}$	$X_3 = \Delta p = \varepsilon^{-2} A_3$	$X_4 = Re_D = \sqrt{CA_4}$
Precision criterion (where n is chosen by the user)	$\left \frac{A_1 - X_1}{A_1} \right < 1 \times 10^{-n}$	$\left \frac{A_2 - X_2 C\varepsilon}{A_2} \right < 1 \times 10^{-n}$	$\left \frac{A_3 - \frac{X_3}{\varepsilon - 2}}{A_3} \right < 1 \times 10^{-n}$	$\left \frac{A_4 - \frac{X_4^2}{C}}{A_4} \right < 1 \times 10^{-n}$
First guess	$C = C_\infty$	$C = 0,606$ (orifice plate), $C = 1$ (other primary devices) $\varepsilon = 0,97$ (or 1)	$\varepsilon = 1$	$C = C_\infty$ $D = \infty$ (if flange tappings)
Results	$q_m = \frac{\pi}{4} \mu_1 D X_1$ $q_V = \frac{q_m}{\rho_1}$	$d = D \left(\frac{X_2}{1 + X_2} \right)^{0,25}$ $\beta = \frac{d}{D}$	$\Delta p = X_3$ If the fluid is a liquid, Δp is obtained in first loop	$D = \frac{4q_m}{\pi \mu_1 X_4}$ $d = \beta D$

Annex B
(informative)

Examples of values of the pipe wall uniform equivalent roughness, k

Table B.1 — Values of k

Values in millimetres

Material	Condition	k	Ra
Brass, copper, aluminium, plastics, glass	smooth, without sediment	< 0,03	< 0,01
Steel	new, stainless	< 0,03	< 0,01
	new, seamless cold drawn	< 0,03	< 0,01
	new, seamless hot drawn	$\leq 0,10$	$\leq 0,03$
	new, seamless rolled		
	new, welded longitudinally	0,10	0,03
	new, welded spirally		
	slightly rusted	0,10 to 0,20	0,03 to 0,06
	rusty	0,20 to 0,30	0,06 to 0,10
	encrusted	0,50 to 2	0,15 to 0,6
	with heavy encrustation	> 2	> 0,6
	bituminized, new	0,03 to 0,05	0,01 to 0,015
	bituminized, normal	0,10 to 0,20	0,03 to 0,06
	galvanized	0,13	0,04
Cast iron	new	0,25	0,08
	rusty	1,0 to 1,5	0,3 to 0,5
	encrusted	> 1,5	> 0,5
	bituminized, new	0,03 to 0,05	0,01 to 0,015
Asbestos cement	coated and not coated, new	< 0,03	< 0,01
	not coated, normal	0,05	0,015
NOTE	In this case, Ra has been calculated on the basis that $Ra \approx \frac{k}{\pi}$.		

Annex C (informative)

Flow conditioners and flow straighteners

C.1 General

Flow conditioners can be classified as either true flow conditioners or flow straighteners. In ISO 5167 (all parts), other than in this annex, the term “flow conditioner” is used to describe both true flow conditioners and flow straighteners.

Inclusion in this annex does not imply that a flow conditioner or flow straightener has passed the compliance test in 7.4.1 with any particular primary device at any particular location. Devices that have been shown to have passed the compliance test in 7.4.1 with any particular primary device are shown in the appropriate parts of ISO 5167.

It is not intended that the descriptions of flow straighteners and flow conditioners given here should limit the use of other designs which have been tested and proved to provide sufficiently small shifts in discharge coefficient when compared with discharge coefficients obtained in a long straight pipe.

Suitable products available commercially are given as examples of flow conditioners or flow straighteners in this annex (see C.2.2 and C.3.2). This information is given for the convenience of users of this part of ISO 5167 and does not constitute an endorsement by ISO of these products.

C.2 Flow straighteners

C.2.1 General description

A flow straightener is a device which removes or significantly reduces swirl but may not simultaneously produce the flow conditions specified in 7.3.3.

Examples of flow straighteners are the tube bundle flow straightener, the AMCA straightener and the Étoile straightener.

C.2.2 Examples

C.2.2.1 The tube bundle flow straightener

The tube bundle flow straightener consists of a bundle of parallel and tangential tubes fixed together and held rigidly in the pipe (see Figure C.1). It is important to ensure that the various tubes are parallel to each other and to the pipe axis since, if this requirement is not met, the straightener itself might introduce swirl to the flow.

There should be at least 19 tubes. Their length should be greater than or equal to $10d_t$, where the diameter of the tube d_t is shown on Figure C.1. The tubes are joined together and the bundle rests against the pipe.

A special case [the 19-tube bundle flow straightener (1998)] is described in more detail in 6.3.2 of ISO 5167-2:2003.

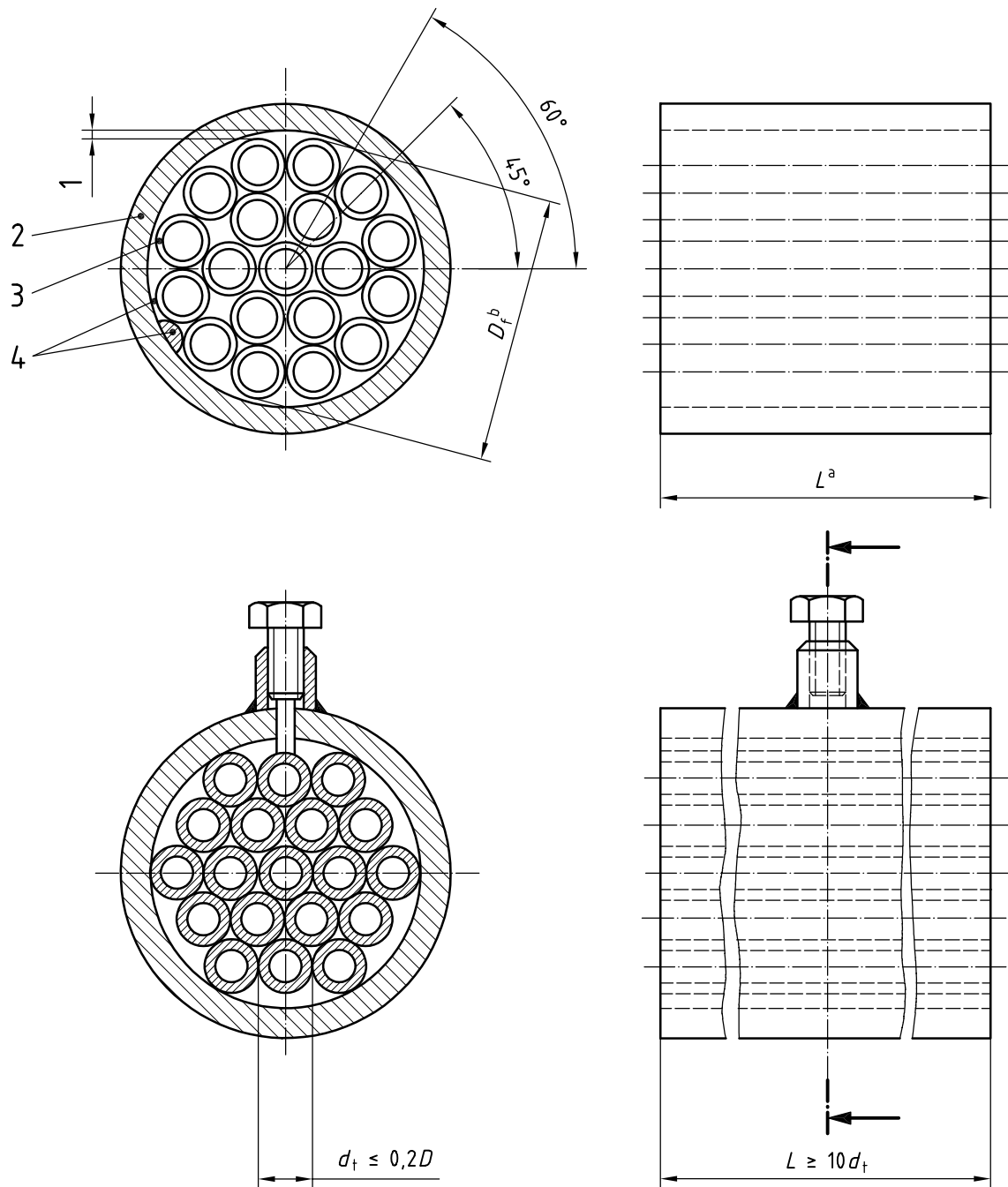

Key

- 1 minimized gap
- 2 pipe wall
- 3 tube wall thickness (which is less than $0,025D$)
- 4 centring spacer options – typically 4 places

^a The length, L , of the tubes shall be between $2D$ and $3D$, preferably as close to $2D$ as possible.

^b D_f = flow straightener outside diameter, and $0,95D \leq D_f \leq D$.

Figure C.1 — Examples of the tube bundle flow straightener

The pressure loss coefficient, K , for the tube bundle flow straightener depends on the number of the tubes and their wall thickness, but for the 19-tube bundle flow straightener (1998) it is approximately equal to 0,75, where K is given by the following equation:

$$K = \frac{\Delta p_c}{\frac{1}{2} \rho V^2}$$

where

Δp_c is the pressure loss across the flow straightener or flow conditioner;

V is the mean axial velocity of the fluid in the pipe.

An alternative design of tube bundle flow straightener has the tubes attached at their outer rim to a flange which very slightly protrudes into the pipe.

C.2.2.2 The AMCA straightener

The AMCA straightener consists of a honeycomb with square meshes, the dimensions of which are shown in Figure C.2. The vanes should be as thin as possible but should provide adequate strength.

The pressure loss coefficient, K , for the AMCA straightener is approximately equal to 0,25.

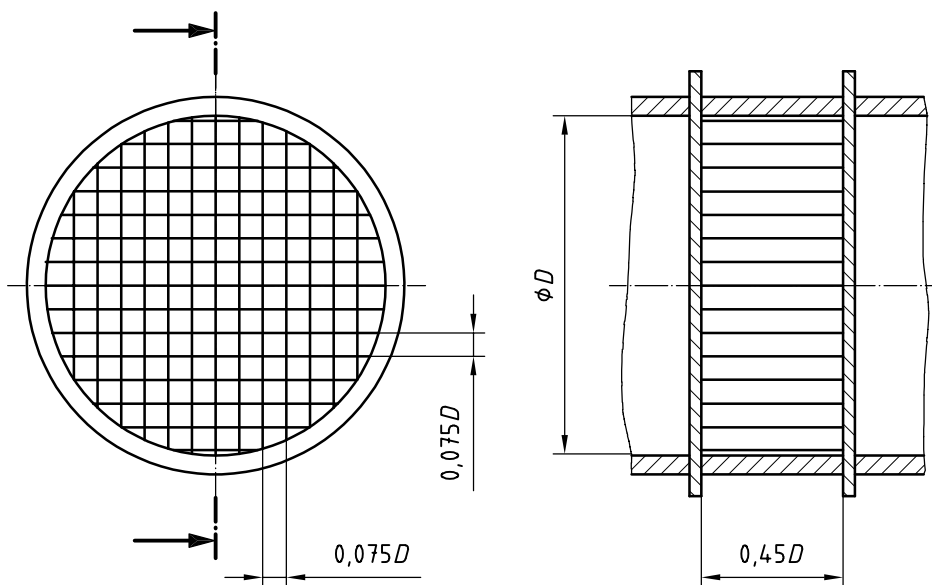

Figure C.2 — The AMCA straightener

C.2.2.3 The Étoile straightener

The Étoile straightener consists of eight radial vanes at equal angular spacing with a length equal to twice the diameter of the pipe (see Figure C.3). The vanes should be as thin as possible but should provide adequate strength.

The pressure loss coefficient, K , for the Étoile straightener is approximately equal to 0,25.

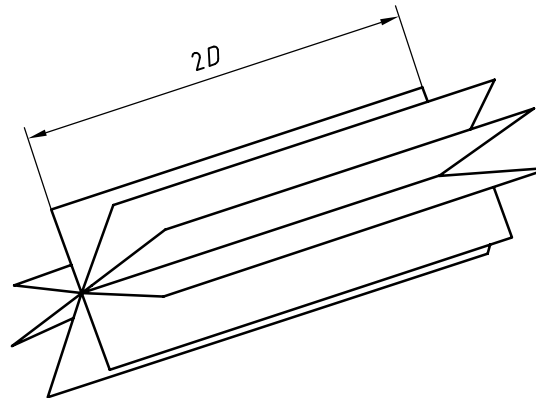

Figure C.3 — The Étoile straightener

C.3 Flow conditioners

C.3.1 General description

A flow conditioner is a device which, in addition to meeting the requirements of removing or significantly reducing swirl, is designed to redistribute the velocity profile to produce conditions close to those of 7.3.3.

Many flow conditioners either are or include a perforated plate. Several such devices are now described in technical literature and they are in general easier to manufacture, install and accommodate than the tube bundle flow straightener. They have the advantage that their thickness is typically around $D/8$ as compared to a length of at least $2D$ for the tube bundle. Moreover, since they can be drilled from the solid rather than fabricated, a more robust device is produced offering repeatable performance.

In these devices swirl is reduced and the profile simultaneously redistributed by a suitable arrangement of hole and plate depth. A number of different designs are available as indicated in Annex B of ISO 5167-2:2003. The geometry of the plate is critical in determining the performance, effectiveness and pressure loss across the plate.

The Gallagher, K-Lab NOVA, NEL (Spearman), Sprengle, and Zanker flow conditioners are examples of flow conditioners.

C.3.2 Examples

C.3.2.1 The Gallagher flow conditioner

The Gallagher flow conditioner is covered by an existing patent. It consists of an anti-swirl device, a settling chamber and lastly a profile device as shown in Figures C.4 and C.5.

The pressure loss coefficient, K , for the Gallagher flow conditioner depends on the manufacturing specification of the conditioner; it is approximately equal to 2.

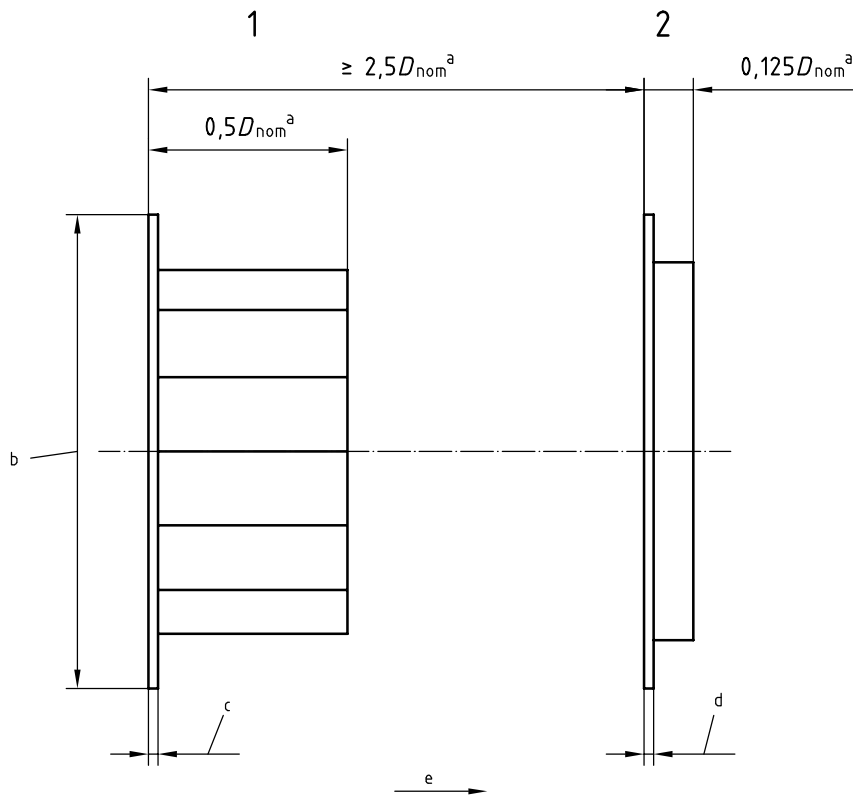

Key

- 1 anti-swirl device
- 2 profile device

- a D_{nom} = nominal pipe diameter
- b Length equal to diameter of raised face
- c 3,2 mm for D_{nom} = 50 mm to 75 mm tube style
 6,4 mm for D_{nom} = 100 mm to 450 mm tube style
 12,7 mm for D_{nom} = 500 mm to 600 mm tube style
 12,7 mm for D_{nom} = 50 mm to 300 mm vane style
 17,1 mm for D_{nom} = 350 mm to 600 mm vane style
- d 3,2 mm for D_{nom} = 50 mm to 75 mm
 6,4 mm for D_{nom} = 100 mm to 450 mm
 12,7 mm for D_{nom} = 500 mm to 600 mm
- e Direction of flow

Figure C.4 — Typical arrangement of a Gallagher flow conditioner

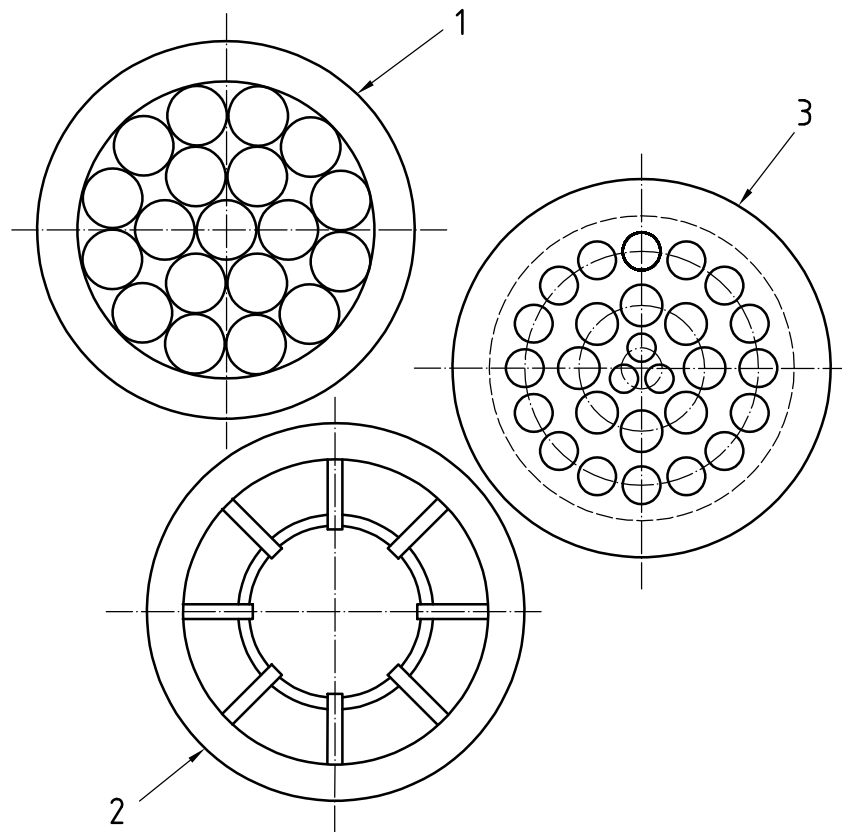

Key

- 1 anti-swirl device – tube style option: 19-tube uniform concentric bundle (it may be pin-mounted)
- 2 anti-swirl device – vane style option: 8 vanes of length $0,125D$ to $0,25D$, concentric with the pipe (the device may be placed at the entrance to the meter run)
- 3 profile device: 3-8-16 pattern (see Note)

NOTE The 3-8-16 pattern for a profile device is:

- 3 holes on pitch circle diameter $0,15D$ to $0,155D$; their diameter is such that the sum of their areas is 3 % to 5 % of the pipe area;
- 8 holes on pitch circle diameter $0,44D$ to $0,48D$; their diameter is such that the sum of their areas is 19 % to 21 % of the pipe area;
- 16 holes on pitch circle diameter $0,81D$ to $0,85D$; their diameter is such that the sum of their areas is 25 % to 29 % of the pipe area.

Figure C.5 — Typical components (face views) of a Gallagher flow conditioner

C.3.2.2 NOVA's design of K-Lab perforated plate flow conditioner

NOVA's design of K-Lab perforated plate, known as the K-Lab NOVA flow conditioner, is covered by an existing patent. It consists of a plate with 25 bored holes arranged in a symmetrical circular pattern as shown in Figure C.6. The perforated plate thickness, t_c , is such that $0,125D \leq t_c \leq 0,15D$. The flange thickness depends on the application; the outer diameter and flange face surface depend on the flange type and the application. The dimensions of the holes are a function of the pipe inside diameter, D , and depend on the pipe Reynolds number.

Provided that $Re_D \geq 8 \times 10^5$ there are

- a central hole of diameter $0,186\ 29D \pm 0,000\ 77D$;
- a ring of 8 holes of diameter $0,163D \pm 0,000\ 77D$ on a pitch circle diameter of $0,5D \pm 0,5\ \text{mm}$, and
- a ring of 16 holes of diameter $0,120\ 3D \pm 0,000\ 77D$ on a pitch circle diameter of $0,85D \pm 0,5\ \text{mm}$.

Provided that $8 \times 10^5 > Re_D \geq 10^5$ there are

- a central hole of diameter $0,226\ 64D \pm 0,000\ 77D$;
- a ring of 8 holes of diameter $0,163\ 09D \pm 0,000\ 77D$ on a pitch circle diameter of $0,5D \pm 0,5\ \text{mm}$, and
- a ring of 16 holes of diameter $0,124\ 22D \pm 0,000\ 77D$ on a pitch circle diameter of $0,85D \pm 0,5\ \text{mm}$.

The pressure loss coefficient, K , for the K-Lab NOVA flow conditioner is approximately equal to 2.

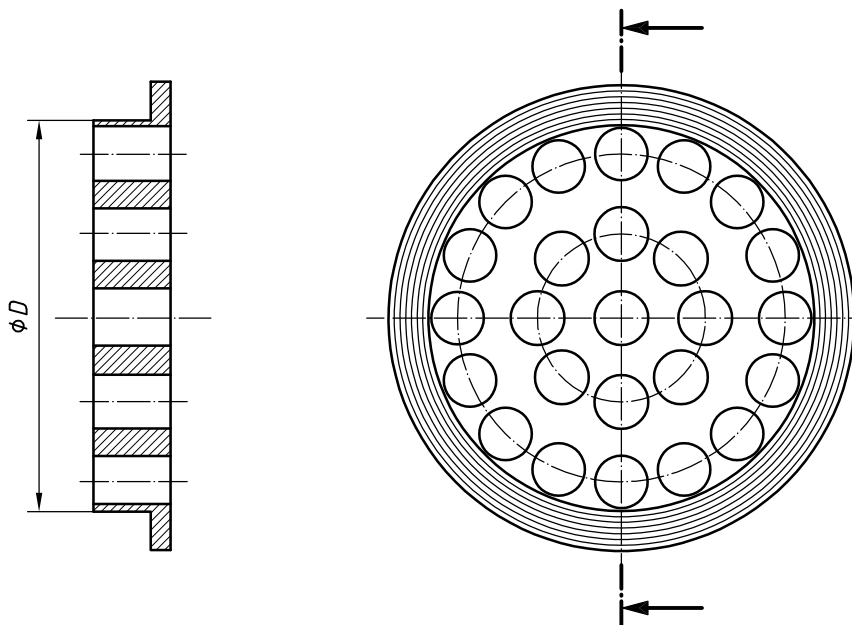

Figure C.6 — The K-Lab NOVA flow conditioner

C.3.2.3 The NEL (Spearman) flow conditioner

The NEL (Spearman) flow conditioner is shown in Figure C.7. The dimensions of the holes are a function of the pipe inside diameter, D . There are:

- a) a ring of 4 holes (d_1) of diameter $0,10D$ on a pitch circle diameter of $0,18D$;
- b) a ring of 8 holes (d_2) of diameter $0,16D$ on a pitch circle diameter of $0,48D$, and
- c) a ring of 16 holes (d_3) of diameter $0,12D$ on a pitch circle diameter of $0,86D$.

The perforated plate thickness is $0,12D$.

The pressure loss coefficient, K , for the NEL (Spearman) flow conditioner is approximately equal to 3,2.

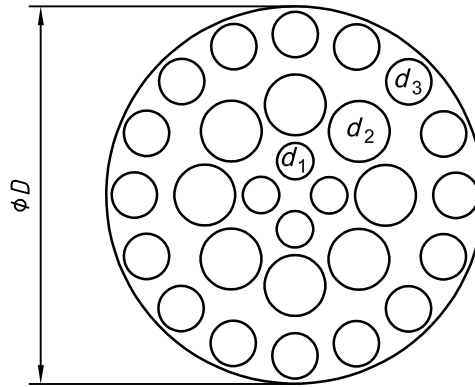

Figure C.7 — NEL (Spearman) flow conditioner

C.3.2.4 Sprengle conditioner

The Sprengle conditioner consists of three perforated plates in series with a length equal to $D \pm 0,1D$ between successive plates. The holes should preferably be chamfered at 45° on the upstream side to reduce the pressure loss, and the total area of the holes in each plate should be greater than 40 % of the cross-sectional area of the pipe. The ratio of plate thickness to hole diameter should be at least 1 and the diameter of the holes should be less than or equal to $0,05D$ (see Figure C.8).

The three plates are held together by bars or studs, which are located around the periphery of the pipe bore, and which should be of as small a diameter as possible but should provide the required strength.

The pressure loss coefficient, K , for the Sprengle conditioner is approximately equal to 11 if there is an inlet bevel or 14 if there is no inlet bevel.

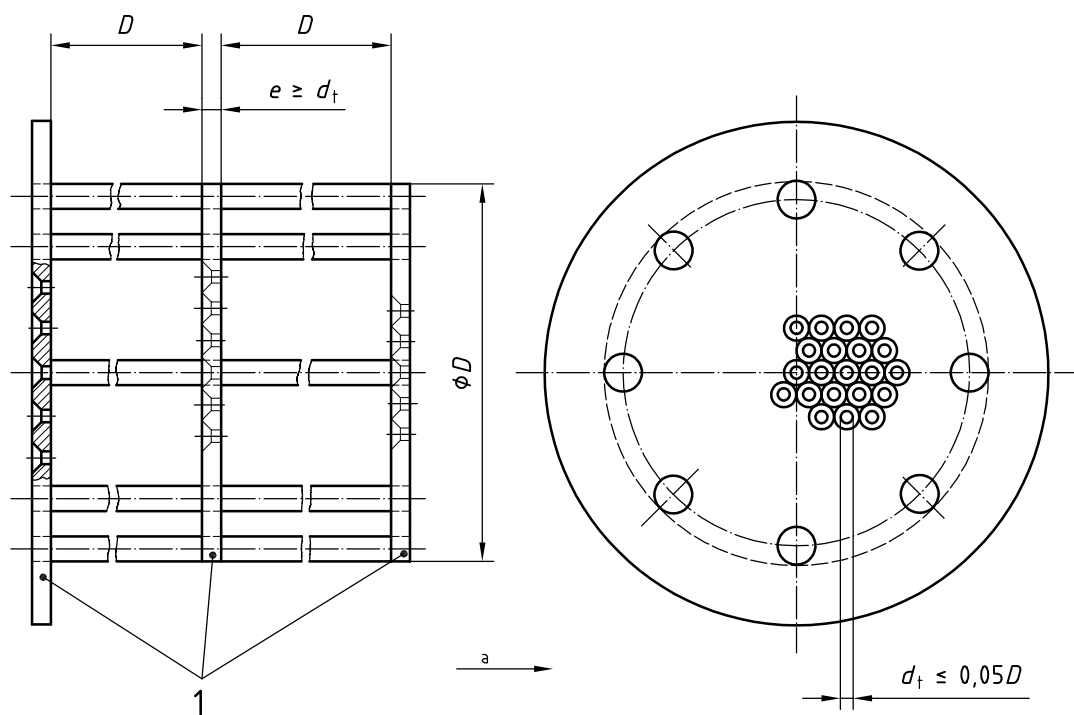

Key

1 perforated plates

a Direction of flow

Figure C.8 — Sprengle straightener

C.3.2.5 Zanker flow conditioner

The Zanker flow conditioner consists of a perforated plate with holes of certain specified sizes followed by a number of channels (one for each hole) formed by the intersection of a number of plates (see Figure C.9). The various plates should be as thin as possible but should provide adequate strength.

The pressure loss coefficient, K , for the Zanker flow conditioner is approximately equal to 5.

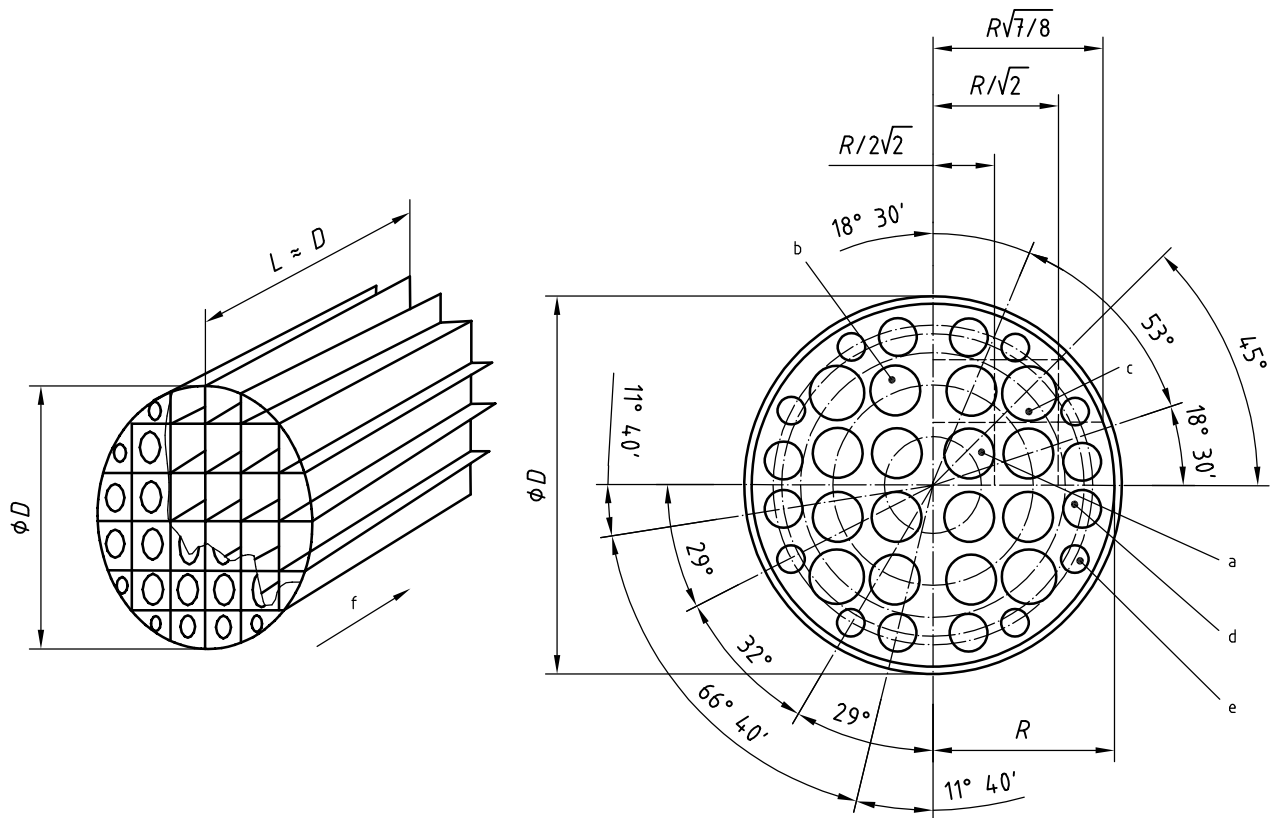

- a Hole diameter $0,141D$, pcd $0,25D$, 4 holes
- b Hole diameter $0,139D$, pcd $0,56D$, 8 holes
- c Hole diameter $0,1365D$, pcd $0,75D$, 4 holes
- d Hole diameter $0,11D$, pcd $0,85D$, 8 holes
- e Hole diameter $0,077D$, pcd $0,90D$, 4 holes
- f Direction of flow

Figure C.9 — Zanker flow conditioner

C.3.2.6 Zanker flow conditioner plate

The Zanker flow conditioner plate described here is a development of the Zanker conditioner described in C.3.2.5. The Zanker flow conditioner plate has the same distribution of holes in a plate but does not have the egg-box honeycomb attached to the plate; instead the plate thickness has been increased to $D/8$.

The Zanker flow conditioner plate is illustrated in Figure C.10 and consists of 32 bored holes arranged in a symmetrical circular pattern. The dimensions of the holes are a function of the pipe inside diameter D . There are

- a) a ring of 4 central holes of diameter $0,141D \pm 0,001D$ on a pitch circle diameter (pcd) of $0,25D \pm 0,0025D$;
- b) a ring of 8 holes of diameter $0,139D \pm 0,001D$ on a pitch circle diameter (pcd) of $0,56D \pm 0,0056D$;
- c) a ring of 4 holes of diameter $0,1365D \pm 0,001D$ on a pitch circle diameter (pcd) of $0,75D \pm 0,0075D$;
- d) a ring of 8 holes of diameter $0,110D \pm 0,001D$ on a pitch circle diameter (pcd) of $0,85D \pm 0,0085D$;
- e) a ring of 8 holes of diameter $0,077D \pm 0,001D$ on a pitch circle diameter (pcd) of $0,90D \pm 0,009D$.

The tolerance on the diameter of each hole is $\pm 0,1$ mm for $D < 100$ mm.

The perforated plate thickness, t_c , is such that $0,12D \leq t_c \leq 0,15D$. The flange thickness depends on the application; the outer diameter and flange face surfaces depend on the flange type and application.

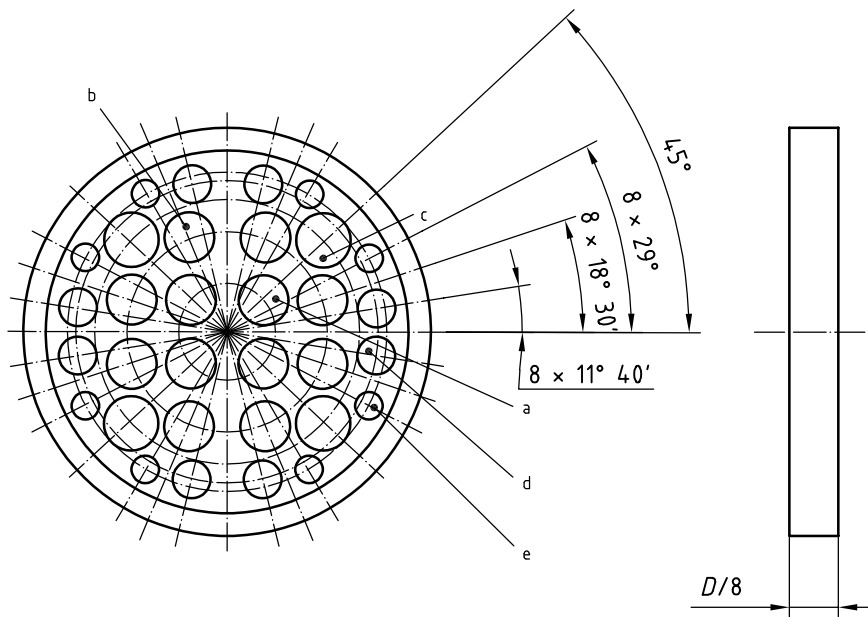

- a) Hole diameter $0,141D$, pcd $0,25D$, 4 holes
- b) Hole diameter $0,139D$, pcd $0,56D$, 8 holes
- c) Hole diameter $0,1365D$, pcd $0,75D$, 4 holes
- d) Hole diameter $0,11D$, pcd $0,85D$, 8 holes
- e) Hole diameter $0,077D$, pcd $0,90D$, 8 holes

Figure C.10 — Zanker flow conditioner plate

The pressure loss coefficient, K , for the Zanker flow conditioner plate is approximately equal to 3.

Bibliography

- [1] NIAZI, A. and THALAYASINGAM, S. Temperature changes across orifice meters. In *Proc. of 19th North Sea Flow Measurement Workshop*, Norway, Paper 13, October 2001
- [2] STUDZINSKI, W. and BOWEN, J. White Paper on *Dynamic Effects on Orifice Measurement*, Washington D.C., American Petroleum Institute, 1997
- [3] SCHLICHTING, H. *Boundary layer theory*. New York, McGraw-Hill, 1960
- [4] STUDZINSKI, W., KARNIK, U., LANASA, P., MORROW, T., GOODSON, D., HUSAIN, Z. and GALLAGHER, J. White Paper on *Orifice Meter Installation Configurations with and without Flow Conditioners*, Washington D.C., American Petroleum Institute, 1997
- [5] SHEN, J.J.S. *Characterization of Swirling Flow and its Effects on Orifice Metering*. SPE 22865. Richardson, Texas: Society of Petroleum Engineers, 1991
- [6] READER-HARRIS, M.J. Pipe roughness and Reynolds number limits for the orifice plate discharge coefficient equation. In *Proc. of 2nd Int. Symp. on Fluid Flow Measurement*, Calgary, Canada, Arlington, Virginia: American Gas Association, June 1990, pp. 29-43
- [7] READER-HARRIS, M.J., SATTARY, J.A. and SPEARMAN, E. P. *The orifice plate discharge coefficient equation*. Progress Report No PR14: EUEC/17 (EEC005). East Kilbride, Glasgow: National Engineering Laboratory Executive Agency, May 1992
- [8] ISO/TR 3313:1998, *Measurement of fluid flow in closed conduits — Guidelines on the effects of flow pulsations on flow-measurement instruments*
- [9] ISO 4288:1996, *Geometrical Product Specification (GPS) — Surface texture: Profile method — Rules and procedures for the assessment of surface texture*
- [10] ISO/TR 5168:1998, *Measurement of fluid flow — Evaluation of uncertainties*
- [11] ISO/TR 9464:1998, *Guidelines for the use of ISO 5167-1:1991*

(Continued from second cover)

<i>International Standard</i>	<i>Corresponding Indian Standard</i>	<i>Degree of Equivalence</i>
ISO 5167-4 : 2003 Measurement of fluid flow by means of pressure differential devices inserted in circular cross-section conduits running full — Part 4 : Venturi tubes	IS 14615 (Part 4) : 2018 Measurement of fluid flow by means of pressure differential devices inserted in circular cross-section conduits running full — Part 4 : Venturi tubes	Identical

The technical committee has reviewed the provisions of the following International Standard referred in this adopted standard and has decided that they are acceptable for use in conjunction with this standard:

<i>International Standard</i>	<i>Title</i>
ISO 4006 : 1991	Measurement of fluid flow in closed conduits — Vocabulary and Symbols

For the purpose of deciding whether a particular requirement of this standard is complied with, the final value, observed or calculated, expressing the result of a test or analysis, shall be rounded off in accordance with IS 2 : 1960 'Rules for rounding off numerical values (revised)'. The number of significant places retained in the rounded off value should be same as that of the specified value in this standard.

Bureau of Indian Standards

BIS is a statutory institution established under the *Bureau of Indian Standards Act, 1986* to promote harmonious development of the activities of standardization, marking and quality certification of goods and attending to connected matters in the country.

Copyright

BIS has the copyright of all its publications. No part of these publications may be reproduced in any form without the prior permission in writing of BIS. This does not preclude the free use, in the course of implementing the standard, of necessary details, such as symbols and sizes, type or grade designations. Enquiries relating to copyright be addressed to the Director (Publications), BIS.

Review of Indian Standards

Amendments are issued to standards as the need arises on the basis of comments. Standards are also reviewed periodically; a standard along with amendments is reaffirmed when such review indicates that no changes are needed; if the review indicates that changes are needed, it is taken up for revision. Users of Indian Standards should ascertain that they are in possession of the latest amendments or edition by referring to the latest issue of 'BIS Catalogue' and 'Standards : Monthly Additions'.

This Indian Standard has been developed from Doc No.: WRD 01 (0664).

Amendments Issued Since Publication

Amend No.	Date of Issue	Text Affected

BUREAU OF INDIAN STANDARDS

Headquarters:

Manak Bhavan, 9 Bahadur Shah Zafar Marg, New Delhi 110002
Telephones : 2323 0131, 2323 3375, 2323 9402 Website: www.bis.org.in

Regional Offices:

	Telephones
Central : Manak Bhavan, 9 Bahadur Shah Zafar Marg NEW DELHI 110002	{ 2323 7617 2323 3841
Eastern : 1/14 C.I.T. Scheme VII M, V. I. P. Road, Kankurgachi KOLKATA 700054	{ 2337 8499, 2337 8561 2337 8626, 2337 9120
Northern : Plot No. 4-A, Sector 27-B, Madhya Marg, CHANDIGARH 160019	{ 26 50206 265 0290
Southern : C.I.T. Campus, IV Cross Road, CHENNAI 600113	{ 2254 1216, 2254 1442 2254 2519, 2254 2315
Western : Manakalaya, E9 MIDC, Marol, Andheri (East) MUMBAI 400093	{ 2832 9295, 2832 7858 2832 7891, 2832 7892

Branches: AHMEDABAD. BENGALURU. BHOPAL. BHUBANESHWAR. COIMBATORE. DEHRADUN. DURGAPUR. FARIDABAD. GHAZIABAD. GUWAHATI. HYDERABAD. JAIPUR. JAMMU. JAMSHEDPUR. KOCHI. LUCKNOW. NAGPUR. PARWANOO. PATNA. PUNE. RAIPUR. RAJKOT. VISAKHAPATNAM.